

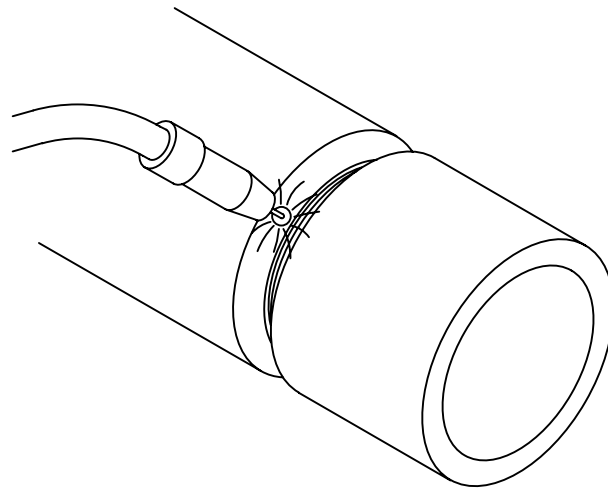

Pipe Welding



Handbook



TABLE OF CONTENTS

SECTION 1 – SAFETY PRECAUTIONS - READ BEFORE USING	1
1-1. Symbol Usage	1
1-2. Arc Welding Hazards	1
1-3. Additional Symbols For Installation, Operation, And Maintenance	3
1-4. California Proposition 65 Warnings	4
1-5. Principal Safety Standards	4
1-6. EMF Information	4
SECTION 2 – CONSIGNES DE SÉCURITÉ – LIRE AVANT UTILISATION	5
2-1. Symboles utilisés	5
2-2. Dangers relatifs au soudage à l'arc	5
2-3. Dangers supplémentaires en relation avec l'installation, le fonctionnement et la maintenance	7
2-4. Proposition californienne 65 Avertissements	8
2-5. Principales normes de sécurité	9
2-6. Informations relatives aux CEM	9
SECTION 3 – GMAW FUNDAMENTALS	11
3-1. Basic Information	11
3-2. Welding Positions	15
3-3. GMAW (MIG) / FCAW PipePro System	16
3-4. Typical PipeWorx Connection Diagram For MIG (GMAW) Equipment With Feeder On Power Source	17
3-5. Typical PipeWorx Connection Diagram For MIG (GMAW) Equipment With Feeder On Cart	18
3-6. Process Variable Definitions	19
3-7. Joint Preparation And Typical Recommendations For 1G, 5G, 6G, And 6GR	20
3-8. RMD Open Root Joint Preparation	21
3-9. 5G Welding Technique Recommendations	23
3-10. 1G Welding Technique Recommendations	27
3-11. Welding Passes And Appropriate Process With Parameter Ranges	30
3-12. Troubleshooting Guide	38

SECTION 1 – SAFETY PRECAUTIONS - READ BEFORE USING

som_2010-03

 Protect yourself and others from injury — read and follow these precautions.

1-1. Symbol Usage

 **DANGER!** – Indicates a hazardous situation which, if not avoided, will result in death or serious injury. The possible hazards are shown in the adjoining symbols or explained in the text.

 Indicates a hazardous situation which, if not avoided, could result in death or serious injury. The possible hazards are shown in the adjoining symbols or explained in the text.

NOTICE – Indicates statements not related to personal injury.

 Indicates special instructions.



This group of symbols means Warning! Watch Out! ELECTRIC SHOCK, MOVING PARTS, and HOT PARTS hazards. Consult symbols and related instructions below for necessary actions to avoid the hazards.

1-2. Arc Welding Hazards

 The symbols shown below are used throughout this manual to call attention to and identify possible hazards. When you see the symbol, watch out, and follow the related instructions to avoid the hazard. The safety information given below is only a summary of the more complete safety information found in the Safety Standards listed in Section 1-5. Read and follow all Safety Standards.

 Only qualified persons should install, operate, maintain, and repair this unit.

 During operation, keep everybody, especially children, away.



ELECTRIC SHOCK can kill.

Touching live electrical parts can cause fatal shocks or severe burns. The electrode and work circuit is electrically live whenever the output is on. The input power circuit and machine internal circuits are also live when power is on. In semiautomatic or automatic wire welding, the wire, wire reel, drive roll housing, and all metal parts touching the welding wire are electrically live. Incorrectly installed or improperly grounded equipment is a hazard.

- Do not touch live electrical parts.
- Wear dry, hole-free insulating gloves and body protection.
- Insulate yourself from work and ground using dry insulating mats or covers big enough to prevent any physical contact with the work or ground.
- Do not use AC output in damp areas, if movement is confined, or if there is a danger of falling.
- Use AC output ONLY if required for the welding process.
- If AC output is required, use remote output control if present on unit.
- Additional safety precautions are required when any of the following electrically hazardous conditions are present: in damp locations or while wearing wet clothing; on metal structures such as floors, gratings, or scaffolds; when in cramped positions such as sitting, kneeling, or lying; or when there is a high risk of unavoidable or accidental contact with the workpiece or ground. For these conditions, use the following equipment in order presented: 1) a semiautomatic DC constant voltage (wire) welder, 2) a DC manual (stick) welder, or 3) an AC welder with reduced open-circuit voltage. In most situations, use of a DC, constant voltage wire welder is recommended. And, do not work alone!
- Disconnect input power or stop engine before installing or servicing this equipment. Lockout/tagout input power according to OSHA 29 CFR 1910.147 (see Safety Standards).

- Properly install and ground this equipment according to its Owner's Manual and national, state, and local codes.
- Always verify the supply ground – check and be sure that input power cord ground wire is properly connected to ground terminal in disconnect box or that cord plug is connected to a properly grounded receptacle outlet.
- When making input connections, attach proper grounding conductor first – double-check connections.
- Keep cords dry, free of oil and grease, and protected from hot metal and sparks.
- Frequently inspect input power cord for damage or bare wiring – replace cord immediately if damaged – bare wiring can kill.
- Turn off all equipment when not in use.
- Do not use worn, damaged, undersized, or poorly spliced cables.
- Do not drape cables over your body.
- If earth grounding of the workpiece is required, ground it directly with a separate cable.
- Do not touch electrode if you are in contact with the work, ground, or another electrode from a different machine.
- Do not touch electrode holders connected to two welding machines at the same time since double open-circuit voltage will be present.
- Use only well-maintained equipment. Repair or replace damaged parts at once. Maintain unit according to manual.
- Wear a safety harness if working above floor level.
- Keep all panels and covers securely in place.
- Clamp work cable with good metal-to-metal contact to workpiece or worktable as near the weld as practical.
- Insulate work clamp when not connected to workpiece to prevent contact with any metal object.
- Do not connect more than one electrode or work cable to any single weld output terminal.

SIGNIFICANT DC VOLTAGE exists in inverter welding power sources AFTER removal of input power.

- Turn Off inverter, disconnect input power, and discharge input capacitors according to instructions in Maintenance Section before touching any parts.



HOT PARTS can burn.

- Do not touch hot parts bare handed.
- Allow cooling period before working on equipment.
- To handle hot parts, use proper tools and/or wear heavy, insulated welding gloves and clothing to prevent burns.



FUMES AND GASES can be hazardous.

Welding produces fumes and gases. Breathing these fumes and gases can be hazardous to your health.

- Keep your head out of the fumes. Do not breathe the fumes.
- If inside, ventilate the area and/or use local forced ventilation at the arc to remove welding fumes and gases.
- If ventilation is poor, wear an approved air-supplied respirator.
- Read and understand the Material Safety Data Sheets (MSDSs) and the manufacturer's instructions for metals, consumables, coatings, cleaners, and degreasers.
- Work in a confined space only if it is well ventilated, or while wearing an air-supplied respirator. Always have a trained watch-person nearby. Welding fumes and gases can displace air and lower the oxygen level causing injury or death. Be sure the breathing air is safe.
- Do not weld in locations near degreasing, cleaning, or spraying operations. The heat and rays of the arc can react with vapors to form highly toxic and irritating gases.
- Do not weld on coated metals, such as galvanized, lead, or cadmium plated steel, unless the coating is removed from the weld area, the area is well ventilated, and while wearing an air-supplied respirator. The coatings and any metals containing these elements can give off toxic fumes if welded.



ARC RAYS can burn eyes and skin.

Arc rays from the welding process produce intense visible and invisible (ultraviolet and infrared) rays that can burn eyes and skin. Sparks fly off from the weld.

- Wear an approved welding helmet fitted with a proper shade of filter lenses to protect your face and eyes from arc rays and sparks when welding or watching (see ANSI Z49.1 and Z87.1 listed in Safety Standards).
- Wear approved safety glasses with side shields under your helmet.
- Use protective screens or barriers to protect others from flash, glare and sparks; warn others not to watch the arc.
- Wear protective clothing made from durable, flame-resistant material (leather, heavy cotton, or wool) and foot protection.



WELDING can cause fire or explosion.

Welding on closed containers, such as tanks, drums, or pipes, can cause them to blow up. Sparks can fly off from the welding arc. The flying sparks, hot workpiece, and hot equipment can cause fires and burns. Accidental contact of electrode to metal objects can cause sparks, explosion, overheating, or fire. Check and be sure the area is safe before doing any welding.

- Remove all flammables within 35 ft (10.7 m) of the welding arc. If this is not possible, tightly cover them with approved covers.
- Do not weld where flying sparks can strike flammable material.
- Protect yourself and others from flying sparks and hot metal.
- Be alert that welding sparks and hot materials from welding can easily go through small cracks and openings to adjacent areas.
- Watch for fire, and keep a fire extinguisher nearby.
- Be aware that welding on a ceiling, floor, bulkhead, or partition can cause fire on the hidden side.
- Do not weld on closed containers such as tanks, drums, or pipes, unless they are properly prepared according to AWS F4.1 (see Safety Standards).
- Do not weld where the atmosphere may contain flammable dust, gas, or liquid vapors (such as gasoline).
- Connect work cable to the work as close to the welding area as practical to prevent welding current from traveling long, possibly unknown paths and causing electric shock, sparks, and fire hazards.
- Do not use welder to thaw frozen pipes.

- Remove stick electrode from holder or cut off welding wire at contact tip when not in use.
- Wear oil-free protective garments such as leather gloves, heavy shirt, cuffless trousers, high shoes, and a cap.
- Remove any combustibles, such as a butane lighter or matches, from your person before doing any welding.
- After completion of work, inspect area to ensure it is free of sparks, glowing embers, and flames.
- Use only correct fuses or circuit breakers. Do not oversize or bypass them.
- Follow requirements in OSHA 1910.252 (a) (2) (iv) and NFPA 51B for hot work and have a fire watcher and extinguisher nearby.

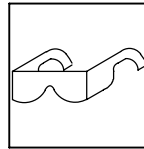

FLYING METAL or DIRT can injure eyes.

- Welding, chipping, wire brushing, and grinding cause sparks and flying metal. As welds cool, they can throw off slag.
- Wear approved safety glasses with side shields even under your welding helmet.



BUILDUP OF GAS can injure or kill.

- Shut off shielding gas supply when not in use.
- Always ventilate confined spaces or use approved air-supplied respirator.

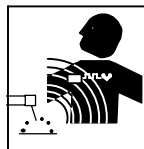

ELECTRIC AND MAGNETIC FIELDS (EMF) can affect Implanted Medical Devices.

- Wearers of Pacemakers and other Implanted Medical Devices should keep away.
- Implanted Medical Device wearers should consult their doctor and the device manufacturer before going near arc welding, spot welding, gouging, plasma arc cutting, or induction heating operations.

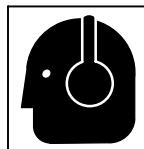

NOISE can damage hearing.

Noise from some processes or equipment can damage hearing.

- Wear approved ear protection if noise level is high.

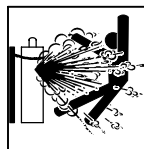

CYLINDERS can explode if damaged.

Shielding gas cylinders contain gas under high pressure. If damaged, a cylinder can explode. Since gas cylinders are normally part of the welding process, be sure to treat them carefully.

- Protect compressed gas cylinders from excessive heat, mechanical shocks, physical damage, slag, open flames, sparks, and arcs.
- Install cylinders in an upright position by securing to a stationary support or cylinder rack to prevent falling or tipping.
- Keep cylinders away from any welding or other electrical circuits.
- Never drape a welding torch over a gas cylinder.
- Never allow a welding electrode to touch any cylinder.
- Never weld on a pressurized cylinder – explosion will result.
- Use only correct shielding gas cylinders, regulators, hoses, and fittings designed for the specific application; maintain them and associated parts in good condition.
- Turn face away from valve outlet when opening cylinder valve.
- Keep protective cap in place over valve except when cylinder is in use or connected for use.
- Use the right equipment, correct procedures, and sufficient number of persons to lift and move cylinders.
- Read and follow instructions on compressed gas cylinders, associated equipment, and Compressed Gas Association (CGA) publication P-1 listed in Safety Standards.

1-3. Additional Symbols For Installation, Operation, And Maintenance



FIRE OR EXPLOSION hazard.

- Do not install or place unit on, over, or near combustible surfaces.
- Do not install unit near flammables.
- Do not overload building wiring – be sure power supply system is properly sized, rated, and protected to handle this unit.



FALLING EQUIPMENT can injure.

- Use lifting eye to lift unit only, NOT running gear, gas cylinders, or any other accessories.
- Use equipment of adequate capacity to lift and support unit.
- If using lift forks to move unit, be sure forks are long enough to extend beyond opposite side of unit.
- Keep equipment (cables and cords) away from moving vehicles when working from an aerial location.
- Follow the guidelines in the Applications Manual for the Revised NIOSH Lifting Equation (Publication No. 94-110) when manually lifting heavy parts or equipment.

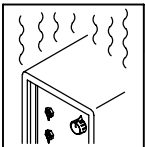

OVERUSE can cause OVERHEATING

- Allow cooling period; follow rated duty cycle.
- Reduce current or reduce duty cycle before starting to weld again.
- Do not block or filter airflow to unit.

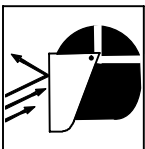

FLYING SPARKS can injure.

- Wear a face shield to protect eyes and face.
- Shape tungsten electrode only on grinder with proper guards in a safe location wearing proper face, hand, and body protection.
- Sparks can cause fires — keep flammables away.

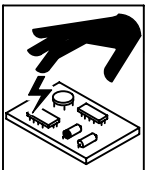

STATIC (ESD) can damage PC boards.

- Put on grounded wrist strap BEFORE handling boards or parts.
- Use proper static-proof bags and boxes to store, move, or ship PC boards.



MOVING PARTS can injure.

- Keep away from moving parts.
- Keep away from pinch points such as drive rolls.



WELDING WIRE can injure.

- Do not press gun trigger until instructed to do so.
- Do not point gun toward any part of the body, other people, or any metal when threading welding wire.



MOVING PARTS can injure.

- Keep away from moving parts such as fans.
- Keep all doors, panels, covers, and guards closed and securely in place.
- Have only qualified persons remove doors, panels, covers, or guards for maintenance and troubleshooting as necessary.
- Reinstall doors, panels, covers, or guards when maintenance is finished and before reconnecting input power.

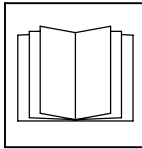

READ INSTRUCTIONS.

- Read and follow all labels and the Owner's Manual carefully before installing, operating, or servicing unit. Read the safety information at the beginning of the manual and in each section.
- Use only genuine replacement parts from the manufacturer.
- Perform maintenance and service according to the Owner's Manuals, industry standards, and national, state, and local codes.

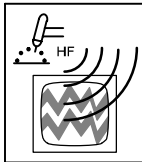

H.F. RADIATION can cause interference.

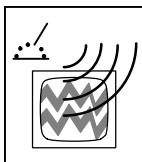

- High-frequency (H.F.) can interfere with radio navigation, safety services, computers, and communications equipment.
- Have only qualified persons familiar with electronic equipment perform this installation.
- The user is responsible for having a qualified electrician promptly correct any interference problem resulting from the installation.
- If notified by the FCC about interference, stop using the equipment at once.
- Have the installation regularly checked and maintained.
- Keep high-frequency source doors and panels tightly shut, keep spark gaps at correct setting, and use grounding and shielding to minimize the possibility of interference.



ARC WELDING can cause interference.

- Electromagnetic energy can interfere with sensitive electronic equipment such as computers and computer-driven equipment such as robots.
- Be sure all equipment in the welding area is electromagnetically compatible.
- To reduce possible interference, keep weld cables as short as possible, close together, and down low, such as on the floor.
- Locate welding operation 100 meters from any sensitive electronic equipment.
- Be sure this welding machine is installed and grounded according to this manual.
- If interference still occurs, the user must take extra measures such as moving the welding machine, using shielded cables, using line filters, or shielding the work area.

1-4. California Proposition 65 Warnings

-  **Welding or cutting equipment produces fumes or gases which contain chemicals known to the State of California to cause birth defects and, in some cases, cancer. (California Health & Safety Code Section 25249.5 et seq.)**
-  **Battery posts, terminals and related accessories contain lead and lead compounds, chemicals known to the State of California to cause cancer and birth defects or other reproductive harm. *Wash hands after handling.***
-  **This product contains chemicals, including lead, known to the state of California to cause cancer, birth defects, or other reproductive harm. *Wash hands after use.***

For Gasoline Engines:

-  **Engine exhaust contains chemicals known to the State of California to cause cancer, birth defects, or other reproductive harm.**

For Diesel Engines:

-  **Diesel engine exhaust and some of its constituents are known to the State of California to cause cancer, birth defects, and other reproductive harm.**

1-5. Principal Safety Standards

Safety in Welding, Cutting, and Allied Processes, ANSI Standard Z49.1, from Global Engineering Documents (phone: 1-877-413-5184, website: www.global.ihs.com).

Safe Practices for the Preparation of Containers and Piping for Welding and Cutting, American Welding Society Standard AWS F4.1, from Global Engineering Documents (phone: 1-877-413-5184, website: www.global.ihs.com).

National Electrical Code, NFPA Standard 70, from National Fire Protection Association, Quincy, MA 02269 (phone: 1-800-344-3555, website: www.nfpa.org and www.sparky.org).

Safe Handling of Compressed Gases in Cylinders, CGA Pamphlet P-1, from Compressed Gas Association, 4221 Walney Road, 5th Floor, Chantilly, VA 20151 (phone: 703-788-2700, website: www.cganet.com).

Safety in Welding, Cutting, and Allied Processes, CSA Standard W117.2, from Canadian Standards Association, Standards Sales, 5060 Spectrum Way, Suite 100, Ontario, Canada L4W 5NS (phone: 800-463-6727, website: www.csa-international.org).

Safe Practice For Occupational And Educational Eye And Face Protection, ANSI Standard Z87.1, from American National Standards Institute,

25 West 43rd Street, New York, NY 10036 (phone: 212-642-4900, website: www.ansi.org).

Standard for Fire Prevention During Welding, Cutting, and Other Hot Work, NFPA Standard 51B, from National Fire Protection Association, Quincy, MA 02269 (phone: 1-800-344-3555, website: www.nfpa.org).

OSHA, Occupational Safety and Health Standards for General Industry, Title 29, Code of Federal Regulations (CFR), Part 1910, Subpart Q, and Part 1926, Subpart J, from U.S. Government Printing Office, Superintendent of Documents, P.O. Box 371954, Pittsburgh, PA 15250-7954 (phone: 1-866-512-1800) (there are 10 OSHA Regional Offices—phone for Region 5, Chicago, is 312-353-2220, website: www.osha.gov).

U.S. Consumer Product Safety Commission (CPSC), 4330 East West Highway, Bethesda, MD 20814 (phone: 301-504-7923, website: www.cpsc.gov).

Applications Manual for the Revised NIOSH Lifting Equation, The National Institute for Occupational Safety and Health (NIOSH), 1600 Clifton Rd, Atlanta, GA 30333 (phone: 1-800-232-4636, website: www.cdc.gov/NIOSH).

1-6. EMF Information

Electric current flowing through any conductor causes localized electric and magnetic fields (EMF). Welding current creates an EMF field around the welding circuit and welding equipment. EMF fields may interfere with some medical implants, e.g. pacemakers. Protective measures for persons wearing medical implants have to be taken. For example, access restrictions for passers—by or individual risk assessment for welders. All welders should use the following procedures in order to minimize exposure to EMF fields from the welding circuit:

1. Keep cables close together by twisting or taping them, or using a cable cover.
2. Do not place your body between welding cables. Arrange cables to one side and away from the operator.
3. Do not coil or drape cables around your body.

4. Keep head and trunk as far away from the equipment in the welding circuit as possible.
5. Connect work clamp to workpiece as close to the weld as possible.
6. Do not work next to, sit or lean on the welding power source.
7. Do not weld whilst carrying the welding power source or wire feeder.

About Implanted Medical Devices:

Implanted Medical Device wearers should consult their doctor and the device manufacturer before performing or going near arc welding, spot welding, gouging, plasma arc cutting, or induction heating operations. If cleared by your doctor, then following the above procedures is recommended.

SECTION 2 – CONSIGNES DE SÉCURITÉ – LIRE AVANT UTILISATION

fre_som_2010-03

⚠ Se protéger et protéger les autres contre le risque de blessure — lire et respecter ces consignes.

2-1. Symboles utilisés

⚠ **DANGER!** – Indique une situation dangereuse qui si on l'évite pas peut donner la mort ou des blessures graves. Les dangers possibles sont montrés par les symboles joints ou sont expliqués dans le texte.

⚠ Indique une situation dangereuse qui si on l'évite pas peut donner la mort ou des blessures graves. Les dangers possibles sont montrés par les symboles joints ou sont expliqués dans le texte.

NOTE – Indique des déclarations pas en relation avec des blessures personnelles.

 Indique des instructions spécifiques.



Ce groupe de symboles veut dire Avertissement! Attention! DANGER DE CHOC ELECTRIQUE, PIECES EN MOUVEMENT, et PIECES CHAUDES. Consulter les symboles et les instructions ci-dessous y afférant pour les actions nécessaires afin d'éviter le danger.

2-2. Dangers relatifs au soudage à l'arc

⚠ Les symboles représentés ci-dessous sont utilisés dans ce manuel pour attirer l'attention et identifier les dangers possibles. En présence de l'un de ces symboles, prendre garde et suivre les instructions afférentes pour éviter tout risque. Les instructions en matière de sécurité indiquées ci-dessous ne constituent qu'un sommaire des instructions de sécurité plus complètes fournies dans les normes de sécurité énumérées dans la Section 2-5. Lire et observer toutes les normes de sécurité.

⚠ Seul un personnel qualifié est autorisé à installer, faire fonctionner, entretenir et réparer cet appareil.

⚠ Pendant le fonctionnement, maintenir à distance toutes les personnes, notamment les enfants de l'appareil.



UNE DÉCHARGE ÉLECTRIQUE peut entraîner la mort.

Le contact d'organes électriques sous tension peut provoquer des accidents mortels ou des brûlures graves. Le circuit de l'électrode et de la pièce est sous tension lorsque le courant est délivré à la sortie. Le circuit d'alimentation et les circuits internes de la machine sont également sous tension lorsque l'alimentation est sur Marche. Dans le mode de soudage avec du fil, le fil, le dérouleur, le bloc de commande du rouleau et toutes les parties métalliques en contact avec le fil sont sous tension électrique. Un équipement installé ou mis à la terre de manière incorrecte ou impropre constitue un danger.

- Ne pas toucher aux pièces électriques sous tension.
- Porter des gants isolants et des vêtements de protection secs et sans trous.
- S'isoler de la pièce à couper et du sol en utilisant des housses ou des tapis assez grands afin d'éviter tout contact physique avec la pièce à couper ou le sol.
- Ne pas se servir de source électrique à courant électrique dans les zones humides, dans les endroits confinés ou là où on risque de tomber.
- Se servir d'une source électrique à courant électrique UNIQUEMENT si le procédé de soudage le demande.
- Si l'utilisation d'une source électrique à courant électrique s'avère nécessaire, se servir de la fonction de télécommande si l'appareil en est équipé.
- D'autres consignes de sécurité sont nécessaires dans les conditions suivantes : risques électriques dans un environnement humide ou si l'on porte des vêtements mouillés ; sur des structures métalliques telles que sols, grilles ou échafaudages ; en position coincée comme assise, à genoux ou couchée ; ou s'il y a un risque élevé de contact inévitable ou accidentel avec la pièce à souder ou le sol. Dans ces conditions, utiliser les équipements suivants, dans l'ordre indiqué : 1) un poste à souder DC à tension constante (à fil), 2) un poste à souder DC manuel (électrode) ou 3) un poste à souder AC à tension à vide réduite. Dans la plupart des situations, l'utilisation d'un poste à souder DC à fil à tension constante est recommandée. En outre, ne pas travailler seul !
- Couper l'alimentation ou arrêter le moteur avant de procéder à l'installation, à la réparation ou à l'entretien de l'appareil. Déverrouiller l'alimentation selon la norme OSHA 29 CFR 1910.147 (voir normes de sécurité).
- Installer le poste correctement et le mettre à la terre convenablement selon les consignes du manuel de l'opérateur et les normes nationales, provinciales et locales.
- Toujours vérifier la terre du cordon d'alimentation. Vérifier et s'assurer que le fil de terre du cordon d'alimentation est bien raccordé à la borne de terre du sectionneur ou que la fiche du cordon est raccordée à une prise correctement mise à la terre.
- En effectuant les raccordements d'entrée, fixer d'abord le conducteur de mise à la terre approprié et contre-vérifier les connexions.
- Les câbles doivent être exempts d'humidité, d'huile et de graisse; protégez-les contre les étincelles et les pièces métalliques chaudes.
- Vérifier fréquemment le cordon d'alimentation afin de s'assurer qu'il n'est pas altéré ou à nu, le remplacer immédiatement s'il l'est. Un fil à nu peut entraîner la mort.
- L'équipement doit être hors tension lorsqu'il n'est pas utilisé.
- Ne pas utiliser des câbles usés, endommagés, de grosseur insuffisante ou mal épissés.
- Ne pas enrouler les câbles autour du corps.
- Si la pièce soudée doit être mise à la terre, le faire directement avec un câble distinct.
- Ne pas toucher l'électrode quand on est en contact avec la pièce, la terre ou une électrode provenant d'une autre machine.
- Ne pas toucher des porte électrodes connectés à deux machines en même temps à cause de la présence d'une tension à vide doublée.
- N'utiliser qu'un matériel en bon état. Réparer ou remplacer sur-le-champ les pièces endommagées. Entretenir l'appareil conformément à ce manuel.
- Porter un harnais de sécurité si l'on doit travailler au-dessus du sol.
- S'assurer que tous les panneaux et couvercles sont correctement en place.
- Fixer le câble de retour de façon à obtenir un bon contact métal-métal avec la pièce à souder ou la table de travail, le plus près possible de la soudure.
- Isoler la pince de masse quand pas mis à la pièce pour éviter le contact avec tout objet métallique.
- Ne pas raccorder plus d'une électrode ou plus d'un câble de masse à une même borne de sortie de soudage.

Il reste une TENSION DC NON NÉGLIGEABLE dans les sources de soudage onduleur UNE FOIS l'alimentation coupée.

- Arrêter les convertisseurs, débrancher le courant électrique et décharger les condensateurs d'alimentation selon les instructions indiquées dans la partie Entretien avant de toucher les pièces.



LES PIÈCES CHAUDES peuvent provoquer des brûlures.

- Ne pas toucher à mains nues les parties chaudes.
- Prévoir une période de refroidissement avant de travailler à l'équipement.
- Ne pas toucher aux pièces chaudes, utiliser les outils recommandés et porter des gants de soudage et des vêtements épais pour éviter les brûlures.



LES FUMÉES ET LES GAZ peuvent être dangereux.

Le soudage génère des fumées et des gaz. Leur inhalation peut être dangereux pour votre santé.

- Eloigner votre tête des fumées. Ne pas respirer les fumées.
- À l'intérieur, ventiler la zone et/ou utiliser une ventilation forcée au niveau de l'arc pour l'évacuation des fumées et des gaz de soudage.
- Si la ventilation est médiocre, porter un respirateur anti-vapeurs approuvé.
- Lire et comprendre les spécifications de sécurité des matériaux (MSDS) et les instructions du fabricant concernant les métaux, les consommables, les revêtements, les nettoyants et les dégraissants.
- Travailler dans un espace fermé seulement s'il est bien ventilé ou en portant un respirateur à alimentation d'air. Demander toujours à un surveillant dûment formé de se tenir à proximité. Des fumées et des gaz de soudage peuvent déplacer l'air et abaisser le niveau d'oxygène provoquant des blessures ou des accidents mortels. S'assurer que l'air de respiration ne présente aucun danger.
- Ne pas souder dans des endroits situés à proximité d'opérations de dégraissage, de nettoyage ou de pulvérisation. La chaleur et les rayons de l'arc peuvent réagir en présence de vapeurs et former des gaz hautement toxiques et irritants.
- Ne pas souder des métaux munis d'un revêtement, tels que l'acier galvanisé, plaqué en plomb ou au cadmium à moins que le revêtement n'ait été enlevé dans la zone de soudure, que l'endroit soit bien ventilé, et en portant un respirateur à alimentation d'air. Les revêtements et tous les métaux renfermant ces éléments peuvent dégager des fumées toxiques en cas de soudage.



LES RAYONS DE L'ARC peuvent provoquer des brûlures dans les yeux et sur la peau.

Le rayonnement de l'arc du procédé de soudage génère des rayons visibles et invisibles intense (ultraviolets et infrarouges) susceptibles de provoquer des brûlures dans les yeux et sur la peau. Des étincelles sont projetées pendant le soudage.

- Porter un casque de soudage approuvé muni de verres filtrants appropriés pour protéger visage et yeux pour protéger votre visage et vos yeux pendant le soudage ou pour regarder (voir ANSI Z49.1 et Z87.1 énuméré dans les normes de sécurité).
- Porter des lunettes de sécurité avec écrans latéraux même sous votre casque.
- Avoir recours à des écrans protecteurs ou à des rideaux pour protéger les autres contre les rayonnements les éblouissements et les étincelles ; prévenir toute personne sur les lieux de ne pas regarder l'arc.
- Porter des vêtements confectionnés avec des matières résistantes et ignifuges (cuir, coton lourd ou laine) et des bottes de protection.



LE SOUDAGE peut provoquer un incendie ou une explosion.

Le soudage effectué sur des conteneurs fermés tels que des réservoirs, tambours ou des conduites peut provoquer leur éclatement. Des étincelles peuvent être projetées de l'arc de soudure. La projection d'étincelles, des pièces chaudes et des équipements chauds peut provoquer des incendies et des brûlures. Le contact accidentel de l'électrode avec des objets métalliques peut provoquer des étincelles, une explosion, un surchauffement ou un incendie. Avant de commencer le soudage, vérifier et s'assurer que l'endroit ne présente pas de danger.

- Déplacer toutes les substances inflammables à une distance de 10,7 m de l'arc de soudage. En cas d'impossibilité les recouvrir soigneusement avec des protections homologués.
- Ne pas souder dans un endroit où des étincelles peuvent tomber sur des substances inflammables.
- Se protéger et d'autres personnes de la projection d'étincelles et de métal chaud.
- Des étincelles et des matériaux chauds du soudage peuvent facilement passer dans d'autres zones en traversant de petites fissures et des ouvertures.
- Surveiller tout déclenchement d'incendie et tenir un extincteur à proximité.
- Le soudage effectué sur un plafond, plancher, paroi ou séparation peut déclencher un incendie de l'autre côté.
- Ne pas effectuer le soudage sur des conteneurs fermés tels que des réservoirs, tambours, ou conduites, à moins qu'ils n'aient été préparés correctement conformément à AWS F4.1 (voir les normes de sécurité).
- Ne soudez pas si l'air ambiant est chargé de particules, gaz, ou vapeurs inflammables (vapeur d'essence, par exemple).
- Brancher le câble de masse sur la pièce la plus près possible de la zone de soudage pour éviter le transport du courant sur une longue distance par des chemins inconnus éventuels en provoquant des risques d'électrocution, d'étincelles et d'incendie.
- Ne pas utiliser le poste de soudage pour dégeler des conduites gelées.
- En cas de non utilisation, enlever la baguette d'électrode du porte-électrode ou couper le fil à la pointe de contact.
- Porter des vêtements de protection dépourvus d'huile tels que des gants en cuir, une chemise en matériau lourd, des pantalons sans revers, des chaussures hautes et un couvre chef.
- Avant de souder, retirer toute substance combustible de vos poches telles qu'un allumeur au butane ou des allumettes.
- Une fois le travail achevé, assurez-vous qu'il ne reste aucune trace d'étincelles incandescentes ni de flammes.
- Utiliser exclusivement des fusibles ou coupe-circuits appropriés. Ne pas augmenter leur puissance; ne pas les ponter.
- Une fois le travail achevé, assurez-vous qu'il ne reste aucune trace d'étincelles incandescentes ni de flammes.
- Utiliser exclusivement des fusibles ou coupe-circuits appropriés. Ne pas augmenter leur puissance; ne pas les ponter.
- Suivre les recommandations dans OSHA 1910.252(a)(2)(iv) et NFPA 51B pour les travaux à chaud et avoir de la surveillance et un extincteur à proximité.

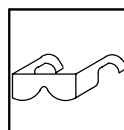

DES PIÈCES DE METAL ou DES SALETES peuvent provoquer des blessures dans les yeux.

- Le soudage, l'écaillage, le passage de la pièce à la brosse en fil de fer, et le meulage génèrent des étincelles et des particules métalliques volantes. Pendant la période de refroidissement des soudures, elles risquent de projeter du laitier.
- Porter des lunettes de sécurité avec écrans latéraux ou un écran facial.



LES ACCUMULATIONS DE GAZ risquent de provoquer des blessures ou même la mort.

- Fermer l'alimentation du gaz protecteur en cas de non-utilisation.
- Veiller toujours à bien aérer les espaces confinés ou se servir d'un respirateur d'adduction d'air homologué.



Les CHAMPS ÉLECTROMAGNÉTIQUES (CEM) peuvent affecter les implants médicaux.

- Les porteurs de stimulateurs cardiaques et autres implants médicaux doivent rester à distance.
- Les porteurs d'implants médicaux doivent consulter leur médecin et le fabricant du dispositif avant de s'approcher de la zone où se déroule du soudage à l'arc, du soudage par points, du gougeage, de la découpe plasma ou une opération de chauffage par induction.



LE BRUIT peut endommager l'ouïe.

Le bruit des processus et des équipements peut affecter l'ouïe.

- Porter des protections approuvées pour les oreilles si le niveau sonore est trop élevé.

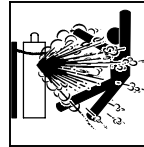

LES BOUTEILLES peuvent exploser si elles sont endommagées.

Des bouteilles de gaz protecteur contiennent du gaz sous haute pression. Si une bouteille est endommagée, elle peut exploser. Du fait que les bouteilles de gaz font normalement partie du procédé de soudage, les manipuler avec précaution.

- Protéger les bouteilles de gaz comprimé d'une chaleur excessive, des chocs mécaniques, des dommages physiques, du laitier, des flammes ouvertes, des étincelles et des arcs.
- Placer les bouteilles debout en les fixant dans un support stationnaire ou dans un porte-bouteilles pour les empêcher de tomber ou de se renverser.
- Tenir les bouteilles éloignées des circuits de soudage ou autres circuits électriques.
- Ne jamais placer une torche de soudage sur une bouteille à gaz.
- Une électrode de soudage ne doit jamais entrer en contact avec une bouteille.
- Ne jamais souder une bouteille pressurisée – risque d'explosion.
- Utiliser seulement des bouteilles de gaz protecteur, régulateurs, tuyaux et raccords convenables pour cette application spécifique ; les maintenir ainsi que les éléments associés en bon état.
- Détourner votre visage du détendeur-régulateur lorsque vous ouvrez la soupape de la bouteille.
- Le couvercle du détendeur doit toujours être en place, sauf lorsque la bouteille est utilisée ou qu'elle est reliée pour usage ultérieur.
- Utiliser les équipements corrects, les bonnes procédures et suffisamment de personnes pour soulever et déplacer les bouteilles.
- Lire et suivre les instructions sur les bouteilles de gaz comprimé, l'équipement connexe et le dépliant P-1 de la CGA (Compressed Gas Association) mentionné dans les principales normes de sécurité.

2-3. Dangers supplémentaires en relation avec l'installation, le fonctionnement et la maintenance



Risque D'INCENDIE OU D'EXPLOSION.

- Ne pas placer l'appareil sur, au-dessus ou à proximité de surfaces inflammables.
- Ne pas installer l'appareil à proximité de produits inflammables.
- Ne pas surcharger l'installation électrique – s'assurer que l'alimentation est correctement dimensionnée et protégée avant de mettre l'appareil en service.

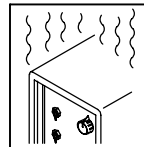

L'EMPLOI EXCESSIF peut SURCHAUFFER L'ÉQUIPEMENT.

- Prévoir une période de refroidissement ; respecter le cycle opératoire nominal.
- Réduire le courant ou le facteur de marche avant de poursuivre le soudage.
- Ne pas obstruer les passages d'air du poste.



LA CHUTE DE L'ÉQUIPEMENT peut provoquer des blessures.

- Utiliser l'anneau de levage uniquement pour soulever l'appareil, NON PAS les chariots, les bouteilles de gaz ou tout autre accessoire.
- Utiliser un équipement de levage de capacité suffisante pour lever l'appareil.
- En utilisant des fourches de levage pour déplacer l'unité, s'assurer que les fourches sont suffisamment longues pour dépasser du côté opposé de l'appareil.
- Tenir l'équipement (câbles et cordons) à distance des véhicules mobiles lors de toute opération en hauteur.
- Suivre les consignes du Manuel des applications pour l'équation de levage NIOSH révisée (Publication N°94-110) lors du levage manuel de pièces ou équipements lourds.

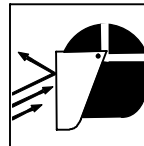

LES ÉTINCELLES PROJÉTÉES peuvent provoquer des blessures.

- Porter un écran facial pour protéger le visage et les yeux.
- Affûter l'électrode au tungstène uniquement à la meuleuse dotée de protecteurs. Cette manœuvre est à exécuter dans un endroit sûr lorsque l'on porte l'équipement homologué de protection du visage, des mains et du corps.
- Les étincelles risquent de causer un incendie – éloigner toute substance inflammable.

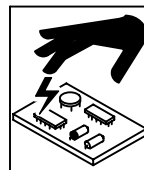

LES CHARGES ÉLECTROSTATIQUES peuvent endommager les circuits imprimés.

- Établir la connexion avec la barrette de terre avant de manipuler des cartes ou des pièces.
- Utiliser des pochettes et des boîtes antistatiques pour stocker, déplacer ou expédier des cartes de circuits imprimés.



Les PIÈCES MOBILES peuvent causer des blessures.

- Ne pas s'approcher des organes mobiles.
- Ne pas s'approcher des points de coincement tels que des rouleaux de commande.



LES FILS DE SOUDAGE peuvent provoquer des blessures.

- Ne pas appuyer sur la gâchette avant d'en avoir reçu l'instruction.
- Ne pas diriger le pistolet vers soi, d'autres personnes ou toute pièce mécanique en engageant le fil de soudage.



Les PIÈCES MOBILES peuvent causer des blessures.

- S'abstenir de toucher des organes mobiles tels que des ventilateurs.
- Maintenir fermés et verrouillés les portes, panneaux, recouvrements et dispositifs de protection.
- Lorsque cela est nécessaire pour des travaux d'entretien et de dépannage, faire retirer les portes, panneaux, recouvrements ou dispositifs de protection uniquement par du personnel qualifié.
- Remettre les portes, panneaux, recouvrements ou dispositifs de protection quand l'entretien est terminé et avant de rebrancher l'alimentation électrique.

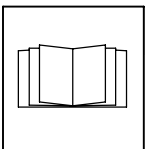

LIRE LES INSTRUCTIONS.

- Lire et appliquer les instructions sur les étiquettes et le Mode d'emploi avant l'installation, l'utilisation ou l'entretien de l'appareil. Lire les informations de sécurité au début du manuel et dans chaque section.
- N'utiliser que les pièces de rechange recommandées par le constructeur.
- Effectuer l'entretien en respectant les manuels d'utilisation, les normes industrielles et les codes nationaux, d'état et locaux.

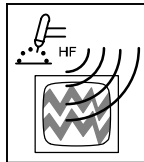

LE RAYONNEMENT HAUTE FRÉQUENCE (H.F.) risque de provoquer des interférences.

- Le rayonnement haute fréquence (H.F.) peut provoquer des interférences avec les équipements de radio-navigation et de communication, les services de sécurité et les ordinateurs.

- Demander seulement à des personnes qualifiées familiarisées avec des équipements électroniques de faire fonctionner l'installation.
- L'utilisateur est tenu de faire corriger rapidement par un électricien qualifié les interférences résultant de l'installation.
- Si le FCC signale des interférences, arrêter immédiatement l'appareil.
- Effectuer régulièrement le contrôle et l'entretien de l'installation.
- Maintenir soigneusement fermés les portes et les panneaux des sources de haute fréquence, maintenir les éclateurs à une distance correcte et utiliser une terre et un blindage pour réduire les interférences éventuelles.

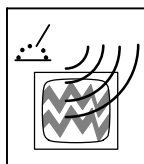

LE SOUDAGE À L'ARC risque de provoquer des interférences.

- L'énergie électromagnétique risque de provoquer des interférences pour l'équipement électronique sensible tel que les ordinateurs et l'équipement commandé par ordinateur tel que les robots.

- Veiller à ce que tout l'équipement de la zone de soudage soit compatible électromagnétiquement.
- Pour réduire la possibilité d'interférence, maintenir les câbles de soudage aussi courts que possible, les grouper, et les poser aussi bas que possible (ex. par terre).
- Veiller à souder à une distance de 100 mètres de tout équipement électronique sensible.
- Veiller à ce que ce poste de soudage soit posé et mis à la terre conformément à ce mode d'emploi.
- En cas d'interférences après avoir pris les mesures précédentes, il incombe à l'utilisateur de prendre des mesures supplémentaires telles que le déplacement du poste, l'utilisation de câbles blindés, l'utilisation de filtres de ligne ou la pose de protecteurs dans la zone de travail.

2-4. Proposition californienne 65 Avertissements

⚠ Les équipements de soudage et de coupage produisent des fumées et des gaz qui contiennent des produits chimiques dont l'État de Californie reconnaît qu'ils provoquent des malformations congénitales et, dans certains cas, des cancers. (Code de santé et de sécurité de Californie, chapitre 25249.5 et suivants)

⚠ Les batteries, les bornes et autres accessoires contiennent du plomb et des composés à base de plomb, produits chimiques dont l'État de Californie reconnaît qu'ils provoquent des cancers et des malformations congénitales ou autres problèmes de procréation. Se laver les mains après manipulation.

⚠ Ce produit contient des produits chimiques, notamment du plomb, dont l'État de Californie reconnaît qu'ils provoquent

des cancers, des malformations congénitales ou d'autres problèmes de procréation. Se laver les mains après utilisation.

Pour les moteurs à essence :

⚠ Les gaz d'échappement des moteurs contiennent des produits chimiques dont l'État de Californie reconnaît qu'ils provoquent des cancers et des malformations congénitales ou autres problèmes de procréation.

Pour les moteurs diesel :

⚠ Les gaz d'échappement des moteurs diesel et certains de leurs composants sont reconnus par l'État de Californie comme provoquant des cancers et des malformations congénitales ou autres problèmes de procréation.

2-5. Principales normes de sécurité

Safety in Welding, Cutting, and Allied Processes, ANSI Standard Z49.1, de Global Engineering Documents (téléphone : 1-877-413-5184, site Internet : www.global.ihc.com).

Safe Practices for the Preparation of Containers and Piping for Welding and Cutting, American Welding Society Standard AWS F4.1, de Global Engineering Documents (téléphone : 1-877-413-5184, site internet : www.global.ihc.com).

National Electrical Code, NFPA Standard 70, de National Fire Protection Association, Quincy, MA 02269 (téléphone : 800-344-3555, site Internet : www.nfpa.org et www.sparky.org).

Safe Handling of Compressed Gases in Cylinders, CGA Pamphlet P-1, de Compressed Gas Association, 4221 Walney Road, 5th Floor, Chantilly, VA 20151 (téléphone : 703-788-2700, site Internet : www.cganet.com).

Safety in Welding, Cutting, and Allied Processes, CSA Standard W117.2, de Canadian Standards Association, Standards Sales, 5060 Spectrum Way, Suite 100, Ontario, Canada L4W 5NS (téléphone : 800-463-6727, site internet : www.csa-international.org).

Safe Practice For Occupational And Educational Eye And Face Protection, ANSI Standard Z87.1, de American National Standards Institute,

25 West 43rd Street, New York, NY 10036 (téléphone : 212-642-4900, site Internet : www.ansi.org).

Standard for Fire Prevention During Welding, Cutting, and Other Hot Work, NFPA Standard 51B, de National Fire Protection Association, P.O. Box 9101, Quincy, MA 02269-9101 (téléphone : 617-770-3000, site Internet : www.nfpa.org).

OSHA, Occupational Safety and Health Standards for General Industry, Title 29, Code of Federal Regulations (CFR), Part 1910, Subpart Q, and Part 1926, Subpart J, de U.S. Government Printing Office, Superintendent of Documents, P.O. Box 371954, Pittsburgh, PA 15250-7954 (téléphone : 1-866-512-1800) (il y a 10 bureaux régionaux – le téléphone de la région 5, Chicago, est 312-353-2220, site Internet : www.osha.gov).

U.S. Consumer Product Safety Commission (CPSC), 4330 East West Highway, Bethesda, MD 20814 (téléphone : 301-504-7923, site internet : www.cpsc.gov).

Applications Manual for the Revised NIOSH Lifting Equation, The National Institute for Occupational Safety and Health (NIOSH), 1600 Clifton Rd, Atlanta, GA 30333 (téléphone : 1-800-232-4636, site internet : www.cdc.gov/NIOSH).

2-6. Informations relatives aux CEM

Le courant électrique qui traverse tout conducteur génère des champs électromagnétiques (CEM) à certains endroits. Le courant de soudage crée un CEM autour du circuit et du matériel de soudage. Les CEM peuvent créer des interférences avec certains implants médicaux comme des stimulateurs cardiaques. Des mesures de protection pour les porteurs d'implants médicaux doivent être prises: par exemple, des restrictions d'accès pour les passants ou une évaluation individuelle des risques pour les soudeurs. Tous les soudeurs doivent appliquer les procédures suivantes pour minimiser l'exposition aux CEM provenant du circuit de soudage:

1. Rassembler les câbles en les torsadant ou en les attachant avec du ruban adhésif ou avec une housse.
2. Ne pas se tenir au milieu des câbles de soudage. Disposer les câbles d'un côté et à distance de l'opérateur.
3. Ne pas courber et ne pas entourer les câbles autour de votre corps.

4. Maintenir la tête et le torse aussi loin que possible du matériel du circuit de soudage.
5. Connecter la pince sur la pièce aussi près que possible de la soudure.
6. Ne pas travailler à proximité d'une source de soudage, ni s'asseoir ou se pencher dessus.
7. Ne pas souder tout en portant la source de soudage ou le dévidoir.

En ce qui concerne les implants médicaux :

Les porteurs d'implants doivent d'abord consulter leur médecin avant de s'approcher des opérations de soudage à l'arc, de soudage par points, de gougeage, du coupage plasma ou de chauffage par induction. Si le médecin approuve, il est recommandé de suivre les procédures précédentes.

SECTION 3 – GMAW FUNDAMENTALS

3-1. Basic Information

A. Overview Of Welding Processes

The two basic types of metal transfer are short circuit and spray.

In short circuit transfer, the wire short circuits to the workpiece and weld wire is transferred with each short circuit. Short circuit transfer uses smaller wire diameters at lower arc voltages and higher slope settings. See Figure 3-1.

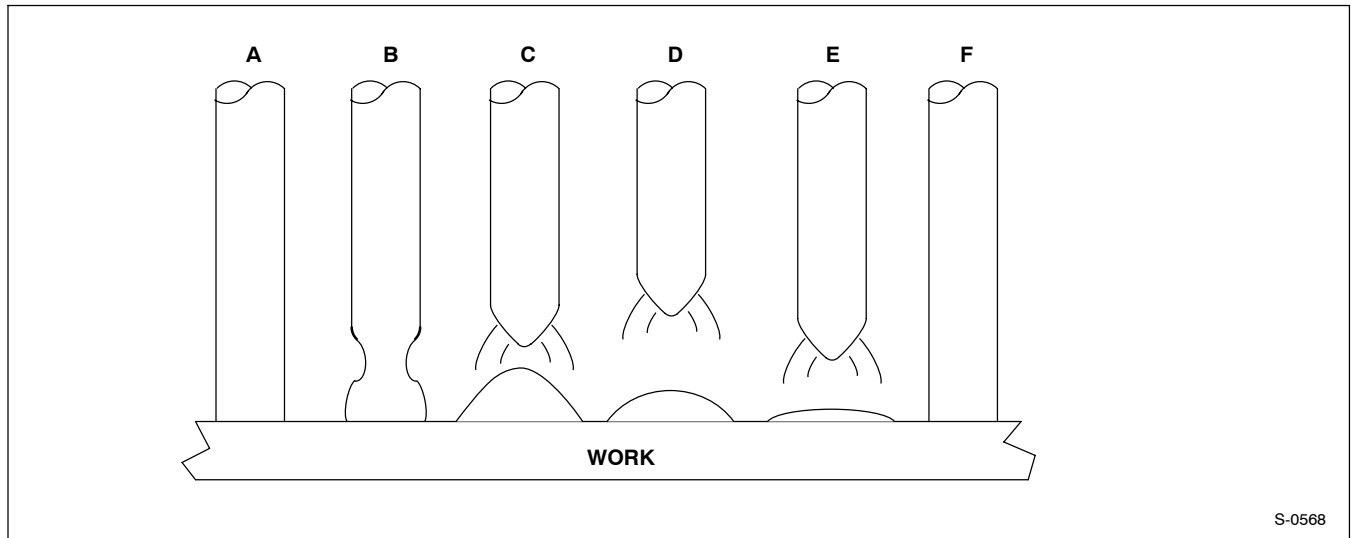

Figure 3-1. Mechanics Of Short Circuiting Transfer

In spray transfer, a steady stream of small droplets of weld wire are transferred into the weld. Spray transfer uses larger diameter wires at higher arc voltages and lower slope settings. See Figure 3-2.

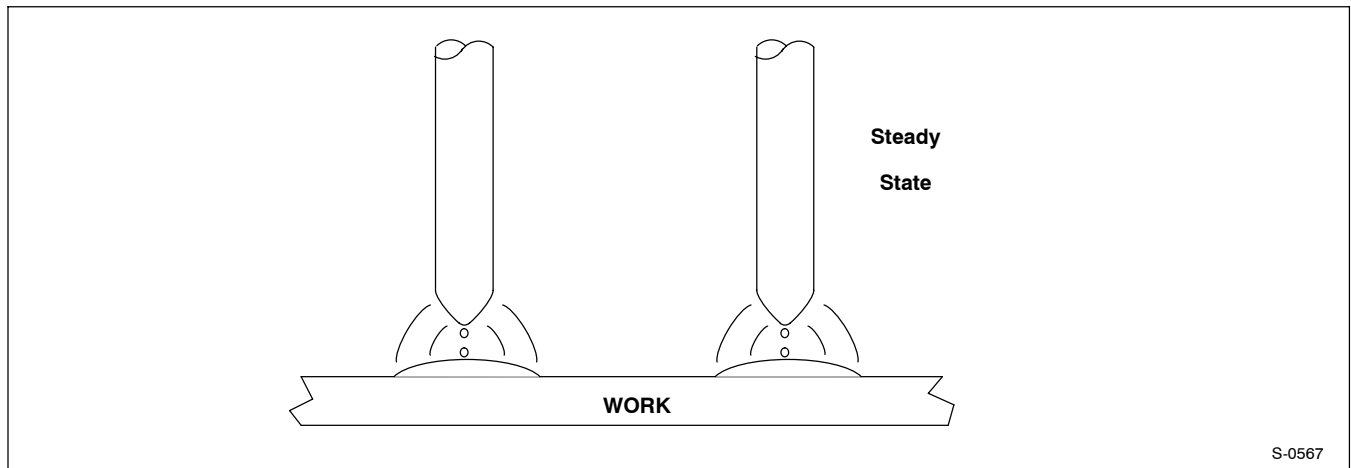

Figure 3-2. Mechanics Of Spray Transfer

For short circuit transfer, a constant voltage welding power source is required. Adjustable slope and inductance are desirable. Slope slows the response rate of the welding power source and lowers maximum short circuit current. A constant speed wire feeder is recommended for short circuit transfer.

For spray transfer, either a constant voltage or constant current welding power source can be used. A voltage sensing wire feeder is recommended for spray transfer.

The values in the following tables are a starting point for setting up a weld. Most settings can be varied while welding to fine tune the arc.

Table 3-1. Short Circuit Transfer For Mild And Low Alloy Steel*

Electrode Diameter	Amperage Range DCEP	Load Voltage	Power Source
.030 in.	70-130	15-21	CV
.035 in.	80-190	16-22	CV
.045 in.	100-225	17-22	CV

*Using CO₂ shielding gas for mild steel and Argon-CO₂ for low alloy steel.

Table 3-2. Spray Transfer For Mild And Low Alloy Steel*

Electrode Diameter	Amperage Range DCEP	Load Voltage	Power Source
.030 in.	150-265	24-28	CV or CC
.035 in.	175-290	24-28	CV or CC
.045 in.	200-315	24-30	CV or CC
1/16 in.	275-500	24-32	CV or CC
3/32 in.	350-600	24-33	CV or CC

*Using Argon - 5% Oxygen shielding gas or C10 - 90% Argon - 10% Oxygen shielding gas for mild and low alloy steel.

Table 3-3. Short Circuit Transfer For Stainless Steel 300 Series*

Electrode Diameter	Amperage Range DCEP	Load Voltage	Power Source
.030 in.	50-145	17-22	CV power source with characteristics for short circuiting transfer.
.035 in.	65-175	17-22	
.045 in.	100-210	17-22	

*Using tri-gas mixture – 90% He; 7-1/2% A; 2-1/2% CO₂ and flow rates of approximately 20 CFH.

Table 3-4. Spray Transfer For Stainless Steel 300 Series*

Electrode Diameter	Amperage Range DCEP	Load Voltage	Power Source
.030 in.	160-210	24-28	CV or CC
.035 in.	180-255	24-29	CV or CC
.045 in.	200-300	24-30	CV or CC
1/16 in.	215-325	24-32	CV or CC
3/32 in.	225-375	24-32	CV or CC

*Using Argon-Oxygen shielding gas. Oxygen percentage varies from 1 - 5%.

Table 3-5. Flux Cored Arc*

Electrode Diameter	Amperage Range	Load Voltage
.045 in.	200-300	24-30
1/16 in.	200-425	24-29
5/64 in.	250-450	27-31
3/32 in.	300-500	29-33
7/64 in.	360-550	29-34
1/8 in.	425-650	29-34

*Using CO₂ as the shielding gas. Flow rates depend on nozzle diameter, surrounding air movement, and electrode extension ♦. Welding in still air generally requires flow rates from 30 to 40 CFH. Drafty conditions or longer electrode extension may require higher flow rates.

♦ Most manufacturers recommend an extension of 3/4 to 1-1/2 in. for gas shielded electrodes. Follow the electrode manufacturer's recommendations.

B. Advanced Process: RMD And Pro-Pulse

RMD (Regulated Metal Deposition)

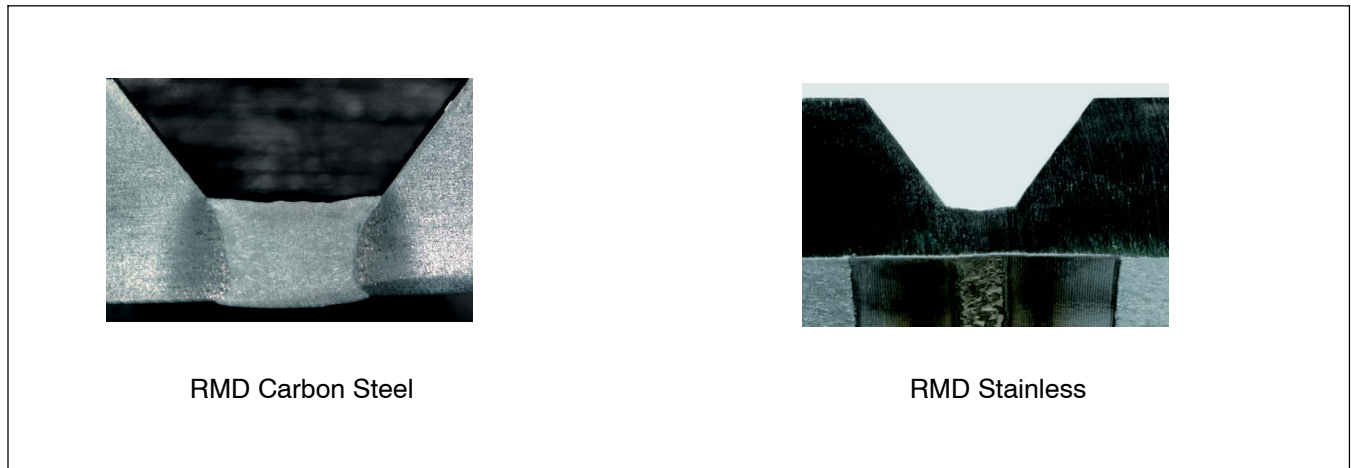

Figure 3-3. RMD Root Pass Welds

A precisely controlled short-circuit metal transfer that provides a calm, stable arc and weld puddle. This provides less chance of cold lap or lack of fusion, less spatter and a higher quality root pass on pipe. The stability of the weld process lessens the puddle manipulation required by the operator and is more tolerant to hi-lo conditions, reducing training requirements. Weld bead profiles are thicker than conventional root pass welds which can eliminate the need for a hot pass, improving weld productivity. In some stainless steel applications, it may be possible to eliminate the backing (purge) gas to further improve productivity and reduce welding costs.

- Ideally suited to root pass welding
- Consistent side wall fusion
- Less weld spatter
- Tolerant to hi-lo fit-up conditions
- More tolerant of changes in tip-to-work distance
- Less personnel training time
- Thicker root passes can eliminate hot pass
- Eliminate backing gas on some stainless steel applications

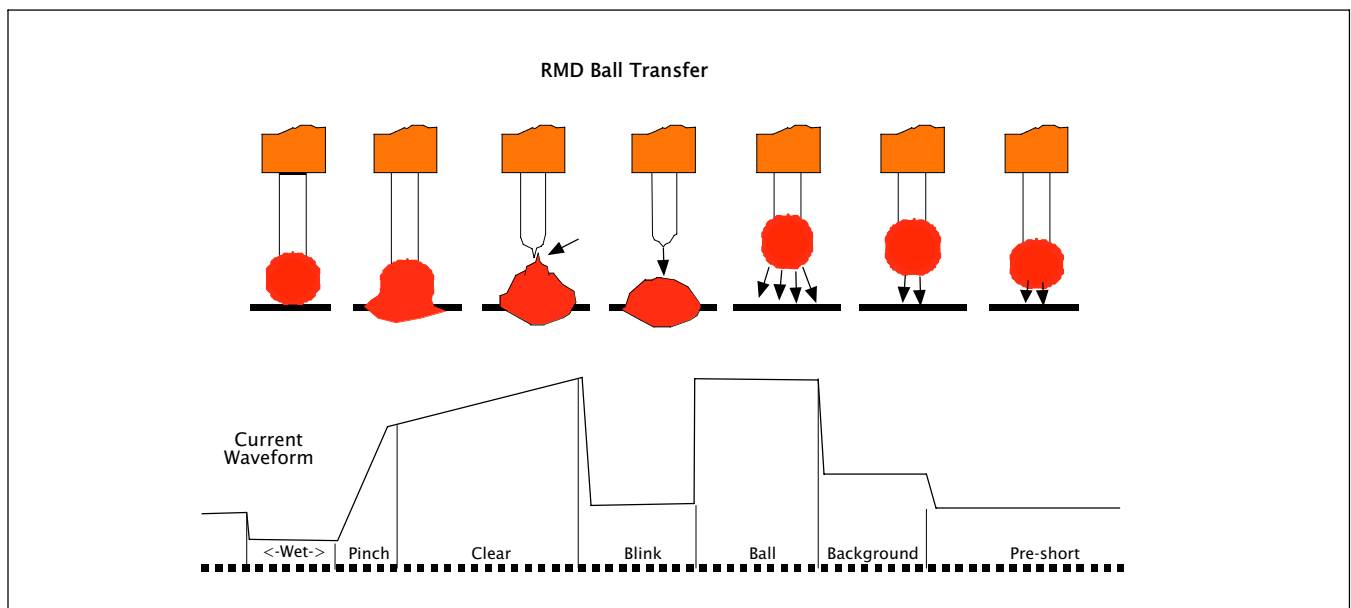

Figure 3-4. RMD Ball Transfer

Pro-Pulse

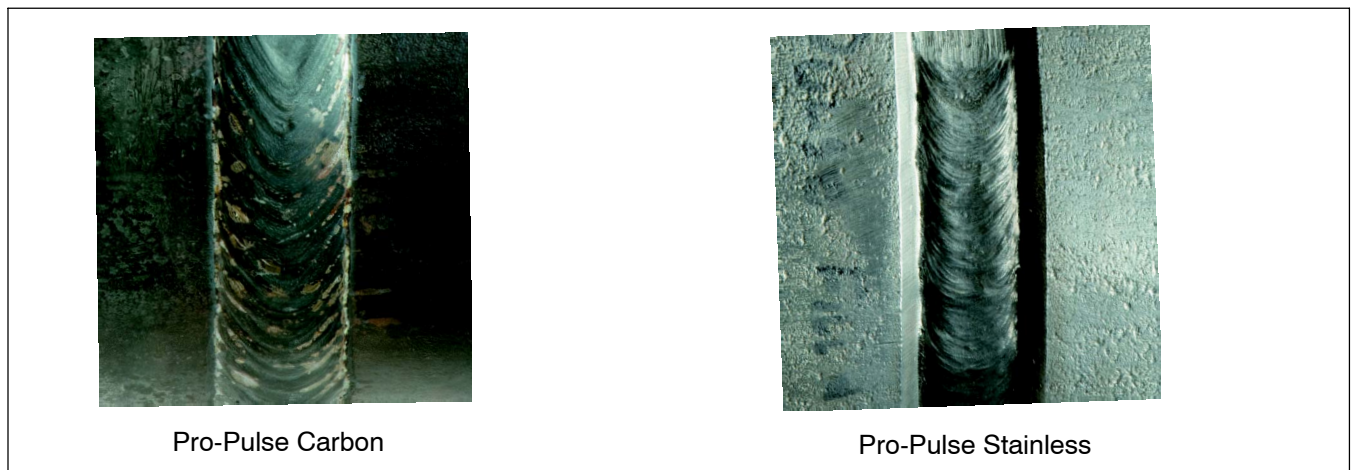

Figure 3-5. Pro-Pulse Weld Bead

This method of pulse welding provides a shorter arc length, narrower arc cone and less heat input than with traditional spray pulse transfer. Since the process is synergic, arc wandering and variations in tip-to-work distances are virtually eliminated. This provides easier puddle control for both in-position and out-of-position welding, reducing personnel training time. The process also improves fusion at the toe of the weld, permitting higher travel speeds and higher deposition. This process coupled with RMD Pro, for root pass welding, permits welding procedures with one wire and one gas to eliminate process switch-over time.

- Ideally suited to fill and cap pass welding
- Easier puddle control than conventional spray pulse
- Shorter arc lengths and narrow arc cone for out-of-position welding
- More tolerant of tip-to-work variation
- Improve fusion and fill at toe of weld
- Less heat input reduces interpass cooling time and improves weld cycle time
- Enables one-wire and one-gas weld procedures

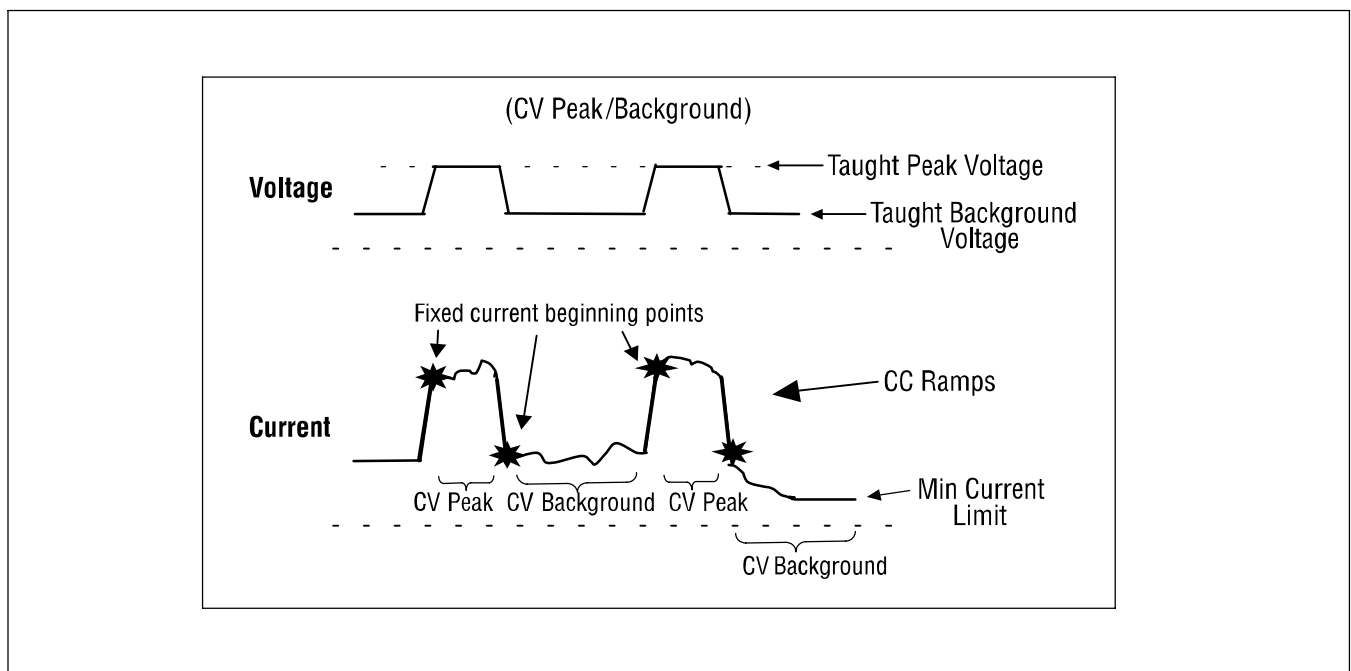

Figure 3-6. Pro-Pulse Voltage And Current Waveforms

3-2. Welding Positions

Welding position is determined by the pipe position and if the pipe is in a fixed position or rotating.

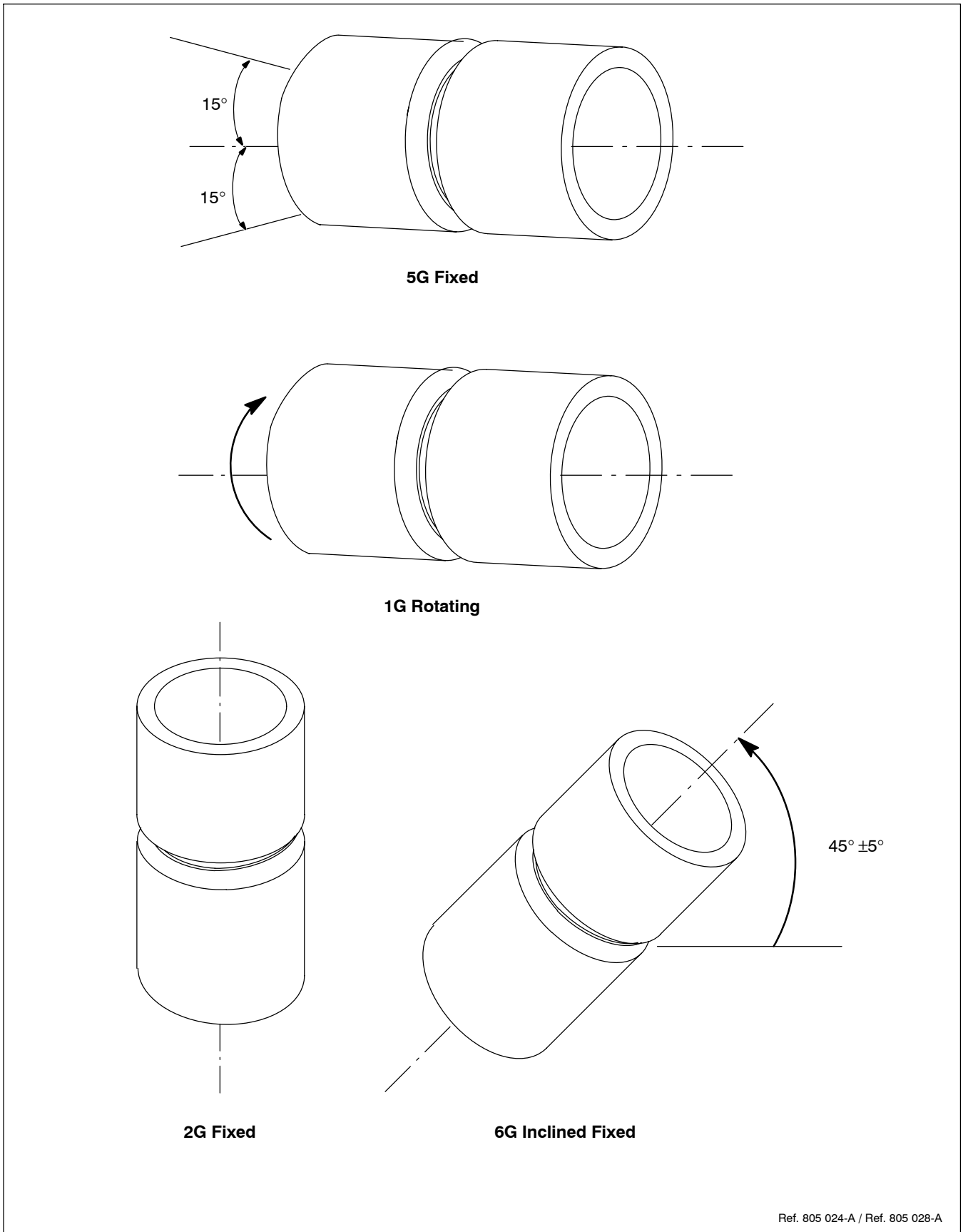
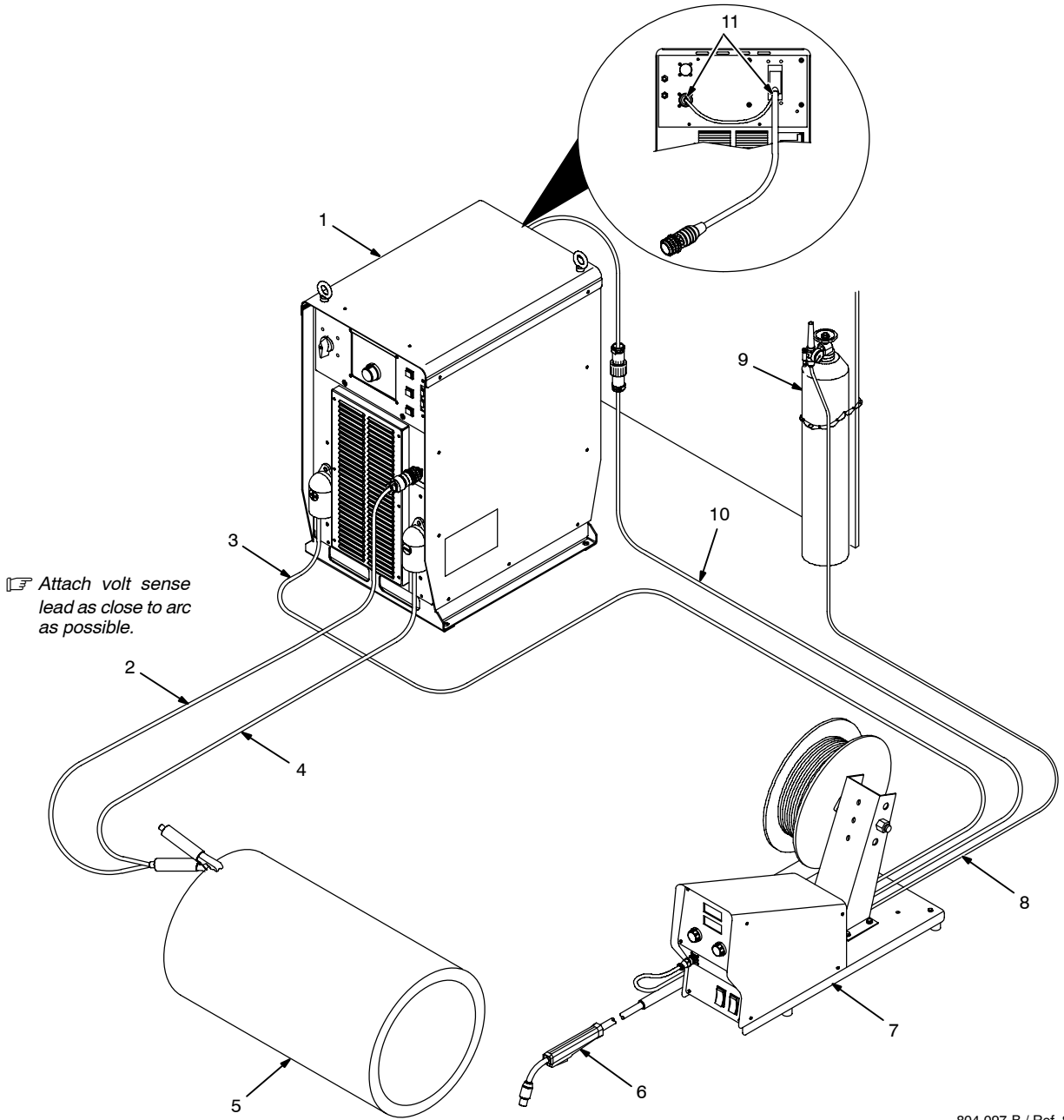

Figure 3-7. Pipe Positions

3-3. GMAW (MIG) / FCAW PipePro System



☞ Attach volt sense lead as close to arc as possible.

804 097-B / Ref. 804 374-C

- ⚠ Do not mount feeder on top of power source.**
- ⚠ Do not put feeder where welding wire hits cylinder.**
- ⚠ Do not move or operate equipment when it could tip.**
- 1 Welding Power Source
- ☞ Attach volt sense lead as close to arc as possible.

- 2 Negative Volt Sense Cable
- 3 Positive (+) Weld Cable
- 4 Negative (-) Weld Cable
- 5 Workpiece
- 6 Welding Gun
- 7 Wire Feeder
- 8 Gas Hose
- 9 Gas Cylinder

- 10 14-Pin Feeder Control Cable
- 11 Interconnect Cable
- Connect 14-pin socket into wire feeder control cable or optional extension cable. Connect 72-pin connector to I/O receptacle RC72 on rear of power source. Connect 10-pin connector into receptacle RC8 on rear of power source.
- ☞ Maximum cable length not to exceed 150 feet.

3-4. Typical PipeWorx Connection Diagram For MIG (GMAW) Equipment With Feeder On Power Source

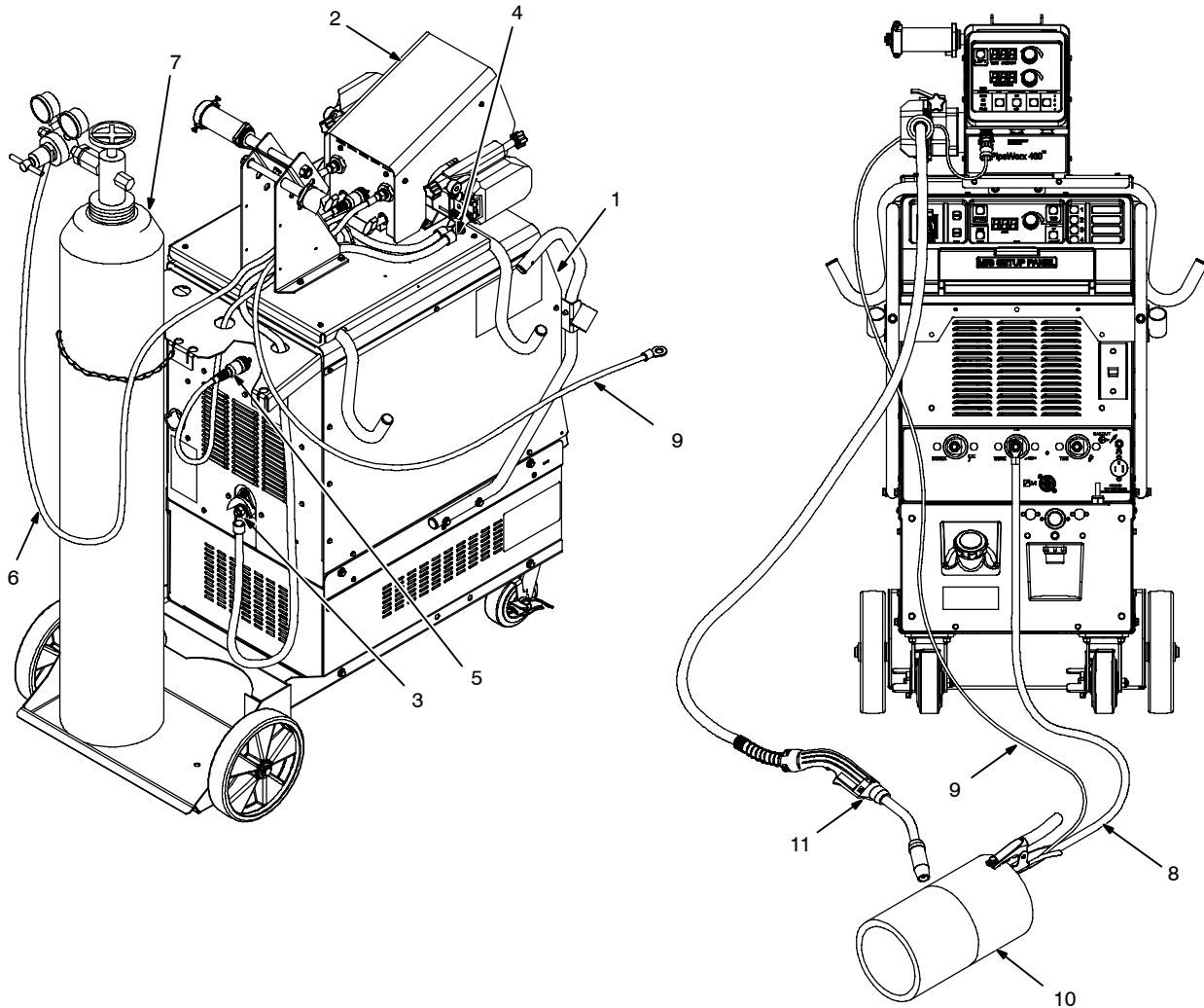

805 144-B

- ⚠ Do not put feeder where welding wire hits cylinder.**
- ⚠ Do not move or operate equipment when it could tip.**

- 1 Welding Power Source
- 2 Wire Feeder
- 3 MIG Connection
- 4 Positive (+) Weld Cable
- 5 Feeder Control Cable Connection

- 6 Gas Hose
- 7 Gas Cylinder

Connect 14-pin plug to rear of power source, and connect 14-socket plug to rear of wire feeder. Connect one end of weld cable to weld terminal on rear of power source. Connect remaining end of weld cable to wire feeder drive housing. Connect one end of gas hose to regulator/flowmeter on gas cylinder and connect remaining end

of gas hose to gas solenoid connector on rear of feeder or Y-hose for dual wire feeder.

- 8 Work (-) Weld Cable

☞ Attach volt sense lead to work clamp and attach work clamp as close to arc as possible.

- 9 Volt Sense Cable
- 10 Workpiece
- 11 Welding Gun

3-5. Typical PipeWorx Connection Diagram For MIG (GMAW) Equipment With Feeder On Cart

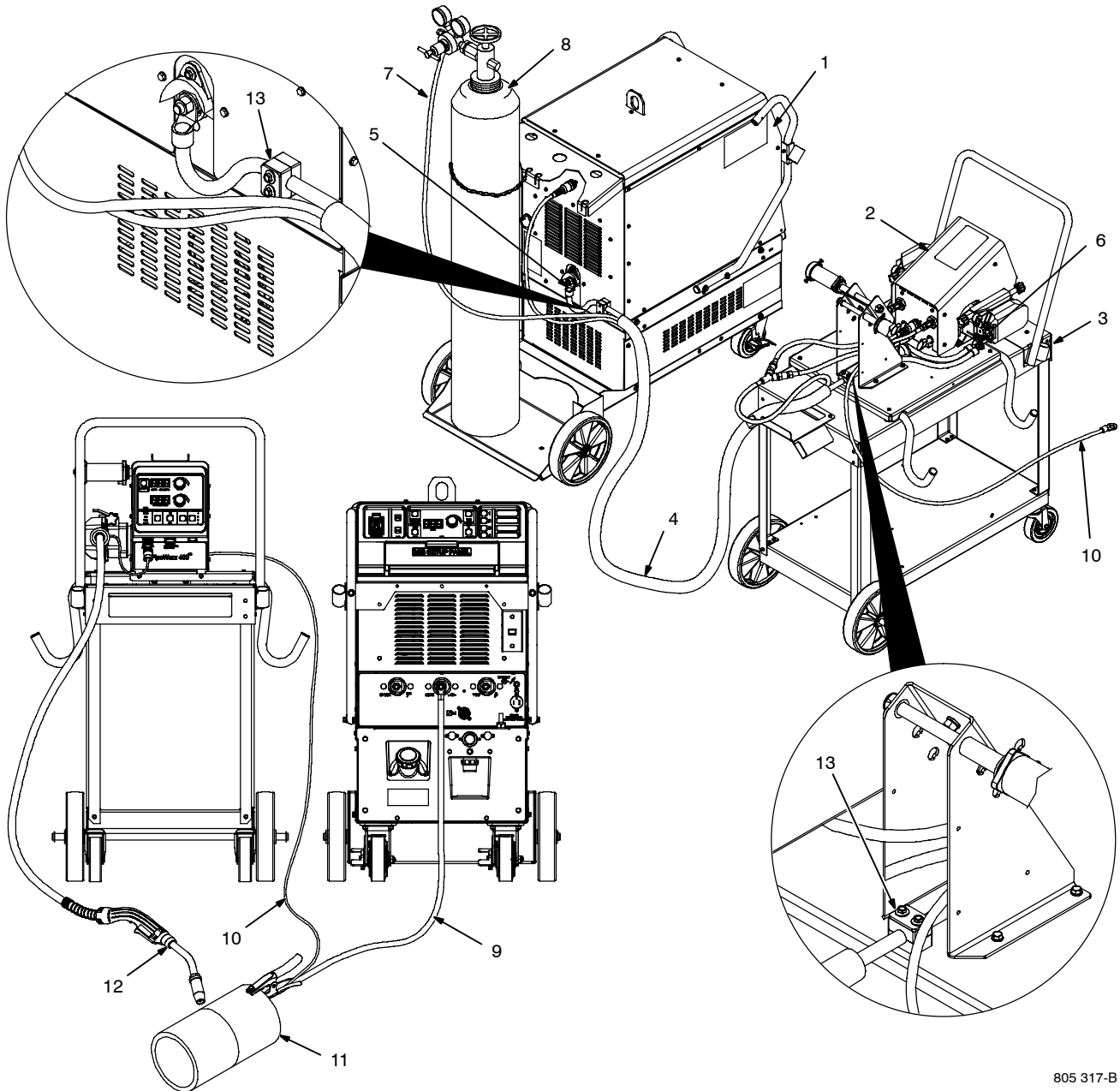

805 317-B

- ⚠ Do not put feeder where welding wire hits cylinder.**
- ⚠ Do not move or operate equipment when it could tip.**
- 1 Welding Power Source
- 2 Wire Feeder
- 3 Feeder Cart
- 4 Composite Cable
- 5 MIG Connection
- 6 Positive (+) Weld Cable
- 7 Gas Hose

8 Gas Cylinder
 Locate end of composite cable where gas hose extends out of sleeve approximately 50 inches (1270 mm). This end of the composite cable connects to the power source. Connect 14-pin plug to rear of power source, and connect 14-socket plug to rear of wire feeder. Connect one end of weld cable to weld terminal on rear of power source and secure cable in clamp block on rear panel. Connect remaining end of weld cable to wire feeder drive housing and secure cable in clamp block on feeder base. Connect one end of gas hose to regulator/flowmeter on gas cylinder and

connect remaining end of gas hose to gas solenoid connector on rear of feeder or Y-hose for dual wire feeder.

9 Work (-) Weld Cable (2/0 minimum)

☞ Attach volt sense lead to work clamp and attach work clamp as close to arc as possible.

10 Volt Sense Cable

11 Workpiece

12 Welding Gun

13 Strain Relief Clamp

3-7. Joint Preparation And Typical Recommendations For 1G, 5G, 6G, And 6GR

- **Establish Good Technique**

As with any welding process, success with the RMD process requires establishing and maintaining good preparation and welding techniques. The following guidelines, which are extremely easy to follow, lead to proven success and increased productivity for welding stainless steel pipe.

Start with pipe joint sections that have the standard 37.5 degree bevels, for a total included angle of 75 degrees. The lands can range from a knife edge to 3/32 in. Use a minimum 1/8 in. root opening to ensure proper root reinforcement on the weld's backside. An easy way to space the gap is with a filler rod that matches the desired gap size.

- **Tack Welding System**

Tack the pipe with the RMD process, making tacks (in this order) at the 12-, 6-, 3-, and 9-o'clock positions. Remove the filler metal spacer after making the first tack, then check the gap with a tool designed for that purpose. Tacks on smaller diameter pipe can be 1/4- to 1/2-in. long. Tack on larger pipe may be 1 in. or longer. Note that tack welds will shrink during cooling, causing the gap to close up. In areas with less than a 1/8-in. gap, grind the joint using a 3/32-in. cutting wheel to open the root. Finish preparing the pass by grinding each tack weld to a feather edge to ensure that the root pass consumes the tack weld.

- **Welding In The 1G Rolled Position**

Start the arc in the center of a tack around the 1:30- to 2-o'clock position. Hold the gun perpendicular to the pipe with a 5- to 10-degree drag angle. Use a 3/8- to 5/8-in. electrode stick-out. In some cases, this may require a recessed contact tip to help maintain correct stick-out.

Establish the weld puddle and position the electrode in the center of the weld puddle at the pipe rolls away from the operator (essentially, the operator is dragging the weld puddle). Watch the puddle closely to ensure that it ties into the sidewalls. Normally, do not use a weave technique. However, if the gap is greater than 3/16-in., the operator may need to weave the electrode slightly across the gap and up the sidewall to bridge it.

When the electrode is properly positioned in the weld puddle, the RMD process creates a muted buzzing sound that is much softer than the "cracking bacon" sound of traditional short circuit GMAW.

Although the RMD process appears colder than typical GMAW, the weld puddle fuses into the sidewall and penetrates the joint due to the calm metal transfer and stable arc. The face of a good root weld appears flat (neither concave or convex) and, as noted, it is thicker than a traditional GMAW root.

With traditional GMAW, operators position the arc on the leading edge of the puddle. Do not do this with RMD, as the arc will stutter and create spatter and greater penetration on the inside of the pipe (note that an optimum root has about a 1/16-in. reinforcement). If travel speeds become too slow and the electrode becomes unstable (listen for a sound more like traditional GMAW. Also, the weld face will be convex. If this happens, grind out the high spots to prevent areas of lack of fusion on the next pass).

If the joint is misaligned, continue to concentrate the arc in the center of the joint. Do not favor the high side of the joint; the new technology will automatically compensate. Let the arc do the work.

- **Welding In The 5G Fixed Position**

Begin welding in the 12-o'clock position. As with the 1G position, start the arc in the center of a tack weld using a 5- to 10-degree drag angle and a 3/8- to 5/8-in. stick-out. At the start of the weld, keep the arc in the center of the puddle, but move the electrode back and forth across the gap using a half moon motion (with the face of the moon pointing down).

At about the 1-o'clock position, gravity starts to push the puddle down the joint. Once gravity takes over, stop weaving and concentrate on directing the electrode into the center of the weld puddle. At about the 5-o'clock position, use a slight side-to-side motion until reaching 6-o'clock, ending the bead on the feathered tack weld. The side-to-side motion flattens the weld bead and minimizes grinding.

If the weld does not end on a tack weld (e.g., the operator breaks the arc for whatever reason), this may lead to a pin-hole at the end of the weld. Grind out the end of the weld before resuming. After completing the root pass, also grind out starts, stops and high points before making the first fill pass (remember that the root pass with the modified process can eliminate the hot pass).

3-8. RMD Open Root Joint Preparation

1. Bevel pipe end to 37.5° (standard pipe bevel) leaving a $1/16$ to $3/32$ in. (1.6 to 2.4 mm) land.

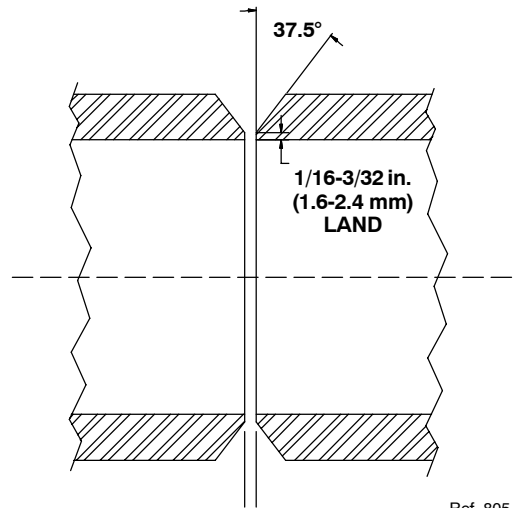

Ref. 805 029-A

2. Align pipe ends together leaving a minimum of $1/8$ in. (3.2 mm) gap.

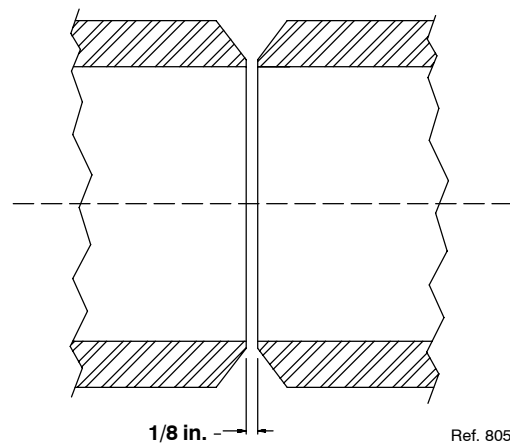

Ref. 805 029-A

3. Tack pipe ends together in four locations approximately 90° apart and 1 in. (25.4 mm) long on pipe that is 6 in. (152.4 mm) or larger diameter. Use appropriate sized tack welds on smaller pipe.

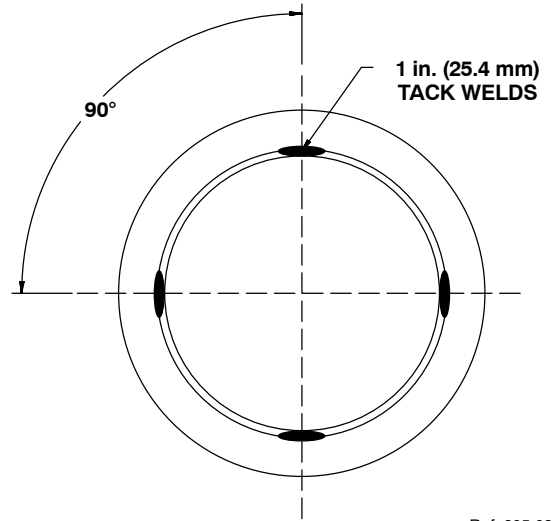

Ref. 805 029-A

4. Grind each end of the tack weld to a feather edge (knife edge).

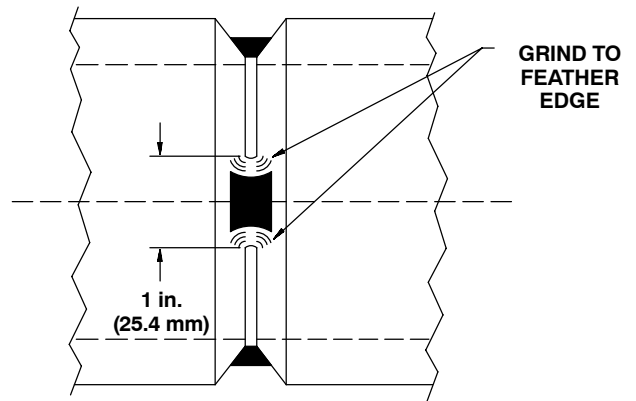

Ref. 805 029-A

3-9. 5G Welding Technique Recommendations

1. Start arc on sidewall or in center of tack weld, not in the gap.

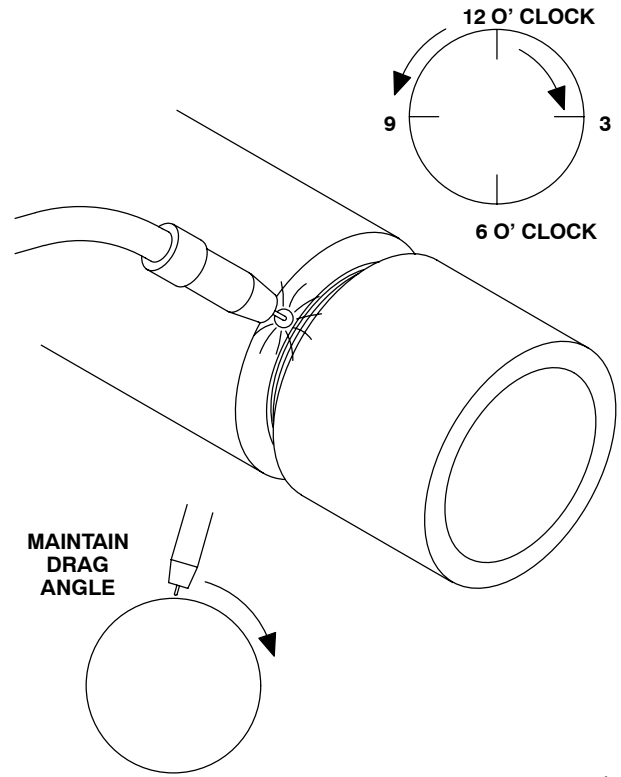

805 024-A

2. After puddle is established, maintain the arc on the center of the puddle with a 1/2 to 5/8 in. (12.7 to 15.9 mm) tip to work distance.

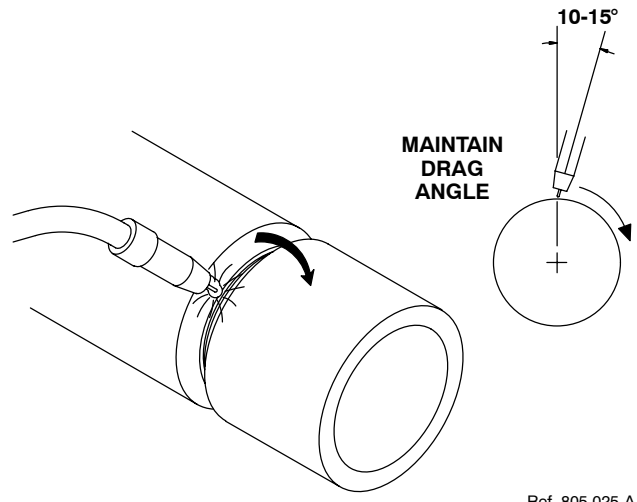

Ref. 805 025-A

3. Move across the gap.

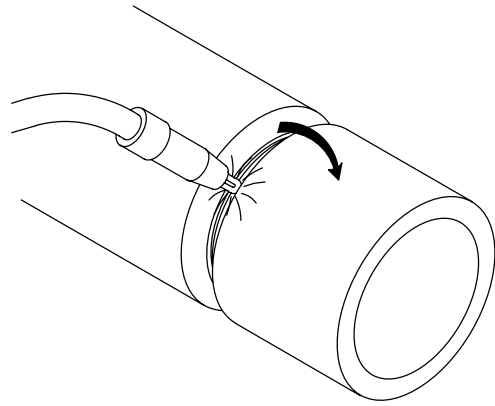

Ref. 805 025-A

4. Move slightly up the sidewall.

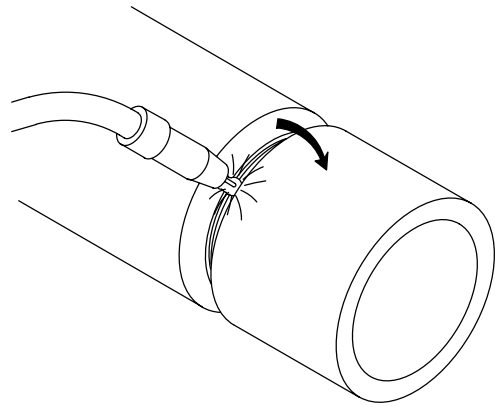

Ref. 805 025-A

5. Stay in the puddle and move the electrode back across the gap. Move the electrode down the joint in a half-moon motion.

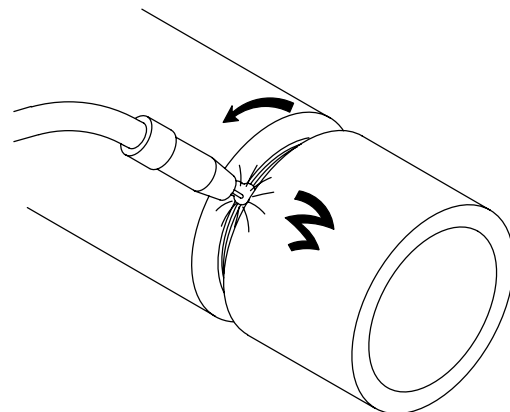

Ref. 805 025-A

- Continue moving back and forth (weaving) across the gap until reaching the 1 o'clock position.

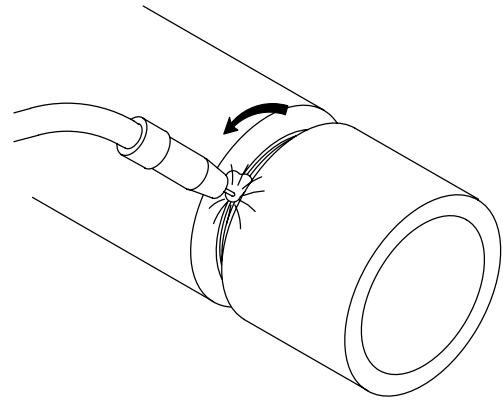

Ref. 805 025-A

- At the 1 o'clock position, stop weaving. Concentrate the arc on the center of the weld puddle and move down the pipe joint until the 5 o'clock position.

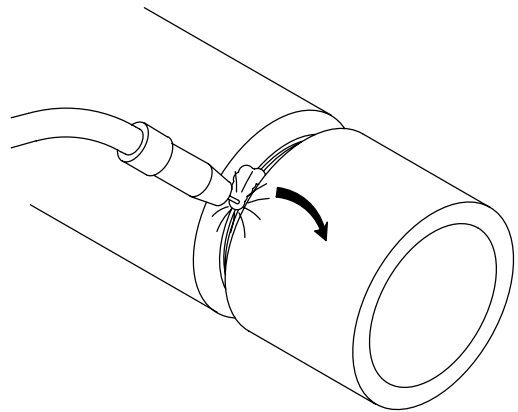

805 026-A

- At the 5 o'clock position, repeat steps 3 – 6. However, at Step 6 the instruction should read “until reaching the 6 o'clock position” instead of the 1 o'clock position.

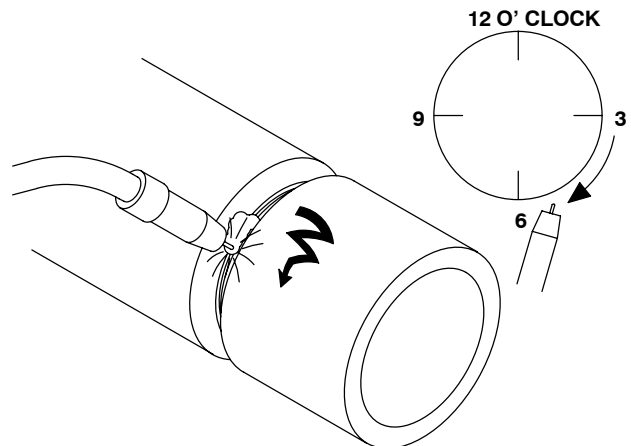

805 027-A

9. End the weld at the 6 o'clock position by moving the electrode onto the feathered tack weld.

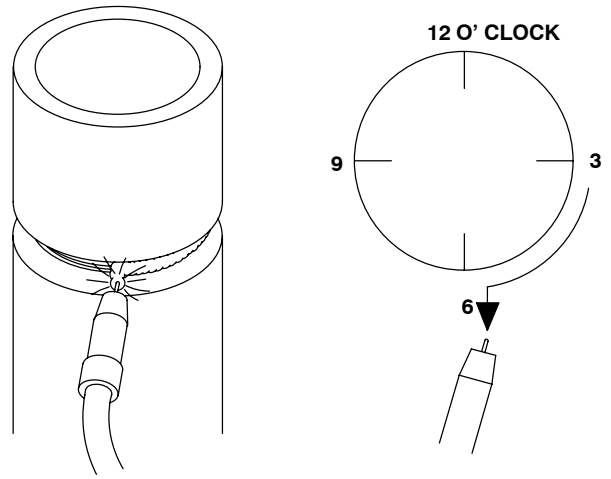

805 028-A

10. DO NOT stop welding in the root. This may cause pin holes.
Be sure to grind the weld at the stop position to ensure pinhole is removed and weld is feathered.

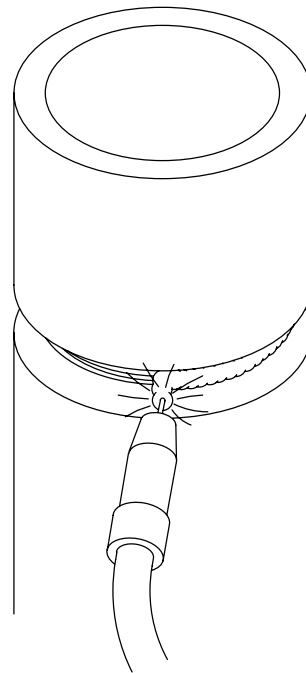

Ref. 805 028-A

11. When root weld is complete, remove excess silicon with a wire wheel or with light grinding.
Also, grind any high spots on root pass to make it uniform in height.

3-10. 1G Welding Technique Recommendations

1. Start arc on sidewall or in center of tack weld, not in the gap.

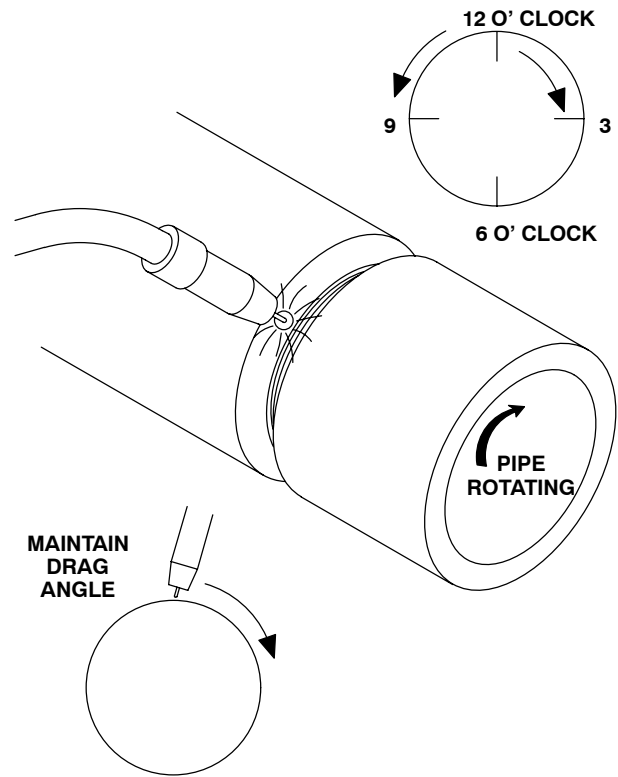

805 024-A

2. After puddle is established, maintain the arc on the leading edge of the puddle with a 1/4 to 1/2 in. (6.4 to 12.7 mm) tip to work distance.

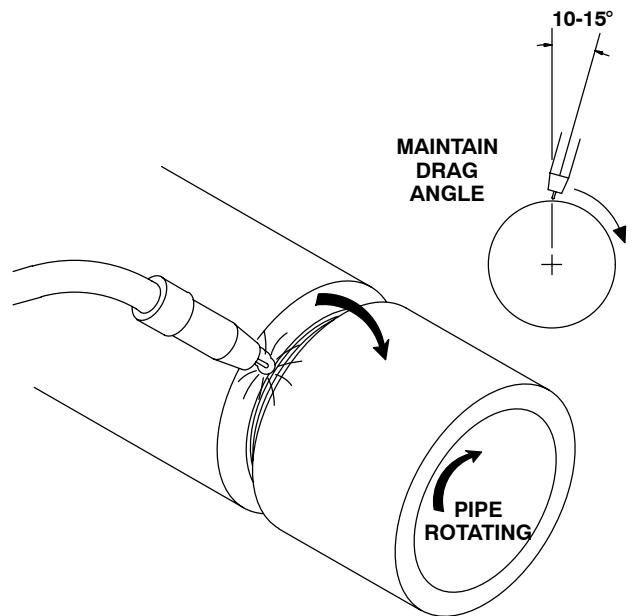

Ref. 805 025-A

3. Move across the gap. Watch the puddle, not the arc.

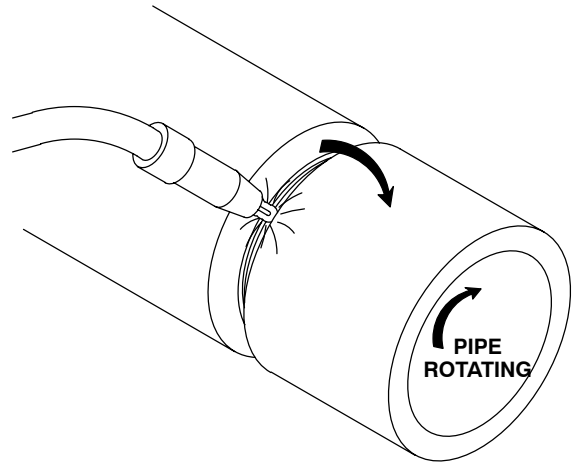

Ref. 805 025-A

4. Move slightly up the sidewall. Keep the electrode near the top of the pipe joint.

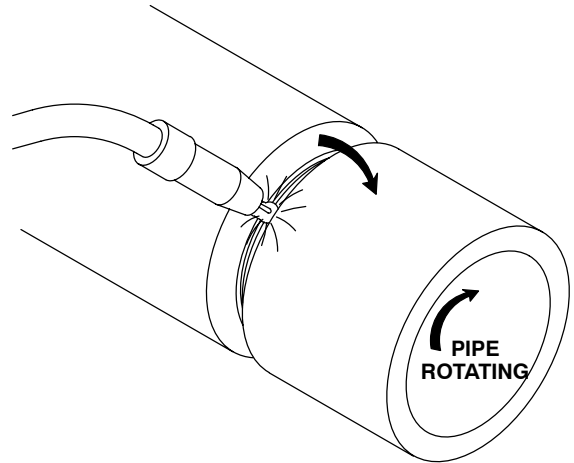

Ref. 805 025-A

5. Stay on the leading edge of the puddle and move the electrode back across the gap. Move the electrode in a half-moon motion.

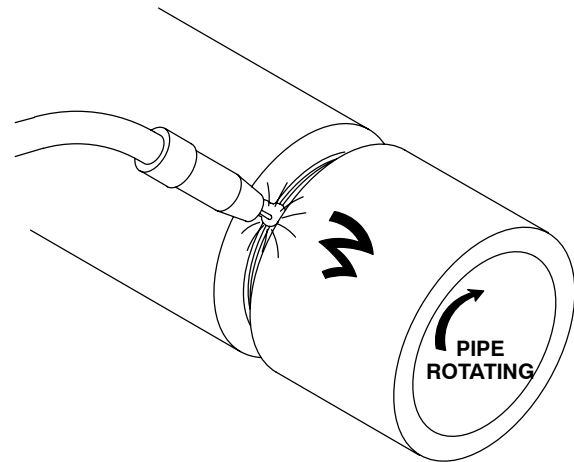

Ref. 805 025-A

- Continue moving back and forth (weaving) across the gap. Be sure pipe rotates at a constant speed. Maintain a steady arc length.

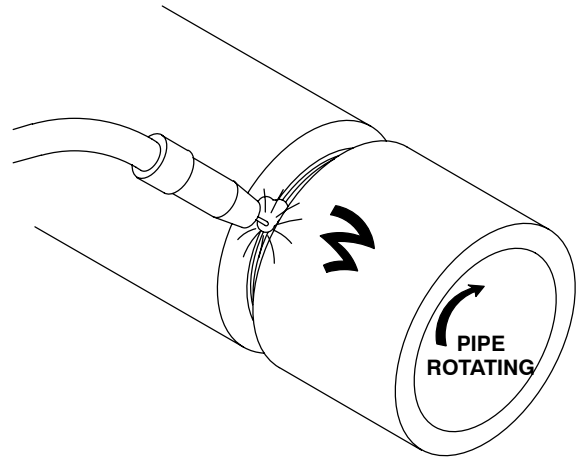

Ref. 805 025-A

- DO NOT** stop welding in the root. This may cause pin holes. Fill the crater by welding into the previous weld start. Use a short arc length to control heat. Be sure to grind the weld at the stop position to ensure any pinhole is removed and weld is feathered.

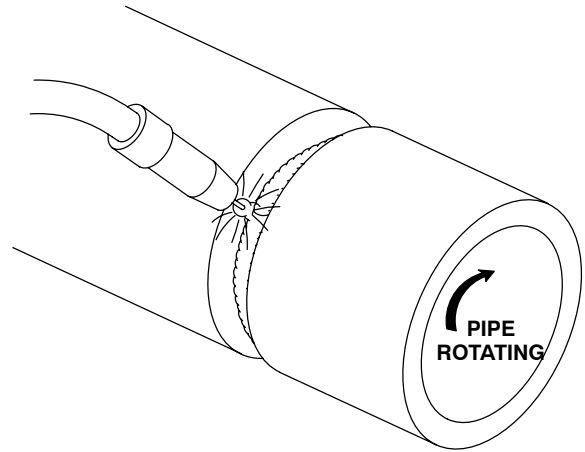

Ref. 805 028-A

- When root weld is complete, remove excess silicon with a wire wheel or with light grinding. Also, grind any high spots on root pass to make it uniform in height.

3-11. Welding Passes And Appropriate Process With Parameter Ranges

A. Welding Process Data

Table 3-6. PipePro 450 RFC Welding Programs

Steel					
Process	Wire Size in (mm)	Wire Feed Speed IPM (mpm)	Arc Adjust/Trim	Arc Control	Shielding Gas
RMD Steel	.035 (0.9)	100-300 w/200 Nominal (2.5-7.7 w/5.1 Nominal)	47-53 w/50 Nominal	25	90/10
	.035 (0.9)	100-300 w/200 Nominal (2.5-7.7 w/5.1 Nominal)	47-53 w/50 Nominal	25	85/15
	.035 (0.9)	100-300 w/200 Nominal (2.5-7.7 w/5.1 Nominal)	47-53 w/50 Nominal	25	75/25
	.035 (0.9)	100-300 w/200 Nominal (2.5-7.7 w/5.1 Nominal)	47-53 w/50 Nominal	25	CO ₂
	.040 (1.0)	100-275 w/175 Nominal (2.5-7.0 w/4.4 Nominal)	50-55 w/53 Nominal	25	90/10
	.040 (1.0)	100-275 w/175 Nominal (2.5-7.0 w/4.4 Nominal)	47-53 w/50 Nominal	25	85/15
	.040 (1.0)	100-275 w/175 Nominal (2.5-7.0 w/4.4 Nominal)	50-55 w/53 Nominal	25	75/25
	.040 (1.0)	100-275 w/175 Nominal (2.5-7.0 w/4.4 Nominal)	50-55 w/53 Nominal	25	CO ₂
	.045 (1.1)	100-200 w/150 Nominal (2.5-5.1 w/3.8 Nominal)	47-53 w/50 Nominal	25	90/10
	.045 (1.1)	100-200 w/150 Nominal (2.5-5.1 w/3.8 Nominal)	47-53 w/50 Nominal	25	85/15
	.045 (1.1)	100-200 w/150 Nominal (2.5-5.1 w/3.8 Nominal)	47-53 w/50 Nominal	25	75/25
	.045 (1.1)	100-200 w/150 Nominal (2.5-5.1 w/3.8 Nominal)	47-53 w/50 Nominal	25	CO ₂
ProPulse Steel Using A Positioner (Rolling The Pipe)	.035 (0.9)	225-600 w/250 Nominal (5.7-15.2 w/6.4 Nominal)	52-57 w/56 Nominal	25	90/10
	.035 (0.9)	120-780 w/250 Nominal 3.0-19.8 w/6.4 Nominal	52-57 w/56 Nominal	30-35	85/15
	.040 (1.0)	120-600 w/250 Nominal 3.0-15.2 w/6.4 Nominal	52-56 w/56 Nominal	25	90/10
	.040 (1.0)	120-600 w/250 Nominal 3.0-15.2 w/6.4 Nominal	52-56 w/56 Nominal	25	85/15
	.045 (1.1)	140-500 w/250 Nominal (3.6-12.7 w/6.4 Nominal)	52-57 w/56 Nominal	25	90/10
	.045 (1.1)	140-500 w/250 Nominal (3.6-12.7 w/6.4 Nominal)	52-57 w/56 Nominal	25	85/15

Table 3-6. PipePro 450 RFC Welding Programs (Continued)

Steel					
Process	Wire Size in (mm)	Wire Feed Speed IPM (mpm)	Arc Adjust/Trim	Arc Control	Shielding Gas
ProPulse Steel Welding In Position	.035 (0.9)	120-780 w/200 Nominal (3.0-19.8 w/5.1 Nominal)	52-57 w/54 Nominal	25	90/10
	.035 (0.9)	120-780 w/200 Nominal (3.0-19.8 w/5.1 Nominal)	52-57 w/54 Nominal	30-35	85/15
	.040 (1.0)	120-600 w/175 Nominal (3.0-15.2 w/4.4 Nominal)	52-56 w/54 Nominal	25	90/10
	.040 (1.0)	120-600 w/175 Nominal (3.0-15.2 w/4.4 Nominal)	52-56 w/54 Nominal	25	85/15
	.045 (1.1)	140-500 w/175 Nominal (3.6-12.7 w/4.4 Nominal)	50-55 w/53 Nominal	25	90/10
	.045 (1.1)	140-500 w/175 Nominal (3.6-12.7 w/4.4 Nominal)	50-55 w/53 Nominal	25	85/15
Stainless Steel					
Process	Wire Size in (mm)	Wire Feed Speed IPM (mpm)	Arc Adjust/Trim	Arc Control	Shielding Gas
RMD Stainless Steel	.035 (0.9)	120-290 w/200 Nominal (3.0-7.4 w/5.1 Nominal)	47-51 w/50 Nominal	25	Tri-H
	.040 (1.0)	120-275 w/200 Nominal (3.0-7.4 w/5.1 Nominal)	48-52 w/50 Nominal	30	Tri-H
	.040 (1.0)	120-275 w/200 Nominal (3.0-7.4 w/5.1 Nominal)	48-52 w/50 Nominal	25	98/2 CO ₂
	.040 (1.0)	120-275 w/200 Nominal (3.0-7.4 w/5.1 Nominal)	48-52 w/50 Nominal	25	98/2 Ox
	.045 (1.1)	120-160 w/150 Nominal (3.0-4.1 w/3.8 Nominal)	48-52 w/50 Nominal	25	Tri-H

Table 3-6. PipePro 450 RFC Welding Programs (Continued)

Stainless Steel					
Process	Wire Size in (mm)	Wire Feed Speed IPM (mpm)	Arc Adjust/Trim	Arc Control	Shielding Gas
ProPulse Stainless Steel Using A Positioner (Rolling The Pipe)	.035 (0.9)	150-780 w/175 Nominal (3.8-19.8 w/4.4 Nominal)	53-57 w/55 Nominal	25	Tri-H
	.035 (0.9)	150-780 w/175 Nominal (3.8-19.8 w/4.4 Nominal)	52-57 w/56 Nominal	16	Tri-A
	.035 (0.9)	150-780 w/175 Nominal (3.8-19.8 w/4.4 Nominal)	48-54 w/53 Nominal	18	98/2 CO ₂
	.035 (0.9)	150-780 w/175 Nominal (3.8-19.8 w/4.4 Nominal)	48-52 w/51 Nominal	18	98/2 Ox
	.045 (1.1)	140-450 w/200 Nominal (3.6-11.4 w/5.1 Nominal)	52-55 w/55 Nominal	25	Tri-H
	.045 (1.1)	120-525 w/200 Nominal (3.0-13.3 w/5.1 Nominal)	53-57 w/55 Nominal	16	98/2 CO ₂
	.045 (1.1)	120-525 w/200 Nominal (3.0-13.3 w/5.1 Nominal)	53-57 w/55 Nominal	25	98/2 Ox
ProPulse Stainless Steel Welding In Position	.035 (0.9)	150-780 w/175 Nominal (3.8-19.8 w/4.4 Nominal)	53-57 w/55 Nominal	25	Tri-H
	.035 (0.9)	150-780 w/175 Nominal (3.8-19.8 w/4.4 Nominal)	52-56 w/54 Nominal	16	Tri-A
	.035 (0.9)	150-780 w/175 Nominal (3.8-19.8 w/4.4 Nominal)	48-52 w/50 Nominal	18	98/2 CO ₂
	.035 (0.9)	150-780 w/175 Nominal (3.8-19.8 w/4.4 Nominal)	46-50 w/48 Nominal	18	98/2 Ox
	.045 (1.1)	120-525 w/140 Nominal (3.0-13.3 w/3.6 Nominal)	53-57 w/55 Nominal	25	Tri-H
	.045 (1.1)	120-525 w/140 Nominal (3.0-13.3 w/3.6 Nominal)	50-55 w/53 Nominal	16	98/2 CO ₂
	.045 (1.1)	120-525 w/140 Nominal (3.0-13.3 w/3.6 Nominal)	50-55 w/53 Nominal	25	98/2 Ox
	.045 Inconel 625	150-500 w/300 Nominal (3.8-12.7 w/7.6 Nominal)	50-55 w/53 Nominal	25-30	Argon

Table 3-6. PipePro 450 RFC Welding Programs (Continued)

Flux Core					
Process	Wire Size in (mm)	Rolling Pipe/In Position Wire Feed Speed IPM (mpm)	Voltage	— —	Shielding Gas
Flux Core/GMAW	.045 (1.1)	175-780 w/200 Nominal (4.4-19.8 w/5.1 Nominal)*	24.5-32 w/24.5 Nominal	— —	75/25*
<p>Note: Arc Control is arc width and Arc Adjust/Trim is arc length. Wire feed speed and voltage are synergic for the RMD and ProPulse processes. Therefore, when adjusting wire feed speed, the voltage is automatically adjusted so it is not necessary to adjust Arc Adjust/Trim. These are only starting parameters, the operator must make final adjustments depending on material and conditions.</p>					
<p>*See wire manufacturer for recommended wire feed speed and gas mixture.</p>					

Table 3-7. PipeWorx 400 Welding Parameters

Steel				
Process	Wire Size in. (mm)	Wire Feed Speed IPM (mpm)	Arc Length	Shielding Gas
RMD Steel	.035 (0.9)	100-350 w/200 Nominal (2.5-8.9 w/5.1 Nominal)	+3.0 to -3.0 w/zero Nominal	C8 – C15
	.035 (0.9)	100-350 w/200 Nominal (2.5-8.9 w/5.1 Nominal)	+3.0 to -3.0 w/zero Nominal	C20 – C25
	.035 (0.9)	100-250 w/200 Nominal (2.5-6.4 w/5.1 Nominal)	+3.0 to -3.0 w/zero Nominal	CO ₂
	.045 (1.1)	100-250 w/150 Nominal (2.5-6.4 w/3.8 Nominal)	+3.0 to -3.0 w/zero Nominal	C8 – C15
	.045 (1.1)	100-250 w/150 Nominal (2.5-6.4 w/3.8 Nominal)	+3.0 to -3.0 w/zero Nominal	C20 – C25
	.045 (1.1)	100-200 w/150 Nominal (2.5-5.1 w/3.8 Nominal)	+3.0 to -3.0 w/zero Nominal	CO ₂
ProPulse Steel Using A Positioner 1G (Rolling The Pipe)	.035 (0.9)	120-780 w/250 Nominal (3.0-19.8 w/6.4 Nominal)	+3.0 to -3.0 w/zero Nominal	C8 – C15
	.045 (1.1)	140-500 w/250 Nominal (3.6-12.7 w/6.4 Nominal)	+3.0 to -3.0 w/zero Nominal	C8 – C15
ProPulse Steel Welding In Position 5G	.035 (0.9)	120-780 w/200 Nominal (3.0-19.8 w/5.1 Nominal)	+3.0 to -3.0 w/zero Nominal	C8 – C15
	.045 (1.1)	140-500 w/175 Nominal (3.6-12.7 w/4.4 Nominal)	+3.0 to -3.0 w/zero Nominal	C8 – C15

Table 3-7. PipeWorx 400 Welding Parameters (Continued)

Stainless Steel				
Process	Wire Size in. (mm)	Wire Feed Speed IPM (mpm)	Arc Length	Shielding Gas
RMD Stainless Steel	.035 (0.9)	120-350 w/200 Nominal (3.0-8.9 w/5.1 Nominal)	+3.0 to -3.0 w/zero Nominal	C2
	.035 (0.9)	120-350 w/200 Nominal (3.0-8.9 w/5.1 Nominal)	+3.0 to -3.0 w/zero Nominal	98/2 Ox
	.035 (0.9)	120-350 w/200 Nominal (3.0-8.9 w/5.1 Nominal)	+3.0 to -3.0 w/zero Nominal	Tri-H
	.035 (0.9)	120-350 w/200 Nominal (3.0-8.9 w/5.1 Nominal)	+3.0 to -3.0 w/zero Nominal	Tri-A
	.045 (1.1)	120-250 w/150 Nominal (3.0-6.4 w/3.8 Nominal)	+3.0 to -3.0 w/zero Nominal	C2
	.045 (1.1)	120-250 w/150 Nominal (3.0-6.4 w/3.8 Nominal)	+3.0 to -3.0 w/zero Nominal	98/2 Ox
	.045 (1.1)	120-250 w/150 Nominal (3.0-6.4 w/3.8 Nominal)	+3.0 to -3.0 w/zero Nominal	Tri-H
	.045 (1.1)	120-250 w/150 Nominal (3.0-6.4 w/3.8 Nominal)	+3.0 to -3.0 w/zero Nominal	Tri-A

Table 3-7. PipeWorx 400 Welding Parameters (Continued)

Stainless Steel				
Process	Wire Size in. (mm)	Wire Feed Speed IPM (mpm)	Arc Length	Shielding Gas
ProPulse Stainless Steel Using A Positioner 1G (Rolling The Pipe)	.035 (0.9)	150-780 w/250 Nominal (3.8-19.8 w/6.4 Nominal)	+3.0 to -3.0 w/zero Nominal	C2
	.035 (0.9)	150-780 w/250 Nominal (3.8-19.8 w/6.4 Nominal)	+3.0 to -3.0 w/zero Nominal	98/2 Ox
	.035 (0.9)	225-600 w/250 Nominal (5.7-15.2 w/6.4 Nominal)	+3.0 to -3.0 w/zero Nominal	Tri-H
	.035 (0.9)	150-780 w/250 Nominal (3.8-19.8 w/6.4 Nominal)	+3.0 to -3.0 w/zero Nominal	Tri-A
	.045 (1.1)	120-780 w/200 Nominal (3.0-19.8 w/5.1 Nominal)	+3.0 to -3.0 w/zero Nominal	C2
	.045 (1.1)	120-780 w/200 Nominal (3.0-19.8 w/5.1 Nominal)	+3.0 to -3.0 w/zero Nominal	98/2 Ox
	.045 (1.1)	140-780 w/200 Nominal (3.6-19.8 w/5.1 Nominal)	+3.0 to -3.0 w/zero Nominal	Tri-H
	.045 (1.1)	120-780 w/200 Nominal (3.0-19.8 w/5.1 Nominal)	+3.0 to -3.0 w/zero Nominal	Tri-A
ProPulse Stainless Steel Welding In Position 5G	.035 (0.9)	150-780 w/175 Nominal (3.8-19.8 w/4.4 Nominal)	+3.0 to -3.0 w/zero Nominal	C2
	.035 (0.9)	150-780 w/175 Nominal (3.8-19.8 w/4.4 Nominal)	+3.0 to -3.0 w/zero Nominal	98/2 Ox
	.035 (0.9)	150-780 w/175 Nominal (3.8-19.8 w/4.4 Nominal)	+3.0 to -3.0 w/zero Nominal	Tri-H
	.035 (0.9)	150-780 w/175 Nominal (3.8-19.8 w/4.4 Nominal)	+3.0 to -3.0 w/zero Nominal	Tri-A
	.045 (1.1)	120-525 w/140 Nominal (3.0-13.3 w/3.6 Nominal)	+3.0 to -3.0 w/zero Nominal	C2
	.045 (1.1)	120-525 w/140 Nominal (3.0-13.3 w/3.6 Nominal)	+3.0 to -3.0 w/zero Nominal	98/2 Ox
	.045 (1.1)	120-525 w/140 Nominal (3.0-13.3 w/3.6 Nominal)	+3.0 to -3.0 w/zero Nominal	Tri-H
	.045 (1.1)	120-525 w/140 Nominal (3.0-13.3 w/3.6 Nominal)	+3.0 to -3.0 w/zero Nominal	Tri-A

Table 3-7. PipeWorx 400 Welding Parameters (Continued)

Flux Core				
Process	Wire Size in. (mm)	Rolling Pipe/In Position Wire Feed Speed IPM (mpm)	Voltage	Shielding Gas
Flux Core/GMAW	Not Dependent	175-780 w/200 Nominal (4.4-19.8 w/5.1 Nominal)*	24.5-32 w/24.5 Nominal	Not Dependent
<p>Note: Arc Length – Length of arc from end of wire to weld puddle. Wire feed speed and voltage are synergic for the RMD and ProPulse processes. This means when adjusting wire feed speed, the voltage is automatically adjusted so it is not necessary to adjust the Arc Length.</p>				
<p>*See wire manufacturer for recommended wire feed speed and gas mixture.</p>				

B. Root Pass

The first weld pass is referred to as the root pass and is used to fill the gap between two sections of pipe. When using the GMAW process, the root pass is usually with an open root weld (no backing ring). Generally, a manual weld root pass is continuous all the way around and through the tack welds.

C. Hot Pass

The hot pass is usually a single weld that joins the root weld and both groove faces together. A split hot pass is generally an acceptable procedure for 2G welding and when the root opening is larger than normal.

D. Fill Pass

The fill pass should nearly fill the groove. If a bead sequence is necessary, an alternating pattern should be used from face to face of the joint. The location of each bead should have an adequate, uniform lap for each subsequent weld bead. If a narrow cavity should develop between weld beads or between the face of the joint and the weld bead it may result in a lack of fusion or contamination (slag). If possible, grind the area to eliminate the cavity and improve the lap weld before making the next weld.

E. Cap Pass

The cap weld should completely fill the top of the joint with the least amount of excessive build-up beyond the top surface of the pipe. Grinding may be necessary to improve the weld bead shape and remove any contamination before making the final cap pass.

3-12. Troubleshooting Guide

A. Process Issues

Trouble	Possible Causes	Remedy
Undercutting	Travel speed too high	Slow down travel speed
	Welding voltage too high	Decrease arc length, trim or voltage
	Dwell time not long enough	Pause longer while weaving
	Gun angle	Maintain 10 to 15 degree drag angle in RMD and 5 to 10 degree angle in pulse
Porosity	Inadequate shielding gas coverage	Check flowmeter for 35 to 50 SCFH
	Gas in contaminated/leaky connections	Check fittings, hoses and shielding gas connections
	Electrode contamination	Replace electrode
	Workpiece contamination	Remove paint, mill scale, rust, oil, and oxide
	Arc Voltage too high	Decrease arc length, trim or voltage
	Excessive contact tube to work distance	3/8 to 5/8 in. (10 to 16 mm) stick-out for RMD or pulse 3/4 to 1 in (19 to 25 mm) stick-out for FCAW
Incomplete fusion	Weld zone surfaces not free of film or excessive oxide	Grind or sand to clean off surface
	Insufficient heat input	Increase wire feed speed
	Too large of a weld puddle	Increase travel speed or decrease wire feed speed
	Improper welding technique	Re-evaluate welding method for proper technique
	Improper joint preparation	Increase joint angle
	Excessive travel speed	Decrease travel speed or increase wire feed speed
Humping and crowning	Excessive travel speed	Slow down travel speed or weave electrode
unmelted electrode on root side ("whiskers")	Improper welding technique	Focus electrode back further on weld puddle
Spatter	Long arc length	Shorten arc length or decrease voltage
	Bad shielding gas	Replace shielding gas
	Welding in globular transfer range (Argon gas)	Decrease voltage
Excessive melt through	Excessive heat input	Reduce wire feed speed
	Improper joint penetration	Shorten root opening
Other issues	Unable to resolve problem	Contact factory pipe welding products service (920-735-4001)

B. Parameter Issues

Change Required	Arc Voltage	Welding Current	Travel Speed
Deeper penetration		Increase	
Shallower penetration		Decrease	
Larger bead		Increase	Decrease
Smaller bead		Decrease	Increase
Higher, narrower bead	Decrease		
Flatter, wider bead	Increase		
Faster deposition		Increase	
Slower deposition		Decrease	

Miller Electric Mfg. Co.

An Illinois Tool Works Company
1635 West Spencer Street
Appleton, WI 54914 USA

International Headquarters—USA

USA Phone: 920-735-4505 Auto-Attended
USA & Canada FAX: 920-735-4134
International FAX: 920-735-4125

For International Locations Visit
www.MillerWelds.com

