

Fundamentals of

# MATHEMATICS

FOR JEE MAIN AND ADVANCED

# TRIGONOMETRY

Sanjay Mishra

**Fundamentals of Mathematics**

# **Trigonometry**

**Sanjay Mishra**

*B. Tech (IIT-Varanasi)*

**PEARSON**

Delhi • Chennai

**Copyright © 2015 Pearson India Education Services Pvt. Ltd**

Published by Pearson India Education Services Pvt. Ltd, CIN: U72200TN2005PTC057128, formerly known as TutorVista Global Pvt. Ltd, licensee of Pearson Education in South Asia

No part of this eBook may be used or reproduced in any manner whatsoever without the publisher's prior written consent.

This eBook may or may not include all assets that were part of the print version. The publisher reserves the right to remove any material in this eBook at any time.

ISBN: 978-93-325-3783-5

eISBN: 978-93-325-4183-2

Head Office: A-8 (A), 7th Floor, Knowledge Boulevard, Sector 62, Noida 201 309, Uttar Pradesh, India.

Registered Office: Module G4, Ground Floor, Elnet Software City, TS-140, Block 2 & 9 R

Salai, Taramani, Chennai 600 113, Tamil Nadu, India.

Fax: 080-30461003, Phone: 080-30461060

www.pearson.co.in, Email: [companysecretary.india@pearson.co](mailto:companysecretary.india@pearson.co)

# Contents

*Preface*      *vii*

*Acknowledgements*      *viii*

**Chapter 1    Trigonometric Ratios and Identities**      **1.1 – 1.140**

Introduction    1.1

Basic Concepts    1.1

- *Angles and Measurements*    • *Polygon and Its Properties*

Quadrants and Its Sign Conventions    1.6

Sign Convention of Angle    1.6

- *Domain and Range of Function*

Periodicity and Periodic Functions    1.9

- *Properties of eriodicity*

Even Function    1.12

- *Properties of Even Function*

Odd Function    1.12

Trigonometric Ratios and Their Properties    1.15

- *Sign of Trigonometric Ratios*

Trigonometric Identities    1.16

- *Pythagorian Identities*

Trigonometric Ratios of Some Specific Angles    1.17

- *Trigonometric Ratios of 45°*    • *Trigonometric Ratios of 30° and 60°*
- *Trigonometric Ratios of 0° and 90°*    • *Sin x and Cosec x*    • *Cos x and Sec x*
- *Tan x and Cot x*

Trigonometric Ratios for Allied Angles    1.23

Trigonometric Ratios of  $(\pi \pm \theta)$  in Terms of  $\theta$     1.24

Inter-conversion of Trigonometric Ratios    1.27

Formulae on Trigonometric Ratios of Compound Angles    1.30

- *Intercept Application of Submultiple of an Angle*    • *Sum and Difference of Tangent and Cotangents*    • *Conversion Formulae (Product into Sum)*

Conversion Formulae (Sum into Product)    1.40

Trigonometric Ratios of the Sum of Three or More Angles    1.41

Conditional Identities    1.44

Application of Trigonometry for Eliminating Variables	1.46
Maximum and Minimum Values of Trigonometric Functions	1.49
Application of Theory of Equation	1.53
• <i>Applications Based on Quadratic Equation</i>	
Application Using Transformation of Equations	1.54
Proving Trigonometric Inequalities	1.55
• <i>Jenson's Functional Equation and Inequality and Its Applications</i>	
• <i>Discussions</i>	
Summation of Series Containing Sine and Cosine of Angles Forming an A.P.	
• <i>Sine of Angle Forming an AP</i>	1.58
Cosine of Angle Forming an A.P.	1.59
Application of Complex Numbers for Sum of Trigonometric Series	1.60
Series Containing Product of Cosine of the Angles Forming a G.P.	1.62
<b>Multiple-choice Questions</b>	<b>1.63</b>
Objective Solved Examples	1.63
Subjective Solved Examples	1.68
Tutorial Exercises	1.85
<i>Answer Keys</i>	1.95
<i>Hints and Solutions</i>	1.96
<b>Chapter 2 Trigonometric Equations</b>	<b>2.1 – 2.108</b>
Introduction	2.1
Trigonometric Equations	2.1
• <i>Solution of Trigonometric Equations</i>	
• <i>Particular Solution</i>	
• <i>Principal Solution</i>	
• <i>General Solution</i>	
• <i>General Solution of Equation <math>\text{Sin}\theta = k</math></i>	
• <i>General Solution of Equation <math>\text{Tan } \theta = k</math></i>	
Equivalent Equations	2.13
Important Points to Remember	2.13
• <i>Caution: 1</i>	
• <i>Caution: 2</i>	
• <i>Caution: 3 (Domain of Equation)</i>	
• <i>Caution: 4 (Root Loss in an Equation)</i>	
• <i>Caution: 5 (Extraneous Roots)</i>	
Sources of Extraneous Root and Loss of Root	2.17
Trigonometric Equation of Some Special Forms	2.20
• <i>Equation of Form: <math>(a \text{ Cos } x + b \text{ Sin } x = c)</math></i>	
• <i>Equation of the Form: <math>a_0 \text{ Sin}^n x + a_1 \text{ Sin}^{n-1} x \text{ Cos } x + a_2 \text{ Sin}^{n-2} x \text{ Cos}^2 x + \dots + a_n \text{ Cos}^n x = 0</math></i>	
• <i>A Trigonometric Equation of the Form: <math>\mathbb{R}(\text{Sin } kx, \text{ Cos } nx, \text{ Tan } mx, \text{ Cot } lx) = 0</math></i>	
• <i>Equation of the Form: <math>\mathbb{R}(\text{Sin } x + \text{Cos } x, \text{ Sin } x \cdot \text{Cos } x) = 0</math></i>	
• <i>Equation Involving Higher Even Power of Sin x and Cos x</i>	
Solving Simultaneous Equations	2.28
• <i>Equations with Only One Variable</i>	
• <i>Equations with Two or More Variables</i>	
Problems Based on Extreme Values of Sin x and Cos x	2.33
• <i>Type I: Trigonometric Equations Involving Single Variable</i>	
• <i>Type II: Trigonometric Equations Involving More Than One Variables</i>	

Transcendental Equations	2.35
Graphical Solutions of Equations	2.38
Solving Inequalities	2.41
• <i>Review of Some Important Trigonometric Values</i>	
<b>Multiple-choice Questions</b>	<b>2.46</b>
Subjective Solved Examples	2.46
Objective Solved Examples	2.55
Tutorial Exercises	2.64
<i>Answer Keys</i>	2.72
<i>Hints and Solutions</i>	2.73
<b>Chapter 3 Properties and Solution of Triangle</b>	<b>3.1 – 3.126</b>
Introduction	3.1
Properties of Triangle ( $\Delta$ )	3.1
Solution of Triangle ( $\Delta$ )	3.1
Sine Formula	3.1
• <i>Applications of Sine Formula</i>	
Cosine Formula	3.3
• <i>Applications of Cosine Formula</i>	
Projection Formula	3.6
Napier's Analogy (Tangent Rule)	3.9
To Find the Sine, Cosine and Tangent of the Half-angles in Terms of the Sides	3.11
Area of Triangle $ABC$	3.12
' $m$ - $n$ ' Theorem (Cotangent Theorem)	3.16
Solution of Triangle	3.21
Geometrical Discussion	3.22
Centroid of Triangle and Length of Median	3.28
• <i>Length of Medians</i> • <i>The Angles that the Median Makes with Sides</i>	
Circumcircle and Circumcentre of Triangle	3.29
Incircle of a Triangle	3.29
Escribed Circles	3.30
Orthocentre, Pedal Triangle and Its Properties	3.35
Circumcircle of Pedal Triangle (Nine Point Circle)	3.36
• <i>Properties of Nine Point Circle</i>	
The Ex-central Triangle	3.37
The Centroid Lies on the Line Joining the Circumcentre to the Orthocentre	3.38
The Length of Angle Bisector and the Angle That the Bisector Makes with the Sides	3.41
The Perimeter and Area of a Regular Polygon of $n$ -sides Inscribed in a Circle	3.42
The Perimeter and Area of Regular Polygon of $n$ -sides Circumscribed About a Given Circle	3.42
The Radii of the Inscribed and Circumscribing Circles of a Regular Polygon	3.42

<b>Multiple-choice Questions</b>	<b>3.52</b>
Objective Solved Examples	3.52
Subjective Solved Examples	3.61
Tutorial Exercises	3.71
<i>Answer Keys</i>	3.80
<i>Hints and Solutions</i>	3.81
<b>Chapter 4 Inverse Trigonometric Functions</b>	<b>4.1 – 4.138</b>
Introduction	4.1
Inverse Function	4.1
Inverse Trigonometric Function	4.2
Graphs of Inverse Circular Functions and Their Domain and Range	4.2
Compositions of Trigonometric Functions and Their Inverse Functions	4.17
Inverse Circular Functions of Their Corresponding Trigonometric Functions in Principal Domain	4.18
Inverse Circular Functions of Their Corresponding Trigonometric Functions in Complete Domain	4.19
Inverse Trigonometric Functions of Negative Inputs	4.28
Inverse Trigonometric Functions of Reciprocal Inputs	4.28
Inter Conversion of Inverse Trigonometric Functions	4.29
Three Important Identities of Inverse trigonometric Functions	4.37
Multiples of Inverse Trigonometric Functions	4.39
Sum and Difference of Inverse Trigonometric Functions	4.50
<b>Multiple-choice Questions</b>	<b>4.64</b>
Objective Solved Examples	4.64
Subjective Solved Examples	4.71
Tutorial Exercises	4.87
<i>Answer Keys</i>	4.96
<i>Hints and Solutions</i>	4.97

# Preface

---

The word 'Trigonometry' (*Tri + Gono + Metry*) means measurement of triangle and is derived from the Greek word 'Goni,' which means an 'Angle'. This branch of mathematics was nurtured on the Indian soil for a number of centuries by Hindu Scholars Arya Bhatt (5th century AD), Varhamihira (6th century AD), Brahma Gupta (7th century AD), Bhaskara (12th century AD), and later it was passed on to the West through the Arabs. After 16th century AD, it evolved there in the form of Modern Trigonometry out of the monumental works of great European mathematicians like Vieta (16th century AD) and Leonahrd Euler (18th century AD).

In my school days, I was taught Trigonometry by conventional approach of cramming identities and formulae. Therefore, I developed a strong phobia of this subject, but later on, when I tried to understand the need and origin of trigonometric functions and their properties, I found that this branch of mathematics is equally interesting and challenging and can be learnt through conceptual approach to minimize cramming of results.

In my yesteryears, during my high school days, as an IIT-JEE aspirant, and later as a tutor of Mathematics for past fifteen years, I always felt the need of a comprehensive text book on Trigonometry that deals with the subject matter conceptually.

This book has been written with the objectives of providing a text book as well as an exercise book, focussing on problem solving. I feel this will not only fulfil the need of beginners, pre-college students (Students of Standard XI and XII), but also meet the requirements of advance level students who are preparing for various entrance examinations like IIT-JEE, AIEEEE, BIT-SAT, and other state engineering entrance examinations. This book, *Trigonometry*, develops a deep insight into topics: Trigonometric Functions, Trigonometric Equations and Identities, Inverse Trigonometric Function and Properties, and Solutions of Triangles. The well arranged content list will help students as well as teachers to access conveniently the chapters and sub topics of their interest. Each chapter is divided into several topics; each topic contains its theory and sometimes subtopics with sufficient number of worked out illustrative problems. Students can develop applicative ability of the concepts learned. This is followed by a textual exercise of both objective and subjective type problems, per the requirements. At the end of the theory of each chapter, a large set of solved examples of both objective and subjective type is given. This will involve application of all the concepts learnt in the chapter so that students can develop mastery over the chapter. The tutorial exercise given at the end contains a large number of multiple choice problems with single and multiple correct options, comprehension passages, column matching problems, numerical integer type questions to facilitate the students to do a thorough revision of the entire chapter and to raise their level of understanding of the topics. For teachers, this text both will be quite helpful as it will provide a set of well graded problems, arranged topic and subtopic wise, that can be used as home assignments to be given to their students.

All suggestions for improvement are welcome and shall be gratefully acknowledged.

---Sanjay Mishra



# Acknowledgements

---

I am really grateful to Pearson Education for keeping faith in me and for providing me with an opportunity to transform my yearning, my years of experience in teaching and my knowledge into the present comprehensive text book: *Fundamentals of Mathematics—Trigonometry*. I would like to thank all my friends and teachers, for their valuable criticism, support and advice that was really helpful to carve out this work. I am pleased to award special acknowledgements to all my pupils. During my interactions with my students, I have got much of the inspiration for writing this textbook. I believe that by interacting with them, I have learnt much more than I could have ever taught them. I wish to thank my parents and all my family members, for their patience and support in bringing out this book and donating their valuable share of time for such a cause. I extend my special thanks to Rakesh Gupta, Aditya Jindal, Sanket Sinha and other team members at MIIT Edu. Services Pvt. Ltd, for their hard work and dedication in completing this task.

---Sanjay Mishra

# Trigonometric Ratios and Identities

# 1 CHAPTER

## INTRODUCTION

In previous classes, you must have read the Pythagoras theorem in Geometry that, in a right angled triangle the sum of square of two sides (perpendicular and base) is equal to the square of the biggest side (hypotenuse). This theorem was very widely used for ages in various applications e.g., laying down the boundaries of the field at right angles or designing right angular crossings of roads etc.

The above theorem is true for all right angled triangles whatever be the lengths of the sides. Such an equality relationship is called an Identity.

The word 'Trigonometry' means the measurement of triangles. It is a word derived from *Gonia*, a Greek word, means an angle. This branch of mathematics was nurtured on Indian soil for a number of centuries by Hindu scholars like Aryabhata (5th Cen. AD), Varahamihira (6th Cen. AD), Brahmagupta (7th Cen. AD) and Bhaskara (12th Cen. AD) but later it passed on to the west through the Arabs. After the 16th century modern trigonometry took shape out of the works of European mathematicians like Vieta (16th Cen. AD) and Euler (18th Cen. AD) and many other eminent scholars.

A triangle has 6 basic components; 3 sides and three angles. If you take a triangle and increase its one side, then you will have to increase either some other side or some angle. It means that the three sides and angles are mutually dependent or there is some relationship between them. In this chapter, we shall examine these relationships. Some of these relationships are always true and hence we call them trigonometric identities. We shall learn these identities and also learn their various applications in various streams of mathematics and physics.

The contents of this chapter form elementary tools of a scientific worker. We should not only know the shapes

and size of these tools but we should also know how these tools were made i.e., we should be clear how these identities are derived. In this process, we will also learn how to apply these mathematical tools to solve various problems in mathematics and other branches of science.

## BASIC CONCEPTS

Suppose a student is looking at the top of the Eiffel Tower, a right triangle can be imagined to be made, as shown in the figure. Can the student find out the height of the Eiffel Tower, without actually measuring it?

In all situation like the one given above, the distance or the height can be found by using some mathematical techniques which comes under a branch of mathematics called trigonometry.

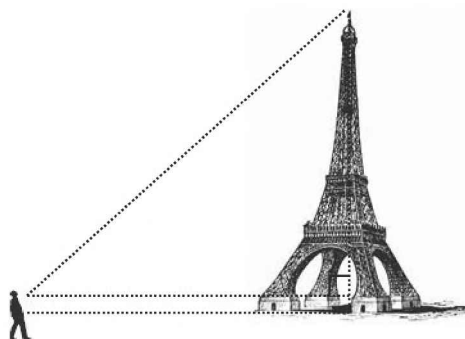

FIGURE 1.1

The word '**Trigonometry**' is derived from two Greek words:

- (i) Trigon and
- (ii) metron, the word trigon means a triangle and the word metron means a measure. Hence trigonometry means science of measuring triangles. Thus this is a

## 1.2 ➤ Trigonometry

branch of mathematics which deals with the study of measurement of triangle and its component and their various relations.

### Angles and Measurements

A physical quantity which defines the amount of inclination between two straight lines is called as angle between those two lines. S.I. units of its measurement is called radian. Being ratios of two lengths, it is a dimensionless quantity.

There are three systems used for the measurement of angles.

1. Sexagesimal system or English system (degree system)
2. Centesimal system or French system (grade system)
3. Circular system of measurement (radian system)

#### Sexagesimal or English system (degree)

Here a right angle is divided into 90 equal parts known as degrees. Each degree is divided into 60 equal parts called

minutes and each minute is further divided into 60 equal parts called seconds.

$$\therefore 60 \text{ seconds or } (60'') = 1 \text{ minute } (1')$$

$$60 \text{ minutes or } (60') = 1 \text{ degree } (1^\circ)$$

$$90 \text{ degree or } (90^\circ) = 1 \text{ right angle.}$$

#### Centesimal system or French system (grade)

Here a right angle is divided into 100 equal parts, called grades and each grade is divided into 100 equal parts, called minute (') and each minute is further divided into 100 equal parts called seconds (").

$$\therefore 100 \text{ seconds (or } 100'') = 1 \text{ minute } (1')$$

$$100 \text{ minutes (or } 100') = 1 \text{ grade } (1^g)$$

$$100 \text{ grades (or } 100^g) = 1 \text{ right angle.}$$

**ILLUSTRATION 1:** If  $x$  and  $y$  respectively denote the number of sexagesimal and centesimal seconds in any angle then show that  $250x = 81y$ .

**SOLUTION:** We know, in sexagesimal system: 60 seconds = 1 minute, 60 minutes = 1 degree and 90 degrees = 1 right angle.

Expressing the angle into right angles using both systems, we have

$$\therefore x \text{ seconds} = \frac{x}{60 \times 60 \times 90} \text{ right angle}$$

$$\text{and in the centesimal system: } y \text{ seconds} = \frac{y}{100 \times 100 \times 100} \text{ right angle}$$

$$\therefore \frac{x}{60 \times 60 \times 90} = \frac{y}{100 \times 100 \times 100} \Rightarrow 250x = 81y$$

**ILLUSTRATION 2:** The angles of a triangle are in A.P. and the number of grades in the least is to the number of radians in the greatest is 40:  $\pi$ , find the angle in degrees.

**SOLUTION:** Let the angles be  $(x - y)^\circ$ ,  $x^\circ$  and  $(x + y)^\circ$

Since the sum of the three angles of a triangle is  $180^\circ$ , we have

$$180 = x - y + x + x + y = 3x \Rightarrow x = 60$$

The required angles are therefore  $(60 - y)^\circ$ ,  $60^\circ$  and  $(60 + y)^\circ$

$$\text{Now } (60 - y)^\circ = \frac{10}{9} \times (60 - y)^g \text{ and } (60 + y)^\circ = \frac{\pi}{180} \times (60 + y) \text{ radians}$$

$$\text{Therefore } \frac{10}{9}(60 - y) : \frac{\pi}{180}(60 + y) :: 40 : \pi \text{ (given)} \quad \therefore \left(\frac{200}{\pi}\right) \left(\frac{60 - y}{60 + y}\right) = \frac{40}{\pi}$$

$$\Rightarrow 5(60 - y) = 60 + y \Rightarrow y = 40^\circ$$

The angles are therefore  $20^\circ$ ,  $60^\circ$  and  $100^\circ$

**TEXTUAL EXERCISE-1 (SUBJECTIVE)**

- Find radian measures corresponding to following degree measures.
    - $240^\circ$
    - $56^\circ$
    - $125^\circ 30'$
  - Find degree measures corresponding to following radian measures.
    - $\left(\frac{5\pi}{3}\right)^c$
    - $\left(\frac{5\pi}{24}\right)^c$
    - $(2.64)^c$
- One angle of a triangle is  $2x/3$  grades and another is  $3x/2$  degrees, while the third is  $\frac{\pi x}{75}$  radians; express them all in degrees.
- The angles of a triangle are in A.P. and the number of degrees in the least is to be number of radians in the greatest is  $60:\pi$ , find the angles in degrees.
- Find the radians and degree of the angle between the hour and the minute hand of a clock at
  - half past three,
  - twenty minutes to six,
  - quarter past eleven
- The angles of triangle are in A.P. and the number of radians in the least angle to the number of degrees in the mean angle is 1:120. Find the angles in radians.

**Answer Keys**

- $\frac{4\pi}{3}$
    - $\frac{14\pi}{45}$
    - $\frac{251\pi}{360}$
  - $300^\circ$
    - $37^\circ 30'$
    - $151^\circ 12'$
- $24^\circ, 60^\circ$  and  $96^\circ$
- $30^\circ, 60^\circ, 90^\circ$
    - $\left(\frac{5\pi}{12}\right)^c = 75^\circ = \left(83\frac{1}{3}\right)^g$
    - $\left(\frac{7\pi}{18}\right)^c = 70^\circ = \left(77\frac{7}{9}\right)^g$
    - $\left(\frac{5\pi}{8}\right)^c = 112.5^\circ = (125)^g$
- $\frac{1}{2}, \frac{\pi}{3}$  and  $\frac{2\pi}{3} - \frac{1}{2}$  radians

**Circular measurement or radian measure**

In this system, a unit called 'Radian' has been defined for the measurement of angle and it follows from the fact that the ratio of circumference of a circle (other than a point circle) to its diameter is always constant for all circles. Hence if we take the length of arc of any circle to its radius, it will always bear a constant ratio. This gives rise to circular measurement of angles and the unit 'Radian' is defined as:

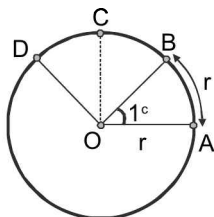
**FIGURE 1.2**

One radian ( $1^r$ ) =  $\frac{\text{arc length of magnitude } (r)}{\text{radius of circle } (r)}$

i.e., one radian corresponds to the angle subtended by arc of length  $r$  at the centre of the circle. Since the ratio is independent of the size of a circle it implies that 'radian' is constant quantity.

For a general angle,  $\angle AOD = \frac{\text{arc } AD}{r}$  radian ( $s$ )

**Definition of  $\pi$**  =  $\frac{\text{Perimeter of a circle}}{\text{Diameter}}$

Since the angles subtended at the centre of a circle are in proportion to their respective arc lengths.

$$\text{i.e., } \frac{\angle AOB}{\angle AOC} = \frac{\text{arc } AB}{\text{arc } AC} = \frac{r}{\pi r/2} = \frac{2}{\pi}$$

$$\text{But } \angle AOB = 1^r = \frac{2 \angle AOC}{\pi} = \frac{2 (\text{right angle})}{\pi} = \frac{180^\circ}{\pi}$$

## NOTES

1. Radian is the unit to measure angle and it does not mean that  $\pi$  stands for  $180^\circ$  ( $\pi$  is a real number) Where as  $\pi^\circ$  stands for  $180^\circ$ . Remember the relation  $\pi$  radian =  $180$  degrees =  $200$  grade.
2. The number of radians in an angle subtended by an arc of a circle at the centre is  $\frac{\text{arc}}{\text{radius}} \Rightarrow \theta = \frac{s}{r}$

## Polygon and Its Properties

**Polygon:** A closed figure surrounded by  $n$  straight lines is called polygon. It is classified in two ways:

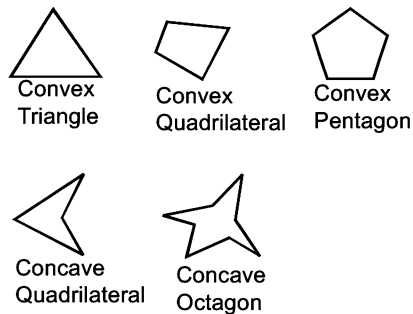

FIGURE 1.3

- (i) **Convex Polygon:** A polygon in which all the internal angles are smaller than  $180^\circ$ .
- (ii) **Concave Polygon:** A polygon in which at least one internal angle is larger than  $180^\circ$ .

## Properties

1. An angle is called **reflexive angle** if it is greater than or equal to  $180^\circ$  or  $\pi$  radians.
2. Sum of all internal angles of a convex polygon =  $(n-2)\pi^\circ = (n-2)180^\circ$ , irrespective of regular/irregular polygon.
3. Each internal angle of regular polygon of  $n$  sides =  $\frac{(n-2)\pi}{n}$

## NOTES

1. Perimeter of a circular sector of sectoral angle  $\theta^\circ = r(2 + \theta)$
2. Area of a circular sector of sectoral angle  $\theta^\circ = \frac{1}{2}r^2\theta$

POLYGON	NO. OF SIDES
Triangle	3
Quadrilateral	4
Pentagon	5
Hexagon	6
Heptagon	7
Octagon	8
Nonagon	9
Decagon	10
Hendecagon	11
Dodecagon	12
Triskaidecagon	13
Tetradecagon	14
Pentadecagon	15

**ILLUSTRATION 3:** If the three angles of a quadrilateral are  $60^\circ$ ,  $20^\circ$  and  $2\pi/3$ . Then find the fourth angle.

**SOLUTION:** First angle =  $60^\circ$ ; Second angle =  $20^\circ = 20 \times \frac{90}{100}$  degrees =  $18^\circ$

$$\text{Third angle} = \frac{2\pi}{3} \text{ radian} = \frac{2 \times 180}{3} = 120^\circ$$

$$\text{Fourth angle} = 360^\circ - (60^\circ + 18^\circ + 120^\circ) = 162^\circ$$

**ILLUSTRATION 4:** If the diameter of circular wheel of Konark Sun temple be 40m, and the length of a chord is 20 m. Find the length of minor arc corresponding to this chord.

**SOLUTION:** Let arc  $AB = s$ . It is given that  $OA = 20$  m and chord  $AB = 20$ m. Therefore,  $OAB$  is an equilateral triangle.

$$\text{Therefore } \angle AOB = 60^\circ = \left(60 \times \frac{\pi}{180}\right)^c = \left(\frac{\pi}{3}\right)^c, \text{ Since } \theta = \frac{\text{arc}}{\text{radius}} \Rightarrow \frac{\pi}{3} = \frac{s}{20} \Rightarrow s = \frac{20\pi}{3}$$

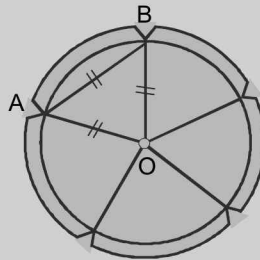

**FIGURE 1.4**

**ILLUSTRATION 5:** Express the interior angle of a regular decagon in three system of angular measurement.

**SOLUTION:** By geometry, sum of all interior angles of  $n$  sided polygon (convex) =  $(2n - 4) \frac{\pi}{2}$  radian

Let each interior angle of a regular decagon contains  $x$  radians, so that all the angles are together equal to  $10x$  radians ( $\because n = 10$ )

$$\text{now } 10x = [2(10) - 4] \frac{\pi}{2} \text{ radians} \Rightarrow x = \frac{4\pi}{5} \text{ radians} = \frac{4\pi^c}{5}$$

$$= 8/5 \text{ right angles} = (8/5) \times 90 \text{ degrees} = 144^\circ = (8/5) \times 100 \text{ grades} = 160^\circ$$

## TEXTUAL EXERCISE-2 (SUBJECTIVE)

- The number of sides in two regular polygons are as 5: 4, and the difference between their angles is  $9^\circ$ ; find the number of sides in the polygons.
- The angles of a quadrilateral are in A.P. and the greatest is double the least; express the least angle in radians.
- The wheel of a railway carriage is 90 cm in diameter and makes three revolutions in a second; how fast is the train going?
- The radius of a carriage wheel is 50 cm, and in  $1/9^{\text{th}}$  of a second turns through  $80^\circ$  about its centre, which is fixed; how many km does point on the rim of the wheel travel in one hour?
- Consider an equilateral triangle with sides = 4 m. Now, if a man runs around the triangle in such a way that he is always at a distance of 2 m from the sides of triangle then how much distance will he travel?

6. Consider a square of sides 4 m. Now, if a man runs at a distance of 2 m from the sides of the square. How much distance will he travel?

7. Consider a triangle with sides 3, 6, 8 m respectively. Now, if a man runs around the triangle in such a way that he is always at a distance of 2 m from the sides of triangle then how much distance will he travel?

### Answer Keys

1. 10 and 8      2.  $\pi/3$       3. 848.5cm/sec      4. 22.6 km approx.  
 5.  $12 + 4\pi$       6.  $16 + 4\pi$       7.  $17 + 4\pi$

### QUADRANTS AND ITS SIGN CONVENTIONS

Let  $XOX'$  and  $YOY'$  be two mutually perpendicular lines, then the plane gets divided into four parts called quadrants.  $XOX'$  is called  $X$ -axis and  $YOY'$  is called  $Y$ -axis. Right portion from  $O$  is called positive  $X$ -axis and left portion is called negative  $X$ -axis. Regions  $XOY$ ,  $X'OY$ ,  $X'OY'$ ,  $XOY'$  are called first, second, third and fourth quadrants respectively.

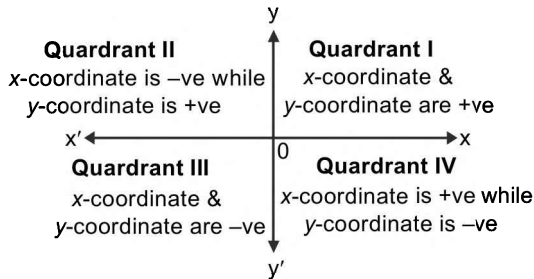

FIGURE 1.5

### SIGN CONVENTION OF ANGLE

We know that the direction opposite to that of the hands of a watch is called anti-clockwise direction, and the direction of the hands of a watch is called clockwise direction. Naturally few questions arise in your mind like:

- (i) Whether the angle  $\theta$  can be greater than  $2\pi$ ?
- (ii) Can the angle  $\theta$  be negative?

Answers can be obtained in following case analysis:

**Case I:** In one complete revolution in anti-clockwise direction,  $OP$ , with respect to  $OX$ , traces an angle of  $2\pi$  radians. So the angle made by  $OP$  with  $x$ -axis depends upon the number of revolution  $OP$  has taken w.r.t. origin  $O$ . e.g.,  $\angle XOY = \pi/2$ ,  $\angle XOY' = \pi$ ,  $\angle XOY' = 3\pi/2$ . If the angle is greater than  $2\pi$ , then case becomes interesting.

Let us suppose that the angle is larger than  $2\theta$  by some magnitude  $\theta$  (say). This can be represented by an equivalent

angle in the range  $0$  to  $2\pi$ . Reason is very simple, if one moves around a circle after every  $2\pi$  angle, he reaches the initial point. Thus this angle  $\theta$  can be represented in the form of  $(2n\pi + \theta)$ , where  $0 < \theta < 2\pi$  and  $n$  is any positive integer, representing number of revolutions.

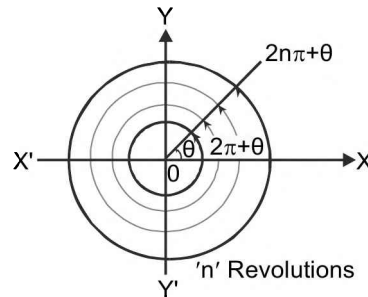

FIGURE 1.6

**Case II:** By convention we define an angle as positive if it is measured anti-clockwise with the positive  $X$ -axis. Thus any angle measured clockwise from the positive  $X$ -axis would be negative. This is analogous to the case of coordinates in the cartesian system, where we take distances to the right of origin as positive and distances towards left as negative.

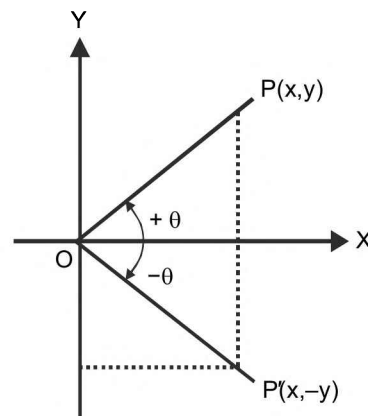

FIGURE 1.7

Let us take a right angled triangle  $ABC$  as shown in figure.

Here  $\angle CAB$  is an acute angle, Note the position of the side BC with respect to angle. It faces  $\angle A$ . We call BC, the side opposite to angle A. AC is the hypotenuse of the right triangle and the side AB is a part of  $\angle A$ . So, we call AB, side adjacent to angle A.

We now define certain ratios involving the sides of right triangle, and call them trigonometric ratios.

$$\text{Sine of } \angle A = \frac{\text{side opposite to angle } A}{\text{hypotenuse}} = \frac{BC}{AC}$$

$$\begin{aligned} \text{Cosine of } \angle A &= \frac{\text{side adjacent to angle } A}{\text{hypotenuse}} = \frac{AB}{AC} \\ &= \text{sine of } \angle C = \sin(90^\circ - \theta) \end{aligned}$$

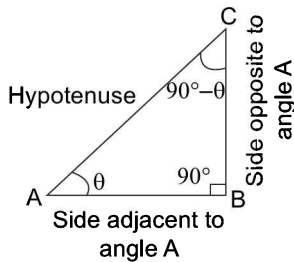

FIGURE 1.8

$$\begin{aligned} \text{Tangent of } \angle A &= \frac{\text{side opposite to angle } A}{\text{side adjacent to angle } A} = \frac{BC}{AB} \\ &= \text{cot of } \angle C = \cot(90^\circ - \theta) \end{aligned}$$

Cosecant of  $\angle A$

$$\begin{aligned} &= \frac{1}{\text{sine of } \angle A} = \frac{\text{hypotenuse}}{\text{side opposite to angle } A} \\ &= \frac{AC}{BC} = \text{Secant of } \angle C = \sec(90^\circ - \theta) = \text{cosec } \theta \end{aligned}$$

$$\text{secant of } \angle A = \frac{1}{\text{cosine of } \angle A}$$

$$= \frac{\text{hypotenuse}}{\text{side adjacent to angle } A} = \frac{AC}{AB}$$

$$= \text{cosecant of } \angle C = \text{cosec}(90^\circ - \theta)$$

cotangent of

$$\begin{aligned} \angle C &= \frac{1}{\text{tangent of } \angle A} = \frac{\text{side adjacent to angle } A}{\text{side opposite to angle } A} \\ &= \frac{AB}{BC} = \text{tan of } \angle C = \tan(90^\circ - \theta) \end{aligned}$$

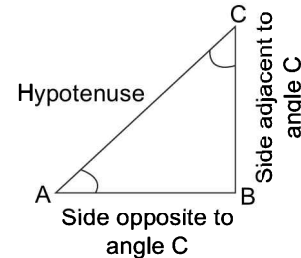

FIGURE 1.9

## NOTE

1. The ratios cosec A, sec A and cot A are respectively, the reciprocals of the ratios sin A, cos A and tan A

**ATM:** Some Person Had Curly Brown Hair Turn Permanently Black i.e.,  $S = P/H$ ;  $C = B/H$ ;  $T = P/B$  where S, C, T, P, B and H stands for Sine, Cosine, Tangent, Perpendicular, Base and Hypotenuse respectively.

2. Note that the symbol sin A is used as an abbreviation for 'the sine of the angle A'. sin A is not the product of 'sin' and A. Sin separated from A has no meaning. Similary for Cos A, Sec A, Tan A, Cosec A and Cot A.

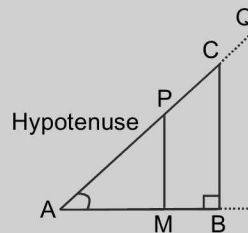

FIGURE 1.10

For the sake of convenience, we may write  $\sin^2 A$ ,  $\cos^2 A$ , etc. in place of  $(\sin^2 A)$ ,  $(\cos^2 A)$ , etc. respectively. But cosec A =  $(\sin A)^{-1} \neq \sin^{-1} A$  (it is called sine inverse A).  $\sin^{-1} A$  has a different meaning, which will be discussed in the chapters to come.



**ILLUSTRATION 6:** What will be the trigonometric ratios for negative angles?

**SOLUTION:** Now let us establish relation between trigonometrical ratio of positive angle and negative angle.

From the figure, it is clear that  $\sin \theta = \frac{y}{\sqrt{x^2 + y^2}}$  and

$$\sin(-\theta) = \frac{(-y)}{\sqrt{x^2 + y^2}} = -\sin \theta \Rightarrow \sin(-\theta) = -\sin \theta$$

Similarly, we obtain that,  $\cos \theta = \frac{x}{\sqrt{x^2 + y^2}}$

$$\text{and } \cos(-\theta) = \frac{x}{\sqrt{x^2 + y^2}} = \cos \theta \Rightarrow \cos(-\theta) = \cos \theta$$

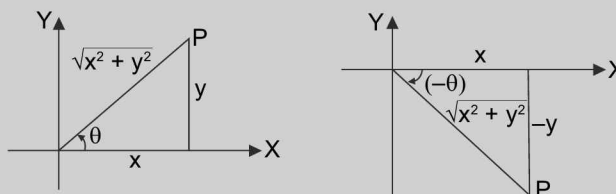

**FIGURE 1.11**

## NOTE

If the revolution is clockwise, then the angles measured are negative. An angle is said to be in that quadrant in which its ray lies. If ray  $\overline{OP}$  makes an angle  $\theta$  with positive X-axis, then we say that it has made an angle  $(2n\pi + \theta)$  where  $n \in \mathbb{Z}$  and represents  $|n|$  number of complete revolutions of  $OP$  around  $O$  (anticlockwise for  $n > 0$  and clockwise for  $n < 0$ ).

From, the figure, we can visualize that after every revolution or any  $n$  revolutions, the co-ordinates of the point  $P(x, y)$  ( $x$  and  $y$  are distances from origin or the initial point) remains same and therefore, the trigonometrical ratios in such cases will be unaltered. So the results are,

$$\sin(2n\pi + \theta) = \sin \theta, \cot(2n\pi + \theta) = \cot \theta$$

$$\cos(2n\pi + \theta) = \cos \theta, \sec(2n\pi + \theta) = \sec \theta$$

$$\tan(2n\pi + \theta) = \tan \theta, \operatorname{cosec}(2n\pi + \theta) = \operatorname{cosec} \theta; \forall n \in \mathbb{Z}$$

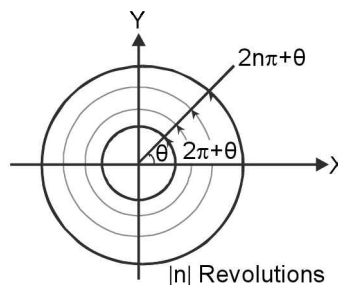

**FIGURE 1.12**

## NOTES

1. That is the reason why every trigonometric function of  $\theta$  is periodic with the period  $2\pi$ . But then, that does not mean that the fundamental period of every trigonometrical function is  $2\pi$ . (This will be discussed in the pages to come)

2. Since the hypotenuse is the greatest side in a right angled triangle,  $\sin \theta$  and  $\cos \theta$  can never be greater than unity and  $\operatorname{cosec} \theta$  and  $\sec \theta$  can never be less than unity.  
Hence  $|\sin \theta| \leq 1$ ,  $|\cos \theta| \leq 1$ ,  $|\operatorname{cosec} \theta| \geq 1$ ,  $|\sec \theta| \geq 1$ , while  $\tan \theta$  and  $\cot \theta$  may have any numerical value lying between  $-\infty$  to  $+\infty$ .

3. Students must remember the following results:

- |  |   |                                  |
|--|---|----------------------------------|
| (a) $-1 \leq \sin \theta \leq 1$                                     | (b) $-1 \leq \cos \theta \leq 1$                  | (c) $\tan \theta \in \mathbb{R}$ |
| (d) $\operatorname{cosec} \theta \in (-\infty, -1] \cup [1, \infty)$ | (e) $\sec \theta \geq 1$ or $\sec \theta \leq -1$ | (f) $\cot \theta \in \mathbb{R}$ |

## Domain and Range of Function

**Function** A function is defined as a relation in  $x$  which generates exactly one output for each value (input) of  $x$ . It is denoted by  $f(x)$  and read as  $f$  of  $x$  or function of  $x$ . e.g.,  $f(x) = 2x + 1$ ,  $f(x) = 2^x$ ,  $f(x) = x^2 \sin x$  etc. The relation  $y^2 = x$ ,  $y^2 = \sin x$  are not functions because they generate more than one output (values of  $y$ ) for one input. e.g., for  $y^2 = x$  at  $x = 1$  we get two values of  $y$ , (+1 and -1).

**Domain of function** Domain of a function  $f(x)$  is defined as set of independent variable  $x$  for which function is defined and takes a real and finite value (here we have considered only real valued functions). If a function is defined from set  $X$  to set  $Y$ , then set  $X$  is known as **domain** and set  $Y$  is known as **co-domain** of function. e.g.,  $y = \log_e x$

is defined for  $x > 0$ , therefore domain of  $y = \log_e x$  is  $(0, \infty)$  and  $y = \sin x$  is defined for all  $x$ , therefore domain of  $\sin x$  is  $\mathbb{R}$ . (i.e., set of real numbers). A subset of domain of function in which the function takes up its complete range of values exactly once is called **principal domain** of the function. Conventionally, it is selected nearest to the origin.

**Range of function** Range of the function  $f: X \rightarrow Y$  is the collection of all outputs corresponding to the real numbers in the domain of function i.e., the set of all  $f$ -images of elements of set  $X$  is known as the range of function  $f(x)$  and is denoted by  $R_f$ ;  $R_f = \{y: y \in Y \text{ and } y = f(x) \text{ for some } x \in X\}$ . Range is also called domain of variation and it is always a subset of codomain ( $Y$ ).

e.g., the range of  $\log(x)$  is set of real numbers while the range of  $\sqrt{x}$  is  $[0, \infty)$ .

### NOTE

Detailed explanation of Domain and Range is given in our book on Calculus.

## PERIODICITY AND PERIODIC FUNCTIONS

A function is known as periodic if it repeats its values after a constant interval of length  $T$ . In mathematical terms, a function  $f(x)$  is said to be a periodic function with period  $T$ , if there exists a non-zero real finite positive constant  $T$  (independent of  $x$ ) such that  $f(x + T) = f(x) \forall x \in D_f$

e.g.,  $\sin x = \sin(x + 2\pi) = \sin(x + 4\pi)$ . The least positive value of such  $T$ , if exists, is known as fundamental period of the given function  $f(x)$ .

e.g., The fundamental period of an analog clock is 12 hours and that of a digital clock 24 hours.

### Properties of periodicity

1. Constant function is a periodic function without any period. This happens because of the non-existence of the least positive real number  $T$  which is due to the continuity of real number system.
2. If  $f(x)$  has its period  $T$ , then  $f(ax + b)$  has its period  $\frac{T}{|a|}$ .
3. If  $f(x)$  has its period  $T_1$  and  $g(x)$  has its period  $T_2$ , then  $(af(x) + bg(x))$  has its period  $\leq LCM(T_1, T_2)$ . Moreover if  $f(x)$  and  $g(x)$  are basic trigonometric functions, then period of  $[af(x) + bg(x)] = L.C.M(T_1, T_2)$  provided  $f(x)$  and  $g(x)$  are not interconvertible and the  $LCM$  of their periods exists.

**ILLUSTRATION 7:** Examine whether  $\sin x$  is a periodic function or not. If so, find its period.

**SOLUTION:** Given  $f(x) = \sin x$ . Let us assume  $\sin x$  to be periodic.

So, it must have some positive value  $T$  independent of  $x$  such that  $f(x + T) = f(x)$

$$\Rightarrow \sin(x + T) = \sin x$$

$$\Rightarrow x + T = n\pi + (-1)^n x, \text{ where } n \in \mathbb{Z}$$

The positive values of  $T$  independent of  $x$  are given by  $n\pi$ , where  $n = 2, 4, 6, \dots$

According to the definition of fundamental period, it should be least. So here we have  $T = 2\pi$ . Thus it is proved that  $\sin x$  is periodic function having fundamental period (generally called period)  $2\pi$ .

**ILLUSTRATION 8:** Prove that  $\sin \sqrt{x}$  is not a periodic function.

**SOLUTION:** Let the positive real number  $T$  be such that  $f(x + T) = f(x)$

$$\Rightarrow \sin \sqrt{x+T} = \sin \sqrt{x}$$

$$\Rightarrow \sqrt{x+T} = n\pi + (-1)^n \sqrt{x}$$

This above relation does not give any positive value of  $T$  independent of  $x$  because it holds only when  $T = 0$

$\therefore f(x)$  is non-periodic function.

**ILLUSTRATION 9:** Find the period of  $\sin 4x \sin 3x$ .

**SOLUTION:**  $\sin 4x \sin 3x = (1/2) (2 \sin 4x \sin 3x)$

$$= \frac{1}{2} [\cos(4x - 3x) - \cos(4x + 3x)] = \frac{1}{2} (\cos x - \cos 7x)$$

$[\because 2 \sin A \sin B = \cos(A - B) - \cos(A + B)]$  (this will be discussed in the chapters to come)

Period of  $\cos x = 2\pi$

period of  $\cos 7x = 2\pi/7$

LCM of  $2\pi, 2\pi/7$  is  $2\pi$ .

Hence periodicity =  $2\pi$ .

**ILLUSTRATION 10:** Find the domain and range of  $f(x) = \frac{2 \sin x}{1 + \sin^2 x}$ .

**SOLUTION:** Domain: since  $D'$  can never be equal to zero and  $\sin x$  is defined  $\forall x \in \mathbb{R}$

$$y = \frac{2}{\left(\sin x + \frac{1}{\sin x}\right)} \text{ and domain} = \mathbb{R}$$

using  $AM \geq GM$ , we can say that  $\frac{1}{2} \left| \sin x + \frac{1}{\sin x} \right| \geq 1$

$$\text{and } \frac{2}{\left| \sin x + \frac{1}{\sin x} \right|} \leq 1 \Rightarrow -1 \leq \frac{2}{\left(\sin x + \frac{1}{\sin x}\right)} \leq 1 \text{ and hence range} = [-1, 1]$$

**TEXTUAL EXERCISE-3 (SUBJECTIVE)**

- Find period of  $f(x) = \sin \pi x + \cos x$
- Find the periodicity of the function  $f(x) = a \sin \lambda x + b \cos \lambda x$ .
- Given  $f(x) = \begin{cases} 1 & \text{if } x \in \mathbb{Q} \\ -1 & \text{if } x \in \mathbb{R} - \mathbb{Q} \end{cases}$ . Is  $f(x)$  periodic?  
Can you find the fundamental period of  $f(x)$ ?
- Find period of
  - $\sin x \cdot \sin 2x$
  - $\cot 2x \cdot \sec 3x$
  - $\cot \pi x \cdot \sec^2(3\pi x)$
  - $\cot^3 x \cdot \sec(3\pi x)$
  - $\frac{2 \sin^2 3x - 3 \tan 4x + 4 \cot 6x}{|\operatorname{cosec} 8x| - \sec^3 10x + \sqrt{\cot 12x}}$
  - $\frac{2 \sin^2 6x - 3 \tan(4x/3) + 4 \cos^2 6x}{|\operatorname{cosec} 8x| - \sec^3 \frac{16x}{3} + \sqrt{\cot \frac{12x}{5}}}$
- Find periods of
  - $f(x) = \sin(2\pi x + \pi/4) + 2 \sin(3\pi x + \pi/3)$
  - $f(x) = \cos^2 x + \sin^2 x$

- $f(x) = \cos^6 x + \sin^6 x$
  - $f(x) = \sin^2\left(2x + \frac{\pi}{3}\right) + \left|\tan\left(\pi x + \frac{\pi}{6}\right)\right|$
  - $f(x) = 2^{\cos x}$
- Find the range of
    - $f(x) = \sqrt{\cos x - 1}$
    - $f(x) = \frac{1}{\sqrt{1 - |\operatorname{cosec} x|}}$
  - Find the range of
    - $f(x) = \frac{1}{\sqrt{1 - \tan^2 x}}$
    - $f(x) = \sqrt{2 - \sec x}$
    - $f(x) = \sqrt{|\cot x| - 1}$
    - $f(x) = \tan\left(\frac{\pi}{2}[x]\right)$ , where  $[x]$  denotes the G.I.F.
    - $f(x) = \frac{1}{\sqrt{|\tan x| - \tan x}}$
    - $f(x) = \sqrt{(1 - \cos x)\sqrt{(1 - \cos x)\sqrt{(1 - \cos x)\dots\infty}}}$
    - $f(x) = \cos^2 x - 5 \cos x - 6$

8. Fill in the blanks in each case with the fundamental period.

$f(x)$	$f(x)$	$f^2(x)$	$f x $	$f^2 x $	$f 2x $	$f(x/3)$	$ f(x) $
$\sin x$	$2\pi$	—	Not periodic	$\pi$	—	$6\pi$	$\pi$
$\cos x$	—	$\pi$	—	—	$\pi$	—	—
$\tan x$	$\pi$	—	Not periodic	—	—	$3\pi$	—
$\cot x$	—	$\pi$	—	$\pi$	$\pi/2$	—	$\pi$
$\operatorname{Cosec} x$	—	—	—	—	—	—	—
$\sec x$	$2\pi$	—	$2\pi$	$\pi$	—	$6\pi$	$\pi$

**Answer Keys**

- not periodic
- $\frac{2\pi}{|\lambda|}$
- yes, no
- (a)  $2\pi$  (b)  $2\pi$  (c) 1 (d) not periodic (e)  $\pi$  (f)  $15\pi/2$
- (a) 2 (b) periodic but no fundamental period (c)  $\pi/2$  (d) not periodic (e)  $2\pi$
- (a) 0 (b)  $\phi$
- (a)  $[1, \infty)$  (b)  $[0, 1] \cup [\sqrt{3}, \infty)$  (c)  $[0, \infty)$  (d)  $\{0\}$  (e)  $(0, \infty)$  (f)  $[0, 2]$  (g)  $[-10, 0]$
- 8.

$f(x) \downarrow$	$f(x)$	$f^2(x)$	$f x $	$f^2 x $	$f 2x $	$f(x/3)$	$ f(x) $
$\sin x$	$2\pi$	$\pi$	Not periodic	$\pi$	Not periodic	$6\pi$	$\pi$
$\cos x$	$2\pi$	$\pi$	$2\pi$	$\pi$	$\pi$	$6\pi$	$\pi$
$\tan x$	$\pi$	$\pi$	Not periodic	$\pi$	Not periodic	$3\pi$	$\pi$
$\cot x$	$\pi$	$\pi$	Not periodic	$\pi$	Not periodic	$3\pi$	$\pi$
$\operatorname{Cosec} x$	$2\pi$	$\pi$	Not periodic	$\pi$	Not periodic	$6\pi$	$\pi$
$\sec x$	$2\pi$	$\pi$	$2\pi$	$\pi$	$\pi$	$6\pi$	$\pi$

## NOTES

- (i) Students are advised to relate this topic of periodicity with the graphs of trigonometrical functions.
- (ii) We can also find the periodicity of composite function like  $\cos(\sin x)$ ,  $\tan(\cos x)$ ,  $\sin(\cos x)$  etc., but that will be discussed in our book on Calculus.

### EVEN FUNCTION

A function  $f: \mathbb{R} \rightarrow \mathbb{R}$  is said to be an even function if  $f(-x) = f(x)$  for all  $x \in \mathbb{R}$ . i.e.,  $f(x) - f(-x) = 0$

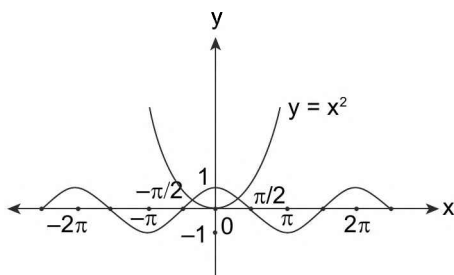

FIGURE 1.13

e.g.,  $f(x) = x^2 \forall x \in \mathbb{R}$ ,  $f(x) = \cos x \forall x \in \mathbb{R}$ ,  
 $f(x) = \sec x$ ,  $f(x) = x^{2n}$ ,  
 $f(x) = (\sin x)^{2n}$ , are the examples of even functions.

### Properties of Even Function

1. The product of two even functions is an even function.
2. The sum and difference of two even functions is even function.

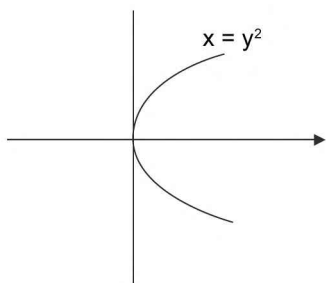

FIGURE 1.14

3. The division of two even function is even provided denominator is not equal to zero.
4. For real Domain; even functions are not one-one function.
5. Even function with respect to  $x$  is symmetrical about  $y$ -axis e.g.,  $y = x^2$
6. Even function with respect to  $y$  is symmetrical about  $x$ -axis e.g.,  $x = y^2$

### ODD FUNCTION

A function  $f: \mathbb{R} \rightarrow \mathbb{R}$  is said to be an odd function if  $f(-x) = -f(x)$  for all  $x \in \mathbb{R}$ . i.e.,  $f(x) + f(-x) = 0$ .  
 e.g.,  $f(x) = x^3$ ,  $f(x) = \sin x$ ,  $f(x) = \cot x$ ,  $f(x) = x^{2n+1}$ ,  $f(x) = (\tan x)^{2n+1}$  are the examples of odd functions.

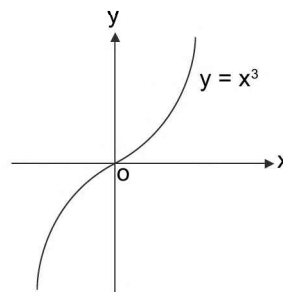

FIGURE 1.15

### Properties of odd function

1. Odd functions are always symmetrical about origin or they are symmetric in opposite quadrants.
2. The sum and difference of two odd functions is odd function.
3. The division/product of an even and an odd function is always an odd function provided  $D'$  is not equal to zero.

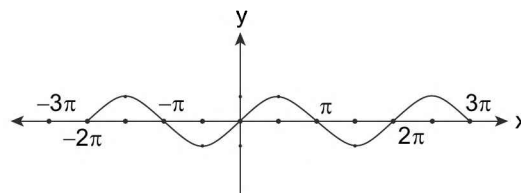

FIGURE 1.16

4. It is not essential that every function is even or odd. It is possible to have some functions which are neither even nor odd function.
5. The sum of even and odd function is neither even nor odd function.
6. The first derivative of an even function is an odd function and vice versa. e.g.,  $f(x) = x^4$ ,  $f'(x) = 4x^3$

7. Every odd continuous function passes through origin.  
[But the vice versa may not be true]
9. Every function can be expressed as the sum of an even and an odd function.

$$\text{e.g., } f(x) = \left( \frac{f(x) + f(-x)}{2} \right) + \left( \frac{f(x) - f(-x)}{2} \right)$$

$$\text{Let } h(x) = \left( \frac{f(x) + f(-x)}{2} \right) \text{ and}$$

$$g(x) = \left( \frac{f(x) - f(-x)}{2} \right).$$

It can now easily be shown that  $h(x)$  is even and  $g(x)$  is odd.

### NOTE

$f(x) = 0, \forall x \in \mathbb{R}$ ; is a function which can be considered an even function as well as an odd function.

### TEXTUAL EXERCISE-4 (SUBJECTIVE)

1. Check whether following functions are even or odd.

(a)  $x^3 - 2x^5$

(b)  $x \sin x$

(c)  $2^x + 2^{-x}$

(d)  $2^x - 2^{-x}$

(e)  $\frac{2x}{1+x^2}$

(f)  $\log\left(\frac{1-x}{1+x}\right)$

(g)  $\log(2x + \sqrt{4x^2 + 1})$

### Answer Keys

- (a) odd    (b) even    (c) even    (d) odd    (e) odd    (f) odd    (g) odd

### TEXTUAL EXERCISE-1 (OBJECTIVE)

1. How many times do the minute and hour hands of a clock coincide in a period of 12 h?  
(a) 12                      (b) 10  
(c) 22                      (d) 11
2. How many times do the hands of the watch coincide in a complete day?  
(a) 24 times              (b) 32 times  
(c) 48 times              (d) 22 times
3. How many times do the hands of the watch form a right angle during a complete day?  
(a) 48                      (b) 24  
(c) 22                      (d) 44
4. How many times are the minute hand and the hour hand are at right angles in a week?  
(a) 308                      (b) 336  
(c) 168                      (d) 154
5. How many times do the hands of the watch form an angle of 180 degree during a complete day?  
(a) 11 times              (b) 22 times  
(c) 12 times              (d) 24 times
6. A watch which gains 5 seconds in 3 minutes was set right at 7 am. In the afternoon of the same day, when the watch indicated quarter past 4 o'clock, the true time was  
(a)  $59\frac{7}{12}$  minutes past 3 pm  
(b)  $14\frac{22}{37}$  min to 4  
(c)  $58\frac{7}{11}$  minutes past 3 pm  
(d)  $2\frac{3}{11}$  minutes past 4 pm

1.14 > Trigonometry

7. The lengths of the sides of a triangle are 12 cm, 16 cm and 21 cm. The bisector of the greatest angle divides the opposite side into two parts. Find the lengths of these parts.  
 (a) 9 cm, 12 cm            (b) 8 cm, 3 cm  
 (c) 7 cm, 6 cm            (d) None of these
8. Interior angles of the regular dodecagon is  
 (a)  $3\pi/5$                     (b)  $5\pi/7$   
 (c)  $3\pi/4$                     (d)  $5\pi/6$
9. The angles of a polygon are in A.P. The least angle is  $5\pi/12$  and the common difference is  $10^\circ$ , then number of sides is equal to  
 (a) 18                        (b) 4  
 (c) 10                        (d) None of these
10. Find the sum of angles A,B,C,D and E.

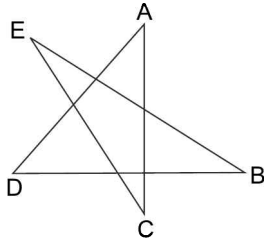

FIGURE 1.17

- (a)  $240^\circ$                     (b)  $180^\circ$   
 (c)  $360^\circ$                     (d) None of these
11. The angle subtended at the centre of a circle of radius 3 metres by an arc of length 1 metre is equal to  
 (a)  $20^\circ$                     (b)  $60^\circ$   
 (c)  $\frac{1}{3}$  radian                (d) 3 radians
12. The radius of the circle whose arc of length 15 cm makes an angle of  $3/4$  radian at the centre is  
 (a) 10 cm                    (b) 20 cm  
 (c)  $11\frac{1}{4}$                     (d)  $22\frac{1}{2}$
13. An ant has to go from A to D where  $AB = BC = CD = 1$  m. Such a poison is kept at place B and C that anything within 1m of it dies immediately. What is the shortest distance, the ant must travel to reach D alive?

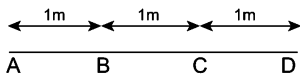

FIGURE 1.18

- (a)  $\pi + 2$                     (b)  $2\pi$   
 (c)  $\pi + 1$                     (d) None of these

14. The sum of the interior angles of a regular polygon is twice the sum of its exterior angles, the polygon is a  
 (a) Hexagon                    (b) Octagon  
 (c) Nonagon                    (d) Decagon
15. The diagram given below shows three circular cans each of diameter 2m they are tied with rope. The length of rope (in metres) is

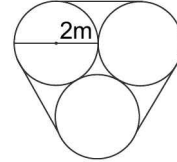

FIGURE 1.19

- (a)  $2\pi + 4$                     (b)  $2\pi + 6$   
 (c)  $2\pi + 4$                     (d)  $3\pi + 6$
16. In the figure below, logs are piled in a particular manner and each log has the same diameter. If the diameter of each log is 3 feet, then the length 'h' (in feet) of a pole that consists three layers is

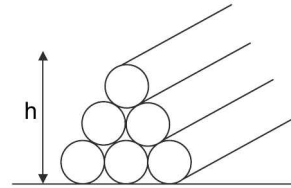

FIGURE 1.20

- (a)  $2 + \sqrt{3}$                     (b)  $3 + \sqrt{3}$   
 (c)  $3 + 3\sqrt{3}$                     (d) None of these
17. In the above question, if the length of a five layered pile is 11 feet, then the diameter of each log (in feet) will be  
 (a)  $2\sqrt{3} - 1$                     (b)  $\sqrt{3} - 1/2$   
 (c)  $2\sqrt{3} - 3\sqrt{2}$                     (d)  $3\sqrt{3} - 2$
18. At what time between 2 and 3 O'clock, both the hands will be at right angle?  
 (a)  $16\frac{4}{11}$  minutes past 2  
 (b)  $26\frac{3}{11}$  minutes past 2  
 (c)  $27\frac{3}{11}$  minutes past 2  
 (d)  $27\frac{5}{11}$  minutes past 2
19. The minute hand of a clock is 10 cm long. What is the area on the face of a clock described by the minute hand between 9 am and 9.35 am?  
 (a)  $183.3 \text{ cm}^2$                     (b)  $11 \text{ cm}^2$   
 (c)  $80 \text{ cm}^2$                     (d)  $84 \text{ cm}^2$

## Answer Keys

1. (d)    2. (d)    3. (d)    4. (a)    5. (b)    6. (b)    7. (a)    8. (d)    9. (b)    10. (b)  
 11. (c)    12. (b)    13. (c)    14. (a)    15. (b)    16. (c)    17. (a)    18. (c)    19. (a)

## TRIGONOMETRIC RATIOS AND THEIR PROPERTIES

We have already defined trigonometrical identities like  $\sin\theta$ ,  $\cos\theta$ ,  $\tan\theta$ ,  $\operatorname{cosec}\theta$ ,  $\sec\theta$  and  $\cot\theta$  in the previous chapter.

This chapter will elaborate a few more properties of these trigonometrical ratios.

### Sign of Trigonometric Ratios

Since  $\sin \angle Q_i O P_i = \frac{P_i Q_i}{O P_i}$ ,  $\cos \angle Q_i O P_i = \frac{O Q_i}{O P_i}$ ;

$$\tan \angle Q_i O P_i = \frac{P_i Q_i}{O Q_i} \quad (i = 1, 2, 3)$$

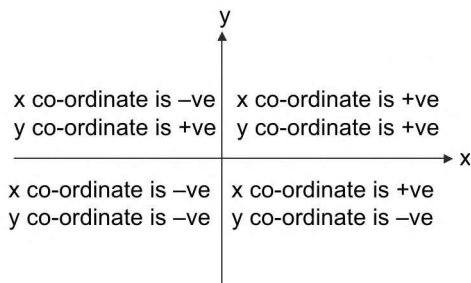

FIGURE 1.22

Therefore depending on signs of  $OQ_i$  and  $P_iQ_i$ , the various trigonometrical ratios will have different signs.

The coordinate or cartesian system is represented in figure. If the angle  $\theta$  lies in the first quadrant

$$\sin \theta = \frac{y}{\sqrt{x^2 + y^2}}, \quad \cos \theta = \frac{x}{\sqrt{x^2 + y^2}}, \quad \tan \theta = \frac{y}{x}$$

(All trigonometrical ratios are positive)

But when  $\theta$  lies in the II<sup>nd</sup> quadrant ( $x < 0$ ,  $y > 0$ ) so  $\cos\theta$  and  $\tan\theta$  becomes -ve but  $\sin\theta$  remains +ve and so on.

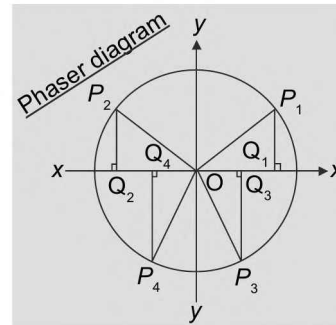

FIGURE 1.23

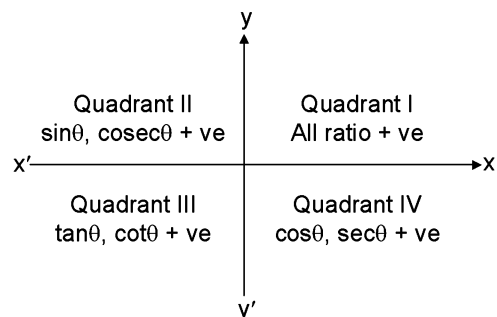

FIGURE 1.24

**Funny face:** An easy way to remember which of the ratios are positive is by using the mnemonics.

**After School To Cinema or Add Sugar To Coffee**

Here dark initial letters represent the angles which are positive in respective quadrants.

**A:** stands for All;

**S:** stands for sine

**T:** stands for tangent;

**C:** stands for cosine

## NOTE

Angle  $\theta$  and  $90^\circ - \theta$  are complementary angles,  $\theta$  and  $180^\circ - \theta$  are supplementary angles.



## ■ TRIGONOMETRIC IDENTITIES

A relation between trigonometric ratios (functions) of one or more unknown angles which is satisfied by all values of the unknown angles is called **Universal Trigonometric Identity**, provided no conditions on unknowns are applied.

### Pythagorean Identities

By Pythagorous theorem

$$\because x^2 + y^2 = r^2 \left( \frac{x}{r} \right)^2 + \left( \frac{y}{r} \right)^2 = 1$$

$$\Rightarrow \cos^2 \theta + \sin^2 \theta = 1$$

$$\Rightarrow 1 + \tan^2 \theta = \sec^2 \theta$$

$$\Rightarrow 1 + \cot^2 \theta = \operatorname{cosec}^2 \theta$$

### Application of pythagorian identity

$$\cos^2 \theta + \sin^2 \theta$$

$$\cos^2 \theta = 1 - \sin^2 \theta$$

$$(\cos \theta) \times (\cos \theta) = (1 - \sin \theta)(1 + \sin \theta)$$

$$\Rightarrow \frac{\cos \theta}{1 + \sin \theta} = \frac{1 - \sin \theta}{\cos \theta}$$

$$\text{similarly, } \frac{\sin \theta}{1 + \cos \theta} = \frac{1 - \cos \theta}{\sin \theta}$$

$$\text{Also, } 1 + \tan^2 \theta = \sec^2 \theta$$

$$\Rightarrow 1 = \sec^2 \theta - \tan^2 \theta \Rightarrow 1 = (\sec \theta - \tan \theta)(\sec \theta + \tan \theta)$$

$$\Rightarrow \frac{1}{\sec \theta + \tan \theta} = \sec \theta - \tan \theta$$

$$\text{And, } 1 + \cot^2 \theta = \operatorname{cosec}^2 \theta \Rightarrow 1 = \operatorname{cosec}^2 \theta - \cot^2 \theta$$

$$\Rightarrow 1 = (\operatorname{cosec} \theta - \cot \theta)(\operatorname{cosec} \theta + \cot \theta)$$

$$\Rightarrow \operatorname{cosec} \theta + \cot \theta = \frac{1}{\operatorname{cosec} \theta - \cot \theta}$$

## TEXTUAL EXERCISE-5 (SUBJECTIVE)

1. Which of the following reduces to unity for  $0^\circ < A < 90^\circ$ ?

(a)  $(\sec^2 A - 1)\cot^2 A$

(b)  $\cos A \operatorname{cosec} A \sqrt{\sec^2 A - 1}$

(c)  $(\operatorname{cosec}^2 A - 1)\tan^2 A$

(d)  $(1 - \cos^2 A)(1 + \cot^2 A)$

(e)  $\sin A \operatorname{cosec} A \sqrt{\operatorname{cosec}^2 A - 1}$

(f)  $(1 + \tan^2 A)(1 - \sin^2 A)$

(g)  $\sec^2 A - \sin^2 A \sec^2 A$

(h)  $\frac{1}{1 + \sin^2 A} + \frac{1}{1 + \operatorname{cosec}^2 A}$

(i)  $\frac{\tan^2 A \sin^2 A}{\tan^2 A - \sin^2 A}$

(j)  $\frac{\cot^2 A \operatorname{cosec}^2 A}{\cot^2 A - \operatorname{cosec}^2 A}$

2. Prove that

$$\begin{aligned} \text{(a)} \quad \frac{1 - \tan^2 \theta}{1 + \tan^2 \theta} &= \cos^2 \theta - \sin^2 \theta = 1 - 2\sin^2 \theta \\ &= 2\cos^2 \theta - 1 \end{aligned}$$

$$\begin{aligned} \text{(b)} \quad \frac{1 + \cos \theta}{1 - \cos \theta} &= (\operatorname{cosec} \theta + \cot \theta)^2 \text{ and } \frac{1 - \cos \theta}{1 + \cos \theta} \\ &= (\operatorname{cosec} \theta - \cot \theta)^2 \end{aligned}$$

$$\text{(c)} \quad \sqrt{\frac{1 - \sin \theta}{1 + \sin \theta}} = |\sec \theta - \tan \theta|$$

3. Prove that  $(\sec \theta + \operatorname{cosec} \theta)(\sin \theta + \cos \theta) = \sec \theta \operatorname{cosec} \theta + 2$ .

4. Prove that  $(\sec^2 \theta + \tan^2 \theta)(\operatorname{cosec}^2 \theta + \cot^2 \theta) = 1 + 2\sec^2 \theta \operatorname{cosec}^2 \theta$ .

5. To prove  $\frac{\sin x + \cos x}{\cos^3 x} = \tan^3 x + \tan^2 x + \tan x + 1$

6. Prove the following identities:

$$\text{(a)} \quad \sqrt{\frac{1 - \sin \theta}{1 + \sin \theta}} = \sec \theta - \tan \theta$$

$$\text{(b)} \quad \frac{1 + \cos \theta + \sin \theta}{1 + \cos \theta - \sin \theta} = \frac{1 + \sin \theta}{\cos \theta}$$

$$\text{(c)} \quad 2(\sin^6 \theta + \cos^6 \theta) - 3(\sin^4 \theta + \cos^4 \theta) + 1 = 0$$

## Answer Keys

1. a, b, c, d, f, g, h, i

## TRIGONOMETRIC RATIOS OF SOME SPECIFIC ANGLES

From geometry, we are already familiar with the construction of angles of  $30^\circ$ ,  $45^\circ$ ,  $60^\circ$  and  $90^\circ$ . In this section, we will find the values of the trigonometric ratios for standard angles i.e.,  $0^\circ$ ,  $30^\circ$ ,  $45^\circ$ ,  $60^\circ$  and  $90^\circ$ .

### Trigonometric Ratios of $45^\circ$

In  $\triangle ABC$ , right-angled at B, if one angle is  $45^\circ$ , then the other angle is also  $45^\circ$ ,

i.e.,  $\angle A = \angle C = 45^\circ$ .

So,  $BC = AB$  as equal angles have equal sides opposite to them.

Now, Suppose  $BC = a$

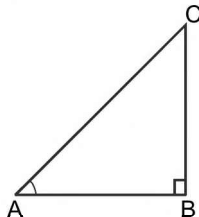

FIGURE 1.25

Then by Pythagoras Theorem,  $AC^2 = AB^2 + BC^2 = a^2 + a^2 = 2a^2$  and therefore  $AC = a\sqrt{2}$ .

Using the definitions of the trigonometric ratios, we have:

$$\begin{aligned}\sin 45^\circ &= \frac{\text{side opposite to angle } 45^\circ}{\text{hypotenuse}} \\ &= \frac{BC}{AC} = \frac{a}{a\sqrt{2}} = \frac{1}{\sqrt{2}}\end{aligned}$$

$$\begin{aligned}\cos 45^\circ &= \frac{\text{side adjacent to angle } 45^\circ}{\text{hypotenuse}} \\ &= \frac{AB}{AC} = \frac{a}{a\sqrt{2}} = \frac{1}{\sqrt{2}}\end{aligned}$$

$$\tan 45^\circ = \frac{\text{side opposite to angle } 45^\circ}{\text{side adjacent to angle } 45^\circ} = \frac{BC}{AB} = \frac{a}{a} = 1$$

$$\text{Also, } \operatorname{cosec} 45^\circ = \frac{1}{\sin 45^\circ} = \sqrt{2}, \quad \sec 45^\circ = \frac{1}{\cos 45^\circ} = \sqrt{2}.$$

$$\& \cot 45^\circ = \frac{1}{\tan 45^\circ} = 1$$

### Trigonometric Ratios of $30^\circ$ and $60^\circ$

Consider an equilateral triangle  $ABC$ . Since each angle in an equilateral triangle is  $60^\circ$ , therefore,  $\angle A = \angle B = \angle C = 60^\circ$ .

Draw the perpendicular  $AD$  from  $A$  to the side  $BC$ .

Now,  $\triangle ABD \cong \triangle ACD$

Therefore  $BD = DC$

and  $\angle BAD = \angle CAD$

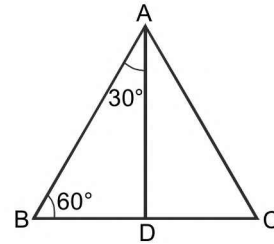

FIGURE 1.26

**Now observe that:**

$\triangle ABD$  is a right triangle, right-angled at  $D$  with  $\angle BAD = 30^\circ$  and  $\angle ABD = 60^\circ$ . Let us suppose that  $AB = 2a$ .

$$\text{Then } BD = \frac{1}{2} BC = a$$

$$\text{and } AD^2 = AB^2 - BD^2 = (2a)^2 - a^2 = 3a^2,$$

$$\text{Therefore } AD = a\sqrt{3}.$$

$$\text{Now, we have: } \sin 30^\circ = \frac{BD}{AB} = \frac{a}{2a} = \frac{1}{2},$$

$$\cos 30^\circ = \frac{AD}{AB} = \frac{a\sqrt{3}}{2a} = \frac{\sqrt{3}}{2},$$

$$\tan 30^\circ = \frac{BD}{AD} = \frac{a}{a\sqrt{3}} = \frac{1}{\sqrt{3}}$$

$$\text{Also } \operatorname{cosec} 30^\circ = \frac{1}{\sin 30^\circ} = 2, \quad \sec 30^\circ = \frac{1}{\cos 30^\circ} = \frac{2}{\sqrt{3}},$$

$$\& \cot 30^\circ = \frac{1}{\tan 30^\circ} = \sqrt{3}$$

Similarly,

$$\sin 60^\circ = \frac{AD}{AB} = \frac{a\sqrt{3}}{2a} = \frac{\sqrt{3}}{2}, \quad \cos 60^\circ = \frac{1}{2},$$

$$\tan 60^\circ = \sqrt{3}, \quad \operatorname{cosec} 60^\circ = \frac{2}{\sqrt{3}}, \quad \sec 60^\circ = 2 \text{ and}$$

$$\cot 60^\circ = \frac{1}{\sqrt{3}}.$$

### Trigonometric Ratios of $0^\circ$ and $90^\circ$

Let us observe what happens to the trigonometric ratios of angle  $A$ , if it is made smaller and smaller in the right triangle  $ABC$ , till it becomes zero. As  $\angle A$  gets smaller and smaller, the length of the side  $BC$  decreases. The point  $C$  gets closer to point  $B$ , and finally when  $\angle A$  becomes very close to  $0^\circ$ ,  $AC$  becomes almost the same as  $AB$ . (see fig.)

1.18 ➤ Trigonometry

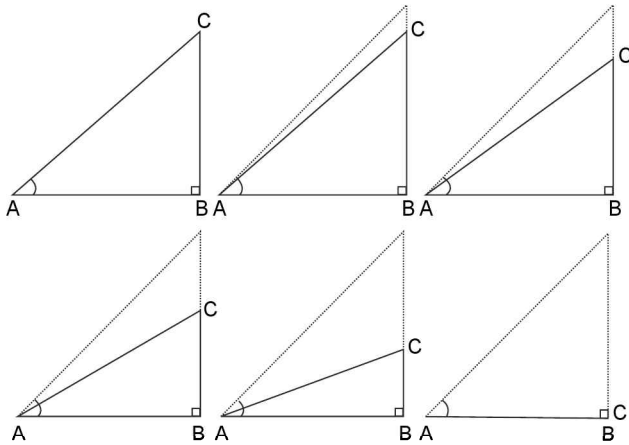

FIGURE 1.27

When  $\angle A$  is very close to  $0^\circ$ ,  $BC$  gets very close to 0 and so the value of  $\sin A = \frac{BC}{AC}$  is very close to 0. Also, when  $\angle A$  is very close to  $0^\circ$ ,  $AC$  is nearly the same as  $AB$  and so the value of  $\cos A = \frac{AB}{AC}$  is very close to 1.

With the help of the above information, we can define the values of  $\sin A$  and  $\cos A$  when  $A = 0^\circ$ .

We define:  $\sin 0^\circ = 0$  and  $\cos 0^\circ = 1$ .

Using these values, we have:

$$\tan 0^\circ = \frac{\sin 0^\circ}{\cos 0^\circ} = 0,$$

$$\cot 0^\circ = \frac{1}{\tan 0^\circ}, \text{ which is not defined.}$$

$$\sec 0^\circ = \frac{1}{\cos 0^\circ} = 1$$

$$\operatorname{cosec} 0^\circ = \frac{1}{\sin 0^\circ}, \text{ which is again not defined.}$$

Now, similarly, we can get the trigonometric ratios for the angle  $90^\circ$  when  $\angle A$  is made larger and larger; and hence  $\angle C$  gets smaller and smaller. Therefore the length of the side  $AB$  goes on decreasing i.e., the point  $A$  gets closer to

point  $B$ . Finally, when  $\angle A$  is very close to  $90^\circ$ ,  $\angle C$  becomes very close to  $0^\circ$  and the side  $AC$  almost coincides with  $BC$ .

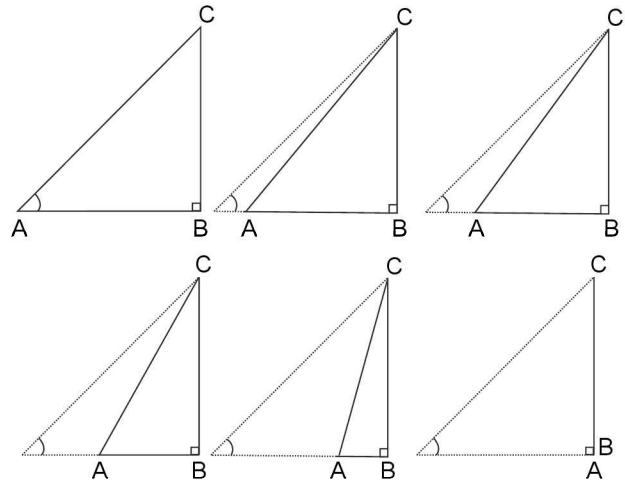

FIGURE 1.28

So, we define:  $\sin 90^\circ = 1$  and  $\cos 90^\circ = 0$ .

Fill in the rest of the blanks yourself.

$\angle A$	$0^\circ$	$30^\circ$	$45^\circ$	$60^\circ$	$90^\circ$
$\sin A$	0	–	$\frac{1}{\sqrt{2}}$	–	1
$\cos A$	–	$\frac{\sqrt{3}}{2}$	–	$\frac{1}{2}$	0
$\tan A$	0	–	1	–	–
$\operatorname{cosec} A$	–	2	–	$\frac{2}{\sqrt{3}}$	1
$\sec A$	–	$2/\sqrt{3}$	$\sqrt{2}$	–	Not defined
$\cot A$	Not defined	$\sqrt{3}$	1	–	–

**REMARK**

From the table given above you can observe that as  $\angle A$  increases from  $0^\circ$  to  $90^\circ$ ,  $\sin A$  increases from 0 to 1 and  $\cos A$  decreases from 1 to 0.

Every trigonometric function can be discussed in two ways i.e.,

- (i) Graph diagram and
- (ii) Circle (Phaser) diagram

**Sin x and Cosc x**

(a)  $f(x) = \sin x$ :

**Circle Diagram:** Consider a circle of radius '1', i.e., unit circle on the trigonometric plane as shown in the figure.

Then  $\sin\alpha = a/1$ ,  $\sin\beta = b/1$   
 $\sin\gamma = -c/1$ ,  $\sin\delta = -d/1$ ...  
 $\therefore \sin x$  generates a circle of radius 1.

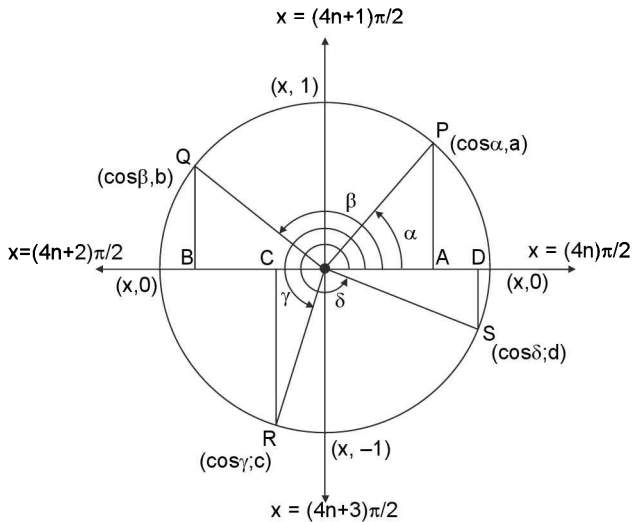

FIGURE 1.29

**Graph diagram:** Let  $f(x) = \sin x$ , increases strictly from  $-1$  to  $1$  as  $x$  increases from  $-\pi/2$  to  $\pi/2$ , decreases from  $\pi/2$  to  $3\pi/2$  and so on. So the graph of  $\sin x$  will be as shown in the figure given below.

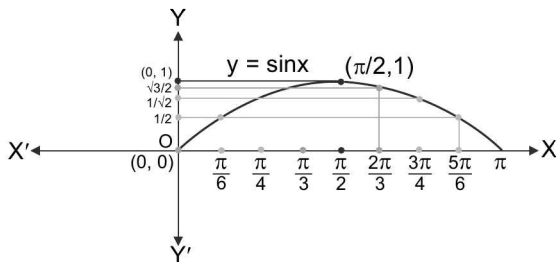

FIGURE 1.30

**Properties**

1. Domain of  $\sin x$  is  $\mathbb{R}$  and range is  $[-1, 1]$ .
2.  $\sin x$  is periodic function with period  $2\pi$ .
3. Principal domain is  $[-\pi/2, \pi/2]$ .

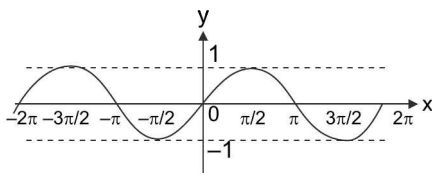

FIGURE 1.31

4. It is an odd function.
5. It is a continuous function and increases in first and fourth quadrants while decreases in second and third quadrants in trigonometric plane.

(b)  $f(x) = \operatorname{cosec} x$ :  $\operatorname{cosec} x$  is reciprocal of  $\sin x$ .

**Properties**

1. The domain is  $\mathbb{R} - \{n\pi \mid n \in \mathbb{Z}\}$ .
2. Range of  $\operatorname{cosec} x$  is  $\mathbb{R} - (-1, 1)$ .
3. Principal domain is:  $[-\pi/2, \pi/2] - \{0\}$
4. The  $\operatorname{cosec} x$  is periodic with period  $2\pi$ .

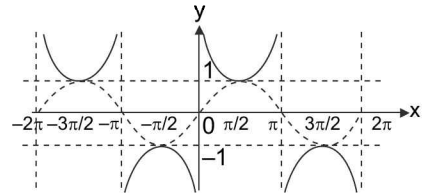

FIGURE 1.32

5. It is odd function discontinuous at  $x = n\pi$ ,  $n \in \mathbb{Z}$
6. It decreases in first and fourth quadrants while increases in second and third quadrants in trigonometric plane.

**Cos x and sec x**

(a)  $f(x) = \cos x$ :

**Circle Diagram:** Let a circle of radius 1, i.e., a unit circle where  $OA = a$ ,  $OB = b$ ,  $OC = c$ ,  $OD = d$ . Then  $\cos\alpha = a/1$ ,  $\cos\beta = -b/1$ ,  $\cos\gamma = -c/1$ ,  $\cos\delta = d/1$

$\therefore \cos x$  generates a circle of radius 1.

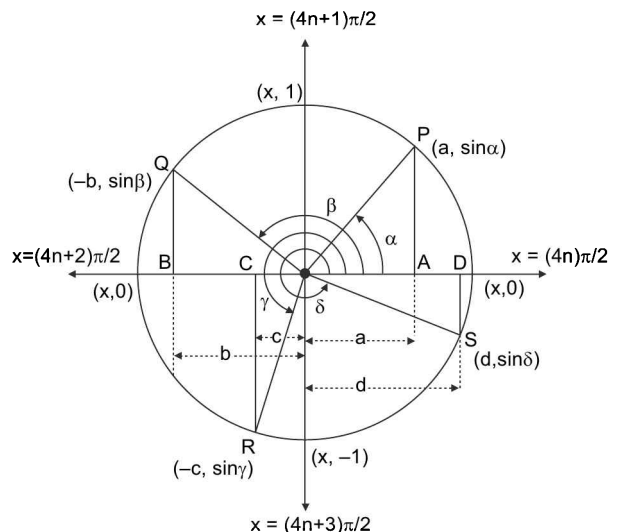

FIGURE 1.33

1.20 > Trigonometry

**Graph Diagram:** As discussed,  $\cos x$  decreases strictly from 1 to  $-1$  as  $x$  increases from 0 to  $\pi$ , increases strictly from  $-1$  to 1 as  $x$  increases from  $\pi$  to  $2\pi$  and so on.

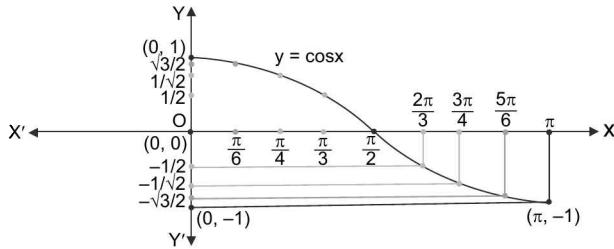

FIGURE 1.34

**Properties**

1. The domain of  $\cos x$  is  $\mathbb{R}$  and the range is  $[-1, 1]$ .
2. Principal domain is  $[0, \pi]$ .
3.  $\cos x$  is periodic with period  $2\pi$ .
4. It is an even function so symmetric about  $y$ -axis.

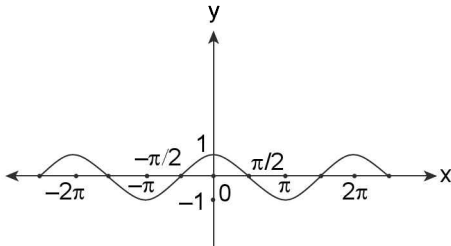

FIGURE 1.35

5. It is continuous function which decreases in Ist and IInd quadrant and increases in IIIrd and IVth quadrant in trigonometric plane.

(b)  $f(x) = \sec x$ :  $\sec x$  is reciprocal of  $\cos x$ .

1. The domain of  $\sec x$  is  $\mathbb{R} - \left\{ (2n+1)\frac{\pi}{2} \mid n \in \mathbb{Z} \right\}$  and range is  $\mathbb{R} - (-1, 1)$
2. The  $\sec x$  is periodic with period  $2\pi$ .
3. Principal domain is  $[0, \pi] - \{ \pi/2 \}$ .
4. It is discontinuous at  $x = (2n + 1) \pi/2; n \in \mathbb{Z}$

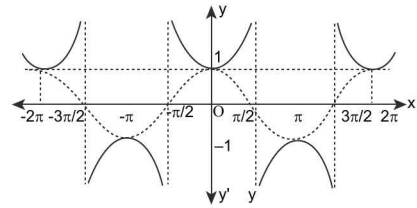

FIGURE 1.36

**Tan x and Cot x**

(a)  $y = \tan x$ :

1. The domain of  $\tan x$  is  $\mathbb{R} - \{ (2n + 1)\pi/2 \}$  and range  $\mathbb{R}$  or  $(-\infty, \infty)$ . Principal Domain is  $(-\pi/2, \pi/2)$

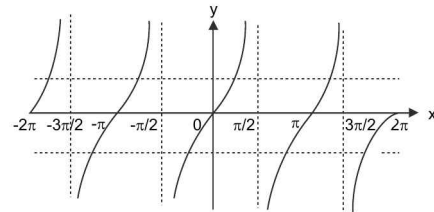

FIGURE 1.37

2. It is periodic with period  $\pi$ .
3. It is discontinuous at  $x \in \mathbb{R} - \{ (2n + 1)\pi/2; n \in \mathbb{Z} \}$  and it is strictly increasing function in its domain

(b)  $y = \cot x$ :  $\cot x$  is reciprocal of  $\tan x$ .

1. The domain of  $f(x) = \cot x$  is  $\mathbb{R} - \{ n\pi : n \in \mathbb{Z} \}$  and Range =  $\mathbb{R}$ .
2. It is periodic with period  $\pi$  and has  $x = n\pi, n \in \mathbb{Z}$  as its asymptotes.
3. Principal domain is:  $(0, \pi)$
4. It is discontinuous at  $x = n\pi; n \in \mathbb{Z}$
5. It is strictly decreasing function in its domain

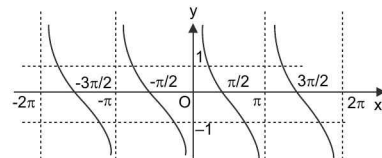

FIGURE 1.38

**NOTES**

From observation using the theory just covered, we can generalize that

- (i)  $\sin\{n\pi + (-1)^n \theta\} = \sin \theta; n \in \mathbb{Z}$ .      (ii)  $\cos (2n\pi \pm \theta) = \cos \theta, n \in \mathbb{Z}$       (iii)  $\tan (n\pi + \theta) = \tan \theta, n \in \mathbb{Z}$ .

**TEXTUAL EXERCISE-6 (SUBJECTIVE)**

- Find the value of  $\cos A - \sin A$  and  $\tan A + \cot A$  when  $A$  is equal to
    - $11\pi/3$
    - $7\pi/4$
  - Find the sign of  $\sin \alpha - \cos \alpha$  when  $\alpha = 825^\circ$  and  $\sin \alpha + \cos \alpha$  when  $\alpha = 140^\circ$ .
  - Find the sign of  $\tan \alpha - \cot \alpha$  where  $\alpha = 235^\circ, 325^\circ$ .
  - Find the sign of  $\sec \alpha - \operatorname{cosec} \alpha$  where  $\alpha = 125^\circ, 215^\circ$ .
5. Fill in the rest of the blanks yourself.

	I quad.	II quad.	III quad.	IV quad.
$\sin \theta$			↓ from 0 to -1	↑ from -1 to 0
$\cos \theta$	↓ from 1 to 0			↑ from 0 to 1
$\tan \theta$		↑ from $-\infty$ to 0	↑ from 0 to $\infty$	
$\cot \theta$	↓ from $\infty$ to 0			↓ from 0 to $-\infty$
$\sec \theta$		↑ from $-\infty$ to -1		
$\operatorname{cosec} \theta$	↓ from $\infty$ to 1		↑ from $-\infty$ to -1	

**Answer Keys**

1. (a)  $\frac{\sqrt{3}+1}{2}$  and  $\frac{-4}{\sqrt{3}}$  (b)  $\sqrt{2}$  and  $-2$     2. +ve, -ve    3. +ve, +ve    4. -ve, +ve
- 5.

	I quad.	II quad.	III quad.	IV quad.
$\sin \theta$	↑ from 0 to 1	↓ from 1 to 0	↓ from 0 to -1	↑ from -1 to 0
$\cos \theta$	↓ from 1 to 0	↓ from 0 to -1	↑ from -1 to 0	↑ from 0 to 1
$\tan \theta$	↑ from 0 to $\infty$	↑ from $-\infty$ to 0	↑ from 0 to $\infty$	↑ from $-\infty$ to 0
$\cot \theta$	↓ from $\infty$ to 0	↓ from 0 to $-\infty$	↓ from $\infty$ to 0	↓ from 0 to $-\infty$
$\sec \theta$	↑ from 1 to $\infty$	↑ from $-\infty$ to -1	↓ from -1 to $-\infty$	↓ from $\infty$ to 1
$\operatorname{cosec} \theta$	↓ from $\infty$ to 1	↑ from 1 to $\infty$	↑ from $-\infty$ to -1	↓ from -1 to $-\infty$

**SOME IMPORTANT GRAPHICAL DEDUCTIONS**

To find relation between  $\sin x$ ,  $x$  and  $\tan x$

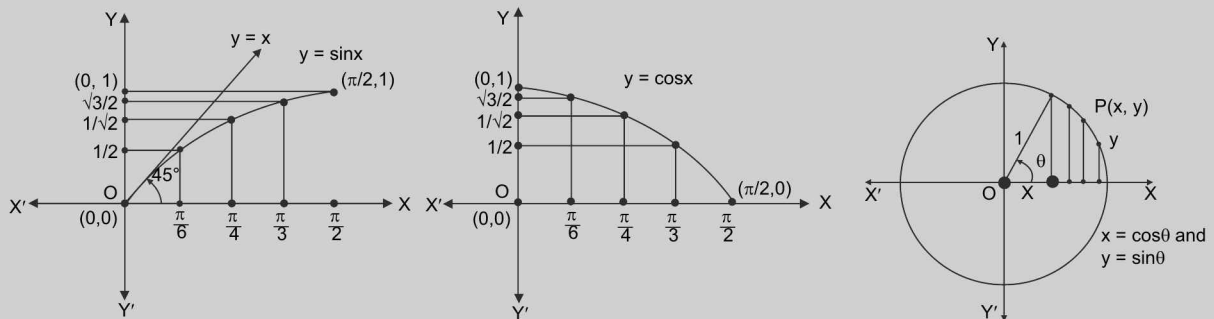

FIGURE 1.39

$$y = \sin x \uparrow \forall x \in (-\pi/2, \pi/2) \Rightarrow \frac{dy}{dx} = \cos x > 0 \forall x \in (-\pi/2, \pi/2) \text{ and } \frac{d^2y}{dx^2} = -\sin x \begin{cases} > 0 & \text{if } x \in (-\pi/2, 0) \\ < 0 & \text{if } x \in (0, \pi/2) \end{cases}$$

1.22 > Trigonometry

And hence in the graph of  $\sin x$ , the curvature is concave down in  $(0, \pi/2)$  and concave up in  $(-\pi/2, 0)$ .

$\tan x$  is an increasing function since

$$\because \frac{dy}{dx} = \sec^2 x > 0 \quad \forall x \in \left(0, \frac{\pi}{2}\right) \quad \tan x \text{ has concave up graph}$$

$$\because \frac{d^2y}{dx^2} = 2 \sec^2 x \tan x > 0 \quad \forall x \in \left(0, \frac{\pi}{2}\right)$$

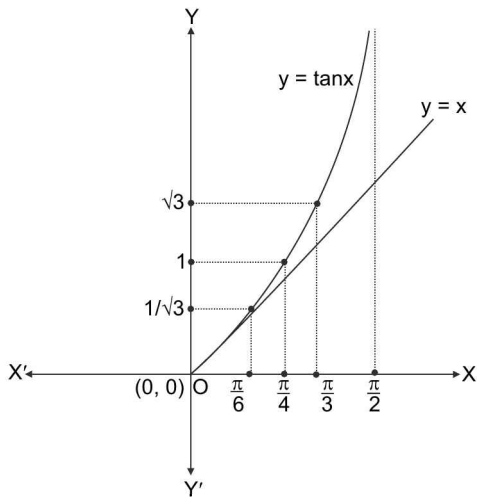

FIGURE 1.40

i.e., graph of  $\tan x$  is increasing with an increasing rate.

To summarise, we conclude that

$$\left. \begin{aligned} \sin x < x \quad \forall x \in (0, \infty) \\ \sin x > x \quad \forall x \in (-\infty, 0) \\ \tan x > x \quad \forall x \in \left(0, \frac{\pi}{2}\right) \\ \tan x < x \quad \forall x \in \left(-\frac{\pi}{2}, 0\right) \end{aligned} \right\}$$

$$\Rightarrow \tan x > x > \sin x \quad \forall x \in \left(0, \frac{\pi}{2}\right) \text{ and}$$

$$\sin x > x > \tan x \quad \forall x \in \left(-\frac{\pi}{2}, 0\right)$$

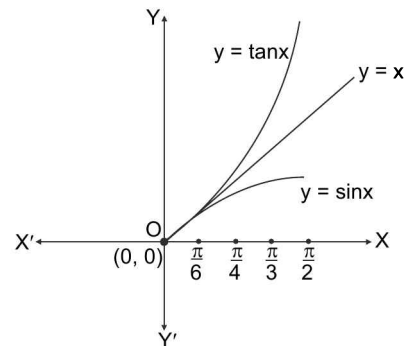

FIGURE 1.41

**TEXTUAL EXERCISE-7 (SUBJECTIVE)**

1. Find solution of the following equation.

(a)  $\sin \theta = x + \frac{1}{x}$

(b)  $\sec \theta = \frac{x}{1+x^2}$

(c)  $\sin \theta = \frac{1+x^2}{2x}$  for  $[0, 2\pi]$

(d)  $\sin^2 \theta = \frac{x^2 + y^2}{2xy}$

2. Find ordered pairs  $(x, \theta)$  satisfying  $\sin \theta = |x| + 1$  when  $\theta \in (-2\pi, 3\pi)$ .

3. How many values of  $x$  are there in  $[0, \pi]$  when

(a)  $\sin x = 5/7$                       (b)  $\cot x = -7$

4. Prove the following inequalities:

(a)  $4 \tan^2 x + 49 \cot^2 x \geq 28$

(b)  $8 \sin^4 x + 2 \operatorname{cosec}^4 x \geq 8$

5. Are the following equations possible for real  $x$ ?

(a)  $2 \cos^2 x - 7 \cos x + 3 = 0$

(b)  $6 \cos^2 x + 7 \sin x - 8 = 0$

(c)  $\sin^2 x + 2 \sin^2 \frac{x}{2} + 4 = 0$

6. For  $0 < \phi < \pi/2$  if  $x = \sum_{n=0}^{\infty} \cos^{2n} \phi$ ,  $y = \sum_{n=0}^{\infty} \sin^{2n} \phi$ ,

$z = \sum_{n=0}^{\infty} \cos^{2n} \phi \sin^{2n} \phi$ , then prove that

(a)  $\frac{xy}{xy-1} = z$

(b)  $x + y + z = xyz$

**Answer Keys**

1. (a) No solution      (b) No solution      (c)  $\{\pi/2, 3\pi/2\}$       (d)  $\theta = (2k+1)\frac{\pi}{2}; x = y \neq 0$

2.  $(0, -3\pi/2); (0, \pi/2)$  and  $(0, 5\pi/2)$       3. (a) 2      (b) 1      5. (a) yes      (b) Yes      (c) No

## TRIGONOMETRIC RATIOS FOR ALLIED ANGLES

Two angles are said to be allied when their sum or difference is either zero or a multiple of  $90^\circ$ . e.g.,  $-\theta, \frac{\pi}{2} \pm \theta, \pi \pm \theta, 2\pi \pm \theta$  etc. are called allied angles of  $\theta$ .

Degrees	Radians	General	Allied angles of $\theta$
0	$2\pi^c$	$2n\pi$	$2n\pi \pm \theta$
$90^\circ$	$\pi/2$	$(4n+1)\pi/2$	$(2n+1)\pi \pm \theta$
$180^\circ$	$\pi^c$	$(2n+1)\pi$	$(4n+1)\pi \pm \theta$
$270^\circ$	$3\pi/2$	$(4n-1)\pi/2$	$(4n-1)\pi \pm \theta$

$$\sin(2n\pi + \theta) = \sin \theta, \quad \cos(2n\pi + \theta) = \cos \theta,$$

$$\tan(2n\pi + \theta) = \tan \theta.$$

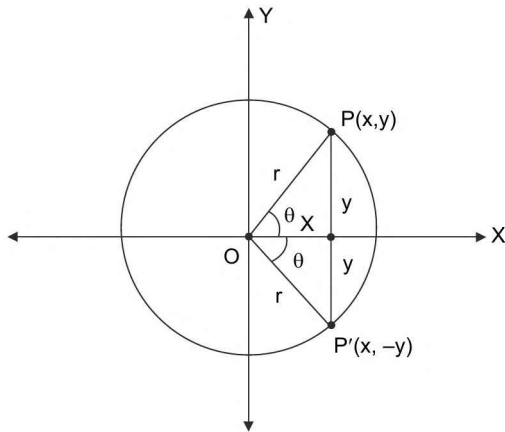

FIGURE 1.42

$$\sin(2n\pi - \theta) = -\sin \theta, \quad \cos(2n\pi - \theta) = \cos \theta$$

$$\tan(2n\pi - \theta) = -\tan \theta$$

### Trigonometric ratios of $\left(\frac{\pi}{2} \pm \theta\right)$ in terms of $\theta$

#### 1st Method

To find the trigonometrical ratios of the angle  $(90^\circ + \theta)$  as a trigonometric ratios of the angle  $\theta, \forall \theta \in \mathbb{R}$ .

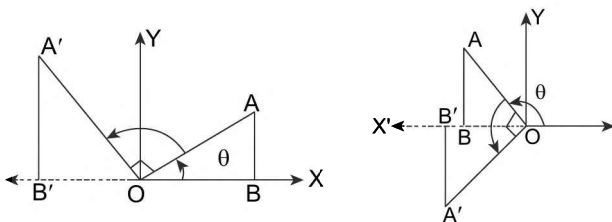

FIGURE 1.43

Consider a line initially at  $OX$ , that rotates about the point  $O$  such that it traces an angle  $\theta$  when it is at  $OA$ .

$$\therefore \angle AOX = \theta$$

Let the revolving line turn through a right angle from  $OA$  in the positive direction to the position  $OA'$ , so that the angle  $XOA'$  is  $(90^\circ + \theta)$ .

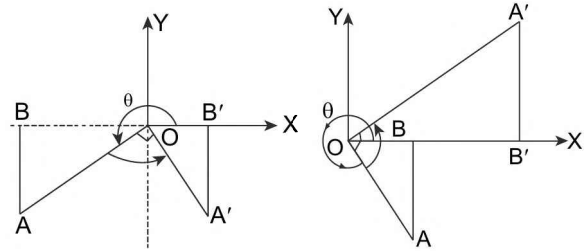

FIGURE 1.44

Take  $OA'$  equal to  $OA$  and draw  $AB$  and  $A'B'$  perpendicular  $XO$ , produced if necessary. In each figure, since  $AOA'$  is a right angle, the sum of the angle  $BOA$  and  $A'OB'$  is always a right angle.

$$\text{Hence } \angle BOA = 90^\circ - \angle A'OB' = \angle OA'B'.$$

The two triangles  $BOA$  and  $B'A'O$  are therefore, congruent.

In each figure,  $OB$  and  $B'A'$  have the same sign, while  $BA$  and  $OB'$  have the opposite sign, so that

$$B'A' = OB, \text{ and } OB' = -BA$$

Hence,

$$\sin(90^\circ + \theta) = \sin \angle XOA' = \frac{B'A'}{OA'} = \frac{OB}{OA} = \cos \theta$$

$$\cos(90^\circ + \theta) = \cos \angle XOA' = \frac{OB'}{OA'} = \frac{-BA}{OA} = -\sin \theta,$$

$$\tan(90^\circ + \theta) = \tan \angle XOA' = \frac{B'A'}{OB'} = \frac{OB}{-BA} = -\cot \theta,$$

$$\cot(90^\circ + \theta) = \cot \angle XOA' = \frac{OB'}{B'A'} = \frac{-BA}{OB} = -\tan \theta$$

$$\sec(90^\circ + \theta) = \sec \angle XOA' = \frac{OA'}{OB'} = \frac{OA}{-BA} = -\operatorname{cosec} \theta,$$

$$\text{and } \operatorname{cosec}(90^\circ + \theta) = \operatorname{cosec} \angle XOA' = \frac{OA'}{B'A'} = \frac{OA}{BA} = \sec \theta.$$

#### Example:

$$\sin 150^\circ = \sin(90^\circ + 60^\circ) = \cos 60^\circ = \frac{1}{2},$$

$$\cos 135^\circ = \cos(90^\circ + 45^\circ) = -\sin 45^\circ = -\frac{1}{\sqrt{2}},$$

$$\text{and } \tan 120^\circ = \tan(90^\circ + 30^\circ) = -\cot 30^\circ = -\sqrt{3}$$

$$\sin((4k+1)\pi/2 - \theta) = \cos \theta;$$

$$\cos((4k+1)\pi/2 - \theta) = \sin \theta;$$

$$\tan((4k+1)\pi/2 - \theta) = \cot \theta.$$



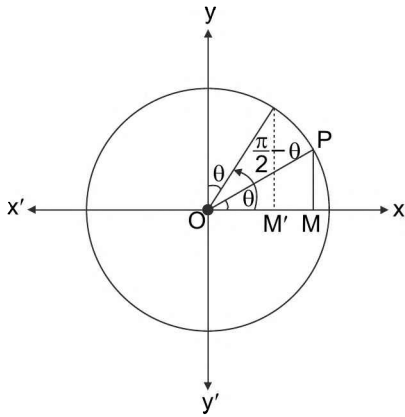

FIGURE 1.45

$$\begin{aligned} \sin((4k + 1)\pi/2 + \theta) &= \cos \theta; \\ \cos((4k + 1)\pi/2 + \theta) &= -\sin \theta; \\ \tan((4k + 1)\pi/2 + \theta) &= -\cot \theta. \end{aligned}$$

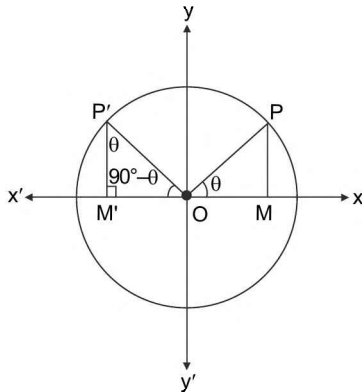

FIGURE 1.46

**II<sup>nd</sup> Method : To Prove**

$$\cos\left(\frac{\pi}{2} \pm \theta\right) = \mp \sin \theta \text{ and } \sin\left(\frac{\pi}{2} \pm \theta\right) = \cos \theta$$

**Proof**

$$\begin{aligned} e^{i\left(\frac{\pi}{2} \pm \theta\right)} &= \cos\left(\frac{\pi}{2} \pm \theta\right) + i \sin\left(\frac{\pi}{2} \pm \theta\right) \\ \Rightarrow e^{i\frac{\pi}{2}} \cdot e^{i(\pm\theta)} &= \cos\left(\frac{\pi}{2} \pm \theta\right) + i \sin\left(\frac{\pi}{2} \pm \theta\right) \\ \Rightarrow i \cos(\pm\theta) + i^2 \sin(\pm\theta) &= \cos\left(\frac{\pi}{2} \pm \theta\right) + i \sin\left(\frac{\pi}{2} \pm \theta\right) \\ \Rightarrow i \cos \theta \mp \sin \theta &= \cos\left(\frac{\pi}{2} \pm \theta\right) + i \sin\left(\frac{\pi}{2} \pm \theta\right) \\ \Rightarrow i \cos \theta \mp \sin \theta &= \cos\left(\frac{\pi}{2} \pm \theta\right) + i \sin\left(\frac{\pi}{2} \pm \theta\right) \end{aligned}$$

Comparing the real and imaginary parts of L.H.S and R.H.S we get the desired results.

**TRIGONOMETRIC RATIOS OF  $(\pi \pm \theta)$  IN TERMS OF  $\theta$**

**1<sup>st</sup> Method:**

To find the trigonometrical ratios of the angle  $(180^\circ - \theta)$  as a function of trigonometric ratios of angle ' $\theta$ '  $\forall \theta \in \mathbb{R}$ .

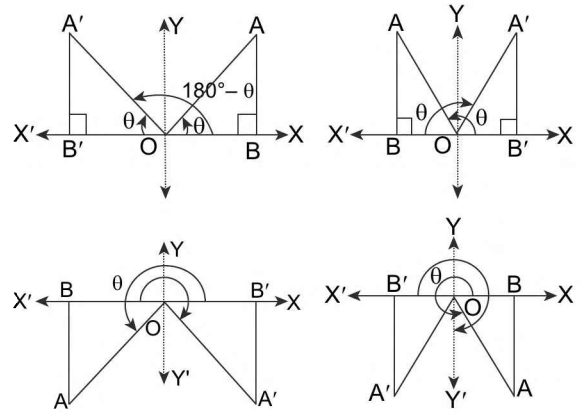

FIGURE 1.47

Consider a line initially at  $OX$ , that rotate about the point  $O$  such that it traces an angle  $\theta$  when it is at  $OA$ .

$$\therefore \angle AOX = \theta$$

To obtain the angle  $180^\circ - \theta$ , let the revolving line start from  $OX$  and, after revolving through two right angle (i.e., into the position  $OX'$ ), then revolve back through an angle  $\theta$  into the position  $OA'$ , so that the angle  $X'OA'$  is equal in magnitude but opposite in sign to the angle  $XOA$ .

The angle  $XOA'$  is then  $180^\circ - \theta$ . Take  $OA'$  equal to  $OA$ , and draw  $A'B'$  and  $AB$  perpendicular to  $XOX'$ .

The angles  $BOA$  and  $B'OA'$  are equal and hence the triangles  $BOA$  and  $B'OA'$  are congruent triangle.

Hence  $OB$  and  $OB'$  are equal in magnitude and so also are  $AB$  and  $A'B'$ . In each figure,  $OB$  and  $OB'$  are drawn in opposite directions, while  $BA$  and  $B'A'$  are drawn in the same directions, so that.

$$OB' = -OB, \text{ and } B'A' = +BA$$

$$\text{Hence, } \sin(180^\circ - \theta) = \sin \angle XOA' = \frac{B'A'}{OA'} = \frac{BA}{OA} = \sin \theta$$

$$\cos(180^\circ - \theta) = \cos \angle XOA' = \frac{OB'}{OA'} = \frac{-OB}{OA} = -\cos \theta,$$

$$\tan(180^\circ - \theta) = \tan \angle XOA' = \frac{B'A'}{OB'} = \frac{BA}{-OB} = -\tan \theta,$$

$$\cot(180^\circ - \theta) = \cot \angle XOA' = \frac{OB'}{B'A'} = \frac{-OB}{BA} = -\cot \theta$$

$$\sec(180^\circ - \theta) = \sec \angle XOA' = \frac{OA'}{OB'} = \frac{OA}{-OB} = -\sec \theta,$$

and  $\operatorname{cosec}(180^\circ - \theta) = \operatorname{cosec} \angle AOP'$

$$= \frac{OA'}{B'A'} = \frac{OA}{BA} = \operatorname{cosec} \theta.$$

**Example:**

$$\sin 120^\circ = \sin(180^\circ - 60^\circ) = \sin 60^\circ = \frac{\sqrt{3}}{2},$$

$$\cos 135^\circ = \cos(180^\circ - 45^\circ) = -\cos 45^\circ = -\frac{1}{\sqrt{2}}, \text{ and}$$

$$\tan 150^\circ = \tan(180^\circ - 30^\circ) = -\tan 30^\circ = -\frac{1}{\sqrt{3}}.$$

$$\sin((2n + 1)\pi - \theta) = \sin \theta;$$

$$\cos((2n + 1)\pi - \theta) = -\cos \theta;$$

$$\tan((2n + 1)\pi - \theta) = -\tan \theta.$$

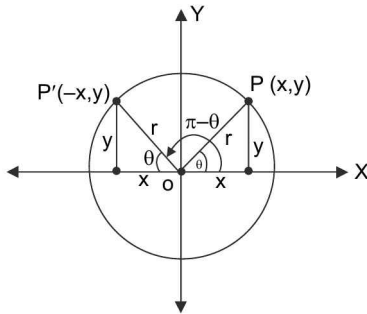

FIGURE 1.48

$$\sin((2n + 1)\pi + \theta) = -\sin \theta;$$

$$\cos((2n + 1)\pi + \theta) = -\cos \theta;$$

$$\tan((2n + 1)\pi + \theta) = \tan \theta.$$

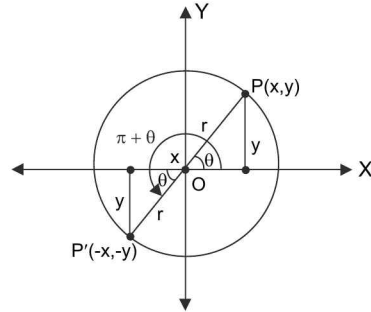

FIGURE 1.49

**Ind Method: Trigonometric Ratios of  $(\pi \pm \theta)$  in Terms of  $\theta$**

**Proof:**

Since,  $e^{i(\pi \pm \theta)} = \cos(\pi \pm \theta) + i \sin(\pi \pm \theta)$

$$\therefore e^{i\pi} \cdot e^{i(\pm \theta)} = \cos(\pi \pm \theta) + i \sin(\pi \pm \theta)$$

$$\Rightarrow -[\cos(\pm \theta) + i \sin(\pm \theta)] = \cos(\pi \pm \theta) + i \sin(\pi \pm \theta)$$

$$\Rightarrow -[\cos \theta \pm i \sin \theta] = \cos(\pi \pm \theta) + i \sin(\pi \pm \theta)$$

$$\Rightarrow -\cos \theta \mp i \sin \theta = \cos(\pi \pm \theta) + i \sin(\pi \pm \theta)$$

Comparing real and imaginary parts, we get

$$\Rightarrow \cos(\pi \pm \theta) = -\cos \theta; \sin(\pi \pm \theta) = \mp \sin \theta$$

Similarly, other relations can be defined and are summarised in the following table.

Conversion of trigonometric functions for allied angles						
$\downarrow \rightarrow f(\alpha)$ $\alpha$	$\sin \alpha$	$\cos \alpha$	$\tan \alpha$	$\cot \alpha$	$\sec \alpha$	$\operatorname{cosec} \alpha$
$-\theta$	$-\sin \theta$	$\cos \theta$	$-\tan \theta$	$-\cot \theta$	$\sec \theta$	$-\operatorname{cosec} \theta$
$90^\circ - \theta$	$\cos \theta$	$\sin \theta$	$\cot \theta$	$\tan \theta$	$\operatorname{cosec} \theta$	$\sec \theta$
$90^\circ + \theta$	$\cos \theta$	$-\sin \theta$	$-\cot \theta$	$-\tan \theta$	$-\operatorname{cosec} \theta$	$\sec \theta$
$180^\circ - \theta$	$\sin \theta$	$-\cos \theta$	$-\tan \theta$	$-\cot \theta$	$-\sec \theta$	$\operatorname{cosec} \theta$
$180^\circ + \theta$	$-\sin \theta$	$-\cos \theta$	$\tan \theta$	$\cot \theta$	$-\sec \theta$	$-\operatorname{cosec} \theta$
$270^\circ - \theta$	$-\cos \theta$	$-\sin \theta$	$\cot \theta$	$\tan \theta$	$-\operatorname{cosec} \theta$	$-\sec \theta$
$270^\circ + \theta$	$-\cos \theta$	$\sin \theta$	$-\cot \theta$	$-\tan \theta$	$\operatorname{cosec} \theta$	$-\sec \theta$
$360^\circ - \theta$	$-\sin \theta$	$\cos \theta$	$-\tan \theta$	$-\cot \theta$	$\sec \theta$	$-\operatorname{cosec} \theta$
$360^\circ + \theta$	$\sin \theta$	$\cos \theta$	$\tan \theta$	$\cot \theta$	$\sec \theta$	$\operatorname{cosec} \theta$

**The generalized forms of the previously discussed conversions:**

- $\cos k\pi = (-1)^k \sin k\pi = 0$ ; when  $k \in \mathbb{Z}$
- $\cos \frac{k\pi}{2} = 0, \sin \frac{k\pi}{2} = (-1)^{\frac{k-1}{2}}$  where  $k = (2n + 1); n \in \mathbb{Z}$

- $\cos(k\pi + \theta) = (-1)^k \cos \theta$  when  $k \in \mathbb{Z}$
- $\sin(k\pi + \theta) = (-1)^k \sin \theta$  when  $k \in \mathbb{Z}$
- $\cos(k\pi/2 + \theta) = (-1)^{\frac{k+1}{2}} \sin \theta$  where  $k \in$  odd integer
- $\sin(k\pi/2 + \theta) = (-1)^{\frac{k-1}{2}} \cos \theta$  where  $k \in$  odd integer

**TEXTUAL EXERCISE-8 (SUBJECTIVE)**

- Find the value of
  - $\sin 120^\circ$
  - $\tan 150^\circ$
  - $\cos 300^\circ$
  - $\tan 1140^\circ$
  - $\sec 1320^\circ$
- Prove that
  - $\sec(3\pi/2 - A) \sec(\pi/2 - A) - \tan(3\pi/2 - A) \tan(\pi/2 + A) + 1 = 0$
  - $\cot A + \tan(\pi + A) + \tan(\pi/2 + A) + \tan(2\pi - A) = 0$
- If  $A, B, C$  are the angles of a triangle, then  $\cos(A + B) = \cos(\pi - C) = -\cos C$  and hence show that
 
$$\sin\left(\frac{B+C}{2}\right) = \sin(\pi/2 - A/2) = \cos A/2$$
- If  $ABCD$  is a quadrilateral, then show that
  - $\cos\frac{B+C}{2} + \cos\frac{A+D}{2} = 0$
  - $\tan\frac{A+C}{4} = \cot\frac{B+D}{4}$
- Fill in the rest of the blanks yourself.

$\angle A$	$0^\circ$	$30^\circ$	$45^\circ$	$60^\circ$	$90^\circ$	$120^\circ$	$135^\circ$	$150^\circ$	$180^\circ$	$210^\circ$	$225^\circ$	$240^\circ$	$270^\circ$	$300^\circ$	$315^\circ$	$330^\circ$	$360^\circ$
SinA	0	1/2	1/√2	√3/2	1												
CosA	1	√3/2	1/√2	1/2	0												
TanA	0	1/√3	1	√3	ND												
CosecA	ND	2	√2	2√3	1												
SecA	1	2/√3	√2	2	ND												
CotA	ND	√3	1	1/√3	0												

**Answer Keys**

- $\sin 60^\circ$  or  $\cos 30^\circ$
  - $-\tan 30^\circ$  or  $-\cot 60^\circ$
  - $\cos 60^\circ$  or  $\sin 30^\circ$
  - $\tan 60^\circ$  or  $\cot 30^\circ$
  - $-\sec 60^\circ$  or  $-\operatorname{cosec} 30^\circ$
- 

$\angle A$	$0^\circ$	$30^\circ$	$45^\circ$	$60^\circ$	$90^\circ$	$120^\circ$	$135^\circ$	$150^\circ$	$180^\circ$	$210^\circ$	$225^\circ$	$240^\circ$	$270^\circ$	$300^\circ$	$315^\circ$	$330^\circ$	$360^\circ$
SinA	0	1/2	1/√2	√3/2	1	√3/2	1/√2	1/2	0	-1/2	-1/√2	-√3/2	-1	-√3/2	-1/√2	-1/2	0
CosA	1	√3/2	1/√2	1/2	0	-1/2	-1/√2	-√3/2	-1	-√3/2	-1/√2	-1/2	0	1/2	1/√2	√3/2	1
TanA	0	1/√3	1	√3	ND	-√3	-1	-1/√3	0	1/√3	1	√3	ND	-√3	-1	-1/√3	0
CosecA	ND	2	√2	2√3	1	2/√3	√2	2	ND	-2	-√2	-2/√3	-1	-2/√3	-√2	-2	ND
SecA	1	2/√3	√2	2	ND	-2	-√2	-2/√3	-1	-2/√3	-√2	-2	ND	2	√2	2/√3	1
CotA	ND	√3	1	1/√3	0	-1/√3	-1	-√3	ND	√3	1	1/√3	0	-1/3	-1	-√3	ND

**TEXTUAL EXERCISE-2 (OBJECTIVE)**

- Which one of the following is possible?
  - $\sin \theta = \frac{a^2 + b^2}{a^2 - b^2}, (a \neq b)$
  - $\sec \theta = 4/5$
  - $\tan \theta = 45$
  - $\cos \theta = 7/3$
- $\triangle ABC$  is right angled at  $C$ , then  $\tan A + \tan B$  is equal to
  - $\frac{b^2}{ac}$
  - $a + b$
  - $\frac{a^2}{bc}$
  - $\frac{c^2}{ab}$

3.  $\sin^2 17.5^\circ + \sin^2 72.5^\circ$  is equal to  
 (a)  $\cos^2 90^\circ$   
 (b)  $\tan^2 45^\circ$   
 (c)  $\cos^2 30^\circ$   
 (d)  $\sin^2 45^\circ$
4. The value of expression  $\cos 1^\circ \cdot \cos 2^\circ \dots \cos 179^\circ$  equals  
 (a) 0 (b) 1  
 (c)  $1/\sqrt{2}$  (d) -1
5.  $\sin^2 5^\circ + \sin^2 10^\circ + \sin^2 15^\circ + \dots + \sin^2 90^\circ$  is equal to  
 (a)  $8\frac{1}{2}$  (b) 9  
 (c)  $9\frac{1}{2}$  (d)  $4\frac{1}{2}$
6. The value of  $\cos^2 \frac{\pi}{16} + \cos^2 \frac{3\pi}{16} + \cos^2 \frac{5\pi}{16} + \cos^2 \frac{7\pi}{16}$  is  
 (a) 2 (b) 1  
 (c) 0 (d) None of these
7.  $3(\sin x - \cos x)^4 + 6(\sin x + \cos x)^2 + 4(\sin^6 x + \cos^6 x)$  is equal to  
 (a) 12 (b) 13  
 (c) 14 (d) 11
8. The value of  $\left(1 + \cos \frac{\pi}{6}\right)\left(1 + \cos \frac{\pi}{3}\right)\left(1 + \cos \frac{2\pi}{3}\right)\left(1 + \cos \frac{7\pi}{6}\right)$  is  
 (a)  $3/16$  (b)  $3/8$   
 (c)  $3/4$  (d)  $1/2$
9. The value of  $\cos 480^\circ \sin 150^\circ + \sin 60^\circ \cdot \cos 390^\circ$  is equal to  
 (a) 0 (b) 1  
 (c)  $1/2$  (d) -1
10.  $\sin 120^\circ \cos 150^\circ - \cos 240^\circ \sin 330^\circ$  is equal to  
 (a) 1 (b) -1  
 (c)  $2/3$  (d)  $-\left(\frac{\sqrt{3}+1}{4}\right)$
11. The value of  $\cos(270^\circ + \theta) \cdot \cos(90^\circ - \theta) - \sin(270^\circ - \theta) \cos \theta$  is  
 (a) 0 (b) -1  
 (c)  $1/2$  (d) 1
12. The value of the expression  $\sin^6 \theta + \cos^6 \theta + 3\sin^2 \theta \cdot \cos^2 \theta$  equals  
 (a) 0 (b) 2  
 (c) 3 (d) 1
13. For  $x \in \mathbb{R}$ ,  $3\cos(4x - 5) + 4$  lies in the interval  
 (a)  $[1, 7]$  (b)  $[4, 7]$   
 (c)  $[0, 7]$  (d)  $[2, 7]$
14. The value of  $\tan 1^\circ \tan 2^\circ \tan 3^\circ \dots \tan 89^\circ$  is equal to  
 (a) -1 (b) 2  
 (c)  $\pi/2$  (d) 1
15. If  $\cos x + \cos^2 x = 1$ , then the value of  $\sin^{12} x + 3\sin^{10} x + 3\sin^8 x + \sin^6 x - 1$  is equal to  
 (a) 2 (b) 1  
 (c) -1 (d) 0

## Answer Keys

1. (c)    2. (d)    3. (b)    4. (a)    5. (c)    6. (a)    7. (b)    8. (a)    9. (c)    10. (b)  
 11. (d)    12. (d)    13. (a)    14. (d)    15. (d)



## INTER-CONVERSION OF TRIGONOMETRIC RATIOS

It is possible to express trigonometric ratios in terms of any one of them.

To express all the trigonometrical ratios in terms of the sine:

Let  $\angle AOP$  be any angle  $\theta$ , the length  $OP$  be unity and let the corresponding length of  $MP$  be  $s$ .

$$\begin{aligned} \text{Then } OM &= \sqrt{OP^2 - MP^2} \\ &= \sqrt{1 - s^2} \end{aligned}$$

$$\text{Hence } \cos \theta = \frac{OM}{OP} = \sqrt{1 - s^2} = \sqrt{1 - \sin^2 \theta}$$

$$\tan \theta = \frac{MP}{OM} = \frac{s}{\sqrt{1 - s^2}} = \frac{\sin \theta}{\sqrt{1 - \sin^2 \theta}}$$

1.28 ➤ Trigonometry

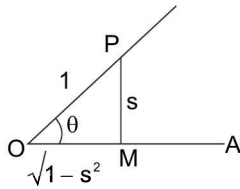

FIGURE 1.50

$$\cot \theta = \frac{OM}{MP} = \frac{\sqrt{1-s^2}}{s} = \frac{\sqrt{1-\sin^2 \theta}}{\sin \theta}$$

$$\operatorname{cosec} \theta = \frac{OP}{MP} = \frac{1}{s} = \frac{1}{\sin \theta} \text{ and}$$

$$\sec \theta = \frac{OP}{OM} = \frac{1}{\sqrt{1-s^2}} = \frac{1}{\sqrt{1-\sin^2 \theta}}$$

To express all the trigonometrical ratios in terms of the cotangent.

Taking the usual figure, let the length  $MP$  be unity, and let the corresponding value of  $OM$  be  $x$ .

$$\text{Then } OP = \sqrt{OM^2 + MP^2} = \sqrt{1+x^2}$$

$$\text{Hence } \cot \theta = \frac{OM}{MP} = \frac{x}{1} = x$$

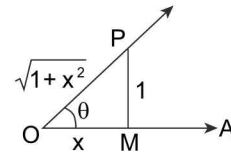

FIGURE 1.51

Therefore, we get

$$\sin \theta = \frac{MP}{OP} = \frac{1}{\sqrt{1+x^2}} = \frac{1}{\sqrt{1+\cot^2 \theta}}$$

$$\cos \theta = \frac{OM}{OP} = \frac{x}{\sqrt{1+x^2}} = \frac{\cot \theta}{\sqrt{1+\cot^2 \theta}}$$

$$\tan \theta = \frac{MP}{OM} = \frac{1}{x} = \frac{1}{\cot \theta}$$

$$\sec \theta = \frac{OP}{OM} = \frac{\sqrt{1+x^2}}{x} = \frac{\sqrt{1+\cot^2 \theta}}{\cot \theta} \text{ and}$$

$$\operatorname{cosec} \theta = \frac{OP}{MP} = \frac{\sqrt{1+x^2}}{1} = \sqrt{1+\cot^2 \theta}$$

Similarly, we can express all trigonometric functions in other trigonometric ratios.

	$\sin \theta$	$\cos \theta$	$\tan \theta$	$\cot \theta$	$\sec \theta$	$\operatorname{cosec} \theta$
$\sin \theta$	$\sin \theta$	$\sqrt{1-\cos^2 \theta}$	$\frac{\tan \theta}{\sqrt{1+\tan^2 \theta}}$	$\frac{1}{\sqrt{1+\cot^2 \theta}}$	$\frac{\sqrt{\sec^2 \theta - 1}}{\sec \theta}$	$\frac{1}{\operatorname{cosec} \theta}$
$\cos \theta$	$\sqrt{1-\sin^2 \theta}$	$\cos \theta$	$\frac{1}{\sqrt{1+\tan^2 \theta}}$	$\frac{\cot \theta}{\sqrt{1+\cot^2 \theta}}$	$\frac{1}{\sec \theta}$	$\frac{\sqrt{\operatorname{cosec}^2 \theta - 1}}{\operatorname{cosec} \theta}$
$\tan \theta$	$\frac{\sin \theta}{\sqrt{1-\sin^2 \theta}}$	$\frac{\sqrt{1-\cos^2 \theta}}{\cos \theta}$	$\tan \theta$	$\frac{1}{\cot \theta}$	$\sqrt{\sec^2 \theta - 1}$	$\frac{1}{\sqrt{\operatorname{cosec}^2 \theta - 1}}$
$\cot \theta$	$\frac{\sqrt{1-\sin^2 \theta}}{\sin \theta}$	$\frac{\cos \theta}{\sqrt{1-\cos^2 \theta}}$	$\frac{1}{\tan \theta}$	$\cot \theta$	$\frac{1}{\sqrt{\sec^2 \theta - 1}}$	$\sqrt{\operatorname{cosec}^2 \theta - 1}$
$\sec \theta$	$\frac{1}{\sqrt{1-\sin^2 \theta}}$	$\frac{1}{\cos \theta}$	$\sqrt{1+\tan^2 \theta}$	$\frac{\sqrt{1+\cot^2 \theta}}{\cot \theta}$	$\sec \theta$	$\frac{\operatorname{cosec} \theta}{\sqrt{\operatorname{cosec}^2 \theta - 1}}$
$\operatorname{cosec} \theta$	$\frac{1}{\sin \theta}$	$\frac{1}{\sqrt{1-\cos^2 \theta}}$	$\frac{\sqrt{1+\tan^2 \theta}}{\tan \theta}$	$\sqrt{1+\cot^2 \theta}$	$\frac{\sec \theta}{\sqrt{\sec^2 \theta - 1}}$	$\operatorname{cosec} \theta$

**ILLUSTRATION 11:** If  $\cos \theta$  equal  $3/5$ , find the magnitudes of the other ratios.

**SOLUTION:** Along the initial line  $OA$  take  $OM$  equal to 3 and construct a perpendicular  $MP$ . Let a line  $OP$  of length 5, revolve round  $O$  until its other end meets this perpendicular in the point  $P$ . Then  $\angle AOP$  is the angle  $\theta$ .

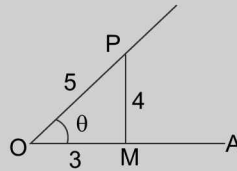

**FIGURE 1.52**

By geometry  $MP = \sqrt{OP^2 - OM^2} = \sqrt{5^2 - 3^2} = 4$

Hence  $\sin \theta = 4/5$ ,  $\tan \theta = 4/3$ ,  $\cot \theta = 3/4$ ,  $\operatorname{cosec} \theta = 5/4$ , and  $\sec \theta = 5/3$

### TEXTUAL EXERCISE-9 (SUBJECTIVE)

- Supposing  $\theta$  to be an angle whose  $\sin \theta$  is  $1/3$ , to find the magnitude of the other trigonometrical ratios.
- If  $\tan \theta = \frac{1}{\sqrt{7}}$ , find the value of  $\frac{\operatorname{cosec}^2 \theta - \sec^2 \theta}{\operatorname{cosec}^2 \theta + \sec^2 \theta}$
- If  $\tan^2 \theta + \sec \theta = 5$ , then find  $\cos \theta$
- If  $\tan \theta + \cot \theta = 2$ , then find  $\sin \theta$ .
- If  $\sec^2 \theta = 2 + \tan \theta$ , then find  $\tan \theta$ .

### Answer Keys

- $\cos \theta = \frac{2\sqrt{2}}{3}$ ,  $\tan \theta = \frac{1}{2\sqrt{2}}$ ,  $\cot \theta = 2\sqrt{2}$ ,  $\operatorname{cosec} \theta = 3$ ,  $\sec \theta = \frac{3}{2\sqrt{2}}$
- $3/4$       3.  $1/2$  or  $-1/3$       4.  $\frac{1}{\sqrt{2}}$       5.  $\frac{1 \pm \sqrt{5}}{2}$

### TEXTUAL EXERCISE-3 (OBJECTIVE)

- In a  $\triangle ABC$ ,  $\angle A = \pi/2$ , then  $\cos^2 B + \cos^2 C$  equals.
  - $-2$
  - $-1$
  - $1$
  - $0$
- The value of  $\frac{\cot 54^\circ}{\tan 36^\circ} + \frac{\tan 20^\circ}{\cot 70^\circ}$  is
  - $0$
  - $2$
  - $3$
  - $1$
- If  $\sum_{i=1}^n \sin \theta_i = n$ , then the value of  $\sum_{i=1}^n \cos \theta_i$  is
  - $n$
  - $0$
  - $1$
  - None of these
- The equation  $(a + b)^2 = 4ab \sin^2 \theta$  is possible only when
  - $2a = b$
  - $a = b$
  - $a = 2b$
  - None of these
- $\log \tan 1^\circ + \log \tan 2^\circ + \dots + \log \tan 89^\circ$  is
  - $1$
  - $0$
  - $\pi/4$
  - None of these
- The value of  $2(\sin^6 \theta + \cos^6 \theta) - 3(\sin^4 \theta + \cos^4 \theta) + 1$  is
  - $2$
  - $0$
  - $4$
  - $6$

1.30 > Trigonometry

7. If  $S_n = \cos^n \theta + \sin^n \theta$ , then the value of  $3S_4 - 2S_6$  is given by  
 (a) 4 (b) 0  
 (c) 1 (d) 7
8. If  $\frac{\cos A}{3} = \frac{\cos B}{4} = \frac{1}{5}$ ,  $-\frac{\pi}{2} < (A, B) < 0$ , then value of  $2 \sin A + 4 \sin B$  is  
 (a) 4 (b) -2  
 (c) -4 (d) 0
9. If  $\sec \theta = m$  and  $\tan \theta = n$ , then  $\frac{1}{m} \left[ (m+n) + \frac{1}{(m+n)} \right]$  is  
 (a) 2 (b)  $2m$   
 (c)  $2n$  (d)  $mn$
10. If  $\cos \theta = -\frac{\sqrt{3}}{2}$  and  $\sin \alpha = -\frac{\sqrt{3}}{5}$ , where  $\theta$  does not lie in the third quadrant, then  $25 \cos^2 \alpha + \sqrt{3} \tan \theta$  is equal to  
 (a) 22 (b) 21  
 (c) 23 (d) None of these
11. The value of  $\cos^4 \left( \frac{\pi}{8} \right) + \cos^4 \left( \frac{3\pi}{8} \right) + \cos^4 \left( \frac{5\pi}{8} \right) + \cos^4 \left( \frac{7\pi}{8} \right)$  is  
 (a) 0 (b)  $1/2$   
 (c)  $3/2$  (d) 1
12. If  $12 \cot^2 \theta - 31 \operatorname{cosec} \theta + 32 = 0$ , then the value of  $\sin \theta$  is  
 (a)  $3/4$  or  $1$  (b)  $2/3$  or  $-2/3$   
 (c)  $4/5$  or  $3/4$  (d)  $\pm 1/2$
13.  $\frac{\tan A}{1 + \sec A} + \frac{1 + \sec A}{\tan A}$  is equal to  
 (a)  $2 \sin A$  (b)  $2 \cos A$   
 (c)  $2 \operatorname{cosec} A$  (d)  $2 \sec A$

**Answer Keys**

1. (c) 2. (b) 3. (b) 4. (b) 5. (b) 6. (b) 7. (c) 8. (c) 9. (a) 10. (b)  
 11. (c) 12. (c) 13. (c)

**FORMULAE ON TRIGONOMETRIC RATIOS OF COMPOUND ANGLES**

An angle made up of the algebraic sum of two or more angles is called a **compound angle**. Let us discuss some of the standard formulae and results of the compound angles:

□  $\sin(A + B) = \sin A \cos B + \cos A \sin B$

**Proof:** Trigonometrical expansion does not follow the distributive law. Now, let us try to establish the above trigonometrical identity. Let  $\angle VOX = A$  and  $\angle TOV = B$ . Let  $P$  be any point on  $OT$ . Draw  $PM$  perpendicular to  $OX$  and  $PQ$  perpendicular to  $OV$  and  $QN$  perpendicular to  $OX$ . Also draw  $QR$  perpendicular to  $PM$ .

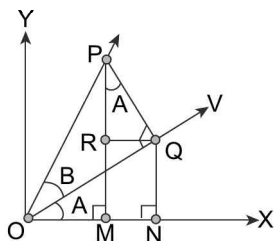

FIGURE 1.53

$\therefore \angle POM = A + B$

From the given diagram it is clear that  $\angle RPQ = A$

now  $\sin(A + B) = \sin \angle POM = \frac{MP}{OP} = \frac{MR + RP}{OP} =$

$\frac{QN}{OP} + \frac{RP}{OP} = \frac{QN}{OQ} \cdot \frac{OQ}{OP} + \frac{RP}{PQ} \cdot \frac{PQ}{OP}$

(Multiplying and dividing by  $OQ$  and  $PQ$  respectively)

$= \sin A \cos B + \cos A \sin B$

Hence  $\sin(A + B) = \sin A \cos B + \cos A \sin B$

Similarly, an expression can be developed for sine of the difference of angles  $(A - B)$

□  $\sin(A - B) = \sin A \cos B - \cos A \sin B$

$\sin(A + (-B))$  i.e., replacing  $B$  by  $(-B)$

$\Rightarrow \sin(A - B) = \sin(A + (-B)) = \sin A \cos(-B) + \cos A \sin(-B)$

$\Rightarrow \sin(A - B) = \sin A \cos B - \cos A \sin B.$

□  $\cos(A + B) = \cos A \cos B - \sin A \sin B:$

Consider the unit circle with centre At the origin (fig.). Let  $A$  be the Angle  $P_4OP_1$  and  $B$  be the angle  $P_1OP_2$ . Then  $(A + B)$  is the angle  $P_4OP_2$ . also let  $(-B)$  be the angle  $P_4OP_3$ . Therefore  $P_1, P_2$  and  $P_4$  will have the coordinates  $P_1(\cos A, \sin A), P_2(\cos(A + B), \sin(A + B)), P_3(\cos(-B), \sin(-B))$  and  $P_4(1,0)$ .

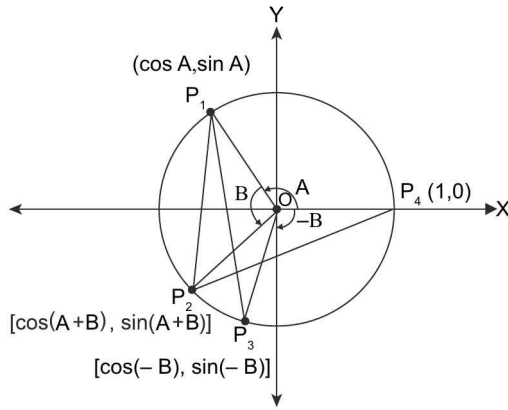

FIGURE 1.54

By SAS congruency, we get  $\Delta P_1OP_3 \cong \Delta P_2OP_4$ . Therefore,  $P_1P_3$  and  $P_2P_4$  are equal. By using the distance formula, we get

$$\begin{aligned} P_1P_3^2 &= [\cos A - \cos(-B)]^2 + [\sin A - \sin(-B)]^2 \\ &= (\cos A - \cos B)^2 + (\sin A + \sin B)^2 \text{ [using } \cos(-B) \\ &= \cos B \text{ and } \sin(-B) = -\sin B] \\ &= \cos^2 A + \cos^2 B - 2\cos A \cos B + \sin^2 A + \sin^2 B + \\ &\quad 2\sin A \sin B \\ &= 2 - 2(\cos A \cos B - \sin A \sin B) \end{aligned}$$

$$\begin{aligned} \text{Also } P_2P_4^2 &= [1 - \cos(A+B)]^2 + [0 - \sin(A+B)]^2 \\ &= 1 - 2\cos(A+B) + \cos^2(A+B) + \sin^2(A+B) \\ &= 2 - 2\cos(A+B). \end{aligned}$$

Since  $P_1P_3 = P_2P_4$ , we have  $P_1P_3^2 = P_2P_4^2$ .

$$\begin{aligned} \text{Therefore } 2 - 2(\cos A \cos B - \sin A \sin B) \\ &= 2 - 2\cos(A+B). \end{aligned}$$

**Hence**  $\cos(A+B) = \cos A \cos B - \sin A \sin B$ .

Therefore replacing  $B$  by  $-B$ , we get

$$\square \cos(A-B) = \cos A \cos B + \sin A \sin B.$$

Replacing  $B$  by  $-B$ , we get the desired result.

**Aliter:** The result of the sine, cosine and tangent of compound angle can also be derived using the concept of complex numbers as discussed below:

$$\begin{aligned} \cos(A \pm B) + i \sin(A \pm B) &= e^{i(A \pm B)} = e^{iA} e^{\pm iB} \\ &= (\cos A + i \sin A) \cdot (\cos B \pm i \sin B) \\ &= (\cos A \cos B \mp \sin A \sin B) + i(\sin A \cos B \pm \cos A \sin B) \end{aligned}$$

Comparing the real and imaginary parts of the left and right hand side, we obtain

$$\cos(A \pm B) = (\cos A \cos B \mp \sin A \sin B) \quad \dots(i)$$

$$\text{and } \sin(A \pm B) = (\sin A \cos B \pm \cos A \sin B) \quad \dots(ii)$$

$$\square \tan(A \pm B) = \frac{\sin(A \pm B)}{\cos(A \pm B)} = \frac{\sin A \cos B \pm \cos A \sin B}{\cos A \cos B \mp \sin A \sin B}$$

Dividing  $N^r$  and  $D^r$  by  $\cos A \cos B$ , we get

$$\tan(A \pm B) = \frac{\tan A \pm \tan B}{1 \mp \tan A \tan B}.$$

$$\text{Similarly, } \cot(A \pm B) = \frac{\cot A \cot B \mp 1}{\cot B \pm \cot A}$$

**Corollary:** In the above results, we can also get the trigonometrical functions of the multiple angles like  $2A$  by replacing  $B$  by  $A$ .

$$\therefore \sin 2A = \sin A \cos A + \cos A \sin A = 2\sin A \cos A$$

now multiplying  $N^r$  and  $D^r$  by  $\frac{1}{\cos^2 A}$ , we get

$$\sin 2A = \frac{2 \frac{\sin A \cos A}{\cos^2 A}}{\frac{1}{\cos^2 A}} = \frac{2 \tan A}{\sec^2 A} = \frac{2 \tan A}{1 + \tan^2 A}$$

$$\begin{aligned} \text{and } \cos 2A &= \cos A \cos A - \sin A \sin A \\ &= \cos^2 A - \sin^2 A = 2 \cos^2 A - 1 \\ &= 1 - 2 \sin^2 A \end{aligned}$$

$$\Rightarrow \cos 2A = \cos^2 A - \sin^2 A$$

Multiplying  $N^r$  and  $D^r$  of R.H.S. by  $\frac{1}{\cos^2 A}$ , we get

$$\begin{aligned} \cos 2A &= \frac{1 - \tan^2 A}{1 + \tan^2 A} \\ \Rightarrow \tan 2A &= \frac{\tan A + \tan A}{1 - \tan^2 A} = \frac{2 \tan A}{1 - \tan^2 A} \text{ where} \end{aligned}$$

$$A \neq (2n+1)\frac{\pi}{4}.$$

$\square$  **Trigonometric functions of '3A'**

$$\begin{aligned} \sin 3A &= \sin(2A + A) \\ &= \sin 2A \cos A + \cos 2A \sin A \\ &= 2 \sin A \cos^2 A + (1 - 2\sin^2 A) \sin A \\ &= 2 \sin A (1 - \sin^2 A) + \sin A - 2\sin^3 A \\ &= 3 \sin A - 4 \sin^3 A. \end{aligned}$$

**Similarly,**  $\cos 3A = 4 \cos^3 A - 3 \cos A$

$$\begin{aligned} \tan 3A &= \frac{\sin 3A}{\cos 3A} = \frac{3 \sin A - 4 \sin^3 A}{4 \cos^3 A - 3 \cos A} \\ &= \tan A \left( \frac{3 - 4 \sin^2 A}{4 \cos^2 A - 3} \right) \end{aligned}$$



1.32 > Trigonometry

Dividing  $N^r$  and  $D^r$  by  $\cos^2 A$ , we get  $\frac{3 \tan A - 4 \tan^3 A}{1 - 3 \tan^2 A}$   
 where  $A \neq (2n + 1) \pi/6$ .

**Multiple Angle Results in the General Form**

From the Demoiivre's theorem,  $\cos n\alpha + i \sin n\alpha = (\cos \alpha + i \sin \alpha)^n$  for any integer  $n$ . ....(i)

Binomically expanding the the equation, we get  $(\cos \alpha + i \sin \alpha)^n = {}^nC_0 \cos^n \alpha + {}^nC_1 i \cos^{n-1} \alpha \sin \alpha + {}^nC_2 i^2 \cos^{n-2} \alpha \sin^2 \alpha + {}^nC_3 i^3 \cos^{n-3} \alpha \sin^3 \alpha + \dots$  ....(ii)

Comparing the real and imaginary parts, we get

$$\cos n\alpha = {}^nC_0 \cos^n \alpha - {}^nC_2 \cos^{n-2} \alpha \sin^2 \alpha + {}^nC_4 \cos^{n-4} \alpha \sin^4 \alpha + \dots \dots \dots \text{.....(iii)}$$

$$\sin n\alpha = {}^nC_1 \cos^{n-1} \alpha \sin \alpha - {}^nC_3 \cos^{n-3} \alpha \sin^3 \alpha + {}^nC_5 \cos^{n-5} \alpha \sin^5 \alpha + \dots \dots \dots \text{.....(iv)}$$

Taking  $\cos^n \alpha$  common from the RHS of the above two equations, we obtain the following two identities:

$$\sin n\alpha = \cos^n \alpha ({}^nC_1 \tan \alpha - {}^nC_3 \tan^3 \alpha + {}^nC_5 \tan^5 \alpha \dots) \dots \dots \text{....(v)}$$

$$\cos n\alpha = \cos^n \alpha (1 - {}^nC_2 \tan^2 \alpha + {}^nC_4 \tan^4 \alpha - \dots) \dots \dots \text{....(vi)}$$

Dividing the relation (v) by (vi), we obtain

$$\tan n\alpha = \frac{{}^nC_1 \tan \alpha - {}^nC_3 \tan^3 \alpha + {}^nC_5 \tan^5 \alpha \dots}{1 - {}^nC_2 \tan^2 \alpha + {}^nC_4 \tan^4 \alpha - {}^nC_6 \tan^6 \alpha + \dots}$$

Adding and subtracting the equations (v) and (vi) we can also derive the following two identities

$$\sin n\alpha + \cos n\alpha = \cos^n \alpha (1 + {}^nC_1 \tan \alpha - {}^nC_2 \tan^2 \alpha - {}^nC_3 \tan^3 \alpha + {}^nC_4 \tan^4 \alpha + {}^nC_5 \tan^5 \alpha - {}^nC_6 \tan^6 \alpha \dots)$$

$$\sin n\alpha - \cos n\alpha = \cos^n \alpha (-1 + {}^nC_1 \tan \alpha + {}^nC_2 \tan^2 \alpha - {}^nC_3 \tan^3 \alpha - {}^nC_4 \tan^4 \alpha + {}^nC_5 \tan^5 \alpha + {}^nC_6 \tan^6 \alpha \dots)$$

**NOTE**

*These formulae will be used in finding trigonometric functions of submultiple angles in the chapter to come.*

**ILLUSTRATION 12:** If  $A + B = 45^\circ$ , then show that  $(1 + \tan A)(1 + \tan B) = 2$

**SOLUTION:**  $\therefore A + B = 45^\circ \therefore \tan(A + B) = \tan 45^\circ = 1 \Rightarrow \frac{\tan A + \tan B}{1 - \tan A \tan B} = 1$   
 $\Rightarrow \tan A + \tan B = 1 - \tan A \tan B \Rightarrow \tan A + \tan B + \tan A \tan B = 1$   
 $\Rightarrow \tan A (1 + \tan B) + \tan B + 1 = 2 \Rightarrow (1 + \tan B)(1 + \tan A) = 2$

**ILLUSTRATION 13:** Evaluate the following:

- (a)  $\sin 75^\circ$  (b)  $\cos 75^\circ$  (c)  $\tan 15^\circ$

**SOLUTION:** (a)  $\sin 75^\circ = \sin (45^\circ + 30^\circ) = \sin 45^\circ \cos 30^\circ + \cos 45^\circ \sin 30^\circ = \frac{1}{\sqrt{2}} \cdot \frac{\sqrt{3}}{2} + \frac{1}{\sqrt{2}} \cdot \frac{1}{2} = \frac{\sqrt{3} + 1}{2\sqrt{2}}$   
 (b)  $\cos 75^\circ = \cos (45^\circ + 30^\circ) = \cos 45^\circ \cos 30^\circ - \sin 45^\circ \sin 30^\circ = \frac{1}{\sqrt{2}} \left( \frac{\sqrt{3} - 1}{2} \right) = \frac{\sqrt{3} - 1}{2\sqrt{2}}$   
 (c)  $\tan 15^\circ = \tan (45^\circ - 30^\circ) = \frac{\tan 45^\circ - \tan 30^\circ}{1 + \tan 45^\circ \tan 30^\circ} = \frac{1 - 1/\sqrt{3}}{1 + 1/\sqrt{3}} = \frac{\sqrt{3} - 1}{\sqrt{3} + 1} = 2 - \sqrt{3}$

**ILLUSTRATION 14:** Prove that  $[\{\sin(x - y) \cos y + \cos(x - y) \sin y\} + \{\cos(x - y) \cos y - \sin(x - y) \sin y\}] \times [\{\sin(x - y) \cos y + \cos(x - y) \sin y\} - \{\cos(x - y) \cos y - \sin(x - y) \sin y\}] = -\cos 2x$

**SOLUTION:** Starting from bigger expression and applying compound angle results, we get;

$$\begin{aligned} \text{LHS} &= [\sin(x - y + y) + \cos(x - y + y)] [\sin(x - y + y) - \cos(x - y + y)] \\ &= (\sin x + \cos x)(\sin x - \cos x) = \sin^2 x - \cos^2 x = -\cos 2x \end{aligned}$$

**ILLUSTRATION 15:** Prove that  $\tan\left(\frac{\pi}{4} + \theta\right) \times \tan\left(\frac{3\pi}{4} + \theta\right) = -1$

**SOLUTION:** LHS =  $\tan\left(\frac{\pi}{4} + \theta\right) \times \tan\left(\frac{3\pi}{4} + \theta\right) = \frac{\tan(\pi/4) + \tan \theta}{1 - \tan(\pi/4) \tan \theta} \times \frac{\tan(3\pi/4) + \tan \theta}{1 - \tan(3\pi/4) \tan \theta}$

$$= \left(\frac{1 + \tan \theta}{1 - \tan \theta}\right) \left(\frac{-1 + \tan \theta}{1 + \tan \theta}\right) = -1$$

**ILLUSTRATION 16:** If  $\tan \theta = \frac{k}{k+1}$  and  $\tan \phi = \frac{1}{2k+1}$ , find  $\tan(\theta + \phi)$  and  $\tan(\theta - \phi)$

**SOLUTION:**  $\therefore \tan(\theta + \phi) = \frac{\tan \theta + \tan \phi}{1 - \tan \theta \tan \phi} = \frac{\frac{k}{k+1} + \frac{1}{2k+1}}{1 - \frac{k}{k+1} \cdot \frac{1}{2k+1}} = \frac{2k^2 + k + k + 1}{2k^2 + 3k + 1 - k} = 1$

and  $\tan(\theta - \phi) = \frac{\tan \theta - \tan \phi}{1 + \tan \theta \tan \phi} = \frac{\frac{k}{k+1} - \frac{1}{2k+1}}{1 + \frac{k}{k+1} \cdot \frac{1}{2k+1}} = \frac{2k^2 + k - k - 1}{2k^2 + 4k + 1} = \frac{2k^2 - 1}{2k^2 + 4k + 1}$

**ILLUSTRATION 17:** If  $2 \sin \alpha \cos \beta \sin \gamma = \sin \beta \sin(\alpha + \gamma)$ . Then show  $\tan \alpha$ ,  $\tan \beta$  and  $\tan \gamma$  are in Harmonic Progression.

**SOLUTION:**  $2 \sin \alpha \cos \beta \sin \gamma = \sin \beta \sin(\alpha + \gamma)$

or  $2 \sin \alpha \cos \beta \sin \gamma = \sin \beta \{\sin \alpha \cos \gamma + \cos \alpha \sin \gamma\}$

$\Rightarrow 2 \sin \alpha \cos \beta \sin \gamma = \sin \alpha \sin \beta \cos \gamma + \cos \alpha \sin \beta \sin \gamma$

Dividing both sides by  $\sin \alpha \cdot \sin \beta \cdot \sin \gamma$ , we get

$$2 \cot \beta = \cot \alpha + \cot \gamma \quad \text{or} \quad \frac{2}{\tan \beta} = \frac{1}{\tan \alpha} + \frac{1}{\tan \gamma}$$

i.e.,  $\frac{1}{\tan \alpha}, \frac{1}{\tan \beta}, \frac{1}{\tan \gamma}$  are in A.P. or  $\tan \alpha, \tan \beta, \tan \gamma$  are in H.P.

**ILLUSTRATION 18:** If  $3 \tan \theta \tan \phi = 1$ , then prove that  $2 \cos(\theta + \phi) = \cos(\theta - \phi)$

**SOLUTION:** Given that  $3 \tan \theta \tan \phi = 1$  or,  $\cot \theta \cot \phi = 3/1$  or  $\frac{\cos \theta \cos \phi}{\sin \theta \sin \phi} = \frac{3}{1}$

Using componendo and dividendo we have  $\frac{\cos \theta \cos \phi + \sin \theta \sin \phi}{\cos \theta \cos \phi - \sin \theta \sin \phi} = \frac{4}{2}$

$\Rightarrow \frac{\cos(\theta - \phi)}{\cos(\theta + \phi)} = 2$  or  $2 \cos(\theta + \phi) = \cos(\theta - \phi)$

**ILLUSTRATION 19:** Show that  $2 \cos \theta = \sqrt{2 + \sqrt{2 + 2 \cos 4\theta}}$  where  $-\pi/4 \leq \theta \leq \pi/4$

**SOLUTION:** RHS =  $\sqrt{2 + \sqrt{2 + 2 \cos 4\theta}} = \sqrt{2 + \sqrt{2(1 + \cos 4\theta)}}$

$$= \sqrt{2 + \sqrt{2(1 + 2 \cos^2 2\theta - 1)}} = \sqrt{2 + \sqrt{4 \cos^2 2\theta}}$$

$$= \sqrt{2 + 2 |\cos 2\theta|} = \sqrt{2(1 + \cos 2\theta)} \quad (\because \cos 2\theta \geq 0)$$

$$= \sqrt{2(1 + 2 \cos^2 \theta - 1)} = \sqrt{4 \cos^2 \theta} = 2 |\cos \theta| = 2 \cos \theta \quad (\because \cos \theta > 0)$$

**ILLUSTRATION 20:** Prove that  $\cos 5\alpha = 16\cos^5 \alpha - 20\cos^3 \alpha + 5\cos \alpha$

**SOLUTION:** We have  $\cos 5\alpha = \cos(3\alpha + 2\alpha)$

$$\begin{aligned} &= \cos 3\alpha \cos 2\alpha - \sin 3\alpha \sin 2\alpha \\ &= (4\cos^3 \alpha - 3\cos \alpha)(2\cos^2 \alpha - 1) - (3\sin \alpha - 4\sin^3 \alpha) \cdot 2\sin \alpha \cos \alpha \\ &= (8\cos^5 \alpha - 10\cos^3 \alpha + 3\cos \alpha) - 2\cos \alpha \sin^2 \alpha (3 - 4\sin^2 \alpha) \\ &= (8\cos^5 \alpha - 10\cos^3 \alpha + 3\cos \alpha) - 2\cos \alpha (1 - \cos^2 \alpha)(4\cos^2 \alpha - 1) \\ &= (8\cos^5 \alpha - 10\cos^3 \alpha + 3\cos \alpha) - 2\cos \alpha (5\cos^2 \alpha - 4\cos^4 \alpha - 1) \\ &= 16\cos^5 \alpha - 20\cos^3 \alpha + 5\cos \alpha \end{aligned}$$

**ILLUSTRATION 21:** Express  $\sin^5 \theta$  in the terms of  $\sin(n\theta)$ ;  $n \in \mathbb{N}$ .

**SOLUTION:**  $\sin \theta = \frac{1}{2i} \left( z - \frac{1}{z} \right)$  [using our knowledge of complex numbers  $z = \cos \theta + i \sin \theta$ ]

$$\begin{aligned} \Rightarrow \sin^5 \theta &= \frac{1}{32i^5} \left( z - \frac{1}{z} \right)^5 = \frac{1}{32i} \left( {}^5C_0 z^5 - {}^5C_1 z^3 + {}^5C_2 z - {}^5C_3 \left( \frac{1}{z} \right) + {}^5C_4 \left( \frac{1}{z} \right)^3 + {}^5C_5 \left( \frac{1}{z} \right)^5 \right) \\ &= \frac{1}{32i} \left\{ (\cos 5\theta + i \sin 5\theta) - 5(\cos 3\theta + i \sin 3\theta) + 10(\cos \theta + i \sin \theta) \right. \\ &\quad \left. - 10(\cos(-\theta) + i \sin(-\theta)) + 5(\cos(-3\theta) + i \sin(-3\theta)) - (\cos(-5\theta) + i \sin(-5\theta)) \right\} \\ &= \frac{1}{16} (\sin 5\theta - 5 \sin 3\theta + 10 \sin \theta). \end{aligned}$$

## TEXTUAL EXERCISE-10 (SUBJECTIVE)

1. Prove the following universal identities:

- (a)  $\frac{\sin(A-B)}{\cos A \cos B} + \frac{\sin(B-C)}{\cos B \cos C} + \frac{\sin(C-A)}{\cos C \cos A} = 0$
- (b)  $\cos \alpha \cos(\gamma - \alpha) - \sin \alpha \sin(\gamma - \alpha) = \cos \gamma$
- (c)  $\cos(\alpha + \beta) \cos \gamma - \cos(\beta + \gamma) \cos \alpha$   
 $= \sin \beta \sin(\gamma - \alpha)$
- (d)  $\sin(n+1)\theta \sin(n-1)\theta + \cos(n+1)\theta \cos(n-1)\theta$   
 $= \cos 2\theta$
- (e)  $\sin(n+1)\alpha \sin(n+2)\alpha + \cos(n+1)\alpha \cos(n+2)\alpha$   
 $= \cos \alpha$

2. Prove that:

- (a)  $\cot\left(\frac{\pi}{4} + \theta\right) \times \cot\left(\frac{\pi}{4} - \theta\right) = 1.$
- (b)  $1 + \tan \theta \tan \frac{\theta}{2} = \tan \theta \cot \frac{\theta}{2} - 1 = \sec \theta$

3. Prove that  $\cos(60^\circ - A) \cos A \cos(60^\circ + A) = \frac{1}{4} \cos 3A.$

4. Prove that  $\tan(60^\circ - A) \tan A \tan(60^\circ + A) = \tan 3A.$

5. Find the expression  $\cos^7 \theta$  in the terms of  $\cos n\theta$ ;  $n \in \mathbb{N}$ .

## Answer Key

5.  $\frac{1}{64} (\cos 7\theta + 7 \cos 5\theta + 21 \cos 3\theta + 35 \cos \theta)$

**A few more results can be derived using the theory just covered**

$$1. \sin(A+B)\sin(A-B) = \sin^2 A - \sin^2 B = \cos^2 B - \cos^2 A$$

**Proof:** This result can be obtained from compound formulae

$$\begin{aligned} &= (\sin A \cos B + \cos A \sin B)(\sin A \cos B - \cos A \sin B) \\ &= \sin^2 A \cos^2 B - \cos^2 A \sin^2 B \\ &= \sin^2 A (1 - \sin^2 B) - (1 - \sin^2 A) (\sin^2 B) \\ &= \sin^2 A - \sin^2 A \sin^2 B - \sin^2 B + \sin^2 A \sin^2 B \\ &= \sin^2 A - \sin^2 B \end{aligned} \quad \dots(i)$$

which is also equal to  $1 - \cos^2 A - 1 + \cos^2 B$   
 $= \cos^2 B - \cos^2 A \quad \dots(ii)$

$$2. \cos(A+B)\cos(A-B) = \cos^2 A - \sin^2 B = \cos^2 B - \sin^2 A$$

**Proof:**

$$\begin{aligned} &= (\cos A \cos B - \sin A \sin B)(\cos A \cos B + \sin A \sin B) \\ &= \cos^2 A \cos^2 B - \sin^2 A \sin^2 B \\ &= \cos^2 A (1 - \sin^2 B) - (1 - \cos^2 A) \sin^2 B \\ &= \cos^2 A - \cos^2 A \sin^2 B - \sin^2 B + \sin^2 B \cos^2 A \\ &= \cos^2 A - \sin^2 B \end{aligned}$$

which is equal to  $1 - \sin^2 A - 1 + \cos^2 B = \cos^2 B - \sin^2 A$

$$3. 1 + \cos 2A = 2\cos^2 A; 1 - \cos 2A = 2\sin^2 A$$

$$4. \frac{1 - \cos 2A}{\sin 2A} = \tan A; \text{ where } A \neq \frac{n\pi}{2}; n \in \mathbb{Z}$$

$$5. \frac{1 + \cos 2A}{\sin 2A} = \cot A; \text{ where } A \neq \frac{n\pi}{2}; n \in \mathbb{Z}$$

$$6. \frac{1 - \cos 2A}{1 + \cos 2A} = \tan^2 A; \text{ where } A \neq (2n+1)\frac{\pi}{2}; n \in \mathbb{Z}$$

$$7. \frac{1 + \cos 2A}{1 - \cos 2A} = \cot^2 A; \text{ where } A \neq n\pi; n \in \mathbb{Z}$$

$$8. \sin^3 A = \frac{3\sin A - \sin 3A}{4}; A \in \mathbb{R}$$

$$9. \cos^3 A = \frac{3\cos A + \cos 3A}{4}; A \in \mathbb{R}$$

**Using these formulae, we can also find the formulae for the sub-multiple angles**

$$1 + \cos A = 2\cos^2 A/2 \Rightarrow \cos A/2 = \pm \sqrt{\frac{1 + \cos A}{2}}$$

$$1 - \cos A = 2\sin^2 A/2 \Rightarrow \sin A/2 = \pm \sqrt{\frac{1 - \cos A}{2}}$$

$$\cos A = \frac{1 - \tan^2 A/2}{1 + \tan^2 A/2} \Rightarrow \tan A/2 = \pm \sqrt{\frac{1 - \cos A}{1 + \cos A}}$$

**Intercept Application of Submultiple of an Angle**

$$1. \left| \sin \frac{A}{2} + \cos \frac{A}{2} \right| = \sqrt{1 + \sin A}$$

or  $\sin A/2 + \cos A/2 = \pm \sqrt{1 + \sin A}$

$$\text{i.e., } \begin{cases} +, & \text{if } 2n\pi - \frac{\pi}{4} \leq \frac{A}{2} \leq 2n\pi + \frac{3\pi}{4} \\ -, & \text{otherwise} \end{cases}$$

$$2. \left| \sin \frac{A}{2} - \cos \frac{A}{2} \right| = \sqrt{1 - \sin A}$$

or  $\left( \sin \frac{A}{2} - \cos \frac{A}{2} \right) = \pm \sqrt{1 - \sin A}$

$$\text{i.e., } \begin{cases} +, & \text{if } 2n\pi + \frac{\pi}{4} \leq \frac{A}{2} \leq 2n\pi + \frac{5\pi}{4} \\ -, & \text{otherwise} \end{cases}$$

$$3. \tan A/2 = \frac{\pm \sqrt{\tan^2 A + 1} - 1}{\tan A}, \text{ the ambiguities of signs are removed by locating the quadrants in which } A/2.$$

**NOTES**

(i) Any formula that gives the value of  $\sin A/2$  in terms of  $\sin A$  will also give the value of sine of  $\left( \frac{2n\pi + (-1)^n A}{2} \right)$ .

(ii) Any formula that gives the value of  $\cos A/2$  in terms of  $\cos A$  will also give the value of cosine of  $\left( \frac{4n\pi \pm A}{2} \right)$ .

(iii) Any formula that gives the value of  $\tan A/2$  in terms of  $\tan A$  will also give the value of tangent of  $\left( \frac{2n\pi + A}{2} \right)$ .

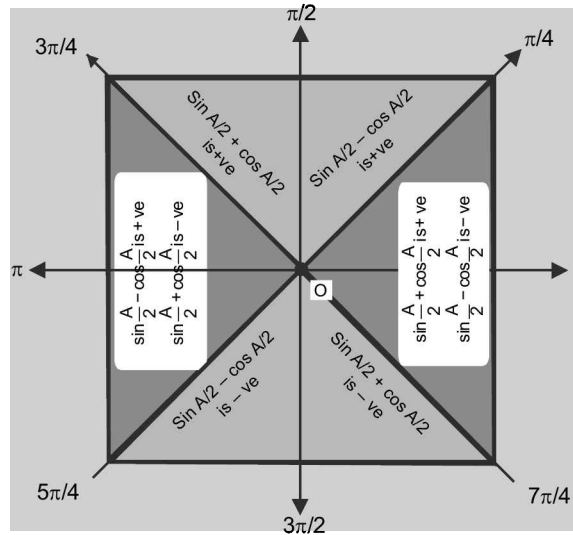

FIGURE 1.55

**ILLUSTRATION 22:** Find the values of  $\sin 18^\circ$ .

**SOLUTION:** Let  $\theta = 18^\circ \therefore 5\theta = 90^\circ \Rightarrow 2\theta + 3\theta = 90^\circ \Rightarrow 2\theta = 90^\circ - 3\theta$

Taking sine on both sides, we get  $2\sin\theta \cos\theta = 4\cos^3\theta - 3\cos\theta$

Dividing both sides by  $\cos\theta$  [ $\because \cos\theta = \cos 18^\circ \neq 0$ ]

$$\Rightarrow 2\sin\theta = 4\cos^2\theta - 3 \Rightarrow 2\sin\theta = 4(1 - \sin^2\theta) - 3$$

$$\Rightarrow 2\sin\theta = 1 - 4\sin^2\theta \Rightarrow 4\sin^2\theta + 2\sin\theta - 1 = 0$$

It is a quadratic equation in  $\sin\theta$ ,

$$\therefore \sin\theta = \frac{-2 \pm \sqrt{4+16}}{8} = \frac{-2 \pm 2\sqrt{5}}{8} = \frac{-1 \pm \sqrt{5}}{4}$$

But  $\sin\theta = \frac{\sqrt{5}-1}{4}$  (positive) or  $\sin\theta = \frac{-1-\sqrt{5}}{4}$  (negative)

Now  $\theta = 18^\circ$  lies in the first quadrant. So  $\sin\theta$  is positive

Therefore rejecting the negative value, we get  $\sin\theta = \frac{\sqrt{5}-1}{4}$ , 1

**ILLUSTRATION 23:** Evaluate the following  $\sin 22\frac{1}{2}^\circ$  and  $\cos 22\frac{1}{2}^\circ$ .

**SOLUTION:** Let  $22\frac{1}{2}^\circ = \theta$ ,  $2\cos^2\theta - 1 = \cos 2\theta$

$$\Rightarrow \cos^2\theta = \frac{1 + \cos 2\theta}{2} = \frac{1 + \cos 45^\circ}{2} = \frac{\sqrt{2} + 1}{2\sqrt{2}}$$

$$\Rightarrow \cos\theta = \cos\left(22\frac{1}{2}\right)^\circ = \sqrt{\frac{\sqrt{2}+1}{2\sqrt{2}}}$$

$$\text{Similarly } \sin\theta = \sqrt{\frac{1-\cos 45^\circ}{2}} = \sqrt{\frac{\sqrt{2}-1}{2\sqrt{2}}}$$

**ILLUSTRATION 24:** Find the value of  $\frac{\sqrt{1+\sin 2A} + \sqrt{1-\sin 2A}}{\sqrt{1+\sin 2A} - \sqrt{1-\sin 2A}}$  when  $|\tan A| < 1$  and  $|A|$  is acute.

**SOLUTION:** Given expression is  $\frac{\sqrt{1+\sin 2A} + \sqrt{1-\sin 2A}}{\sqrt{1+\sin 2A} - \sqrt{1-\sin 2A}}$

$$\Rightarrow \frac{\sqrt{(\cos A + \sin A)^2} + \sqrt{(\cos A - \sin A)^2}}{\sqrt{(\cos A + \sin A)^2} - \sqrt{(\cos A - \sin A)^2}}$$

$$\Rightarrow \frac{|\cos A + \sin A| + |\cos A - \sin A|}{|\cos A + \sin A| - |\cos A - \sin A|} = \frac{\cos A + \sin A + \cos A - \sin A}{\cos A + \sin A - (\cos A - \sin A)}$$

$\{\because -\pi/4 < A < \pi/4 \text{ and in this interval } \cos A > \sin A\}$

$$= \frac{2\cos A}{2\sin A} = \cot A \Rightarrow \frac{\sqrt{1+\sin 2A} + \sqrt{1-\sin 2A}}{\sqrt{1+\sin 2A} - \sqrt{1-\sin 2A}} = \cot A$$

when  $|\tan A| < 1$  and  $|A|$  is acute

**ILLUSTRATION 25:** Find  $\frac{A}{2}$  if it satisfy,  $2\sin \frac{A}{2} = \sqrt{1+\sin A} + \sqrt{1-\sin A}$ .

**SOLUTION:**  $2\sin \frac{A}{2} = \sqrt{1+\sin A} + \sqrt{1-\sin A}$  when  $\sin \frac{A}{2} + \cos \frac{A}{2} = \sqrt{1+\sin A}$  and  $\sin \frac{A}{2} - \cos \frac{A}{2} = \sqrt{1-\sin A}$

i.e., when  $\sin \frac{A}{2}$  is positive and  $\sin \frac{A}{2} \geq \pm \cos \frac{A}{2}$

i.e., when  $\frac{A}{2}$  lies between,  $2n\pi + \frac{\pi}{4} < \frac{A}{2} < 2n\pi + \frac{3\pi}{4}$ ;  $n \in \mathbb{Z}$

$$\therefore \frac{A}{2} \in \left(2n\pi + \frac{\pi}{4}, 2n\pi + \frac{3\pi}{4}\right)$$

**ILLUSTRATION 26:** Find  $A/2$  if it satisfy,  $2\cos \frac{A}{2} = \sqrt{1+\sin A} + \sqrt{1-\sin A}$

**SOLUTION:** Given is  $2\cos \frac{A}{2} = \sqrt{1+\sin A} + \sqrt{1-\sin A}$

when,  $\sin \frac{A}{2} + \cos \frac{A}{2} = \sqrt{1+\sin A}$  and  $\sin \frac{A}{2} - \cos \frac{A}{2} = \sqrt{1-\sin A}$

i.e., when  $\cos A/2 > 0$  and  $\cos \frac{A}{2} \geq \pm \sin \frac{A}{2}$

$$\Rightarrow 2n\pi - \frac{\pi}{4} < \frac{A}{2} < 2n\pi + \frac{\pi}{4} \Rightarrow \frac{A}{2} \in \left(2n\pi - \frac{\pi}{4}, 2n\pi + \frac{\pi}{4}\right) n \in \mathbb{Z}$$

**TEXTUAL EXERCISE-11 (SUBJECTIVE)**

1. Prove the following:

(i)  $\cos 18^\circ = \frac{\sqrt{10+2\sqrt{5}}}{4}$     (ii)  $\sin 36^\circ = \frac{\sqrt{10-2\sqrt{5}}}{4}$

(iii)  $\cos 36^\circ = \frac{\sqrt{5}+1}{4}$

2. If  $\cos(x - y)$ ,  $\cos x$  and  $\cos(x + y)$  are in Harmonic Progression, then evaluate  $|\cos x \cdot \sec y/2|$ .

3. If  $\cos \alpha = \frac{1}{2} \left( x + \frac{1}{x} \right)$ ,  $\cos \beta = \frac{1}{2} \left( y + \frac{1}{y} \right)$ , then evaluate  $\cos(\alpha - \beta)$

4. In the  $x - y$  plane consider the unit circle (centre  $O$ , radius = 1) and take two points  $P = (\cos A, \sin A)$  and  $Q = (\cos B, \sin B)$  on the circle as shown in the figure. Use the distance formula for  $PQ$  in two ways to obtain  $\cos(A - B) = \cos A \cos B + \sin A \sin B$ .

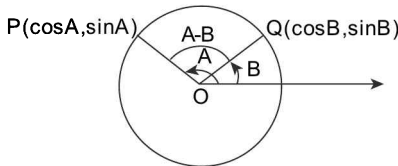

FIGURE 1.56

5. Prove the following identities:

(a)  $\frac{\sec 8\theta - 1}{\sec 4\theta - 1} = \frac{\tan 8\theta}{\tan 2\theta}$

(b)  $\frac{\sin^2 \alpha - \sin^2 \beta}{\sin \alpha \cos \alpha - \sin \beta \cos \beta} = \tan(\alpha + \beta)$

(c)  $\frac{\cos A + \sin A}{\cos A - \sin A} - \frac{\cos A - \sin A}{\cos A + \sin A} = 2 \tan 2A$

(d)  $\sin(2n + 1)A \sin A = \sin^2(n + 1)A - \sin^2 nA$

(e)  $\tan 3\alpha \tan 2\alpha \tan \alpha = \tan 3\alpha - \tan 2\alpha - \tan \alpha$

6. Prove that:

(a)  $\sin 4\theta = 4 \sin \theta \cos^3 \theta - 4 \cos \theta \sin^3 \theta$

(b)  $\cos 4\theta = 1 - 8 \cos^2 \theta + 8 \cos^4 \theta$

7. Prove that

$$\left( 1 + \tan \frac{a}{2} - \sec \frac{a}{2} \right) \left( 1 + \tan \frac{a}{2} + \sec \frac{a}{2} \right) = \sin a \sec^2 \frac{a}{2}$$

8. Within what respective limits must  $A/2$  lie when

(a)  $2 \sin \frac{A}{2} = \sqrt{1 + \sin A} - \sqrt{1 - \sin A}$  ?

(b)  $2 \cos \frac{A}{2} = \sqrt{1 + \sin A} - \sqrt{1 - \sin A}$  ?

**Answer Keys**

2.  $\sqrt{2}$

3.  $\frac{1}{2} (x/y + y/x)$

8. (a)  $\left( 2n\pi - \frac{\pi}{4}, 2n\pi + \frac{\pi}{4} \right)$

(b)  $\left( 2n\pi + \frac{\pi}{4}, 2n\pi + \frac{3\pi}{4} \right)$

**Sum and Difference of Tangent and Cotangents**

Following mentioned conversions are sometimes very useful while simplifying the sums:

1.  $\tan A + \tan B = \frac{\sin(A+B)}{\cos A \cdot \cos B}$

$= \tan(A+B) \times (1 - \tan A \tan B)$ ; where  $A, B \neq n\pi + \pi/2$

2.  $\tan A - \tan B = \frac{\sin(A-B)}{\cos A \cdot \cos B}$

$= \tan(A-B) \times (1 + \tan A \tan B)$ ; where  $A, B \neq n\pi + \pi/2$

3.  $\cot A + \cot B = \frac{\sin(A+B)}{\sin A \cdot \sin B} = \frac{\cot A \cot B + 1}{\cot(A+B)}$

where  $A, B \neq n\pi, n \in \mathbb{Z}$

4.  $\cot A - \cot B = \frac{\sin(B-A)}{\sin A \cdot \sin B} = \frac{\cot A \cot B + 1}{\cot(B-A)}$

where  $A, B \neq n\pi, n \in \mathbb{Z}$

5.  $\tan A + \cot A = 2 \operatorname{cosec} 2A$

6.  $\tan A - \cot A = -2 \cot 2A$

**Conversion Formulae (Product into Sum)**

Using the formulae for  $\sin(A+B)$ ,  $\sin(A-B)$ ,  $\cos(A+B)$  and  $\cos(A-B)$  one can easily deduce the following important conversion formulae:

1.  $2 \sin A \cos B = \sin(A+B) + \sin(A-B)$

2.  $2 \cos A \sin B = \sin(A+B) - \sin(A-B)$

3.  $2 \cos A \cos B = \cos(A+B) + \cos(A-B)$

4.  $2 \sin A \sin B = \cos(A-B) - \cos(A+B)$

**ILLUSTRATION 27:** Simplify  $\frac{\sin 4\alpha \cos \alpha/2 - \sin 3\alpha \cos 3\alpha/2}{\cos \alpha \cos \alpha/2 - \sin 3\alpha/2 \sin 2\alpha}$ .

**SOLUTION:** By the above formulae, the expression

$$\begin{aligned} & \frac{1}{2} \left[ \sin \frac{9\alpha}{2} + \sin \frac{7\alpha}{2} \right] - \frac{1}{2} \left[ \sin \frac{9\alpha}{2} + \sin \frac{3\alpha}{2} \right] \\ &= \frac{1}{2} \left[ \cos \frac{3\alpha}{2} + \cos \frac{\alpha}{2} \right] - \frac{1}{2} \left[ \cos \frac{\alpha}{2} - \cos \frac{7\alpha}{2} \right] \\ &= \frac{\sin \frac{7\alpha}{2} - \sin \frac{3\alpha}{2}}{\cos \frac{3\alpha}{2} + \cos \frac{7\alpha}{2}} = \frac{2 \cos \frac{5\alpha}{2} \sin \alpha}{2 \cos \frac{5\alpha}{2} \cos \alpha} = \tan \alpha \end{aligned}$$

**ILLUSTRATION 28:** Prove that  $\sin(60^\circ - A) \sin A \sin(60^\circ + A) = \frac{1}{4} \sin 3A$ .

**SOLUTION:** Given that  $\sin(60^\circ - A) \sin A \sin(60^\circ + A) = \frac{1}{2} \sin A [2 \sin(60^\circ - A) \sin(60^\circ + A)]$

$$= \frac{1}{2} \sin A [\cos 2A - \cos 120^\circ] = \frac{1}{4} [2 \sin A \cos 2A - 2 \cos 120^\circ \sin A]$$

using  $2 \cos A \sin B = \sin(A + B) - \sin(A - B)$  and  $\cos 120^\circ = -1/2$

we get  $= \frac{1}{4} [\sin(2A + A) - \sin(2A - A) - 2(-1/2) \sin A] = \frac{1}{4} \sin 3A$

**ILLUSTRATION 29:** Show that  $\sin 12^\circ \cdot \sin 48^\circ \cdot \sin 54^\circ = 1/8$

**SOLUTION:** LHS  $= \frac{1}{2} [\cos 36^\circ - \cos 60^\circ] \sin 54^\circ = \frac{1}{2} \left[ \cos 36^\circ \sin 54^\circ - \frac{1}{2} \sin 54^\circ \right]$

$$= \frac{1}{4} [2 \cos 36^\circ \sin 54^\circ - \cos 54^\circ] = \frac{1}{4} [\sin 90^\circ + \sin 18^\circ - \sin 54^\circ]$$

$$= \frac{1}{4} [1 - (\sin 54^\circ - \sin 18^\circ)] = \frac{1}{4} [1 - 2 \sin 18^\circ \cos 36^\circ]$$

$$= \frac{1}{4} \left[ 1 - \frac{2 \sin 18^\circ}{\cos 18^\circ} \cos 18^\circ \cos 36^\circ \right] = \frac{1}{4} \left[ 1 - \frac{\sin 36^\circ \cos 36^\circ}{\cos 18^\circ} \right]$$

$$= \frac{1}{4} \left[ 1 - \frac{2 \sin 36^\circ \cos 36^\circ}{2 \cos 18^\circ} \right] = \frac{1}{4} \left[ 1 - \frac{\sin 72^\circ}{2 \sin 72^\circ} \right] = \frac{1}{4} \left[ 1 - \frac{1}{2} \right] = \frac{1}{8}$$

## TEXTUAL EXERCISE-12 (SUBJECTIVE)

1. Prove that

$$(\sin \alpha + \sin \alpha/3) \sin \alpha/3 + (\cos \alpha - \cos \alpha/3) \cos \alpha/3 = 0$$

2. Prove that

$$\frac{\sin x \sin 2x + \sin 3x \sin 6x + \sin 4x \sin 13x}{\sin x \cos 2x + \sin 3x \cos 6x + \sin 4x \cos 13x} = \tan 9x$$

3. Prove that  $\cos \alpha \sin(\beta - \gamma) + \cos \beta \sin(\gamma - \alpha) + \cos \gamma \sin(\alpha - \beta) = 0$

4. Prove that  $\sin(45^\circ + \alpha) \sin(45^\circ - \alpha) = \frac{1}{2} \cos 2\alpha$



## CONVERSION FORMULAE (SUM INTO PRODUCT)

Many formulae are being derived here from the above found identities which relates sum and difference of sine (cosines) to product.

$$\sin(A+B) = \sin A \cos B + \cos A \sin B \quad \dots(i)$$

$$\text{and } \sin(A-B) = \sin A \cos B - \cos A \sin B \quad \dots(ii)$$

By adding and subtracting (i) and (ii), we get

$$\sin(A+B) + \sin(A-B) = 2 \sin A \cdot \cos B \quad \dots(iii)$$

$$\sin(A+B) - \sin(A-B) = 2 \cos A \cdot \sin B \quad \dots(iv)$$

$$\text{then, } A = \frac{C+D}{2} \text{ and } B = \frac{C-D}{2}.$$

Putting these values in equation (iii) and (iv), we get

$$\sin C + \sin D = 2 \sin \left( \frac{C+D}{2} \right) \cdot \cos \frac{C-D}{2} :$$

$$\sin C - \sin D = 2 \cos \left( \frac{C+D}{2} \right) \cdot \sin \left( \frac{C-D}{2} \right)$$

Similarly, we get the following formulae

$$\cos C + \cos D = 2 \cos \left( \frac{C+D}{2} \right) \cdot \cos \left( \frac{C-D}{2} \right)$$

$$\text{and } \cos C - \cos D = 2 \sin \left( \frac{C+D}{2} \right) \cdot \sin \left( \frac{D-C}{2} \right)$$

Notice the term  $(D-C)$  and think of its reason

**ILLUSTRATION 30:** Prove the following: (a)  $\sin 70^\circ + \sin 10^\circ = \sqrt{3} \sin 40^\circ$  (b)  $\cos 20^\circ - \sin 20^\circ = \sqrt{2} \sin 25^\circ$

$$\text{SOLUTION: (a) } \sin 70^\circ + \sin 10^\circ = 2 \sin \frac{70^\circ+10^\circ}{2} \cos \frac{70^\circ-10^\circ}{2} = 2 \sin 40^\circ \cos 30^\circ = \sqrt{3} \sin 40^\circ$$

$$\begin{aligned} \text{(b) } \cos 20^\circ - \sin 20^\circ &= \cos 20^\circ - \cos 70^\circ \\ &= 2 \sin \frac{20^\circ+70^\circ}{2} \sin \frac{70^\circ-20^\circ}{2} = 2 \sin 45^\circ \cos 25^\circ = \sqrt{2} \sin 25^\circ \end{aligned}$$

**ILLUSTRATION 31:** Simplify the expression  $\frac{(\cos \alpha - \cos 3\alpha)(\sin 8\alpha + \sin 2\alpha)}{(\sin 5\alpha - \sin \alpha)(\cos 4\alpha - \cos 6\alpha)}$ .

**SOLUTION:** Applying the CD formulae, we get

$$\begin{aligned} &= \frac{2 \sin \frac{\alpha+3\alpha}{2} \sin \frac{3\alpha-\alpha}{2} \times 2 \sin \frac{8\alpha+2\alpha}{2} \cos \frac{8\alpha-2\alpha}{2}}{2 \cos \frac{5\alpha+\alpha}{2} \sin \frac{5\alpha-\alpha}{2} \times 2 \sin \frac{4\alpha+6\alpha}{2} \sin \frac{6\alpha-4\alpha}{2}} \\ &= \frac{4 \sin 2\alpha \sin \alpha \cdot \sin 5\alpha \cdot \cos 3\alpha}{4 \cdot \cos 3\alpha \sin 2\alpha \sin 5\alpha \sin \alpha} = 1. \end{aligned}$$

**ILLUSTRATION 32:** Prove that  $\sin \alpha + \sin \left( \alpha + \frac{2\pi}{3} \right) + \sin \left( \alpha + \frac{4\pi}{3} \right) = 0$

$$\begin{aligned} \text{SOLUTION: L.H.S} &= \sin \alpha + \sin \left( \pi - \left( \frac{\pi}{3} - \alpha \right) \right) + \sin \left( \pi + \frac{\pi}{3} + \alpha \right) \\ &= \sin \alpha + \sin \left( \frac{\pi}{3} - \alpha \right) - \sin \left( \frac{\pi}{3} + \alpha \right) \\ &= \sin \alpha - \left[ \sin \left( \frac{\pi}{3} + \alpha \right) - \sin \left( \frac{\pi}{3} - \alpha \right) \right] = \sin \alpha - 2 \sin \alpha \cos \frac{\pi}{3} = \sin \alpha - \sin \alpha = 0 = \text{RHS.} \end{aligned}$$

**TEXTUAL EXERCISE-13 (SUBJECTIVE)**

1. Prove that  $2 \cos\left(\frac{A+3B}{2}\right) \cos\left(\frac{3A-B}{2}\right)$   
 $= \cos(2A+B) + \cos(A-2B)$
2. Prove that  
 $\sin(A+B) \cdot \sin(A-B) = \frac{1}{2}[2 \sin(A+B) \cdot \sin(A-B)]$   
 $= \frac{1}{2}(\cos 2B - \cos 2A)$
3. Prove the following:  
 (a)  $\frac{\sin(x+y) - 2 \sin x + \sin(x-y)}{\cos(x+y) - 2 \cos x + \cos(x-y)} = \tan x$   
 (b)  $\frac{\sin(a-c) + 2 \sin a + \sin(a+c)}{\sin(b-c) + 2 \sin b + \sin(b+c)} = \frac{\sin a}{\sin b}$

- (c)  $\frac{\sin A + \sin B}{\sin A - \sin B} = \tan \frac{A+B}{2} \cot \frac{A-B}{2}$   
 (d)  $\frac{\cos A + \cos B}{\cos A - \cos B} = -\cot \frac{A+B}{2} \cot \frac{A-B}{2}$   
 (e)  $\cos(-B+C+A) + \cos(-A+B+C) + \cos(A+B-C) + \cos(A+B+C) = 4 \cos A \cos B \cos C$

4. Simplify the following identities:

- (a)  $\cos\left\{\theta + \left(n - \frac{3}{2}\right)\phi\right\} - \cos\left\{\theta + \left(n + \frac{3}{2}\right)\phi\right\}$   
 (b)  $\sin\left\{\theta + \left(n - \frac{1}{2}\right)\phi\right\} + \sin\left\{\theta + \left(n + \frac{1}{2}\right)\phi\right\}$

**Answer Keys**

4. (a)  $2 \sin(\theta + n\phi) \sin 3\phi/2$  (b)  $2 \sin(\theta + n\phi) \cos \phi/2$

**TRIGONOMETRIC RATIOS OF THE SUM OF THREE OR MORE ANGLES**

The formulae for the compound angles can be extended to multiple angles as given below:

1.  $\sin(A+B+C) = \sin A \cos B \cos C + \cos A \sin B \cos C + \cos A \cos B \sin C - \sin A \sin B \sin C$  or

$$\sin(A+B+C) = \cos A \cos B \cos C (\tan A + \tan B + \tan C - \tan A \tan B \tan C)$$

**Proof:**  $\sin(A+B+C) = \sin(A+B) \cos C + \cos(A+B) \sin C$

$$= (\sin A \cos B + \cos A \sin B) \cos C + (\cos A \cos B - \sin A \sin B) \sin C$$

$$= \sin A \cos B \cos C + \cos A \sin B \cos C + \cos A \cos B \sin C - \sin A \sin B \sin C$$

$$= \cos A \cos B \cos C \left[ \frac{\sin A}{\cos A} + \frac{\sin B}{\cos B} + \frac{\sin C}{\cos C} - \frac{\sin A \sin B \sin C}{\cos A \cos B \cos C} \right]$$

$$= \cos A \cos B \cos C (\tan A + \tan B + \tan C - \tan A \tan B \tan C)$$

**Generalized form:**  $\sin(A_1 + A_2 + \dots + A_n) = \cos A_1 \cos A_2 \dots \cos A_n (S_1 - S_3 + S_5 - S_7 + \dots)$

2.  $\cos(A+B+C) = \cos A \cos B \cos C - \sin A \sin B \cos C - \sin A \cos B \sin C - \cos A \sin B \sin C$

$$\text{or } \cos(A+B+C) = \cos A \cos B \cos C (1 - \tan A \tan B - \tan B \tan C - \tan C \tan A)$$

**Proof:**  $= (\cos A \cos B - \sin A \sin B) \cos C - (\sin A \cos B + \cos A \sin B) \sin C$

$$= \cos A \cos B \cos C - \sin A \sin B \cos C - \sin A \cos B \sin C - \cos A \sin B \sin C$$

$$= \cos A \cos B \cos C$$

$$\left[ \frac{\sin A \sin B}{\cos A \cos B} - \frac{\sin A \sin C}{\cos A \cos C} - \frac{\sin B \sin C}{\cos B \cos C} \right]$$

$$= \cos A \cos B \cos C (1 - \tan A \tan B - \tan B \tan C - \tan C \tan A)$$

**Generalized form:**  $\cos(A_1 + A_2 + \dots + A_n) = \cos A_1 \cos A_2 \dots \cos A_n (1 - S_2 + S_4 - S_6 + \dots)$

**Method II:** The above two results can also be derived with use of polar form of a complex number.

$$\cos(A+B+C) + i \sin(A+B+C) = (\cos A + i \sin A) (\cos B + i \sin B) (\cos C + i \sin C)$$

$$= \cos A \cos B \cos C + i \sum \cos A \cdot \cos B \cdot \sin C + i^2 \sum \cos A \cdot \sin B \cdot \sin C + i^3 \sin A \cdot \sin B \cdot \sin C$$

1.42 > Trigonometry

$$= (\cos A \cos B \cos C) (1 + i \sum \tan A + i^2 \sum \tan A \tan B + i^3 (\tan A \tan B \tan C)).$$

Now, equate and imaginary parts.

**Generalizing using this method**

$$\cos(A_1 + A_2 + A_3 + A_4 + \dots + A_n) + i \sin(A_1 + A_2 + A_3 + A_4 + \dots + A_n) = (\cos A_1 \cos A_2 \cos A_3 \dots \cos A_n) \times (1 + i \sum \tan A_1 + i^2 \sum \tan A_1 \tan A_2 + i^3 \sum \tan A_1 \tan A_2 \tan A_3 + \dots + i^n \sum \tan A_1 \tan A_2 \tan A_3 \dots \tan A_n).$$

Comparing the real and imaginary parts, we get the desired formulae for  $\cos(A_1 + A_2 + A_3 + A_4 + \dots + A_n)$  and  $\sin(A_1 + A_2 + A_3 + A_4 + \dots + A_n)$ .

3.  $\tan(A + B + C)$

$$= \frac{\tan A + \tan B + \tan C - \tan A \tan B \tan C}{1 - \tan A \tan B - \tan B \tan C - \tan A \tan C}$$

**Generalized form:**  $\tan(A_1 + A_2 + \dots + A_n)$

$$= \frac{S_1 - S_3 + S_5 - S_7 + \dots}{1 - S_2 + S_4 - S_6 + \dots}$$

4.  $\cot(A + B + C)$

$$= \frac{\cot A \cot B \cot C - (\cot A + \cot B + \cot C)}{\sum \cot A \cot B - 1}$$

**NOTES**

Representation of the variables  $S_1, S_2, S_3, \dots$  used in the generalized form:

$S_1 = \tan A_1 + \tan A_2 + \dots + \tan A_n$  = the sum of the tangents of the separate angles.

$S_2 = \tan A_1 \tan A_2 + \tan A_1 \tan A_3 + \dots$  = the sum of the product of tangents of angles taken two at a time.

$S_3 = \tan A_1 \tan A_2 \tan A_3 + \tan A_1 \tan A_2 \tan A_4 + \dots$  = sum of the product of tangents of angles taken three at a time, and so on.

If  $A_1 = A_2 = \dots = A_n = A$ , then  $S_1 = {}^n C_1 \tan A; S_2 = {}^n C_2 \tan^2 A; S_3 = {}^n C_3 \tan^3 A, \dots$

**ILLUSTRATION 33:** If  $\tan \theta_1, \tan \theta_2, \tan \theta_3$  and  $\tan \theta_4$  are the roots of the equation  $x^4 - (\sin 2\beta)x^3 + (\cos 2\beta)x^2 - (\cos \beta)x - \sin \beta = 0$  then  $\tan(\theta_1 + \theta_2 + \theta_3 + \theta_4)$  is equal to

- (a)  $\cos \beta$                       (b)  $\sin \beta$                       (c)  $\tan \beta$                       (d)  $\cot \beta$

**SOLUTION:** (d)  $\tan(\theta_1 + \theta_2 + \theta_3 + \theta_4) = \frac{S_1 - S_3}{1 - S_2 + S_4}$   

$$= \frac{\sin 2\beta - \cos \beta}{1 - \cos 2\beta - \sin \beta} = \frac{\cos \beta (2 \sin \beta - 1)}{\sin \beta (2 \sin \beta - 1)} = \cot \beta.$$

**TEXTUAL EXERCISE-4 (OBJECTIVE)**

1. Which of the following is rational?

- (a)  $\sin 15^\circ$                       (b)  $\cos 15^\circ$   
 (c)  $\sin 15^\circ \cos 15^\circ$               (d)  $\sin 15^\circ \cos 75^\circ$

2. The value of  $\frac{1 + \sin \theta - \cos \theta}{1 + \sin \theta + \cos \theta}$  is

- (a)  $\cot \theta/2$                       (b)  $\tan \theta/2$   
 (c)  $\tan \theta$                       (d) None of these

3. If  $\cos \alpha = 3/5, \cos \beta = 4/5, \alpha, \beta > 0$  and are acute angles, then  $\cos \frac{\alpha - \beta}{2}$  is

- (a)  $\frac{7}{2}\sqrt{5}$                       (b)  $\frac{35}{2}$   
 (c)  $\frac{3\sqrt{5}}{2}$                       (d) None of these

4. If  $\tan \theta = 1/\sqrt{3}$ , then the value of  $\sqrt{3} \cos 2\theta + \sin 2\theta$  is

- (a)  $\sqrt{3}$                       (b) 1  
 (c)  $1 + \sqrt{3}$                       (d) None of these

5. The value of  $\cos(\pi/13) + \cos(2\pi/13) + \dots + \cos(12\pi/13)$  is equal to

- (a) 0 (b) 1  
(c) 9 (d) None of these
6. The expression  $\frac{1}{\tan 3A - \tan A} - \frac{1}{\cot 3A - \cot A}$  equals  
(a)  $\cot 2A$  (b)  $\tan 2A$   
(c)  $\cot 3A$  (d)  $\tan 3A$
7. In a triangle  $ABC$ ,  $\sum \sin A \sin(B - C)$  equal  
(a) 1 (b) 0  
(c)  $-32$  (d) None of these
8. If  $\tan A = 2 \tan B + \cot B$ , then  $2 \tan(A - B) =$   
(a)  $\tan B$  (b)  $2 \tan B$   
(c)  $\cot B$  (d)  $2 \cot B$
9. If  $\sin A = \sin B$  and  $\cos A = \cos B$ , then  
(a)  $\sin \frac{A-B}{2} = 0$  (b)  $\sin \frac{A+B}{2} = 0$   
(c)  $\cos \frac{A-B}{2} = 0$  (d)  $\cos(A + B) = 0$
10. If  $\cos^2 48^\circ - \sin^2 12^\circ =$   
(a)  $\frac{\sqrt{5}-1}{4}$  (b)  $\frac{\sqrt{5}+1}{8}$   
(c)  $\frac{\sqrt{3}+1}{4}$  (d)  $\frac{\sqrt{3}+1}{2\sqrt{2}}$
11.  $\sin 75^\circ =$   
(a)  $\frac{2-\sqrt{3}}{2}$  (b)  $\frac{\sqrt{3}+1}{2\sqrt{2}}$   
(c)  $\frac{\sqrt{3}-1}{-2\sqrt{2}}$  (d)  $\frac{\sqrt{3}-1}{2\sqrt{2}}$
12. The value of  $\cos 15^\circ - \sin 15^\circ$  is equal to  
(a)  $\frac{1}{\sqrt{2}}$  (b)  $\frac{1}{2}$   
(c)  $-\frac{1}{\sqrt{2}}$  (d) 0
13. If  $\tan \alpha = (1 + 2^{-x})^{-1}$ ,  $\tan \beta = (1 + 2^{x+1})^{-1}$ , then  $\alpha + \beta$  equals  
(a)  $\pi/6$  (b)  $\pi/4$   
(c)  $\pi/3$  (d)  $\pi/2$
14. If  $\cos A = m \cos B$ , then  
(a)  $\cot \frac{A+B}{2} = \frac{m+1}{m-1} \tan \frac{B-A}{2}$   
(b)  $\tan \frac{A+B}{2} = \frac{m+1}{m-1} \cot \frac{B-A}{2}$   
(c)  $\cot \frac{A+B}{2} = \frac{m+1}{m-1} \tan \frac{A-B}{2}$   
(d) None of these
15.  $\cos^2 \left( \frac{\pi}{6} + \theta \right) - \sin^2 \left( \frac{\pi}{6} - \theta \right) =$   
(a)  $\frac{1}{2} \cos 2\theta$  (b) 0  
(c)  $-\frac{1}{2} \cos 2\theta$  (d)  $-$
16. If  $\frac{\sin(x+y)}{\sin(x-y)} = \frac{a+b}{a-b}$ , then  $\frac{\tan x}{\tan y}$  is equal to  
(a)  $-$   
(b)  $\frac{a}{b}$   
(c)  $ab$   
(d) None of these
17. If  $\tan \frac{A}{2} = \frac{3}{2}$ , then  $\frac{1+\cos A}{1-\cos A} =$   
(a)  $-5$  (b) 5  
(c)  $9/4$  (d)  $4/9$
18.  $\frac{\sin 2A}{1+\cos 2A} \cdot \frac{\cos A}{1+\cos A} =$   
(a)  $\tan \frac{A}{2}$  (b)  $\cot \frac{A}{2}$   
(c)  $\sec \frac{A}{2}$  (d)  $\operatorname{cosec} \frac{A}{2}$

## Answer Keys

1. (c) 2. (b) 3. (d) 4. (a) 5. (a) 6. (a) 7. (b) 8. (c) 9. (a) 10. (b)  
11. (b) 12. (a) 13. (b) 14. (a) 15. (a) 16. (b) 17. (d) 18. (a)

### CONDITIONAL IDENTITIES

Using the fact that the sum of the angles of a triangle  $ABC$  is 180 degrees, we can derive several identities, which will be useful later. Generally, in these identities we express sums into products. If the sums are symmetric functions of  $A, B, C$  so are the products.

First we mention a few simple relations governed by the condition  $A + B + C = 180^\circ$

- (a)  $\sin(A + B) = \sin(180^\circ - C) = \sin C$   
 (b)  $\cos(B + C) = \cos(180^\circ - A) = -\cos A$

- (c)  $\tan(C + A) = \tan(180^\circ - B) = -\tan B$   
 (d)  $\sin((A + B)/2) = \sin(90^\circ - C/2) = \cos(C/2)$   
 (e)  $\cos((B + C)/2) = \cos(90^\circ - A/2) = \sin(A/2)$   
 (f)  $\tan((C + A)/2) = \tan(90^\circ - B/2) = \cot(B/2)$   
 (g)  $\sin\left(\frac{A+B}{4}\right) = \sin\left(\frac{\pi-C}{4}\right) = \sin\left(\frac{\pi}{2} - \frac{\pi+C}{4}\right)$   
 $= \cos\left(\frac{\pi+C}{4}\right)$

**ILLUSTRATION 34:** Prove that if  $A + B + C = \pi$ , then  $\tan A + \tan B + \tan C = \tan A \tan B \tan C$

**SOLUTION:** We know that  $A + B + C = \pi$

$$\begin{aligned} \Rightarrow A + B &= \pi - C & \Rightarrow \tan(A + B) &= \tan(\pi - C) \\ \Rightarrow \frac{\tan A + \tan B}{1 - \tan A \tan B} &= -\tan C & \Rightarrow \tan A + \tan B + \tan C &= \tan A \tan B \tan C \end{aligned}$$

**ILLUSTRATION 35:** If  $A + B + C = \pi$ , then prove that  $\sin 2A + \sin 2B + \sin 2C = 4 \sin A \sin B \sin C$

**SOLUTION:** L.H.S =  $\sin 2A + \sin 2B + \sin 2C = 2 \sin(A + B) \cos(A - B) + 2 \sin C \cos C$   
 $= 2 \sin C [\cos(A - B) + \cos(\pi - (A + B))] \quad [\because A + B = \pi - C]$   
 $= 2 \sin C [\cos(A - B) - \cos(A + B)] = 2 \cdot 2 \sin C \cdot \sin A \sin B = 4 \sin A \sin B \sin C = \text{R.H.S}$

**ILLUSTRATION 36:** If  $A + B + C = \pi$ , then prove that

$$\cos A \cos B \cos C - \cos A \sin B \sin C - \sin A \cos B \sin C - \sin A \sin B \cos C = -1$$

**SOLUTION:** We know that

$$\cos(A + B + C) = \cos A \cos B \cos C - \cos A \sin B \sin C - \sin A \cos B \sin C - \sin A \sin B \cos C$$

So, put  $A + B + C = \pi$ , then we get, required result

**ILLUSTRATION 37:** To prove  $\sin 2A + \sin 2B - \sin 2C = 4 \cos A \cos B \sin C$

**SOLUTION:** L.H.S. =  $2 \sin(A + B) \cos(A - B) - 2 \sin C \cos C = 2 \sin(180^\circ - C) \cos(A - B) - 2 \sin C \cos C$   
 $= 2 \sin C \{\cos(A - B) - \cos C\}$   
 $= 2 \sin C \{\cos(A - B) + \cos(A + B)\} \quad [\because \cos(180^\circ - (A + B)) = \cos(A + B)]$   
 $= 2 \sin C (2 \cos A \cos B) = 4 \cos A \cos B \sin C$

**ILLUSTRATION 38:** To prove  $\sin A + \sin B + \sin C = 4 \cos \frac{A}{2} \cos \frac{B}{2} \cos \frac{C}{2}$

**SOLUTION:** L.H.S. =  $2 \sin \frac{A+B}{2} \cos \frac{A-B}{2} + 2 \sin \frac{C}{2} \cos \frac{C}{2}$   
 $= 2 \sin(90^\circ - C/2) \cos \frac{A-B}{2} + 2 \sin \frac{C}{2} \cos \frac{C}{2} \quad \left( \because \frac{A}{2} + \frac{B}{2} = \frac{\pi}{2} - \frac{C}{2} \right)$   
 $= 2 \cos C/2 \left\{ \cos \frac{A-B}{2} + \sin C/2 \right\} = 2 \cos C/2 \left\{ \cos \frac{A-B}{2} + \cos \frac{A+B}{2} \right\}$   
 $= 2 \cos C/2 \{2 \cos A/2 \cos B/2\} = 4 \cos A/2 \cos B/2 \cos C/2$

**ILLUSTRATION 39:** Prove that  $\cos^2 A + \cos^2 B + \cos^2 C = 1 - 2 \cos A \cos B \cos C$

**SOLUTION:** L.H.S =  $\cos^2 A + \cos^2 B + \cos^2 C = \frac{1 + \cos 2A}{2} + \frac{1 + \cos 2B}{2} + \cos^2 C$

$$= \frac{1}{2}[2 + \cos 2A + \cos 2B] + \cos^2 C = \frac{1}{2}[2 + 2 \cos(A+B) \cos(A-B)] + \cos^2 C$$

$$= 1 + \cos(180^\circ - C) \cos(A-B) + \cos^2 C = 1 - \cos C \cos(A-B) + \cos^2 C$$

$$= 1 - \cos C [\cos(A-B) - \cos C] = 1 - \cos C [\cos(A-B) + \cos(A+B)]$$

$$= 1 - 2 \cos A \cos B \cos C$$

**ILLUSTRATION 40:** Prove that  $\cot(A/2) + \cot(B/2) + \cot(C/2) = \cot(A/2) \cot(B/2) \cot(C/2)$

**SOLUTION:** We know that  $(A/2) + (B/2) = 90^\circ - C/2$

Hence  $\cot[(A/2 + B/2)] = \cot[90^\circ - C/2]$

$$\Rightarrow \frac{\cot(A/2) \cot(B/2) - 1}{\cot(A/2) + \cot(B/2)} = \tan(C/2) = \frac{1}{\cot(C/2)}$$

$$\Rightarrow \cot(A/2) \cot(B/2) \cot(C/2) - \cot(C/2) = \cot(A/2) + \cot(B/2)$$

$$\Rightarrow \cot(A/2) \cot(B/2) \cot(C/2) - \cot(C/2) = \cot(A/2) + \cot(B/2)$$

$$\Rightarrow \cot(A/2) + \cot(B/2) + \cot(C/2) = \cot(A/2) \cot(B/2) \cot(C/2)$$

## NOTES

If  $A + B + C = \pi$ , then

- $\sin 2mA + \sin 2mB + \sin 2mC = (-1)^{m+1} 4 \sin mA \sin mB \sin mC$
- $\cos mA + \cos mB + \cos mC = 1 \pm 4 \sin \frac{mA}{2} \sin \frac{mB}{2} \sin \frac{mC}{2}$  (+ for  $m = 4n + 1$ , - for  $m = 4n + 3$ )  
 $1 \pm 4 \cos \frac{mA}{2} \cos \frac{mB}{2} \cos \frac{mC}{2}$  (+ for  $m = 4n + 4$ , - for  $m = 4n + 2$ )
- $\cos A + \cos B + \cos C + \cos(A+B+C) = 4 \cos \left( \frac{A+B}{2} \right) \cos \left( \frac{B+C}{2} \right) \cos \left( \frac{C+A}{2} \right)$
- $\sin A + \sin B + \sin C - \sin(A+B+C) = 4 \sin \left( \frac{A+B}{2} \right) \sin \left( \frac{B+C}{2} \right) \sin \left( \frac{C+A}{2} \right)$

## TEXTUAL EXERCISE-14 (SUBJECTIVE)

- |  |   |
|--|---|
| <ol style="list-style-type: none"> <li>If <math>A + B + C = \pi</math>, prove that <math>\sum \cos 2A = -1 - 4 \prod \cos A</math></li> <li>If <math>A + B + C = \pi</math>, prove that             <ol style="list-style-type: none"> <li><math>\cot A \cot B + \cot B \cot C + \cot C \cot A = 1</math></li> <li><math>\tan \frac{A}{2} \tan \frac{B}{2} + \tan \frac{B}{2} \tan \frac{C}{2} + \tan \frac{C}{2} \tan \frac{A}{2} = 1</math></li> </ol> </li> </ol> | <ol style="list-style-type: none"> <li>If <math>A + B + C = \pi</math>, prove that             <math display="block">\cos A + \cos B - \cos C = -1 + 4 \cos \frac{A}{2} \cos \frac{B}{2} \sin \frac{C}{2}</math> </li> <li>If <math>A + B + C = \pi</math>, prove that             <ol style="list-style-type: none"> <li><math>\sin^2 A + \sin^2 B + \sin^2 C = 2 + 2 \cos A \cos B \cos C</math></li> <li><math>\cos^2 A + \cos^2 B - \cos^2 C = 1 - 2 \sin A \sin B \cos C</math></li> </ol> </li> </ol> |
|--|---|

5. If  $A + B + C = \pi$ , prove that

(a) 
$$\cos \frac{A}{2} + \cos \frac{B}{2} + \cos \frac{C}{2} = 4 \cos \left( \frac{\pi - A}{4} \right) \cos \left( \frac{\pi - B}{4} \right) \cos \left( \frac{\pi - C}{4} \right)$$

(b) 
$$\sin \frac{A}{2} + \sin \frac{B}{2} + \sin \frac{C}{2} = 1 + 4 \sin \left( \frac{\pi - A}{4} \right) \sin \left( \frac{\pi - B}{4} \right) \sin \left( \frac{\pi - C}{4} \right)$$

6. If  $A + B + C = \pi$ . Prove that

$$\frac{\cot A + \cot B}{\tan A + \tan B} + \frac{\cot B + \cot C}{\tan B + \tan C} + \frac{\cot C + \cot A}{\tan C + \tan A} = 1$$

7. Prove that  $\tan(x - y) + \tan(y - z) + \tan(z - x) = \tan(x - y) \tan(y - z) \tan(z - x)$ .

8. If  $A + B + C = \pi$ . Prove that

(a) 
$$\frac{\cos A}{\sin B \sin C} + \frac{\cos B}{\sin C \sin A} + \frac{\cos C}{\sin A \sin B} = 2$$

(b) 
$$\sin(B + C - A) + \sin(C + A - B) - \sin(A + B - C) = 4 \cos A \cos B \sin C$$

### TEXTUAL EXERCISE-5 (OBJECTIVE)

1. If  $A + B + C = (2n + 1)\pi$ , then

$\tan A + \tan B + \tan C$  is equal to

- (a)  $\tan A \tan B \tan C$       (b)  $\sum \tan A \tan B$   
 (c)  $\sum \tan^3 A$               (d) None of these

2. If  $\alpha + \beta - \gamma = \pi$ , then  $\sin^2 \alpha + \sin^2 \beta - \sin^2 \gamma =$

- (a)  $2 \sin \alpha \sin \beta \cos \gamma$       (b)  $2 \cos \alpha \cos \beta \cos \gamma$   
 (c)  $2 \sin \alpha \sin \beta \cos \gamma$       (d) None of these

3. If  $A, B, C, D$  are the angles of a cyclic quadrilateral, then  $\cos A + \cos B + \cos C + \cos D =$

- (a)  $2(\cos A + \cos C)$       (b)  $2(\cos A + \cos B)$   
 (c)  $2(\cos A + \cos D)$       (d) 0

4. In a triangle  $ABC$  the value of  $\sin A + \sin B + \sin C$  is

- (a)  $4 \sin \frac{A}{2} \sin \frac{B}{2} \sin \frac{C}{2}$   
 (b)  $4 \cos \frac{A}{2} \cos \frac{B}{2} \cos \frac{C}{2}$

(c)  $4 \cos \frac{A}{2} \sin \frac{B}{2} \sin \frac{C}{2}$

(d)  $4 \cos \frac{A}{2} \sin \frac{B}{2} \cos \frac{C}{2}$

5. In a triangle  $\tan A + \tan B + \tan C = 6$  and  $\tan A \tan B = 2$ , then the values of  $\tan A, \tan B$  and  $\tan C$  are

- (a)  $1/2, 4, 3/2$               (b)  $2, 1, 3$   
 (c)  $1, 2, 0$                   (d) None of these

6. If  $A + B + C = 180^\circ$ , then the value of  $(\cot B + \cot C)(\cot C + \cot A)(\cot A + \cot B)$  will be

- (a)  $\sec A \sec B \sec C$       (b)  $\operatorname{cosec} A \operatorname{cosec} B \operatorname{cosec} C$   
 (c)  $\tan A \tan B \tan C$       (d) 1

7. If  $A + B + C = 180^\circ (A, B > 0)$  and the angle  $C$  is obtuse, then

- (a)  $\tan A \tan B > 1$       (b)  $\tan A \tan B < 1$   
 (c)  $\tan A \tan B = 1$       (d) None of these

### Answer Keys

1. (a)      2. (c)      3. (d)      4. (b)      5. (b)      6. (b)      7. (b)

### ■ APPLICATION OF TRIGONOMETRY FOR ELIMINATING VARIABLES

Suppose we have two independent simultaneous equations in one unknown quantity. Then generally it is possible to eliminate one unknown from the two equations to generate a relation connecting the other parameters in the given

two equations. Such relation obtained is called **eliminant equation**. e.g., suppose we wish to eliminate  $x$  from the equations  $px + q = 0 \dots(i)$  and  $ax^3 + bx + c = 0 \dots(ii)$

From equation (i) we have  $x = -q/p$ . Substituting this in the equation (ii), we get  $a(-q/p)^3 + b(-q/p) + c = 0$ .

i.e.,  $aq^3 + bp^2q - cp^3 = 0$  which is the result of elimination so called the **eliminant**.

**ILLUSTRATION 41:** Eliminate the parameter  $\alpha$  from the two equations  $x = a \sin^3 \alpha$  and  $y = a \cos^3 \alpha$  and obtain the eliminant equation in  $x$  and  $y$ .

**SOLUTION:** Given equations are  $x = a \sin^3 \alpha$  .....(i)

and  $y = a \cos^3 \alpha$  .....(ii)

Solving for  $\sin \alpha$  and  $\cos \alpha$  from the above  $\sin \alpha = \left(\frac{x}{a}\right)^{1/3}$  and  $\cos \alpha = \left(\frac{y}{a}\right)^{1/3}$

Since we know that  $\sin^2 \alpha + \cos^2 \alpha = 1$ , so  $\left(\frac{x}{a}\right)^{2/3} + \left(\frac{y}{a}\right)^{2/3} = 1$

$\Rightarrow x^{2/3} + y^{2/3} = a^{2/3}$  which is the required eliminant.

## NOTE

Similarly, if we have 3 independent equations in 2 unknowns or in general  $(n + 1)$  independent equations in 'n' unknowns, theoretically we can eliminate the unknowns from the given system and obtain the eliminant. There is no general method which is applicable to all cases (or even majority of the cases) and each problem has to be treated in its own special way. A certain amount of ingenuity is required in some cases to arrive at the eliminant. Thus to eliminate these parameters we have to use basic trigonometric formulae. It could be more clear by some examples given below:

**ILLUSTRATION 42:** Eliminate  $\theta$  from the equations  $a \tan^m \theta = b$  and  $c \sec^n \theta = d$ .

**SOLUTION:** From the given equations we have  $\tan \theta = (b/a)^{1/m}$  and  $\sec \theta = (d/c)^{1/n}$

But  $1 + \tan^2 \theta = \sec^2 \theta$  for all values of  $\theta$

So  $\left(\frac{d}{c}\right)^{2/n} - \left(\frac{b}{a}\right)^{2/m} = 1$  which is the required eliminant.

**ILLUSTRATION 43:** Eliminate  $\theta$  from the equations

$a \cos x + b \sin x = e$  .....(i)

and  $d \cos x + c \sin x = f$  .....(ii)

**SOLUTION:** Solving for  $\cos x$  and  $\sin x$  by cross multiplication, or otherwise, we have

$$\frac{\cos x}{bf - ce} = \frac{\sin x}{ed - af} = \frac{1}{bd - ac} \quad \therefore 1 = \cos^2 x + \sin^2 x = \frac{(bf - ce)^2 + (ed - af)^2}{(bd - ac)^2}$$

so that  $(bf - ce)^2 + (ed - af)^2 = (bd - ac)^2$  which is the required eliminant equation.

**ILLUSTRATION 44:** Eliminate  $\theta$  from the following two equations:

$x \sin \theta - y \cos \theta = \sqrt{x^2 + y^2}$  .....(i)

and  $\frac{\sin^2 \theta}{a^2} + \frac{\cos^2 \theta}{b^2} = \frac{1}{x^2 + y^2}$  .....(ii)

**SOLUTION:** From (i) squaring both sides, we have  $x^2 \sin^2 \theta - 2xy \sin \theta \cos \theta + y^2 \cos^2 \theta = x^2 + y^2$

Therefore  $x^2 \cos^2 \theta + 2xy \sin \theta \cos \theta + y^2 \sin^2 \theta = 0$  giving  $(x \cos \theta + y \sin \theta)^2 = 0$

Hence  $\frac{\sin \theta}{x} = \frac{\cos \theta}{-y} = k$





**TEXTUAL EXERCISE-6 (OBJECTIVE)**

1. If  $x = a \cos^3\theta$ ,  $y = b \sin^3\theta$ , then

(a)  $\left(\frac{a}{x}\right)^{2/3} + \left(\frac{b}{y}\right)^{2/3} = 1$

(b)  $\left(\frac{b}{x}\right)^{2/3} + \left(\frac{a}{y}\right)^{2/3} = 1$

(c)  $\left(\frac{x}{a}\right)^{2/3} + \left(\frac{y}{b}\right)^{2/3} = 1$

(d)  $\left(\frac{x}{b}\right)^{2/3} + \left(\frac{y}{a}\right)^{2/3} = 1$

2.  $\theta$  eliminant between the equations

$$x = a \sec^3\theta, y = b \tan^3\theta \text{ is}$$

(a)  $\left(\frac{x}{a}\right)^{2/3} + \left(\frac{y}{b}\right)^{2/3} = 1$

(b)  $\left(\frac{x}{a}\right)^{2/3} - \left(\frac{y}{b}\right)^{2/3} = 1$

(c)  $\left(\frac{x}{a}\right)^{2/3} - \left(\frac{y}{b}\right)^{2/3} = -1$

(d) None of these

3. If  $\sin\theta + \cos\theta = m$  and  $\sec\theta + \operatorname{cosec}\theta = n$ , then

(a)  $2n = m(n^2 - 1)$       (b)  $2m = n(m^2 - 1)$

(c)  $2n = m(m^2 - 1)$       (d) None of these

4. If  $\cot\theta + \tan\theta = m$  and  $\sec\theta - \cos\theta = n$ , then which of the following is correct?

(a)  $m(mn^2)^{1/3} - n(nm^2)^{1/3} = 1$

(b)  $m(m^2n)^{1/3} - n(nm^2)^{1/3} = 1$

(c)  $n(mn^2)^{1/3} - m(nm^2)^{1/3} = 1$

(d)  $n(m^2n)^{1/3} - m(m^2n)^{1/3} = 1$

5. If  $a \cos\theta + b \sin\theta = m$  and  $a \sin\theta - b \cos\theta = n$ , then  $a^2 + b^2 =$

(a)  $m + n$

(b)  $m^2 - n^2$

(c)  $m^2 + n^2$

(d) None of these

6. If  $\tan\theta + \sin\theta = m$  and  $\tan\theta - \sin\theta = n$ , then

(a)  $m^2 - n^2 = 4mn$

(b)  $m^2 + n^2 = 4mn$

(c)  $m^2 - n^2 = m^2 + n^2$       (d)  $m^2 - n^2 = 4\sqrt{mn}$

7. If  $x = \sec\phi - \tan\phi$ ,  $y = \operatorname{cosec}\phi + \cot\phi$ , then

(a)  $x = \frac{y+1}{y-1}$

(b)  $x = \frac{y-1}{y+1}$

(c)  $y = \frac{1-x}{1+x}$

(d) None of these

8. If  $p = \frac{2 \sin\theta}{1 + \cos\theta + \sin\theta}$ , and  $q = \frac{\cos\theta}{1 + \sin\theta}$ , then

(a)  $pq = 1$

(b)  $\frac{q}{p} = 1$

(c)  $q - p = 1$

(d)  $q + p = 1$

9. If  $\tan\theta - \cot\theta = a$  and  $\sin\theta + \cos\theta = b$ , then  $(b^2 - 1)^2(a^2 + 4)$  is equal to

(a) 2

(b) -4

(c)  $\pm 4$

(d) 4

**Answer Keys**

1. (c)      2. (b)      3. (b)      4. (a)      5. (c)      6. (d)      7. (b)      8. (d)      9. (d)

### ■ MAXIMUM AND MINIMUM VALUES OF TRIGONOMETRIC FUNCTIONS

**Case I:** As we have already discussed in previous articles that  $-1 \leq \sin x \leq 1$  and  $-1 \leq \cos x \leq 1$ . If there is a trigonometrical function of the form  $a \sin x + b \cos x$ , then by putting  $a = r \cos\theta$ ,  $b = r \sin\theta$ , we have,

$$\begin{aligned} a \sin x + b \cos x &= r \cos\theta \sin x + r \sin\theta \cos x \\ &= r (\cos\theta \sin x + \sin\theta \cos x) \\ &= r \sin(x + \theta), \end{aligned}$$

where  $r = \sqrt{a^2 + b^2}$ ,  $\tan\theta = b/a$

since,  $-1 \leq \sin(x + \theta) \leq 1$

$$\therefore -r \leq r \sin(x + \theta) \leq r$$

or  $-\sqrt{a^2 + b^2} \leq a \sin x + b \cos x \leq \sqrt{a^2 + b^2}$  for all  $x$

Hence the maximum and minimum values of trigonometrical functions of the form  $a \sin x + b \cos x$  are  $\sqrt{a^2 + b^2}$  and  $-\sqrt{a^2 + b^2}$  respectively.

**NOTE**

$$|a \cos A + b \sin A| \leq \sqrt{a^2 + b^2}. \quad \text{e.g., } \cos A \pm \sin A = \sqrt{2} \sin \left( \frac{\pi}{4} \pm A \right) = \sqrt{2} \cos \left( A \mp \frac{\pi}{4} \right) \leq \sqrt{2}$$

**ILLUSTRATION 46:** Find the maximum and minimum value of the following expressions:

(a)  $3 \sin x + 4 \cos x$                       (b)  $4 \sin x - 3 \cos x + 2$

**SOLUTION:** (a) Let  $y = 3 \sin x + 4 \cos x = 5 \left[ \frac{3}{5} \sin x + \frac{4}{5} \cos x \right] = 5 \cos(x - \alpha)$ , where  $\cos \alpha = \frac{4}{5}$ ,  $\sin \alpha = \frac{3}{5}$

$$\Rightarrow -1 \leq \cos(x - \alpha) \leq 1 \Rightarrow -5 \leq 5 \cos(x - \alpha) \leq 5$$

$$\Rightarrow y_{\max} = 5 \text{ and } y_{\min} = -5$$

(b) Similarly, for  $y = 4 \sin x - 3 \cos x + 2 = 5 (\sin(x - \alpha)) + 2$

$$\Rightarrow y_{\max} = 5 + 2 = 7 \text{ and } y_{\min} = -5 + 2 = -3 \Rightarrow y \in [-3, 7]$$

**ILLUSTRATION 47:** Find the value of  $\lambda$  so that  $\lambda \sin x + \cos x = 3$  has at least one real solution.

**SOLUTION:** Let  $y = \lambda \sin x + \cos x = \sqrt{1 + \lambda^2} \left( \frac{\lambda}{\sqrt{1 + \lambda^2}} \sin x + \frac{1}{\sqrt{1 + \lambda^2}} \cos x \right)$

$$= \sqrt{1 + \lambda^2} (\sin \alpha \sin x + \cos \alpha \cos x); \text{ where } \frac{\sin \alpha}{\lambda} = \cos \alpha = \frac{1}{\sqrt{1 + \lambda^2}}$$

$$= \sqrt{1 + \lambda^2} \cos(x - \alpha) \Rightarrow -\sqrt{1 + \lambda^2} \leq y \leq \sqrt{1 + \lambda^2}$$

$$\Rightarrow y = 3 \text{ to have at least one real solution}$$

$$\Rightarrow -\sqrt{1 + \lambda^2} \leq 3 \leq \sqrt{1 + \lambda^2} \Rightarrow \sqrt{1 + \lambda^2} \geq 3 \Rightarrow 1 + \lambda^2 \geq 9 \Rightarrow \lambda^2 \geq 8$$

$$\Rightarrow \lambda \geq 2\sqrt{2} \text{ or } \lambda \leq -2\sqrt{2} \text{ i.e., } \lambda \in (-\infty, -2\sqrt{2}) \cup [2\sqrt{2}, \infty)$$

**ILLUSTRATION 48:** Find the maximum value of  $1 + \sin \left( \frac{\pi}{4} + \theta \right) + 2 \cos \left( \frac{\pi}{4} - \theta \right)$  for all real values of  $\theta$ .

**SOLUTION:** Given the expression;  $1 + \sin \left( \frac{\pi}{4} + \theta \right) + 2 \cos \left( \frac{\pi}{4} - \theta \right)$

$$= 1 + \frac{1}{\sqrt{2}} (\cos \theta + \sin \theta) + \sqrt{2} (\cos \theta + \sin \theta)$$

$$= 1 + \left( \frac{1}{\sqrt{2}} + \sqrt{2} \right) (\cos \theta + \sin \theta) = 1 + \left( \frac{1}{\sqrt{2}} + \sqrt{2} \right) \cdot \sqrt{2} \sin(\theta + \pi/4)$$

$$\therefore \text{ The maximum value equals } 1 + \left( \frac{1}{\sqrt{2}} + \sqrt{2} \right) \cdot \sqrt{2} = 4$$

**Case II:** In order to find out the maximum/minimum value of an expression  $f(x)$  in variable  $x$ . It is advisable to express  $f(x)$  applying the method of completing the square as below:

$$f(x) = (\phi(x))^2 + k \text{ where } k \text{ is a constant with respect to } x$$

Such that the minimum and maximum value of  $\phi(x)$  is known (say  $m$ ,  $M$  respectively) Therefore  $f(x)$  maximum will be equal to  $M^2 + k$  and  $f(x)$  minimum will be equal to  $k$  provided  $\phi(x)$  is capable of taking zero value

**NOTE**

Extreme values of the expressions are oftenly used in solving the trigonometric equations and inequations and determining the existence of real solutions.

**ILLUSTRATION 49:** Find the maximum and minimum values of the expression  $\sin^2 x + \operatorname{cosec}^2 x$ .

**SOLUTION:** Given the expression  $y = \sin^2 x + \operatorname{cosec}^2 x = (\sin x + \operatorname{cosec} x)^2 - 2 \Rightarrow y_{\min} = -2$  and  $y_{\max} = \infty$

**Warning:** Think again before presenting the answer! The above procedure has a serious mistake. Can you identify it?

$\sin x$  and  $\operatorname{cosec} x$  are of similar sign and reciprocal of each other. So  $(\sin x + \operatorname{cosec} x)$  can never be added to give zero. Hence  $y_{\min} \neq -2$ .

Completing the square in different manner:  $y = (\sin x - \operatorname{cosec} x)^2 + 2$  we conclude that:  $y_{\min} = 2$  obtained at  $x = (2n+1)\frac{\pi}{2}$  and  $y_{\max} = \infty$  when  $x$  approaches to  $n\pi$

**Aliter:**  $y_{\min}$  can also be obtain using inequality of mean (AM  $\geq$  GM)

$$\Rightarrow \frac{\sin^2 x + \operatorname{cosec}^2 x}{2} \geq \sqrt{\sin^2 x \cdot \operatorname{cosec}^2 x} \Rightarrow \sin^2 x + \operatorname{cosec}^2 x \geq 2$$

**ILLUSTRATION 50:** Find the range of the function  $f(x) = 16\sec^2 x + 9\operatorname{cosec}^2 x$ .

**SOLUTION:**

**Method I:** Applying AM  $\geq$  GM on  $16\sec^2 x$  and  $9\operatorname{cosec}^2 x$ ; we get

$$\begin{aligned} \frac{16\sec^2 x + 9\operatorname{cosec}^2 x}{2} &\geq \sqrt{16\sec^2 x \times 9\operatorname{cosec}^2 x} = 12\sqrt{\frac{1}{\sin^2 x \cos^2 x}} = 24\frac{1}{|\sin 2x|} \\ \Rightarrow 16\sec^2 x + 9\operatorname{cosec}^2 x &\geq \frac{48}{|\sin 2x|} \text{ Now max value of } |\sin 2x| = 1 \text{ and min value } \geq \frac{48}{|\sin 2x|} = 48 \\ &\text{and hence we get } 16\sec^2 x + 9\operatorname{cosec}^2 x \geq 48 \end{aligned}$$

**Method II:** Applying AM  $\geq$  GM on 3 numbers; 25,  $16\tan^2 x$ ,  $9\cot^2 x$  as  $16\sec^2 x + 9\operatorname{cosec}^2 x = 25 + 16\tan^2 x + 9\cot^2 x$

$$\text{We get } \frac{25 + 16\tan^2 x + 9\cot^2 x}{3} \geq \sqrt[3]{25 \times 16\tan^2 x \cdot 9\cot^2 x}$$

$$\text{and } 25 + 16\tan^2 x + 9\cot^2 x \geq 3 \times 5^{2/3} \times 2^{4/3} \times 3^{2/3} = (3)^{5/3} \cdot (2)^{4/3} \cdot (5)^{2/3} = (97200)^{1/3}$$

**Method III:**  $16\sec^2 x + 9\operatorname{cosec}^2 x = 16 + 16\tan^2 x + 9 + 9\cot^2 x = 25 + 16\tan^2 x + 9\cot^2 x$

Now applying AM  $\geq$  GM on  $16\tan^2 x$ ,  $9\cot^2 x$ , we get

$$\frac{16\tan^2 x + 9\cot^2 x}{2} \geq \sqrt{16\tan^2 x \times 9\cot^2 x} = 12$$

$$\Rightarrow 16\tan^2 x + 9\cot^2 x \geq 24 \Rightarrow 25 + 16\tan^2 x + 9\cot^2 x \geq 49$$

**Note:** From these three solutions methods, we are getting three different answers for the range of  $f(x)$ .

From method I, we get Range =  $[48, \infty)$

From method II, we get Range =  $[(97200)^{1/3}, \infty)$

From method III; we get Range =  $[49, \infty)$

Now, obviously only one of the above answers is correct and that is  $[49, \infty)$  from the method III.

**Reasons**

**(i) In method I:**  $f(x) \geq \frac{48}{|\sin 2x|}$  Minimum value of  $f(x) = 48$  when  $|\sin 2x| = 1$

i.e.,  $x = \pi/4$ . But at  $x = \pi/4$ ,  $16\sec^2 x$  becomes equal to 32 and  $9\operatorname{cosec}^2 x$  becomes equal to 18

So  $f(x)$  at  $x = \frac{\pi}{4} = 50$  which is obviously greater than 48 so equality does not hold true. And

hence we get only the lower bound of the function  $f(x)$  but not the minimum value.

**(ii) In method II:** We know that AM = GM only when all the terms are equal i.e.,  $25 = 16\tan^2 x = 9\cot^2 x$  which is not possible for any value of  $x$ .

$\therefore f(x)$  cannot be equal to  $(97200)^{1/3}$

and hence, here also we get only the lower bound of  $f(x)$  but not the minimum value.

**(iii) In method III:** We take AM  $\geq$  GM on  $16 \tan^2 x$  and  $9 \cot^2 x$  only

And the minimum value of  $f(x)$  is equal to 49 which is achieved when  $16 \tan^2 x = 9 \cot^2 x$  or we

can say that  $f(x)$  achieves its minimum value at all the points where  $|\tan x| = \left| \frac{\sqrt{3}}{2} \right|$ .

So we must be extra careful when we apply the inequality AM  $\geq$  GM.

## TEXTUAL EXERCISE-7 (OBJECTIVE)

- The smallest value of  $5 \cos \theta + 12$  is  
(a) 5 (b) 12  
(c) 7 (d) 17
- The maximum value of  $3 \cos x + 4 \sin x + 5$  is  
(a) 5 (b) 6  
(c) 7 (d) None of these
- The maximum value of  $4 \sin^2 x + 3 \cos^2 x$  is  
(a) 1 (b) 2  
(c) 3 (d) 4
- If  $y = \cos^2 x + \sec^2 x$ , then  
(a)  $y \leq 2$  (b)  $y \leq 1$   
(c)  $y \geq 2$  (d)  $1 < y < 2$
- The maximum value of  $5 \cos \theta + 3 \cos \left( \theta + \frac{\pi}{3} \right) + 3$  is  
(a) 5 (b) 11  
(c) 10 (d) -1
- The maximum value of  $\sin \left( x + \frac{\pi}{6} \right) + \cos \left( x + \frac{\pi}{6} \right)$  in the interval  $\left( 0, \frac{\pi}{2} \right)$  is attained at  
(a)  $x = \pi/12$  (b)  $x = \pi/6$   
(c)  $x = \pi/3$  (d)  $x = \pi/2$
- The expression  $\tan^2 \alpha + \cot^2 \alpha$  is  
(a)  $\geq 2$  (b)  $\leq 2$   
(c)  $\geq -2$  (d) None of these
- The maximum value of  $\cos^2 \left( \frac{\pi}{3} - x \right) - \cos^2 \left( \frac{\pi}{3} + x \right)$  is  
(a)  $-\sqrt{3}/2$  (b)  $1/2$   
(c)  $\sqrt{3}/2$  (d)  $3/2$
- Minimum value of  $\frac{1}{3 \sin \theta - 4 \cos \theta + 7}$  is  
(a)  $\frac{1}{12}$  (b)  $\frac{5}{12}$   
(c)  $\frac{7}{12}$  (d)  $\frac{1}{6}$
- Maximum value of  $\frac{1}{3 \sin \theta - 4 \cos \theta + 7}$  is  
(a)  $\frac{1}{12}$  (b)  $\frac{1}{6}$   
(c)  $\frac{1}{2}$  (d) infinite

11. The number of values of  $x$  for which  $f(x) = \cos x + \cos(\sqrt{2}x)$  attains its maximum values is  
 (a) 0 (b) 1  
 (c) 2 (d) infinite
12. The number of values of  $x$  for which  $f(x) = \cos x + \cos(\sqrt{2}x)$  attains its minimum values is  
 (a) 0 (b) 1  
 (c) 2 (d) infinite
13. The maximum value of  $4\sin^2 x - 12\sin x + 7$  is  
 (a) 25 (b) 4  
 (c) does not exist (d) None of these

## Answer Keys

1. (c) 2. (d) 3. (d) 4. (c) 5. (c) 6. (a) 7. (a) 8. (c) 9. (a) 10. (c)  
 11. (b) 12. (b) 13. (d)

### APPLICATION OF THEORY OF EQUATION

#### Applications Based on Quadratic Equation

- As we know,  $ax^2 + bx + c = 0$ , represents the quadratic equation with roots  $\alpha, \beta$ , then

$\alpha + \beta = \frac{-b}{a}$ ;  $\alpha \cdot \beta = \frac{c}{a}$  so the roots can be given as below:

$$\alpha = \frac{-b + \sqrt{b^2 - 4ac}}{2a} \text{ and } \beta = \frac{-b - \sqrt{b^2 - 4ac}}{2a}$$

and if we want to form quadratic equation whose roots are given as  $\alpha, \beta$ .

$$\Rightarrow x^2 - (\text{sum of the roots})x + (\text{product of the roots}) = 0.$$

$$\text{or } x^2 - (\alpha + \beta)x + \alpha \cdot \beta = 0$$

- If  $\alpha, \beta$  be the root of the quadratic equation  $ax^2 + bx + c = 0$  .....(i) then
- (a) The quadratic equation whose roots are  $p\alpha + q$  and  $p\beta + q$  can be obtained by replacing  $x$  by  $\frac{x-q}{p}$  in equation (i)
- (b) Quadratic equation with root  $p\alpha^2 + q$  and  $p\beta^2 + q$  can be obtained by replacing  $x$  by  $\pm\sqrt{\frac{x-q}{p}}$  in equation (i) and then simplifying the expression.

**ILLUSTRATION 51:** If  $ABCD$  is a convex quadrilateral such that  $3 \sec \alpha - 5 = 0$ , then find the quadratic equation whose roots are  $\tan \alpha$  and  $\operatorname{cosec} \alpha$ .

**SOLUTION:**  $\sec \alpha = 5/3$ . so  $\alpha \in (0, \pi/2)$

Hence  $\tan \alpha = 4/3$  and  $\operatorname{cosec} \alpha = 5/4$

$\therefore$  the required quadratic equation is:  $\Rightarrow x^2 - \left(\frac{4}{3} + \frac{5}{4}\right)x + \left(\frac{4}{3}\right) \times \frac{5}{4} = 0$

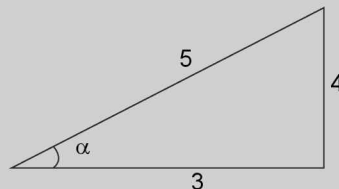

FIGURE 1.57

$$\Rightarrow x^2 - \frac{31}{12}x - \frac{20}{12} = 0 \quad \text{or} \quad 12x^2 - 31x + 20 = 0$$

**ILLUSTRATION 52:** If  $\sec\alpha$  and  $\operatorname{cosec}\alpha$  are the roots of  $x^2 - px + q = 0$ , then show  $p^2 = q(q + 2)$ .

**SOLUTION:** Since  $\sec\alpha$  and  $\operatorname{cosec}\alpha$  are the roots of  $x^2 - px + q = 0$

$$\therefore \sec\alpha + \operatorname{cosec}\alpha = p \text{ and } \sec\alpha \cdot \operatorname{cosec}\alpha = q$$

$$\Rightarrow \sin\alpha + \cos\alpha = p \sin\alpha \cdot \cos\alpha \text{ and } \sin\alpha \cdot \cos\alpha = 1/q$$

$$\Rightarrow \sin\alpha + \cos\alpha = p/q \quad \dots(i)$$

squaring both sides of (i), we get:  $\sin^2\alpha + \cos^2\alpha + 2 \sin\alpha \cos\alpha = p^2/q^2$

$$\Rightarrow 1 + 2 \sin\alpha \cdot \cos\alpha = \frac{p^2}{q^2} \Rightarrow 1 + \frac{2}{q} = \frac{p^2}{q^2} \Rightarrow p^2 = q(q + 2)$$

**ILLUSTRATION 53:** If  $0 \leq a \leq 3$ ,  $0 \leq b \leq 3$  and the equation  $x^2 + 4 + 3\cos(ax + b) = 2x$  has at least one solution, then find the value of  $(a + b)$ .

**SOLUTION:** Given equations can be written as:  $x^2 - 2x + 4 = -3 \cos(ax + b)$

$$\Rightarrow (x - 1)^2 + 3 = -3 \cos(ax + b) \quad \dots(i)$$

$$\text{As } -1 \leq \cos(ax + b) \leq 1 \text{ and } (x - 1)^2 \geq 0$$

$\therefore$  equation (i) has real solution iff

$$\cos(ax + b) = -1 \text{ and } (x - 1) = 0$$

$$\Rightarrow a + b = \pi, 3\pi, 5\pi, \dots \text{ (i.e., odd multiples of } \pi) \text{ but } a + b \in [0, 6] \Rightarrow a + b = \pi$$

**ILLUSTRATION 54:** Find the values of  $p$  if it satisfies  $\cos\theta = x + p/x$ ,  $x \in \mathbb{R}$  for all real values of  $\theta$ .

**SOLUTION:**  $x^2 - \cos\theta \cdot x + p = 0$

$$\Rightarrow x = \frac{\cos\theta \pm \sqrt{\cos^2\theta - 4p}}{2}, \text{ for real } x \cos^2\theta - 4p \geq 0$$

$$\Rightarrow 4p \leq \cos^2\theta \Rightarrow 4p \leq \cos^2\theta \leq 1 \Rightarrow p \leq 1/4 \text{ for all values of } \theta$$

## APPLICATION USING TRANSFORMATION OF EQUATIONS

Many conditional trigonometrical relations can be derived by applying the transformation of equation using symmetric

transformation of roots. To understand and command such applications, let us discuss some of the examples illustrated below:

**ILLUSTRATION 55:** If  $\sec\alpha$ ,  $\sec\beta$  and  $\sec\gamma$  are the roots of equation  $ax^3 + bx^2 + c = 0$ , then prove that

$$(a) (\sec\alpha - 1)(\sec\beta - 1)(\sec\gamma - 1) = -\left(\frac{a+b+c}{a}\right)$$

$$(b) \tan^2\alpha \cdot \tan^2\beta \cdot \tan^2\gamma = \left(\frac{b+c}{a}\right)^2 - 1$$

**SOLUTION:** (a) Since  $\sec\alpha$ ,  $\sec\beta$  and  $\sec\gamma$  are the roots of equation  $ax^3 + bx^2 + c = 0$  ....(i)

therefore the equation whose roots are  $(\sec\alpha - 1)$ ,  $(\sec\beta - 1)$ ,  $(\sec\gamma - 1)$  is obtained as:

$$a(x + 1)^3 + b(x + 1)^2 + c = 0$$

Since the product of roots of this equation is  $= -\frac{\text{constant term}}{a} = -\left(\frac{a+b+c}{a}\right)$

$$\Rightarrow (\sec\alpha - 1)(\sec\beta - 1)(\sec\gamma - 1) = -\left(\frac{a+b+c}{a}\right)$$

(b) The equation containing the roots of  $\sec^2\alpha - 1$ ,  $\sec^2\beta - 1$ ,  $\sec^2\gamma - 1$  can be obtained by replacing  $x$  with  $\pm\sqrt{x+1}$

$$\Rightarrow a (\pm\sqrt{x+1})^3 + b (\pm\sqrt{x+1})^2 + c = 0$$

$$\Rightarrow \pm a(x+1)(\sqrt{x+1}) + b(x+1) + c = 0 \text{ Squaring intelligently, we can get}$$

$$\Rightarrow a^2(x+1)^3 = b^2(x+1)^2 + 2bc(x+1) + c^2 \Rightarrow a^2(x+1)^3 - b^2(x+1)^2 - 2bc(x+1) - c^2 = 0$$

Therefore product of roots is given as

$$(\sec^2\alpha - 1) \cdot (\sec^2\beta - 1) \cdot (\sec^2\gamma - 1) = \frac{a^2 - b^2 - 2bc - c^2}{-a^2} = \left(\frac{b+c}{a}\right)^2 - 1$$

$$\Rightarrow \tan^2\alpha \cdot \tan^2\beta \cdot \tan^2\gamma = \left(\frac{b+c}{a}\right)^2 - 1$$

## TEXTUAL EXERCISE-16 (SUBJECTIVE)

- (a) Prove that  $\sin 18^\circ$  is the root of equation  $4x^2 + 2x - 1 = 0$  as well as the cubic equation  $4x^3 - 2x^2 - 3x + 1 = 0$  and hence or otherwise prove that  $4x^2 + 2x - 1$  is a factor of the expression  $4x^3 - 2x^2 - 3x + 1$ .  
(b) Prove that  $\cos 18^\circ$  is a root of equation  $16x^2 - 20x^2 + 5 = 0$ .
- Prove that the roots of the equation  $8x^3 - 4x^2 - 4x + 1 = 0$  are  $\cos \frac{\pi}{7}$ ,  $\cos \frac{3\pi}{7}$ ,  $\cos \frac{5\pi}{7}$  and hence show that

$$\sec \frac{\pi}{7} + \sec \frac{3\pi}{7} + \sec \frac{5\pi}{7} = 4 \text{ and deduce the equation}$$

$$\text{whose roots are } \tan^2 \frac{\pi}{7}, \tan^2 \frac{3\pi}{7}, \tan^2 \frac{5\pi}{7}.$$

- Using the results in Q. 2 or otherwise, prove that  $\tan \frac{\pi}{7} \cdot \tan \frac{2\pi}{7} \cdot \tan \frac{3\pi}{7} = \sqrt{7}$ .

## Answer Keys

2.  $y^3 - 21y^2 + 35y - 7 = 0$

## PROVING TRIGONOMETRIC INEQUALITIES

To prove/solve trigonometric inequalities, it is necessary to practice periodicity and monotonicity of functions and taking the help of graphical representation and application of certain concepts of functions and calculus, makes the process easy and time saving. Some of the applications are illustrated below.

### Jenson's Functional Equation and Inequality and Its Applications

We study Jenson's functional equation for the function which is increasing with constant rate of increase. It is

given as  $f\left(\frac{mx_1 + nx_2}{m+n}\right) = \frac{mf(x_1) + nf(x_2)}{m+n}$  where  $m, n$  are constant real numbers.

### Discussions

If  $f'(x) > 0$  and  $f''(x) = 0 \forall x \in D_f$ , i.e., graph of  $f(x)$  increases with constant rate and neither concave up nor concave downward. ( $\because f''(x) = 0$ ).

$$\text{Therefore } f\left(\frac{mx_1 + nx_2}{m+n}\right) = \frac{mf(x_1) + nf(x_2)}{m+n}$$

( $\because$  AM = BM)



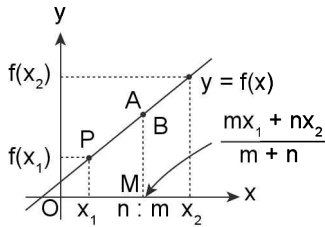

FIGURE 1.58

From here, Jensen derived two very useful deductions named as Jensen's inequality.

**Deduction 1: For increasing function with decreasing rate of increase:**

If  $f'(x) > 0$  and  $f''(x) < 0$  for all  $x \in D_f$  then the graph of  $f(x)$  increases with decreasing rate of increase and remain concave downward ( $\because f''(x) < 0$ ). Therefore chord of the curve lies below the curve. Considering a point B dividing chord PQ

in the ratio  $n : m$ , we get  $f\left(\frac{mx_1 + nx_2}{m+n}\right) > \frac{mf(x_1) + nf(x_2)}{m+n}$   
 ( $\because AM > BM$ )

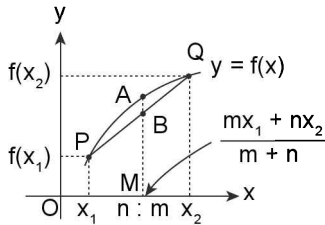

FIGURE 1.59

**Deduction 2: For increasing function with increasing rate of increase:**

If  $f'(x) > 0$  and  $f''(x) > 0$  for all  $x \in D_f$  i.e., graph of  $f(x)$  increases and remains concave up ( $\because f''(x) > 0$ ). Therefore chord of the curve lies above the curve. Considering a point B dividing chord PQ in the ratio  $n : m$ , we get

$$f\left(\frac{mx_1 + nx_2}{m+n}\right) < \frac{mf(x_1) + nf(x_2)}{m+n}$$

( $\because AM < BM$ ) (Similarly, you can think of the inequalities for decreasing functions)

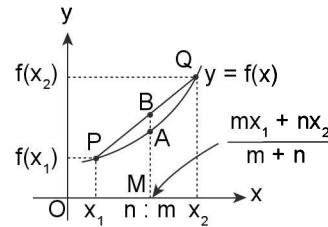

FIGURE 1.60

While proving an inequality we may also use the following concepts wherever applicable:

1. If a function  $f(x)$  is increasing for all  $x \in (a, b)$ , then  $x_2 > x_1 \Rightarrow f(x_2) > f(x_1)$  for all  $x_1, x_2 \in (a, b)$
2. If a function  $f(x)$  is decreasing for all  $x \in (a, b)$  then  $x_2 > x_1 \Rightarrow f(x_2) < f(x_1)$  for all  $x_1, x_2 \in (a, b)$
3. Inequality of means ( $AM \geq GM \geq HM$ ) and inequality of weighted means are also applied.

**ILLUSTRATION 56:** If  $0 < x < y < \pi/2$ , show that  $x - \sin x < y - \sin y$ .

**SOLUTION:** Let us consider a function  $f(x)$  defined as  $f(x) = x - \sin x$  for all  $x \in (0, \pi/2)$

Differentiating with respect to  $x$  we get

$$f'(x) = 1 - \cos x > 0 \text{ so } f(x) \text{ is monotonically increasing for all } x \in (0, \pi/2)$$

$$\text{So let } 0 < x < y < \pi/2 \Rightarrow f(x) < f(y)$$

$$\Rightarrow x - \sin x < y - \sin y.$$

**ILLUSTRATION 57:** If  $0 < A < \frac{\pi}{6}$ , then show  $A(\operatorname{cosec} A) < \frac{\pi}{3}$

**SOLUTION:** Here, graph for  $y = \sin x$  is shown below having points  $P(A, \sin A)$  and  $Q\left(\frac{\pi}{6}, \sin \frac{\pi}{6}\right)$  on it.

From adjoining figure; slope of  $OP >$  slope of  $OQ$

$$\Rightarrow \frac{\sin A - 0}{A - 0} > \frac{\sin \frac{\pi}{6} - 0}{\frac{\pi}{6} - 0} \Rightarrow \frac{\sin A}{A} > \frac{3}{\pi} \text{ or } \frac{A}{\sin A} < \frac{\pi}{3} \text{ or } A(\operatorname{cosec} A) < \frac{\pi}{3}$$

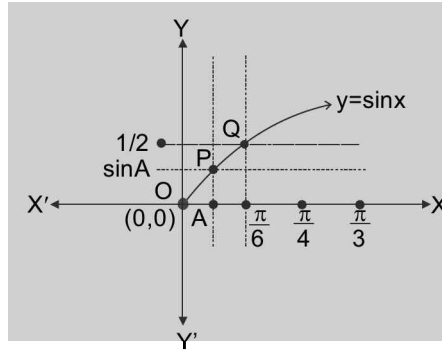
**FIGURE 1.61**

**ILLUSTRATION 58:** If  $A, B, C \in (-\pi/2, \pi/2)$ , then prove that  $\cos A + \cos B + \cos C \leq \frac{3}{2}$  or  $\sin A/2 \cdot \sin B/2 \cdot \sin C/2 \leq \frac{1}{8}$ .

**SOLUTION:** Since for a function which is concave downwards  $f\left(\frac{x_1 + x_2 + x_3}{3}\right) > \frac{f(x_1) + f(x_2) + f(x_3)}{3}$

and we know that the graph of  $y = \cos x$  is concave downwards for all  $x \in \left(-\frac{\pi}{2}, \frac{\pi}{2}\right)$ .

Let  $P(A, \cos A)$ ,  $Q(B, \cos B)$  and  $R(C, \cos C)$  be any three points on  $y = \cos x$  then it is clear from the graph  $GM \leq ML$ .

$$\Rightarrow \frac{\cos A + \cos B + \cos C}{3} \leq \cos\left(\frac{A+B+C}{3}\right) = \cos(\pi/3) = 1/2$$

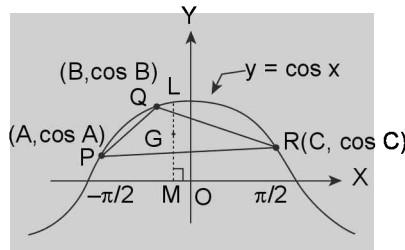
**FIGURE 1.62**

$$\therefore \cos A + \cos B + \cos C \leq 3/2$$

Since we know from the conditional trigonometric identities

$$\cos A + \cos B + \cos C = 1 + 4 \sin A/2 \sin B/2 \sin C/2$$

$$\Rightarrow 1 + 4 \sin A/2 \sin B/2 \sin C/2 \leq 3/2 \Rightarrow \sin A/2 \sin B/2 \sin C/2 \leq 1/8$$

We can also argue the same in the following manner:

$$\text{The centroid of } \Delta PQR \text{ is } G\left(\frac{A+B+C}{3}, \frac{\cos A + \cos B + \cos C}{3}\right)$$

Draw  $\perp$  GM on x-axis, meeting the curve at L  $\Rightarrow$  co-ordinates of L are

$$\left(\frac{A+B+C}{3}, \cos\left(\frac{A+B+C}{3}\right)\right) \text{ implying } GM \leq ML$$

**Aliter:** We have  $\sin A/2 \sin B/2 \sin C/2$

$$= \frac{1}{2} \left[ \cos \frac{A-B}{2} - \cos \frac{A+B}{2} \right] \sin \frac{C}{2} = \frac{1}{2} \left[ \cos \frac{A-B}{2} - \sin \frac{C}{2} \right] \sin \frac{C}{2} \leq \frac{1}{2} \left[ 1 - \sin \frac{C}{2} \right] \sin \frac{C}{2}$$

$$= \frac{1}{2} \left[ \sin \frac{C}{2} - \sin^2 \frac{C}{2} \right] = \frac{1}{2} \left[ \frac{1}{4} - \left( \frac{1}{2} - \sin \frac{C}{2} \right)^2 \right] \leq \frac{1}{8}$$

The equality holds good iff  $\cos \frac{A-B}{2} = 1$  and  $\sin \frac{C}{2} = \frac{1}{2}$

which happens iff  $A = B = C (= 60^\circ)$

### TEXTUAL EXERCISE-17 (SUBJECTIVE)

1. If  $A, B, C$  are angles of an acute angled triangle, then prove that

(a)  $\sec^2 \left( \frac{\pi}{6} + \frac{A}{4} \right) + \sec^2 \left( \frac{\pi}{4} + \frac{B}{4} \right) + \sec^2 \left( \frac{\pi}{3} + \frac{C}{4} \right) > 3.$

(b)  $A \operatorname{cosec} A + B \operatorname{cosec} B + C \operatorname{cosec} C < \frac{3\pi}{2}$

2. If  $A, B, C$  are the angle of a triangle, then show that  $\sin A + \sin B + \sin C < 3\sqrt{3}/2.$

### SUMMATION OF SERIES CONTAINING SINE AND COSINE OF ANGLES FORMING AN AP

#### Sine of Angle Forming an AP

Let the series be  $S = \sin \alpha + \sin (\alpha + \beta) + \sin (\alpha + 2\beta) + \dots + \sin \{ \alpha + (n-1)\beta \}$

Since the angles  $\alpha, \alpha + \beta, \alpha + 2\beta, \dots, \{ \alpha + (n-1)\beta \}$  are in A.P. with  $1^{\text{st}}$  term  $\alpha$  and common difference  $\beta$ . Let us denote the required summation by  $S$ .

Since we know that

$$2 \sin \alpha \sin \frac{\beta}{2} = \cos \left( \alpha - \frac{\beta}{2} \right) - \cos \left( \alpha + \frac{\beta}{2} \right)$$

$$\Rightarrow 2 \sin (\alpha + \beta) \sin \frac{\beta}{2} = \cos \left( \alpha + \frac{\beta}{2} \right) - \cos \left( \alpha + \frac{3\beta}{2} \right)$$

$$\Rightarrow 2 \sin (\alpha + 2\beta) \sin \frac{\beta}{2} = \cos \left( \alpha + \frac{3\beta}{2} \right) - \cos \left( \alpha + \frac{5\beta}{2} \right)$$

.....

$$2 \sin (\alpha + (n-2)\beta) \sin \frac{\beta}{2} = \cos \left\{ \alpha + \left( n - \frac{5}{2} \right) \beta \right\} - \cos \left\{ \alpha + \left( n - \frac{3}{2} \right) \beta \right\}$$

$$\text{and } 2 \sin (\alpha + (n-1)\beta) \sin \frac{\beta}{2} = \cos \left\{ \alpha + \left( n - \frac{3}{2} \right) \beta \right\} - \cos \left\{ \alpha + \left( n - \frac{1}{2} \right) \beta \right\}$$

By adding together  $n$  relations, we get

$$2 \sin \frac{\beta}{2} \cdot S = \cos \left( \alpha - \frac{\beta}{2} \right) - \cos \left\{ \alpha + \left( n - \frac{1}{2} \right) \beta \right\}$$

Since all other terms of RHS cancel each other

$$\Rightarrow 2 \sin \frac{\beta}{2} \cdot S = 2 \sin \left\{ \alpha + \left( \frac{n-1}{2} \right) \beta \right\} \sin \frac{n\beta}{2}$$

$$\Rightarrow S = \frac{\sin \left\{ \alpha + \left( \frac{n-1}{2} \right) \beta \right\} \sin \frac{n\beta}{2}}{\sin \frac{\beta}{2}}$$

So we conclude that:

$$\sin (\alpha) + \sin (\alpha + \beta) + \sin (\alpha + 2\beta) + \dots + \sin (\alpha + (n-1)\beta)$$

$$= \frac{\sin \{ \alpha + (n-1)(\beta/2) \} \cdot \sin (n\beta/2)}{\sin (\beta/2)} \quad \dots(A)$$

**NOTES**

1. Since above expression vanishes when  $\sin \frac{n\beta}{2}$  is zero, i.e., when  $\frac{n\beta}{2}$  is equal to an integral multiple of  $\pi$ .

So  $\frac{n\beta}{2} = k\pi$ , where  $k$  is any integer i.e.,  $\beta = k \cdot \frac{2\pi}{n}$ . Hence the sum of the sines of  $n$  angles, which are in arithmetical progression, vanishes when the common difference of the angles is any multiple of  $\frac{2\pi}{n}$  e.g.,

$$\sin \alpha + \sin \left( \alpha + \frac{2\pi}{n} \right) + \sin \left( \alpha + \frac{4\pi}{n} \right) + \sin \left( \alpha + \frac{6\pi}{n} \right) + \dots \text{to } n \text{ terms} = 0$$

2. By putting  $\beta = 2\alpha$  in result (A) we have

$$\sin \alpha + \sin 3\alpha + \sin 5\alpha + \dots + \sin (2n-1)\alpha = \frac{\sin\{\alpha + (n-1)\alpha\} \sin n\alpha}{\sin \alpha} = \frac{\sin^2 n\alpha}{\sin \alpha}$$

**■ COSINE OF ANGLE FORMING AN AP**

Let the series be  $S = \cos \alpha + \cos (\alpha + \beta) + \cos (\alpha + 2\beta) + \dots + \cos \{\alpha + (n-1)\beta\}$

Since the angles be  $\alpha, \alpha + \beta, \alpha + 2\beta, \dots, \{\alpha + (n-1)\beta\}$  are in AP with 1st term  $\alpha$  and common difference  $\beta$ . Let us denote the required summation by  $S$ . and  $S \equiv \cos \alpha + \cos (\alpha + \beta) + \cos (\alpha + 2\beta) + \dots + \cos \{\alpha + (n-1)\beta\}$

Since we know that

$$2 \cos \alpha \sin \frac{\beta}{2} = \sin \left( \alpha + \frac{\beta}{2} \right) - \sin \left( \alpha - \frac{\beta}{2} \right)$$

$$\Rightarrow 2 \cos (\alpha + \beta) \sin \frac{\beta}{2} = \sin \left( \alpha + \frac{3\beta}{2} \right) - \sin \left( \alpha + \frac{\beta}{2} \right)$$

$$\Rightarrow 2 \cos (\alpha + 2\beta) \sin \frac{\beta}{2} = \sin \left( \alpha + \frac{5\beta}{2} \right) - \sin \left( \alpha + \frac{3\beta}{2} \right)$$

$$\dots \dots \dots$$

$$2 \cos (\alpha + (n-2)\beta) \sin \frac{\beta}{2} = \sin \left\{ \alpha + \left( n - \frac{3}{2} \right) \beta \right\} - \sin \left\{ \alpha + \left( n - \frac{5}{2} \right) \beta \right\}$$

$$\text{and } 2 \cos (\alpha + (n-1)\beta) \sin \frac{\beta}{2} = \sin \left\{ \alpha + \left( n - \frac{1}{2} \right) \beta \right\} - \sin \left\{ \alpha + \left( n - \frac{3}{2} \right) \beta \right\}$$

By adding together these  $n$  lines, we have

$$2 \sin \frac{\beta}{2} \cdot S = \sin \left\{ \alpha + \left( n - \frac{1}{2} \right) \beta \right\} - \sin \left( \alpha - \frac{\beta}{2} \right)$$

(∵ the other terms on the right hand sides cancel one another).

$$\Rightarrow 2 \sin \frac{\beta}{2} \cdot S = 2 \cos \left\{ \alpha + \left( \frac{n-1}{2} \right) \beta \right\} \sin \frac{n\beta}{2}$$

$$\text{i.e., } S = \frac{\cos \left\{ \alpha + \left( \frac{n-1}{2} \right) \beta \right\} \sin \frac{n\beta}{2}}{\sin \frac{\beta}{2}}$$

So we conclude that:  $\cos (\alpha) + \cos (\alpha + \beta) + \cos (\alpha + 2\beta) + \dots + \cos (\alpha + (n-1)\beta)$

$$= \frac{\cos \{\alpha + (n-1)(\beta/2)\} \cdot \sin(n\beta/2)}{\sin(\beta/2)} \quad \dots(B)$$

**NOTE**

Since the above expression vanishes when  $\sin \frac{n\beta}{2}$  is zero, i.e., when  $\frac{n\beta}{2}$  is equal to any multiple of  $\pi$ . i.e., when  $\frac{n\beta}{2} = k\pi$ , where  $k$  is any integer and when  $\beta = k \cdot \frac{2\pi}{n}$ . Hence the sum of the cosines of  $n$  angles, which are in arithmetical progression, vanishes when the common difference of the angles is any multiple of  $\frac{2\pi}{n}$

e.g.,  $\cos \alpha + \cos \left( \alpha + \frac{2\pi}{n} \right) + \cos \left( \alpha + \frac{4\pi}{n} \right) + \dots \text{to } n \text{ terms} = 0$

**APPLICATION OF COMPLEX NUMBERS FOR SUM OF TRIGONOMETRIC SERIES**

Above results can also be proved very conveniently using the concept of complex numbers as illustrated below:

Let  $S = \sin \alpha + \sin (\alpha + \beta) + \sin (\alpha + 2\beta) + \dots + \sin \{ \alpha + (n-1)\beta \}$  ... (A)

and  $C = \cos \alpha + \cos (\alpha + \beta) + \cos (\alpha + 2\beta) + \dots + \cos \{ \alpha + (n-1)\beta \}$  ... (B)

Multiplying  $A$  by  $i$  and adding  $B$  to it, gives

$$C + iS = (\cos \alpha + i \sin \alpha) + (\cos(\alpha + \beta) + i \sin(\alpha + \beta)) + \dots + \cos\{\alpha + (n-1)\beta\} + i \sin\{\alpha + (n-1)\beta\}$$

$$= e^{i\alpha} + e^{i(\alpha+\beta)} + e^{i(\alpha+2\beta)} + \dots + e^{i(\alpha+(n-1)\beta)}$$

$$= e^{i\alpha} [1 + e^{i\beta} + (e^{i\beta})^2 + (e^{i\beta})^3 + \dots + (e^{i\beta})^{n-1}]$$

The series in the bracket is a GP of  $n$  terms with 1st term 1 and common ratio  $= e^{i\beta}$

$$= e^{i\alpha} \left[ \frac{(e^{i\beta})^n - 1}{e^{i\beta} - 1} \right] = e^{i\alpha} \left[ \frac{(\cos n\beta - 1) + i \sin n\beta}{\cos \beta - 1 + i \sin \beta} \right]$$

$$= e^{i\alpha} \left[ \frac{2i^2 \sin^2 \frac{n\beta}{2} + 2i \sin \frac{n\beta}{2} \cos \frac{n\beta}{2}}{2i^2 \sin^2 \frac{\beta}{2} + 2i \sin \frac{\beta}{2} \cos \frac{\beta}{2}} \right]$$

$$= e^{i\alpha} \left[ \frac{2i \sin \frac{n\beta}{2}}{2i \sin \frac{\beta}{2}} \left( \frac{\cos \frac{n\beta}{2} + i \sin \frac{n\beta}{2}}{\cos \frac{\beta}{2} + i \sin \frac{\beta}{2}} \right) \right]$$

$$= \frac{e^{i\alpha} \sin \frac{n\beta}{2}}{\sin \frac{\beta}{2}} \left( e^{\frac{i(n-1)\beta}{2}} \right) = \frac{\sin \frac{n\beta}{2}}{\sin \frac{\beta}{2}} \left[ e^{i\left(\alpha + \frac{(n-1)\beta}{2}\right)} \right]$$

Let  $\alpha + \frac{(n-1)\beta}{2} = \phi$  and  $\frac{\sin \frac{n\beta}{2}}{\sin \frac{\beta}{2}} = \lambda$

$\Rightarrow C + iS = \lambda(\cos \phi + i \sin \phi)$

Comparing the real and imaginary parts of both sides, we get

$$C = \frac{\sin \frac{n\beta}{2} \cdot \cos \left( \alpha + \frac{(n-1)\beta}{2} \right)}{\sin \frac{\beta}{2}}$$

$$S = \frac{\sin \frac{n\beta}{2} \cdot \sin \left( \alpha + \frac{(n-1)\beta}{2} \right)}{\sin \frac{\beta}{2}}$$

**ILLUSTRATION 59:** Find the sum of  $\sin \alpha - \sin (\alpha + \beta) + \sin (\alpha + 2\beta) - \dots$  to  $n$  terms.

**SOLUTION:** We have  $\sin(\alpha + \beta + \pi) = -\sin(\alpha + \beta)$

$$\sin(\alpha + 2\beta + 2\pi) = \sin(\alpha + 2\beta)$$

$$\sin(\alpha + 3\beta + 3\pi) = -\sin(\alpha + 3\beta)$$

.....

Hence the series  $\sin \alpha + \sin(\alpha + \beta + \pi) + \sin \{ \alpha + 2(\beta + \pi) \} + \sin \{ \alpha + 3(\beta + \pi) \} + \dots$

$$= \frac{\sin \left\{ \alpha + \frac{n-1}{2}(\beta + \pi) \right\} \sin \frac{n(\beta + \pi)}{2}}{\sin \frac{\beta + \pi}{2}} = \frac{\sin \left\{ \alpha + \frac{n-1}{2}(\beta + \pi) \right\} \sin \frac{n(\beta + \pi)}{2}}{\cos \frac{\beta}{2}}$$

**ILLUSTRATION 60:** Sum the series:  $\sqrt{1 + \cos \alpha} + \sqrt{1 + \cos 2\alpha} + \sqrt{1 + \cos 3\alpha} + \dots$  to  $n$  terms for  $\alpha \in \left[ \frac{-\pi}{n}, \frac{\pi}{n} \right]$

**SOLUTION:** Here,  $\sqrt{1 + \cos \alpha} + \sqrt{1 + \cos 2\alpha} + \sqrt{1 + \cos 3\alpha} + \dots + \sqrt{1 + \cos n\alpha}$

$$= \sqrt{2 \cos^2 \frac{\alpha}{2}} + \sqrt{2 \cos^2 \alpha} + \sqrt{2 \cos^2 \frac{3\alpha}{2}} + \dots \text{to } n \text{ terms}$$

$$= \sqrt{2} \left\{ \cos \frac{\alpha}{2} + \cos \frac{2\alpha}{2} + \cos \frac{3\alpha}{2} + \dots + \text{to } n \text{ terms} \right\}$$

$$\begin{aligned}
 &= \sqrt{2} \frac{\sin \frac{n\alpha}{4}}{\sin \frac{\alpha}{4}} \cdot \cos \left\{ \frac{\frac{\alpha}{2} + \frac{n\alpha}{2}}{2} \right\} \quad (\text{using formula}) \\
 &= \sqrt{2} \frac{\sin \frac{n\alpha}{4}}{\sin \frac{\alpha}{4}} \cos \left\{ (n+1) \frac{\alpha}{4} \right\}
 \end{aligned}$$

**ILLUSTRATION 61:** Find the sum to series  $\cos \alpha \sin \beta + \cos 3\alpha \sin 2\beta + \cos 5\alpha \sin 3\beta + \dots$  to  $n$  terms.

**SOLUTION:** Let  $S$  denote the given series

$$\begin{aligned}
 \text{Then } 2S &= \{\sin(\alpha + \beta) - \sin(\alpha - \beta)\} + \{\sin(3\alpha + 2\beta) - \sin(3\alpha - 2\beta)\} \\
 &+ \{\sin(5\alpha + 3\beta) - \sin(5\alpha - 3\beta)\} + \dots \\
 &= \{\sin(\alpha + \beta) + \sin(3\alpha + 2\beta) + \sin(5\alpha + 3\beta) + \dots \text{ to } n \text{ terms}\} \\
 &\quad - \{\sin(\alpha - \beta) + \sin(3\alpha - 2\beta) + \sin(5\alpha - 3\beta) + \dots \text{ to } n \text{ terms}\} \\
 &= \frac{\sin \left\{ (\alpha + \beta) + \frac{n-1}{2}(2\alpha + \beta) \right\} \sin n \frac{2\alpha + \beta}{2}}{\sin \frac{2\alpha + \beta}{2}} - \frac{\sin \left\{ (\alpha - \beta) + \frac{n-1}{2}(2\alpha - \beta) \right\} \sin n \frac{2\alpha - \beta}{2}}{\sin \frac{2\alpha - \beta}{2}} \\
 &= \frac{\sin \left\{ n\alpha + \frac{n+1}{2}\beta \right\} \sin n \frac{2\alpha + \beta}{2}}{\sin \frac{2\alpha + \beta}{2}} - \frac{\sin \left\{ n\alpha - \frac{n+1}{2}\beta \right\} \sin n \frac{2\alpha - \beta}{2}}{\sin \frac{2\alpha - \beta}{2}}
 \end{aligned}$$

## TEXTUAL EXERCISE-18 (SUBJECTIVE)

1. Sum the following series

(a)  $\cos \theta + \cos 3\theta + \cos 5\theta + \dots$  to  $n$  terms.

(b)  $\cos \frac{A}{2} + \cos 2A + \cos \frac{7A}{2} + \dots$  to  $n$  terms.

2. Prove that

$$\frac{\sin a + \sin 2a + \sin 3a + \dots + \sin na}{\cos a + \cos 2a + \dots + \cos na} = \tan \frac{n+1}{2} a$$

3. Sum the series  $\cos \frac{\pi}{2n+1} + \cos \frac{3\pi}{2n+1} + \cos \frac{5\pi}{2n+1} + \dots$  to  $n$  terms.

4. Sum the series  $\cos a - \cos(a + \beta) + \cos(a + 2\beta) - \dots$  to  $2n$  terms.

5. Sum the series  $\cos a \sin 2a + \sin 2a \cos 3a + \cos 3a \sin 4a + \sin 4a \cos 5a \dots$  to  $2n$  terms.

6. Sum the series  $\sin^2 a + \sin^2 2a + \sin^2 3a + \dots$  to  $n$  terms.

## Answer Keys

1. (a)  $\frac{1}{2} \sin 2n\theta \operatorname{cosec} \theta$  (b)  $\cos \frac{3n-1}{4} A \sin \frac{3n}{4} A \operatorname{cosec} \frac{3}{4} A$

3.  $1/2$

4.  $\sin \left[ \alpha + \left( n - \frac{1}{2} \right) \beta \right] \sin n\beta \sec \frac{\beta}{2}$  5.  $\frac{1}{2} \sin(2n+2)\alpha \cdot \sin 2n\alpha \cdot \operatorname{cosec} \alpha$  6.  $\frac{1}{4} [(2n+1) \sin \alpha - \sin(2n+1)\alpha] \operatorname{cosec} \alpha$

### ■ SERIES CONTAINING PRODUCT OF COSINE OF THE ANGLES FORMING A GP

The trigonometric series containing product of the cosines of the angles such that the angles are in geometric progression is given as:

$$\cos A \cos 2A \cos 2^2 A \cos 2^3 A \dots \cos 2^{n-1} A = \frac{\sin 2^n A}{2^n \sin A}$$

**Proof:** Multiply and divide by  $2\sin A$  in the left hand side of the expression

$$\begin{aligned} \text{LHS} &= \frac{2 \sin A}{2 \sin A} \times \cos A \cos 2A \cos 2^2 A \cos 2^3 A \dots \cos 2^{n-1} A \\ &= \frac{2 \sin 2A \cos 2A \cos 2^2 A \cos 2^3 A \dots \cos 2^{n-1} A}{2^2 \sin A} \\ &= \frac{2 \sin 2^2 A \cos 2^2 A \cos 2^3 A \dots \cos 2^{n-1} A}{2^3 \sin A} \end{aligned}$$

proceeding similarly, the expression converges to:

$$\text{LHS} = \frac{2 \sin 2^{n-1} A \cos 2^{n-1} A}{2^n \sin A} = \frac{\sin 2^n A}{2^n \sin A}$$

### NOTES

When  $n \rightarrow \infty$ , the following relation can be established:

$$1. \cos \frac{\theta}{2} \cdot \cos \frac{\theta}{2^2} \cdot \cos \frac{\theta}{2^3} \dots \cos \frac{\theta}{2^{n-1}} \dots \infty = \frac{\sin \theta}{\theta}$$

2. The above equation when differentiated by taking natural log on both sides gives rise to many useful identities.

**ILLUSTRATION 62:** If  $\theta = \frac{\pi}{2^n + 1}$ , then show that  $\cos \theta \cdot \cos 2\theta \cdot \cos 2^2 \theta \dots \cos 2^{n-1} \theta = \frac{1}{2^n}$ .

$$\begin{aligned} \text{SOLUTION: } &= \cos \theta \cdot \cos 2\theta \dots \cos 2^{n-1} \theta = \frac{1}{2 \sin \theta} (2 \sin \theta \cdot \cos \theta \cos 2\theta \dots \cos 2^{n-1} \theta) \\ &= \frac{1}{2^2 \sin \theta} (2 \sin 2\theta \cdot \cos 2\theta \dots \cos 2^{n-1} \theta) = \frac{1}{2^{n-1} \sin \theta} \sin 2^{n-1} \theta \cdot \cos 2^{n-1} \theta = \frac{1}{2^n \sin \theta} \sin 2^n \theta \\ &= \frac{1}{2^n \sin \theta} \sin(\pi - \theta) = \frac{1}{2^n} \quad [\because \theta = \frac{\pi}{2^n + 1} \therefore 2^n \theta + \theta = \pi] \end{aligned}$$

### TEXTUAL EXERCISE-19 (SUBJECTIVE)

1. Prove that

$$\frac{1}{2^2} \sec^2 \frac{x}{2} + \frac{1}{2^4} \sec^2 \frac{x}{2^2} + \frac{1}{2^6} \sec^2 \frac{x}{2^3} + \dots \infty = \operatorname{cosec}^2 x - \frac{1}{x^2}$$

2. Prove the following:

$$(a) \cos \frac{\pi}{9} \cos \frac{2\pi}{9} \cos \frac{4\pi}{9} = \frac{1}{8}$$

$$(b) \sin \frac{15\pi}{34} \cdot \sin \frac{13\pi}{34} \cdot \sin \frac{9\pi}{34} \cdot \sin \frac{\pi}{34} = \frac{1}{16}$$

$$3. \text{ Prove that } \cos \frac{\pi}{15} \cos \frac{2\pi}{15} \cos \frac{3\pi}{15} \cos \frac{4\pi}{15} \cos \frac{5\pi}{15} \cos \frac{6\pi}{15} \cos \frac{7\pi}{15} = \frac{1}{2^7}$$

$$4. \text{ Prove that } 16 \cos \frac{2\pi}{15} \cos \frac{4\pi}{15} \cos \frac{8\pi}{15} \cos \frac{16\pi}{15} = 1.$$

5. Prove that

$$\left(1 - \tan^2 \frac{\theta}{2}\right) \left(1 - \tan^2 \frac{\theta}{2^2}\right) \left(1 - \tan^2 \frac{\theta}{2^3}\right) \dots \infty = \cot \theta$$

## MULTIPLE CHOICE QUESTIONS

### SECTION-I

#### OBJECTIVE SOLVED EXAMPLES

1. Let  $f(\theta) = \frac{\cot \theta}{1 + \cot \theta}$  and  $\alpha + \beta = \frac{5\pi}{4}$ . Then the value of  $f(\alpha) \cdot f(\beta)$  is  
 (a) 2 (b)  $-1/2$   
 (c)  $1/2$  (d) None of these

**Solution:** (c) Let  $\cot(\alpha + \beta) = \cot \frac{5\pi}{4} = 1$

$$\Rightarrow \frac{\cot \alpha \cot \beta - 1}{\cot \alpha + \cot \beta} = 1$$

$$\Rightarrow \cot \alpha + \cot \beta = \cot \alpha \cdot \cot \beta - 1$$

$$\begin{aligned} \text{Now } f(\alpha) \cdot f(\beta) &= \frac{\cot \alpha \cot \beta}{(1 + \cot \alpha)(1 + \cot \beta)} \\ &= \frac{\cot \alpha \cot \beta}{1 + (\cot \alpha + \cot \beta) + \cot \alpha \cot \beta} \\ &= \frac{\cot \alpha \cot \beta}{2 \cot \alpha \cot \beta} = \frac{1}{2} \end{aligned}$$

2. If  $\sin \alpha + \sin \beta = a$  and  $\cos \alpha - \cos \beta = b$ , then  $\tan \frac{\alpha - \beta}{2}$  is equal to  
 (a)  $-a/b$  (b)  $-b/a$   
 (c)  $\sqrt{a^2 - b^2}$  (d) None of these

**Solution:** (b) Here  $2 \sin \frac{\alpha + \beta}{2} \cos \frac{\alpha - \beta}{2} = a$ ,

$$\text{and } -2 \sin \frac{\alpha + \beta}{2} \sin \frac{\alpha - \beta}{2} = b$$

$$\text{Dividing, we get } \tan \left( \frac{\alpha - \beta}{2} \right) = -\frac{b}{a}$$

3. If  $\frac{2 \sin \alpha}{1 + \sin \alpha + \cos \alpha} = \lambda$ , then  $\frac{1 + \sin \alpha - \cos \alpha}{1 + \sin \alpha}$  is equal to  
 (a)  $1/\lambda$  (b)  $\lambda$   
 (c)  $1 - \lambda$  (d)  $1 + \lambda$

$$\begin{aligned} \text{Solution: (b) } &\frac{1 + \sin \alpha - \cos \alpha}{1 + \sin \alpha} \\ &= \frac{(1 + \sin \alpha)^2 - \cos^2 \alpha}{(1 + \sin \alpha)(1 + \sin \alpha + \cos \alpha)} \\ &= \frac{2 \sin \alpha + 2 \sin^2 \alpha}{(1 + \sin \alpha)(1 + \sin \alpha + \cos \alpha)} = \frac{2 \sin \alpha}{1 + \sin \alpha + \cos \alpha} = \lambda \end{aligned}$$

4. The set of all possible values of  $\alpha$  in  $[-\pi, \pi]$  such that  $\sqrt{\frac{1 - \sin \alpha}{1 + \sin \alpha}} = \sec \alpha - \tan \alpha$  is  
 (a)  $[0, \pi/2]$  (b)  $[0, \pi/2] \cup (\pi/2, \pi)$   
 (c)  $[-\pi, 0]$  (d)  $(-\pi/2, \pi/2)$

**Solution:** (d) Clearly,  $\alpha \neq \pm \pi/2$

$$\Rightarrow \sec \alpha - \tan \alpha = \frac{1 - \sin \alpha}{\cos \alpha} \text{ and}$$

$$\Rightarrow \sqrt{\frac{1 - \sin \alpha}{1 + \sin \alpha}} = \sqrt{\frac{(1 - \sin \alpha)^2}{\cos^2 \alpha}} = \left| \frac{1 - \sin \alpha}{\cos \alpha} \right| = \frac{1 - \sin \alpha}{|\cos \alpha|}$$

Hence, these will be equal if  $\cos \alpha > 0$  i.e.,  $-\pi/2 < \alpha < \pi/2$

5. If  $\tan \alpha = \sqrt{a}$ , where  $a$  is a rational number which is not a perfect square, then which of the following is a rational number?  
 (a)  $\sin 2\alpha$  (b)  $\tan 2\alpha$   
 (c)  $\cos 2\alpha$  (d) None of these

**Solution:** (c) Given  $\tan \alpha = \sqrt{a}$

$$\cos 2\alpha = \frac{1 - \tan^2 \alpha}{1 + \tan^2 \alpha} = \frac{1 - a}{1 + a}$$

$\Rightarrow$  so it is a rational number

$$\sin 2\alpha = \frac{2 \tan \alpha}{1 + \tan^2 \alpha} = \frac{2\sqrt{a}}{1 + a}$$

$\Rightarrow$  it is an irrational number

$$\tan 2\alpha = \frac{2 \tan \alpha}{1 - \tan^2 \alpha} = \frac{2\sqrt{a}}{1 - a}$$

$\Rightarrow$  it is an irrational number



6.  $\operatorname{cosec} \theta = \frac{x^2 - y^2}{x^2 + y^2}$ , where  $x \in \mathbb{R}, y \in \mathbb{R}$  gives real  $\theta$  if and only if  
 (a)  $x = y \neq 0$  (b)  $|x| = |y| \neq 0$   
 (c)  $x + y = 0, x \neq 0$  (d) None of these

**Solution:** (d) Let  $\frac{x^2 - y^2}{x^2 + y^2} \geq 1 \Rightarrow x^2 - y^2 \geq x^2 + y^2$

$$\Rightarrow 2y^2 \leq 0 \quad \Rightarrow y^2 \leq 0 \Rightarrow y = 0$$

$$\Rightarrow \operatorname{cosec} \theta = \frac{x^2}{x^2} = 1; x \neq 0$$

$$\text{or } \frac{x^2 - y^2}{x^2 + y^2} \leq -1 \quad \Rightarrow x^2 - y^2 \leq -x^2 - y^2$$

$$\Rightarrow 2x^2 \leq 0 \quad \Rightarrow x^2 \leq 0 \Rightarrow x = 0$$

$$\Rightarrow \operatorname{cosec} \theta = -\frac{y^2}{y^2} = -1; y \neq 0$$

$\Rightarrow x = 0, y \neq 0$  or  $y = 0, x \neq 0$ . Which do not satisfy any of the given options (a), (b), (c).

7. If  $x = r \sin \theta \cos \phi; y = r \sin \theta \sin \phi$  and  $z = r \cos \theta$  then the value of  $x^2 + y^2 + z^2$  is independent of  
 (a)  $\theta, \phi$  (b)  $r, \theta$   
 (c)  $r, \phi$  (d)  $r$

**Solution:** (a)

$$\text{Let } x^2 + y^2 = r^2 \sin^2 \theta (\cos^2 \phi + \sin^2 \phi) = r^2 \sin^2 \theta$$

$$\text{and } z^2 = r^2 \cos^2 \theta$$

$$\Rightarrow x^2 + y^2 + z^2 = r^2 (\sin^2 \theta + \cos^2 \theta) = r^2$$

Clearly, independent of  $\theta, \phi$ .

8. Let  $n$  be an odd integer. If  $\sin n\theta = \sum_{r=0}^n b_r \sin^r \theta$  for all real  $\theta$ , then  
 (a)  $b_0 = 1, b_1 = 3$   
 (b)  $b_0 = 0, b_1 = n$   
 (c)  $b_0 = -1, b_1 = n$   
 (d)  $b_0 = 0, b_1 = n^2 - 3n - 3$

**Solution:** (b)  $\sin n\theta = b_0 + b_1 \sin \theta + b_2 \sin^2 \theta + \dots + b_n \sin^n \theta$ .

Given,  $n$  is an odd integer

Substituting  $\theta = 0$ , we get  $b_0 = 0$

After differentiating w.r.t.  $\theta$ , and putting  $\theta = 0$ , we get

$$\Rightarrow b_1 = n$$

9. If  $ABC$  is a triangle such that angle  $A$  is obtuse, then  
 (a)  $\tan B \tan C > 1$  (b)  $\tan B \tan C < 1$   
 (c)  $\tan B \tan C = 1$  (d) None of these

**Solution:** (b) Let us take  $\tan A = -\tan(B + C)$

$$\Rightarrow \tan A = \frac{\tan B + \tan C}{\tan B \tan C - 1}$$

Since  $A$  is obtuse therefore  $\tan B \tan C - 1 < 0$

$$\Rightarrow \tan B \tan C < 1$$

10. The minimum value of  $\cos(\cos x)$  is

- (a) 0 (b)  $-\cos 1$   
 (c)  $\cos 1$  (d)  $-1$

**Solution:** (c)  $\cos x$  varies from  $-1$  to  $1$  for all real  $x$

Thus  $\cos(\cos x)$  varies from  $\cos 1$  to  $\cos 0$

$\Rightarrow$  minimum value of  $\cos(\cos x)$  is  $\cos 1$

11. If  $\alpha$  and  $\beta$  are solutions of  $\sin^2 x + a \sin x + b = 0$  as well as that of

$\cos^2 x + c \cos x + d = 0$ , then  $\sin(\alpha + \beta)$  is equal to

- (a)  $\frac{2bd}{b^2 + d^2}$  (b)  $\frac{a^2 + c^2}{2ac}$   
 (c)  $\frac{b^2 + d^2}{2bd}$  (d)  $\frac{2ac}{a^2 + c^2}$

**Solution:** (d) According to the given condition,  $\sin \alpha + \sin \beta = -a$  and  $\cos \alpha + \cos \beta = -c$

$$\Rightarrow 2 \sin \frac{\alpha + \beta}{2} \cos \frac{\alpha - \beta}{2} = -a \text{ and}$$

$$2 \cos \frac{\alpha + \beta}{2} \cos \frac{\alpha - \beta}{2} = -c$$

$$\Rightarrow \tan \frac{\alpha + \beta}{2} = \frac{a}{c}$$

$$\Rightarrow \sin(\alpha + \beta) = \frac{2 \tan \frac{\alpha + \beta}{2}}{1 + \tan^2 \frac{\alpha + \beta}{2}} = \frac{2ac}{a^2 + c^2}$$

12. In a  $\triangle ABC$ , if  $\cot A \cot B \cot C > 0$ , then the triangle is

- (a) acute angled (b) right angled  
 (c) obtuse angled (d) Impossible

**Solution:** (a) Since  $\cot A \cot B \cot C > 0$

$\cot A, \cot B, \cot C$  are positive

$\Rightarrow$  triangle is acute angled

( $\because$  two angles can't be obtuse in a triangle)

13. If  $\sin A, \cos A$  and  $\tan A$  are in G.P., then  $\cot^6 A - \cot^2 A$  equals

- (a)  $\operatorname{cosec}^2 A$  (b)  $\cot^2 A$   
 (c) 1 (d) 0

**Solution:** (c)  $\sin A, \cos A$ , and  $\tan A$  are in G.P.

$$\Rightarrow \cos^2 A = \sin A \tan A \Rightarrow \cos^3 A = \sin^2 A$$

$$\begin{aligned} \Rightarrow \cos^6 A &= \sin^4 A & \Rightarrow \cot^4 A \cos^2 A &= 1 \\ \Rightarrow \cot^4 A &= \sec^2 A = 1 + \frac{1}{\cot^2 A} & \Rightarrow \cot^6 A - \cot^2 A &= 1 \end{aligned}$$

14. The numerical value of  $\sin \frac{\pi}{18} \cdot \sin \frac{5\pi}{18} \cdot \sin \frac{7\pi}{18}$  is equal to

- (a) 1 (b) 1/8  
(c) 1/4 (d) 1/2

**Solution:** (b) Given expression is

$$\begin{aligned} & \sin \frac{\pi}{18} \cdot \sin \frac{5\pi}{18} \cdot \sin \frac{7\pi}{18} \\ &= \cos \frac{8\pi}{18} \cos \frac{4\pi}{18} \cos \frac{2\pi}{18} \\ & \quad \text{(multiply and divide by } 2\sin \frac{2\pi}{18}\text{)} \\ &= \frac{\cos \frac{8\pi}{18} \cos \frac{4\pi}{18} 2\sin \frac{4\pi}{18}}{2^2 \sin \frac{2\pi}{18}} = \frac{2\cos \frac{8\pi}{18} \sin \frac{8\pi}{18}}{2^3 \sin \frac{2\pi}{18}} \\ &= \frac{\sin \frac{16\pi}{18}}{2^3 \sin \frac{2\pi}{18}} = \frac{1}{8} \end{aligned}$$

15. If in a  $\triangle ABC$ ,  $\sin^2 A + \sin^2 B + \sin^2 C = 2$ , then the triangle is always

- (a) isosceles triangle (b) right angled  
(c) acute angled (d) obtuse angled

**Solution:** (b) Given  $\sin^2 A + \sin^2 B + \sin^2 C = 2$

$$\begin{aligned} \Rightarrow 1 - \cos 2A + 1 - \cos 2B + 1 - \cos 2C &= 4 \\ \Rightarrow \cos 2A + \cos 2B + \cos 2C + 1 &= 0 \\ \Rightarrow 2\cos(A+B)\cos(A-B) + 2\cos^2 C &= 0 \\ \Rightarrow \cos(\pi - C)\cos(A-B) + \cos^2 C &= 0 \\ \Rightarrow \cos C(\cos C - \cos(A-B)) &= 0 \\ \Rightarrow \cos C \times [\cos(\pi - (A+B)) - \cos(A-B)] &= 0 \\ \Rightarrow \cos C \times [-\cos(A+B) - \cos(A-B)] &= 0 \\ \Rightarrow \cos C \times [\cos(A+B) + \cos(A-B)] &= 0 \\ \Rightarrow 2\cos A \cos B \cos C &= 0 \\ \Rightarrow \text{either } A = 90^\circ \text{ or } B = 90^\circ \text{ or } C = 90^\circ & \\ \text{Therefore triangle is right angled.} & \end{aligned}$$

16. If in a triangle  $ABC$ ,  $2 \cot B \cot C = 1$ , then  $\cos B \cos C$  will be equal to

- (a)  $\sin A$  (b)  $\sin B$   
(c)  $\cos A$  (d) 1/2

**Solution:** (c) Given  $2 \cot B \cot C = 1$

$$\Rightarrow 2\cos B \cos C = \sin B \sin C$$

$$\begin{aligned} \Rightarrow \cos B \cos C - \sin B \sin C &= -\cos B \cos C \\ \Rightarrow \cos(B+C) &= -\cos B \cos C \\ \Rightarrow \cos B \cos C &= -\cos(B+C) = \cos A \end{aligned}$$

17. If  $S = \cos^2 \frac{\pi}{n} + \cos^2 \frac{2\pi}{n} + \dots + \cos^2 \frac{(n-1)\pi}{n}$ , then the value of  $S$  equals

- (a)  $\frac{n}{2}(n+1)$  (b)  $\frac{1}{2}(n-1)$   
(c)  $\frac{1}{2}(n-2)$  (d)  $\frac{n}{2}$

**Solution:** (c)

Given  $S = \cos^2 \frac{\pi}{n} + \cos^2 \frac{2\pi}{n} + \dots + \cos^2 \frac{(n-1)\pi}{n}$

$$\begin{aligned} &= \frac{1}{2} \left[ 1 + \cos \frac{2\pi}{n} + 1 + \cos \frac{4\pi}{n} + \dots + 1 + \cos \frac{2(n-1)\pi}{n} \right] \\ &= \frac{1}{2} \left[ n-1 + \sum_{k=1}^{n-1} \cos \frac{2k\pi}{n} \right] \end{aligned}$$

Now, we will calculate the value of  $\sum_{k=1}^n \cos \frac{2k\pi}{n}$ .

since we already know that  $\sum_{k=1}^n \cos \frac{2k\pi}{n} = 0$

$$\Rightarrow \sum_{k=1}^{n-1} \cos \frac{2k\pi}{n} + \cos 2\pi = 0$$

$$\Rightarrow \sum_{k=1}^{n-1} \cos \frac{2k\pi}{n} = -1 \Rightarrow S = \frac{1}{2} [n-1-1] = \frac{1}{2}(n-2)$$

18. If  $(\tan x - \tan y)^2$ ,  $(\tan y - \tan z)^2$  and  $(\tan z - \tan x)^2$  are in A.P., then  $(\tan x - \tan y)$ ,  $(\tan y - \tan z)$  and  $(\tan z - \tan x)$  are in

- (a) A.P. (b) G.P.  
(c) H.P. (d) None of these

**Solution:** (c) Let  $a = \tan x - \tan y$ ,  $b = \tan y - \tan z$  and  $c = \tan z - \tan x$

$$\Rightarrow a + b + c = 0 \quad \Rightarrow b^2 = a^2 + c^2 + 2ac$$

$$\text{and } 2b^2 = a^2 + c^2 \quad \Rightarrow 2b^2 = b^2 - 2ac$$

$$\Rightarrow -b^2 = 2ac$$

$$\Rightarrow -b = \frac{2ac}{b} = \frac{2ac}{-(a+c)}$$

$$\Rightarrow b = \frac{2ac}{(a+c)} \quad \therefore a, b, c \text{ are in H.P.}$$

19. If  $|\sin^2 x + 10 - x^2| = |9 - x^2| + 2 \sin^2 x + \cos^2 x$ , then  $x$  lies in

- (a)  $[-8, 8]$  (b)  $[-3, 3]$   
(c)  $[-\sqrt{17}, \sqrt{17}]$  (d) None of these

**Solution:** (b)  $|\sin^2 x + 10 - x^2| = |9 - x^2| + \sin^2 x + 1$

$$|x + y + z| = |x| + |y| + |z|$$

(when all  $x, y, z$  are  $\geq 0$ , or  $\leq 0$ )

$$\Rightarrow 9 - x^2 \geq 0$$

$$\Rightarrow -3 \leq x \leq 3$$

20. The equation  $\cos^8 x + b \cos^4 x + 1 = 0$  will have a solution if  $b$  belongs to

- (a)  $(-\infty, 2]$                       (b)  $[2, \infty)$   
 (c)  $(-\infty, -2]$                       (d) None of these

**Solution:** (c) Given equation can be written as

$$b = -\left(\cos^4 x + \frac{1}{\cos^4 x}\right) \leq -2 \quad \forall x \in \mathbb{R}$$

$$\Rightarrow b \in (-\infty, -2]$$

21. The values of  $p$  for which  $\sqrt{p} \cos x - 2 \sin x = \sqrt{2} + \sqrt{(2-p)}$  has solutions are

- (a)  $p > 0$                               (b)  $p \leq 3$   
 (c)  $0 \leq p \leq 2$                       (d)  $\sqrt{5} - 1 \leq p \leq 2$

**Solution:** (d) The given equation is valid if  $p > 0$  and  $\leq 2$                        $\Rightarrow p \in (0, 2]$  .....(i)

Let  $\sqrt{p} = r \cos \alpha, 2 = r \sin \alpha$

$$\therefore r = \sqrt{(p+4)}$$

$$\therefore \cos(x + \alpha) = \frac{\sqrt{2} + \sqrt{2-p}}{\sqrt{(p+4)}}$$

We must have R.H.S.  $\leq 1$

$$2 + 2 - p + 2\sqrt{2} \sqrt{(2-p)} \leq p + 4$$

$$2\sqrt{2} \sqrt{(2-p)} \leq 2p \quad \therefore 2(2-p) \leq p^2$$

$$\therefore p^2 + 2p - 4 \geq 0 \text{ or } (p - \alpha)(p - \beta) \geq 0$$

where  $\alpha = -1 - \sqrt{5}$  and  $\beta = -1 + \sqrt{5}$

$$\therefore p < -1 - \sqrt{5} \text{ or } p \geq -1 + \sqrt{5} \quad \dots\text{..(ii)}$$

From (i) and (ii) the required limit for  $p$  are as given in (d).

22. If  $\frac{\sec^4 \theta}{a} + \frac{\tan^4 \theta}{b} = \frac{1}{a+b}$ , then

- (a)  $|a| = |b|$                               (b)  $|b| \leq |a|$   
 (c)  $|a| \leq |b|$                               (d) None of these

**Solution:** (b)  $(a \sin^4 \theta + b)(a + b) = abc \cos^4 \theta$

$$\Rightarrow a^2 \sin^4 \theta + ab \sin^4 \theta + ab + b^2 = abc \cos^4 \theta$$

$$\Rightarrow a^2 \sin^4 \theta + ab + b^2 = ab(1 - 2 \sin^2 \theta)$$

$$\Rightarrow a^2 \sin^4 \theta + 2ab \sin^2 \theta + b^2 = 0$$

$$\Rightarrow (a \sin^2 \theta + b)^2 = 0 \quad \Rightarrow \sin^2 \theta = -b/a$$

$$\Rightarrow \left| \frac{b}{a} \right| \leq 1 \quad \Rightarrow |b| \leq |a|.$$

23. If  $\operatorname{cosec}(\theta - \alpha), \operatorname{cosec} \theta, \operatorname{cosec}(\theta + \alpha)$  are in A.P.  $\alpha \in (-\pi/2, \pi/2)$ , then the number of possible values of  $\alpha$  is

- (a) 0    (b) 1  
 (c) 2    (d) None of these

**Solution:** (b)  $2 \operatorname{cosec}(\theta) = \operatorname{cosec}(\theta - \alpha) + \operatorname{cosec}(\theta + \alpha)$

$$\Rightarrow \frac{2}{\sin \theta} = \frac{1}{\sin(\theta - \alpha)} + \frac{1}{\sin(\theta + \alpha)} = \frac{2 \sin \theta \cos \alpha}{\sin^2 \theta - \sin^2 \alpha}$$

$$\Rightarrow \sin^2 \theta \cos \alpha = \sin^2 \theta - \sin^2 \alpha \quad \dots\text{..(i)}$$

$$\Rightarrow \sin^2 \theta = \frac{\sin^2 \alpha}{1 - \cos \alpha} = 2 \cos^2 \alpha / 2 \text{ if } \alpha \neq 0.$$

$$\Rightarrow \sin^2 \theta = 1 + \cos \alpha; \alpha \neq 0$$

$$\Rightarrow 1 + \cos \alpha \in [0, 1]$$

$$\Rightarrow \cos \alpha \in [-1, 0]$$

$$\text{But } \alpha \in \left(-\frac{\pi}{2}, \frac{\pi}{2}\right)$$

$$\Rightarrow \cos \alpha \geq 0$$

$$\Rightarrow \cos \alpha = 0$$

$$\Rightarrow \alpha = \pm \frac{\pi}{2} \notin \left(-\frac{\pi}{2}, \frac{\pi}{2}\right)$$

Now, if  $\alpha = 0$ , for (i), we see that equation holds goods.

$$\therefore \alpha = 0 \text{ is only possible value in } \left(-\frac{\pi}{2}, \frac{\pi}{2}\right)$$

24. If  $\left| \cos \theta \left\{ \sin \theta + \sqrt{\sin^2 \theta + \sin^2 \alpha} \right\} \right| \leq k$ , then the value of  $k$  is

- (a)  $\sqrt{1 + \sin^2 \alpha}$                       (b)  $\sqrt{1 + \cos^2 \alpha}$   
 (c)  $\sqrt{1 + \tan^2 \alpha}$                       (d) None of these

**Solution:** (a) Let  $x = \cos \theta \sin \theta + \cos \theta \sqrt{\sin^2 \theta + \sin^2 \alpha}$  then  $x^2 + \cos^2 \theta \sin^2 \theta - 2x \sin \theta \cos \theta$ .

$$= \cos^2 \theta \sin^2 \theta + \cos^2 \theta \sin^2 \alpha$$

$$\Rightarrow x^2 - 2x \sin \theta \cos \theta - \cos^2 \theta \sin^2 \alpha = 0 \quad \dots\text{.. (i)}$$

If  $\cos \theta = 0; x = 0$ .

If  $\cos \theta \neq 0$ , dividing (i) by  $\cos^2 \theta$ ; we get

$$x^2(1 + \tan^2 \theta) - 2x \tan \theta - \sin^2 \alpha = 0.$$

$$\Rightarrow \tan^2 \theta (x^2) + \tan \theta (-2x) + (x^2 - \sin^2 \alpha) = 0$$

Now this becomes a quadratic in  $\tan \theta$

Since  $\tan \theta$  is real, we have

$$D = 4x^2 - 4x^2 (x^2 - \sin^2 \alpha) \geq 0$$

$$\Rightarrow 4x^2 [1 - x^2 + \sin^2 \alpha] \geq 0$$

$$\Rightarrow x^2 \leq 1 + \sin^2 \alpha \Rightarrow |x| \leq \sqrt{1 + \sin^2 \alpha}$$

$$\therefore k = \sqrt{1 + \sin^2 \alpha}.$$

25. For a non-negative integer  $n$ , let

$$f_n(\theta) = \left(\tan \frac{\theta}{2}\right)(1 + \sec \theta)(1 + \sec 2\theta) \dots (1 + \sec 2^n \theta)$$

(a)  $f_2\left(\frac{\pi}{16}\right) = 1$                       (b)  $f_3\left(\frac{\pi}{32}\right) = 1$

(c)  $f_4\left(\frac{\pi}{64}\right) = 1$                       (d)  $f_5\left(\frac{\pi}{128}\right) = 1$

**Solution:** (a, b, c, d)

$$\begin{aligned} f_0(\theta) &= \left(\tan \frac{\theta}{2}\right)(1 + \sec \theta) = \frac{\sin \theta/2}{\cos \theta/2} \left(1 + \frac{1}{\cos \theta}\right) \\ &= \frac{\sin \theta/2 \cdot 2 \cos^2 \theta/2}{\cos(\theta/2) \cos \theta} = \frac{2 \sin \frac{\theta}{2} \cos \frac{\theta}{2}}{\cos \theta} = \frac{\sin \theta}{\cos \theta} = \tan \theta \end{aligned}$$

Thus  $f_n(\theta) = \left(\tan \frac{\theta}{2}\right)(1 + \sec \theta)(1 + \sec 2\theta)(1 + \sec 4\theta)$   
 $\dots (1 + \sec 2^n \theta)$

$$\begin{aligned} &= (\tan \theta)(1 + \sec \theta)(1 + \sec 4\theta) \dots (1 + \sec 2^n \theta) \\ &= (\tan 2\theta)(1 + \sec 4\theta) \dots (1 + \sec 2^n \theta) \\ &= (\tan 4\theta)(1 + \sec 8\theta) \dots (1 + \sec 2^n \theta) \\ &\quad \vdots \\ &= \tan(2^n \theta) \end{aligned}$$

Now,  $f_2\left(\frac{\pi}{16}\right) = \tan\left(2^2 \frac{\pi}{16}\right) = \tan\left(\frac{\pi}{4}\right) = 1,$

$f_3\left(\frac{\pi}{32}\right) = \tan\left(2^3 \frac{\pi}{32}\right) = \tan\left(\frac{\pi}{4}\right) = 1,$

$f_4\left(\frac{\pi}{64}\right) = \tan\left(2^4 \frac{\pi}{64}\right) = \tan\left(\frac{\pi}{4}\right) = 1$  and

$f_5\left(\frac{\pi}{128}\right) = \tan\left(2^5 \frac{\pi}{128}\right) = \tan\left(\frac{\pi}{4}\right) = 1$

26. If  $\frac{\sin^4 x}{2} + \frac{\cos^4 x}{3} = \frac{1}{5}$ , then:

(a)  $\tan^2 x = \frac{2}{3}$                       (b)  $\frac{\sin^8 x}{8} + \frac{\cos^8 x}{27} = \frac{1}{125}$

(c)  $\tan^2 x = \frac{1}{3}$                       (d)  $\frac{\sin^8 x}{8} + \frac{\cos^8 x}{27} = \frac{2}{125}$

**Solution:** (a, b) If  $\frac{\sin^4 x}{2} + \frac{\cos^4 x}{3} = \frac{1}{5}$ , then

$$\Rightarrow \frac{\sin^4 x}{2} + \frac{(1 - \sin^2 x)^2}{3} = \frac{1}{5}$$

$$\Rightarrow \frac{\sin^4 x}{2} + \frac{1 + \sin^4 x - 2 \sin^2 x}{3} = \frac{1}{5}$$

$$\Rightarrow 25 \sin^4 x - 20 \sin^2 x + 4 = 0$$

$$\Rightarrow (5 \sin^2 x - 2)^2 = 0 \Rightarrow \sin^2 x = \frac{2}{5} \Rightarrow \cos^2 x = \frac{3}{5}$$

$$\Rightarrow \tan^2 x = 2/3 \text{ and } \frac{\sin^8 x}{8} + \frac{\cos^8 x}{27} = \frac{1}{125}$$

27. If in an acute angled  $\Delta ABC$ , if  $\cos A \cos B \cos C \geq k_1$  and  $\sin A + \sin B + \sin C > k_2$ , then find the value of  $k_1 + k_2$

(a)  $\frac{15}{8}$                       (b) 2

(c)  $\frac{17}{8}$                       (d) None of these

**Solution:** (c) Let  $8 \cos A \cos B \cos C = y$ , where  $A, B, C$  are acute angles

$$\Rightarrow 4 [\cos(A + B) + \cos(A - B)] \cos C = y$$

$$\Rightarrow -4 \cos^2 C + 4 \cos C \cos(A - B) = y$$

$$\Rightarrow 4 \cos^2 C - 4 \cos C \cos(A - B) + y = 0$$

$$\Rightarrow \cos C = \frac{4 \cos(A - B) \pm \sqrt{16 \cos^2(A - B) - 16y}}{8}$$

$$\because \cos C \text{ real ; } y \leq \cos^2(A - B)$$

$$\Rightarrow y \leq 1 \Rightarrow \cos A \cos B \cos C \leq 1/8.$$

**Aliter:** GM  $\geq$  HM for positives reals

$$\Rightarrow (\sec A \sec B \sec C)^{1/3} \geq \frac{3}{\cos A + \cos B + \cos C} \geq \frac{3}{3/2} = 2$$

( $\because \cos A \cos B \cos C \leq 3/2$ )

$$\Rightarrow \frac{1}{\cos A \cdot \cos B \cdot \cos C} \geq 8$$

$$\Rightarrow \cos A \cdot \cos B \cdot \cos C \leq 1/8 \Rightarrow k_1 = 1/8$$

Next,  $\because$  for all  $x \in (0, \pi/2)$ ,  $\frac{\sin x}{x}$  is decreasing function

$$\Rightarrow \frac{\sin A}{A} > \frac{\sin \pi/2}{\pi/2} \Rightarrow \sin A > \frac{2A}{\pi}$$

Similarly  $\sin B > \frac{2B}{\pi}$  and  $\sin C > \frac{2C}{\pi}$

$$\Rightarrow \sin A + \sin B + \sin C > 2 \Rightarrow k_2 = 2$$

$$\Rightarrow k_1 + k_2 = 17/8$$

28. If  $A + B + C = \pi$ , then find the minimum value of  $\tan^2 A/2 + \tan^2 B/2 + \tan^2 C/2$

(a) 3                      (b) 1

(c) 2                      (d) None of these

**Solution:** (b) First draw the graph of  $y = \tan^2 x/2$  its period is  $2\pi$ .

Let  $P(A, \tan^2 A/2)$ ,  $Q(B, \tan^2 B/2)$  and  $R(C, \tan^2 C/2)$  be any three points on  $y = \tan^2 x/2$ , then centroid of  $\Delta PQR$  is

$$G\left(\frac{A+B+C}{3}, \frac{\tan^2(A/2) + \tan^2(B/2) + \tan^2(C/2)}{3}\right)$$

Draw  $\perp$  GM on x-axis, meet the curve at L.

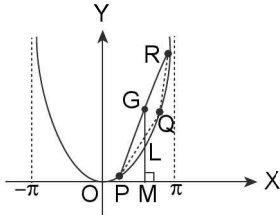

$\therefore$  co-ordinates of L are

$$\left(\frac{A+B+C}{3}, \tan^2\left(\frac{A+B+C}{6}\right)\right)$$

It is clear from the graph of  $y = \tan^2 x/2$  that  $GM \geq ML$

$$\Rightarrow \frac{\tan^2(A/2) + \tan^2(B/2) + \tan^2(C/2)}{3} \geq \tan^2\left(\frac{A+B+C}{6}\right) = \tan^2\left(\frac{\pi}{6}\right) = \left(\frac{1}{\sqrt{3}}\right)^2 = \frac{1}{3}$$

Hence  $\tan^2 A/2 + \tan^2 B/2 + \tan^2 C/2 \geq 1$

29. The sum of the series  $\cos^3 \alpha + \cos^3 2\alpha + \cos^3 3\alpha + \dots$  to  $n$  terms is

$$(a) \quad 3 \frac{\cos\left(\frac{n+1}{2}\right)\alpha \sin\left(\frac{n\alpha}{2}\right)}{\sin\frac{\alpha}{2}} + \frac{\cos\frac{3(n+1)}{2}\alpha \sin\frac{3n\alpha}{2}}{\sin\frac{3\alpha}{2}}$$

$$(b) \quad 3 \frac{\sin\left(\frac{n+1}{2}\right)\alpha \cos\left(\frac{n\alpha}{2}\right)}{\cos\frac{\alpha}{2}} + \frac{\sin\frac{3(n+1)}{2}\alpha \cos\frac{3n\alpha}{2}}{\cos\frac{3\alpha}{2}}$$

$$(c) \quad 3 \frac{\sin\left(\frac{n+1}{2}\right)\alpha \cos\left(\frac{n\alpha}{2}\right)}{\cos\frac{\alpha}{2}} - \frac{\sin\frac{3(n+1)}{2}\alpha \cos\frac{3n\alpha}{2}}{\cos\frac{3\alpha}{2}}$$

(d) None of these

**Solution:** (a) We have  $\cos 3\alpha = 4\cos^3 \alpha - 3\cos \alpha$  so that  $4\cos^3 \alpha = 3\cos \alpha + \cos 3\alpha$   
 $\Rightarrow 4\cos^3 2\alpha = 3\cos 2\alpha + \cos 6\alpha$ ,  
 and  $4\cos^3 3\alpha = 3\cos 3\alpha + \cos 9\alpha$

Hence if  $S$  be the given series, we have

$$4S = (3\cos \alpha + \cos 3\alpha) + (3\cos 2\alpha + \cos 6\alpha) + (3\cos 3\alpha + \cos 9\alpha) + \dots$$

$$= 3(\cos \alpha + \cos 2\alpha + \cos 3\alpha + \dots) + (\cos 3\alpha + \cos 6\alpha + \cos 9\alpha + \dots)$$

$$= 3 \frac{\cos\left\{\alpha + \frac{n-1}{2}\alpha\right\} \sin\frac{n\alpha}{2}}{\sin\frac{\alpha}{2}} +$$

$$\frac{\cos\left\{3\alpha + \frac{n-1}{2}\cdot 3\alpha\right\} \sin\frac{n\cdot 3\alpha}{2}}{\sin\frac{3\alpha}{2}}$$

$$= 3 \frac{\cos\left(\frac{n+1}{2}\right)\alpha \sin\left(\frac{n\alpha}{2}\right)}{\sin\frac{\alpha}{2}} + \frac{\cos\frac{3(n+1)}{2}\alpha \sin\frac{3n\alpha}{2}}{\sin\frac{3\alpha}{2}}$$

Remarks:

- In a similar manner, we can obtain the sum of the cubes of the sines of a series of angles in A.P.
- We can similarly obtain the sum of the squares since  $2\sin^2 \alpha = 1 - \cos 2\alpha$  and  $2\cos^2 \alpha = 1 + \cos 2\alpha$
- Again since  $8\sin^4 \alpha = 2[1 - \cos 2\alpha]^2 = 2 - 4\cos 2\alpha + 2\cos^2 2\alpha = 3 - 4\cos 2\alpha + \cos 4\alpha$  we can obtain the sum of the 4th powers of the sines. Similarly, for the cosines.

## SECTION-II

### SUBJECTIVE SOLVED QUESTIONS

1. If  $\alpha, \beta$  and  $\gamma$  are in A.P., show that  $\cot \beta = \frac{\sin \alpha - \sin \gamma}{\cos \gamma - \cos \alpha}$ .

**Solution:** Since  $\alpha, \beta$  and  $\gamma$  are in A.P.,  $2\beta = \alpha + \gamma$

$$\Rightarrow \cot \beta = \cot \frac{\alpha + \gamma}{2} = \frac{\cos\frac{\alpha + \gamma}{2}}{\sin\frac{\alpha + \gamma}{2}}$$

$$= \frac{2 \cos \frac{\alpha + \gamma}{2} \sin \frac{\alpha - \gamma}{2}}{2 \sin \frac{\alpha + \gamma}{2} \sin \frac{\alpha - \gamma}{2}} = \frac{\sin \alpha - \sin \gamma}{\cos \gamma - \cos \alpha}$$

2. Find  $x$  from the equation  $\operatorname{cosec}(90^\circ + A) + x \cos A$   
 $\cot(90^\circ + A) = \sin(90^\circ + A)$ .

**Solution:**

$$\operatorname{cosec}(90^\circ + A) = \sec A; \cot(90^\circ + A) = -\tan A$$

$$; \sin(90^\circ + A) = \cos A$$

$$\therefore \text{L.H.S.} = \sec A + x \cos A (-\tan A) = \frac{1}{\cos A} - x \sin A$$

$$\text{Now we have } \frac{1}{\cos A} - x \sin A = \cos A = \text{R.H.S.}$$

$$\Rightarrow \frac{1}{\cos A} - \cos A = x \sin A$$

$$\Rightarrow \frac{1 - \cos^2 A}{\cos A} = x \sin A \Rightarrow \frac{\sin^2 A}{\sin A \cos A} = x$$

$$\Rightarrow x = \tan A$$

3. Show that  $\cos \frac{2\pi}{7} + \cos \frac{4\pi}{7} + \cos \frac{6\pi}{7} = -\frac{1}{2}$ .

**Solution:**

$$\text{L.H.S.} = \frac{2 \sin \frac{\pi}{7} \left( \cos \frac{2\pi}{7} + \cos \frac{4\pi}{7} + \cos \frac{6\pi}{7} \right)}{2 \sin \frac{\pi}{7}}$$

$$= \frac{1}{2 \sin \frac{\pi}{7}} \left[ \left( \sin \frac{3\pi}{7} - \sin \frac{\pi}{7} \right) + \left( \sin \frac{5\pi}{7} - \sin \frac{3\pi}{7} \right) + \left( \sin \frac{7\pi}{7} - \sin \frac{5\pi}{7} \right) \right]$$

$$= \frac{\sin \pi - \sin \frac{\pi}{7}}{2 \sin \frac{\pi}{7}} = -\frac{1}{2}$$

4. Show that  $\sin 12^\circ \cdot \sin 48^\circ \cdot \sin 54^\circ = 1/8$ .

$$\text{Solution: L.H.S.} = \frac{1}{2} [\cos 36^\circ - \cos 60^\circ] \sin 54^\circ$$

$$= \frac{1}{2} [\cos 36^\circ \sin 54^\circ - \frac{1}{2} \sin 54^\circ]$$

$$= \frac{1}{4} [2 \cos 36^\circ \sin 54^\circ - \sin 54^\circ]$$

$$= \frac{1}{4} [\sin 90^\circ + \sin 18^\circ - \sin 54^\circ]$$

$$= \frac{1}{4} [1 - (\sin 54^\circ - \sin 18^\circ)] = \frac{1}{4} [1 - 2 \sin 18^\circ \cos 36^\circ]$$

$$= \frac{1}{4} \left[ 1 - \frac{2 \sin 18^\circ}{\cos 18^\circ} \cos 18^\circ \cos 36^\circ \right]$$

$$= \frac{1}{4} \left[ 1 - \frac{\sin 36^\circ \cos 36^\circ}{\cos 18^\circ} \right]$$

$$= \frac{1}{4} \left[ 1 - \frac{2 \sin 36^\circ \cos 36^\circ}{2 \cos 18^\circ} \right] = \frac{1}{4} \left[ 1 - \frac{\sin 72^\circ}{2 \sin 72^\circ} \right]$$

$$= \frac{1}{4} [1 - 1/2] = 1/8 = \text{R.H.S.}$$

5. If  $\theta$  is not an odd multiple of  $\pi/2$ , then prove that

$$\tan 9\theta = \frac{9 \tan \theta - 84 \tan^3 \theta + 126 \tan^5 \theta - 36 \tan^7 \theta + \tan^9 \theta}{1 - 36 \tan^2 \theta + 126 \tan^4 \theta - 84 \tan^6 \theta + 9 \tan^8 \theta}$$

$$\text{Solution: } \cos 9\theta + i \sin 9\theta = (\cos \theta + i \sin \theta)^9 = \cos^9 \theta$$

$$(1 + i \tan \theta)^9 = \cos^9 \theta (1 - {}^9C_2 \tan^2 \theta + {}^9C_4 \tan^4 \theta - {}^9C_6 \tan^6 \theta + {}^9C_8 \tan^8 \theta) + i \cos^9 \theta ({}^9C_1 \tan \theta - {}^9C_3 \tan^3 \theta + {}^9C_5 \tan^5 \theta - {}^9C_7 \tan^7 \theta + {}^9C_9 \tan^9 \theta)$$

Equating real and imaginary parts and dividing imaginary part by real part, we get

$$\tan 9\theta = \frac{9 \tan \theta - 84 \tan^3 \theta + 126 \tan^5 \theta - 36 \tan^7 \theta + \tan^9 \theta}{1 - 36 \tan^2 \theta + 126 \tan^4 \theta - 84 \tan^6 \theta + 9 \tan^8 \theta}$$

6. If  $x + y + z = xyz$ , prove that

$$\frac{x}{1-x^2} + \frac{y}{1-y^2} + \frac{z}{1-z^2} = \frac{xyz}{(1-x^2)(1-y^2)(1-z^2)}$$

$$\text{Solution: Let } x = \tan A, y = \tan B, z = \tan C$$

$$\therefore \tan A + \tan B + \tan C = \tan A \tan B \tan C$$

$$\Rightarrow -\tan C = \frac{\tan A + \tan B}{1 - \tan A \tan B}$$

$$\Rightarrow \tan(A + B) = \tan(n\pi - C)$$

$$\Rightarrow A + B + C = n\pi; n \in \mathbb{Z}$$

$$\therefore \tan(2A + 2B) = \tan(2n\pi - 2C)$$

$$\Rightarrow \tan 2A + \tan 2B + \tan 2C = \tan 2A \tan 2B \tan 2C$$

$$\Rightarrow \frac{2x}{1-x^2} + \frac{2y}{1-y^2} + \frac{2z}{1-z^2} = \frac{8xyz}{(1-x^2)(1-y^2)(1-z^2)}$$

$$\left[ \because \tan 2A = \frac{2 \tan A}{1 - \tan^2 A} \right]$$

$$\Rightarrow \frac{x}{1-x^2} + \frac{y}{1-y^2} + \frac{z}{1-z^2} = \frac{4xyz}{(1-x^2)(1-y^2)(1-z^2)}$$

7. Prove that

$$\left( 1 + \cos \frac{\pi}{8} \right) \left( 1 + \cos \frac{3\pi}{8} \right) \left( 1 + \cos \frac{5\pi}{8} \right) \left( 1 + \cos \frac{7\pi}{8} \right) = \frac{1}{8}$$

**Solution:** Writing  $\cos \frac{5\pi}{8} = \cos \left( \frac{\pi}{2} + \frac{\pi}{8} \right) = -\sin \frac{\pi}{8}$

$$\Rightarrow \cos \frac{3\pi}{8} = \cos \left( \frac{\pi}{2} - \frac{\pi}{8} \right) = \sin \frac{\pi}{8}$$

$$\Rightarrow \cos \frac{7\pi}{8} = \cos \left( \pi - \frac{\pi}{8} \right) = -\cos \frac{\pi}{8}$$

$$\begin{aligned} \text{L.H.S.} &= \left( 1 + \cos \frac{\pi}{8} \right) \left( 1 - \cos \frac{\pi}{8} \right) \left( 1 + \sin \frac{\pi}{8} \right) \left( 1 - \sin \frac{\pi}{8} \right) \\ &= \left( 1 - \cos^2 \frac{\pi}{8} \right) \left( 1 - \sin^2 \frac{\pi}{8} \right) = \sin^2 \frac{\pi}{8} \cos^2 \frac{\pi}{8} \\ &= \frac{1}{4} \left( \sin \frac{\pi}{4} \right)^2 = \frac{1}{4} \cdot \frac{1}{2} = \frac{1}{8} = \text{R.H.S.} \end{aligned}$$

8. If  $\sin x + \sin y = a$  and  $\cos x + \cos y = b$ , show that

$$\sin(x+y) = \frac{2ab}{a^2+b^2} \text{ and } \tan \frac{x-y}{2} = \pm \sqrt{\frac{4-a^2-b^2}{a^2+b^2}}$$

**Solution:** Let  $\sin x + \sin y = a$  (given)

$$\Rightarrow 2 \sin \frac{x+y}{2} \cdot \cos \frac{x-y}{2} = a \quad \dots(i)$$

$$\cos x + \cos y = b$$

$$\Rightarrow 2 \cos \frac{x+y}{2} \cdot \cos \frac{x-y}{2} = b \quad \dots(ii)$$

Dividing (i) by (ii), we get  $\tan \frac{x+y}{2} = \frac{a}{b}$

$$\therefore \sin(x+y) = \frac{2 \tan \frac{x+y}{2}}{1 + \tan^2 \frac{x+y}{2}} = \frac{2 \cdot \frac{a}{b}}{1 + \frac{a^2}{b^2}}$$

Squaring (i) and (ii), then adding we get

$$4 \cos^2 \frac{x-y}{2} \left\{ \sin^2 \frac{x+y}{2} + \cos^2 \frac{x+y}{2} \right\} = a^2 + b^2$$

$$\Rightarrow 4 \cos^2 \frac{x-y}{2} = a^2 + b^2 \Rightarrow \cos^2 \frac{x-y}{2} = \frac{a^2 + b^2}{4}$$

$$\Rightarrow \sin^2 \frac{x-y}{2} = 1 - \frac{a^2 + b^2}{4} = \frac{4 - a^2 - b^2}{4}$$

$$\begin{aligned} \Rightarrow \tan^2 \frac{x-y}{2} &= \frac{\sin^2 \frac{x-y}{2}}{\cos^2 \frac{x-y}{2}} \\ &= \frac{4 - a^2 - b^2}{4} \times \frac{4}{a^2 + b^2} = \frac{4 - a^2 - b^2}{a^2 + b^2} \end{aligned}$$

$$\Rightarrow \tan \frac{x-y}{2} = \pm \sqrt{\frac{4 - a^2 - b^2}{a^2 + b^2}}$$

9. If  $\tan \beta = \frac{n \sin \alpha \cos \alpha}{1 - n \sin^2 \alpha}$ . Prove that  $\tan(\alpha - \beta) =$

$$(l - m) \tan \alpha.$$

$$\begin{aligned} \text{Solution: Given } \tan \beta &= \frac{n \sin \alpha \cos \alpha}{1 - n \sin^2 \alpha} \\ &= \frac{n \tan \alpha}{\sec^2 \alpha - n \tan^2 \alpha} \end{aligned}$$

$$= \frac{n \tan \alpha}{1 + \tan^2 \alpha - n \tan^2 \alpha} = \frac{n \tan \alpha}{1 + (1 - n) \tan^2 \alpha}$$

$$\text{Now LHS} = \tan(\alpha - \beta) = \frac{\tan \alpha - \tan \beta}{1 + \tan \alpha \tan \beta}$$

$$= \frac{\tan \alpha - \frac{n \tan \alpha}{1 + (1 - n) \tan^2 \alpha}}{1 + \tan \alpha \frac{n \tan \alpha}{1 + (1 - n) \tan^2 \alpha}}$$

$$= \frac{\tan \alpha + (1 - n) \tan^3 \alpha - n \tan \alpha}{1 + (1 - n) \tan^2 \alpha + n \tan^2 \alpha} = (1 - n) \tan \alpha$$

10. Prove that  $\sin A \sin(B - C) + \sin B \sin(C - A) + \sin C \sin(A - B) = 0$ .

**Solution:** The LHS can be written as  $\sum \sin A \sin(B - C)$

$$= \sum \frac{1}{2} [2 \sin A \sin(B - C)]$$

$$= \sum \frac{1}{2} [\cos(A - B + C) - \cos(A + B - C)]$$

$$= \frac{1}{2} \sum [\cos(A - B + C) - \cos(A + B - C)]$$

$$= \frac{1}{2} [\{\cos(A - B + C) - \cos(A + B - C) +$$

$$\{\cos(B - C + A) - \cos(B + C - A)\}$$

$$+ \{\cos(C - A + B) - \cos(C + A - B)\}] = 0$$

**Aliter:** LHS =  $\sum \sin A \sin(B - C)$

$$= \sum \sin(\pi - (B + C)) \sin(B - C)$$

$$\because A + B + C = \pi \Rightarrow [\pi - (B + C)] = A$$

$$= \sum \sin(B + C) \sin(B - C)$$

$$= \sum \sin^2 B - \sin^2 C$$

$$= \sin^2 B - \sin^2 C + \sin^2 C - \sin^2 A + \sin^2 A - \sin^2 B = 0$$

11. If  $A, B$  and  $C$  are the angles of a triangle, show that

$$\tan^2 \frac{A}{2} + \tan^2 \frac{B}{2} + \tan^2 \frac{C}{2} \geq 1$$

**Solution:** Since we know that  $\frac{A}{2} + \frac{B}{2} + \frac{C}{2} = \frac{\pi}{2}$

$$\Rightarrow \tan\left(\frac{A}{2} + \frac{B}{2}\right) = \tan\left(\frac{\pi}{2} - \frac{C}{2}\right)$$

$$\Rightarrow \frac{\tan \frac{A}{2} + \tan \frac{B}{2}}{1 - \tan \frac{A}{2} \tan \frac{B}{2}} = \frac{1}{\tan \frac{C}{2}}$$

$$\Rightarrow \tan \frac{A}{2} \tan \frac{B}{2} + \tan \frac{B}{2} \tan \frac{C}{2} + \tan \frac{C}{2} \tan \frac{A}{2} = 1$$

we know that  $\left(\tan \frac{A}{2} - \tan \frac{B}{2}\right)^2 + \left(\tan \frac{B}{2} - \tan \frac{C}{2}\right)^2 + \left(\tan \frac{C}{2} - \tan \frac{A}{2}\right)^2 \geq 0$

$$\Rightarrow 2\left(\tan^2 \frac{A}{2} + \tan^2 \frac{B}{2} + \tan^2 \frac{C}{2}\right) - 2\left(\tan \frac{A}{2} \tan \frac{B}{2} + \tan \frac{B}{2} \tan \frac{C}{2} + \tan \frac{C}{2} \tan \frac{A}{2}\right) \geq 0$$

$$\Rightarrow \tan^2 \frac{A}{2} + \tan^2 \frac{B}{2} + \tan^2 \frac{C}{2} \geq 1$$

12. If  $A + B + C = \pi$  then show that  $\cot A + \cot B + \cot C - \operatorname{cosec} A \cdot \operatorname{cosec} B \cdot \operatorname{cosec} C = \cot A \cdot \cot B \cdot \cot C$

**Solution:** LHS =  $\frac{\cos A}{\sin A} + \frac{\cos B}{\sin B} + \frac{\cos C}{\sin C} - \frac{1}{\sin A \sin B \sin C}$

$$= \frac{\cos A \sin B \sin C + \cos B \sin C \sin A + \cos C \sin A \sin B - 1}{\sin A \sin B \sin C}$$

$$= \frac{\sin C (\cos A \sin B + \cos B \sin A) + \cos C \sin A \sin B - 1}{\sin A \sin B \sin C}$$

$$= \frac{\sin C \sin(A+B) + \cos C \sin A \sin B - 1}{\sin A \sin B \sin C}$$

$$= \frac{\sin^2 C + \cos C \sin A \sin B - 1}{\sin A \sin B \sin C}$$

$$[\because \sin(A+B) = \sin(\pi - C) = \sin C]$$

$$= \frac{\cos C \cdot \sin A \sin B - \cos^2 C}{\sin A \sin B \sin C}$$

$$= \frac{\cos C \{\sin A \sin B - \cos(\pi - A + B)\}}{\sin A \sin B \sin C}$$

$$= \frac{\cos C \cdot \{\sin A \sin B + \cos(A+B)\}}{\sin A \sin B \sin C}$$

$$= \frac{\cos C \cdot \cos A \cos B}{\sin A \sin B \sin C}$$

$$= \cot A \cot B \cdot \cot C$$

13. If  $A + B + C = \pi$ , prove that  $\frac{\sin 2A + \sin 2B + \sin 2C}{\cos A + \cos B + \cos C} = 1$   
 $= 8 \cos \frac{A}{2} \cos \frac{B}{2} \cos \frac{C}{2}$

**Solution:** L.H.S. =  $\frac{2 \sin(A+B) \cos(A-B) + 2 \sin C \cos C}{2 \cos \frac{A+B}{2} \cdot \cos \frac{A-B}{2} - 2 \sin^2 \frac{C}{2}}$

$$= \frac{\sin C \cos(A-B) - \sin C \cos(A+B)}{\sin \frac{C}{2} \cos \frac{A-B}{2} - \sin \frac{C}{2} \cos \frac{A+B}{2}}$$

$$= \frac{2 \sin \frac{C}{2} \cos \frac{C}{2} [\cos(A-B) - \cos(A+B)]}{\sin \frac{C}{2} \left( \cos \frac{A-B}{2} - \cos \frac{A+B}{2} \right)}$$

$$= 2 \cos \frac{C}{2} \cdot \frac{2 \sin A \sin B}{2 \sin \frac{A}{2} \sin \frac{B}{2}}$$

$$= 8 \cos \frac{A}{2} \cos \frac{B}{2} \cos \frac{C}{2} = \text{R.H.S.}$$

14. Prove that  $\sum_{r=1}^5 \cos(2r-1) \frac{\pi}{11} = \frac{1}{2}$ .

**Solution:**  $\sum_{r=1}^5 \cos(2r-1) \frac{\pi}{11}$

$$= \cos \frac{\pi}{11} + \cos \frac{3\pi}{11} + \cos \frac{5\pi}{11} + \cos \frac{7\pi}{11} + \cos \frac{9\pi}{11}$$

$$= \frac{2 \sin \frac{\pi}{11}}{2 \sin \frac{\pi}{11}} \left( \cos \frac{\pi}{11} + \cos \frac{3\pi}{11} + \cos \frac{5\pi}{11} + \cos \frac{7\pi}{11} + \cos \frac{9\pi}{11} \right)$$

$$= \frac{\left( \sin \frac{2\pi}{11} + \sin \frac{4\pi}{11} - \sin \frac{2\pi}{11} + \sin \frac{6\pi}{11} - \sin \frac{4\pi}{11} + \sin \frac{8\pi}{11} - \sin \frac{6\pi}{11} + \sin \frac{10\pi}{11} - \sin \frac{8\pi}{11} \right)}{2 \sin \frac{\pi}{11}}$$

$$= \frac{\sin \frac{10\pi}{11}}{2 \sin \frac{\pi}{11}} = \frac{\sin \left( \pi - \frac{\pi}{11} \right)}{2 \sin \frac{\pi}{11}} = \frac{1}{2}$$



1.72 > Trigonometry

15. In an acute angled  $\triangle ABC$ , prove that  $\tan A + \tan B + \tan C \geq 3\sqrt{3}$ .

**Solution:** Let  $\tan(A + B) = \tan(180^\circ - C)$

$$\Rightarrow \frac{\tan A + \tan B}{1 - \tan A \tan B} = -\tan C$$

$$\Rightarrow \tan A + \tan B + \tan C = \tan A \tan B \tan C$$

$$\text{Now } \frac{\tan A + \tan B + \tan C}{3} \geq \sqrt[3]{\tan A \tan B \tan C}$$

[ $\because A, B, C < \pi/2 \Rightarrow \tan A, \tan B, \tan C > 0$  and A.M  $\geq$  G.M]

$$\Rightarrow \frac{\tan A \tan B \tan C}{3} \geq \sqrt[3]{\tan A \tan B \tan C}$$

$$\Rightarrow \tan^2 A \tan^2 B \tan^2 C \geq 27$$

$$\Rightarrow (\tan A + \tan B + \tan C)^2 \geq 27$$

$$\Rightarrow \tan A + \tan B + \tan C \geq 3\sqrt{3}$$

and the equality holds when  $A = B = C = \pi/3$

16. If  $\alpha$  and  $\beta$  be two different roots of the equation  $a \cos \theta + b \sin \theta = c$ , then prove that  $\cos(\alpha + \beta) = \frac{a^2 - b^2}{a^2 + b^2}$ .

**Solution:** Here  $a \cdot \frac{1 - \tan^2 \theta/2}{1 + \tan^2 \theta/2} + b \cdot \frac{2 \tan \theta/2}{1 + \tan^2 \theta/2} = c$

$$\Rightarrow a \left(1 - \tan^2 \frac{\theta}{2}\right) + 2b \tan \frac{\theta}{2} = c \left(1 + \tan^2 \frac{\theta}{2}\right)$$

$$\Rightarrow (a+c) \tan^2 \frac{\theta}{2} - 2b \tan \frac{\theta}{2} + (c-a) = 0$$

Roots of the equation are  $\tan \frac{\alpha}{2}$  and  $\tan \frac{\beta}{2}$

$$\Rightarrow \tan \frac{\alpha}{2} + \tan \frac{\beta}{2} = \frac{2b}{a+c} \text{ and } \tan \frac{\alpha}{2} \tan \frac{\beta}{2} = \frac{c-a}{a+c}$$

$$\Rightarrow \tan \frac{\alpha + \beta}{2} = \frac{\tan \alpha/2 + \tan \beta/2}{1 - \tan \alpha/2 \tan \beta/2} = \frac{\frac{2b}{a+c}}{1 - \frac{c-a}{c+a}} = \frac{b}{a}$$

$$\Rightarrow \cos(\alpha + \beta) = \frac{1 - \tan^2 \frac{\alpha + \beta}{2}}{1 + \tan^2 \frac{\alpha + \beta}{2}} = \frac{1 - \frac{b^2}{a^2}}{1 + \frac{b^2}{a^2}} = \frac{a^2 - b^2}{a^2 + b^2}$$

17. Prove that

$$\begin{aligned} & \frac{\sin \theta}{\cos \theta} + \frac{\sin 2\theta}{\cos^2 \theta} + \frac{\sin 3\theta}{\cos^3 \theta} + \dots + \frac{\sin n\theta}{\cos^n \theta} \\ &= \cot \theta - \frac{\cos(n+1)\theta}{\sin \theta \cos^n \theta} \end{aligned}$$

**Solution:** Let

$$\cot \theta - \frac{\sin \theta}{\cos \theta} = \frac{\cos^2 \theta - \sin^2 \theta}{\cos \theta \sin \theta} = \frac{\cos 2\theta}{\cos \theta \sin \theta} \quad \dots(i)$$

$$\begin{aligned} & \frac{\cos 2\theta}{\cos \theta \sin \theta} - \frac{\sin 2\theta}{\cos^2 \theta} \\ &= \frac{1}{\cos \theta} \left( \frac{\cos 2\theta \cos \theta - \sin 2\theta \sin \theta}{\sin \theta \cos \theta} \right) \end{aligned}$$

$$\therefore \frac{\cos 2\theta}{\cos \theta \sin \theta} - \frac{\sin 2\theta}{\cos^2 \theta} = \frac{1}{\cos^2 \theta} \frac{\cos 3\theta}{\sin \theta} \quad \dots(ii)$$

$$\text{Similarly, } \frac{\cos 3\theta}{\cos^2 \theta \sin \theta} - \frac{\sin 3\theta}{\cos^3 \theta} = \frac{1}{\cos^3 \theta} \frac{\cos 4\theta}{\sin \theta} \quad \dots(iii)$$

$$\begin{aligned} & \dots \dots \dots \dots \dots \dots \\ & \dots \dots \dots \dots \dots \dots \\ & \frac{\cos n\theta}{\cos^{n-1} \theta \sin \theta} - \frac{\sin n\theta}{\cos^n \theta} = \frac{1}{\cos^n \theta} \frac{\cos(n+1)\theta}{\sin \theta} \end{aligned}$$

Adding (i), (ii), (iii),.....(n), we get

$$\begin{aligned} \cot \theta - \left[ \frac{\sin \theta}{\cos \theta} + \frac{\sin 2\theta}{\cos^2 \theta} + \frac{\sin 3\theta}{\cos^3 \theta} + \dots + \frac{\sin n\theta}{\cos^n \theta} \right] \\ = \frac{1}{\cos^n \theta} \frac{\cos(n+1)\theta}{\sin \theta} \end{aligned}$$

18. If  $\frac{\cos^4 x}{\cos^2 y} + \frac{\sin^4 x}{\sin^2 y} = 1$  prove that  $\frac{\cos^4 y}{\cos^2 x} + \frac{\sin^4 y}{\sin^2 x} = 1$ .

**Solution:** Consider  $\frac{\cos^4 x}{\cos^2 y} + \frac{\sin^4 x}{\sin^2 y} = 1$

$$\Rightarrow \left[ \frac{\cos^4 x}{\cos^2 y} - \cos^2 x \right] + \left[ \frac{\sin^4 x}{\sin^2 y} - \sin^2 x \right] = 0$$

$$\Rightarrow \frac{\cos^2 x}{\cos^2 y} (\cos^2 x - \cos^2 y) - \frac{\sin^2 x}{\sin^2 y} (\cos^2 x - \cos^2 y) = 0$$

$$\Rightarrow (\cos^2 x - \cos^2 y) \left[ \frac{\cos^2 x}{\cos^2 y} - \frac{\sin^2 x}{\sin^2 y} \right] = 0$$

$$\Rightarrow \cos^2 x = \cos^2 y \text{ or } \tan^2 x = \tan^2 y \quad \dots(i)$$

Now, the LHS of the identity to be proved

$$\begin{aligned} &= \frac{\cos^4 y}{\cos^2 x} + \frac{\sin^4 y}{\sin^2 x} = \frac{\cos^4 x}{\cos^2 x} + \frac{\sin^4 x}{\sin^2 x} \quad [\text{Using (i)}] \\ &= \cos^2 x + \sin^2 x = 1 = \text{RHS} \end{aligned}$$

19. Find the sum of the series  $\sin \theta + \sin 3\theta + \sin 5\theta + \dots$  upto infinity.

**Solution:** Let  $C = \cos \theta + \cos 3\theta + \cos 5\theta + \dots$   
 $S = \sin \theta + \sin 3\theta + \sin 5\theta + \dots$

$$\begin{aligned} \text{So, } C + iS &= (\cos\theta + i\sin\theta) + (\cos3\theta + i\sin3\theta) + \dots \\ &= e^{i\theta} + e^{i3\theta} + e^{i5\theta} + \dots = \frac{e^{i\theta}}{1 - e^{i2\theta}} = \frac{\cos\theta + i\sin\theta}{(1 - \cos 2\theta) - i\sin 2\theta} \\ &= \frac{\cos\theta + i\sin\theta}{(1 - \cos 2\theta) - i\sin 2\theta} \times \frac{(1 - \cos 2\theta) + i\sin 2\theta}{(1 - \cos 2\theta) + i\sin 2\theta} \\ \Rightarrow I_m(C + iS) &= \frac{(1 - \cos 2\theta)\sin\theta + \cos\theta\sin 2\theta}{(1 - \cos 2\theta)^2 + \sin^2 2\theta} \\ &= \frac{\sin 2\theta\cos\theta - \cos 2\theta.\sin\theta + \sin\theta}{2 - 2\cos 2\theta} \\ &= \frac{\sin\theta}{1 - \cos 2\theta} = \frac{\sin\theta}{2\sin^2\theta} = \frac{1}{2}\operatorname{cosec}\theta \end{aligned}$$

20. For all  $\theta$  in  $[0, \pi/2]$ , show that  $\cos(\sin\theta) - \sin(\cos\theta) > 0$ .

**Solution:** We have,  $\cos\theta + \sin\theta$

$$\begin{aligned} &= \sqrt{2} \left[ \frac{1}{\sqrt{2}}\cos\theta + \frac{1}{\sqrt{2}}\sin\theta \right] \\ &= \sqrt{2} \left[ \left( \sin \frac{\pi}{4} \right) \cos\theta + \left( \cos \frac{\pi}{4} \right) \sin\theta \right] \\ &= \sqrt{2} \sin \left( \frac{\pi}{4} + \theta \right) \end{aligned}$$

$$\Rightarrow \cos\theta + \sin\theta \leq \sqrt{2} < \pi/2 \quad [\text{as } \sqrt{2} = 1.414]$$

$$\Rightarrow \cos\theta + \sin\theta < \pi/2 \quad [\pi/2 = 1.57 \text{ approx.}]$$

$$\Rightarrow \cos\theta < \pi/2 - \sin\theta; \theta \in [0, \pi/2];$$

$$\frac{\pi}{2} - \sin\theta \in \left[ \frac{\pi}{2} - 1, \frac{\pi}{2} \right]$$

Taking sine on both sides; ( $\because \sin\theta$  increasing in

$$\left[ 0, \frac{\pi}{2} \right])$$

$$\Rightarrow \sin(\cos\theta) < \sin \left( \frac{\pi}{2} - \sin\theta \right)$$

$$\Rightarrow \sin(\cos\theta) < \cos(\sin\theta) \quad \therefore \cos(\sin\theta) > \sin(\cos\theta)$$

21. Find all possible real values of  $\theta$  and  $\phi$  satisfying:

$$\sin^2\theta + 4\sin^2\phi - \sin\theta - 2\sin\phi - 2\sin\theta.\sin\phi + 1 = 0, \text{ for all } \theta, \phi \in [0, \pi/2].$$

**Solution:** Given equation can be rewritten as,

$$\sin^2\theta - \sin\theta(1 + 2\sin\phi) + (4\sin^2\phi - 2\sin\phi + 1) = 0$$

$$\Rightarrow \sin\theta =$$

$$\frac{(1 + 2\sin\phi) \pm \sqrt{(1 + 2\sin\phi)^2 - 4(4\sin^2\phi - 2\sin\phi + 1)}}{2}$$

$$= \frac{(1 + 2\sin\phi) \pm \sqrt{-3 - 12\sin^2\phi + 12\sin\phi}}{2}$$

$$= \frac{(1 + 2\sin\phi) \pm \sqrt{-3(2\sin\phi - 1)^2}}{2}$$

since  $\sin\theta$  is real

$\therefore$  equation (i) is real only if

$$2\sin\phi - 1 = 0 \text{ or } \sin\phi = 1/2 \text{ and } \sin\theta = \frac{1+1}{2} = 1$$

$$\Rightarrow \phi = \frac{\pi}{6} \text{ and } \theta = \frac{\pi}{2} \text{ as } \theta, \phi \in [0, \pi/2]$$

22. Find the value of the given trigonometric identity:

$$\tan \frac{3\pi}{11} + 4 \sin \frac{2\pi}{11}.$$

**Solution:** Let the given identity  $\tan \frac{3\pi}{11} + 4 \sin \frac{2\pi}{11} = k$

$$\Rightarrow \frac{3 \tan \frac{\pi}{11} - \tan^3 \frac{\pi}{11}}{1 - 3 \tan^2 \frac{\pi}{11}} + \frac{8 \tan \frac{\pi}{11}}{1 + \tan^2 \frac{\pi}{11}} = k$$

$$\Rightarrow \frac{3x - x^3}{1 - 3x^2} + \frac{8x}{1 + x^2} = k \quad \left( \text{where } x = \tan \frac{\pi}{11} \right)$$

$$(11x - 22x^3 - x^5)^2 = k^2(1 - 2x^2 - 3x^4)^2 \quad \dots (1)$$

Again forming the equation whose roots are

$$\pm \tan \frac{\pi}{11}, \pm \tan \frac{2\pi}{11}, \pm \tan \frac{3\pi}{11}, \pm \tan \frac{4\pi}{11}, \pm \tan \frac{5\pi}{11},$$

it is.....

$$x^{10} - 55x^8 + 330x^6 - 462x^4 + 165x^2 - 11 = 0$$

$$\Rightarrow (11x - 22x^3 - x^5)^2 = 11(1 - 2x^2 - 3x^4)^2 \quad \dots (2)$$

Compare (1) and (2);  $k^2 = 11 \Rightarrow k = \sqrt{11}$

$$\therefore \tan \frac{3\pi}{11} + 4 \sin \frac{2\pi}{11} = \sqrt{11}$$

**Aliter:**

Let  $y =$

$$\tan \frac{3\pi}{11} + 4 \sin \frac{2\pi}{11} = \frac{1}{\cos \frac{3\pi}{11}} \left( \sin \frac{3\pi}{11} + 4 \sin \frac{2\pi}{11} \cos \frac{3\pi}{11} \right)$$

$$\Rightarrow y^2 \cdot \cos^2 \frac{3\pi}{11} = \sin^2 \frac{3\pi}{11} + 16 \sin^2 \frac{2\pi}{11}$$

$$\cos^2 \frac{3\pi}{11} + 8 \sin \frac{2\pi}{11} \cdot \cos \frac{3\pi}{11} \cdot \sin \frac{3\pi}{11}$$

1.74 > Trigonometry

$$\begin{aligned} \Rightarrow 2 \cos^2 \frac{3\pi}{11} y^2 &= 2 \sin^2 \frac{3\pi}{11} + 32 \sin^2 \frac{2\pi}{11} \\ \cos^2 \frac{3\pi}{11} + 8 \sin \frac{2\pi}{11} \cdot \sin \frac{6\pi}{11} \\ &= \left(1 - \cos \frac{6\pi}{11}\right) + 8 \left(1 - \cos \frac{4\pi}{11}\right) \\ &\quad \left(1 + \cos \frac{6\pi}{11}\right) + 4 \left(\cos \frac{4\pi}{11} - \cos \frac{8\pi}{11}\right) \\ &= 9 + 7 \cos \frac{6\pi}{11} - 4 \cos \frac{4\pi}{11} - 8 \cos \frac{4\pi}{11} \\ &\quad \cos \frac{6\pi}{11} - 4 \cos \frac{8\pi}{11} \\ &= 9 + 7 \cos \frac{6\pi}{11} - 4 \cos \frac{4\pi}{11} - \\ &\quad 4 \left(\cos \frac{10\pi}{11} + \cos \frac{2\pi}{11}\right) - 4 \cos \frac{8\pi}{11} \\ &= 9 + 11 \cos \frac{6\pi}{11} - \\ &\quad 4 \left(\cos \frac{2\pi}{11} + \cos \frac{4\pi}{11} + \cos \frac{6\pi}{11} + \cos \frac{8\pi}{11} + \cos \frac{10\pi}{11}\right) \\ &= 9 + 11 \cos \frac{6\pi}{11} - 4 \left(\frac{\cos \left(\frac{2\pi}{11} + 2 \cdot \frac{2\pi}{11}\right) \cdot \sin \left(\frac{5\pi}{11}\right)}{\sin \frac{\pi}{11}}\right) \\ &= 9 + 11 \cos \frac{6\pi}{11} - \frac{4 \cos \frac{6\pi}{11} \cdot \sin \frac{5\pi}{11}}{\sin \frac{\pi}{11}} \\ &= 9 + 11 \cos \frac{6\pi}{11} - \frac{2 \sin \frac{12\pi}{11}}{\sin \frac{\pi}{11}} \\ &= 9 + 11 \cos \frac{6\pi}{11} + 2 = 11 \left(1 + \cos \frac{6\pi}{11}\right) \\ \Rightarrow 2y^2 \cdot \left(\cos^2 \frac{3\pi}{11}\right) &= 22 \cos^2 \frac{3\pi}{11} \\ \Rightarrow y^2 &= 11 \\ \Rightarrow y &= \sqrt{11} \end{aligned}$$

23. If  $ABC$  is a triangle and  $\tan A/2, \tan B/2, \tan C/2$  are in H.P., then find the minimum value of  $\cot B/2$ .

**Solution:** We know that  $A + B + C = \pi$

$$\Rightarrow A/2 + B/2 = \pi/2 - C/2$$

$$\Rightarrow \cot(A/2 + B/2) = \cot(\pi/2 - C/2)$$

$$\Rightarrow \frac{\cot \frac{A}{2} \cdot \cot \frac{B}{2} - 1}{\cot \frac{A}{2} + \cot \frac{B}{2}} = \tan \frac{C}{2} = \frac{1}{\cot \frac{C}{2}}$$

$$\Rightarrow \cot A/2 \cot B/2 \cot C/2 = \cot A/2 + \cot B/2 + \cot C/2 \quad \dots(i)$$

But  $\tan A/2, \tan B/2, \tan C/2$  are in H.P. and hence  $\cot A/2, \cot B/2, \cot C/2$  are in A.P.

$$\Rightarrow \cot A/2 + \cot C/2 = 2 \cot B/2 \quad \dots(ii)$$

from (i) and (ii), we get,  $\cot A/2 \cot C/2 = 3$

$$\Rightarrow \text{G.M of } \cot A/2 \text{ and } \cot C/2 = \sqrt{\cot \frac{A}{2} \cot \frac{C}{2}} = \sqrt{3}$$

and A.M. of  $\cot A/2$  and  $\cot C/2$

$$= \frac{\cot \frac{A}{2} + \cot \frac{C}{2}}{2} = \cot \frac{B}{2}. \text{ But A.M} \geq \text{G.M}$$

$$\Rightarrow \cot B/2 \geq \sqrt{3}$$

$$\Rightarrow \text{minimum value of } \cot B/2 \text{ is } \sqrt{3}$$

24. If  $a_n = \cos^n \theta + \sin^n \theta$ , prove that  $6a_{10} - 15a_8 + 10a_6 - 1 = 0$

**Solution:** Let  $x^n + y^n = (x + y)(x^{n-1} - x^{n-2}y + x^{n-3}y^2 - x^{n-4}y^3 + \dots + y^{n-1})$

when  $n$  is an odd natural number.

$$a_{10} = (\cos^2 \theta)^5 + (\sin^2 \theta)^5 = \cos^8 \theta - \cos^6 \theta \sin^2 \theta + \cos^4 \theta \sin^4 \theta - \cos^2 \theta \sin^6 \theta + \sin^8 \theta$$

$$= a_8 - \cos^2 \theta \sin^2 \theta a_4 + \cos^4 \theta \sin^4 \theta$$

$$a_8 = (\cos^4 \theta)^2 + (\sin^4 \theta)^2 = (\cos^4 \theta + \sin^4 \theta)^2 - 2 \sin^4 \theta \cos^4 \theta = a_4^2 - 2 \sin^4 \theta \cos^4 \theta$$

$$a_6 = (\cos^2 \theta)^3 + (\sin^2 \theta)^3 = (\cos^4 \theta - \cos^2 \theta \sin^2 \theta + \sin^4 \theta) = a_4 - \cos^2 \theta \sin^2 \theta$$

$$a_4 = \cos^4 \theta + \sin^4 \theta = (\cos^2 \theta + \sin^2 \theta)^2 - 2 \sin^2 \theta \cos^2 \theta = 1 - 2 \sin^2 \theta \cos^2 \theta$$

$$\therefore a_6 = 1 - 3 \sin^2 \theta \cos^2 \theta$$

$$a_8 = (1 - 2 \sin^2 \theta \cos^2 \theta)^2 - 2 \sin^4 \theta \cos^4 \theta = 1 - 4 \sin^2 \theta \cos^2 \theta + 2 \sin^4 \theta \cos^4 \theta$$

$$a_{10} = a_8 - \cos^2 \theta \sin^2 \theta (1 - 2 \cos^2 \theta \sin^2 \theta) + \sin^4 \theta \cos^4 \theta$$

$$= 1 - 5 \sin^2 \theta \cos^2 \theta + 5 \sin^4 \theta \cos^4 \theta$$

$$\therefore 6a_{10} - 15a_8 + 10a_6 - 1$$

$$\begin{aligned}
 &= 6(1 - 5\sin^2\theta \cos^2\theta + 5\sin^4\theta \cos^4\theta) - \\
 &\quad 15(1 - 4\sin^2\theta \cos^2\theta + 2\sin^4\theta \cos^4\theta) + \\
 &\quad 10(1 - 3\sin^2\theta \cos^2\theta) - 1 = 0
 \end{aligned}$$

25. If  $A + B + C = \pi$ , prove that  $\cos A + \cos B + \cos C \leq 3/2$  and deduce that  $\sin A/2 \sin B/2 \sin C/2 \leq 1/8$ .

**Solution:** Let  $\cos A + \cos B + \cos C = k$

$$\Rightarrow 2\cos\left(\frac{A+B}{2}\right)\cos\left(\frac{A-B}{2}\right) + \cos(\pi - (A+B)) = k$$

$$\Rightarrow 2\cos\left(\frac{A+B}{2}\right)\cos\left(\frac{A-B}{2}\right) - 2\cos^2\left(\frac{A+B}{2}\right) + 1 = k$$

$$\begin{aligned}
 \Rightarrow 2\cos^2\left(\frac{A+B}{2}\right) - 2\cos\left(\frac{A+B}{2}\right) \\
 \cos\left(\frac{A-B}{2}\right) + k - 1 = 0 \quad \dots(i)
 \end{aligned}$$

Since  $\cos\left(\frac{A+B}{2}\right)$  is real and (i) is a quadratic equation in  $\cos\left(\frac{A+B}{2}\right)$ ;

$\therefore$  Discriminant  $\geq 0$

$$\Rightarrow 4\cos^2\left(\frac{A-B}{2}\right) - 8(k-1) \geq 0 \text{ or,}$$

$$\cos^2\left(\frac{A-B}{2}\right) \geq 2(k-1)$$

$$\Rightarrow 1 \geq 2(k-1) \left[ \because \cos^2\left(\frac{A+B}{2}\right) \leq 1 \right] \text{ or } k \leq \frac{3}{2}$$

$$\Rightarrow 2\cos\left(\frac{A+B}{2}\right)$$

$$\left[ \cos\left(\frac{A-B}{2}\right) - \cos\left(\frac{A+B}{2}\right) \right] + 1 \leq \frac{3}{2}$$

$$\Rightarrow 2\sin\frac{C}{2} \cdot 2\sin\frac{A}{2} \sin\frac{B}{2} \leq \frac{1}{2}$$

$$\Rightarrow \sin\frac{A}{2} \sin\frac{B}{2} \sin\frac{C}{2} \leq \frac{1}{8} \text{ proved}$$

26. If  $\alpha + \beta + \gamma = \pi$  and

$$\tan\left(\frac{\beta + \gamma - \alpha}{4}\right) \tan\left(\frac{\gamma + \alpha - \beta}{4}\right) \tan\left(\frac{\alpha + \beta - \gamma}{4}\right) = 1.$$

Prove that  $1 + \cos \alpha + \cos \beta + \cos \gamma = 0$

**Solution:** Let  $A = \frac{\beta + \gamma - \alpha}{4}$ ;  $B = \frac{\gamma + \alpha - \beta}{4}$ ;

$$C = \frac{\alpha + \beta - \gamma}{4}, \text{ then } \tan A \tan B \tan C = 1$$

$$\Rightarrow \frac{\sin A \sin B}{\cos A \cos B} = \frac{1}{\tan C}$$

$$\text{or } \frac{\sin A \sin B - \cos A \cos B}{\sin A \sin B + \cos A \cos B} = \frac{1 - \tan C}{1 + \tan C}$$

$$\Rightarrow -\frac{\cos(A+B)}{\cos(A-B)} = \frac{\sin\left(\frac{\pi}{4} - C\right)}{\cos\left(\frac{\pi}{4} - C\right)}$$

$$\Rightarrow 2\sin\left(\frac{\pi}{4} - C\right) \cos(A-B) +$$

$$2\cos\left(\frac{\pi}{4} - C\right) \cos(A+B) = 0$$

$$\Rightarrow \sin\left(\frac{\pi}{4} - C + A - B\right) + \sin\left(\frac{\pi}{4} - C - A + B\right) +$$

$$\cos\left(\frac{\pi}{4} - C + A + B\right) + \cos\left(\frac{\pi}{4} - C - A - B\right) = 0 \quad \dots(i)$$

$$\begin{aligned}
 \text{Now, } A - B - C &= \frac{\beta + \gamma - \alpha - \gamma - \alpha + \beta - \alpha - \beta + \gamma}{4} \\
 &= \frac{\beta + \gamma - 3\alpha}{4} = \frac{\pi - 4\alpha}{4} = \frac{\pi}{4} - \alpha
 \end{aligned}$$

$$\text{similarly } B - A - C = \frac{\pi}{4} - \beta \text{ and } C - A - B$$

$$= \frac{\pi}{4} - \gamma \text{ and } C + A + B$$

$$= \frac{\alpha + \beta + \gamma}{4} = \frac{\pi}{4}$$

$\therefore$  Equation (i) reduces to

$$\Rightarrow \sin\left(\frac{\pi}{4} + \frac{\pi}{4} - \alpha\right) + \sin\left(\frac{\pi}{4} + \frac{\pi}{4} - \beta\right) +$$

$$\cos\left(\frac{\pi}{4} - \frac{\pi}{4} + \gamma\right) + \cos\left(\frac{\pi}{4} - \frac{\pi}{4}\right) = 0$$

$$\Rightarrow \cos \alpha + \cos \beta + \cos \gamma + 1 = 0$$

27. Prove that there exist exactly two non-similar isosceles triangles where  $A, B$  and  $C$  are angles of any one of the triangles such that  $\tan A + \tan B + \tan C = 100$ .

**Solution:** Let  $A = B$ , then  $2A + C = 180^\circ$

and  $2 \tan A + \tan C = 100$

Now,  $2A + C = 180^\circ$

$\Rightarrow \tan 2A = -\tan C$  .....(i)

Also,  $2 \tan A + \tan C = 100$

$\Rightarrow 2 \tan A - 100 = -\tan C$  .....(ii)

From (i) and (ii) we have

$$2 \tan A - 100 = \frac{2 \tan A}{1 - \tan^2 A}$$

Let  $\tan A = x$ , then  $\frac{2x}{1 - x^2} = 2x - 100$

$\Rightarrow x^3 - 50x^2 + 50 = 0$

Let  $f(x) = x^3 - 50x^2 + 50$

$\Rightarrow f'(x) = 3x^2 - 100x$

Then  $f'(x) = 0$  has roots  $0, 100/3$

$$f(0) = 50 > 0, f(100/3) = (100^3/9) (1/3 - 1/2) + 50 < 0$$

$\Rightarrow$  Graph of the cubic equation  $f(x)$  is as shown below:

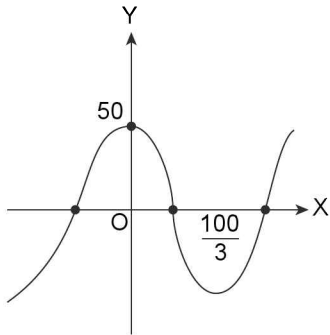

$\Rightarrow$  the curve cuts the  $x$ -axis at 3 points

$\Rightarrow$  3 possible roots of  $x$

But  $x = \tan A$

$\Rightarrow x > 0$  as  $A < 90^\circ$

So for  $x > 0$  only two roots of  $x$  are possible

$\Rightarrow$  two values of  $\tan A$  are possible

Hence  $2\Delta$ 's are possible.

28. Show  $\left( \tan^2 \frac{\pi}{7} + \tan^2 \frac{2\pi}{7} + \tan^2 \frac{3\pi}{7} \right) \left( \cot^2 \frac{\pi}{7} + \cot^2 \frac{2\pi}{7} + \cot^2 \frac{3\pi}{7} \right) = 105$

**Solution:** Let  $\theta = \frac{n\pi}{7}$ ;  $n \in \mathbb{Z}$  (so that  $7\theta = n\pi$ )

$\Rightarrow 4\theta + 3\theta = n\pi$

$\Rightarrow \tan 4\theta = \tan(n\pi - 3\theta)$

$\Rightarrow \tan 4\theta = -\tan 3\theta$

$$\Rightarrow \frac{4 \tan \theta - 4 \tan^3 \theta}{1 - 6 \tan^2 \theta + \tan^4 \theta} = - \left[ \frac{3 \tan \theta - \tan^3 \theta}{1 - 3 \tan^2 \theta} \right]$$

$$\Rightarrow \frac{4z - 4z^3}{1 - 6z^2 + z^4} = - \left[ \frac{3z - z^3}{1 - 3z^2} \right]$$

$\Rightarrow (4 - 4z^2)(1 - 3z^2) = -(3 - z^2)(1 - 6z^2 + z^4)$

$\Rightarrow z^6 - 21z^4 + 35z^2 - 7 = 0$  .....(i)

This is a cubic equation in  $z^2$  i.e., in  $\tan^2 \theta$ . The roots of this equation are therefore

$$\tan^2 \frac{\pi}{7}, \tan^2 \frac{2\pi}{7} \text{ and } \tan^2 \frac{3\pi}{7}$$

From (i), sum of the roots =  $\frac{-(-21)}{1} = 21$ .

$\Rightarrow \tan^2 \frac{\pi}{7} + \tan^2 \frac{2\pi}{7} + \tan^2 \frac{3\pi}{7} = 21$  .....(ii)

Putting  $1/y$  in place of  $z$  in equation (i), we get

$-7y^6 + 35y^4 - 21y^2 + 1 = 0$  or

$7y^6 - 35y^4 + 21y^2 - 1 = 0$  .....(iii)

This is a cubic equation in  $y^2$  i.e., in  $\cot^2 \theta$ . The roots of this equation are therefore

$$\cot^2 \frac{\pi}{7}, \cot^2 \frac{2\pi}{7} \text{ and } \cot^2 \frac{3\pi}{7}$$

$\Rightarrow$  Sum of the roots of equation (iii) =  $35/7 = 5$

$\Rightarrow \cot^2 \frac{\pi}{7} + \cot^2 \frac{2\pi}{7} + \cot^2 \frac{3\pi}{7} = 5$  .....(iv)

By multiplying (ii) and (iv) we get,

$$\left( \tan^2 \frac{\pi}{7} + \tan^2 \frac{2\pi}{7} + \tan^2 \frac{3\pi}{7} \right)$$

$$\left( \cot^2 \frac{\pi}{7} + \cot^2 \frac{2\pi}{7} + \cot^2 \frac{3\pi}{7} \right) = 21 \times 5 = 105$$

29. In any triangle  $ABC$  prove that

$$\sum \frac{\sqrt{\sin A}}{\sqrt{\sin B} + \sqrt{\sin C} - \sqrt{\sin A}} \geq 3$$
 and the equality

holds if and only if triangle is equilateral (given that

in any triangle  $\frac{a}{\sin A} = \frac{b}{\sin B} = \frac{c}{\sin C}$  where  $a, b, c$

are the sides of  $\Delta ABC$  opposite to angles  $A, B, C$ ).

**Solution:** Here,  $\frac{\sqrt{\sin A}}{\sqrt{\sin B} + \sqrt{\sin C} - \sqrt{\sin A}}$

$$= \frac{\sqrt{a}}{\sqrt{b} + \sqrt{c} - \sqrt{a}}$$

Now

$$\begin{aligned}\sqrt{b} + \sqrt{c} - \sqrt{a} &= \frac{(\sqrt{b} + \sqrt{c} - \sqrt{a})(\sqrt{b} + \sqrt{c} + \sqrt{a})}{\sqrt{b} + \sqrt{c} + \sqrt{a}} \\ &= \frac{b + c - a + 2\sqrt{bc}}{\sqrt{b} + \sqrt{c} + \sqrt{a}} > 0\end{aligned}$$

Hence,  $\sqrt{b} + \sqrt{c} - \sqrt{a} > 0$

Let  $\sqrt{b} + \sqrt{c} - \sqrt{a} = x$ ,  $\sqrt{c} + \sqrt{a} - \sqrt{b} = y$ ,

$$\sqrt{a} + \sqrt{b} - \sqrt{c} = z$$

$$\therefore \frac{\sqrt{\sin A}}{\sqrt{\sin B} + \sqrt{\sin C} - \sqrt{\sin A}} = \frac{y+z}{2x}$$

$$\begin{aligned}\Rightarrow & \sum \frac{\sqrt{\sin A}}{\sqrt{\sin B} + \sqrt{\sin C} - \sqrt{\sin A}} \\ &= \frac{1}{2} \left\{ \frac{y}{x} + \frac{z}{x} \right\} + \frac{1}{2} \left\{ \frac{x}{y} + \frac{z}{y} \right\} + \frac{1}{2} \left\{ \frac{x}{z} + \frac{y}{z} \right\} \\ &= \frac{1}{2} \left\{ \frac{y}{x} + \frac{x}{y} \right\} + \frac{1}{2} \left\{ \frac{x}{z} + \frac{z}{x} \right\} + \frac{1}{2} \left\{ \frac{y}{z} + \frac{z}{y} \right\}\end{aligned}$$

which is greater than or equal to 3, as each term

$\frac{1}{2} \left( \frac{x}{y} + \frac{y}{x} \right)$  is greater than or equal to 1 (using A. M.  $\geq$  G.M)

Now equality hold if and only if  $\frac{x}{y} = \frac{y}{z} = \frac{z}{x} = 1$  i.e.,

$$x = y = z$$

$\Rightarrow a = b = c$  i.e., triangle is equilateral

**30.** Find the roots of the following cubic equation

$$2x^3 - 3x^2 \cos(A - B) - 2x \cos^2(A + B) + \sin 2A \cdot \sin 2B \cdot \cos(A - B) = 0$$

**Solution:** We know that  $\sin 2A \cdot \sin 2B$

$$= \frac{1}{2} [\cos(2A - 2B) - \cos(2A + 2B)]$$

$$= \frac{1}{2} [2\cos^2(A - B) - 1 - 2\cos^2(A + B) + 1]$$

$$= \cos^2(A - B) - \cos^2(A + B)$$

$$\therefore \sin 2A \cdot \sin 2B = \cos^2(A - B) - \cos^2(A + B) \quad \dots(i)$$

$$\text{Now } 2x^3 - 3x^2 \cos(A - B) - 2x \cos^2(A + B) + \sin 2A \cdot \sin 2B \cdot \cos(A - B) = 0$$

$$\begin{aligned}\Rightarrow & 2x^3 - 3x^2 \cos(A - B) - 2x \cos^2(A + B) + \\ & \cos^3(A - B) - \cos^2(A + B) \cdot \cos(A - B) = 0\end{aligned}$$

By inspection it find that  $x = -1/2 \cos(A - B)$  because

$$\left( -\frac{1}{4} - \frac{3}{4} + 1 \right) \cos^3(A - B) + \cos^2(A + B).$$

$$\cos(A - B) - \cos^2(A + B) \cdot \cos(A - B) = 0$$

Hence  $2x + \cos(A - B)$  is factor of the given equation which when divided by it gives the other factor as,  $x^2 - 2x \cos(A - B) + \cos^2(A - B) - \cos^2(A + B) = 0$

$$\text{So, } x = \frac{2\cos(A - B) \pm \sqrt{4\cos^2(A - B) - 4\cos^2(A + B)}}{2}$$

$$\Rightarrow x = \frac{2\cos(A - B) \pm 2\cos(A + B)}{2}$$

$$x = \cos(A - B) + \cos(A + B) \text{ or } \cos(A - B) - \cos(A + B)$$

Hence the roots are  $(2\cos A \cos B)$ ,  $2\sin A \sin B$  and

$$-\frac{1}{2}\cos(A + B)$$

**31.** Find the value of  $4\cos 36^\circ + \cot\left(\frac{15}{2}\right)^\circ$ .

**Solution:** We have already established that

$$\sin 18^\circ = \frac{\sqrt{5} - 1}{4}$$

$$\Rightarrow \sin 54^\circ = 3 \sin 18^\circ - 4 \sin^3 18^\circ$$

$$= 3 \left( \frac{\sqrt{5} - 1}{4} \right) - 4 \left( \frac{\sqrt{5} - 1}{4} \right)^3$$

$$= \left( \frac{\sqrt{5} - 1}{4} \right) \left[ 3 - 4 \left( \frac{\sqrt{5} - 1}{4} \right)^2 \right]$$

$$= \left( \frac{\sqrt{5} - 1}{4} \right) \left[ 3 - 4 \left( \frac{5 + 1 - 2\sqrt{5}}{4 \times 4} \right) \right]$$

$$= \frac{\sqrt{5} - 1}{16} [12 - 6 + 2\sqrt{5}] = \frac{\sqrt{5} - 1}{16} (6 + 2\sqrt{5})$$

$$= \frac{\sqrt{5} - 1}{16} \times \left( (\sqrt{5})^2 + 1^2 + 2 \times \sqrt{5} \right) = \frac{5 - 1}{16} \times (\sqrt{5} + 1)$$

$$= \frac{\sqrt{5} + 1}{4}$$

$$\Rightarrow \cos 36^\circ = \frac{\sqrt{5} + 1}{4} \Rightarrow 4 \cos 36^\circ = \sqrt{5} + 1$$

$$\cot\left(\frac{15}{2}\right)^\circ = \frac{\cos\left(\frac{15}{2}\right)^\circ}{\sin\left(\frac{15}{2}\right)^\circ}$$

Multiplying numerator and denominator by

$$\cos\left(\frac{15}{2}\right)^\circ \text{ we get,}$$

$$\begin{aligned} \cot\left(\frac{15}{2}\right)^\circ &= \frac{\cos^2\left(\frac{15}{2}\right)^\circ}{\sin\left(\frac{15}{2}\right)^\circ \cos\left(\frac{15}{2}\right)^\circ} = \frac{2\cos^2\left(\frac{15}{2}\right)^\circ}{\sin 15^\circ} \\ &= \frac{1 + \cos 15^\circ}{\sin 15^\circ} \end{aligned}$$

$$\text{now } \cos 15^\circ = \cos(45^\circ - 30^\circ) = \frac{1 + \sqrt{3}}{2\sqrt{2}}$$

$$\sin 15^\circ = \sin(45^\circ - 30^\circ) = \frac{\sqrt{3} - 1}{2\sqrt{2}}$$

$$\Rightarrow \cot\left(\frac{15}{2}\right)^\circ = \frac{1 + \frac{1 + \sqrt{3}}{2\sqrt{2}}}{\frac{\sqrt{3} - 1}{2\sqrt{2}}} = \frac{2\sqrt{2} + 1 + \sqrt{3}}{\sqrt{3} - 1}$$

Rationalizing ; we get,

$$\cot\left(\frac{15}{2}\right)^\circ = \frac{(2\sqrt{2} + 1 + \sqrt{3})(\sqrt{3} + 1)}{2} = \sqrt{2} + \sqrt{3} + \sqrt{4} + \sqrt{6}$$

$$\therefore 4\cos 36^\circ + \cot\left(\frac{15}{2}\right)^\circ = \sqrt{1} + \sqrt{2} + \sqrt{3} + \sqrt{4} + \sqrt{5} + \sqrt{6}$$

**32.** Prove that  $\cot^2 A + \cot^2 B + \cot^2 C \geq 1$

if it is given that  $A, B, C$  are the angles of a triangle.

**Solution:** Since, we already know that for  $A + B + C = \pi$ , we have  $\tan A + \tan B + \tan C = \tan A \tan B \tan C$

$$\Rightarrow \frac{1}{\cot A} + \frac{1}{\cot B} + \frac{1}{\cot C} = \frac{1}{\cot A \cot B \cot C}$$

$$\Rightarrow \cot A \cot B + \cot B \cot C + \cot A \cot C = 1$$

Substituting this value of 1 in the inequality, we get,  $\cot^2 A + \cot^2 B + \cot^2 C \geq \cot A \cot B + \cot B \cot C + \cot A \cot C$

$$\Rightarrow 2\cot^2 A + 2\cot^2 B + 2\cot^2 C - 2\cot A \cot B - \cot B \cot C - 2\cot A \cot C \geq 0$$

$$\begin{aligned} \Rightarrow (\cot A - \cot B)^2 + (\cot B - \cot C)^2 \\ + (\cot C - \cot A)^2 \geq 0 \end{aligned}$$

which is obviously true and hence proved.

**33.** Prove that

$$\frac{\cos\left(\frac{A-B}{2}\right)}{\cos\left(\frac{A+B}{2}\right)} + \frac{\cos\left(\frac{B-C}{2}\right)}{\cos\left(\frac{B+C}{2}\right)} + \frac{\cos\left(\frac{C-A}{2}\right)}{\cos\left(\frac{C+A}{2}\right)} \geq 6$$

**Solution:** Let  $x = \frac{\cos\left(\frac{A-B}{2}\right)}{\cos\left(\frac{A+B}{2}\right)} \times \frac{2\sin\left(\frac{A+B}{2}\right)}{2\sin\left(\frac{A+B}{2}\right)}$

$$\begin{aligned} \Rightarrow x &= \frac{\sin A + \sin B}{\sin(A+B)} = \frac{\sin A + \sin B}{\sin(\pi - C)} \\ &= \frac{\sin A}{\sin C} + \frac{\sin B}{\sin C} \end{aligned}$$

Similarly,  $\frac{\cos\left(\frac{B-C}{2}\right)}{\cos\left(\frac{B+C}{2}\right)} = \frac{\sin B}{\sin A} + \frac{\sin C}{\sin A}$  and

$$\frac{\cos\left(\frac{C-A}{2}\right)}{\cos\left(\frac{C+A}{2}\right)} = \frac{\sin C}{\sin B} + \frac{\sin A}{\sin B}$$

Applying  $AM \geq GM$  we get,

$$\frac{\sin A}{\sin C} + \frac{\sin B}{\sin C} + \frac{\sin B}{\sin A} + \frac{\sin C}{\sin A} + \frac{\sin C}{\sin B} + \frac{\sin A}{\sin B} \geq 6$$

and hence

$$\frac{\cos\left(\frac{A-B}{2}\right)}{\cos\left(\frac{A+B}{2}\right)} + \frac{\cos\left(\frac{B-C}{2}\right)}{\cos\left(\frac{B+C}{2}\right)} + \frac{\cos\left(\frac{C-A}{2}\right)}{\cos\left(\frac{C+A}{2}\right)} \geq 6$$

**34.** If  $\frac{1}{\cos \alpha \cdot \cos \beta} + \tan \alpha \cdot \tan \beta = \tan \gamma$ ; where  $0 < \gamma < \pi/2$  and  $\alpha, \beta$  are positive acute angles show that,  $\pi/4 < \gamma < \pi/2$ .

**Solution:** Since  $\tan \gamma = \frac{1}{\cos \alpha \cdot \cos \beta} + \tan \alpha \cdot \tan \beta$

Now  $1 - \tan^2 \gamma$  .....(i)

$$\begin{aligned}
 &= 1 - \left( \frac{1}{\cos \alpha \cos \beta} + \tan \alpha \cdot \tan \beta \right)^2 \\
 &= 1 - \left( \frac{1 + \sin \alpha \cdot \sin \beta}{\cos \alpha \cos \beta} \right)^2 \\
 &= \frac{\cos^2 \alpha \cos^2 \beta - \sin^2 \alpha \sin^2 \beta - 1 - 2 \sin \alpha \sin \beta}{\cos^2 \alpha \cos^2 \beta} \\
 &= \frac{\cos(\alpha + \beta) \cdot \cos(\alpha - \beta) - 1 - 2 \sin \alpha \sin \beta}{\cos^2 \alpha \cos^2 \beta} \\
 &= \frac{\cos^2 \alpha - \sin^2 \beta - 1 - 2 \sin \alpha \sin \beta}{\cos^2 \alpha \cos^2 \beta} \\
 &= - \frac{(\sin^2 \alpha + \sin^2 \beta + 2 \sin \alpha \sin \beta)}{\cos^2 \alpha \cos^2 \beta} \\
 &= - \frac{(\sin \alpha + \sin \beta)^2}{\cos^2 \alpha \cos^2 \beta} < 0
 \end{aligned}$$

(because, if it is equal to zero then  $\sin \alpha + \sin \beta = 0$ )

$$\text{or } 2 \sin \left( \frac{\alpha + \beta}{2} \right) \cos \left( \frac{\alpha - \beta}{2} \right) = 0$$

⇒ Either  $\frac{\alpha - \beta}{2} = (2m + 1) \frac{\pi}{2}$  or  $\frac{\alpha + \beta}{2} = n\pi$  which is impossible as  $\alpha, \beta \in (0, \pi/2)$

Thus from (i),  $1 - \tan^2 \gamma < 0 \Rightarrow \tan^2 \gamma - 1 > 0$

⇒  $\tan \gamma > 1$  as  $0 < \gamma < \pi/2$

⇒  $\gamma > \pi/4$  ∴  $\pi/4 < \gamma < \pi/2$

35. In  $\Delta ABC$ , prove that  $\operatorname{cosec} \frac{A}{2} + \operatorname{cosec} \frac{B}{2} + \operatorname{cosec} \frac{C}{2} \geq 6$ .

**Solution:** Since  $A/2, B/2, C/2$  all are acute angles, we can use A.M.  $\geq$  G.M

$$\text{i.e., } \frac{\operatorname{cosec} \frac{A}{2} + \operatorname{cosec} \frac{B}{2} + \operatorname{cosec} \frac{C}{2}}{3} \geq$$

$$\left( \operatorname{cosec} \frac{A}{2} \cdot \operatorname{cosec} \frac{B}{2} \cdot \operatorname{cosec} \frac{C}{2} \right)^{1/3} \quad \dots(i)$$

Consider,

$$\sin \frac{A}{2} \cdot \sin \frac{B}{2} \cdot \sin \frac{C}{2} = \frac{1}{2} \sin \frac{A}{2} \cdot \left( 2 \sin \frac{B}{2} \cdot \sin \frac{C}{2} \right)$$

$$= \frac{1}{2} \sin \frac{A}{2} \left( \cos \left( \frac{B-C}{2} \right) - \cos \left( \frac{B+C}{2} \right) \right)$$

$$= \frac{1}{2} \sin \frac{A}{2} \left( \cos \left( \frac{B-C}{2} \right) - \sin \left( \frac{A}{2} \right) \right)$$

$$\leq \frac{1}{2} \sin \frac{A}{2} \left( 1 - \sin \left( \frac{A}{2} \right) \right) \text{ because } \cos \left( \frac{B-C}{2} \right) \leq 1$$

$$= \frac{1}{2} \left( \sin \frac{A}{2} - \sin^2 \frac{A}{2} \right) \leq \frac{1}{2} \left( \frac{1}{4} - \left( \frac{1}{2} - \sin \frac{A}{2} \right)^2 \right) \leq 1/8$$

$$\therefore \operatorname{cosec} \frac{A}{2} \cdot \operatorname{cosec} \frac{B}{2} \cdot \operatorname{cosec} \frac{C}{2} \geq 8 \quad \dots(ii)$$

$$\Rightarrow \frac{\operatorname{cosec} \frac{A}{2} + \operatorname{cosec} \frac{B}{2} + \operatorname{cosec} \frac{C}{2}}{3} \geq (8)^{1/3}$$

$$\Rightarrow \operatorname{cosec} \frac{A}{2} + \operatorname{cosec} \frac{B}{2} + \operatorname{cosec} \frac{C}{2} \geq 6$$

36. If  $2[\cos(\alpha - \beta) + \cos(\beta - \gamma) + \cos(\gamma - \alpha)] + 3 = 0$ , prove that

$$\begin{aligned}
 &\frac{d\alpha}{\sin(\beta + \theta) \sin(\gamma + \theta)} + \frac{d\beta}{\sin(\alpha + \theta) \sin(\gamma + \theta)} + \\
 &\frac{d\gamma}{\sin(\alpha + \theta) \sin(\beta + \theta)} = 0;
 \end{aligned}$$

where  $\theta$  is any real angle such that  $\alpha + \theta, \beta + \theta, \gamma + \theta$  are not the multiple of  $\pi$ .

**Solution:**

Given

$$2[\cos(\alpha - \beta) + \cos(\beta - \gamma) + \cos(\gamma - \alpha)] + 3 = 0$$

$$\Rightarrow 2[\cos\{\alpha + \theta - (\beta + \theta)\} + \cos\{\beta + \theta - (\gamma + \theta)\} + \cos\{\gamma + \theta - (\alpha + \theta)\}] + 3 = 0$$

$$\Rightarrow 2[\cos(\alpha + \theta) \cdot \cos(\beta + \theta) + \sin(\alpha + \theta) \cdot$$

$$\sin(\beta + \theta) + \dots + \dots] + \{\sin^2(\alpha + \theta) \cdot$$

$$\cos^2(\alpha + \theta) + \sin^2(\beta + \theta) + \cos^2(\beta + \theta) +$$

$$\sin^2(\gamma + \theta) + \cos^2(\gamma + \theta)\} = 0$$

$$\Rightarrow [\sin(\gamma + \theta) + \sin(\beta + \theta) + \sin(\alpha + \theta)]^2 +$$

$$[\cos(\alpha + \theta) + \cos(\beta + \theta) + \cos(\gamma + \theta)]^2 = 0$$

which is only possible if

$$\sin(\alpha + \theta) + \sin(\beta + \theta) + \sin(\gamma + \theta) = 0 \quad \dots(i)$$

$$\text{and } \cos(\alpha + \theta) + \cos(\beta + \theta) + \cos(\gamma + \theta) = 0 \quad \dots(ii)$$

From (ii), we get

$$d(\cos(\alpha + \theta) + \cos(\beta + \theta) + \cos(\gamma + \theta)) = 0$$

$$\Rightarrow \sin(\alpha + \theta) \cdot d\alpha + \sin(\beta + \theta) \cdot d\beta + \sin(\gamma + \theta) \cdot d\gamma = 0$$

$$\Rightarrow \frac{d\alpha}{\sin(\beta + \theta) \sin(\gamma + \theta)} + \frac{d\beta}{\sin(\alpha + \theta) \sin(\gamma + \theta)} +$$

$$\frac{d\gamma}{\sin(\alpha + \theta) \sin(\beta + \theta)} = 0$$



37. Find all the solutions of the equation  $x^2 - 3 \left[ \sin \left( x - \frac{\pi}{6} \right) \right] = 3$  where  $[.]$  represents the greatest integer function.

**Solution:** The given equation can be rewritten as,  $x^2 - 3 = 3 \left[ \sin \left( x - \frac{\pi}{6} \right) \right]$

Here right hand side can take only the values  $-3, 0, 3$

**Case I:** When  $x^2 - 3 = -3 \Rightarrow x = 0$

at  $x = 0$ ,  $\left[ \sin \left( x - \frac{\pi}{6} \right) \right] = -1$ , so  $x = 0$  is a solution

**Case II:** When  $x^2 - 3 = 0 \Rightarrow x = \sqrt{3}$

Now at  $x = \sqrt{3}$ ,  $\left[ \sin \left( x - \frac{\pi}{6} \right) \right] = 0 \Rightarrow \sqrt{3}$

But at  $x = -\sqrt{3}$ ,  $[\sin(x - \pi/6)] = -1$ , hence  $x = -\sqrt{3}$  is not a solution

**Case III:** When  $x^2 - 3 = 3 \Rightarrow x = \pm\sqrt{6}$

But  $\left[ \sin \left( \pm\sqrt{6} - \frac{\pi}{6} \right) \right] \neq 1 \Rightarrow x = \pm\sqrt{6}$  is not a solution

Hence the given equation has only two solutions  $x = 0, \sqrt{3}$

38. Show that the equation  $\sec\theta + \operatorname{cosec}\theta = c$  has two roots between 0 and  $2\pi$  if  $2 < c^2 < 8$ .

**Solution:** Here  $\frac{1}{\cos\theta} + \frac{1}{\sin\theta} = c$  or  $\sin\theta + \cos\theta = c \sin\theta \cos\theta$

$$\therefore (\sin\theta + \cos\theta)^2 = c^2 \sin^2\theta \cos^2\theta$$

$$\text{or } 1 + 2\sin\theta \cos\theta = \frac{c^2}{4} \sin^2 2\theta \text{ or } c^2 \sin^2 2\theta - 4 \sin 2\theta - 4 = 0$$

$$\therefore \sin 2\theta = \frac{4 \pm \sqrt{16 + 16c^2}}{2c^2} = \frac{2 \pm 2\sqrt{1+c^2}}{c^2}$$

As  $1 + c^2 > 0$ ,  $\sin^2\theta$  has two real solutions provided  $-1 \leq \sin 2\theta \leq 1$

$$\text{i.e., } -1 \leq \frac{2 \pm 2\sqrt{1+c^2}}{c^2} \leq 1 \quad \dots(i)$$

Also, corresponding to each value of  $\sin 2\theta$ , we get two values for  $\theta$  between 0 and  $2\pi$ .

$$\text{Clearly, } -1 < \frac{2 + 2\sqrt{1+c^2}}{c^2} \text{ and } \frac{2 - 2\sqrt{1+c^2}}{c^2} < 1$$

$$\therefore (i) \text{ is satisfied if } -1 \leq \frac{2 - 2\sqrt{1+c^2}}{c^2} \text{ and}$$

$$\frac{2 + 2\sqrt{1+c^2}}{c^2} < 1$$

$$\text{Now } -1 \leq \frac{2 - 2\sqrt{1+c^2}}{c^2} \Rightarrow -c^2 \leq 2 - 2\sqrt{1+c^2}$$

$$\Rightarrow 2\sqrt{1+c^2} \leq 2 + c^2 \Rightarrow 4(1+c^2) \leq (2+c^2)^2$$

$$\Rightarrow 0 \leq c^4 \text{ which is true}$$

$$\text{and } \frac{2 + 2\sqrt{1+c^2}}{c^2} < 1 \Rightarrow 2 + 2\sqrt{1+c^2} < c^2$$

$$\Rightarrow 2\sqrt{1+c^2} < c^2 - 2 \quad \{c^2 - 2 \text{ is positive}\}$$

$$\Rightarrow 4(1+c^2) < c^4 - 4c^2 + 4 \Rightarrow c^2 - 8 > 0$$

$$\Rightarrow c^2 > 8 \text{ But } c^2 < 8 \text{ (given).}$$

$$\text{Hence only admissible value of } \sin 2\theta \text{ is } \frac{2 - 2\sqrt{1+c^2}}{c^2}$$

when  $2 < c^2 < 8$

So  $\theta$  has two roots between 0 and  $2\pi$ .

39. In a  $\Delta ABC$ , if  $\cot A + \cot B + \cot C = \sqrt{3}$ , prove that the triangle is equilateral.

**Solution:** In  $\Delta ABC$ ,  $A + B + C = \pi$

Using the inequalities covered, we already know that

$$\cot A \cot B + \cot B \cot C + \cot C \cot A = 1 \quad \dots(1)$$

$$\text{Again, given } \cot A + \cot B + \cot C = \sqrt{3}$$

$$\Rightarrow (\cot A + \cot B + \cot C)^2 = 3$$

$$\Rightarrow \cot^2 A + \cot^2 B + \cot^2 C + 2(\cot A \cot B + \cot B \cot C + \cot C \cot A) = 3$$

$$\Rightarrow \cot^2 A + \cot^2 B + \cot^2 C + 2 \times 1 = 3 \quad (\text{from (1)})$$

$$\Rightarrow \cot^2 A + \cot^2 B + \cot^2 C = 3 - 2 = 1$$

$$\Rightarrow 2(\cot^2 A + \cot^2 B + \cot^2 C) = 2 \times 1$$

$$\Rightarrow 2\cot^2 A + 2\cot^2 B + 2\cot^2 C - 2 \times 1 = 0$$

$$\Rightarrow 2\cot^2 A + 2\cot^2 B + 2\cot^2 C - 2(\cot A \cot B + \cot B \cot C + \cot C \cot A) = 0 \quad [\text{using (1)}]$$

$$\Rightarrow \cot^2 A + \cot^2 B - 2\cot A \cot B + \cot^2 B + \cot^2 C - 2\cot B \cot C + \cot^2 C + \cot^2 A - 2\cot C \cot A = 0$$

$$\Rightarrow (\cot A - \cot B)^2 + (\cot B - \cot C)^2 + (\cot C - \cot A)^2 = 0$$

which is possible only when.

$$(\cot A - \cot B)^2 = 0, \quad \text{i.e., } \cot A = \cot B$$

$$\text{and } (\cot B - \cot C)^2 = 0, \quad \text{i.e., } \cot B = \cot C$$

$$\text{and } (\cot C - \cot A)^2 = 0 \text{ i.e., } \cot C = \cot A$$

$$\text{Hence, } \cot A = \cot B = \cot C$$

$$\text{or, } A = B = C$$

Hence,  $\Delta ABC$  is equilateral.

40. Prove that  $\sin \frac{2\pi}{7} + \sin \frac{4\pi}{7} + \sin \frac{8\pi}{7} = \frac{\sqrt{7}}{2}$ .

**Method I:** Let  $x$  be the seventh root of unity

$$\Rightarrow x = 1^{1/7}$$

$$x = \cos \frac{2k\pi}{7} + i \sin \frac{2k\pi}{7}$$

$$\Rightarrow x = e^{i2k\pi/7} \text{ (where } k = 0, 1, 2, 3, 4, 5, 6)$$

$$\sum_{k=0}^6 e^{i2k\pi/7} = 0 \Rightarrow 1 + \sum_{k=1}^6 e^{i2k\pi/7} = 0$$

$$\Rightarrow 1 + \sum_{k=1}^3 (e^{i2k\pi/7} + e^{-i2k\pi/7}) = 0$$

$$\Rightarrow 1 + \sum_{k=1}^3 2 \cos \frac{2k\pi}{7} = 0$$

$$\Rightarrow 1 + 2 \sum_{k=1}^3 \left(1 - 2 \sin^2 \frac{k\pi}{7}\right) = 0$$

$$\Rightarrow 1 + 2 \left[ 3 - 2 \left( \sin^2 \frac{\pi}{7} + \sin^2 \frac{2\pi}{7} + \sin^2 \frac{3\pi}{7} \right) \right] = 0$$

$$\Rightarrow \sin^2 \frac{\pi}{7} + \sin^2 \frac{2\pi}{7} + \sin^2 \frac{3\pi}{7} = \frac{7}{4}$$

$$\Rightarrow \sin^2 \frac{8\pi}{7} + \sin^2 \frac{2\pi}{7} + \sin^2 \frac{4\pi}{7} = \frac{7}{4}$$

$$\text{or } \sin^2 \frac{2\pi}{7} + \sin^2 \frac{4\pi}{7} + \sin^2 \frac{8\pi}{7} = \frac{7}{4}$$

$$\text{and } \sin \frac{2\pi}{7} \cdot \sin \frac{4\pi}{7} + \sin \frac{4\pi}{7} \cdot \sin \frac{8\pi}{7} + \sin \frac{8\pi}{7} \cdot \sin \frac{2\pi}{7}$$

$$= \frac{1}{2} \left( \begin{array}{l} \cos \frac{2\pi}{7} - \cos \frac{6\pi}{7} + \cos \frac{4\pi}{7} - \\ \cos \frac{12\pi}{7} + \cos \frac{6\pi}{7} - \cos \frac{10\pi}{7} \end{array} \right)$$

$$\frac{1}{2} \left( \cos \frac{2\pi}{7} + \cos \frac{4\pi}{7} - \cos \left( 2\pi - \frac{2\pi}{7} \right) - \cos \left( 2\pi - \frac{4\pi}{7} \right) \right)$$

$$\frac{1}{2} \left( \cos \frac{2\pi}{7} + \cos \frac{4\pi}{7} - \cos \frac{2\pi}{7} - \cos \frac{4\pi}{7} \right) = 0$$

$$\text{so } \left( \sin \frac{2\pi}{7} + \sin \frac{4\pi}{7} + \sin \frac{8\pi}{7} \right)^2 =$$

$$\sin^2 \frac{2\pi}{7} + \sin^2 \frac{4\pi}{7} + \sin^2 \frac{8\pi}{7} = \frac{7}{4}$$

$$\text{or } \sin \frac{2\pi}{7} + \sin \frac{4\pi}{7} + \sin \frac{8\pi}{7} = \frac{\sqrt{7}}{2}$$

**Method II:** Consider  $\frac{2n\pi}{7} = \theta$

$$2n\pi = 7\theta = 4\theta + 3\theta$$

$4\theta = 2n\pi - 3\theta$ , taking  $\sin$  of both side; we get,

$$\sin 4\theta = \sin(2n\pi - 3\theta) = -\sin 3\theta \quad \dots(i)$$

This means  $\sin \theta$  takes the values  $0, \pm \sin(2\pi/7), \pm \sin(4\pi/7)$  and  $\pm \sin(8\pi/7)$

Since  $\sin(6\pi/7) = \sin(8\pi/7)$

From (1), we now get  $2 \sin 2\theta \cos 2\theta = 4 \sin^3 \theta - 3 \sin \theta$

$$\Rightarrow 4 \sin \theta \cos \theta (1 - 2 \sin^2 \theta) = \sin \theta (4 \sin^2 \theta - 3)$$

Rejecting the value  $\sin \theta = 0$ , this implies

$$4 \cos \theta (1 - 2 \sin^2 \theta) = 4 \sin^2 \theta - 3$$

$$\Rightarrow 16 \cos^2 \theta (1 - 2 \sin^2 \theta)^2 = (4 \sin^2 \theta - 3)^2$$

$$\Rightarrow 16(1 - \sin^2 \theta) (1 - 4 \sin^2 \theta + 4 \sin^4 \theta) = 16 \sin^4 \theta - 24 \sin^2 \theta + 9$$

$$\Rightarrow 64 \sin^6 \theta - 112 \sin^4 \theta + 56 \sin^2 \theta - 7 = 0$$

This is a cubic in  $\sin^2 \theta$  with the roots  $\sin^2(2\pi/7)$ ,  $\sin^2(4\pi/7)$ , and  $\sin^2(8\pi/7)$

The sum of these roots is.

$$\sin^2 \frac{2\pi}{7} + \sin^2 \frac{4\pi}{7} + \sin^2 \frac{8\pi}{7} = \frac{112}{64} = \frac{7}{4}$$

$$\Rightarrow \sin \frac{2\pi}{7} + \sin \frac{4\pi}{7} + \sin \frac{8\pi}{7} = \frac{\sqrt{7}}{2}$$

**Method III:** Let  $x = \sin \frac{2\pi}{7} + \sin \frac{4\pi}{7} + \sin \frac{8\pi}{7}$

Squaring both sides, we get

$$x^2 = \sin^2 \frac{2\pi}{7} + \sin^2 \frac{4\pi}{7} + \sin^2 \frac{8\pi}{7} + 2 \sin \frac{2\pi}{7}$$

$$\sin \frac{4\pi}{7} + 2 \sin \frac{4\pi}{7} \sin \frac{8\pi}{7} + 2 \sin \frac{8\pi}{7} \sin \frac{2\pi}{7}$$

We have already proved that

$$2 \sin \frac{2\pi}{7} \sin \frac{4\pi}{7} + 2 \sin \frac{4\pi}{7} \sin \frac{8\pi}{7} + 2 \sin \frac{8\pi}{7} \sin \frac{2\pi}{7} = 0$$

$$\text{So, } x^2 = \sin^2 \frac{2\pi}{7} + \sin^2 \frac{4\pi}{7} + \sin^2 \frac{8\pi}{7}$$

$$= \frac{1 - \cos \frac{4\pi}{7}}{2} + \frac{1 - \cos \frac{8\pi}{7}}{2} + \frac{1 - \cos \frac{16\pi}{7}}{2}$$

$$= \frac{1}{2} \left[ 3 - \left( \cos \frac{4\pi}{7} + \cos \frac{8\pi}{7} + \cos \frac{16\pi}{7} \right) \right]$$

$$= \frac{1}{2} \left[ 3 - \left( \cos \frac{2\pi}{7} + \cos \frac{4\pi}{7} + \cos \frac{6\pi}{7} \right) \right]$$

$$\begin{aligned}
 &= \frac{1}{2} \left[ 3 - \frac{1}{2 \sin \pi/7} \left\{ \begin{array}{l} 2 \sin \frac{\pi}{7} \cos \frac{2\pi}{7} + 2 \sin \frac{\pi}{7} \\ \cos \frac{4\pi}{7} + 2 \sin \frac{\pi}{7} \cos \frac{6\pi}{7} \end{array} \right\} \right] \\
 &= \frac{1}{2} \left[ 3 - \frac{1}{2 \sin \pi/7} \left\{ \begin{array}{l} \left( \sin \frac{\pi}{7} - \sin \frac{\pi}{7} \right) + \\ \left( \sin \frac{5\pi}{7} - \sin \frac{3\pi}{7} \right) + \\ \left( \sin \frac{7\pi}{7} \sin \frac{5\pi}{7} \right) \end{array} \right\} \right] \\
 &= \frac{1}{2} \left[ 3 + \frac{1}{2} \right] = \frac{7}{4} \Rightarrow x = +\frac{\sqrt{7}}{2} \\
 &\left[ \begin{array}{l} \text{since } x = \sin \frac{2\pi}{7} + \sin \frac{4\pi}{7} + \sin \frac{8\pi}{7} = \\ \sin \frac{2\pi}{7} + \sin \frac{4\pi}{7} - \sin \frac{\pi}{7} > 0 \left( \because \sin \frac{2\pi}{7} > \sin \frac{\pi}{7} \right) \end{array} \right]
 \end{aligned}$$

41. Let  $a_1, a_2, \dots, a_n$  be real constants,  $x$  be a real variable and  $f(x) = \cos(a_1 + x) + \frac{1}{2} \cos(a_2 + x) + \frac{1}{2^2} \cos(a_3 + x) + \dots + \frac{1}{2^{n-1}} \cos(a_n + x)$ . Given that  $f(x_1) = f(x_2) = 0$ , prove that  $x_2 - x_1 = m\pi$  for some integer  $m$ .

**Solution:**  $f(x)$  may be written in the form,  $f(x) =$

$$\sum_{k=1}^n \frac{1}{2^{k-1}} \cos(a_k + x) = \sum_{k=1}^n \frac{1}{2^{k-1}} (\cos a_k \cos x - \sin a_k \sin x)$$

$$= \left( \sum_{k=1}^n \frac{1}{2^{k-1}} \cos a_k \right) \cos x - \left( \sum_{k=1}^n \frac{1}{2^{k-1}} \sin a_k \right) \sin x$$

$= A \cos x - B \sin x$ , where

$$A = \sum_{k=1}^n \frac{1}{2^{k-1}} \cos a_k, \quad B = \sum_{k=1}^n \frac{1}{2^{k-1}} \sin a_k$$

Now  $A$  and  $B$  both can't be zero, for if they were then  $f(x)$  would vanish identically.

$$\text{Now } f(x_1) = A \cos x_1 - B \sin x_1 = 0$$

$$f(x_2) = A \cos x_2 - B \sin x_2 = 0 \Rightarrow \tan x_1 = A/B, \tan x_2 = A/B \Rightarrow \tan x_1 = \tan x_2 \Rightarrow x_2 - x_1 = m\pi, m \in \mathbb{Z}.$$

**Column Match Type**

42. If  $0 \leq x \leq 2\pi$ , then match the entries in Column A to the corresponding entries in Column B.

**Column-A**

- (i)  $\sin \frac{x}{2}$  if  $\tan x = -\frac{4}{3}$ ,  $x$  lies in quadrant II
- (ii)  $\sin \frac{x}{2}$  if  $\cos x = -\frac{1}{3}$ ,  $x$  lies in quadrant III
- (iii)  $\tan \frac{x}{2}$  if  $\sin x = -\frac{1}{2}$ ,  $x$  lies in quadrant IV

**Column-B**

- (a)  $-\sqrt{\frac{2-\sqrt{3}}{2+\sqrt{3}}}$
- (b)  $\frac{2}{\sqrt{5}}$
- (c)  $\sqrt{\frac{2}{3}}$

**Solution:** (i)  $\rightarrow$  (b), (ii)  $\rightarrow$  (c), (iii)  $\rightarrow$  (a)

(i) It is given that  $x$  lies in II<sup>nd</sup> quadrant in which  $\cos x$  is negative.

$$\therefore \cos x = -\frac{1}{\sqrt{1+\tan^2 x}} = -\frac{1}{\sqrt{1+16/9}} = -\frac{3}{5}$$

Now,  $x$  lies in II<sup>nd</sup> quadrant

$$\Rightarrow \frac{\pi}{2} < x < \pi \Rightarrow \frac{\pi}{4} < \frac{x}{2} < \frac{\pi}{2}$$

$\Rightarrow \frac{x}{2}$  lies in first quadrant.

$\Rightarrow \sin \frac{x}{2}, \cos \frac{x}{2}$  and  $\tan \frac{x}{2}$  are positive

$$\Rightarrow \cos \frac{x}{2} = \sqrt{\frac{1+\cos x}{2}} = \sqrt{\frac{1-3/5}{2}} = \frac{1}{\sqrt{5}}$$

$$\Rightarrow \sin \frac{x}{2} = \sqrt{\frac{1-\cos x}{2}} = \sqrt{\frac{1+3/5}{2}} = \frac{2}{\sqrt{5}} \text{ and}$$

$$\Rightarrow \tan \frac{x}{2} = \sqrt{\frac{1-\cos x}{1+\cos x}} = \sqrt{\frac{1+3/5}{1-3/5}} = 2$$

(ii) It is given that  $x$  lies in the III<sup>rd</sup> quadrant.

$$\therefore \pi < x < \frac{3\pi}{2}$$

$$\Rightarrow \frac{\pi}{2} < \frac{x}{2} < \frac{3\pi}{4}$$

$\Rightarrow \frac{x}{2}$  lies in II<sup>nd</sup> quadrant

$$\Rightarrow \cos \frac{x}{2} < 0, \sin \frac{x}{2} > 0 \text{ and } \tan \frac{x}{2} < 0$$

$$\Rightarrow \cos \frac{x}{2} = -\sqrt{\frac{1+\cos x}{2}}$$

$$\Rightarrow \cos \frac{x}{2} = -\sqrt{\frac{1-1/3}{2}} = -\frac{1}{\sqrt{3}}$$

$$\text{Also } \sin \frac{x}{2} = \sqrt{\frac{1-\cos x}{2}} \left[ \because \sin \frac{x}{2} > 0 \right]$$

$$\Rightarrow \sin \frac{x}{2} = \sqrt{\frac{1+1/3}{2}} = \sqrt{\frac{2}{3}} \left[ \because \cos x = -\frac{1}{3} \right]$$

$$\text{And } \tan \frac{x}{2} = \frac{\sin x/2}{\cos x/2} = \sqrt{\frac{2}{3}} \times -\sqrt{3} = -\sqrt{2}$$

(iii) It is given that  $x$  lies in IVth quadrant in which  $\cos x$  is positive.

$$\begin{aligned} \therefore \sin x = -\frac{1}{2} &\Rightarrow \cos x = \sqrt{1-\sin^2 x} \\ &= \sqrt{1-\frac{1}{4}} = \frac{\sqrt{3}}{2} \end{aligned}$$

Now,  $x$  lies in IV th quadrant

$$\Rightarrow \frac{3\pi}{2} < x < 2\pi \Rightarrow \frac{3\pi}{4} < \frac{x}{2} < \pi$$

$$\Rightarrow \frac{x}{2} \text{ lies in II nd quadrant.}$$

$$\Rightarrow \cos \frac{x}{2} < 0, \sin \frac{x}{2} > 0 \text{ and } \tan \frac{x}{2} < 0$$

$$\Rightarrow \cos \frac{x}{2} = -\sqrt{\frac{1+\cos x}{2}} \left[ \because \cos \frac{x}{2} < 0 \right]$$

$$\begin{aligned} \Rightarrow \cos \frac{x}{2} &= -\sqrt{\frac{1+\sqrt{3}/2}{2}} = -\frac{\sqrt{2+\sqrt{3}}}{2} \\ &\left[ \because \cos x = \frac{\sqrt{3}}{2} \right] \end{aligned}$$

$$\begin{aligned} \Rightarrow \sin \frac{x}{2} &= \sqrt{\frac{1-\cos x}{2}} \\ &\left[ \because \sin \frac{x}{2} > 0 \right] \end{aligned}$$

$$\begin{aligned} \Rightarrow \sin \frac{x}{2} &= \sqrt{\frac{1-\sqrt{3}/2}{2}} \Rightarrow \sin \frac{x}{2} = \frac{\sqrt{2-\sqrt{3}}}{2} \\ &\left[ \because \cos x = -\frac{1}{3} \right] \end{aligned}$$

$$\tan \frac{x}{2} = \frac{\sin(x/2)}{\cos(x/2)} = \frac{\sqrt{2-\sqrt{3}}}{2} \cdot \frac{-2}{\sqrt{2+\sqrt{3}}} = -\sqrt{\frac{2-\sqrt{3}}{2+\sqrt{3}}}$$

### Comprehension Type Questions

**A:** If in a triangle  $ABC$ ,  $\tan A + \tan B + \tan C = k$ . Also, given that  $ABC$  is an isosceles triangle with  $AC = AB$ . Also, on varying the values of ' $k$ ', the number of such possible triangles varies. On the basis of the information provided above, answer the questions that follow:

- 43.** The values of ' $k$ ' for which, there exists exactly one isosceles triangle  $ABC$  are given by  
 (a)  $k < 0$  or  $k = 3\sqrt{3}$   
 (b)  $[k \in (3\sqrt{3}, \infty)]$   
 (c)  $[k \in (0, 3\sqrt{3})]$   
 (d) No such value of  $k$  is possible.
- 44.** The values of ' $k$ ' for which there exist exactly two non-similar isosceles triangle  $ABC$  are given by  
 (a)  $k < 0$  or  $k = 3\sqrt{3}$   
 (b)  $k \in (3\sqrt{3}, \infty)$   
 (c)  $k \in (0, 3\sqrt{3})$   
 (d) No such value of  $k$  is possible.
- 45.** The values of ' $k$ ' for which there exist three non-similar isosceles triangles are given by  
 (a)  $k < 0$  or  $k = 3\sqrt{3}$   
 (b)  $[k \in (3\sqrt{3}, \infty)]$   
 (c)  $[k \in (0, 3\sqrt{3})]$   
 (d) No such value of  $k$  is possible.

**Solution:** 44. (a) 45. (b) 46. (d)

Let  $A = B$  then  $2A + C = 180^\circ$

$$\text{And } 2 \tan A + \tan C = k \quad \dots(1)$$

Now  $2A + C = 180^\circ \Rightarrow \tan 2A = -\tan C$

Also,  $2 \tan A + \tan C = k$

$$\Rightarrow 2 \tan A + (-\tan 2A) = k \Rightarrow 2 \tan A - \frac{2 \tan A}{1 - \tan^2 A} = k$$

$$\Rightarrow 2 \tan A (1 - \tan^2 A - 1) = k - k \tan^2 A \Rightarrow 2 \tan^3 A - k \tan^2 A + k = 0$$

Let  $\tan A = x$ ,  $x > 0$  (as  $A < 90^\circ$ ), then the equation becomes  $2x^3 - kx^2 + k = 0$ .

$$\text{Let } f(x) = 2x^3 - kx^2 + k = 0 \quad \dots(2)$$

$$\Rightarrow f(x) = 6x^2 - 2kx = 0 \Rightarrow x = \frac{k}{3}, 0$$

Also, note that  $f(0) = k$

Following cases arise:

- (i)  $k < 0$ , three graphs of cubic equation (2) are possible  $\because f(0) = k \Rightarrow f(0) < 0$

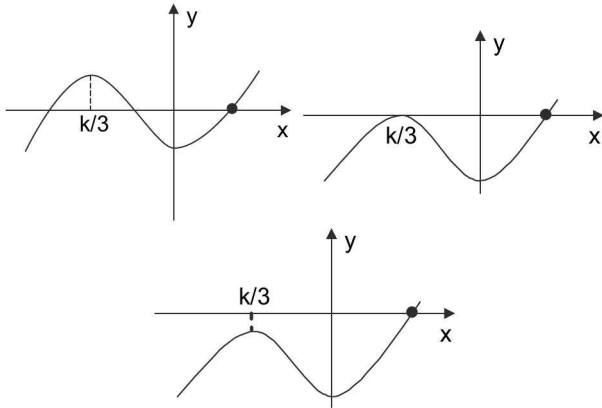

Clearly, in all these cases only one triangle is possible and the condition for that triangle to be possible is  $f(0) < 0 \Rightarrow k < 0$  so for  $k < 0$  only one isosceles triangle is possible.

(ii)  $k > 0$ , Three graphs of the cubic equation (2) are possible

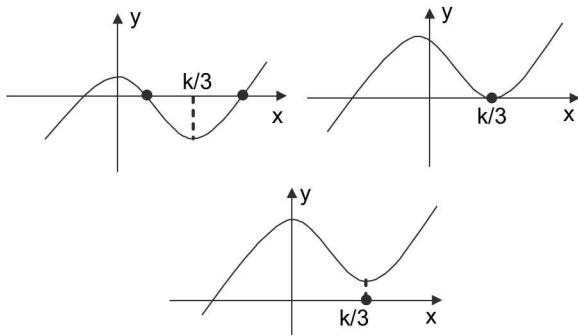

In figure 1, two such triangles are possible. The condition is  $f(k/3) < 0 \Rightarrow k \left(1 - \frac{k^2}{27}\right) < 0 \Rightarrow k > 3\sqrt{3}$

In figure 2, one such triangle is possible. The condition is  $f(k/3) = 0 \Rightarrow k = 3\sqrt{3}$

In figure 3, no such triangle is possible. The condition is  $f(k/3) > 0 \Rightarrow k < 3\sqrt{3}$

(iii)  $k = 0$ , graph will be as shown below, no such triangle is possible

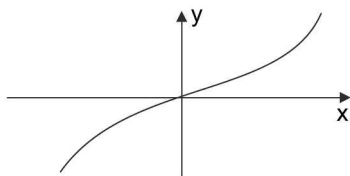

- ∴ (a) Either  $k < 0$  or  $k = 3\sqrt{3}$
- (b)  $k > 3\sqrt{3}$
- (c) Clearly, there will never exist three or more than three non-similar isosceles triangles for any value of  $k$ .

**B:** To solve trigonometric equations, it is necessary to know the basic trigonometric formulae such as

$$\tan(A \pm B) = \frac{\tan A \pm \tan B}{1 \mp \tan A \tan B},$$

$$\cot(A \pm B) = \frac{\cot A \cot B \mp 1}{\cot B \pm \cot A}, \quad \frac{1 - \cos A}{1 + \cos A} = \tan^2\left(\frac{A}{2}\right)$$

$$\frac{1 + \cos A}{\sin A} = \cot\left(\frac{A}{2}\right), \quad \frac{1 + \cos A}{1 - \cos A} = \cot^2\left(\frac{A}{2}\right)$$

$$1 + \cos 2A = 2 \cos^2 A \text{ etc.}$$

Using formulae like these, we can find out the values of a lot of trigonometric angles which are not standard values. Hence, using the information provided above, answer the questions that follows:

- 46. The value of  $\cot 7\frac{1^\circ}{2}$  is given by
  - (a)  $\sqrt{4+2\sqrt{2}} - (\sqrt{2}+1)$
  - (b)  $\sqrt{2} + \sqrt{3} + \sqrt{4} + \sqrt{6}$
  - (c)  $2 + \sqrt{-\sqrt{3}-\sqrt{6}}$
  - (d) None of these
- 47. The value of  $\tan 11\frac{1^\circ}{4}$  is given by
  - (a)  $\sqrt{4+2\sqrt{2}} - (\sqrt{2}+1)$
  - (b)  $\sqrt{2} + \sqrt{3} + \sqrt{4} + \sqrt{6}$
  - (c)  $2 + \sqrt{2} - \sqrt{3} - \sqrt{6}$
  - (d) None of these
- 48. The value of  $\tan 142\frac{1^\circ}{2}$  is given by
  - (a)  $\sqrt{4+2\sqrt{2}} - (\sqrt{2}+1)$
  - (b)  $\sqrt{2} + \sqrt{3} + \sqrt{4} + \sqrt{6}$
  - (c)  $2 + \sqrt{2} - \sqrt{3} - \sqrt{6}$
  - (d) None of these

**Solution:** 47. (b) 48. (a) 49. (c)

$$\begin{aligned} \text{(i) } \cot 7\frac{1^\circ}{2} &= \frac{\cos 7\frac{1^\circ}{2}}{\sin 7\frac{1^\circ}{2}} = \frac{2 \cos 7\frac{1^\circ}{2} \cos 7\frac{1^\circ}{2}}{2 \sin 7\frac{1^\circ}{2} \cos 7\frac{1^\circ}{2}} = \frac{2 \cos^2 7\frac{1^\circ}{2}}{2 \sin 7\frac{1^\circ}{2} \cos 7\frac{1^\circ}{2}} \\ &= \frac{1 + \cos 15^\circ}{\sin 15^\circ} = \frac{1 + \cos(45^\circ - 30^\circ)}{\sin(45^\circ - 30^\circ)} \\ &= \frac{1 + \frac{\sqrt{3}+1}{2\sqrt{2}}}{\frac{\sqrt{3}-1}{2\sqrt{2}}} = \frac{2\sqrt{2} + \sqrt{3} + 1}{\sqrt{3} - 1} \end{aligned}$$

$$= \frac{(2\sqrt{2} + \sqrt{3} + 1)(\sqrt{3} + 1)}{(\sqrt{3} - 1)(\sqrt{3} + 1)} = \frac{2\sqrt{6} + 2\sqrt{2} + 3 + \sqrt{3} + \sqrt{3} + 1}{3 - 1}$$

$$= \frac{2\sqrt{6} + 2\sqrt{2} + 2\sqrt{3} + 4}{2}$$

$$\sqrt{2} + \sqrt{3} + 2 + \sqrt{6} = \sqrt{2} + \sqrt{3} + \sqrt{4} + \sqrt{6}$$

$$(ii) \text{ LHS} = \tan 11\frac{1}{4}^\circ = \frac{\sin 11\frac{1}{4}^\circ}{\cos 11\frac{1}{4}^\circ} \times \frac{2\sin 11\frac{1}{4}^\circ}{2\sin 11\frac{1}{4}^\circ}$$

$$\Rightarrow \frac{2\sin^2 11\frac{1}{4}^\circ}{2\sin 11\frac{1}{4}^\circ \cos 11\frac{1}{4}^\circ} = \frac{1 - \cos 22\frac{1}{2}^\circ}{\sin 22\frac{1}{2}^\circ} = \frac{1 - \sqrt{\frac{1 + \cos 45^\circ}{2}}}{\sqrt{\frac{1 - \cos 45^\circ}{2}}}$$

$$= \frac{\sqrt{2} - \sqrt{1 + \cos 45^\circ}}{\sqrt{1 - \cos 45^\circ}} = \frac{\sqrt{2} - \sqrt{1 + \frac{1}{\sqrt{2}}}}{\sqrt{1 - \frac{1}{\sqrt{2}}}} = \frac{\sqrt{2} - \sqrt{\frac{\sqrt{2} + 1}{\sqrt{2}}}}{\sqrt{\frac{\sqrt{2} - 1}{\sqrt{2}}}}$$

$$\Rightarrow \frac{\sqrt{2\sqrt{2}} - \sqrt{\sqrt{2} + 1}}{\sqrt{\sqrt{2} - 1}} = \frac{\sqrt{2\sqrt{2}} - \sqrt{\sqrt{2} + 1}}{\sqrt{\sqrt{2} - 1}} \times \frac{\sqrt{\sqrt{2} + 1}}{\sqrt{\sqrt{2} + 1}}$$

$$= \frac{\sqrt{2\sqrt{2}} \cdot \sqrt{\sqrt{2} + 1} - \sqrt{(\sqrt{2} + 1)^2}}{\sqrt{\sqrt{2} + 1}(\sqrt{2} - 1)}$$

$$= \frac{\sqrt{2\sqrt{2}(\sqrt{2} + 1)} - (\sqrt{2} + 1)}{\sqrt{2} - 1}$$

$$= \sqrt{4 + 2\sqrt{2}} - (\sqrt{2} + 1)$$

$$(iii) \text{ LHS} = \tan\left(142\frac{1}{2}^\circ\right)$$

$$= \tan\left(90^\circ + 52\frac{1}{2}^\circ\right) = -\cot 52\frac{1}{2}^\circ = \frac{-1}{\tan\left(45^\circ + 7^\circ\right)}$$

$$= -\frac{1 - \tan 7\frac{1}{2}^\circ}{1 + \tan 7\frac{1}{2}^\circ} = -\frac{\cos 7\frac{1}{2}^\circ - \sin 7\frac{1}{2}^\circ}{\cos 7\frac{1}{2}^\circ + \sin 7\frac{1}{2}^\circ} =$$

$$-\frac{\left(\cos 7\frac{1}{2}^\circ - \sin 7\frac{1}{2}^\circ\right)^2}{\cos^2 7\frac{1}{2}^\circ - \sin^2 7\frac{1}{2}^\circ}$$

$$= -\frac{\left(1 - 2\sin 7\frac{1}{2}^\circ \cos 7\frac{1}{2}^\circ\right)}{\cos^2 7\frac{1}{2}^\circ - \sin^2 7\frac{1}{2}^\circ} = -\frac{\left(1 - \sin 15^\circ\right)}{\cos 15^\circ}$$

$$= -\frac{1 - \sin(45^\circ - 30^\circ)}{\cos(45^\circ - 30^\circ)}$$

$$= -\left(\frac{1 - \frac{\sqrt{3} - 1}{2\sqrt{2}}}{\frac{\sqrt{3} + 1}{2\sqrt{2}}}\right) = -\left(\frac{2\sqrt{2} - \sqrt{3} + 1}{\sqrt{3} + 1}\right)$$

$$= -\frac{(2\sqrt{2} - \sqrt{3} + 1)(\sqrt{3} - 1)}{(\sqrt{3} + 1)(\sqrt{3} - 1)}$$

$$= \frac{-(2\sqrt{2} - \sqrt{3} + 1)(\sqrt{3} - 1)}{3 - 1} = -\left[\frac{2\sqrt{2}(\sqrt{3} - 1) - (\sqrt{3} - 1)^2}{2}\right]$$

$$= -\frac{[2\sqrt{2}(\sqrt{3} - 1) - (3 + 1 - 2\sqrt{3})]}{2}$$

$$= -[\sqrt{2}(\sqrt{3} - 1) - (2 - \sqrt{3})]$$

$$= -\sqrt{6} + \sqrt{2} + 2 - \sqrt{3} = 2 + \sqrt{2} - \sqrt{3} - \sqrt{6}$$

## SECTION-III

### OBJECTIVE TYPE (ONLY ONE CORRECT ANSWER)

1. If  $(1 + \tan \alpha)(1 + \tan 4\alpha) = 2$ ,  $\alpha \in (0, \pi/16)$ , then  $\alpha$  is equal to

- (a)  $\pi/20$                       (b)  $\pi/30$   
 (c)  $\pi/40$                       (d)  $\pi/60$

2. If  $\theta = \frac{2\pi}{2009}$  then  $\cos \theta \cos 2\theta \cos 3\theta \dots \cos 1004\theta$  is equal to

- (a) 0                              (b)  $\frac{1}{2^{2008}}$   
 (c)  $\frac{1}{2^{1004}}$                       (d) None of these

3. If  $x = a \cos^2\theta \sin \theta$  and  $y = a \sin^2\theta \cos\theta$ , then  $(x^2 + y^2)^3$  is  
 (a)  $a^2x^2/y^2$  (b)  $a^2x^2y^2$   
 (c)  $a^2(x^2 - y^2)$  (d) None of these
4. The period of  $\frac{|\sin 4x| + |\cos 4x|}{|\sin 4x - \cos 4x| + |\sin 4x + \cos 4x|}$  is  
 (a)  $\pi/8$  (b)  $\pi/2$   
 (c)  $\pi/4$  (d)  $\pi$
5. In a triangle  $PQR$ ,  $\angle R = \pi/2$ . If  $\tan\left(\frac{P}{2}\right)$  and  $\tan\left(\frac{Q}{2}\right)$  are the roots of the equation  $ax^2 + bx + c = 0$ , ( $a \neq 0$ ), then  
 (a)  $a + b = c$  (b)  $b + c = a$   
 (c)  $a + c = b$  (d)  $b = c$
6. If  $\alpha$  and  $\beta$  are acute such that  $\tan(\alpha + \beta)$  and  $\tan(\alpha - \beta)$  satisfy the equation  $x^2 - 4x + 1 = 0$ , then  $(\alpha, \beta) =$   
 (a)  $(30^\circ, 60^\circ)$  (b)  $(45^\circ, 45^\circ)$   
 (c)  $(45^\circ, 30^\circ)$  (d)  $(60^\circ, 45^\circ)$
7.  $\frac{\sin^2 3A}{\sin^2 A} - \frac{\cos^2 3A}{\cos^2 A} =$   
 (a)  $\cos 2A$  (b)  $8 \cos 2A$   
 (c)  $\frac{1}{8} \cos 2A$  (d) None of these
8. The value of  $\sin^3 10^\circ + \sin^3 50^\circ - \sin^3 70^\circ$  is equal to  
 (a)  $-\frac{3}{2}$  (b)  $\frac{3}{4}$   
 (c)  $-\frac{3}{4}$  (d)  $-\frac{3}{8}$
9. If  $f(\theta) = (\sin \theta + \operatorname{cosec} \theta)^2 + (\cos \theta + \sec \theta)^2$  then minimum value of  $f(\theta)$  is  
 (a) 7 (b) 8  
 (c) 9 (d) None of these
10. A quadratic equation whose roots are  $\operatorname{cosec}^2\theta$  and  $\sec^2\theta$ , can be  
 (a)  $x^2 - 2x + 2 = 0$  (b)  $x^2 - 3x + 3 = 0$   
 (c)  $x^2 - 5x + 5 = 0$  (d) None of these
11. If  $\frac{\cos x}{a} = \frac{\sin x}{b}$  then  $|a \cos 2x + b \sin 2x|$  is equal to  
 (a)  $\sqrt{a^3 b}$  (b)  $\frac{a^2}{|b|}$   
 (c)  $\frac{b^2}{|a|}$  (d) None of these
12. If  $\tan^2 x + \sec x - a = 0$ , has at least one solution then, complete set of values of 'a' is  
 (a)  $(-\infty, 1]$  (b)  $(-\infty, 1]$   
 (c)  $[-1, 1]$  (d)  $[-1, \infty)$
13. If  $\sin^2\theta = \frac{x^2 + y^2 + 1}{2x}$ , then  $x$  must be  
 (a)  $-3$  (b)  $-2$   
 (c) 1 (d) None of these
14. If  $\sin\theta + \operatorname{cosec}\theta = 2$ , the value of  $\sin^{100}\theta + \operatorname{cosec}^{100}\theta$  is  
 (a) 2 (b)  $2^{10}$   
 (c)  $2^9$  (d) 10
15. If  $A = 130^\circ$  and  $x = \sin A + \cos A$ , then  
 (a)  $x > 0$  (b)  $x < 0$   
 (c)  $x = 0$  (d)  $x \geq 0$
16. If  $a = \pi/18$  rad, then  $\cos a + \cos 2a + \dots + \cos 18a$  is equal to  
 (a) 0 (b)  $-1$   
 (c) 1 (d)  $\pm 1$
17. In a right angled triangle, the hypotenuse is  $2\sqrt{2}$  times the length of perpendicular drawn from the opposite vertex on the hypotenuse, then the other two angles are  
 (a)  $\frac{\pi}{3}, \frac{\pi}{6}$  (b)  $\frac{\pi}{4}, \frac{\pi}{4}$   
 (c)  $\frac{\pi}{8}, \frac{3\pi}{8}$  (d)  $\frac{\pi}{12}, \frac{5\pi}{12}$
18. The expression  $(1 + \tan x + \tan^2 x)(1 - \cot x + \cot^2 x)$  has the positive values for  $x$ , given by  
 (a)  $0 \leq x \leq \frac{\pi}{2}$  (b)  $0 \leq x \leq \pi$   
 (c) for all  $x \in \mathbb{R}$  (d)  $x \geq 0$
19. If  $\sin x + \sin^2 x = 1$ , then  $\cos^{12}x + 3\cos^{10}x + 3\sin^8x + \cos^6x$  is equal to  
 (a) 1 (b) 2  
 (c) 3 (d) 0
20. If  $x = h + a \sec \theta$  and  $y = k + b \operatorname{cosec} \theta$ . Then,  
 (a)  $\frac{a^2}{(x+h)^2} - \frac{b^2}{(y+k)^2} = 1$   
 (b)  $\frac{a^2}{(x-h)^2} + \frac{b^2}{(y-k)^2} = 1$   
 (c)  $\frac{(x-h)^2}{a^2} + \frac{(y-k)^2}{b^2} = 1$   
 (d)  $x^2 + y^2 = a^2 + b^2$ .

21. If  $A+B+C=\pi$ , then 
$$\begin{vmatrix} \sin(A+B+C) & \sin B & \cos B \\ -\sin B & 0 & \tan A \\ \cos(A+C) & -\tan A & 0 \end{vmatrix} =$$

(a) 0 (b)  $-\infty$   
(c)  $\infty$  (d) 2

22. Consider the sequence (angles are measured in radians)  $\sin \log_{10} 2, \sin \log_{10} 3, \sin \log_{10} 4, \dots$ , then:
- (a) all the terms of this sequence are +ve  
(b) all the terms of this sequence are -ve  
(c) 1001<sup>th</sup> term is negative  
(d) 10001<sup>th</sup> term is negative

23. If  $\tan A, \tan B, \tan C$  are the roots of the cubic equation  $x^3 - 7x^2 + 11x - 7 = 0$  then  $A + B + C =$
- (a)  $\pi/2$  (b)  $\pi$   
(c)  $3\pi/2$  (d) None of these

24. If  $a_{n+1} = \sqrt{\frac{1}{2}(1+a_n)}$  then  $\cos\left(\frac{\sqrt{1-a_0^2}}{a_1 a_2 a_3 \dots \text{to } \infty}\right)$  is equal to
- (a) 1 (b) -1  
(c)  $a_0$  (d)  $1/a_0$

25. If  $a \sin x + b \cos(x+\theta) + b \cos(x-\theta) = d$  then the minimum value of  $|\cos\theta|$  is equal to

(a)  $\frac{1}{2|b|}\sqrt{d^2-a^2}$  (b)  $\frac{1}{2|a|}\sqrt{d^2-a^2}$   
(c)  $\frac{1}{2|d|}\sqrt{d^2-a^2}$  (d) None of these

26. If  $x \in (0, \pi)$  and  $(2 \cos x - 1)\left(\sin x - \frac{1}{2}\right)(\sin x - \cos x)\left(\cot x - \frac{1}{\sqrt{3}}\right) > 0$ , then complete set of values of  $x$  is

(a)  $x \in \left(\frac{\pi}{6}, \frac{\pi}{4}\right)$   
(b)  $x \in \left(\frac{\pi}{6}, \frac{\pi}{4}\right) \cup \left(\frac{\pi}{3}, \pi\right)$   
(c)  $x \in \left(0, \frac{\pi}{6}\right) \cup \left(\frac{\pi}{4}, \frac{\pi}{3}\right) \cup \left(\frac{\pi}{3}, \pi\right)$   
(d)  $x \in \left(0, \frac{\pi}{6}\right) \cup \left(\frac{\pi}{4}, \frac{\pi}{3}\right) \cup \left(\frac{\pi}{3}, \frac{5\pi}{6}\right)$

27. If  $0 < \alpha < \beta < \gamma < \frac{\pi}{2}$ , then  $\frac{\sin \alpha + \sin \beta + \sin \gamma}{\cos \alpha + \cos \beta + \cos \gamma}$  lies between
- (a)  $\sin \alpha$  and  $\sin \gamma$  (b)  $\tan \alpha$  and  $\tan \gamma$   
(c)  $\cos \alpha$  and  $\cos \gamma$  (d) none of these

28.  $\sin^2 A + \sin^2 B - \sin^2 C =$
- (a)  $2 \sin A \sin B \sin C$  (b)  $2 \cos A \cos B \cos C$   
(c)  $2 \cos A \sin B \sin C$  (d)  $2 \sin A \sin B \cos C$

29.  $\sin^2 \frac{A}{2} + \sin^2 \frac{B}{2} + \sin^2 \frac{C}{2} =$
- (a)  $1 - 2 \cos \frac{A}{2} \cos \frac{B}{2} \cos \frac{C}{2}$   
(b)  $1 - 2 \sin \frac{A}{2} \sin \frac{B}{2} \sin \frac{C}{2}$   
(c)  $1 + \cos \frac{A}{2} \cos \frac{B}{2} \cos \frac{C}{2}$   
(d)  $1 + \sin \frac{A}{2} \sin \frac{B}{2} \sin \frac{C}{2}$

30. Given that  $\tan A$  and  $\tan B$  are the roots of  $x^2 - px + q = 0$ , then the value of  $\sin^2(A+B)$  is

(a)  $\frac{p^2}{\{p^2 + (1-q)^2\}}$  (b)  $\frac{p^2}{(p^2 + q^2)}$   
(c)  $\frac{p^2}{\{p^2 - (1-q)^2\}}$  (d)  $\frac{p^2}{(p+q)^2}$

31. If the angle  $A$  of a triangle  $ABC$  is given by the equation  $5 \cos A + 3 = 0$ , then  $\sin A$  and  $\tan A$  are the roots of the equation

(a)  $15x^2 - 8x - 16 = 0$  (b)  $15x^2 - 8\sqrt{2}x + 16 = 0$   
(c)  $15x^2 - 8x + 16 = 0$  (d)  $15x^2 + 8x - 16 = 0$

32.  $\cos^2 \frac{A}{2} + \cos^2 \frac{B}{2} + \cos^2 \frac{C}{2} =$

(a)  $1 + 2 \sin \frac{A}{2} \sin \frac{B}{2} \sin \frac{C}{2}$   
(b)  $2 + 2 \sin \frac{A}{2} \sin \frac{B}{2} \sin \frac{C}{2}$   
(c)  $1 + 2 \cos \frac{A}{2} \cos \frac{B}{2} \cos \frac{C}{2}$   
(d)  $2 + 2 \cos \frac{A}{2} \cos \frac{B}{2} \cos \frac{C}{2}$

33.  $\sin^2(A/2) + \sin^2(B/2) - \sin^2(C/2) =$

(a)  $1 - 2 \cos \frac{A}{2} \cos \frac{B}{2} \sin \frac{C}{2}$   
(b)  $1 - 2 \cos \frac{B}{2} \cos \frac{C}{2} \sin \frac{A}{2}$   
(c)  $1 - 2 \cos \frac{C}{2} \cos \frac{A}{2} \sin \frac{B}{2}$   
(d) None of these



1.88 > Trigonometry

34. If  $\sin A - \sqrt{6} \cos A = \sqrt{7} \cos A$ , then  $\cos A + \sqrt{6} \sin A$  is equal to  
 (a)  $\sqrt{6} \sin A$  (b)  $\sqrt{7} \sin A$   
 (c)  $\sqrt{6} \cos A$  (d)  $\sqrt{7} \cos A$
35.  $A, B, C$  are the angles of a triangle, then  $\sin^2 A + \sin^2 B + \sin^2 C - 2 \cos A \cos B \cos C =$   
 (a) 1 (b) 2  
 (c) 3 (d) 4
36. If  $\frac{3\pi}{4} < a < \pi$ , then  $\sqrt{\operatorname{cosec}^2 \alpha + 2 \cot \alpha} =$   
 (a)  $1 + \cot \alpha$  (b)  $1 - \cot \alpha$   
 (c)  $-1 - \cot \alpha$  (d)  $-1 + \cot \alpha$
37. If  $\cos A = \cos B \cos C$  and  $A + B + C = \pi$ , then the value of  $\cot B \cot C$  is  
 (a) 1 (b) 2  
 (c)  $1/3$  (d)  $1/2$
38. If  $x = X \cos \theta - Y \sin \theta$ ,  $y = X \sin \theta + Y \cos \theta$  and  $x^2 + 4xy + y^2 = AX^2 + BY^2$ ,  $0 \leq \theta \leq \pi/2$ , then  
 (a)  $\theta = \pi/6, A = 4$  (b)  $\theta = \pi/4, A = 3$   
 (c)  $A = 3, \pi = \pi/3$  (d) None of these
39. If  $0 < x < \pi/2$  and  $\sin^n x + \cos^n x \geq 1$ ,  $n \in \mathbb{R}$ , then  
 (a)  $2 \leq n \leq \infty$  (b)  $-\infty < n \leq 2$   
 (c)  $-1 \leq n \leq 2$  (d) None of these
40. The side of a triangle, inscribed in a given circle subtend angles  $\alpha, \beta, \gamma$  at the centre. The minimum value of the A.M. of  $\cos(\alpha + \pi/2)$ ,  $\cos(\beta + \pi/2)$  and  $\cos(\gamma + \pi/2)$  is:  
 (a)  $\frac{\sqrt{3}}{2}$  (b)  $-\frac{\sqrt{3}}{2}$   
 (c)  $\frac{\sqrt[3]{3}}{2}$  (d)  $-\frac{\sqrt[3]{3}}{2}$
41. If  $x + 1/x = 2 \cos \alpha$ ,  $y + 1/y = 2 \cos \beta$ ,  $z + 1/z = 2 \cos \gamma$  and  $x + y + z = xyz$ , then find the value of  $\cos(\alpha - \beta) + \cos(\beta - \gamma) + \cos(\gamma - \alpha)$ .  
 (a) 1 (b) 2  
 (c) -1 (d) None of these
42. If  $\alpha, \beta$  are two of the solutions of the equation  $p \sin 2\theta + (q - 1) \cos 2\theta + q + 1 = 0$ , then find the value of  $\sin^2(\alpha + \beta) + p \sin(\alpha + \beta) \cos(\alpha + \beta) + q \cos^2(\alpha + \beta)$ .  
 (a)  $p$  (b)  $q$   
 (c)  $p/q$  (d) None of these
43. If the sum of the series  $\operatorname{cosec} \theta + \operatorname{cosec} 2\theta + \operatorname{cosec} 4\theta + \dots$  to  $n$  terms is given by  $\cot \frac{\theta}{2} - \cot(2^n \theta)$  find the value of  $k$  in the terms of  $n$ .  
 (a)  $n - 1$  (b)  $n$   
 (c)  $n - 2$  (d) None of these
44. Given the product  $p$  of sines of the angles of a  $\Delta$  and the product  $q$  of their cosines, find the cubic equation, whose coefficients are functions of  $p$  and  $q$  and whose roots are the tangents of the triangles of the  $\Delta$ .  
 (a)  $qx^3 - px^2 + (1 + q)x - p = 0$   
 (b)  $qx^3 - qx^2 + (1 + p)x - p = 0$   
 (c)  $px^3 - px^2 + (1 + q)x - q = 0$   
 (d) None of these
45. If  $A, B, C$  are angles of triangle, then  $2 \sin A/2 \operatorname{cosec} B/2 \sin C/2 - \sin A \cot B/2 - \cos A$   
 (a) independent of  $A, B, C$   
 (b) function of  $A, B$   
 (c) function of  $C$   
 (d) None of these
46. The least value of  $6 \tan^2 \phi + 54 \cot^2 \phi + 18$  is  
 I. 54 when A.M.  $\geq$  G.M. is applicable for  $6 \tan^2 \phi, 54 \cot^2 \phi, 18$ .  
 II. 54 when A.M.  $\geq$  G.M is applicable for  $6 \tan^2 \phi, 54 \cot^2 \phi$  and 18 is added further.  
 III. 78 when  $\tan^2 \phi = \cot^2 \phi$ .  
 (a) I is correct  
 (b) I and II are correct  
 (c) III is correct  
 (d) None of the above are correct
47. The difference between the greatest and least values of the function  $f(x) = \cos x + 1/2 \cos 2x - \frac{1}{3} \cos 3x$  is  
 (a)  $2/3$  (b)  $8/7$   
 (c)  $9/4$  (d)  $3/8$
48. If  $A, B, C$  be the angles of a triangle, then  $\sum \frac{\cot A + \cot B}{\tan A + \tan B} =$   
 (a) 1 (b) -1  
 (c) 0 (d) None of these
49. If  $\sum xy = 1$ , then  $\sum \frac{x+y}{1-xy} =$   
 (a)  $\frac{1}{xyz}$  (b)  $\frac{4}{xyz}$   
 (c)  $XYZ$  (d) None of these

50. Let  $\theta \in \left(0, \frac{\pi}{4}\right)$  and  $t_1 = (\tan \theta)^{\tan \theta}$ ,  $t_2 = (\tan \theta)^{\cot \theta}$ ,  $t_3 = (\cot \theta)^{\tan \theta}$  and  $t_4 = (\cot \theta)^{\cot \theta}$ , then
- (a)  $t_1 > t_2 > t_3 > t_4$       (b)  $t_4 > t_3 > t_1 > t_2$   
 (c)  $t_3 > t_1 > t_2 > t_4$       (d)  $t_2 > t_3 > t_1 > t_4$

51. Let  $\theta \in \left(0, \frac{\pi}{2}\right)$  and  $t_1 = (\sin \theta)^{\operatorname{cosec} \theta}$ ,  $t_2 = (\operatorname{cosec} \theta)^{\sin \theta}$ ,  $t_3 = (\sin \theta)^{\sin \theta}$  and  $t_4 = (\operatorname{cosec} \theta)^{\operatorname{cosec} \theta}$ , then
- (a)  $t_3 > t_2 > t_4 > t_1$       (b)  $t_4 > t_2 > t_3 > t_1$   
 (c)  $t_4 > t_3 > t_2 > t_1$       (d)  $t_4 > t_1 > t_3 > t_2$

52. Let  $\theta \in \left(0, \frac{\pi}{4}\right)$  and  $t_1 = (\sin \theta)^{\cos \theta}$ ,  $t_2 = (\cos \theta)^{\cos \theta}$ ,  $t_3 = (\sin \theta)^{\sin \theta}$  and  $t_4 = (\cos \theta)^{\sin \theta}$ , then
- (a)  $t_3 > t_1 > t_4 > t_2$       (b)  $t_4 > t_3 > t_2 > t_1$   
 (c)  $t_4 > t_2 > t_3 > t_1$       (d) Can not be determined

53. Ram, Shyam and Ganesh run on the tracks made in the shape of a star, pentagon and circle, respectively. The radius of the circle is 'r' and side of the pentagon = 2a and  $OX = OL = 2b$ . O is the centre of the figure.

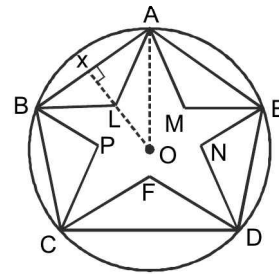

If  $a + b = r = 10$  km and Ram travels at a speed of 10 kmph then the time taken by Ram to complete one round is

- (a) 6.52 hours      (b) 8.5 hours  
 (c) 8 hours      (d) 7.21 hours

## SECTION-IV

### OBJECTIVE TYPE (MORE THAN ONE CORRECT ANSWERS)

- $\pi$  is the fundamental period of
  - $\frac{1 + \sin x}{\cos x (1 + \operatorname{cosec} x)}$
  - $|\sin x| + |\cos x|$
  - $\sin 2x + \cos 2x$
  - $\cos(\sin x) + \cos(\cos x)$
- If  $\left(\cos^2 x + \frac{1}{\cos^2 x}\right)(1 + \tan^2 2y)(3 + \sin 3z) = 4$ , then
  - x may be a multiple of  $\pi$
  - x can not be an even multiple of  $\pi$
  - z can be a multiple of  $\pi$
  - y can be a multiple of  $\pi/2$
- $\frac{\cos^4 A}{\cos^2 B} + \frac{\sin^4 A}{\sin^2 B} = 1$ , then
  - $\sin^4 A + \sin^4 B = 2 \sin^2 A \sin^2 B$
  - $\frac{\cos^4 B}{\cos^2 A} + \frac{\sin^4 B}{\sin^2 A} = 1$
  - $\frac{\cos^4 B}{\cos^2 A} - \frac{\sin^4 B}{\sin^2 A} = 1$
  - $\frac{\cos^{2n+2} B}{\cos^{2n} A} + \frac{\sin^{2n+2} B}{\sin^{2n} A} = 1$ , when  $\in N$
- If  $\tan x/2 = \operatorname{cosec} x - \sin x$ , then  $\tan^2 x/2$  is
  - $2 - \sqrt{5}$
  - $\sqrt{5} - 2$
  - $(9 - 4\sqrt{5})(2 + \sqrt{5})$
  - $(9 + 4\sqrt{5})(2 - \sqrt{5})$
- If  $a > b > 0$ ,  $y = a \operatorname{cosec} \theta - b \cot \theta$ , then for  $0 < \theta < \pi$ 
  - $\min y = \sqrt{a^2 + b^2}$
  - $\min y = \sqrt{a^2 - b^2}$
  - y can not become  $(a - b)$  for any  $\theta$
  - y can not become 0 for any  $\theta$
- If  $\tan x = \frac{2b}{a - c}$ ,  $y = a \cos^2 x + 2b \sin x \cos x + c \sin^2 x$ ,  $z = a \sin^2 x - 2b \sin x \cos x + c \cos^2 x$ , then
  - $y = z$
  - $y + z = a + c$
  - $y - z = a - c$
  - $y - z = (a - c)^2 + 4b^2$
- If  $\sin \theta = \sin \alpha$ , then  $\sin \frac{\theta}{3}$  is equal to
  - $\sin \frac{\alpha}{3}$
  - $\sin \left(\frac{\pi}{3} - \frac{\alpha}{3}\right)$
  - $\sin \left(\frac{\pi}{3} + \frac{\alpha}{3}\right)$
  - $-\sin \left(\frac{\pi}{3} + \frac{\alpha}{3}\right)$

8. All values of  $x \in \left(0, \frac{\pi}{2}\right)$  such that  $\frac{\sqrt{3}-1}{\sin x} + \frac{\sqrt{3}+1}{\cos x} = 4\sqrt{2}$  are

- (a)  $\pi/15$  (b)  $\pi/12$   
 (c)  $11\pi/36$  (d)  $3\pi/10$

9. Let  $P_n(x)$  be a polynomial in  $x$  of degree  $n$ . Then for every positive integer  $n$ ,  $\sin 2nx$  is expressible as:

- (a)  $P_{2n}(\sin x)$  (b)  $P_{2n}(\cos x)$   
 (c)  $\sin x P_{2n-1}(\cos x)$  (d)  $\cos x P_{2n-1}(\sin x)$

10. If  $y = \frac{\sqrt{1-\sin 4x} + 1}{\sqrt{1+\sin 4x} - 1}$  then one of the values of  $y$  is

- (a)  $\cot x$  (b)  $-\tan x$   
 (c)  $-\cot\left(\frac{\pi}{4} + x\right)$  (d)  $\tan\left(\frac{\pi}{4} + x\right)$

11. Which of the following statement(s) is/are correct?

- (a)  $\sum_{r=1}^7 \tan^2 \frac{r\pi}{16} = \sum_{r=1}^7 \cot^2 \frac{r\pi}{16} = 35$   
 (b)  $\sum_{r=1}^{10} \cos^3 \frac{r\pi}{3} = -\frac{9}{8}$   
 (c)  $\sum_{r=1}^3 \tan^2\left(\frac{2r-1}{7}\right) = \sum_{r=1}^3 \cot^2\left(\frac{2r-1}{7}\right)$   
 (d)  $\sum_{r=1}^3 \tan^2\left(\frac{2r-1}{7}\right) \cdot \sum_{r=1}^3 \cot^2\left(\frac{2r-1}{7}\right) = 105$

## SECTION-V

### COMPREHENSION TYPE QUESTIONS

**A:** To solve or prove trigonometric inequalities it is necessary to practice periodicity, monotonicity and other properties of trigonometric function. Making use of certain concepts of calculus and graphical representation, the process of solving a problem becomes easy and time saving. Following concepts are particularly very useful while solving problems on trigonometric inequality.

#### Deduction-1

- (a) If  $f(x)$  is continuous and monotonically increasing function i.e.,  $f'(x) > 0$  then  $\forall x_1 > x_2$   
 $\Rightarrow f(x_1) > f(x_2)$   
 (b) If  $f(x)$  is continuous and decreasing function and  $f'(x) < 0$  then  $\forall x_1 > x_2$   
 $\Rightarrow f(x_1) < f(x_2)$

#### Deduction-2

If  $f'(x) > 0$  and  $f''(x) < 0$  for all  $x \in D_f$  then the graph of  $f(x)$  increases with increasing rate and remain concave downward

( $\because f''(x) < 0$ ). Therefore chord of the curve lies below the curve. Considering a point  $B$  dividing chord  $PQ$  in the ratio

$n: m$ , we get  $f\left(\frac{mx_1 + nx_2}{m+n}\right) > \frac{mf(x_1) + nf(x_2)}{m+n}$

( $\because$  AM > BM)

#### Deduction-3

If  $f'(x) > 0$  and  $f''(x) = 0$  for all  $x \in D_f$  i.e., graph of  $f(x)$  increases and remains concave up ( $\because f''(x) > 0$ ). Therefore chord of the curve lies above the curve. Considering a point  $B$  dividing chord  $PQ$  in the ratio  $n: m$ , we get

$$f\left(\frac{mx_1 + nx_2}{m+n}\right) < \frac{mf(x_1) + nf(x_2)}{m+n} \quad (\text{AM} < \text{BM}).$$

While proving an inequality, we may also use the following concepts of inequality of means (AM  $\geq$  GM  $\geq$  HM) and inequality of weighted means wherever applicable.

#### Deduction 4

If  $A(x_1, f(x_1))$ ,  $B(x_2, f(x_2))$ ,  $C(x_3, f(x_3))$  are three points on a curve  $y = f(x)$ , such that  $f''(x) < 0$ , then

$$f\left(\frac{x_1 + x_2 + x_3}{3}\right) \geq \frac{f(x_1) + f(x_2) + f(x_3)}{3} \quad \text{and if } f''(x) > 0,$$

$$\text{then } f\left(\frac{x_1 + x_2 + x_3}{3}\right) \leq \frac{f(x_1) + f(x_2) + f(x_3)}{3}$$

1. If  $\theta$  and  $\phi$  are two distinct angles both acute then which of the following is true?

- (a)  $\theta - \phi \geq \sin \theta - \sin \phi$   
 (b)  $\theta - \phi < \sin \theta - \sin \phi$   
 (c)  $\theta - \cos \theta < \phi - \cos \phi$   
 (d) None of these

2.  $A, B, C \in \left(-\frac{\pi}{2}, \frac{\pi}{2}\right)$  then which of the following is true?

- (a)  $\cos A + \cos B + \cos C \geq \frac{3}{2}$   
 (b)  $\cos \frac{A}{2} + \cos \frac{B}{2} + \cos \frac{C}{2} \leq \frac{3\sqrt{3}}{2}$   
 (c)  $\sin \frac{A}{2} + \sin \frac{B}{2} + \sin \frac{C}{2} \leq \frac{1}{8}$   
 (d) None of these

3. If  $A + B + C = \pi$  and  $A, B, C$  are acute angles then which of the following is true?

- (a)  $\cos A \cos B \cos C \leq \frac{1}{8}$   
 (b)  $\sin A + \sin B + \sin C > 2$   
 (c)  $\sin A + \sin B + \sin C \leq \frac{3\sqrt{3}}{2}$   
 (d)  $\tan^2 \frac{A}{2} + \tan^2 \frac{B}{2} + \tan^2 \frac{C}{2} > 1$

4. For angles  $A, B, C$  of an acute angled triangle. Check which of these is true?

- (a)  $\cos\left(\frac{\pi}{4} + \frac{A}{2}\right) + \cos\left(\frac{\pi}{4} + \frac{B}{2}\right) + \cos\left(\frac{\pi}{4} + \frac{C}{2}\right) \leq \frac{3}{2}$   
 (b)  $\sec^2\left(\frac{\pi}{6} + \frac{A}{4}\right) + \sec^2\left(\frac{\pi}{4} + \frac{B}{4}\right) + \sec^2\left(\frac{\pi}{3} + \frac{C}{4}\right) < 3$   
 (c)  $\sec^2\left(\frac{\pi}{6} + \frac{A}{4}\right) + \sec^2\left(\frac{\pi}{4} + \frac{B}{4}\right) + \sec^2\left(\frac{\pi}{3} + \frac{C}{4}\right) > 3$   
 (d)  $\cos\left(\frac{\pi}{4} + \frac{A}{2}\right) + \cos\left(\frac{\pi}{4} + \frac{B}{2}\right) + \cos\left(\frac{\pi}{4} + \frac{C}{2}\right) \geq \frac{3}{2}$

B: In a  $\triangle ABC$ , if  $\cos A \cos B \cos C = \frac{\sqrt{3}-1}{8}$  and  $\sin A \sin B \sin C = \frac{3+\sqrt{3}}{8}$ , then

5. The value of  $\tan A + \tan B + \tan C$  is

- (a)  $\frac{3+\sqrt{3}}{\sqrt{3}-1}$                       (b)  $\frac{\sqrt{3}+4}{\sqrt{3}-1}$   
 (c)  $\frac{6-\sqrt{3}}{\sqrt{3}-1}$                       (d)  $\frac{\sqrt{3}+\sqrt{2}}{\sqrt{3}-1}$

6. The value of  $\tan A \tan B + \tan B \tan C + \tan C \tan A$  is

- (a)  $5 - 4\sqrt{3}$                       (b)  $5 + 4\sqrt{3}$   
 (c)  $6 + \sqrt{3}$                       (d)  $6 - \sqrt{3}$

7. The value of  $\tan A, \tan B$  and  $\tan C$  are

- (a)  $1, \sqrt{3}, \sqrt{2}$                       (b)  $1, \sqrt{3}, 2$   
 (c)  $1, 2, \sqrt{3}$                       (d)  $1, \sqrt{3}, 2 + \sqrt{3}$

C: In a triangle  $ABC$ ,  $\cot A + \cot B + \cot C = \cot \theta$ .

8. The possible value of  $\theta$  is

- (a)  $15^\circ$                       (b)  $35^\circ$   
 (c)  $45^\circ$                       (d) None of these

9.  $\frac{\sin A \sin B \sin C}{1 + \cos A \cos B \cos C} =$

- (a)  $\tan^2 \theta$                       (b)  $\cot^2 \theta$   
 (c)  $\cot \theta$                       (d)  $\tan \theta$

10.  $\sin(A - \theta) \sin(B - \theta) \sin(C - \theta) =$

- (a)  $\tan^3 \theta$                       (b)  $\cot^3 \theta$   
 (c)  $\sin^3 \theta$                       (d)  $\cos^3 \theta$

D: We are familiar with elementary conditional identities in a triangle. We know that  $A + B + C = 180^\circ$  in a triangle. General conditional identities can be derived by taking sine, cosine or tangent of both side or taking sine, cosines or tangents after transposing one angle to the other side. We may also divide by 2 and follow the same steps.

11. In any triangle  $\tan A \tan B + \tan B \tan C + \tan C \tan A$  must be equal to -

- (a) 9  
 (b)  $\operatorname{cosec} \frac{A}{2} \operatorname{cosec} \frac{B}{2} \operatorname{cosec} \frac{C}{2} + 1$   
 (c)  $\sec A \sec B \sec C + 1$   
 (d) None of these

12. In any triangle  $\cot A \cot B \cot C + \operatorname{cosec} A \operatorname{cosec} B \operatorname{cosec} C$  must be equal to

- (a)  $\frac{1}{\sqrt{3}}$   
 (b)  $\tan A + \tan B + \tan C$   
 (c)  $\cot A + \cot B + \cot C$   
 (d) None of these

13. In any triangle  $(\cot B + \cot C)(\cot C + \cot A)(\cot A + \cot B)$  must be equal to:

- (a)  $\frac{8}{3\sqrt{3}}$   
 (b)  $\frac{8}{27} \tan A \tan B \tan C$   
 (c)  $\operatorname{cosec} A \operatorname{cosec} B \operatorname{cosec} C$   
 (d) None of these

1.92 > Trigonometry

14. O is a point inside  $\triangle ABC$  such that

$$\angle OAB = \angle OBC = \angle OCA = \omega$$

then  $\cot \omega$  must be equal to:

- (a)  $\cot A \cot B \cot C$
- (b)  $\cot A + \cot B + \cot C$
- (c)  $\operatorname{cosec}^2 A + \operatorname{cosec}^2 B + \operatorname{cosec}^2 C$
- (d) None of these

E: Given that  $\cos 2^m \theta \cos 2^{m+1} \theta \dots \cos 2^n \theta$

$$= \frac{\sin 2^{n+1} \theta}{2^{n-m+1} \sin 2^m \theta} \text{ where } 2^m \theta \neq k\pi, m, n, k \in \mathbb{Z}.$$

15.  $\sin \frac{9\pi}{14} \sin \frac{11\pi}{14} \sin \frac{13\pi}{14}$  equals

- (a)  $\frac{1}{64}$
- (b)  $-\frac{1}{64}$
- (c)  $\frac{1}{8}$
- (d)  $-\frac{1}{8}$

16.  $\cos 2^3 \frac{\pi}{10} \cdot \cos 2^4 \frac{\pi}{10} \cdot \cos 2^5 \frac{\pi}{10} \dots \cos 2^{10} \frac{\pi}{10}$  equals

- (a)  $\frac{1}{128}$
- (b)  $\frac{1}{256}$
- (c)  $\frac{1}{512}$
- (d) None of these

17.  $\cos \frac{\pi}{11} \cos \frac{2\pi}{11} \cos \frac{3\pi}{11} \dots \cos \frac{11\pi}{11}$  equals

- (a)  $\frac{1}{32}$
- (b)  $\frac{1}{512}$
- (c)  $\frac{1}{1024}$
- (d) None of these

F:  $\alpha$  is a root of the equation

$$(2 \sin x - \cos x)(1 + \cos x) = \sin^2 x$$

$\beta$  is a root of the equation

$$3 \cos^2 x - 10 \cos x + 3 = 0 \text{ and}$$

$\gamma$  is a root of the equation

$$1 - \sin 2x = \cos x - \sin x, 0 \leq \alpha, \beta, \gamma \leq \pi/2$$

18.  $\cos \alpha + \cos \beta + \cos \gamma$  can be equal to -

- (a)  $\frac{3\sqrt{6} + 2\sqrt{2} + 6}{6\sqrt{2}}$
- (b)  $-\left(\frac{3\sqrt{3} + 8}{6}\right)$
- (c)  $\frac{3\sqrt{3} + 2}{6}$
- (d) None of these

19.  $\sin \alpha + \sin \beta + \sin \gamma$  can be equal to -

- (a)  $-\left(\frac{14 + 3\sqrt{2}}{6\sqrt{2}}\right)$
- (b)  $5/6$
- (c)  $\frac{3 + 4\sqrt{2}}{6}$
- (d)  $\frac{1 + \sqrt{2}}{2}$

20.  $\sin(\alpha - \beta)$  is equal to -

- (a) 1
- (b) 0
- (c)  $\frac{1 - 2\sqrt{6}}{6}$
- (d)  $\frac{\sqrt{3} - 2\sqrt{2}}{6}$

## SECTION-VI

### MATCH THE COLUMN TYPE QUESTIONS

1. Column-I

- (i) The expression  $\cos^2(A - B) + \cos^2 B - 2 \cos(A - B) \cos A \cos B$  is
- (ii) If  $a = \cos A \cos B + \sin A \sin B \cos C$ ,  $b = \cos A \sin B - \sin A \cos B \cos C$  and  $c = \sin A \sin C$ , then  $a^2 + b^2 + c^2$  is
- (iii) If  $\tan a$  and  $\tan b$  are the roots of  $x^2 + Ax + B = 0$ , then  $\sin(a + b)$  is
- (iv) If  $\frac{\tan(A + B - C)}{\tan(A + C - B)} = \frac{\tan C}{\tan B}$  and  $B + C, B - C \neq n\pi, n \in \mathbb{Z}$ ,  $\sin C + \cos C + \tan C$  is

### Column-II

- (a) independent of A
  - (b) independent of B
  - (c) independent of C
  - (d) a constant
2. Column-I
- (i) If  $x \sin^3 a + y \cos^3 a = \sin a \cos a$  and  $x \sin a = y \cos a$ , then  $x^2 + y^2$  is equal to
  - (ii) If  $x \sin \theta = y \sin \left(\theta + \frac{2\pi}{3}\right) = z \sin \left(\theta + \frac{4\pi}{3}\right)$  then  $4 + \Sigma xy$  is equal to
  - (iii) Let  $A = \sin^8 \theta + \cos^{14} \theta$ , then maximum value of A is

- (iv) If  $\sin x + \sin y = 3(\cos y - \cos x)$ , then the value of  $\sin 3x + \sin 3y$  can be

**Column-II**

- (a) -1  
 (b) 1  
 (c) 0  
 (d) 4

**3. Column-I**

- (i)  $(a + 2) \sin a + (2a - 1) \cos a = 2a + 1$  if  $\tan a$  is equal to; ( $\tan a/2 \neq 1/a$ )  
 (ii) If  $\operatorname{cosec} \theta = 3 + 1/12$ , then value of  $\frac{\operatorname{cosec} \theta + \cot \theta}{8}$  is  
 (iii) The value of  $\sin^2 \frac{\pi}{18} + \sin^2 \frac{\pi}{9} + \sin^2 \frac{7\pi}{18} + \sin^2 \frac{4\pi}{9}$  is equal to  
 (iv) If  $\theta = \frac{\pi}{4n}$  then  $\tan \theta \tan 2\theta \tan 3\theta \dots \tan (2n-2)\theta \tan (2n-1)\theta$  is equal to

**Column-II**

- (a) 2  
 (b) 3/4  
 (c) 1  
 (d) 4/3

**4. Column-I**

- (i) The maximum value of  $\{\cos (2\alpha + \theta) + \cos (2\beta + \theta)\}$ , where  $\alpha, \beta$  are constants, is  
 (ii) The maximum value of  $\{\cos 2\alpha + \cos 2\beta\}$ , where  $(\alpha + \beta)$  is constant and  $\alpha, \beta \in (0, \pi/2)$ , is  
 (iii) The minimum value of  $\{\sec 2\alpha + \sec 2\beta\}$ , where  $(\alpha + \beta)$  is constant and  $\alpha, \beta \in (0, \pi/4)$ , is  
 (iv) The minimum value of  $\sqrt{\{\tan \theta + \cot \theta - 2 \cos 2(\alpha + \beta)\}}$ , where  $\alpha, \beta$  are constants and  $\theta \in (0, \pi/2)$ , is  
 (a)  $2 \sin (\alpha + \beta)$   
 (b)  $2 \sec (\alpha + \beta)$   
 (c)  $2 \cos (\alpha + \beta)$   
 (d)  $2 \cos (\alpha - \beta)$

## SECTION-VII

**ASSERTION AND REASONING REASON TYPE QUESTIONS**

The questions given below consist of an assertion (A) and the reason (R). Use the following key to choose the appropriate answer.

- (a) If both assertion and reason are correct and reason is the correct explanation of the assertion.  
 (b) If both assertion and reason are correct but reason is not correct explanation of the assertion.  
 (c) If assertion is correct, but reason is incorrect  
 (d) If assertion is incorrect, but reason is correct

Now consider the following statements:

- 1. A.** If  $A + B + C = \pi$ , then the minimum value of  $\prod \tan A$  is  $3\sqrt{3}$ .  
**R.**  $AM \geq GM$   
**2. A.** If  $a, b, c \in \mathbb{R}^+$  and not all equal, then  $\sec \theta = \frac{(bc + ca + ab)}{(a^2 + b^2 + c^2)}$ .  
**R.**  $\sec \theta \leq -1$  and  $\sec \theta \geq 1$

**3. A.**  $\cos^3 \alpha + \cos^3 \left( \alpha + \frac{2\pi}{3} \right) + \cos^3 \left( \alpha + \frac{4\pi}{3} \right) = 3 \cos \alpha \cos \left( \alpha + \frac{2\pi}{3} \right) \cos \left( \alpha + \frac{4\pi}{3} \right)$ .

**R.** If  $a + b + c = 0 \Leftrightarrow a^3 + b^3 + c^3 = 3abc$

**4. A.**  $\sin 2 > \sin 3$

**R.** If  $x, y \in \left( \frac{\pi}{2}, \pi \right)$ ,  $x < y$ , then  $\sin x > \sin y$

**5. A.** If  $\cos (\beta - \gamma) + \cos (\gamma - \alpha) + \cos (\alpha - \beta) = -\frac{3}{2}$ , then  $\cos \alpha + \cos \beta + \cos \gamma = \sin \alpha + \sin \beta + \sin \gamma = 0$

**R.**  $a^2 + b^2 = 0 \Rightarrow a + b = 0$

**6. A.** Sum up to  $n$  terms, the series  $\tan a \tan(a + b) + \tan(a + b) \tan(a + 2b) + \tan(a + 2b) \tan(a + 3b) + \dots$  is given by  $\frac{\tan(\alpha + n\beta)(\tan \alpha - n \tan \beta)}{\tan \beta}$ .

**R.**  $\tan \beta = \frac{\tan(\alpha + r\beta) - \tan(\alpha + (r-1)\beta)}{1 + \tan(\alpha + r\beta) \tan(\alpha + (r-1)\beta)}$

1.94 > Trigonometry

7. A. The number of solutions of the equation

$$\sqrt{17 \sec^2 x + 16 \left[ \frac{1}{2} \tan x \sec x - 1 \right]} = 2$$

$\tan x (1 + 4 \sin x)$  is  $2 \forall x \in [0, \pi]$ .

R.  $|x| = x; \forall x \in \mathbb{R}^+$

8. A. There are only 2 possible solutions for the ordered triplet  $(\tan x, \tan y, \tan z)$  which satisfies the equation  $\frac{\tan x}{1} = \frac{\tan y}{2} = \frac{\tan z}{3} (\neq 0)$  where  $x + y + z = \pi$ .

R. For the angles  $A, B, C$  of a triangle,  $\tan(A + B + C) = \frac{\tan A + \tan B + \tan C - \tan A \tan B \tan C}{1 - \tan A \tan B - \tan B \tan C - \tan C \tan A}$

9. A. There is exactly one possible solution for  $(x, y)$  that satisfy the equation:

$$\tan^4 x + \tan^4 y + 2 \cot^2 x \cdot \cot^2 y = 3 + \sin^2(x + y);$$

$$\forall x, y \in \left[ 0, \frac{\pi}{2} \right]$$

R. Using  $AM = GM, \left( \frac{A+B}{2} \right) \geq \sqrt{AB}$ , for positive values of  $A$  and  $B$ .

10. A.  $\frac{1}{3} \leq \frac{\sec^4 \theta - 3 \tan^2 \theta}{\sec^4 \theta - \tan^2 \theta} < 1$

R. The range of the functions  $f(x) = \frac{x^4 - 3x^2 + 3}{x^4 - x^2 + 1}$  and

$$g(x) = \frac{x^4 - x^2 + 1}{x^4 + x^2 + 1}$$

are the same and that is  $\left[ \frac{1}{3}, 1 \right)$

11. A. If  $\frac{x}{\tan(\theta + \alpha)} = \frac{y}{\tan(\theta + \beta)} = \frac{z}{\tan(\theta + \gamma)}$ , then

$$\sum \frac{x+y}{x-y} \sin^2(\alpha - \beta) = 0$$

R.  $\frac{x+y}{x-y} = \frac{\tan(\theta + \alpha) + \tan(\theta + \beta)}{\tan(\theta + \alpha) - \tan(\theta + \beta)} =$

$$\frac{\sin(2\theta + \alpha + \beta)}{\sin(\alpha + \beta)}$$

12. A. Maximum value of the expression  $|\sqrt{\sin^2 x + 2a^2} - \sqrt{2a^2 - 1 - \cos^2 x}|$ , where  $a$  and  $x$  are real numbers, is  $\sqrt{2}$ .

R.  $|\sqrt{A} - \sqrt{B}| \leq \sqrt{|A - B|}$ .

13. A. If  $A, B, C$  and  $D$  are angles of a quadrilateral and  $\sin A/2 \sin B/2 \sin C/2 \sin D/2 = 1/4$ , then  $A, B, C, D$  is a rectangle.

R. On putting  $A = B = C = D = \pi/2$ , we get  $\sin A/2 = \sin B/2 = \sin C/2 = \sin D/2 = \frac{1}{\sqrt{2}}$  which satisfies the condition that  $\sin A/2 \sin B/2 \sin C/2 \sin D/2 = 1/4$ .

## SECTION-VIII

### INTEGER TYPE QUESTIONS

1. If  $P = \sqrt{9 \cos^2 \theta + 16 \sin^2 \theta} + \sqrt{9 \sin^2 \theta + 16 \cos^2 \theta}$  then find the difference between the maximum and the minimum value of  $P^2$ .

2. If  $\beta$  and  $\gamma$  are positive angles less than two right angles and  $\cos \alpha + \cos(\alpha + \beta) + \cos(\alpha + \beta + \gamma) = 0$  and  $\sin \alpha + \sin(\alpha + \beta) + \sin(\alpha + \beta + \gamma) = 0$ , And it is given that  $\beta = \gamma = \frac{m\pi}{n}$ , then find the value of  $m^2 + n^2$ .

3. If  $\frac{ax}{\cos \theta} + \frac{by}{\sin \theta} = a^2 - b^2$  and  $\frac{ax \sin \theta}{\cos^2 \theta} - \frac{by \cos \theta}{\sin^2 \theta} = 0$ . Then find the value of  $k$  such that  $(ax)^{2/3} + (by)^{2/3} = (a^2 + kb^2)^{2/3}$ .

4. If  $2 \cos A = x + 1/x$   $2 \cos B = y + 1/y$  then find the value of 'k' such that  $k \cos(A - B) = \frac{x}{y} + \frac{y}{x}$ .

5. If  $ABC$  is an equilateral triangle such that  $\sqrt{\sin A} + \sqrt{\sin B} + \sqrt{\sin C} = \sqrt{k \cos \frac{A}{2} \cos \frac{B}{2} \cos \frac{C}{2}}$ .

Then find the value of 'k'.

6. If  $\sqrt{4 \sin^4 \theta + \sin^2 2\theta} + 4 \cos^2 \left( \frac{\theta}{4} + \frac{\theta}{2} \right) = k$ , where  $\theta$  lies in third quadrant then  $k$  is equal to

7. Find the value of 'k', such that  $\sum_{k=1}^{n-1} {}^n C_k [\cos kx \cdot \cos(n+k)x + \sin(n-k)x \cdot \sin(2n-k)x] = (2^n - k) \cos nx$ .

8. Find the value of  $k$  for which the equation  $4 \cos 36^\circ + \cot \left( \frac{15}{2} \right)^\circ = \sum_{r=1}^k \sqrt{r}$  is satisfied.
9. If  $\tan 6\theta = 4/3$  then find value of  $\frac{1}{2}(4 \operatorname{cosec} 2\theta - 3 \sec 2\theta)$
10. If the roots of  $x^3 - 7x^2 + 5 = 0$  are  $\tan \alpha, \tan \beta$  and  $\tan \gamma$  then find the value of  $\sec^2 \alpha \sec^2 \beta \sec^2 \gamma$ .
11. If  $\sin \frac{23\pi}{24} = \sqrt{\frac{2\sqrt{p} - \sqrt{q} - 1}{4\sqrt{r}}}$  then find the value of  $p^2 + q^2 - r^2$ .
12. If  $\sin x + \sin^2 x + \sin^3 x = 1$  then evaluate the value of  $\cos^6 x - 4\cos^4 x + 8\cos^2 x$ .
13. If  $\cot \frac{\pi}{24} = \sqrt{p} + \sqrt{q} + \sqrt{r} + \sqrt{s}$  where  $p, q, r, s \in \mathbb{N}$  &  $p < q < r < s$  then find  $p + q + r - s$ .
14. If  $15 \sin^4 \alpha + 10 \cos^4 \alpha = 6$ , then find value of  $8 \operatorname{cosec}^6 \alpha + 27 \sec^6 \alpha - 241$ .
15. In a  $\Delta ABC$ , if  $\cos A + \cos B + \cos C = \frac{7}{4}$  then  $\frac{R}{r} = \frac{1}{K}$ , find  $K$
16. The value of expression  $E = \cos^4 x - k^2 \cos^2 2x + \sin^4 x$  which is independent of  $x$  is  $\frac{1}{t}$  then find  $t$ .
17. If  $\tan \frac{\pi}{12} = \sqrt{P} - \sqrt{Q}$ ,  $\tan \frac{\pi}{8} = \sqrt{R} - \sqrt{S}$  and  $\sin \frac{\pi}{10} = \frac{\sqrt{T} - \sqrt{S}}{P}$ , where  $P, Q, R, S, T \in \mathbb{N}$ . Then find the sum of the areas of the triangle formed by sides whose lengths are equal to  $P, Q$  &  $T$  and rectangle formed by adjacent sides of length  $R$  &  $S$ .
18. In  $\Delta ABC$  if angles  $A, B, C$  are in A.P. &  $\angle A$  exceeds lowest angle by  $30^\circ$  &  $D$  divides  $BC$  internally in  $1:3$  then  $\frac{\angle BAD}{\angle CAD} = \frac{1}{\sqrt{k}}$ . Find  $k$
19. If  $x = y \cos \frac{2\pi}{3} = z \cos \frac{4\pi}{3}$ , then find  $xy + yz + zx$ .
20.  $(1 - \cot 1^\circ) (1 - \cot 2^\circ) (1 - \cot 3^\circ) \dots \dots (1 - \cot 44^\circ) = 2^n$  then find  $n$ .

## Answer Keys

### SECTION-III

- |         |         |         |         |         |         |         |         |         |         |
|---------|---------|---------|---------|---------|---------|---------|---------|---------|---------|
| 1. (a)  | 2. (c)  | 3. (b)  | 4. (a)  | 5. (a)  | 6. (c)  | 7. (b)  | 8. (d)  | 9. (c)  | 10. (c) |
| 11. (d) | 12. (d) | 13. (c) | 14. (a) | 15. (a) | 16. (a) | 17. (c) | 18. (c) | 19. (a) | 20. (b) |
| 21. (a) | 22. (d) | 23. (b) | 24. (c) | 25. (a) | 26. (d) | 27. (b) | 28. (d) | 29. (b) | 30. (a) |
| 31. (d) | 32. (b) | 33. (a) | 34. (b) | 35. (b) | 36. (c) | 37. (d) | 38. (b) | 39. (b) | 40. (b) |
| 41. (c) | 42. (b) | 43. (a) | 44. (a) | 45. (a) | 46. (b) | 47. (c) | 48. (a) | 49. (a) | 50. (b) |
| 51. (b) | 52. (c) | 53. (d) |         |         |         |         |         |         |         |

### SECTION-IV

- |           |           |                  |               |              |           |              |
|-----------|-----------|------------------|---------------|--------------|-----------|--------------|
| 1. (a, c) | 2. (a, d) | 3. (a, b, d)     | 4. (b, c)     | 5. (b, c, d) | 6. (b, c) | 7. (a, b, d) |
| 8. (b, c) | 9. (c, d) | 10. (a, b, c, d) | 11. (a, b, d) |              |           |              |

### SECTION-V

- |         |         |                 |           |         |         |         |         |         |         |
|---------|---------|-----------------|-----------|---------|---------|---------|---------|---------|---------|
| 1. (b)  | 2. (a)  | 3. (a, b, c, d) | 4. (a, c) | 5. (a)  | 6. (b)  | 7. (d)  | 8. (a)  | 9. (d)  |         |
| 10. (c) | 11. (c) | 12. (c)         | 13. (c)   | 14. (b) | 15. (c) | 16. (b) | 17. (c) | 18. (a) | 19. (c) |
| 20. (c) |         |                 |           |         |         |         |         |         |         |





## HINTS AND SOLUTIONS

### TEXTUAL EXERCISE-1 (SUBJECTIVE)

1. (i) (a)  $240^\circ = 240 \times \frac{\pi}{180} = \frac{4\pi}{3}$   
 (b)  $56^\circ = 56 \times \frac{\pi}{180} = \frac{14\pi}{45}$   
 (c)  $125^\circ 30' = 125^\circ \left(\frac{30}{60}\right)^\circ = \frac{251}{2} = \frac{251}{2} = \frac{251}{2} \times \frac{\pi}{180}$   
 $= \frac{251}{2} \times \frac{\pi}{180} = \frac{251\pi}{360}$
- (ii) (a)  $\left(\frac{5\pi}{3}\right)^\circ = \left(\frac{5\pi}{3} \times \frac{180}{\pi}\right)^\circ = 300^\circ$   
 (b)  $\left(\frac{5\pi}{3}\right)^\circ = \left(\frac{5\pi}{24} \times \frac{180}{\pi}\right)^\circ = \left(\frac{75}{2}\right)^\circ = \left(37\frac{1}{2}\right)^\circ = 37^\circ 30'$   
 (c)  $(2.64)^\circ = \left(2.64 \times \frac{180}{\pi}\right)^\circ = \left(\frac{264}{100} \times \frac{180}{22} \times 7\right)^\circ$   
 $= (151.2)^\circ = 151^\circ.12'$
2.  $\left(\frac{2}{3}x\right)$  grades  $= \left(\frac{2}{3}x \times \frac{9}{10}\right)^\circ = \left(\frac{3}{5}x\right)^\circ$   
 $\Rightarrow \left(\frac{\pi x}{75}\right)^\circ = \left(\frac{\pi x}{75} \times \frac{180}{\pi}\right)^\circ = \left(\frac{12x}{5}\right)^\circ$   
 $\therefore$  As per gives conditions  $\frac{3}{5}x + \frac{3}{2}x + \frac{12}{5}x = 180^\circ$   
 $\Rightarrow x = 40$   
 $\therefore$  Angles are  $24^\circ, 60^\circ$  and  $96^\circ$
3. Let the angles be  $(x - y)^\circ, x^\circ$  and  $(x + y)^\circ$   
 $\Rightarrow x - y + x + x + y = 180^\circ$   
 $\Rightarrow$  Angles are  $(60 - y)^\circ, 60^\circ, (60 + y)^\circ$   
 Now gives  $\frac{60 - y}{(60 + y)} \frac{\pi}{180} = \frac{60}{\pi}$   
 $\Rightarrow \frac{60 - y}{60 + y} = \frac{1}{3} \quad \Rightarrow y = 30$   
 $\therefore$  Required angles are  $30^\circ, 60^\circ, 90^\circ$
4. (i) Angles between hour hand and minute hand [when hour hand is at 3 and minute hand is at 6 figure (1)] is  $90^\circ$

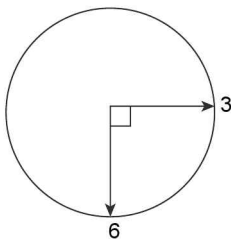

FIGURE - 1

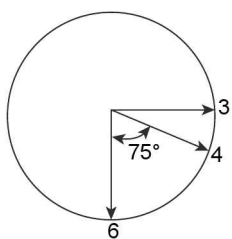

FIGURE - 2

Now at half past three parallel hour hand moves further by an angle of  $\frac{1}{2} \times 30^\circ = 15^\circ$  [Since hour hand moves  $30^\circ$  in 1 hour] see figure (ii)

- $\therefore$  Required angles  $= 90^\circ - 15^\circ = 75^\circ$   
 (ii) As in previous question see figure (i)  
 When hour hand is exactly at 5 and minute hand at 8 angle between them is  $90^\circ$ . Now hour hand further moves by an angle of  $\left(\frac{2}{3} \times 30^\circ\right)$

[because  $40^\circ$  minute  $= 40 \times \frac{1}{60} = \frac{2}{3}$  HRS.]

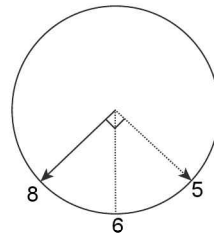

FIGURE - 1

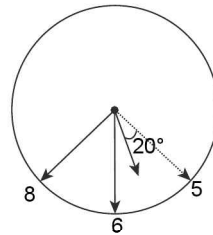
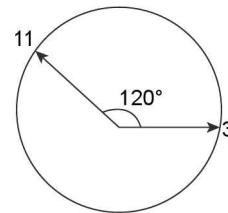

FIGURE - 2

- $\therefore$  Required angle  $= 90^\circ - 20^\circ = 70^\circ$   
 (iii) Quarter past eleven  
 As in previous question. Angle between hour hand and minute hand when hour hand is at parallel minute hand at 3  $= 120^\circ$ . Now hour hand further moves by 15 minute  $= 15 \times \frac{1}{60} = \frac{1}{4}$  Hrs.



- $\therefore$  Angles described further by hour hand  $= \frac{1}{4} \times 30^\circ = (7.5)$   
 Required angle  $= 120^\circ - 7.5^\circ = (112.5)^\circ$ .

5. Let the angle in radians be  $a - d, a, a + d$   
 $\Rightarrow a - d + a + a + d = \pi \Rightarrow a = \frac{\pi}{3}$

$\therefore$  According to question,  $\frac{\frac{\pi}{3} - d}{\frac{\pi}{180}} = \frac{1}{120}$

$$\Rightarrow \frac{\frac{\pi}{3} - d}{60} = \frac{1}{120} \quad \Rightarrow \frac{\pi}{3} - d = \frac{1}{2}$$

$\Rightarrow$  Least angle  $= \frac{1}{2}$  radian

1.98 > Trigonometry

$$\text{Mean angle} = \frac{\pi}{3} \text{ radian}$$

$$\text{Greatest angle} = \left( \frac{2\pi}{3} - \frac{1}{2} \right) \text{ radian}$$

**TEXTUAL EXERCISE-2 (SUBJECTIVE)**

1. Last number of sides of two green polygons be  $n_1$  and  $n_2$

$$\therefore \text{ Given } \frac{n_1}{n_2} = \frac{5}{4} \quad \dots(i)$$

$$\& \left[ \frac{(n_1-2)}{n_1} \times 180^\circ \right] - \left[ \frac{(n_2-2)}{n_2} \times 180^\circ \right] = 9^\circ$$

$$\therefore \left( \frac{n_1-2}{n_1} \right) - \left( \frac{n_2-2}{n_2} \right) = \frac{1}{20} \Rightarrow \frac{2}{n_2} - \frac{2}{n_1} = \frac{1}{20}$$

$$\Rightarrow \frac{1}{n_2} - \frac{1}{n_1} = \frac{1}{40}$$

$$\Rightarrow n_1 - n_2 = \frac{n_1 n_2}{40} \quad \dots(ii)$$

From (1):  $n_1 = \frac{5}{4} n_2$  and put  $n_1$  in equation (ii):

$$\frac{5}{4} n_2 - n_2 = \frac{5 \cdot n_2 \cdot n_2}{40} \Rightarrow n_2 = 8$$

From equation (1)  $n_1 = 10$

$\therefore$  Ans. 10 and 8

2. Let the angle of the quadrilateral be  $(x - 3y)^\circ$ ,  $(x - y)^\circ$ ,  $(x + y)^\circ$ ,  $(x + 3y)^\circ$

Since it sum of angles of a quadrilateral =  $360^\circ$

$$\Rightarrow x - 3y + x - y + x + y + x + 3y = 360^\circ$$

$$\Rightarrow x = 90^\circ$$

$\therefore$  Angles are  $(90 - 3y)^\circ$ ,  $(90 - y)^\circ$ ,  $(90 + y)^\circ$ ,  $(90 + 3y)^\circ$ .

Now gives  $90 + 3y = 2(90 - 3y)$

$$\Rightarrow 9y = 90 \Rightarrow y = 60$$

$$\Rightarrow \text{Least angles} = (90 - 3 \times 10)^\circ = 60^\circ = \frac{\pi}{3} \text{ radian.}$$

3. In 1 sec no of revolutions = 3

$$\Rightarrow \text{In 1 sec distance covered} = 3 \times 2\pi r = 6\pi r$$

[since  $2\pi r$  is the distance covered in one revolutions]

$$= 6 \cdot \frac{22}{7} \times 45 = \frac{5940}{7} \text{ cm} = 848.5 \text{ cm (approx)}$$

$\therefore$  Speed of train 848.5 cm/sec

Ans. 848.5 cm/sec.

4. In  $\frac{L}{9}$  second angle turned =  $80^\circ$

$\therefore$  In 1 second angle turned =  $720^\circ$

$\therefore$  in one second the wheel actually makes 2 revolutions and in one revolutions the distance covered by a point on a rim =  $2\pi r$ .

$\therefore$  Distance covered by a point on rim in one hour =  $60 \times 60 \times 2\pi r \times 2 = 720,000 \times \pi = 22.62 \text{ km (approx)}$

Ans. 22.62 km (app)

5. From figure it is clear that  $\angle \theta = 360^\circ - (90^\circ + 90^\circ + 60^\circ) = 120^\circ = \frac{2\pi}{3}$

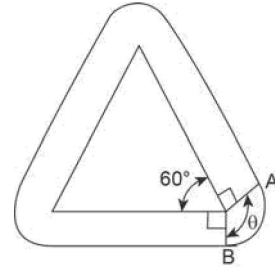

$$\therefore \text{ Length of arc AB} = r\theta = 2 \cdot \frac{2\pi}{3} = \frac{4\pi}{3}$$

$$\therefore \text{ Total distance curved} = (3 \times 4) + 3 \cdot \left( \frac{4\pi}{3} \right)$$

(along the sides) (along the 3 axes) =  $12 + 4\pi$

6. Clearly for circular arc AB  $\angle \theta = 90^\circ = \frac{\pi}{2}$

$$\therefore \text{ Length of arc AB} = r\theta = 2 \times \frac{\pi}{2} = \pi$$

$\therefore$  Total distance traveled by man =  $4 \times (4) + (4 \times \pi) = (16 + 4\pi)\text{m}$

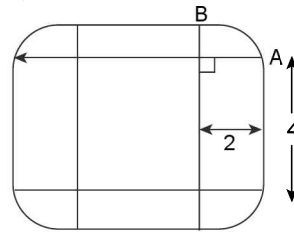

7. As per figure central angle for (i) arc AB =  $360^\circ - (\theta_3 + 90^\circ + 90^\circ) = 180 - \theta_3$

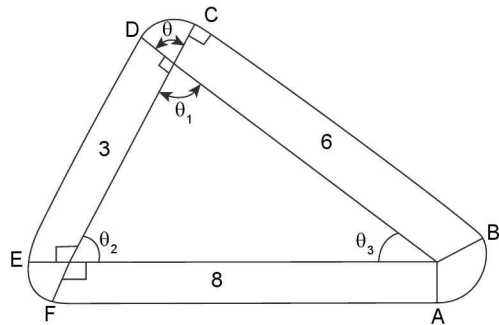

(ii)  $CD = 180 - \theta_1$

(iii)  $EF = 180 - \theta_2$  and for each arc radius = 2

$\therefore$  Total length of all areas [ $\ell = r\theta$ ]

$$= 2 \times \frac{\pi}{180} [180 - \theta_1 + 180 - \theta_2 + 180 - \theta_3]$$

$$= \frac{2\pi}{180} \times [540^\circ - (\theta_1 + \theta_2 + \theta_3)]$$

$$= \frac{2\pi}{180} \times [540^\circ - 180^\circ] = 4\pi$$

$\therefore$  Total distance covered =  $3 + 6 + 8 + 4\pi = (17 + 4\pi)\text{m}$ .

**TEXTUAL EXERCISE-3 (SUBJECTIVE)**

1.  $f(x) = \sin(\pi x) + \cos x$   
 $\therefore$  Period of  $f(x) = \text{LCM of } \left(\frac{2\pi}{\pi} \text{ and } 2\pi\right)$   
 = LCM of  $(2, 2\pi)$   
 But LCM of a rational and irrational does not exist  
 $\therefore f(x)$  is not periodic.
2. By fundamental concept, period of  $f(x) = \text{LCM of } \left(\frac{2\pi}{|\lambda|}, \frac{2\pi}{|\lambda|}\right) = \frac{2\pi}{|\lambda|}$
3. Since the output repeat itself therefore  $f(x)$  is periodic but there are infinite irrational numbers between 2 rational numbers therefore period can't be defined.
4. (a)  $f(x) = \sin x \sin(2x) = \frac{1}{2}[2 \sin(2x) \cdot \sin x]$   
 $= \frac{1}{2}[\cos(x) - \cos(3x)]$   
 $[2 \sin A \sin B = \cos(A - B) - \cos(A + B)]$   
 Now period of  $\cos x = 2\pi$   
 Period of  $\cos(3x) = \frac{2\pi}{3}$   
 $\therefore$  Period of  $f(x) = \text{LCM of } 2\pi \text{ and } \frac{2\pi}{3} = 2\pi$
- (b)  $f(x) = \cot(2x) \cdot \sec(3x)$   
 Let  $T$  be the period of  $f(x)$   
 $\cot[2(x + T)] \sec[3(x + T)] = \cot(2x) \sec(3x)$   
 Clearly  $2\pi$  is at least value of  $T$ , Satisfying it.  
 $\therefore$  Period =  $2\pi$   
*Aliter:* Period of  $\cot(2x) = \frac{\pi}{2}$   
 Period  $\sec(3x) = \frac{2\pi}{3}$   
 $\therefore$  LCM of  $\frac{\pi}{2}$  &  $\frac{2\pi}{3} = \frac{\text{LCM of } \pi \text{ & } 2\pi}{\text{HCF of } 2 \text{ & } 3} = \frac{2\pi}{1}$   
 $\therefore$  Period of  $f(x)$  is  $2\pi$
- (c) Using  $f(x + T) = f(x)$   
 $\cot(\pi(x + T)) \sec^2(3\pi(x + T)) = \cot(\pi x) \sec^2(3\pi x)$   
 $\Rightarrow \cot(\pi x + \pi T) \sec^2(3\pi x + 3\pi T) = \cot(\pi x) \sec^2(3\pi x)$   
 Clearly  $T = 1$  is at least value  
 $[\because \cot(x + \theta) = \cot \theta, \sec(\pi + \theta) = -\sec \theta]$   
*Aliter:* Period of  $\cot(\pi x) = \pi/\pi = 1$   
 Period of  $\sec^2(3\pi x) = \frac{\pi}{3\pi} = \frac{1}{3}$   
 $[\text{Period of } \sec^2 x = \pi]$   
 $\therefore$  Period of  $f(x) = \text{LCM of } 1 \text{ and } 1/3 = 1$
- (d)  $f(x) = \cot^3(x) \cdot \sec(3\pi x)$   
 Period of  $\sec(3\pi x) = \frac{2\pi}{3\pi} = \frac{2}{3}$   
 Now LCM of  $\pi$  and  $2/3$  does not exist. Therefore  $f(x)$  is not periodic

- (e) Period of  $2\sin^2(3x) = \pi/3$   
 Period  $\tan(4x) = \pi/4$   
 Period of  $\cot(6x) = \pi/6$   
 Period of  $|\operatorname{cosec}(8x)| = \pi/8$   
 Period of  $\sec^3(10x) = 2\pi/10 = \pi/5$   
 Period of  $\sqrt{\cot 12x} = \frac{\pi}{12}$   
 $[\text{Since period of } |\operatorname{cosec} x| = \frac{\pi}{2} \text{ . Also if } f(x) \text{ is periodic with period } T, \text{ item } \sqrt{f(x)} \text{ is also periodic with periodic } T]$   
 $\therefore$  Period of  $f(x) = \text{LCM of } \left(\frac{\pi}{3}, \frac{\pi}{4}, \frac{\pi}{8}, \frac{\pi}{5}, \frac{\pi}{12}, \frac{\pi}{6}\right) = \pi$
- (f) Period of  $2 \sin^2(6x) = \pi/6$ , Period of  $3 \tan\left(\frac{4x}{3}\right) = \frac{\pi}{4/3} = \frac{3\pi}{4}$   
 Period of  $4\cos^2(6x) = \pi/6$ , period of  $|\operatorname{cosec} 8x| = \frac{\pi}{8}$   
 Period of  $\sec^3\left(\frac{16x}{3}\right) = \frac{2\pi}{3} = \frac{3\pi}{8}$   
 Period of  $\sqrt{\cot\left(\frac{12x}{5}\right)} = \frac{\pi}{12} = \frac{5\pi}{12}$   
 $\therefore$  Period of  $f(x) = \text{LCM of } \left(\frac{\pi}{6}, \frac{3\pi}{4}, \frac{\pi}{6}, \frac{\pi}{8}, \frac{3\pi}{8}, \frac{5\pi}{12}\right)$   
 $= \frac{\text{LCM of } (\pi, 3\pi, \pi, \pi, \pi, 3\pi, 15\pi)}{\text{HCF of } (6, 4, 6, 8, 8, 12)} = \frac{15\pi}{2}$
5. (a) Period of  $\sin\left(2\pi x + \frac{\pi}{4}\right) = \frac{2\pi}{2\pi} = 1$   
 Period of  $2 \sin\left(3\pi x + \frac{\pi}{3}\right) = \frac{2\pi}{3\pi} = \frac{2}{3}$   
 $\Rightarrow$  Period of  $f(x) = \text{LCM of } 1 \text{ and } 2/3 = 2$
- (b)  $f(x) = \cos^2 x + \sin^2 x = 1$   
 Here  $f(x)$  is a constant function so  $f(x)$  is periodic but period can't be found.
- (c)  $f(x) = \cos^6 x + \sin^6 x$   
 $f(x) = (\cos^2 x)^3 + (\sin^2 x)^3 = (\cos^2 x + \sin^2 x)^3 - 3 \cos^2 x \sin^2 x [\cos^2 + \sin^2 x]$   
 $[a^3 + b^3 = (a + b)^3 - 3ab(a + b)]$   
 $\Rightarrow f(x) = 1 - 3\cos^2 x \sin^2 x \cdot 4/4 = 1 - \frac{3}{4} \sin^2(2x)$   
 $\therefore$  Period of  $f(x) = \pi/2$  [Since period of  $\sin^2 x = \pi$ ]  
*Aliter:* Period of  $\cos^6 x = \pi$   
 Period of  $\sin^6 x = \pi$   
 Their exist a number  $\pi/2$  less than LCM of  $(\pi \text{ and } \pi)$  for which  $\cos^6 x$  and  $\sin^6 x$  are interconvertible.  
 $\Rightarrow$  Period of  $f(x) = \pi/2$
- (d)  $f(x) = \sin^2\left(2x + \frac{\pi}{3}\right) + \left|\tan\left(\pi x + \frac{\pi}{6}\right)\right|$   
 Period of  $\sin^2\left(2x + \frac{\pi}{3}\right) = \frac{2\pi}{2} = \pi$

1.100 > Trigonometry

Period of  $\left| \tan\left(\pi x + \frac{\pi}{6}\right) \right| = \frac{\pi}{\pi} = 1$

LCM of 1 and  $\pi$  does not exist

$\Rightarrow f(x)$  is not periodic.

(e)  $f(x) = 2$ . By basic concept we can see that period of  $f(x)$  is  $2\pi$

6. (a)  $f(x) = \sqrt{\cos x - 1}$

Since  $-1 \leq \cos x \leq 1 \Rightarrow -2 \leq \cos x - 1 \leq 0$

$\therefore f(x) \in \sqrt{[-2, 0]} \Rightarrow f(x)$

Range =  $\{0\}$

*Aliter:*  $y = \sqrt{\cos x - 1} \Rightarrow y^2 + 1 = \cos x$

$y^2 + 1 \geq 1$ , so LHS  $\geq 1$  and  $-1 \leq \cos x \leq 1$

$\Rightarrow$  Minimum value of LHS = 1, Maximum value of RHS = 1

Therefore equating holds for which  $y = 0$

(b)  $f(x) = \frac{1}{\sqrt{1 - |\operatorname{cosec} x|}}$

Since  $|\operatorname{cosec} x| \geq 1$

$\Rightarrow 1 - |\operatorname{cosec} x| \leq 0$

$\therefore$  Range of  $f(x) = \phi$

7. (a)  $f(x) = \frac{1}{\sqrt{1 - \tan^2 x}}$ . For domain  $1 - \tan^2 x > 0$

$\Rightarrow \tan^2 x < 1$ . Also  $\tan^2 x \geq 0$

$\Rightarrow 0 \leq \tan^2 x < 1 \Rightarrow -1 < -\tan^2 x < 0$

$\Rightarrow 0 < 1 - \tan^2 x < 1 \Rightarrow 0 < \sqrt{1 - \tan^2 x} \leq 1$

Applying reciprocal law  $\frac{1}{1} \leq \frac{1}{\sqrt{1 - \tan^2 x}} < \frac{1}{0}$

$\Rightarrow 1 \leq f(x) < \infty$

Range of  $f(x) = [1, \infty)$

(b)  $f(x) = \sqrt{2 - \sec x}$

For domain  $2 - \sec x \geq 0$

$\Rightarrow \sec x \leq 2$

*Case I:*  $1 \leq \sec x \leq 2$

$\Rightarrow -2 \leq -\sec x \leq -1 \Rightarrow 0 \leq 2 - \sec x \leq 1$

$\Rightarrow 0 \leq \sqrt{2 - \sec x} \leq 1 \Rightarrow 0 < f(x) \leq 1$

*Case II:*  $\sec x \leq -1$

$\Rightarrow -\sec x \geq 1 \Rightarrow 2 - \sec x \geq 3$

$\Rightarrow \sqrt{2 - \sec x} \geq \sqrt{3} \therefore f(x) \in [\sqrt{3}, \infty)$

$\therefore$  Range of  $f(x) = [0, 1] \cup [\sqrt{3}, \infty)$

(c)  $f(x) = \sqrt{|\cot x| - 1}$

For domain  $|\cot x| - 1 \geq 0$  and when  $|\cot x| - 1 \geq 0$  then

$\sqrt{|\cot x| - 1} \geq 0$

$\therefore$  Range of  $f(x) = [0, \infty)$

(d)  $f(x) = \tan\left(\frac{\pi}{2}[x]\right)$

(i) When  $[x] = 0$  then  $f(x) = 0$

(ii) When  $[x] \neq 0$ , then  $f(x) = \tan\left(\frac{\pi}{2} \times \text{integer}\right)$  and  $f(x)$  is not defined

$\therefore$  Range of  $f(x) = \{0\}$ .

(e)  $f(x) = \frac{1}{\sqrt{|\tan x| - \tan x}}$

For domain  $|\tan x| - \tan x > 0$

$\Rightarrow |\tan x| > \tan x$

$\Rightarrow \tan x < 0 \Rightarrow \tan x \in (-\infty, 0)$

$\Rightarrow f(x) = \frac{1}{\sqrt{-2 \tan x}}$

$\Rightarrow$  Range of  $f(x) = (0, \infty)$

(f)  $y = \sqrt{(1 - \cos x)}\sqrt{(1 - \cos x)}\sqrt{(1 - \cos x)} \dots \dots \infty$

$\Rightarrow y = \sqrt{(1 - \cos x)} \cdot y$

$y^2 = (1 - \cos x)y \Rightarrow y^2 - y(1 - \cos x) = 0$

$\Rightarrow y[y - (1 - \cos x)] = 0$

$\Rightarrow y = 0$  or  $y = 1 - \cos x$

Now  $-1 \leq -\cos x \leq 1 \Rightarrow 0 \leq 1 - \cos x \leq 2$

$\therefore$  Range is  $[0, 2]$

(g)  $f(x) = \cos^2 x - 5 \cos x - 6 = \left(\cos x - \frac{5}{2}\right)^2 - \frac{25}{4} - 6$

$= \left(\cos x - \frac{5}{2}\right)^2 \left(\frac{7}{2}\right)^2$

Now  $-1 \leq \cos x \leq 1 \Rightarrow -1 - \frac{5}{2} \leq \cos x - \frac{5}{2} \leq 1 - \frac{5}{2}$

$\Rightarrow -\frac{7}{2} \leq \cos x - \frac{5}{2} \leq -\frac{3}{2}$

$\Rightarrow \frac{9}{4} \leq \left(\cos x - \frac{5}{2}\right)^2 \leq \frac{49}{4}$

$\Rightarrow \frac{9}{4} - \frac{49}{4} \leq \left(\cos x - \frac{5}{2}\right)^2 - \frac{49}{4} \leq \frac{49}{4} - \frac{4}{4}$

$\Rightarrow -10 \leq f(x) \leq 0$

$\therefore$  Range of  $f(x) = [-10, 0]$

*Aliter:* Let  $\cos x = t$

$\Rightarrow f(x) = t^2 - 5t - 6$

Now draw the graph of  $t^2 - 5t - 6$

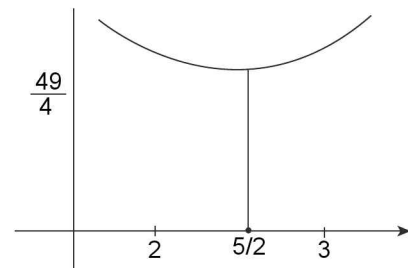

$\therefore$  minimum value of  $ax^2 + bx + c = 0$  is

$-\frac{D}{4a}$  and  $xc = \frac{-b}{2a}$  But  $-1 \leq t \leq 1$

$\Rightarrow f(x)$  is maximum at  $t = -1$  [ $1 + 5 - 6 = 0$ ]

$\Rightarrow f(x)$  and minimum at  $t = 1$  [ $1 - 5 - 6 = -10$ ]

$\therefore$  Range of  $f(x) = [-10, 0]$

**TEXTUAL EXERCISE-4 (SUBJECTIVE)**

1. (a)  $f(x) = x^3 - 2x^5$ ,  $f(-x) = -x^3 + 2x^5 = -(x^3 - 2x^5) = -f(x)$   
 $\therefore f$  is an odd function.  
 [ $\therefore$  Sum of 2 odd functions is always an odd function.]
- (b)  $f(x) = x \sin x$   
 $f(-x) = -x \sin(-x) = x \sin x = f(x)$   
 $\therefore f$  is an even function.  
 [ $\therefore$  Product of 2 odd functions is an even function]
- (c)  $f(x) = 2^x + 2^{-x}$   
 $f(-x) = 2^{-x} + 2^x = f(x)$   
 $\Rightarrow f$  is an even function.
- (d)  $f(x) = 2^x - 2^{-x}$   
 $f(-x) = 2^{-x} - 2^x = -(2^x - 2^{-x}) = -f(x)$   
 $\Rightarrow f(x)$  is an odd function.
- (e)  $f(x) = \frac{2x}{1+x^2}$ ,  $f(-x) = \frac{-2x}{1+x^2} = -f(x)$   
 $\therefore f(x)$  is an odd function.
- (f)  $f(x) = \log\left(\frac{1-x}{1+x}\right) = \log(1-x) - \log(1+x)$   
 $f(-x) = \log(1+x) - \log(1-x) = -f(x)$   
 $\Rightarrow f(x)$  is an odd function.
- (g)  $f(x) = \log(2x + \sqrt{4x^2 + 1})$   
 $f(-x) = \log(-2x + \sqrt{4x^2 + 1})$   
 Now  $f(x) + f(-x) = \log(\sqrt{4x^2 + 1} + 2x) + \log[\sqrt{4x^2 + 1} - (2x)]$   
 $= \log[\sqrt{4x^2 + 1} + 2x][\sqrt{4x^2 + 1} - (2x)]$   
 $= \log((4x^2 + 1) - (4x^2)) = \log 2 = 0$   
 $\Rightarrow f(-x) = -f(x)$   
 Hence  $f(x)$  is an odd function.

**TEXTUAL EXERCISE-1 (OBJECTIVE)**

1. (d) Let the hour hand and minute hand coincide after 't' minutes.  
 $\Rightarrow 6t = \frac{t}{2} + 360^\circ.n, n \in I^+$   
 [ $\therefore$  Minute hand describes an angle of  $6^\circ$  in 1 minute and hour hand describes an angle of  $\frac{1}{2}^\circ$  in one minute]  
 $\Rightarrow 12t = t + n.720 \quad \Rightarrow 11t = n.720$   
 $\Rightarrow t = \frac{720}{11}.n$   
 Also  $t \leq 720$   
 For instance  $n = 1$ ,  $t = 65.4$  (approx)  
 $\Rightarrow$  In between  $65^{\text{th}}$  and  $66^{\text{th}}$  minute both hands coincide  
 $\Rightarrow$  We get  $n = 1, 2, \dots, 11$   
 $\therefore$  Both hands coincide, 11 times in a period of 12 hand.
2. (d) As in previous question,  $11 \times 2 = 22$  times

3. (d) Let the angle between hour hand and minute hand is  $90^\circ$  after 't' minute  
 $\Rightarrow 6t - \frac{1}{2}t = 90^\circ \pm 360^\circ.n, n \in I^+$   
 Also  $0 \leq t \leq 144^\circ$   
 $\Rightarrow \frac{11}{2}t = 90^\circ(1 + |4n|)$   
 $\Rightarrow t = \frac{180^\circ}{11}(1 + 4|n|), n \in I$  and also  $0 \leq t \leq 144^\circ$   
 $\therefore$  possible values of n are  $-22, -21, -20, \dots, 0, 1, 22, \dots, 21$   
 Therefore 44 values.
4. (a) From question no. (3), required volume  $7 \times 44 = 308$ .
5. (b) As in previous question  $\frac{11}{2}t = 180^\circ + 360^\circ.n$   
 $\Rightarrow t = \frac{360^\circ}{11}[1 + 2n]$   
 $n = 0, 1, 2, \dots, 21$   
 $\therefore 22$  values
6. (b) Gain = 5 seconds in 3 minutes.  
 Let the actual time = x min to 4  
 The gain in time =  $(540 - x)$  minutes.  
 Total gain =  $x = \left(\frac{540 - x}{3}\right) \times \frac{5}{60}$  minutes.  
 $180x = (540 - x) \times 5 \Rightarrow 180x + 5x = 540 \times 5$   
 $\Rightarrow 185x = 540 \times 5$   
 $\Rightarrow x = 14\frac{22}{37}$  min to 4
7. (a) Greatest angle is opposite to the greatest side:  
 $\frac{BD}{CD} = \frac{12}{16} = \frac{3}{4}$

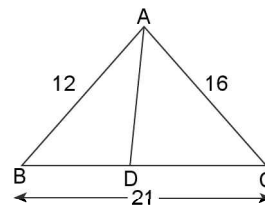

- $\therefore BD = 3k, CD = 4k$   
 Also  $BC = 21 \Rightarrow 3k + 4k = 21$   
 $\Rightarrow k = 3$   
 $\therefore$  The required parts are 9 cm, 12 cm.
8. (d) Required angle =  $\frac{(n-2) \times 180^\circ}{n} = [\text{polygon of sides}]$   
 Here  $n = 12$   
 $\therefore$  Required angle =  $\frac{10 \times 180^\circ}{12} = \frac{5\pi}{6}$
9. (b) Let the polygon has n sides then sum of all angles =  $(n-2) \times 180^\circ$   
 Also sum of all angles =  $\frac{n}{2}[2a + (n-1)d]$

1.102 > Trigonometry

and  $a = \frac{5\pi}{12}$ ,  $d = 10^\circ$  (gives)

$\Rightarrow (n-2) \times 180^\circ = \frac{n}{2} [2 \times 75^\circ + (n-1) \times 10^\circ] \Rightarrow n = 4$

10. (b) In  $\triangle BEF$ ;  $\angle 1 + \angle B + \angle E = 180^\circ$  .....(i)  
 In  $\triangle AGC$ ;  $\angle 2 + \angle A + \angle C = 180^\circ$  .....(ii)

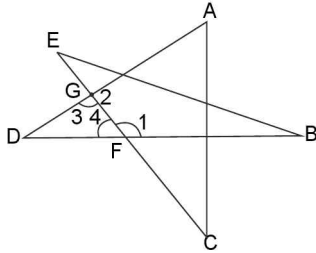

Also  $\angle 3 = 180^\circ - \angle 2$ ,  $\angle 4 = 180^\circ - \angle 1$   
 $\therefore \angle 3 + \angle 4 = 360^\circ - \angle 1 + \angle 2$   
 Again in  $\triangle DGF$ ;  $\angle D + \angle 3 + \angle 4 = 180^\circ$   
 $\Rightarrow \angle D + 360^\circ - (\angle 1 + \angle 2) = 180^\circ$   
 $\Rightarrow \angle 1 + \angle 2 = \angle D + 180^\circ$  .....(iii)  
 Adding(1),(2),(3) we get;  $\angle A + \angle B + \angle C + \angle D + \angle E = 180^\circ$

11. (c) Using  $\ell = r\theta$   
 We get  $\theta = \frac{\ell}{r} = \frac{1}{3}$  radian.  
 12. (b) Using  $\ell = r\theta$ , we get;  $15 = r \cdot 3/4 \Rightarrow r = 20$  cm.  
 13. (c) Ist path: AE  $\rightarrow$  quarter circle  
 IInd path: EF  $\rightarrow$  straight line  
 IIIrd path: FD  $\rightarrow$  quarter circle

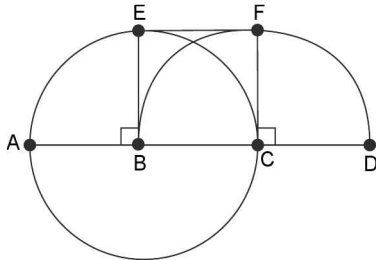

$\therefore$  Total distance  $= \frac{2\pi \cdot 1}{4} + 1 + \frac{2\pi}{4} = \pi + 1$

14. (a)  $(n-2) \times 180^\circ = 360^\circ \times 2$   
 $\Rightarrow (n-2) = 4 \Rightarrow n = 6$   
 15. (b)  $\triangle ABC$  is an equilateral  $\triangle$   
 $|DE| = 2m$ . For arc of  $\angle \theta = (90^\circ + 30^\circ) = 120^\circ$

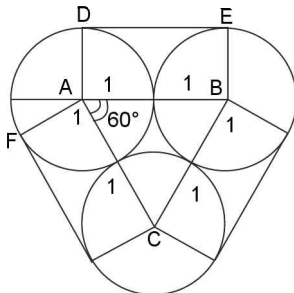

$\therefore$  Length of arc DE  $= r\theta = 1 \cdot \frac{2\pi}{3}$

$\therefore$  Total length of slope  $= 3 \times \left[ \frac{2\pi}{3} + 2 \right] = (2\pi + 6)m$

16. (c)  $|AB| = |AC| = |BC| = 6$  feet  
 $\therefore \triangle ABC$  is an equilateral  $\triangle$ ,  $\angle ABD = 60^\circ$   
 $\Rightarrow \sin 60^\circ = \frac{AD}{AB}$

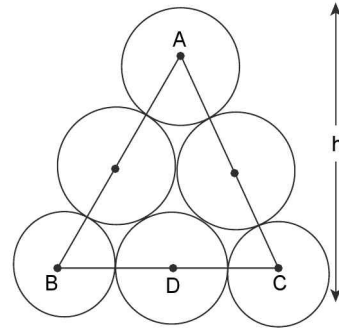

$\Rightarrow AD = AB \cdot \frac{\sqrt{3}}{2} = 6 \times \frac{\sqrt{3}}{2} = 3\sqrt{3}$

$\therefore h = \frac{3}{2} + 3\sqrt{3} + \frac{3}{2} = 3 + 3\sqrt{3}$

17. (a) Let 'r' be the radius of each log then as in Q.16

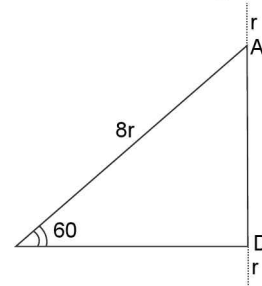

$AD = 8r \cdot \sin 60^\circ = 4\sqrt{3}r$

Also  $h = 4\sqrt{3}r + 2r$

$\Rightarrow 11 = 2r [1 + 2\sqrt{3}]$

$\Rightarrow$  Diameter  $= 2r = \frac{11}{1 + 2\sqrt{3}}$

$= \frac{11}{(1 + 2\sqrt{3})} \times \frac{(1 - 2\sqrt{3})}{(1 - 2\sqrt{3})} = 2\sqrt{3} - 1$

18. (a) Let after 't' minutes past 2 the angle between the hands is  $90^\circ$

$\Rightarrow \left| \frac{1}{2}t - 6t \right| = 90^\circ \Rightarrow \frac{1}{2}t = 90^\circ \Rightarrow t = \frac{180^\circ}{11}$

$\therefore$  After  $\left( 16 \frac{4}{11} \right)$  minute the angle is  $90^\circ$

$\Rightarrow 16 \frac{4}{11}$  minute part 2.

19. (a) Required area = Area of a sector

$$\text{Here } \theta = 6^\circ \times 35 = 210^\circ = \frac{7\pi}{6}$$

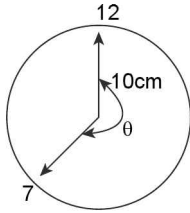

$$\text{Required area } \frac{1}{2}r^2\theta = \frac{1}{2} \times 100 \times \frac{7\pi}{6} = 183.3 \text{ cm}^2$$

### TEXTUAL EXERCISE-5 (SUBJECTIVE)

1. (a)  $(\sec^2 A - 1) \cot^2 A = \tan^2 A \cdot \cot^2 A = 1$   
 (b)  $\cos A \cdot \operatorname{cosec} A \cdot \sqrt{\sec^2 A - 1} = \cot A \cdot \tan A = 1$   
 (c)  $(\operatorname{cosec}^2 A - 1) \tan^2 A = \cot^2 A \cdot \tan^2 A = 1$   
 (d)  $(1 - \cos^2 A)(1 + \cot^2 A) = \sin^2 A \cdot \operatorname{cosec}^2 A = 1$   
 (e)  $\sin A \operatorname{cosec} A \cdot \sqrt{\operatorname{cosec}^2 A - 1} = 1 \times \cot A \neq 1$   
 (f)  $(1 + \tan^2 A)(1 - \sin^2 A) = \sec^2 A \cdot \cos^2 A = 1$   
 (g)  $\sec^2 A - \sin^2 A \cdot \sec^2 A = \sec^2 A - \tan^2 A = 1$   
 (h)  $\frac{1}{1 + \sin^2 A} + \frac{1}{1 + \operatorname{cosec}^2 A} = \frac{1}{1 + \sin^2 A} + \frac{1}{1 + \frac{1}{\sin^2 A}} = 1$

$$\begin{aligned} \text{(i)} \quad \frac{\tan^2 A \cdot \sin^2 A}{\tan^2 A - \sin^2 A} &= \frac{\tan^2 A \cdot \sin^2 A}{\frac{\sin^2 A}{\cos^2 A} - \sin^2 A} \\ &= \frac{\tan^2 A \cdot \sin^2 A}{\sin^2 A \left[ \frac{1 - \cos^2 A}{\cos^2 A} \right]} = \frac{\tan^2 A}{\tan^2 A} = 1 \end{aligned}$$

$$\begin{aligned} \text{(j)} \quad \frac{\cot^2 A \cdot \operatorname{cosec}^2 A}{\cot^2 A - \operatorname{cosec}^2 A} &= \frac{\cot^2 A \cdot \operatorname{cosec}^2 A}{\frac{\cos^2 A}{\sin^2 A} - \frac{1}{\sin^2 A}} \\ &= \frac{[\cot^2 A \cdot \operatorname{cosec}^2 A]}{-(\sin^2 A)} \cdot \sin^2 A \neq 1 \end{aligned}$$

2. (a)  $\frac{1 - \tan^2 \theta}{1 + \tan^2 \theta} = \frac{1 - \tan^2 \theta}{\sec^2 \theta}$   
 $= \frac{1}{\sec^2 \theta} - \frac{\tan^2 \theta}{\sec^2 \theta} = \cos^2 \theta - \sin^2 \theta$   
 $= 1 - \sin^2 \theta - \sin^2 \theta = 1 - 2\sin^2 \theta = 1 - 2(1 - \cos^2 \theta)$   
 $= 2\cos^2 \theta - 1$

$$\begin{aligned} \text{(b)} \quad \frac{1 + \cos \theta}{1 - \cos \theta} &= \frac{1 + \cos \theta}{1 - \cos \theta} \times \frac{1 + \cos \theta}{1 + \cos \theta} = \left( \frac{1 + \cos \theta}{\sin \theta} \right)^2 \\ &= (\operatorname{cosec} \theta + \cot \theta)^2 \\ \text{Also } \frac{1 - \cos \theta}{1 + \cos \theta} &= \frac{(1 - \cos \theta)^2}{(1 + \cos \theta)(1 - \cos \theta)} \\ &= \left( \frac{1 - \cos \theta}{\sin \theta} \right)^2 = (\operatorname{cosec} \theta - \cot \theta)^2 \end{aligned}$$

$$\begin{aligned} \text{(c)} \quad \sqrt{\frac{1 - \sin \theta}{1 + \sin \theta}} &= \sqrt{\frac{(1 - \sin \theta)(1 - \sin \theta)}{(1 + \sin \theta)(1 - \sin \theta)}} \\ &= \sqrt{\left( \frac{1 - \sin \theta}{\cos \theta} \right)^2} = |\sec \theta - \tan \theta| \end{aligned}$$

3. Given expression  $(\sec \theta + \operatorname{cosec} \theta)(\sin \theta + \cos \theta)$

$$\begin{aligned} &= \left( \frac{1}{\cos \theta} + \frac{1}{\sin \theta} \right) (\sin \theta + \cos \theta) \\ &= \frac{(\sin \theta + \cos \theta)^2}{\sin \theta \cos \theta} = \frac{1 + 2\sin \theta \cos \theta}{\sin \theta \cos \theta} \\ &= \sec \theta \cdot \operatorname{cosec} \theta + 2 = \text{R.H.S.} \end{aligned}$$

4. L.H.S. =  $(\sec^2 \theta + \tan^2 \theta)(\operatorname{cosec}^2 \theta + \cot^2 \theta)$

$$\begin{aligned} &= \left( \frac{1}{\cos^2 \theta} + \frac{\sin^2 \theta}{\cos^2 \theta} \right) \times \left[ \frac{1}{\sin^2 \theta} + \frac{\cos^2 \theta}{\sin^2 \theta} \right] \\ &= \frac{(1 + \sin^2 \theta)(1 + \cos^2 \theta)}{\sin^2 \theta \cos^2 \theta} = \frac{2 + \sin^2 \theta \cos^2 \theta}{\sin^2 \theta \cos^2 \theta} \\ &= 1 + 2 \sec^2 \theta \operatorname{cosec}^2 \theta = \text{R.H.S.} \end{aligned}$$

5. L.H.S. =  $\frac{\sin x + \cos x}{\cos^3 x} = \frac{\sin x}{\cos^2 x \cos x} + \frac{1}{\cos^2 x}$

$$\begin{aligned} &= \tan x \sec^2 x + \sec^2 x = \tan x [1 + \tan^2 x] + 1 + \tan^2 x \\ &= \tan^3 x + \tan^2 x + \tan^2 x + 1 \end{aligned}$$

6. (a) L.H.S. =  $\frac{1 + \cos \theta + \sin \theta}{1 + \cos \theta - \sin \theta}$

$$\begin{aligned} &= \frac{(1 + \cos \theta) + \sin \theta}{(1 + \cos \theta) - \sin \theta} \times \frac{(1 + \cos \theta) + \sin \theta}{(1 + \cos \theta) + \sin \theta} \\ &= \frac{1 + \cos^2 \theta + \sin^2 \theta + 2\sin \theta + 2\cos \theta + 2\sin \theta \cos \theta}{(1 + \cos \theta)^2 - \sin^2 \theta} \\ &= \frac{2(\cos \theta + 1) + 2\sin \theta(\cos \theta + 1)}{2\cos \theta(\cos \theta + 1)} = \frac{1 + \sin \theta}{\cos \theta} \end{aligned}$$

- (b) LHS =  $2[\sin^6 \theta + \cos^6 \theta] - 3[\sin^4 \theta + \cos^4 \theta] + 1 \dots \dots \text{(i)}$

$$\begin{aligned} \text{Now } \sin^6 \theta + \cos^6 \theta &= (\sin^2 \theta)^3 + (\cos^2 \theta)^3 = (\sin^2 \theta + \cos^2 \theta)^3 - 3\sin^2 \theta \cos^2 \theta (\sin^2 \theta + \cos^2 \theta) \\ &= 1 - 3\sin^2 \theta \cos^2 \theta \dots \dots \text{(ii)} \end{aligned}$$

$$\text{Also } \sin^4 \theta + \cos^4 \theta = (\sin^2 \theta + \cos^2 \theta)^2 - 2\sin^2 \theta \cos^2 \theta$$

$$= 1 - 2\sin^2 \theta \cos^2 \theta \dots \dots \text{(iii)}$$

$\therefore$  From (1), (2), (3) we get LHS = 0

### TEXTUAL EXERCISE-6 (SUBJECTIVE)

1. (a)  $\cos A = \cos\left(\frac{11\pi}{13}\right) = \cos\left(4\pi - \frac{\pi}{3}\right) = \cos\left(\frac{\pi}{3}\right) = \frac{1}{2}$

$$\sin A = \sin\left(\frac{11\pi}{13}\right) = \sin\left(4\pi - \frac{\pi}{3}\right) = \sin\left(-\frac{\pi}{3}\right) = \frac{-\sqrt{3}}{2}$$

$$\therefore \cos A - \sin A = \frac{1 + \sqrt{3}}{2}; \tan A + \cot A = -\sqrt{3} - \frac{1}{\sqrt{3}} = \frac{-4}{\sqrt{3}}$$

- (b)  $\cos A = \cos\left(\frac{7\pi}{4}\right) = \cos\left(2\pi - \frac{\pi}{4}\right) = \frac{1}{\sqrt{2}}$



1.104 > Trigonometry

$$\sin A = \sin\left(\frac{7\pi}{4}\right) = \sin\left(2\pi - \frac{\pi}{4}\right) = \frac{-1}{\sqrt{2}}$$

$$\therefore \cos A - \sin A = \frac{2}{\sqrt{2}} = \sqrt{2}$$

$$\text{Also } \tan A = \tan\left(2\pi - \frac{\pi}{4}\right) = 1 \cot A = -1$$

$$\tan A + \cot A = -2$$

2.  $\alpha = 825^\circ \Rightarrow \sin \alpha = \sin(700^\circ + 105^\circ) = \sin(105^\circ)$

$\therefore \sin \alpha$  is positive as  $105^\circ$  lies in second quadrant.

$\cos \alpha = \cos(825^\circ) = \cos(105^\circ)$  is negative as  $\cos \theta$  is negative in 2<sup>nd</sup> quadrant.

$\Rightarrow \sin \alpha - \cos \alpha$  is positive  $\alpha = 140^\circ$  from graph  $\sin \alpha + \cos \alpha$  is negative

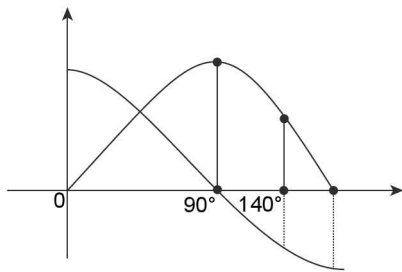

3.  $\alpha = 235^\circ$

$$\Rightarrow \tan \alpha = \tan(180^\circ + 55^\circ) = \tan 55^\circ > 1$$

$$\therefore \tan \alpha - \cot \alpha = \frac{\tan^2 \alpha - 1}{\tan \alpha} > 0$$

[As  $\tan 55^\circ > 1$  and  $\tan \alpha > 0$ ]

$\therefore \tan \alpha - \cot \alpha$  is positive  $\alpha = 325^\circ$

$\Rightarrow$  Negative

$$\Rightarrow \tan \alpha = \tan(360^\circ - 35^\circ) = -\tan 35^\circ$$

$\therefore \tan \alpha$  is negative, Also  $\tan 35^\circ < 1$

$\therefore \tan \alpha - \cot \alpha$  is positive

4.  $\alpha = 125^\circ$

$$\Rightarrow \sec \alpha - \operatorname{cosec} \alpha = \sec 125^\circ - \operatorname{cosec} 125^\circ$$

$$= \frac{1}{\cos 125^\circ} - \frac{1}{\sin 125^\circ} = \frac{\sin 125^\circ - \cos 125^\circ}{\sin 125^\circ \cos 125^\circ}$$

$$= \frac{\sin 125^\circ - \cos(90^\circ + 35^\circ)}{\sin 125^\circ \cos 125^\circ} = \frac{\sin 125^\circ + \sin 35^\circ}{\sin 125^\circ \cos 125^\circ}$$

Now  $\sin 35^\circ$  and  $\sin 125^\circ$  are positive and  $\cos 125^\circ$  is negative.

$\therefore \sec \alpha - \operatorname{cosec} \alpha$  is negative. Similarly for  $\alpha = 215^\circ$

**TEXTUAL EXERCISE-7 (SUBJECTIVE)**

1. (a)  $\sin \theta = x + \frac{1}{x}, [x \neq 0]$

if  $x > 0, x + \frac{1}{x} \geq 2$

if  $x < 0, x + \frac{1}{x} \leq -2$

But  $-1 \leq \sin \theta \leq 1$

$\Rightarrow$  Given equation has no solution

(b)  $\sec \theta = \frac{x}{1+x^2}$

$$\Rightarrow (\sec \theta)x^2 - x + \sec \theta = 0$$

For real solutions in  $x, D \geq 0$

$$\Rightarrow 1 - 4 \sec^2 \theta \geq 1$$

$$\Rightarrow \sec^2 \theta \leq \frac{1}{4}, \text{ But } \sec^2 \theta \geq 1$$

$\Rightarrow$  No solution

(c)  $\sin \theta = \frac{1+x^2}{2x} \Rightarrow x^2 - (2\sin \theta)x + 1 = 0$

Which is quadratic in  $x$ .

$$\therefore D \geq 0 \Rightarrow 4\sin^2 \theta - 4 \geq 0$$

$$\Rightarrow \sin^2 \theta \geq 1$$

But  $\sin^2 \theta \leq 1 \Rightarrow$  Equality holds

$$\Rightarrow \sin^2 \theta = 1 \Rightarrow \sin \theta = \pm 1$$

$$\Rightarrow \theta = \left\{ \frac{\pi}{2}, \frac{3\pi}{2} \right\} \text{ in } [0, 2\pi]$$

(d)  $\sin^2 \theta = \frac{x^2 + y^2}{2xy}$

$$\sin \theta (x - y)^2 \geq 0 \Rightarrow x^2 + y^2 - 2xy \geq 0$$

$$\Rightarrow \frac{x^2 + y^2}{2xy} \geq 1 \left( \because \sin^2 \theta = \frac{x^2 + y^2}{2xy} \Rightarrow x, y > 0 \text{ or } x, y < 0 \right)$$

Also  $\sin^2 \theta \leq 1 \Rightarrow$  Equality holds

$$\Rightarrow \sin^2 \theta = 1 \Rightarrow \theta = (2k + 1)\pi/2, k \in \mathbb{Z}$$

$$\Rightarrow x^2 + y^2 = 2xy \Rightarrow (x - y)^2 = 0$$

$$\Rightarrow y = x \neq 0.$$

2.  $\sin \theta = |x| + 1$

$$|x| + 1 \geq 1 \text{ and } \sin \theta \in [-1, 1]$$

$$\Rightarrow \text{Equality holds} \Rightarrow \sin \theta = 1$$

$$\Rightarrow \text{Required order pairs are } \left(0, \frac{-3\pi}{2}\right), \left(0, \frac{\pi}{2}\right) \text{ and } \left(0, \frac{5\pi}{2}\right)$$

3. (a) From graph 2 values.

(b) From graph only 1 value.

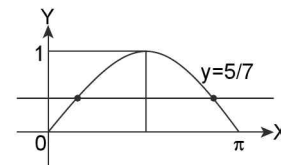

4. (a) Using A.M  $\geq$  G.M

$$\frac{4 \tan^2 x + 49 \cot^2 x}{2} \geq \sqrt{4 \tan^2 x \cdot 49 \cot^2 x}$$

$$\Rightarrow 4 \tan^2 x + 49 \cot^2 x \geq 2 \times 14$$

$$\Rightarrow 4 \tan^2 x + 49 \cot^2 x \geq 28$$

(b) Using A.M  $\geq$  G.M

$$\frac{8 \sin^4 x + 2 \operatorname{cosec}^4 x}{2} \geq \sqrt{8 \sin^4 x \cdot 2 \operatorname{cosec}^4 x}$$

$$\Rightarrow 8 \sin^4 x + 2 \operatorname{cosec}^4 x \geq 8$$

5. (a)  $2 \cos^2 x - 7 \cos x + 3 = 0$

$$2 \cos^2 x - 6 \cos x - \cos x + 3 = 0$$

$$(2 \cos x - 1)(\cos x - 3) = 0$$

$$\cos x = \frac{1}{2}, \cos x = 3$$

$\cos x = 3$  is impossible but  $\cos x = \frac{1}{2}$  is possible.

(b)  $6\cos^2x + 7\sin x - 8 = 0$

$$\Rightarrow 6[1 - \sin^2x] + 7\sin x - 8 = 0$$

$$\Rightarrow -6\sin^2x + 7\sin x - 2 = 0$$

$$\Rightarrow 6\sin^2x - 7\sin x + 2 = 0$$

$$\Rightarrow 6\sin^2x - 3\sin x - 4\sin x + 2 = 0$$

$$\Rightarrow 3\sin x [2\sin x - 1] - 2 [2\sin x - 1] = 0$$

$$\Rightarrow (2\sin x - 1)(3\sin x - 2) = 0$$

$$\Rightarrow \sin x = \frac{1}{2}, \sin x = \frac{2}{3}$$

Both possible

(c)  $\sin^2x + 2\sin^2 \frac{x}{2} + 4 = 0$

$$\Rightarrow (1 - \cos^2x) + (1 - \cos x) + 4 = 0$$

$$\Rightarrow -\cos^2x - \cos x + 6 = 0$$

$$\Rightarrow \cos^2x + \cos x - 6 = 0$$

$$\Rightarrow \cos^2x + 3\cos x - 2\cos x - 6 = 0$$

$$\Rightarrow \cos x (\cos x + 3) - 2(\cos x + 3) = 0$$

$$\Rightarrow (\cos x - 2)(\cos x + 3) = 0$$

$$\Rightarrow \cos x = 2 \text{ or } \cos x = -3$$

Both are impossible as  $\cos x \in [-1, 1]$

$\Rightarrow$  The given equation has no real root  $x$ .

6.  $x = \sum_{n=0}^{\infty} \cos^{2n} \phi = 1 + \cos^2 \phi + \cos^4 \phi + \dots + \infty$   
 $= \frac{1}{1 - \cos^2 \phi} = \operatorname{cosec}^2 \phi$

Similarly  $y = \frac{1}{1 - \sin^2 \phi} = \sec^2 \phi$

and  $z = \frac{1}{1 - \cos^2 \phi \cdot \sin^2 \phi} = \frac{1}{1 - \frac{1}{y} \cdot \frac{1}{x}} = \frac{xy}{xy - 1}$

$$\Rightarrow z = \frac{xy}{xy - 1} \dots(i)$$

$$\text{Also } x + y = \frac{1}{\sin^2 \phi} + \frac{1}{\cos^2 \phi} = \frac{\cos^2 \phi + \sin^2 \phi}{\sin^2 \phi \cos^2 \phi}$$

$$= \frac{1}{\sin^2 \phi \cdot \cos^2 \phi} = xy$$

$$\Rightarrow \text{from (1); } z = \frac{x + y}{(x + y) - 1}$$

$$\Rightarrow xz + yz - z = (x + y)$$

$$\Rightarrow x + y + z = (x + y)z$$

$$\Rightarrow x + y + z = xyz$$

**TEXTUAL EXERCISE-8 (SUBJECTIVE)**

1. (a)  $\sin 120^\circ = \sin (180^\circ - 60^\circ) = \sin 60^\circ = \cos 30^\circ$   
 (b)  $\tan 150^\circ = \tan (180^\circ - 30^\circ) = -\tan 30^\circ$  or  $\tan(90^\circ + 60^\circ) = -\cot 60^\circ$

- (c)  $\cos 300^\circ = \cos(360^\circ - 60^\circ) = \cos 60^\circ = \sin 30^\circ$   
 (d)  $\tan 1140^\circ = \tan(1080^\circ + 60^\circ) = \tan(6 \times 180^\circ + 60^\circ) = \tan(3(360^\circ) + 60^\circ) = \tan 60^\circ = \cot 30^\circ$   
 (e)  $\sec 1320^\circ = \sec(1260^\circ + 60^\circ) = \sec(7(180^\circ) + 60^\circ) = \sec(3(360^\circ) + 180^\circ + 60^\circ) = \sec(180^\circ + 60^\circ) = -\sec 60^\circ = -\operatorname{cosec} 30^\circ$

2. (a)  $\sec\left(\frac{3\pi}{2} - A\right) \sec\left(\frac{\pi}{2} - A\right) - \tan\left(\frac{3\pi}{2} - A\right) \times \tan\left(\frac{\pi}{2} + A\right) + 1 = -\operatorname{cosec} A \cdot \operatorname{cosec} A - \cot A \times -\cot A + 1 = -\operatorname{cosec}^2 A + \cot^2 A + 1 = 0$   
 (b)  $\cot A + \tan(\pi + A) + \tan\left(\frac{\pi}{2} + A\right) + \tan(2\pi - A) = \cot A + \tan A + (-\cot A) + (-\tan A) = 0$

3.  $A + B + C = 180^\circ \Rightarrow A + B = \pi - C$   
 $\Rightarrow \cos(A + B) = \cos(\pi - C) = -\cos C$   
 Also  $A + B + C = \pi \Rightarrow B + C = \pi - A$   
 $\Rightarrow \frac{B + C}{2} = \frac{\pi - A}{2}$

$$\Rightarrow \sin\left(\frac{B + C}{2}\right) = \sin\left(\frac{\pi - A}{2}\right) = \cos(A/2)$$

4. If ABCD is a quadrilateral then  $A + B + C + D = 2\pi$

$$\Rightarrow \frac{B + C}{2} = \pi - \left(\frac{A + D}{2}\right)$$

$$\Rightarrow \cos\left(\frac{B + C}{2}\right) = \cos\left(\pi - \frac{A + D}{2}\right) = -\cos\left(\frac{A + D}{2}\right)$$

$$\Rightarrow \cos\left(\frac{B + C}{2}\right) + \cos\left(\frac{A + D}{2}\right) = 0$$

Also  $\frac{A + C}{4} = \frac{\pi}{2} - \left(\frac{B + D}{4}\right)$

$$\Rightarrow \tan\left(\frac{A + C}{4}\right) = \tan\left(\frac{\pi}{2} - \left(\frac{B + D}{4}\right)\right) = \cot\left(\frac{B + D}{4}\right)$$

**TEXTUAL EXERCISE-2 (OBJECTIVE)**

1. (c)  $-1 \leq \sin \theta \leq 1$  and  $a^2 + b^2 > a^2 - b^2$   
 $\Rightarrow \frac{a^2 + b^2}{a^2 - b^2} > 1$   
 $\therefore$  Only  $\tan \theta = 45$  is possible  
 2. (d)  $A + B = \pi/2$   
 $\tan A + \tan B = \frac{a}{b} + \frac{b}{a} = \frac{a^2 + b^2}{ab} = \frac{c^2}{ab}$

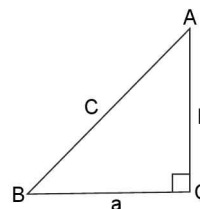

1.106 > Trigonometry

3. (b)  $\sin^2 17.5 + \sin^2 72.5 = \sin^2 17.5 + \cos^2 17.5 = 1$   
 $[\because \sin(90 - \theta) = \cos\theta]$

4. (a)  $\cos 1 \cos 2^\circ \dots \cos 90^\circ \dots \cos 179^\circ = 0$

5. (c)  $\sin^2 5^\circ + \sin^2 10^\circ + \sin^2 15^\circ + \dots + \sin^2 90^\circ$   
 Now  $\sin^2 90^\circ = 1, \sin^2 85^\circ = \cos^2 5^\circ$   
 $\sin^2 80^\circ = \cos^2 10^\circ, \sin^2 50^\circ = \cos^2 40^\circ$   
 $\therefore$  Given expression  $= \sin^2 5^\circ + \sin^2 10^\circ + \sin^2 15^\circ + \dots + \sin^2 40^\circ + \sin^2 45^\circ + \cos^2 40^\circ + \cos^2 35^\circ + \dots + \cos^2 5^\circ + \sin^2 90^\circ = 8 + \frac{1}{2} = 9\frac{1}{2}$

6. (a) Since  $\cos\left(\frac{7\pi}{16}\right) = \cos\left(\frac{\pi}{2} - \frac{\pi}{16}\right) = \sin\left(\frac{\pi}{16}\right)$  and

$$\cos\left(\frac{5\pi}{16}\right) = \cos\left(\frac{\pi}{2} - \frac{3\pi}{16}\right) = \sin\left(\frac{3\pi}{16}\right)$$

$\therefore$  L.H.S.

$$= \cos^2\left(\frac{\pi}{16}\right) + \cos^2\left(\frac{3\pi}{16}\right) + \sin^2\left(\frac{3\pi}{16}\right) + \sin^2\left(\frac{\pi}{16}\right) = 2$$

7. (b) LHS  $= 3(\sin x - \cos x)^4 + 6(\sin x + \cos x)^2 + 4(\sin^6 x + \cos^6 x)$   
 $= 3[(\sin x - \cos x)^2]^2 + 6[\sin^2 x + \cos^2 x + 2\sin x \cos x] + 4[(\sin^2 x)^3 + (\cos^2 x)^3 - 3\sin^2 x \cos^2 x (\sin^2 x + \cos^2 x)]$   
 $= 3[1 - 2\sin x \cos x]^2 + 6[1 + 2\sin x \cos x] + 4[1 - 3\sin^2 x \cos^2 x]$   
 $= 3[1 + 4\sin^2 x \cos^2 x - 4\sin x \cos x] + 10 + 12\sin x \cos x - 12\sin^2 x \cos^2 x = 13$

8. (a) LHS  $= \left(1 + \cos\frac{\pi}{6}\right)\left(1 + \cos\frac{\pi}{3}\right)\left(1 + \cos\frac{2\pi}{3}\right)\left(1 + \cos\frac{7\pi}{6}\right)$   
 $= \left(1 + \frac{\sqrt{3}}{2}\right)\left(1 + \frac{1}{2}\right)\left(1 - \frac{1}{2}\right)\left(1 - \frac{\sqrt{3}}{2}\right)$   
 $= \left(1 - \frac{3}{4}\right)\left(1 - \frac{1}{4}\right) = \frac{3}{16}$

9. (c)  $\cos 480^\circ \sin 150^\circ + \sin 60^\circ \cos 390^\circ = \cos(360^\circ + 120^\circ)$   
 $\sin(180^\circ - 30^\circ) + \frac{\sqrt{3}}{2} \cdot \cos(360^\circ + 30^\circ)$   
 $= -\frac{1}{2} \times \frac{1}{2} + \frac{\sqrt{3}}{2} \times \frac{\sqrt{3}}{2} = \frac{1}{2}$

10. (b)  $\sin 120^\circ \cos 150^\circ - \cos 240^\circ \sin 330^\circ$   
 $= \sin(180^\circ - 60^\circ) \cos(180^\circ - 30^\circ) - \cos(180^\circ + 60^\circ) \sin(360^\circ - 30^\circ)$   
 $= -\sin 60^\circ \cos 30^\circ - (-\cos 60^\circ) \times (-\sin 30^\circ)$   
 $= -\left(\frac{\sqrt{3}}{2} \times \frac{\sqrt{3}}{2}\right) - \frac{1}{2} \times \frac{1}{2} = -\frac{3}{4} - \frac{1}{4} = -1$

11. (d)  $\cos(270^\circ + \theta) \times \cos(90^\circ - \theta) - \sin(270^\circ - \theta) \cos \theta$   
 $= \sin \theta \times \sin \theta - (-\cos \theta \cos \theta) = \sin^2 \theta + \cos^2 \theta = 1$

12. (d)  $\sin^6 \theta + \cos^6 \theta = (\sin^2 \theta)^3 + (\cos^2 \theta)^3$   
 $= (\sin^2 \theta + \cos^2 \theta)^3 - 3\sin^2 \theta \cos^2 \theta (\sin^2 \theta + \cos^2 \theta)$   
 $\Rightarrow \sin^6 \theta + \cos^6 \theta = 1 - 3\sin^2 \theta \cos^2 \theta$   
 $\Rightarrow \sin^6 \theta + \cos^6 \theta + 3\sin^2 \theta \cos^2 \theta = 1$

13. (a)  $-1 \leq \cos(4x - 5) \leq 1$   
 $\Rightarrow -3 \leq 3\cos(4x - 5) \leq 3$   
 $\Rightarrow -3 + 4 \leq 3\cos(4x - 5) + 4 \leq 3 + 4$   
 $\Rightarrow 3\cos(4x - 5) + 4 \in [1, 7]$

14. (d)  $\tan 1^\circ \cdot \tan 2^\circ \cdot \tan 3^\circ \dots \tan 44^\circ \cdot \tan 45^\circ \cdot \tan 46^\circ \cdot \tan 89^\circ = 1$   
 $[\because \text{since } \tan 89^\circ = \cot 1^\circ, \tan 88^\circ = \cot 2^\circ \text{ and } \tan 45^\circ = 1]$

15. (d)  $\cos x + \cos^2 x = 1 \Rightarrow \cos x = 1 - \cos^2 x = \sin^2 x$   
 $\Rightarrow (\cos x + \cos^2 x)^2 = 1$   
 $\Rightarrow \cos^6 x + \cos^3 x + 3\cos^5 x + 3\cos^4 x = 1$   
 $\Rightarrow \sin^1 x + 3\sin^4 x + 3\sin^8 x + \sin^6 x - 1 = 0$

TEXTUAL EXERCISE-9 (SUBJECTIVE)

1.  $\sin \theta = 1/3 \Rightarrow \cos \theta = \pm \sqrt{1 - \frac{1}{9}} = \pm \frac{2\sqrt{2}}{3}$

$$\therefore \tan \theta = \pm \frac{1}{2\sqrt{2}}$$

2.  $\tan \theta = \frac{1}{\sqrt{7}}, \tan^2 \theta = \frac{1}{7}$

$$\Rightarrow \sec^2 \theta = 1 + \tan^2 \theta = \frac{8}{7}$$

$$\text{Also } \cot^2 \theta = 7 \Rightarrow 1 + \cot^2 \theta = 8$$

$$\Rightarrow \operatorname{cosec}^2 \theta = 8$$

$$\Rightarrow \text{LHS} = \frac{\operatorname{cosec}^2 \theta - \sec^2 \theta}{\operatorname{cosec}^2 \theta + \sec^2 \theta} = \frac{8 - \frac{8}{7}}{8 + \frac{8}{7}} = \frac{48}{64} = \frac{3}{4}$$

3.  $\tan^2 \theta + \sec \theta = 5$

$$\Rightarrow \sec^2 \theta - 1 + \sec \theta = 5 \Rightarrow \sec^2 \theta + \sec \theta - 6 = 0$$

$$\Rightarrow (\sec \theta + 3)(\sec \theta - 2) = 0$$

$$\Rightarrow \sec \theta = -3, \sec \theta = 2$$

$$\Rightarrow \cos \theta = -\frac{1}{3} \text{ or } \cos \theta = \frac{1}{2}$$

4.  $\tan \theta + \cot \theta = 2$

$$\text{Squaring both sides we get } \tan^2 \theta + \cot^2 \theta + 2 = 4$$

$$\Rightarrow \tan^2 \theta + \cot^2 \theta = 2$$

$$\text{Since } x + \frac{1}{x} \geq 2 \text{ if } x > 0 \text{ and equality holds if } x = 1$$

$$\Rightarrow \tan^2 \theta = 1 \Rightarrow \tan \theta = \pm 1$$

$$\text{But } \tan \theta + \cot \theta = 2 \text{ (given)}$$

$$\Rightarrow \tan \theta = 1 \Rightarrow \theta = \frac{\pi}{4}$$

$$\Rightarrow \sin \theta = \frac{1}{\sqrt{2}}$$

5.  $\sec^2 \theta = 2 + \tan \theta \Rightarrow 1 + \tan^2 \theta = 2 + \tan \theta$

$$\Rightarrow \tan^2 \theta - \tan \theta - 1 = 0 \Rightarrow \tan \theta = \frac{1 \pm \sqrt{1+4}}{2}$$

$$\Rightarrow \tan \theta = \frac{1 \pm \sqrt{5}}{2}$$

**TEXTUAL EXERCISE-3 (OBJECTIVE)**

1. (c)  $a^2 = b^2 + c^2$   
 Now  $\cos^2 B + \cos^2 C = \cos^2\left(\frac{\pi}{2} - C\right) + \cos^2 C$   
 $= \sin^2 C + \cos^2 C = 1$  [ $\because B + C = \pi/2$ ]
2. (b)  $\cot 54^\circ = \cot(90^\circ - 36^\circ) = \tan 36^\circ$  and  $\cot 70^\circ = \tan 20^\circ$   
 $\Rightarrow \frac{\cot 54^\circ}{\tan 36^\circ} + \frac{\tan 20^\circ}{\cot 70^\circ} = \frac{\tan 36^\circ}{\tan 36^\circ} + \frac{\tan 20^\circ}{\cot 20^\circ} = 1 + 1 = 2$
3. (b)  $\sum_{i=1}^n \sin \theta_i = n \Rightarrow \sin \theta_1 + \sin \theta_2 + \sin \theta_3 + \dots + \sin \theta_n = n$   
 This is possible only when  $\sin \theta_1 = \sin \theta_2 = \dots = \sin \theta_n = 1$   
 $\Rightarrow \theta_1 = \theta_2 = \dots = \theta_n = \frac{\pi}{2}$  (each)  $\Rightarrow \sum_{i=1}^n \cos \theta_i = 0$
4. (b)  $(a + b)^2 = 4ab \sin^2 \theta \Rightarrow \sin^2 \theta = \frac{(a+b)^2}{4ab}$   
 Now  $0 \leq \sin^2 \theta \leq 1 \Rightarrow 0 \leq \frac{(a+b)^2}{4ab} \leq 1$   
 $\Rightarrow \frac{(a+b)^2}{4ab} \leq 1 \Rightarrow (a+b)^2 - 4ab \leq 0$   
 $\Rightarrow (a-b)^2 \leq 0$   
 Therefore only equality holds  
 $\Rightarrow a = b$  [ $a, b \in \mathbb{R}$ ]
5. (b)  $\log(\tan 1^\circ) + \log(\tan 2^\circ) + \dots + \log(\tan 89^\circ) = \log[\tan 1^\circ \cdot \tan 2^\circ \dots \tan 89^\circ] = \log 1 = 0$   
 [ $\because \log(m \cdot n) = \log m + \log n$ ]
6. (b)  $\sin^6 \theta \cos^6 \theta = (\sin^2 \theta + \cos^2 \theta)^3 - 3\sin^2 \theta \cos^2 \theta (\sin^2 \theta + \cos^2 \theta) = 1 - 3\sin^2 \theta \cos^2 \theta$   
 $\sin^4 \theta + \cos^4 \theta = (\sin^2 \theta + \cos^2 \theta)^2 - 2\sin^2 \theta \cos^2 \theta = 1 - 2\sin^2 \theta \cos^2 \theta$   
 $\Rightarrow 2[\sin^4 \theta + \cos^4 \theta] - 3(\sin^4 \theta + \cos^4 \theta) + 1$   
 $= 2 - 6\sin^2 \theta \cos^2 \theta - 3 + 6\sin^2 \theta \cos^2 \theta + 1 = 0$
7. (c) As in question no. 6.
8. (c)  $\frac{\cos A}{3} = \frac{\cos B}{4} = \frac{1}{5}$ , B lies in IVth quadrant  
 $\cos A = \frac{3}{5} \Rightarrow \sin^2 A = 1 - \cos^2 A = 1 - \frac{9}{25} = \frac{16}{25}$   
 $\sin A = \pm \frac{4}{5}$ ,  $\sin A = \frac{-4}{5}$   
 Similarly  $\sin B = \sqrt{1 - \cos^2 B} = \sqrt{1 - \frac{16}{25}} = -\frac{3}{5}$   
 $\Rightarrow 2\sin A + 4\sin B = -\frac{8}{5} - \frac{12}{5} = -4 \therefore -\frac{\pi}{2} < A, B < 0$
9. (a)  $\sec \theta = m$  and  $\tan \theta = n$   
 $\Rightarrow \sec^2 \theta - \tan^2 \theta = m^2 - n^2$   
 Also  $\sec^2 \theta - \tan^2 \theta = 1$   
 $\Rightarrow m^2 - n^2 = 1 \Rightarrow (m+n) = \frac{1}{m-n}$

$$\begin{aligned} \text{Now given expression} &= \frac{1}{m} \left[ (m+n) + \frac{1}{m+n} \right] \\ &= \frac{1}{m} [(m+n) + (m-n)] = 2 \end{aligned}$$

10. (b)  $\cos \theta = \frac{-\sqrt{3}}{2} \Rightarrow \theta$  lies in II<sup>nd</sup> quadrant  
 $\sin^2 \theta = 1 - \cos^2 \theta = 1 - \frac{3}{4} = \frac{1}{4} \Rightarrow \sin \theta = \frac{1}{2}$   
 $\tan \theta = \frac{-1}{\sqrt{3}}$   
 Also  $\sin \alpha = \frac{-\sqrt{3}}{5}$ ,  $\cos^2 \alpha = 1 - \frac{3}{25} = \frac{22}{25}$   
 $\Rightarrow 25 \cos^2 \alpha + \sqrt{3} \tan \theta = 22 - 1 = 21$
11. (c)  $\cos\left(\frac{7\pi}{8}\right) = \cos\left(\pi - \frac{\pi}{8}\right) = -\cos\left(\frac{\pi}{8}\right)$   
 $\Rightarrow \cos(5\pi/8) = -\cos(3\pi/8)$   
 $\Rightarrow \text{Given expression} = 2 \left[ \cos^4\left(\frac{\pi}{8}\right) + \cos^4\left(\frac{3\pi}{8}\right) \right]$   
 $= 2 \left[ \cos^2\left(\frac{\pi}{8}\right) + \cos^2\left(\frac{3\pi}{8}\right) \right]$   
 $= 2 \left[ \left( \frac{1 + \cos\left(\frac{\pi}{4}\right)}{2} \right)^2 + \left( \frac{1 + \cos\left(\frac{3\pi}{4}\right)}{2} \right)^2 \right]$   
 $= \frac{1}{2} \left[ \left( 1 + \frac{1}{\sqrt{2}} \right)^2 + \left( 1 - \frac{1}{\sqrt{2}} \right)^2 \right] = \frac{1}{2} [3] = \frac{3}{2}$
12. (c)  $12\cot^2 \theta - 31 \operatorname{cosec} \theta + 32 = 0$   
 $\Rightarrow 12[\operatorname{cosec}^2 \theta - 1] - 31 \operatorname{cosec} \theta + 32 = 0$   
 $\Rightarrow 12 \operatorname{cosec}^2 \theta - 31 \operatorname{cosec} \theta + 20 = 0$   
 $\Rightarrow 12 \operatorname{cosec}^2 \theta - 16 \operatorname{cosec} \theta - 15 \operatorname{cosec} \theta + 20 = 0$   
 $\Rightarrow 4 \operatorname{cosec} \theta [3 \operatorname{cosec} \theta - 4] - 5 [3 \operatorname{cosec} \theta - 4] = 0$   
 $\Rightarrow (3 \operatorname{cosec} \theta - 4)(4 \operatorname{cosec} \theta - 5) = 0$   
 $\Rightarrow \operatorname{cosec} \theta = \frac{4}{3}, \frac{5}{4} \Rightarrow \sin \theta = \frac{3}{4} \text{ or } \frac{4}{5}$
13. (c)  $\frac{\tan A}{1 + \sec A} + \frac{1 + \sec A}{\tan A} = \frac{\sin A}{1 + \cos A} + \frac{1 + \cos A}{\sin A}$   
 $= \frac{1 - \cos A}{\sin A} + \frac{1 + \cos A}{\sin A} = 2 \operatorname{cosec} A$

**TEXTUAL EXERCISE-10 (SUBJECTIVE)**

1. (a)  $\frac{\sin(A-B)}{\cos B \cos A} = \frac{\sin A \cos B - \cos A \sin B}{\cos A \cos B} = \tan A - \tan B$   
 Similarly  $\frac{\sin(B-C)}{\cos B \cos C} = \tan B - \tan C$  and  
 $\frac{\sin(C-A)}{\cos C \cos A} = \tan C - \tan A$

$$\Rightarrow \frac{\sin(A-B)}{\cos A \cos B} + \frac{\sin(B-C)}{\cos B \cos C} + \frac{\sin(C-A)}{\cos C \cos A} = 0$$

(b)  $\cos \alpha \cos(\gamma - \alpha) - \sin \alpha \sin(\gamma - \alpha) = \cos(\alpha + \gamma - \alpha) = \cos \gamma$   
 $[\because \cos A \cos B - \sin A \sin B = \cos(A + B)]$

(c)  $\cos(\alpha + \beta) \cos \gamma - (\cos \beta + \gamma) \cos \alpha = (\cos \alpha \cos \beta - \sin \alpha \sin \beta) \cos \gamma - \cos \alpha [\cos \beta \cos \gamma - \sin \beta \sin \gamma]$   
 $= \cos \alpha \sin \beta \sin \gamma - \sin \alpha \sin \beta \cos \gamma = \sin \beta [\cos \alpha \sin \gamma - \sin \alpha \cos \gamma] = \sin \beta \sin(\gamma - \alpha)$

(d) L.H.S. =  $\sin((n+1)\theta) \sin((n-1)\theta) + \cos((n+1)\theta) \cos((n-1)\theta) = \cos[(n+1)\theta - (n-1)\theta] = \cos(2\theta) = \text{R.H.S.}$

$[\because \cos(A-B) = \cos A \cos B + \sin A \sin B]$

(e) L.H.S. =  $\cos((n+2)\alpha) \cos((n+1)\alpha) + \sin((n+2)\alpha) \sin((n+1)\alpha) = \cos([(n+2) - (n+1)]\alpha) = \cos \alpha = \text{R.H.S.}$

2. (a)  $\text{LHS} = \cot\left(\frac{\pi}{4} + \theta\right) \times \cot\left(\frac{\pi}{4} - \theta\right)$   
 $= \frac{\cot \theta - 1}{\cot \theta + 1} \times \frac{\cot \theta + 1}{\cot \theta - 1} = 1 \left[ \because \cot(A \pm B) = \frac{\cot A \cot B \pm 1}{\cot B \pm \cot A} \right]$

(b)  $\text{LHS} = 1 + \tan \theta \cdot \tan\left(\frac{\theta}{2}\right) = 1 + \frac{\sin \theta \sin(\theta/2)}{\cos \theta \cos(\theta/2)}$   
 $\frac{\cos \theta \cos\left(\frac{\theta}{2}\right) + \sin \theta \sin\left(\frac{\theta}{2}\right)}{\cos \theta \cos\left(\frac{\theta}{2}\right)} = \frac{\cos\left(\theta - \frac{\theta}{2}\right)}{\cos \theta \cos\left(\frac{\theta}{2}\right)} = \sec \theta$

Also  $\tan \theta \cot\left(\frac{\theta}{2}\right) - 1 = \frac{\sin \theta}{\cos \theta} \cdot \frac{\cos\left(\frac{\theta}{2}\right)}{\sin\left(\frac{\theta}{2}\right)} - 1$

$$= \frac{\sin \theta \cos\left(\frac{\theta}{2}\right) - \cos \theta \sin\left(\frac{\theta}{2}\right)}{\sin\left(\frac{\theta}{2}\right) \cos \theta} = \frac{\sin\left(\theta - \frac{\theta}{2}\right)}{\cos \theta \sin\left(\frac{\theta}{2}\right)}$$

$$= \frac{1}{\cos \theta} = \sec \theta$$

Hence  $1 + \tan \theta \tan(\theta/2) = \tan \theta \cot(\theta/2) - 1 = \sec \theta$

3. L.H.S. =  $\cos(60 - A) \cos A \cos(60 + A) = \cos A \cdot \cos(60 + A) \cos(60 - A) = \cos A [\cos^2 60^\circ - \sin^2 A] = \cos[1/4 - \sin^2 A]$

$[\because \cos(A+B) \cos(A-B) = \cos^2 A - \sin^2 B]$

$$= \cos A \left[ \frac{1}{4} - (1 - \cos^2 A) \right]$$

$$= \cos A \left[ \cos^2 A - \frac{3}{4} \right] = \frac{4 \cos^3 A - 3 \cos A}{4}$$

$$= \frac{1}{4} \cos(3A) = \text{R.H.S.}$$

4. Since  $\sin A \sin(60^\circ - A) \sin(60^\circ + A) = \sin A [\sin^2 60^\circ - \sin^2 A]$   
 $= \sin A \left[ \frac{3}{4} - \sin^2 A \right] = \frac{3 \sin A - 4 \sin^3 A}{4} = \frac{\sin(3A)}{4}$

Also from previous questions, we have  $\cos(60^\circ - A) \cos A \cos(60^\circ + A) = \frac{\cos(3A)}{4}$

$\Rightarrow$  Dividing both equations we get,  $\tan(60^\circ - A) \tan A \cdot \tan(60^\circ + A) = \tan 3A$ .

5. Let  $z = \cos \theta + i \sin \theta$  ... (i)

$\Rightarrow \frac{1}{z} = \cos \theta + i \sin \theta$  ... (ii)

$\therefore 2 \cos \theta = z + \frac{1}{z} \Rightarrow \cos \theta = \frac{1}{2} \left( z + \frac{1}{z} \right)$

$\Rightarrow \cos^7 \theta = \frac{1}{2^7} \left[ z + \frac{1}{z} \right]^7$

$\Rightarrow \cos^7 \theta = \frac{1}{128} \left[ 7c_0 z^7 + 7c_1 z^6 \cdot \frac{1}{z} + 7c_2 z^5 \cdot \frac{1}{z^2} + 7c_3 z^4 \cdot \frac{1}{z^3} + 7c_4 z^3 \cdot \frac{1}{z^4} + 7c_5 z^2 \cdot \frac{1}{z^5} + 7c_6 z \cdot \frac{1}{z^6} + 7c_7 \left( \frac{1}{z} \right)^7 \right]$

$= \frac{1}{128} \left[ z^7 + 7z^5 + 21z^3 + 35z + 35 \frac{1}{z} + 21 \frac{1}{z^3} + 7 \frac{1}{z^5} + \frac{1}{z^7} \right]$

$= \frac{1}{128} \left[ \left( z^7 + \frac{1}{z^7} \right) + 7 \left( z^5 + \frac{1}{z^5} \right) + 21 \left( z^3 + \frac{1}{z^3} \right) + 35 \left( z + \frac{1}{z} \right) \right]$  ... (iii)

Now from (1) and (2);  $z^n + \frac{1}{z^n} = 2 \cos(n\theta)$  [By de Moivre's theorem]

$\Rightarrow z^7 + \frac{1}{z^7} = 2 \cos(7\theta)$

$\Rightarrow z^5 + \frac{1}{z^5} = 2 \cos(5\theta), z^3 + \frac{1}{z^3} = 2 \cos(3\theta)$  and

$z + \frac{1}{z} = 2 \cos \theta$

$\therefore \cos^7 \theta = 1/128$   
 $[2 \cos(7\theta) + 7.2 \cos(5\theta) + 21 \times 2 \cos(3\theta) + 35 \times 2 \cos \theta]$   
 $= \frac{1}{64} [\cos(7\theta) + 7 \cos(5\theta) + 21 \cos(3\theta) + 35 \cos \theta]$

**TEXTUAL EXERCISE-11 (SUBJECTIVE)**

1. (i) since  $\sin 18^\circ = \frac{\sqrt{5}-1}{4}$

$\Rightarrow \cos^2 18^\circ = 1 - \sin^2 18^\circ = 1 - \left[ \frac{6-2\sqrt{5}}{16} \right] = \frac{10+2\sqrt{5}}{16}$

$\Rightarrow \cos 18^\circ = \pm \sqrt{\frac{10+2\sqrt{5}}{16}}$

But  $18^\circ$  lies in I<sup>st</sup> quadrant. Therefore  $\cos 18^\circ$  is positive

$\Rightarrow \cos 18^\circ = \sqrt{\frac{10+2\sqrt{5}}{16}} = \frac{\sqrt{10+2\sqrt{5}}}{4}$

(ii) As we know that  $\sin 2\theta = 2\sin\theta\cos\theta$

$$\Rightarrow \sin(36^\circ) = 2\sin 18^\circ \cos 18^\circ$$

$$\begin{aligned} \Rightarrow \sin 36^\circ &= 2 \times \left( \frac{\sqrt{5}-1}{4} \right) \times \frac{\sqrt{10+2\sqrt{5}}}{4} \\ &= \frac{\sqrt{(\sqrt{5}-1)^2 \cdot (10+2\sqrt{5})}}{8} = \frac{\sqrt{(6-2\sqrt{5})(10+2\sqrt{5})}}{8} \\ &= \frac{\sqrt{10-2\sqrt{5}}}{4} \end{aligned}$$

(iii) As we know that  $\cos^2\theta - \sin^2\theta = \cos(2\theta)$

$$\begin{aligned} \Rightarrow \cos(36^\circ) &= \cos^2(18^\circ) - \sin^2(18^\circ) \\ &= \left( \frac{10+2\sqrt{5}}{16} \right) - \left( \frac{6-2\sqrt{5}}{16} \right) = \frac{\sqrt{5}+1}{4} \end{aligned}$$

2.  $\cos(x-y)$ ,  $\cos x$  and  $\cos(x+y)$  are in H.P. As we know that of  $a$ ,  $b$ ,  $c$  are in H.P., then  $b = \frac{2ac}{a+c}$

$$\therefore \cos x = \frac{2\cos(x+y)\cos(x-y)}{\cos(x+y) + \cos(x-y)}$$

$$\Rightarrow \cos x = \frac{2(\cos^2 x - \sin^2 y)}{2\cos x \cos y}$$

$$\Rightarrow \cos^2 x \cos y = \cos^2 x - \sin^2 y$$

$$\Rightarrow \cos^2 x [1 - \cos y] = \sin^2 y$$

$$\Rightarrow \cos^2 x \cdot 2\sin^2\left(\frac{y}{2}\right) = \left[ 2\sin\left(\frac{y}{2}\right)\cos\left(\frac{y}{2}\right) \right]^2$$

$$\Rightarrow \cos^2 x = 2\cos^2(y/2) \Rightarrow \cos^2 x \sec^2(y/2) = 2$$

$$\Rightarrow |\cos x \sec(y/2)| = \sqrt{2}. \text{ Hence proved.}$$

$$\begin{aligned} 3 \quad \cos \alpha &= \frac{1}{2} \left( x + \frac{1}{x} \right) \Rightarrow 2\cos \alpha = \frac{x^2 + 1}{x} \\ x^2 - 2\cos \alpha x + 1 &= 0 \Rightarrow x = \frac{2\cos \alpha \pm \sqrt{4\cos^2 \alpha - 4}}{2} \end{aligned}$$

$$\Rightarrow x = \frac{2\cos \alpha \pm 2\sin \alpha i}{2} = \cos \alpha \pm i \sin \alpha$$

Similarly  $y = \cos \beta \pm i \sin \beta$

$$\frac{x}{y} = \cos(\alpha - \beta) \pm i \sin(\alpha - \beta) \&$$

$$\frac{y}{x} = \cos(\alpha - \beta) \mp i \sin(\alpha - \beta)$$

Adding we get,  $2 \cos(\alpha - \beta) = x/y + y/x$

4. Let  $\angle QOR = A$

$$\Rightarrow \angle XOR = (B - A)$$

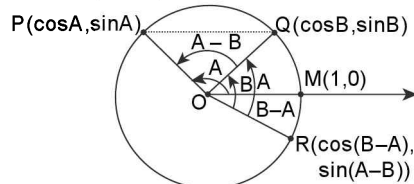

$\Rightarrow$  Coordinates of R are  $(\cos(B - A), \sin(B - A))$

$\therefore \triangle OMR$  and  $\triangle OPQ$  are congruent  $\Delta$ 's

$$\Rightarrow PQ = RM$$

$$\Rightarrow (\cos A - \cos B)^2 + (\sin A - \sin B)^2 = (\cos(B - A) - 1)^2 + (\sin(B - A))^2$$

$$\Rightarrow (\cos^2 A + \sin^2 A) + (\cos^2 B + \sin^2 B) - 2\cos A \cos B - 2\sin A \sin B = \cos^2(B - A) + \sin^2(B - A) + 1 - 2\cos(B - A)$$

$$\Rightarrow 2 - 2[\cos A \cos B + \sin A \sin B] = 2 - 2\cos(B - A)$$

$$\Rightarrow \cos(B - A) = \cos A \cos B + \sin A \sin B$$

$$5. \text{ (a) L.H.S.} = \frac{\sec 8\theta - 1}{\sec 4\theta - 1} = \frac{1 - \cos(8\theta)}{\cos(8\theta)} \times \frac{\cos(4\theta)}{1 - \cos(4\theta)}$$

$$= \frac{2\sin^2(4\theta) \cdot \cos(4\theta)}{\cos(8\theta) \cdot 2\sin^2(2\theta)} = \frac{2\sin(4\theta)\cos(4\theta) \cdot \sin(4\theta)}{\cos(8\theta) \cdot 2\sin^2(2\theta)}$$

$$= \frac{\sin(8\theta)}{\cos(8\theta)} \times \frac{2\sin(2\theta)\cos(2\theta)}{2\sin^2 2\theta \times \sin(2\theta)} = \frac{\tan(8\theta)}{\tan(2\theta)} = \text{RHS}$$

$$\text{(b) L.H.S.} = \frac{\sin^2 \alpha - \sin^2 \beta}{\sin \alpha \cos \alpha - \sin \beta \cos \beta}$$

$$= \frac{2[\sin(\alpha + \beta)\sin(\alpha - \beta)]}{2\sin \alpha \cos \alpha - 2\sin \beta \cos \beta} = \frac{2\sin(\alpha + \beta)\sin(\alpha - \beta)}{\sin(2\alpha) - \sin(2\beta)}$$

$$= \frac{2\sin(\alpha + \beta)\sin(\alpha - \beta)}{2\cos(\alpha + \beta)\sin(\alpha - \beta)} = \tan(\alpha + \beta) = \text{RHS}$$

$$\text{(c) L.H.S.} = \frac{\cos A + \sin A}{\cos A - \sin A} - \frac{\cos A - \sin A}{\cos A + \sin A}$$

$$= \frac{(\cos A + \sin A)^2 - (\cos A - \sin A)^2}{(\cos A - \sin A)(\cos A + \sin A)}$$

$$= \frac{4\cos A \sin A}{\cos^2 A - \sin^2 A} = \frac{2 \cdot \sin(2A)}{\cos(2A)} = 2\tan(2A)$$

$$\text{(d) R.H.S.} = \sin^2(n+1)A - \sin^2(n)A = \sin((n+1)A + nA) \cdot \sin((n+1)A - nA) = \sin((2n+1)A) \cdot \sin(A) = \text{LHS}$$

$$\text{(e) } \tan(3\alpha) = \tan(2\alpha + \alpha) = \frac{\tan(2\alpha) + \tan \alpha}{1 - \tan 2\alpha \cdot \tan \alpha}$$

$$\Rightarrow \tan(3\alpha) - \tan(3\alpha) \tan(2\alpha) \tan \alpha = \tan 2\alpha + \tan \alpha$$

$$\Rightarrow \tan 3\alpha \tan 2\alpha \tan \alpha = \tan(3\alpha) - \tan 2\alpha - \tan \alpha$$

$$6. \text{ (a) L.H.S.} = \sin(4\theta) = \sin(3\theta + \theta) = \sin 3\theta \cos \theta + \cos(3\theta) \sin \theta = \cos \theta [3\sin \theta - 4\sin^3 \theta] + \sin \theta [4\cos^3 \theta - 3\cos \theta] = 4\sin \theta \cos^3 \theta - 4\cos \theta \sin^3 \theta. \text{ R.H.S.}$$

(b) Hint:  $\cos 4\theta = \cos(3\theta + \theta)$

$$7. \text{ L.H.S.} = \left[ 1 + \tan\left(\frac{a}{2}\right) - \sec\left(\frac{a}{2}\right) \right] \left[ 1 + \tan\left(\frac{a}{2}\right) + \sec\left(\frac{a}{2}\right) \right] =$$

$$\left[ 1 + \tan\left(\frac{a}{2}\right) \right]^2 - \sec^2\left(\frac{a}{2}\right)$$

$$= 1 + \tan^2\left(\frac{a}{2}\right) + 2\tan\left(\frac{a}{2}\right) - \sec^2\left(\frac{a}{2}\right)$$

$$= 2\tan\left(\frac{a}{2}\right) = \frac{2\sin\left(\frac{a}{2}\right)\cos\left(\frac{a}{2}\right)}{\cos\left(\frac{a}{2}\right)\cos\left(\frac{a}{2}\right)}$$

$$= \frac{\sin a}{\cos^2\left(\frac{a}{2}\right)} = \sin a \cdot \sec^2\left(\frac{a}{2}\right) = \text{RHS}$$

1.110 > Trigonometry

$$8. (a) \quad 2\sin\left(\frac{A}{2}\right) = \sqrt{1 + \sin A} - \sqrt{1 - \sin A}$$

$$= \left| \sin\left(\frac{A}{2}\right) + \cos\left(\frac{A}{2}\right) \right| - \left| \sin\left(\frac{A}{2}\right) - \cos\left(\frac{A}{2}\right) \right|$$

$$\text{Therefore, } \sin\left(\frac{A}{2}\right) < \cos\left(\frac{A}{2}\right)$$

$$\Rightarrow 2n\pi - \frac{\pi}{4} < \frac{A}{2} < 2n\pi + \frac{\pi}{4}$$

$$(b) \quad 2\cos\left(\frac{A}{2}\right) = \left| \sin\left(\frac{A}{2}\right) + \cos\left(\frac{A}{2}\right) \right| - \left| \sin\frac{A}{2} - \cos\frac{A}{2} \right|$$

$$\text{Here } \sin\left(\frac{A}{2}\right) > \cos\left(\frac{A}{2}\right)$$

$$\Rightarrow 2n\pi + \frac{\pi}{4} < \frac{A}{2} < 2n\pi + \frac{3\pi}{4}$$

**TEXTUAL EXERCISE-12 (SUBJECTIVE)**

$$1. \text{ L.H.S.} = [\sin\alpha + \sin(\alpha/3)] \sin(\alpha/3) + (\cos\alpha - \cos\alpha/3) \cos(\alpha/3)$$

$$= [\sin\alpha \sin(\alpha/3) + \cos\alpha \cos\alpha/3] + \sin^2(\alpha/3) - \cos^2(\alpha/3)$$

$$= \cos\left(\alpha - \frac{\alpha}{3}\right) - \left[ \cos^2\left(\frac{\alpha}{3}\right) - \sin^2\left(\frac{\alpha}{3}\right) \right] = \cos(2\alpha/3) - \cos(2\alpha/3) = 0$$

$$2. \text{ L.H.S.} = \frac{\sin x \sin(2x) + \sin 3x \sin 6x + \sin^4 x \sin 13x}{\sin x \cos(2x) + \sin 3x \cos 6x + \sin 4 \cos 13x}$$

$$= \frac{1}{2} [2 \sin(2x) \sin x + 2 \sin(6x) \sin(3x) + 2 \sin(13x) \sin(4x)]$$

$$= \frac{1}{2} [2 \cos(2x) \sin x + \cos(6x) \sin(3x) + \cos(13x) \sin(4x)]$$

$$= \frac{\cos x - \cos 3x + \cos 3x - \cos 9x + \cos 9x - \cos 17x}{\sin(3x) - \sin x + \sin(9x) - \sin(3x) + \sin(17x) - \sin(9x)}$$

$$= \frac{\cos x - \cos(17x)}{\sin(17x) - \sin x} = \frac{2 \sin(9x) \sin(8x)}{2 \sin(8x) \cos(9x)} = \tan(9x)$$

$$3. \cos\alpha \sin(\beta - \gamma) = \cos\alpha [\sin\beta \cos\gamma - \cos\beta \sin\gamma] = \cos\alpha \sin\beta \cos\gamma - \cos\alpha \cos\beta \sin\gamma$$

$$\text{Similarly } \cot\beta \sin(\gamma - \alpha) = \cos\beta \sin\gamma \cos\alpha - \cos\beta \cos\gamma \sin\alpha$$

$$\text{and } \cos\gamma \sin(\alpha - \beta) = \cos\gamma \sin\alpha \cos\beta - \cos\gamma \cos\alpha \sin\beta$$

$$\text{Adding above all we get, L.H.S.} = 0 = \text{R.H.S.}$$

$$4. \text{ L.H.S.} = \sin(45^\circ + A) \sin(45^\circ - A) = \sin^2(45^\circ) - \sin^2 A$$

$$= \frac{1}{2} - \sin^2 A = \frac{1 - 2\sin^2 A}{2} = \frac{\cos(2A)}{2} = \text{R.H.S.}$$

**TEXTUAL EXERCISE-13 (SUBJECTIVE)**

$$1. \text{ L.H.S.} = 2\cos\left(\frac{A+3B}{2}\right)\cos\left(\frac{3A-B}{2}\right)$$

$$= \cos\left(\frac{A+3B}{2} + \frac{3A-B}{2}\right) + \cos\left(\frac{A+3B}{2} - \frac{3A-B}{2}\right)$$

$$= \cos(2A+B) + \cos(2B-A) = \cos(2A+B) + \cos(A-2B)$$

$$[\because \cos A \cos B = \frac{1}{2} [\cos(A+B) + \cos(A-B)] \text{ and } \cos(-\theta) = \cos\theta]$$

$$2. \text{ L.H.S.} = \sin(A+B) \sin(A-B) = \frac{1}{2} [2\sin(A+B) \sin(A-B)]$$

$$= \frac{1}{2} [\cos[(A+B) - (A-B)] - \cos(A+B+A-B)] = \frac{1}{2} [\cos(2B) - \cos(2A)]$$

$$[\because 2 \sin A \sin B = \cos(A-B) - \cos(A+B)]$$

$$3. (a) \text{ L.H.S.} = \frac{\sin(x+y) + \sin(x-y) - 2\sin x}{\cos(x+y) + \cos(x-y) - 2\cos x}$$

$$= \frac{2\sin x \cos y - 2\sin x}{2\cos x \cos y - 2\cos x}$$

$$= \frac{2\sin x [\cos y - 1]}{2\cos x [\cos y - 1]} = \tan x = \text{R.H.S.}$$

$$(b) \text{ L.H.S.} = \frac{\sin(a+c) + \sin(a-c) + 2\sin a}{\sin(b+c) + \sin(b-c) + 2\sin b}$$

$$= \frac{2\sin a \cos c + 2\sin a}{2\sin b \cos c + 2\sin b} = \frac{\sin a}{\sin b} = \text{R.H.S.}$$

$$(c) \text{ L.H.S.} = \frac{\sin A + \sin B}{\sin A - \sin B} = 2\sin\left(\frac{A+B}{2}\right)\cos\left(\frac{A-B}{2}\right)$$

$$= \tan\left(\frac{A+B}{2}\right)\cot\left(\frac{A-B}{2}\right) = \text{R.H.S.}$$

$$(d) \text{ L.H.S.} = \frac{\cos A + \cos B}{\cos A - \cos B} = \frac{2\cos\left(\frac{A+B}{2}\right)\cos\left(\frac{A-B}{2}\right)}{2\sin\left(\frac{A+B}{2}\right)\sin\left(\frac{B-A}{2}\right)}$$

$$= -\cot\left(\frac{A+B}{2}\right)\cot\left(\frac{A-B}{2}\right)$$

$$(e) \text{ LHS} = [\cos(-B+C+A) + \cos(-A+B+C)] + [\cos(A+B-C) + \cos(A+B+C)]$$

$$= 2\cos C \cdot \cos(A-B) + 2\cos(A+B)\cos C = 2\cos C [\cos(A-B) + \cos(A+B)]$$

$$= 2\cos C \cdot 2\cos A \cos B = 4\cos A \cos B \cos C = \text{R.H.S.}$$

$$4. (a) \text{ L.H.S.} = \cos\left[\theta + \left(n - \frac{3}{2}\right)\phi\right] - \cos\left[\theta + \left(n + \frac{3}{2}\right)\phi\right];$$

[Using  $\cos C - \cos D$ ]

$$\Rightarrow 2\sin\left[\frac{2\theta + \left(n - \frac{3}{2} + n + \frac{3}{2}\right)\phi}{2}\right] \sin\left[\frac{\left(n - \frac{3}{2}\right)\phi - \left(n + \frac{3}{2}\right)\phi}{2}\right]$$

$$= 2\sin(\theta + n\phi) \sin\left(\frac{3\phi}{2}\right)$$

$$(b) \text{ L.H.S.} = \sin\left(\theta + \left(n - \frac{1}{2}\right)\phi\right) + \sin\left(\theta + \left(n + \frac{1}{2}\right)\phi\right)$$

$$\begin{aligned}
 &= 2\sin\left[\frac{\theta + \left(n - \frac{1}{2}\right)\phi + \theta + \left(n + \frac{1}{2}\right)\phi}{2}\right] \\
 &\cos\left[\frac{\theta + \left(n - \frac{1}{2}\right)\phi - \theta - \left(n + \frac{1}{2}\right)\phi}{2}\right] = 2\sin(\theta + n\phi) \\
 &\cos\left(-\frac{\phi}{2}\right) = 2\sin(\theta + n\phi) \cos\left(\frac{\phi}{2}\right) \\
 &\left[\because \sin C + \sin D = 2\sin\left(\frac{C+D}{2}\right)\cos\left(\frac{C-D}{2}\right) \text{ and } \cos(-\theta) = \cos\theta\right]
 \end{aligned}$$

**TEXTUAL EXERCISE-4 (OBJECTIVE)**

1. (c) (a)  $\sin 15^\circ = \frac{\sqrt{3}-1}{2\sqrt{2}}$  (Irrational)
- (b)  $\cos 15^\circ = \frac{\sqrt{3}+1}{2\sqrt{2}}$  (Irrational)
- (c)  $\sin 15^\circ \cos 15^\circ = 1/2 \cdot 2\sin 15^\circ \cos 15^\circ = 1/2 \cdot \sin 30^\circ = 1/4 = \text{rational}$
- (d)  $\sin 15^\circ \cos 75^\circ = 1/2 \cdot 2\sin 15^\circ \cos 75^\circ = \frac{1}{2}[\sin 90^\circ + \sin(-60^\circ)] = \frac{1}{2}\left[1 - \frac{\sqrt{3}}{2}\right] = \text{irrational}$
2. (b)  $\frac{1 + \sin\theta - \cos\theta}{1 + \sin\theta + \cos\theta} = \frac{(1 - \cos\theta) + \sin\theta}{(1 + \cos\theta) + \sin\theta}$
- $$= \frac{2\sin^2(\theta/2) + 2\sin(\theta/2)\cos(\theta/2)}{2\cos^2(\theta/2) + 2\sin(\theta/2)\cos(\theta/2)} = \tan(\theta/2)$$
3. (d)  $\sin\alpha = \sqrt{1 - \frac{9}{25}} = \frac{4}{25}$ ,  $\sin\beta = \frac{3}{5}$   $\therefore \cos(\alpha - \beta)$
- $$= \cos\alpha + \cos\beta + \sin\alpha \sin\beta = \frac{3}{5} \times \frac{4}{5} + \frac{4}{5} \times \frac{3}{5} = \frac{24}{25}$$
- Now  $1 + \cos(\alpha - \beta) = 2\cos^2\left(\frac{\alpha - \beta}{2}\right)$
- $$\left[ \begin{array}{l} 0 < \alpha < \frac{\pi}{2} \\ 0 < \beta < \frac{\pi}{2} \\ -\frac{\pi}{4} < \frac{\alpha - \beta}{2} < \frac{\pi}{4} \\ \therefore \cos\left(\frac{\alpha - \beta}{2}\right) = \frac{7}{5\sqrt{2}} \end{array} \right]$$
- $$\Rightarrow \frac{1 + \frac{24}{25}}{2} = \cos^2\left(\frac{\alpha - \beta}{2}\right)$$
- $$\Rightarrow \cos^2\left(\frac{\alpha - \beta}{2}\right) = \frac{49}{50} \Rightarrow \cos\left(\frac{\alpha - \beta}{2}\right) = \frac{7}{5\sqrt{2}}$$

4. (a)  $\tan\theta = \frac{1}{\sqrt{3}}$ . Now  $\sqrt{3}\cos(2\theta) + \sin 2\theta$

$$= \sqrt{3}\left[\frac{1 - \tan^2\theta}{1 + \tan^2\theta}\right] + \frac{2\tan\theta}{1 + \tan^2\theta}$$

$$= \sqrt{3}\left[\frac{1 - \frac{1}{3}}{1 + \frac{1}{3}}\right] + \frac{2 \cdot \frac{1}{\sqrt{3}}}{1 + \frac{1}{3}} = \sqrt{3} \times \frac{1}{2} + \frac{2}{\sqrt{3}} \times \frac{3}{4} = \frac{\sqrt{3}}{2} + \frac{\sqrt{3}}{2} = \sqrt{3}$$

[*Aliter:*  $\tan\theta = 1/\sqrt{3} \Rightarrow \theta$  may be taken as  $30^\circ$ ]

5. (a)  $\cos\left(\frac{\pi}{13}\right) + \cos\left(\frac{2\pi}{13}\right) + \cos\left(\frac{3\pi}{13}\right) + \dots + \cos\left(\frac{12\pi}{13}\right)$

Now  $\cos\left(\frac{12\pi}{13}\right) = \cos\left(\pi - \frac{\pi}{13}\right) = -\cos\left(\frac{\pi}{13}\right)$

$\cos\left(\frac{11\pi}{13}\right) = -\cos\left(\frac{2\pi}{13}\right)$  and so on ....

$\cos\left(\frac{7\pi}{13}\right) = -\cos\left(\frac{6\pi}{13}\right)$ . Therefore L.H.S. = 0

6. (a)  $\frac{1}{\tan 3A - \tan A} - \frac{1}{\cot 3A - \cot A}$

$$= \frac{1}{\tan 3A - \tan A} - \frac{1}{\frac{1}{\tan 3A} - \frac{1}{\tan A}}$$

$$= \frac{1}{\tan 3A - \tan A} + \frac{\tan 3A \tan A}{\tan 3A - \tan A}$$

$$= \frac{1 + \tan 3A \tan A}{\tan 3A - \tan A} = \frac{1}{\tan^2 A} = \cot(2A)$$

7. (b) In a  $\Delta$ ,  $A = \pi - (B + C) \Rightarrow \sin A = \sin(B + C)$

$\therefore \sin A \sin(B - C)$

$$= \sin(B + C) \sin(B - C) = \sin^2 B - \sin^2 C$$

$\therefore \Sigma \sin A \sin(B - C) = \sin^2 B - \sin^2 C + \sin^2 C - \sin^2 A + \sin^2 A - \sin^2 B = 0$

8. (c)  $\tan A = 2\tan B + \cot B$

$$\Rightarrow \tan A \tan B = 2\tan^2 B + 1 \quad \dots(i)$$

Also  $\tan A \tan B - \tan^2 B = 1 + \tan^2 B$

$$\Rightarrow 1 + \tan^2 B = \tan B [\tan A - \tan B] \quad \dots(ii)$$

Now  $2\tan(A - B) = \frac{2(\tan A - \tan B)}{1 + \tan A \tan B} = \frac{2[\tan A - \tan B]}{1 + 1 + 2\tan^2 B}$

[ $\because$  using (i)]

$$= \frac{\tan A - \tan B}{1 + \tan^2 B} = \frac{1}{\tan B} = \cot B \quad [\text{using (ii)}]$$

9. (a)  $\sin A = \sin B$  and  $\cos A = \cos B$

$$\Rightarrow \sin A - \sin B = 0 \text{ and } \cos A - \cos B = 0$$

$$\Rightarrow 2\cos\left(\frac{A+B}{2}\right)\sin\left(\frac{A-B}{2}\right) = 0 \quad \dots(i)$$

And  $-2\sin\left(\frac{A+B}{2}\right)\sin\left(\frac{A-B}{2}\right) = 0 \quad \dots(ii)$

Both (i) and (ii) are satisfied if  $\sin\left(\frac{A-B}{2}\right) = 0$ .



1.112 > Trigonometry

10. (b)  $\cos^2(48^\circ) - \sin^2(12^\circ) = \cos(48^\circ + 12^\circ) \cos(48^\circ - 12^\circ) = \cos 60^\circ \cdot \cos 36^\circ = \frac{1}{2} \cdot \frac{\sqrt{5}+1}{4} = \frac{\sqrt{5}+1}{8}$

11. (b)  $\sin 75^\circ = \sin(45^\circ + 30^\circ) = \sin 45^\circ \cos 30^\circ + \cos 45^\circ \sin 30^\circ = \frac{\sqrt{3}+1}{2\sqrt{2}}$

12. (a)  $\cos 15^\circ - \sin 15^\circ = \sin 75^\circ - \sin 15^\circ = 2 \cos(45^\circ) \sin(30^\circ) = 2 \times \frac{1}{\sqrt{2}} \times \frac{1}{2} = \frac{1}{\sqrt{2}}$

13. (b)  $\tan \alpha = \frac{1}{1+2^{-x}} = \frac{2^x}{1+2^x} = \frac{t}{1+t}$   
 $\tan \beta = \frac{1}{1+2^{x+1}} = \frac{1}{1+2t}$ , where  $t = 2^x$   
 Now  $\tan(\alpha + \beta) = \frac{\tan \alpha + \tan \beta}{1 - \tan \alpha \cdot \tan \beta} = \frac{\frac{t}{1+t} + \frac{1}{1+2t}}{1 - \frac{t}{1+t} \cdot \frac{1}{1+2t}} = 1 \Rightarrow \alpha + \beta = \pi/4$

14. (a)  $\cos A = m \cos B \Rightarrow \frac{\cos A}{\cos B} = \frac{m}{1}$   
 Applying componendo and dividendo, we get,

$$\frac{\cos A + \cos B}{\cos A - \cos B} = \frac{m+1}{m-1}$$

$$\Rightarrow \frac{2 \cos\left(\frac{A+B}{2}\right) \cos\left(\frac{A-B}{2}\right)}{-2 \sin\left(\frac{A+B}{2}\right) \sin\left(\frac{A-B}{2}\right)} = \frac{m+1}{m-1}$$

$$\Rightarrow \cot\left(\frac{A+B}{2}\right) = \frac{m+1}{m-1} \cdot \frac{\sin\left(\frac{B-A}{2}\right)}{\cos\left(\frac{B-A}{2}\right)}$$

$$\Rightarrow \cot\left(\frac{A+B}{2}\right) = \frac{m+1}{m-1} \cdot \tan\left(\frac{B-A}{2}\right)$$

15. (a)  $\cos^2\left(\frac{\pi}{6} + \theta\right) - \sin^2\left(\frac{\pi}{6} - \theta\right) = \cos\left(\frac{\pi}{3}\right) \cos(2\theta) = \frac{1}{2} \cos(2\theta)$

[ $\because \cos^2 A - \sin^2 B = \cos(A+B) \cos(A-B)$ ]

16. (b)  $\frac{\sin(x+y)}{\sin(x-y)} = \frac{a+b}{a-b}$ , Applying componendo and dividendo, we get  $\frac{\sin(x+y) + \sin(x-y)}{\sin(x+y) - \sin(x-y)} = \frac{2a}{2b}$   
 $\Rightarrow \frac{2 \sin x \cos y}{2 \cos x \sin y} = \frac{a}{b} \Rightarrow \frac{\tan x}{\tan y} = \frac{a}{b}$

17. (d)  $\tan A = \frac{3}{2}$  (given)  
 $\Rightarrow \frac{1 + \cos A}{1 - \cos A} = \frac{2 \cos^2\left(\frac{A}{2}\right)}{2 \sin^2\left(\frac{A}{2}\right)} = \cot^2\left(\frac{A}{2}\right) = \frac{4}{9}$

18. (a)  $\frac{\sin(2A)}{1 + \cos(2A)} \cdot \frac{\cos A}{1 + \cos A} = \frac{2 \sin A \cos A}{2 \cos^2 A} \cdot \frac{\cos A}{1 + \cos A}$   
 $= \frac{\sin A}{1 + \cos A} = \frac{2 \sin(A/2) \cos(A/2)}{2 \cos^2(A/2)} = \tan\left(\frac{A}{2}\right)$

TEXTUAL EXERCISE-14 (SUBJECTIVE)

1.  $A + B + C = \pi$

L.H.S. =  $\cos 2A + \cos 2B + \cos 2C = 2 \cos(A+B) \cos(A-B) + \cos(2C) = -2 \cos C \cos(A-B) + 2 \cos^2 C - 1 = 2 \cos C [\cos C - \cos(A-B)] - 1 = 2 \cos C [-\cos(A+B) - \cos(A-B)] - 1 = -1 - 2 \cos C [\cos(A+B) + \cos(A-B)] = -1 - 2 \cos C \cdot [2 \cos A \cos B] = -1 - 4 \cos A \cos B \cos C = -1 - 4 \Pi \cos A$

Hence  $\Sigma \cos(2A) = -1 - 4 \Pi \cos A$

2. (i) we have  $\tan A + \tan B + \tan C = \tan A \tan B \tan C$

Dividing both sides by  $\tan A \tan B \tan C$ , we get  $\cot B \cot C + \cot A \cot C + \cot A \cot B = 1$

(ii) we have  $\cot\left(\frac{A}{2}\right) + \cot\left(\frac{B}{2}\right) + \cot\left(\frac{C}{2}\right) = \cot\left(\frac{A}{2}\right) \cot\left(\frac{B}{2}\right) \cot\left(\frac{C}{2}\right)$

Dividing both side by  $\cot(A/2) + \cot(B/2) \cot(C/2)$ , we get

$\tan(B/2) \tan(C/2) + \tan(C/2) \tan(A/2) + \tan(A/2) \tan(B/2) = 1$ . Hence proved

3. L.H.S. =  $\cos A + \cos B - \cos C$

$$= 2 \cos\left(\frac{A+B}{2}\right) \cos\left(\frac{A-B}{2}\right) - \cos C$$

$$= 2 \sin\left(\frac{C}{2}\right) \cos\left(\frac{A-B}{2}\right) - \left[1 - 2 \sin^2\left(\frac{C}{2}\right)\right]$$

$$= -1 + 2 \sin\left(\frac{C}{2}\right) \left[\cos\left(\frac{A-B}{2}\right) + \sin\left(\frac{C}{2}\right)\right]$$

$$= -1 + 2 \sin\left(\frac{C}{2}\right) \left[\cos\left(\frac{A-B}{2}\right) + \cos\left(\frac{A+B}{2}\right)\right]$$

$$= -1 + 2 \sin\left(\frac{C}{2}\right) \left[2 \cos\left(\frac{A}{2}\right) \cos\left(\frac{B}{2}\right)\right]$$

$$= -1 + 4 \cos\left(\frac{A}{2}\right) \cos\left(\frac{B}{2}\right) \sin\left(\frac{C}{2}\right)$$
. Hence proved

4. (a) L.H.S. =  $\sin^2 A + \sin^2 B + \sin^2 C$

$$= \frac{1}{2} [1 - \cos 2A + 1 - \cos 2B + 1 - \cos 2C]$$

$$= \frac{1}{2} [3 - [\cos 2A + \cos 2B + \cos 2C]]$$

$$= \frac{1}{2} [3 - [-1 - 4 \cos A \cos B \cos C]] = 2 + 2 \cos A \cos B \cos C = \text{R.H.S.}$$

[Refer no (1)]

$$\begin{aligned}
 \text{(b) LHS} &= \cos^2 A + \cos^2 B - \cos^2 C = 1/2[1 + \cos 2A + 1 + \cos 2B] - \cos^2 C \\
 &= 1 + 1/2 \cdot 2\cos(A+B)\cos(A-B) - \cos^2 C \\
 \cos^2 C &= 1 + \cos(A+B)\cos(A-B) - \cos^2 C = 1 - \cos C [\cos(A-B) + \cos C] \\
 \cos(A-B) - \cos^2 C &= 1 - \cos C [\cos(A-B) + \cos C] = 1 - \cos C [\cos(A-B) - \cos(A+B)] = 1 - \cos C \cdot 2\sin A \sin B \\
 \sin B &= 1 - 2\sin A \sin B \cos C
 \end{aligned}$$

$$\begin{aligned}
 \text{5. (a) L.H.S.} &= \cos\left(\frac{A}{2}\right) + \cos\left(\frac{B}{2}\right) + \cos\left(\frac{C}{2}\right) \\
 &= 2\cos\left(\frac{\frac{A+B}{2}}{2}\right)\cos\left(\frac{\frac{A-B}{2}}{2}\right) + \cos\left(\frac{C}{2}\right) \\
 &= 2\cos\left(\frac{A+B}{4}\right)\cos\left(\frac{A-B}{4}\right) + \cos\left(\frac{C}{2}\right) \\
 &= 2\cos\left(\frac{\pi-C}{4}\right)\cos\left(\frac{A-B}{4}\right) + \cos\left(\frac{C}{2}\right) \\
 &= 2\cos\left(\frac{\pi-C}{4}\right)\cos\left(\frac{A-B}{4}\right) + \cos\left(\frac{C}{2}\right) + \cos\left(\frac{\pi}{2}\right) \\
 &= 2\cos\left(\frac{\pi-C}{4}\right)\cos\left(\frac{A-B}{4}\right) + 2\cos\left(\frac{\pi+C}{4}\right)\cos\left(\frac{\pi-C}{4}\right) \\
 &= 2\cos\left(\frac{\pi-C}{4}\right)\left[\cos\left(\frac{A-B}{4}\right) + \cos\left(\frac{\pi+C}{4}\right)\right] \\
 &= 2\cos\left(\frac{\pi-C}{4}\right)\cos\left(\frac{\pi+C+A-B}{8}\right) \\
 &\quad \cos\left(\frac{\pi+C-A+B}{8}\right) \\
 &= 4\cos\left(\frac{\pi-C}{4}\right)\cos\left(\frac{\pi-B}{4}\right)\cos\left(\frac{\pi-A}{4}\right).
 \end{aligned}$$

Hence proved  $[\because \pi - B = A + C \text{ and } \pi - A = B + C]$

$$\begin{aligned}
 \text{(b) R.H.S.} &= 1 + 4 \sin\left(\frac{\pi-A}{4}\right)\sin\left(\frac{\pi-B}{4}\right)\sin\left(\frac{\pi-C}{4}\right) \\
 &= 1 + 2\sin\left(\frac{\pi-A}{4}\right)2\sin\left(\frac{\pi-B}{4}\right)\sin\left(\frac{\pi-C}{4}\right) \\
 &= 1 + 2\sin\left(\frac{\pi-A}{4}\right) \\
 &\quad \left[\cos\left(\frac{\pi-B}{4}\right) - \left(\frac{\pi-C}{4}\right) - \cos\left(\frac{\pi-B}{4} + \frac{\pi-C}{4}\right)\right] \\
 &= 1 + 2\sin\left(\frac{\pi-A}{4}\right)\left[\cos\left(\frac{C-B}{4}\right) - \cos\left(\frac{\pi}{2} - \left(\frac{B+C}{4}\right)\right)\right] \\
 &= 1 + 2\sin\left(\frac{\pi-A}{4}\right)\left[\cos\left(\frac{B-C}{4}\right) - \sin\left(\frac{B+C}{4}\right)\right] \\
 &= 1 + 2\sin\left(\frac{\pi-A}{4}\right)\cos\left(\frac{B-C}{4}\right) - 2\sin\left(\frac{\pi-A}{4}\right)\sin\left(\frac{B+C}{4}\right) \\
 &= 1 + \left[\sin\left(\frac{\pi+B-(A+C)}{4}\right) + \sin\left(\frac{\pi-A-B+C}{4}\right)\right] \\
 &\quad - \left[\cos\left(\frac{\pi-A-B-C}{4}\right) - \cos\left(\frac{\pi+B+C-A}{4}\right)\right]
 \end{aligned}$$

$$\begin{aligned}
 &= 1 + \sin\left(\frac{[\pi-(A+C)]+B}{4}\right) + \sin\left(\frac{[\pi-(A+B)]+C}{4}\right) \\
 &\quad - \left[\cos\left(\frac{\pi-(A+B+C)}{4}\right) - \cos\left(\frac{(\pi-A)+(B+C)}{4}\right)\right] \\
 &= 1 + \sin\left(\frac{B}{2}\right) + \sin\left(\frac{C}{2}\right) - 1 + \cos\left(\frac{B+C}{2}\right) \\
 &= \sin(B/2) + \sin(C/2) + \cos(\pi-A)/2 \\
 &= \sin(B/2) + \sin(C/2) + \sin(A/2) = \text{L.H.S.} \\
 &[\because \pi-(A+C)=B, \pi-(A+B)=C, \cos\left(\frac{\pi}{2}-\frac{A}{2}\right)=\sin\left(\frac{A}{2}\right)]
 \end{aligned}$$

$$\begin{aligned}
 \text{6. } \frac{\cot A \cot B}{\tan A + \tan B} &= \frac{1}{\tan A} + \frac{1}{\tan B} = \frac{1}{\tan A \tan B} = \cot A \cot B \\
 \Rightarrow \text{L.H.S.} &= \cot A \cot B + \cot B \cot C + \cot C \cot B \\
 \text{Now } A + B + C &= \pi \Rightarrow A + B = \pi - C \\
 \Rightarrow \cot(A+B) &= \cot(\pi - C) = -\cot C \\
 \Rightarrow \frac{\cot A \cot B - 1}{\cot B \cot A} &= -\cot C \\
 \Rightarrow \cot A \cot B + \cot B \cot C + \cot A \cot C &= 1. \text{ Hence LHS} \\
 &= \text{RHS}
 \end{aligned}$$

$$\begin{aligned}
 \text{7. Let } A = x - y, B = y - z, C = z - x \\
 \Rightarrow A + B + C &= 0 \quad \Rightarrow A + B = -C \\
 \Rightarrow \tan(A+B) &= -\tan C \Rightarrow \frac{\tan A + \tan B}{1 - \tan A \tan B} = -\tan C \\
 \Rightarrow \tan A + \tan B + \tan C &= \tan A \tan B \tan C \\
 \text{Hence } \tan(x-y) + \tan(y-z) + \tan(z-x) &= \tan(x-y) \\
 \tan(y-z) \tan(z-x) &= \text{R.H.S.}
 \end{aligned}$$

$$\begin{aligned}
 \text{8. (a) } A + B + C &= \pi \\
 \text{Now } \cos A &= \cos(\pi - (B+C)) = -\cos(B+C) \\
 &= -[\cos B \cos C - \sin B \sin C] = \sin B \sin C - \cos B \cos C \\
 \Rightarrow \frac{\cos A}{\sin B \sin C} &= 1 - \cot B \cot C \\
 \text{Hence, L.H.S.} &= (1 - \cot B \cot C) + (1 - \cot C \cot A) + (1 - \cot A \cot B) \\
 &= 3 - [\cot A \cot B + \cot B \cot C + \cot C \cot A] = 3 - 1 = 2 \\
 &= \text{RHS}
 \end{aligned}$$

$$\begin{aligned}
 \text{(b) L.H.S.} &= \sin(B+C-A) = \sin(\pi - 2A) = \sin 2A \\
 \therefore \text{L.H.S.} &= \sin(2A) + \sin(2B) - \sin(2C) \\
 &= 2\sin(A+B)\cos(A-B) - 2\sin C \cos C = 2\sin(\pi - C) \\
 &\quad \cos(A-B) - 2\sin C \cos C \\
 &= 2\sin C [\cos(A-B) - \cos C] = 2\sin C [\cos(A-B) + \cos(A+B)] \\
 &= 2\sin C \cdot 2\cos(A)\cos(B) = 4\cos A \cos B \sin C = \text{R.H.S.}
 \end{aligned}$$

#### TEXTUAL EXERCISE-5 (OBJECTIVE)

$$\begin{aligned}
 \text{1. (a) } A + B + C &= (2n+1)\pi \\
 \Rightarrow A + B &= [(2n+1)\pi - C] \\
 \Rightarrow \tan(A+B) &= -\tan C
 \end{aligned}$$

1.114 > Trigonometry

$$\Rightarrow \frac{\tan A + \tan B}{1 - \tan A \tan B} = -\tan C$$

$$\Rightarrow \tan A + \tan B + \tan C = \tan A \tan B \tan C$$

2. (c) L.H.S. =  $\sin^2\alpha + \sin^2\beta - \sin^2\gamma$

$$= \frac{1 - \cos 2\alpha}{2} + \frac{1 - \cos 2\beta}{2} - \left[ \frac{1 - \cos 2\gamma}{2} \right]$$

$$= \frac{1}{2} - \frac{1}{2} [\cos(2\alpha) + \cos(2\beta) - \cos(2\gamma)]$$

$$= \frac{1}{2} - \frac{1}{2} [-2\cos(\gamma)\cos(\alpha - \beta) - [2\cos^2\gamma - 1]]$$

$$= \frac{1}{2} + \cos\gamma\cos(\alpha - \beta) + \cos^2\gamma - \frac{1}{2}$$

$$= \cos\gamma [\cos(\alpha - \beta) + \cos\gamma] = \cos\gamma [\cos(\alpha - \beta) - \cos(\alpha + \beta)] = \cos(\gamma) \cdot 2\sin(\alpha)\sin(\beta) = 2\sin\alpha\sin\beta\sin\gamma.$$

3. (d)  $\angle A + \angle C = 180^\circ, \angle B + \angle D = 180^\circ$   
 $\cos A = \cos(180^\circ - C) = -\cos C$   
 Similarly  $\cos B = -\cos D$   
 $\Rightarrow \cos A + \cos B + \cos C + \cos D = 0$

4. (b)  $\sin A + \sin B + \sin C$

$$= 2\sin\left(\frac{A+B}{2}\right)\cos\left(\frac{A-B}{2}\right) + 2\sin\left(\frac{C}{2}\right)\cos\left(\frac{C}{2}\right)$$

$$= 2\cos\left(\frac{C}{2}\right)\left[\cos\left(\frac{A-B}{2}\right) + \sin\left(\frac{C}{2}\right)\right]$$

$$= 2\cos\left(\frac{C}{2}\right)\left[\cos\left(\frac{A-B}{2}\right) + \cos\left(\frac{A+B}{2}\right)\right]$$

$$= 2\cos\left(\frac{C}{2}\right) \cdot 2\cos\left(\frac{A}{2}\right)\cos\left(\frac{B}{2}\right)$$

$$= 4\cos\left(\frac{A}{2}\right)\cos\left(\frac{B}{2}\right)\cos\left(\frac{C}{2}\right)$$

5. (b)  $\tan A + \tan B + \tan C = 6$  ..... (i)  
 $\tan A \tan B = 2$  ..... (ii)  
 We know that in a triangle  $\tan A + \tan B + \tan C = \tan A \cdot \tan B \cdot \tan C$   
 $\Rightarrow 6 = 2\tan C \Rightarrow \tan C = 3$   
 Also from equation (i),  $\tan A + \tan B = 3$  ..... (iii)  
 Now solving (ii) and (iii), we get  $\tan A \cdot \tan B$

6. (b)  $\cot B + \cot C = \frac{\cos B}{\sin B} + \frac{\cos C}{\sin C} = \frac{\cos B \sin C + \sin B \cos C}{\sin B \sin C}$

$$= \frac{\sin(C+B)}{\sin B \sin C} = \frac{\sin(\pi - A)}{\sin B \sin C} = \frac{\sin A}{\sin B \sin C}$$

Similarly  $\cot C + \cot A = \frac{\sin B}{\sin C \sin A}$  and

$$\cot A + \cot B = \frac{\sin C}{\sin A \sin B}$$

$\therefore$  L.H.S. =  $\operatorname{cosec} A \operatorname{cosec} B \operatorname{cosec} C$

7. (b)  $A + B + C = \pi \Rightarrow C = (\pi - (A + B))$   
 $\Rightarrow \tan C = -\tan(A + B) \Rightarrow \tan C = \frac{\tan A + \tan B}{\tan A \tan B - 1}$

Now C is obtuse  $\Rightarrow \tan C < 0$   
 $\Rightarrow \tan A \tan B - 1 < 0 \Rightarrow \tan A \tan B < 1$

**TEXTUAL EXERCISE-15 (SUBJECTIVE)**

1. (i)  $ax + by = c$  ..... (i)  
 $bx - ay = d$  ..... (ii)  
 $x^2 + y^2 = 1$  ..... (iii)  
 Squaring and adding (1) and (2), we get  $a^2x^2 + b^2y^2 + 2bxy + b^2x^2 + a^2y^2 - 2abxy = c^2 + d^2$   
 $\Rightarrow (a^2 + b^2)x^2 + (b^2 + a^2)y^2 = c^2 + d^2$   
 $\Rightarrow (a^2 + b^2)(x^2 + y^2) = c^2 + d^2$   
 $\Rightarrow (a^2 + b^2) \cdot 1 = c^2 + d^2$  [using (iii)]  
 Hence  $a^2 + b^2 = c^2 + d^2$

(ii)  $ax + by = c$  ..... (i)  
 $bx + ay = d$  ..... (ii)  
 $x^2 - y^2 = r^2$  ..... (iii)  
 Squaring and subtracting (i) and (ii), we get  $(a^2x^2 + b^2y^2 + 2abxy) - (b^2x^2 + a^2y^2 + 2abxy) = c^2 - d^2$   
 $\Rightarrow (a^2 - b^2)x^2 + y^2(b^2 - a^2) = c^2 - d^2$   
 $\Rightarrow (a^2 - b^2)(x^2 - y^2) = c^2 - d^2$   
 $\Rightarrow (a^2 - b^2)r^2 = c^2 - d^2$

2. (i)  $\sin\theta + \cos\theta = m$  ..... (i)  
 $\sin\theta \cos\theta = \frac{m}{n}$  ..... (ii)  
 Squaring both sides of equation (i), we get  $\sin^2\theta + \cos^2\theta + 2\sin\theta \cos\theta = m^2$   
 $\Rightarrow \sin\theta \cos\theta = \frac{m^2 - 1}{2} \Rightarrow \frac{m}{n} = \frac{m^2 - 1}{2}$  [using (ii)]  
 $\Rightarrow 2m = n[m^2 - 1] \Rightarrow 2m + n = nm^2$   
 (ii)  $\sec\theta - \tan\theta = a$  ..... (i)  
 and  $\sec\theta \tan\theta = b$  ..... (ii)

We know parallel  $\sec\theta + \tan\theta = \frac{1}{\sec\theta - \tan\theta}$   
 $\Rightarrow \sec\theta + \tan\theta = 1/a$  ..... (iii)

Adding (i) and (iii), we get  $\sec\theta = \frac{a + \frac{1}{a}}{2} = \frac{a^2 + 1}{2a}$   
 Subtracting (iii) - (i), we get  $2\tan\theta = \frac{\frac{1}{a} - a}{2} = \frac{1 - a^2}{2a}$

Now from (ii),  $\sec\theta \tan\theta = b$   
 $\Rightarrow \left(\frac{a^2 + 1}{2a}\right) \times \left(\frac{1 - a^2}{2a}\right) = b$   
 $\Rightarrow (1 - a^4) = 4a^2b$   
 $\Rightarrow 1 = a^4 + 4a^2b \Rightarrow 1 = a\sqrt{a^2 + 4b}$

3. (a)  $\sin\theta - \cos\theta = p$  ..... (i)  
 $\operatorname{cosec}\theta - \sin\theta = q$  ..... (ii)  
 Squaring both sides of (i), we get  $1 - 2\sin\theta \cos\theta = p^2$   
 $\Rightarrow 2\sin\theta \cos\theta = 1 - p^2$  ..... (iii)  
 Also  $\sin^2\theta + \cos^2\theta = 1$

$$\begin{aligned} \Rightarrow (\sin\theta + \cos\theta)^2 - 2\sin\theta \cos\theta &= 1 \\ \Rightarrow (\sin\theta + \cos\theta)^2 &= 1 + 1 - p^2 \quad [\text{using (iii)}] \\ \Rightarrow \sin\theta + \cos\theta &= \pm\sqrt{2-p^2} \quad \dots \text{(iv)} \end{aligned}$$

Now adding (i) and (iv), we get  $2\sin\theta = p \pm \sqrt{2-p^2}$

$$\Rightarrow \sin\theta = \frac{p \pm \sqrt{2-p^2}}{2} \quad \dots \text{(v)}$$

$$\text{Also (iv) - (i) gives, } \cos\theta = \frac{\pm\sqrt{2-p^2} - p}{2} \quad \dots \text{(vi)}$$

$$\text{From (ii), we get } \frac{\cos^2\theta}{\sin\theta} = q$$

$$\Rightarrow \cos^2\theta = q \sin\theta$$

Using (v) and (vi), we get

$$\left( \frac{\pm\sqrt{2-p^2} - p}{2} \right)^2 = \frac{q \left( \pm\sqrt{2-p^2} + p \right)}{2}$$

$$\text{(b) } a \cos\theta + b \sin\theta = c \quad \dots \text{(i)}$$

$$a \sin\theta - b \cos\theta = d \quad \dots \text{(ii)}$$

Squaring and adding equation (i) and (ii), we get  $a^2$

$$\cos^2\theta + b^2 \sin^2\theta + a^2 \sin^2\theta + b^2 \cos^2\theta = c^2 + d^2$$

$$\Rightarrow (a^2 + b^2) (\cos^2\theta + \sin^2\theta) = c^2 + d^2$$

$$\Rightarrow a^2 + b^2 = c^2 + d^2$$

$$\text{(c) } a \cos(\theta + \alpha) = x \quad \dots \text{(i)}$$

$$b \cos(\theta - \beta) = y \quad \dots \text{(ii)}$$

We can write  $\cos(\alpha + \beta) = \cos[(\theta + \alpha) - (\theta - \beta)]$

$$= \cos(\theta + \alpha) \cos(\theta - \beta) + \sin(\theta + \alpha) \sin(\theta - \beta)$$

$$\Rightarrow \cos(\alpha + \beta) = \frac{x}{a} \cdot \frac{y}{b} + \sqrt{1 - \frac{x^2}{a^2}} \cdot \sqrt{1 - \frac{y^2}{b^2}}$$

[using equation (i) and (ii)]

$$\Rightarrow \cos(\alpha + \beta) = \frac{xy}{ab} + \frac{1}{ab} \sqrt{a^2 - x^2} \cdot \sqrt{b^2 - y^2}$$

$$\text{(d) } x \cos\theta - y \sin\theta = \cos(2\theta) \quad \dots \text{(i)}$$

$$\text{and } x \sin\theta + y \cos\theta = \sin(2\theta) \quad \dots \text{(ii)}$$

Squaring and adding we get,  $x^2 (\cos^2\theta + \sin^2\theta) + y^2 (\sin^2\theta + \cos^2\theta) = \cos^2 2\theta + \sin^2 2\theta$

$$\Rightarrow x^2 + y^2 = 1$$

$$\text{(e) } \sin\theta - \cos\theta = p$$

$$\text{cosec}\theta - \sec\theta = q$$

$$p^2 = 1 - 2\sin\theta \cos\theta \quad \dots \text{(i)}$$

$$\text{Also } q = \frac{1}{\sin\theta} - \frac{1}{\cos\theta} = \frac{\cos\theta - \sin\theta}{\sin\theta \cos\theta} \quad \dots \text{(ii)}$$

$$\therefore \text{ From (i) and (ii) we get, } q = \frac{\cos\theta - \sin\theta}{\left( \frac{1-p^2}{2} \right)}$$

$$\Rightarrow q = \frac{-p}{\left( \frac{1-p^2}{2} \right)} = \frac{2p}{p^2 - 1}$$

$$\Rightarrow p^2 q - q = 2p$$

$$\Rightarrow p^2 q = q + 2p$$

$$4. m = \text{cosec}\theta - \sin\theta$$

$$\Rightarrow m = \frac{1 - \sin^2\theta}{\sin\theta} = \frac{\cos^2\theta}{\sin\theta} \quad \dots \text{(i)}$$

$$\text{Also } \sec\theta - \cos\theta = n \Rightarrow \frac{1 - \cos^2\theta}{\cos\theta} = n$$

$$\Rightarrow \frac{\sin^2\theta}{\cos\theta} = n \quad \dots \text{(ii)}$$

From (i) and (ii), we have  $m^2 \cdot n = \cos^3\theta$  and  $n^2 m = \sin^3\theta$

$$\Rightarrow \cos\theta = m^{\frac{2}{3}} \cdot n^{\frac{1}{3}} \text{ \& } \sin\theta = n^{\frac{2}{3}} \cdot m^{\frac{1}{3}}$$

Now we have  $\sin^2\theta + \cos^2\theta = 1$

$$\Rightarrow m^{\frac{4}{3}} \cdot n^{\frac{2}{3}} + m^{\frac{2}{3}} \cdot n^{\frac{4}{3}} = 1 \Rightarrow (mn)^{2/3} [m^{2/3} + n^{2/3}] = 1$$

$$\Rightarrow m^{2/3} + n^{2/3} = mn^{-2/3}$$

$$5. \cos^2\theta + \cos^2(\alpha + \theta) - 2\cos\alpha \cos\theta \cos(\alpha + \theta)$$

$$= \frac{1 + \cos 2\theta}{2} + \frac{1 + \cos(2(\alpha + \theta))}{2} - 2\cos\alpha \cos\theta \cos(\alpha + \theta)$$

$$= 1 + 1/2 [\cos(2\theta) + \cos(2\alpha + 2\theta)] - 2\cos\alpha \cos\theta \cos(\alpha + \theta)$$

$$= 1 + 1/2 [2 \cdot \cos(\alpha + \theta) \cos\alpha] - 2\cos\alpha \cos\theta \cos(\alpha + \theta)$$

$$= 1 + \cos\alpha [\cos(\alpha + \theta) - 2\cos(\alpha + \theta) \cos\theta]$$

$$= 1 + \cos\alpha [\cos(\alpha + 2\theta) - (\cos(\alpha + 2\theta) + \cos\alpha)]$$

$$= 1 + \cos\alpha (-\cos\alpha) = 1 - \cos^2\alpha = \sin^2\alpha. \text{ Which is independent of } \theta.$$

### TEXTUAL EXERCISE-6 (OBJECTIVE)

$$1. \text{ (c) } \frac{x}{a} = \cos^3\theta \Rightarrow \cos\theta = \left( \frac{x}{a} \right)^{1/3}$$

$$\text{Similarly } \sin\theta = (y/b)^{1/3}$$

$$\text{Now } \sin^2\theta + \cos^2\theta = 1 \Rightarrow \left( \frac{x}{a} \right)^{2/3} + \left( \frac{y}{b} \right)^{2/3} = 1$$

$$2. \text{ (b) } \left( \frac{x}{a} \right)^{1/3} = \sec\theta \text{ and } \left( \frac{y}{b} \right)^{1/3} = \tan\theta$$

$$\text{Now } \sec^2\theta - \tan^2\theta = 1 \Rightarrow \left( \frac{x}{a} \right)^{2/3} - \left( \frac{y}{b} \right)^{2/3} = 1$$

$$3. \text{ (b) } \sin\theta + \cos\theta = m$$

$$\Rightarrow \sin^2\theta + \cos^2\theta + 2\sin\theta \cos\theta = m^2$$

$$\Rightarrow \sin\theta \cos\theta = \frac{m^2 - 1}{2}$$

Also  $\sec\theta + \text{cosec}\theta = n$

$$\Rightarrow \frac{1}{\cos\theta} + \frac{1}{\sin\theta} = n \Rightarrow \frac{\sin\theta + \cos\theta}{\sin\theta \cos\theta} = n$$

$$\Rightarrow m = n \left[ \frac{m^2 - 1}{2} \right] \Rightarrow 2m = n(m^2 - 1)$$

$$4. \text{ (a) } \sec\theta - \cos\theta = n$$

$$\Rightarrow \frac{1 - \cos^2\theta}{\cos\theta} = n \Rightarrow \frac{\sin^2\theta}{\cos\theta} = n$$

$$\Rightarrow \frac{\tan^2 \theta}{\sec \theta} = n \quad \dots (i)$$

$$\text{Also } \cot \theta + \tan \theta = m \Rightarrow \frac{1 + \tan^2 \theta}{\tan \theta} = m$$

$$\Rightarrow \frac{\sec^2 \theta}{\tan \theta} = m \quad \dots (ii)$$

From (i) and (ii) we get,  $m^2 n = \sec^3 \theta$  and  $mn^2 = \tan^3 \theta$   
 $\sec \theta = (m^2 n)^{1/3}$  and  $\tan \theta = (mn^2)^{1/3}$

$$\text{Also } \sec^2 \theta - \tan^2 \theta = 1 \Rightarrow m^{4/3} \cdot n^{2/3} - m^{2/3} \cdot n^{4/3} = 1$$

$$\Rightarrow m [mn^2]^{1/3} - n [m^2 n]^{1/3} = 1$$

$$5. (c) \quad a \cos \theta + b \sin \theta = m \quad \dots (i)$$

$$a \sin \theta - b \cos \theta = n \quad \dots (ii)$$

Squaring and adding we get,  $a^2 + b^2 = m^2 + n^2$

$$6. (d) \quad \tan \theta + \sin \theta = m \quad \dots (i)$$

$$\tan \theta - \sin \theta = n \quad \dots (ii)$$

Adding (i) and (ii) we get,  $2 \tan \theta = m + n$

$$\Rightarrow \tan \theta = \frac{m+n}{2} \quad \dots (iii)$$

$$\text{Equation (i) - equation (ii) gives, } \sin \theta = \frac{m-n}{2} \quad \dots (iv)$$

$$\text{From (iii) and (iv) we have } \cos \theta = \frac{m-n}{m+n} \quad \dots (v)$$

Now multiplying (i) and (ii), we get  $\tan^2 \theta - \sin^2 \theta = m \cdot n$   
 $\Rightarrow \sin^2 \theta [1/\cos^2 \theta - 1] = m \cdot n$

$$\Rightarrow \sin^2 \theta = \frac{(1 - \cos^2 \theta)}{\cos^2 \theta} = m \cdot n$$

$$\Rightarrow \frac{\sin^4 \theta}{\cos^4 \theta} = m \cdot n \quad \Rightarrow \frac{(m-n)^4 \cdot (m+n)^2}{16 \cdot (m+n)^2} = m \cdot n$$

$$\Rightarrow (m^2 - n^2) = 16mn \quad \Rightarrow m^2 - n^2 = 4\sqrt{mn}$$

$$7. (b) \quad x = \sec \phi - \tan \phi \quad \dots (i)$$

$$x = \frac{1}{\cos \theta} - \frac{\sin \theta}{\cos \theta} = \frac{1 - \sin \theta}{\cos \theta}$$

$$\text{Also } y = \operatorname{cosec} \theta + \cot \theta = \frac{1}{\sin \theta} + \frac{\cos \theta}{\sin \theta} = \frac{1 + \cos \theta}{\sin \theta}$$

$$xy = \frac{(1 - \sin \theta)(1 + \cos \theta)}{\sin \theta \cos \theta}$$

$$= \frac{1 + \cos \theta - \sin \theta - \sin \theta \cos \theta}{\sin \theta \cos \theta}$$

$$\Rightarrow xy + 1 = \frac{1 + \cos \theta - \sin \theta}{\sin \theta \cos \theta}$$

$$= \frac{\sin^2 \theta + \cos^2 \theta + \cos \theta - \sin \theta}{\sin \theta \cos \theta}$$

$$= (\tan \theta + \cot \theta) + \left( \frac{1}{\sin \theta} - \frac{1}{\cos \theta} \right)$$

$$= (\tan \theta + \cot \theta) - [\sec \theta - \operatorname{cosec} \theta] = y - x$$

$$\Rightarrow xy + x = y - 1 \quad \Rightarrow x = \frac{y-1}{y+1}$$

$$8. (d) \quad p = \frac{2 \sin \theta}{1 + \cos \theta + \sin \theta}, \quad q = \frac{\cos \theta}{1 + \sin \theta}$$

$$p = \frac{2 \cdot 2 \sin \left( \frac{\theta}{2} \right) \cdot \cos \left( \frac{\theta}{2} \right)}{2 \cos^2 \left( \frac{\theta}{2} \right) + 2 \sin \left( \frac{\theta}{2} \right) \cos \left( \frac{\theta}{2} \right)}$$

$$q = \frac{\cos^2 \left( \frac{\theta}{2} \right) - \sin^2 \left( \frac{\theta}{2} \right)}{\sin^2 \left( \frac{\theta}{2} \right) + \cos^2 \left( \frac{\theta}{2} \right) + 2 \sin \left( \frac{\theta}{2} \right) \cos \left( \frac{\theta}{2} \right)}$$

$$p = \frac{2 \sin \left( \frac{\theta}{2} \right)}{\cos \left( \frac{\theta}{2} \right) + \sin \left( \frac{\theta}{2} \right)}, \quad q = \frac{\cos^2 \left( \frac{\theta}{2} \right) - \sin^2 \left( \frac{\theta}{2} \right)}{\left( \cos \left( \frac{\theta}{2} \right) + \sin \left( \frac{\theta}{2} \right) \right)^2}$$

$$\Rightarrow p + q = \frac{\cos \left( \frac{\theta}{2} \right) + \sin \left( \frac{\theta}{2} \right)}{\cos \left( \frac{\theta}{2} \right) + \sin \left( \frac{\theta}{2} \right)} = 1$$

$$9. (d) \quad \tan \theta - \cot \theta \quad \dots (i)$$

$$\sin \theta + \cot \theta = b \quad \dots (ii)$$

Squaring both sides of (ii) we get,  $1 + 2 \sin \theta \cos \theta = b^2$

$$\sin \theta \cos \theta = \frac{b^2 - 1}{2} \quad \dots (iii)$$

$$\Rightarrow \sin(2\theta) = b^2 - 1 \quad \dots (iv)$$

$$\text{Also from (i) } \frac{\sin \theta}{\cos \theta} - \frac{\cos \theta}{\sin \theta} = a$$

$$\Rightarrow -\cos(2\theta) = a \sin \theta \cos \theta$$

$$\Rightarrow \cos(2\theta) = -a \cdot \left( \frac{b^2 - 1}{2} \right) = \frac{a(1 - b^2)}{2}$$

$$= \cos(2\theta) = \frac{a(1 - b^2)}{2} \quad \dots (v)$$

$$\text{From (iv) and (v), we get, } \frac{a^2(1 - b^2)^2}{4} + (b^2 - 1)^2 = 1$$

$$\Rightarrow 4(b^2 - 1)^2 + a^2(1 - b^2)^2 = 4$$

$$\Rightarrow (b^2 - 1)^2(a^2 + 4) = 4$$

### TEXTUAL EXERCISE-7 (OBJECTIVE)

$$1. (c) \quad -1 \leq \cos \theta \leq 1 \Rightarrow -5 \leq 5 \cos \theta \leq 5$$

$$\Rightarrow -5 + 12 \leq 5 \cos \theta + 12 \leq 5 + 12$$

$$\Rightarrow \text{Minimum value} = 7$$

$$2. (d) \quad \text{Let } y = 3 \cos x + 4 \sin x + 5$$

$$\text{Since } -5 \leq \cos x + 4 \sin x \leq 5$$

$$\Rightarrow y \in [0, 10]$$

$$3. (d) \quad y = 4 \sin^2 x + 3 \cos^2 x = \frac{4[1 - \cos(2x)]}{2} + 3 \left[ \frac{1 + \cos(2x)}{2} \right]$$

$$= \frac{7}{2} - 2 \cos(2x) + \frac{3}{2} \cos(2x) = \frac{7}{2} - \frac{\cos(2x)}{2}$$

Since  $-1 \leq \cos(2x) \leq 1$

$$\Rightarrow 1 \geq -\cos(2x) \geq -1 \Rightarrow -1 \leq -\cos(2x) \leq 1$$

$$\Rightarrow -\frac{1}{2} \leq -\frac{1}{2}\cos(2x) \leq \frac{1}{2}$$

$$\Rightarrow \frac{7}{2} - \frac{1}{2} \leq \frac{7}{2} - \frac{1}{2}\cos(2x) \leq \frac{7}{2} + \frac{1}{2}$$

$$\Rightarrow 3 \leq y \leq 4 \quad \Rightarrow \text{Maximum values is 4}$$

*Aliter:*  $y = 4\sin^2 x + 3[1 - \sin^2 x] = 3 + \sin^2 x$

Since  $0 \leq \sin^2 x \leq 1 \Rightarrow 3 \leq y \leq 4$

4. (c)  $y = \cos^2 x + \frac{1}{\cos^2 x}$

Using AM  $\geq$  GM. we get  $\frac{\cos^2 x + \frac{1}{\cos^2 x}}{2} \geq \sqrt{\cos^2 x \cdot \frac{1}{\cos^2 x}}$

$$\Rightarrow \cos^2 x + \sec^2 x \geq 2 \Rightarrow y \geq 2$$

5. (c)  $y = 5\cos\theta + 3\cos\left(\theta + \frac{\pi}{5}\right) + 3$

$$= 5\cos\theta + 3\left[\cos\theta \cos\frac{\pi}{5} - \sin\theta \sin\frac{\pi}{5}\right] + 3$$

$$= 5\cos\theta + \frac{3}{2}\cos\theta - \frac{3\sqrt{3}}{2}\sin\theta + 3$$

$$= \frac{13}{2}\cos\theta - \frac{3\sqrt{3}}{2}\sin\theta + 3$$

Now  $-\sqrt{\frac{169}{4} + \frac{27}{4}} \leq \frac{13}{2}\cos\theta - \frac{3\sqrt{3}}{2}\sin\theta \leq \sqrt{\frac{169}{4} + \frac{27}{4}}$

$$\Rightarrow -7 + 3 \leq y \leq 7 + 3 \Rightarrow -4 \leq y \leq 10$$

6. (a)  $y = \sin\left(x + \frac{\pi}{6}\right) + \cos\left(x + \frac{\pi}{6}\right)$

$$= \sin x \cos\frac{\pi}{6} + \cos x \sin\frac{\pi}{6} + \cos x \cos\frac{\pi}{6} - \sin x \sin\frac{\pi}{6}$$

$$= \left(\frac{\sqrt{3}}{2} - \frac{1}{2}\right)\sin x + \left(\frac{1}{2} + \frac{\sqrt{3}}{2}\right)\cos x$$

Let  $\frac{\sqrt{3}-1}{2} = r \sin\theta, \frac{\sqrt{3}+1}{2} = r \cos\theta$

So that  $\tan\theta = \frac{\pi}{12}$

Now  $y = r \cos(x - \theta)$ , which allows its maximum value when  $x - \theta = 0^\circ$

$$\Rightarrow x = \theta$$

$$\Rightarrow x = \pi/12$$

7. (a) Using A.M.  $\geq$  G.M.

$$\frac{\tan^2 \alpha + \cot^2 \alpha}{2} \geq \sqrt{\tan^2 \alpha \cdot \cot^2 \alpha}$$

$$\Rightarrow \tan^2 \alpha + \cot^2 \alpha \geq 2$$

z We have  $y = \cos^2\left(\frac{\pi}{3} - x\right) \cos^2\left(\frac{\pi}{3} + x\right) = \sin\left(\frac{2\pi}{3}\right) \sin(2x)$

$$= \frac{\sqrt{3}}{2} \sin(2x)$$

$$\therefore y_{\max} = \frac{\sqrt{3}}{2}$$

9. (a)  $-\sqrt{9+16} \leq 3\sin\theta - 4\cos\theta \leq \sqrt{9+16}$

$$\Rightarrow 7 - 5 \leq 3\sin\theta - 4\cos\theta + 7 \leq 5 + 7$$

$$\Rightarrow 2 \leq 3\sin\theta - 4\cos\theta + 7 \leq 12$$

$$\therefore \text{Minimum value } 1/12$$

10. (c) Maximum value 1/2

11. (b)  $y = \cos x + \cos(\sqrt{2}x)$

Clearly  $y$  is maximum at  $x = 0$  and  $y_{\max}$  is 2. Also period of  $\cos x$  is  $2\pi$  and that of  $\cos(\sqrt{2}x)$  is  $\frac{2\pi}{\sqrt{2}}$ . i.e.,  $\sqrt{2}\pi$

$\therefore \cos x + \cos(\sqrt{2}x)$  is not periodic

$\Rightarrow y_{\max}$  will not be obtained again.

12. (b)  $f(x) = \cos x + \cos(\sqrt{2}x)$

In the similar way as done in above question minimum value will also occur only once.

13. (d)  $y = \sin^2 x - 12x + 7 = 4[\sin^2 x - 3\sin x + 7/4]$

$$= 4\left[\left(\sin x - \frac{3}{2}\right)^2 - \frac{9}{4} + \frac{7}{4}\right] = 4\left(\sin x - \frac{3}{2}\right)^2 - 2$$

Now  $-1 \leq \sin x \leq 1 \Rightarrow -1 - \frac{3}{2} \leq \sin x - \frac{3}{2} \leq 1 - \frac{3}{2}$

$$\Rightarrow \frac{-5}{2} \leq \sin x - \frac{3}{2} \leq \frac{-1}{2}$$

$$\Rightarrow \frac{1}{4} \leq \left(\sin x - \frac{3}{2}\right)^2 \leq \frac{25}{4}$$

$$\Rightarrow \frac{1}{4} \times 4 \leq 4\left(\sin x - \frac{3}{2}\right)^2 \leq \frac{25}{4} \times 4$$

$$\Rightarrow 1 \leq 4\left(\sin x - \frac{3}{2}\right)^2 \leq 25$$

$$\Rightarrow 1 - 2 \leq 4\left(\sin x - \frac{3}{2}\right)^2 - 2 \leq 25 - 2$$

$$\therefore y \in [-1, 23]$$

*Aliter:* Put  $\sin x = t$

$$\therefore y = 4t^2 - 12t + 7 \quad [-1 \leq t \leq 1]$$

$\therefore y$  is a quadratic in 't' whose graph is a parabola with

vertex at  $\left(\frac{3}{2}, -2\right)$

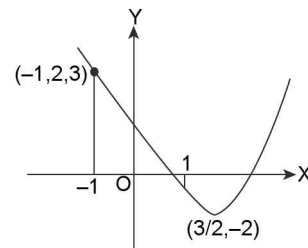

$\therefore$  Maximum value occurs at  $t = -1$  and  $y_{\max} = 23^\circ$

**TEXTUAL EXERCISE-16 (SUBJECTIVE)**

1. (a) We know that  $\sin 18^\circ = \frac{\sqrt{5}-1}{4}$

$\Rightarrow \sin 18^\circ$  is a root of equation  

$$x^2 - \left[ \left( \frac{\sqrt{5}-1}{4} \right) + \left( \frac{-\sqrt{5}-1}{4} \right) \right] x - \frac{1}{4} = 0$$

i.e.,  $x^2 + \frac{1}{2}x - \frac{1}{4} = 0$  or  $4x^2 + 2x - 1 = 0$

Next let  $\theta = 18^\circ \Rightarrow 5\theta = 90^\circ$   
 $\Rightarrow 3\theta + 2\theta = 90^\circ \Rightarrow 3\theta = 90^\circ - 2\theta$   
 $\Rightarrow \sin(3\theta) = \sin(90^\circ - 2\theta) = \cos 2\theta$   
 $\Rightarrow \sin(3\theta) = 1 - 2\sin^2\theta$   
 $\Rightarrow 3\sin\theta - 4\sin^3\theta = 1 - 2\sin^2\theta$   
 $\Rightarrow 4\sin^3\theta - 2\sin^2\theta - 3\sin\theta + 1 = 0$

Hence  $\sin 18^\circ$  is a root of equation  $4x^3 - 2x^2 - 3x + 1 = 0$

Since  $\sin 18^\circ$  is root of both  $4x^2 + 2x - 1 = 0$  and  $4x^3 - 2x^2 - 3x + 1 = 0$

$\Rightarrow 4x^2 + 2x - 1$  is a factor of  $4x^3 - 2x^2 - 3x + 1 = 0$

(b) Let  $\alpha = 18^\circ \Rightarrow 5\alpha = 90^\circ$   
 $\Rightarrow \cos(5\alpha) = 0$   
 $\Rightarrow 5\cos^5\alpha - 5\cos^3\alpha \sin^2\alpha + 5\cos\alpha \sin^4\alpha = 0$   
 $\Rightarrow \cos^5\alpha - 10\cos^3\alpha(1 - \sin^2\alpha) + 5\cos\alpha(1 - \cos^2\alpha)^2 = 0$   
 $\Rightarrow 16\cos^5\alpha - 20\cos^3\alpha + 5\cos\alpha = 0$   
 $\Rightarrow \cos\alpha [16\cos^4\alpha - 20\cos^2\alpha + 5] = 0$   
 $\cos\alpha \neq 0 \Rightarrow 16\cos^4\alpha - 20\cos^2\alpha + 5 = 0$   
 $\Rightarrow \cos 18^\circ$  is a root of equation  $16x^4 - 20x^2 + 5 = 0$  .....(i)

2. Let  $\theta = \frac{(2n+1)\pi}{7}$   $n = 0, 1, 2, 3, \dots, 6$

$\Rightarrow 7\theta = (2n+1)\pi \Rightarrow 4\theta = (2n+1)\pi - 3\theta$   
 $\Rightarrow \cos(4\theta) = -\cos(3\theta)$   
 $\Rightarrow 2\cos^2(2\theta) - 1 = 3\cos\theta - 4\cos^3\theta$   
 $\Rightarrow 2[2\cos^2\theta - 1] - 1 = 3\cos\theta - 4\cos^3\theta$   
 $\Rightarrow 2[2x^2 - 1] - 1 = 3x - 4x^3$

Where  $x = \cos\theta$

$\Rightarrow 8x^4 + 4x^3 - 8x^2 - 3x + 1 = 0$  .....(i)

$\Rightarrow (x+1)(8x^3 - 4x^2 - 4x + 1) = 0$   
 $\Rightarrow 8x^3 - 4x^2 - 4x + 1 = 0$  .....(ii)

Hence roots of (1) are

$\cos\left(\frac{\pi}{7}\right), \cos\left(\frac{3\pi}{7}\right), \cos\left(\frac{5\pi}{7}\right), \cos\left(\frac{7\pi}{7}\right),$

$\cos\left(\frac{9\pi}{7}\right), \cos\left(\frac{11\pi}{7}\right), \cos\left(\frac{13\pi}{7}\right)$

But  $\cos\left(\frac{9\pi}{7}\right) = \cos\left(2\pi - \frac{5\pi}{7}\right) = \cos\left(\frac{5\pi}{7}\right);$

$\cos\left(\frac{11\pi}{7}\right) = \cos\left(2\pi - \frac{3\pi}{7}\right) = \cos\left(\frac{3\pi}{7}\right)$

and  $\cos\left(\frac{13\pi}{7}\right) = \cos\left(\frac{\pi}{7}\right)$

$\therefore \cos\left(\frac{\pi}{7}\right), \cos\left(\frac{3\pi}{7}\right) \& \cos\left(\frac{5\pi}{7}\right)$

are roots of  $8x^3 - 4x^2 - 4x + 1 = 0$  ... (iii)

Now put  $x = 1/x$  in equation (iii) we get,

$\frac{8}{x^3} - \frac{4}{x^2} - \frac{4}{x} + 1 = 0$

$x^3 - 4x^2 - 4x + 8 = 0$  and its roots are  $\sec(\pi/7),$

$\sec\left(\frac{3\pi}{7}\right), \sec\left(\frac{5\pi}{7}\right)$

$\therefore \sec\left(\frac{\pi}{7}\right) + \sec\left(\frac{3\pi}{7}\right) + \sec\left(\frac{5\pi}{7}\right) = 4$

[ $\because$  sum of roots of  $ax^3 + bx^2 + cx + d = 0$  is  $-b/a$ ]

Also put  $y = 1/x^2$  in equation (iii) we get

$\frac{8}{y^{3/2}} - \frac{4}{y} - \frac{4}{\sqrt{y}} + 1 = 0$

$\Rightarrow 8 - 4\sqrt{y} - 4y + y^{3/2} = 0$

$\Rightarrow \sqrt{y}(y-4) = 4(y-2)$

$\Rightarrow y(y-4)^2 = 16(y-2)^2$

$\Rightarrow y^3 - 24y^2 + 80y - 64 = 0$

and its roots are  $\sec^2(\pi/7), \sec^2\left(\frac{3\pi}{7}\right), \sec^2\left(\frac{5\pi}{7}\right).$

Now replace  $y$  by  $(y+1)$  we get  $(y+1)^3 - 24(y+1)^2 + 80(y+1) - 64 = 0$

$\Rightarrow y^3 - 21y^2 + 35y - 7 = 0$

Hence its roots are  $\tan^2\left(\frac{\pi}{7}\right), \tan^2\left(\frac{3\pi}{7}\right), \tan^2\left(\frac{5\pi}{7}\right).$

3. Since  $\tan^2\left(\frac{\pi}{7}\right), \tan^2\left(\frac{3\pi}{7}\right), \tan^2\left(\frac{5\pi}{7}\right)$  are roots of equation

$y^3 - 21y^2 + 35y - 7 = 0$

$\Rightarrow \tan^2\left(\frac{\pi}{7}\right) \tan^2\left(\frac{3\pi}{7}\right) \tan^2\left(\frac{5\pi}{7}\right) = 7$

$\Rightarrow \tan\left(\frac{\pi}{7}\right) \cdot \tan\left(\frac{3\pi}{7}\right) \cdot \tan\left(\frac{5\pi}{7}\right) = \sqrt{7}$

**TEXTUAL EXERCISE-17 (SUBJECTIVE)**

1. (a)  $\sec^2\theta \geq 1$

$\Rightarrow \sec^2\left(\frac{A}{4} + \frac{\pi}{6}\right) + \sec^2\left(\frac{\pi}{4} + \frac{B}{4}\right) + \sec^2\left(\frac{\pi}{3} + \frac{C}{4}\right) \geq 3$

Equality holds if  $\frac{A}{4} + \frac{\pi}{4} = \frac{B}{4} + \frac{\pi}{4} + \frac{\pi}{3} + \frac{c}{4} = 0.$

Not possible

(b) A cosecA + B cosecB + CcosecC consider the graph of  $y = \sin x$

Let P and Q be 2 points on it  $P(A, \sin A), Q\left(\frac{\pi}{2}, 1\right)$

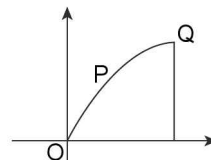

Clearly  $\text{slop of OP} > \text{slop of OQ}$

$$\Rightarrow \frac{\sin A}{A} > \frac{1}{\pi} \Rightarrow \frac{\sin A}{A} > \frac{2}{\pi} \Rightarrow \frac{A}{\sin A} < \frac{\pi}{2} \Rightarrow A \operatorname{cosec} A < \frac{\pi}{2}$$

Similarly  $B \operatorname{cosec} B < \pi/2$ ,  $C \operatorname{cosec} C < \pi/2$

$$\Rightarrow A \operatorname{cosec} A + B \operatorname{cosec} B + C \operatorname{cosec} C < 3\pi/2$$

2. Consider the graph of  $y = \sin x$

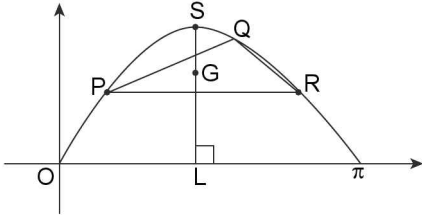

Let  $P(A, \sin A)$ ,  $Q(B, \sin B)$ ,  $R(C, \sin C)$  be any 3 points on it

$$\text{Centroid of } \Delta = G \left( \frac{A+B+C}{3}, \frac{\sin A + \sin B + \sin C}{3} \right)$$

$$\text{and } \left( \frac{A+B+C}{3}, \sin \left( \frac{A+B+C}{3} \right) \right) \text{ and } \left( \frac{A+B+C}{3}, \frac{\sqrt{3}}{2} \right)$$

Clearly  $LS > GL$

$$\Rightarrow \frac{\sqrt{3}}{2} > \frac{\sin A + \sin B + \sin C}{3} \quad \sin A + \sin B + \sin C < \frac{3\sqrt{3}}{2}$$

### TEXTUAL EXERCISE-18 (SUBJECTIVE)

1. (a) Using  $\cos \alpha + \cos(\alpha + \beta) + \cos(\alpha + 2\beta) + \dots + \cos(\alpha$

$$+ (n-1)\beta) = \frac{\cos \left[ \alpha + (n-1) \frac{\beta}{2} \right] \cdot \sin \left( \frac{n\beta}{2} \right)}{\sin \left( \frac{\beta}{2} \right)}$$

Here  $\alpha = \theta$ ,  $\beta = 2\theta$

$$\begin{aligned} \Rightarrow \text{Required sum} &= \frac{\cos[\theta + (n-1)\theta] \sin(n\theta)}{\sin \theta} \\ &= \frac{\cos(n\theta) \sin(n\theta)}{\sin \theta} = \frac{2 \sin(n\theta) \cos(n\theta)}{2 \sin \theta} \\ &= \frac{1}{2} \sin(2n\theta) \operatorname{cosec} \theta \end{aligned}$$

$$(b) \cos \left( \frac{A}{2} \right) + \cos(2A) + \cos \left( \frac{7A}{2} \right) + \dots$$

Here  $\alpha = A/2$ ,  $\beta = 3A/2$

$$\begin{aligned} \therefore \text{Required sum} &= \frac{\cos \left( \frac{A}{2} + (n-1) \cdot \frac{3A}{4} \right) \cdot \sin \left( \frac{n \cdot 3A}{4} \right)}{\sin \left( \frac{3A}{4} \right)} \\ &= \cos \left( \frac{3n-1}{4} A \right) \cdot \sin \left( \frac{3n}{4} A \right) \cdot \operatorname{cosec} \left( \frac{3}{4} A \right) \end{aligned}$$

2.  $\sin a + \sin 2a + \sin 3a + \dots + \sin(na)$

$$= \frac{\sin \left[ a + (n-1) \cdot \frac{a}{2} \right] \cdot \sin(na)}{\sin \left( \frac{a}{2} \right)} = \sin \left( \left( \frac{(n+1)}{2} \right) a \right) \cdot \frac{\sin(na)}{\sin \left( \frac{a}{2} \right)}$$

[ $\because \alpha = a$ ,  $\beta = a$ ]

$$\text{Also } \cos a + \cos(2a) + \dots + \cos(na) = \frac{\cos \left( \frac{n+1}{2} \right) \cdot a \cdot \sin(na)}{\sin \left( \frac{a}{2} \right)}$$

$$\therefore \text{Required expression} = \tan \left( \frac{n+1}{2} a \right)$$

3.  $\cos \theta + \cos(3\theta) + \cos(5\theta) + \dots$  n terms =  $1/2 \sin(2n\theta) \operatorname{cosec} \theta$

$$\begin{aligned} \Rightarrow \text{required expression} &= \frac{1}{2} \sin \left( \frac{2n\pi}{2n+1} \right) \operatorname{cosec} \left( \frac{\pi}{2n+1} \right) \\ &= \frac{1}{2} \sin \left( \frac{(2n+1)\pi - \pi}{2n+1} \right) \operatorname{cosec} \left( \frac{\pi}{2n+1} \right) \\ &= \frac{1}{2} \cdot \sin \left( \pi - \frac{\pi}{2n+1} \right) \cdot \operatorname{cosec} \left( \frac{\pi}{2n+1} \right) = \frac{1}{2} \end{aligned}$$

4. Let  $C = \cos \alpha - \cos(\alpha + \beta) + \cos(\alpha + 2\beta) - \cos(\alpha + 3\beta) + \dots - \cos(\alpha + (2n-1)\beta)$  and

$$S = \sin \alpha - \sin(\alpha + \beta) + \sin(\alpha + 2\beta) - \sin(\alpha + 3\beta) + \dots - \sin(\alpha + (2n-1)\beta)$$

$$\therefore C + iS = e^{i\alpha} - e^{i(\alpha+\beta)} + e^{i(\alpha+2\beta)} - e^{i(\alpha+3\beta)} + \dots - e^{-i(\alpha+(2n-1)\beta)}$$

$$= e^{i\alpha} (1 - e^{i\beta} + e^{2i\beta} - e^{3i\beta} + \dots - e^{-(2n-1)i\beta})$$

$$= e^{i\alpha} \left[ \frac{1 - (-e^{i\beta})^{2n}}{1 - (-e^{i\beta})} \right] = e^{i\alpha} \left[ \frac{1 - e^{2in\beta}}{1 + e^{i\beta}} \right]$$

$$= \frac{e^{i\alpha} - e^{i(\alpha+2\beta n)}}{(1 + \cos \beta + i \sin \beta)} = \frac{e^{i\alpha} - e^{i(\alpha+2\beta n)}}{2 \cos^2 \frac{\beta}{2} + 2i \sin \frac{\beta}{2} \cos \frac{\beta}{2}}$$

$$= \frac{e^{i\alpha} - e^{i(\alpha+2\beta n)}}{2 \cos \frac{\beta}{2} \left( \cos \frac{\beta}{2} + i \sin \frac{\beta}{2} \right)} = \frac{e^{i\alpha} - e^{i(\alpha+2\beta n)} \left( \cos \frac{\beta}{2} - i \sin \frac{\beta}{2} \right)}{2 \cos \frac{\beta}{2}}$$

$$= \frac{(\cos \alpha + i \sin \alpha) [1 - (\cos(2\beta n) + i \sin 2\beta n)] \left( \cos \frac{\beta}{2} - i \sin \frac{\beta}{2} \right)}{\left( 2 \cos \frac{\beta}{2} \right)}$$

$$= \frac{(\cos \alpha + i \sin \alpha) [2 \sin^2 \beta n - i(2 \sin \beta n \cos \beta n)] \left( \cos \frac{\beta}{2} - i \sin \frac{\beta}{2} \right)}{\left( 2 \cos \frac{\beta}{2} \right)}$$

$$= \sin \beta n \sec \beta / 2 (\cos \alpha + i \sin \alpha) (\sin \beta n - i \cos \beta n)$$

$$\left( \cos \frac{\beta}{2} - i \sin \frac{\beta}{2} \right)$$



1.120 > Trigonometry

$$\Rightarrow C = \sin \beta n \cdot \sec \frac{\beta}{2} \left[ \frac{\cos \alpha \sin \beta n \cos \frac{\beta}{2} + \sin \alpha \beta n \cos \frac{\beta}{2}}{\sin \alpha \sin \beta n \sin \frac{\beta}{2} - \cos \alpha \cos \beta n \sin \frac{\beta}{2}} \right]$$

$$\Rightarrow C = \sin \beta n \cdot \sec \frac{\beta}{2} \left[ \frac{\sin \beta n \left( \cos \left( \alpha - \frac{\beta}{2} \right) \right) + \cos(\beta n) \sin \left( \alpha - \frac{\beta}{2} \right)}{\cos(\beta n) \sin \left( \alpha - \frac{\beta}{2} \right)} \right]$$

$$\Rightarrow C = \sin \beta n \sec \frac{\beta}{2} \left[ \sin \left( \alpha + \left( n - \frac{1}{2} \right) \beta \right) \right] \text{Ans}$$

5. Let  $S = \cos \alpha \sin 2\alpha + \sin 2\alpha \cos 3\alpha + \cos 3\alpha \sin 4\alpha + \sin 4\alpha \cos 5\alpha + \dots$  to  $2n$  terms

$$\Rightarrow 2S = \sin 3\alpha + \sin \alpha + \sin 5\alpha - \sin \alpha + \sin 7\alpha + \sin \alpha + \dots + \sin(4n+1)\alpha - \sin \alpha$$

$$\Rightarrow S = \frac{1}{2} (\sin 3\alpha + \sin 5\alpha + \sin 7\alpha + \dots + \sin(4n+1)\alpha)$$

and let  $C = \frac{1}{2} (\cos 3\alpha + \cos 5\alpha + \cos 7\alpha + \dots + \cos(4n+1)\alpha)$

Let  $(C + iS) = \frac{1}{2} [e^{i3\alpha} + e^{i5\alpha} + e^{i7\alpha} + \dots + e^{i(4n+1)\alpha}]$

$$= \frac{1}{2} e^{i3\alpha} \left[ \frac{1 - (e^{i2\alpha})^{2n}}{1 - (e^{i2\alpha})} \right] = \frac{e^{i3\alpha}}{2} \left[ \frac{1 - e^{4n\alpha i}}{1 - e^{2\alpha i}} \right]$$

$$= \frac{e^{i3\alpha}}{2} \left[ \frac{1 - \cos 4n\alpha - i \sin 4n\alpha}{1 - \cos 2\alpha - i \sin 2\alpha} \right]$$

$$= \frac{e^{i3\alpha}}{2} \left[ \frac{2 \sin^2 2n\alpha - i 2 \sin 2n\alpha \cdot \cos 2n\alpha}{2 \sin^2 \alpha - i \sin \alpha \cos \alpha} \right]$$

$$= \frac{e^{i3\alpha}}{2} \left[ \frac{2 \sin 2n\alpha (\sin 2n\alpha - i \cos 2n\alpha)}{2 \sin \alpha (\sin \alpha - i \cos \alpha)} \right]$$

$$= \frac{e^{i3\alpha}}{2} \sin 2n\alpha \operatorname{cosec} \alpha (\sin 2n\alpha - i \cos 2n\alpha) (\sin \alpha + i \cos \alpha)$$

$$\Rightarrow C + iS = \frac{1}{2} \operatorname{cosec} \alpha \cdot \sin 2n\alpha (\cos 3\alpha + i \sin 3\alpha) (\sin 2n\alpha - i \cos 2n\alpha) (\sin \alpha + i \cos \alpha)$$

$$= \frac{1}{2} \operatorname{cosec} \alpha \sin 2n\alpha \cdot e^{i3\alpha} \cdot (-i) e^{i(2n\alpha)} \cdot i \cdot e^{-\alpha}$$

$$= \frac{1}{2} \operatorname{cosec} \alpha \sin 2n\alpha e^{2(n+1)i\alpha}$$

$$\Rightarrow S = \frac{1}{2} \operatorname{cosec} \alpha \sin 2n\alpha \cdot \sin 2(n+1)\alpha \text{ Ans}$$

6.  $\sin^2 \alpha + \sin^2 2\alpha + \sin^2 3\alpha + \dots$  to  $n$  terms

$$= \left( \frac{1 - \cos 2\alpha}{2} \right) + \left( \frac{1 - \cos 4\alpha}{2} \right) + \left( \frac{1 - \cos 6\alpha}{2} \right) + \dots + \left( \frac{1 - \cos 2n\alpha}{2} \right)$$

$$= \frac{n}{2} - \frac{1}{2} (\cos 2\alpha + \cos 4\alpha + \cos 6\alpha + \dots + \cos(2n)\alpha)$$

$$= \frac{n}{2} - \frac{1}{2} C (\text{say}) :$$

Where  $C = \cos 2\alpha + \cos 4\alpha + \cos 6\alpha + \dots + \cos 2n\alpha$

and Let  $S = \sin 2\alpha + \sin 4\alpha + \sin 6\alpha + \dots + \sin 2n\alpha$

$$\therefore C + iS = e^{i2\alpha} + e^{i4\alpha} + e^{i6\alpha} + \dots + e^{i2n\alpha}$$

$$= e^{2\alpha i} \left[ \frac{1 - (e^{i2\alpha})^n}{1 - e^{i2\alpha}} \right] = e^{2\alpha i} \left[ \frac{1 - e^{2n\alpha i}}{1 - e^{i2\alpha}} \right]$$

$$= e^{2\alpha i} \left[ \frac{2 \sin^2 n\alpha - i 2 \sin n\alpha \cos n\alpha}{2 \sin^2 \alpha - i 2 \sin \alpha \cos \alpha} \right] = e^{2\alpha i} \operatorname{cosec} \alpha (-i) e^{in\alpha} \cdot i e^{-i\alpha}$$

$$\Rightarrow C + iS = \sin n\alpha \operatorname{cosec} \alpha e^{i(n+1)\alpha}$$

$$\Rightarrow C = \sin n\alpha \operatorname{cosec} \alpha \cos(n+1)\alpha$$

$$\Rightarrow \text{required expression} = \frac{n}{2} - \frac{1}{2} \sin n\alpha \operatorname{cosec} \alpha \cos(n+1)\alpha$$

$$= \frac{\operatorname{cosec} \alpha}{2} [n \sin \alpha - \sin n\alpha \cos(n+1)\alpha]$$

$$= \frac{\operatorname{cosec} \alpha}{4} [2n \sin \alpha - 2 \sin n\alpha \cos(n+1)\alpha]$$

$$= \frac{\operatorname{cosec} \alpha}{4} [2n \sin \alpha - (\sin(2n+1)\alpha + \sin(-\alpha))]$$

$$= \frac{\operatorname{cosec} \alpha}{4} [(2n+1) \sin \alpha - \sin(2n+1)\alpha] \text{ Ans}$$

TEXTUAL EXERCISE-19 (SUBJECTIVE)

1.  $\therefore \lim_{n \rightarrow \infty} \cos \frac{\pi}{2} \cos \frac{\pi}{2^n} \dots \cos \frac{\pi}{2^n} = \frac{\sin x}{x}$

$\Rightarrow$  taking log on both side

$$\sum_{k=1}^{\infty} \log \cos \frac{\pi}{2^k} = \log \sin x - \log x$$

differentiating both side w.r.t x

$$-\sum_{k=1}^{\infty} \frac{1}{2^k} \tan \frac{x}{2^k} = \cot x - \frac{1}{x}$$

differentiating again w.r.t x we get

$$-\sum_{k=1}^{\infty} \frac{1}{2^{2k}} \sec^2 \frac{x}{2^k} = -\operatorname{cosec}^2 x + \frac{1}{x^2}$$

$$\sum_{k=1}^{\infty} \frac{1}{2^{2k}} \sec^2 \frac{x}{2^k} = \operatorname{cosec}^2 x - \frac{1}{x^2}$$

2. To prove

(a)  $\cos \frac{\pi}{9} \cos \frac{2\pi}{9} \cos \frac{4\pi}{9} = \frac{1}{8}$

$$\text{L.H.S} = \frac{1}{2 \sin \frac{\pi}{9}} \left[ \sin \frac{2\pi}{9} \cos \frac{2\pi}{9} \cos \frac{4\pi}{9} \right]$$

$$= \frac{1}{2 \times 2 \sin \frac{\pi}{9}} \left[ \sin \frac{4\pi}{9} \cos \frac{4\pi}{9} \right]$$

$$= \frac{1}{2 \times 2 \times 2 \sin \frac{\pi}{9}} \left[ \sin \frac{8\pi}{9} \right] = \frac{1}{8 \sin \frac{\pi}{9}} \sin \left( \pi - \frac{\pi}{9} \right) = \frac{1}{8} = R.H.S$$

(b) To prove  $\sin \frac{15\pi}{34} \cdot \sin \frac{13\pi}{34} \cdot \sin \frac{9\pi}{34} \cdot \sin \frac{\pi}{34}$

L.H.S

$$= \sin \left( \frac{17\pi}{34} - \frac{2\pi}{34} \right) \sin \left( \frac{17\pi}{34} - \frac{4\pi}{34} \right) \sin \left( \frac{17\pi}{34} - \frac{8\pi}{34} \right) \sin \frac{\pi}{34}$$

$$= \cos \frac{2\pi}{34} \cdot \cos \frac{4\pi}{34} \cdot \cos \frac{8\pi}{34} \cdot \sin \frac{\pi}{34}$$

$$= \frac{1}{2 \cos \frac{\pi}{34}} \left( \sin \frac{2\pi}{34} \cdot \cos \frac{2\pi}{34} \cdot \cos \frac{4\pi}{34} \cdot \cos \frac{8\pi}{34} \right)$$

$$= \frac{1}{(2)^2 \cos \frac{\pi}{34}} \cdot \left( \sin \frac{4\pi}{34} \cdot \cos \frac{4\pi}{34} \right) \cdot \cos \frac{8\pi}{34}$$

$$= \frac{1}{(2)^3 \cos \frac{\pi}{34}} \cos \frac{8\pi}{34} \cdot \sin \frac{8\pi}{34}$$

$$= \frac{1}{(2)^4 \cos \frac{\pi}{34}} \cdot \sin \left( \frac{16\pi}{34} \right) = \frac{1}{16 \cos \frac{\pi}{34}} \sin \left( \frac{17\pi}{34} - \frac{\pi}{34} \right) = \frac{1}{16}$$

= R.H.S

3. L.H.S

$$= \left( \cos \frac{\pi}{15} \cos \frac{2\pi}{15} \cos \frac{4\pi}{15} \right) \cos \frac{7\pi}{15} \cdot \cos \frac{3\pi}{15} \cdot \cos \frac{6\pi}{15} \cdot \cos \frac{5\pi}{15}$$

$$= \frac{\sin(2)^3 \frac{\pi}{15}}{(2)^3 \sin \frac{\pi}{15}} \cdot \cos \left( \frac{7\pi}{15} \right) \sin \left( \frac{12\pi}{15} \right) \frac{1}{(2)^2 \sin \frac{3\pi}{15}}$$

$$= \frac{\sin \frac{8\pi}{15}}{(2)^6 \sin \frac{\pi}{15}} \cos \frac{7\pi}{15} \cdot \frac{\sin \frac{12\pi}{15}}{\sin \frac{3\pi}{15}}$$

$$= \frac{1}{(2)^7} \cdot 2 \sin \left( \pi - \frac{7\pi}{15} \right) \cos \frac{7\pi}{15} \times \left( \frac{\sin \frac{12\pi}{15}}{\sin \frac{3\pi}{15}} \right) \times \frac{1}{\sin \frac{\pi}{15}}$$

$$= \frac{1}{(2)^7} \cdot \frac{\sin \frac{14\pi}{15}}{\sin \frac{\pi}{15}} \cdot \frac{\sin \frac{12\pi}{15}}{\sin \frac{3\pi}{15}}$$

$$= \frac{1}{(2)^7} \frac{\sin \left( \pi - \frac{\pi}{15} \right)}{\sin \left( \frac{\pi}{15} \right)} \cdot \sin \left( \frac{\pi - \frac{3\pi}{15}}{\sin \frac{3\pi}{15}} \right) = \frac{1}{(2)^7} = R.H.S$$

4. L.H.S =  $16 \cos \frac{2\pi}{15} \cos \frac{4\pi}{15} \cos \frac{8\pi}{15} \cos \frac{16\pi}{15}$

$$= 16 \times \frac{\sin(2)^4 \cdot \frac{2\pi}{15}}{(2)^4 \sin \frac{2\pi}{15}} = \frac{\sin \frac{32\pi}{15}}{\sin \frac{2\pi}{15}} = \frac{\sin \left( 2\pi + \frac{2\pi}{15} \right)}{\sin \frac{2\pi}{15}} = 1 = R.H.S$$

5. LHS =  $\left( 1 - \tan^2 \frac{\theta}{2} \right) \left( 1 - \tan^2 \frac{\theta}{2^2} \right) \left( 1 - \tan^2 \frac{\theta}{2^3} \right) \dots \infty$

$$= \lim_{n \rightarrow \infty} \left[ \frac{\cos \theta}{\cos^2 \frac{\theta}{2}} \cdot \frac{\cos \frac{\theta}{2}}{\cos^2 \frac{\theta}{2^2}} \cdot \frac{\cos \frac{\theta}{2^2}}{\cos^2 \frac{\theta}{2^3}} \dots \frac{\cos \left( \frac{\theta}{2^{n-1}} \right)}{\cos^2 \left( \frac{\theta}{2^n} \right)} \right]$$

$$= \lim_{n \rightarrow \infty} \left[ \frac{\cos \theta}{\cos \frac{\theta}{2}} \left( \frac{1}{\cos \frac{\theta}{2^2}} \cdot \frac{1}{\cos \frac{\theta}{2^3}} \dots \frac{1}{\cos^2 \frac{\theta}{2^n}} \right) \right]$$

$$= \lim_{n \rightarrow \infty} \left[ \frac{\cos \theta}{\cos \frac{\theta}{2} \cdot \cos \frac{\theta}{2^2} \cdot \cos \frac{\theta}{2^3} \dots \cos \frac{\theta}{2^n} \cos \frac{\theta}{2^n}} \right]$$

$$= \lim_{n \rightarrow \infty} \left[ \frac{\cos \theta}{\left( \frac{\sin \left( 2^n \cdot \frac{\theta}{2^n} \right)}{(2)^n \sin \left( \frac{\theta}{2^n} \right)} \right) \cdot \cos \left( \frac{\theta}{2^n} \right)} \right]$$

$$= \lim_{n \rightarrow \infty} \left[ \frac{\cos \theta}{\frac{\sin \theta}{\theta} \cdot \cos \frac{\theta}{2^n}} \right] = \theta \frac{\cos \theta}{\sin \theta} = \theta \cot \theta = R.H.S$$

**SECTION-III (ONLY ONE CORRECT ANSWER)**

1. (a) We know that if  $A + B = 45^\circ$  then  $(1 + \tan A)(1 + \tan B) = 2$   
 $\Rightarrow \alpha + 4\alpha = \pi/4 \Rightarrow \alpha = \pi/20$

2. (c)  $\theta = \frac{2\pi}{2009} \Rightarrow 2009\theta = 2\pi$

$$\Rightarrow \theta = 2p - 2008\theta \Rightarrow \cos \theta = \cos(2008\theta)$$

$$\Rightarrow \cos(2\theta) = \cos(2007\theta)$$

$$\Rightarrow \sin \theta = -\sin(2008\theta)$$

Let  $P = \cos \theta \cos 2\theta \cos 3\theta \dots \cos 1004\theta$  and  $Q = \sin \theta \sin(2\theta) \sin(3\theta) \dots \sin(1004\theta)$

$$\Rightarrow 2^{1004} \cdot P \cdot Q = \sin(2\theta) \sin(4\theta) \sin(6\theta) \dots \sin(2008\theta) \dots (i)$$

$$\text{Since } \sin(\theta) = -\sin(2008\theta)$$

$$\sin(3\theta) = -\sin(2005\theta)$$

$$\sin(1003\theta) = -\sin(1005\theta)$$

$$\sin(1004\theta) = -\sin(1004\theta)$$

$\therefore$  From (1),  $2^{1004} P \cdot Q = \sin \theta \sin(2\theta) \sin 3\theta \sin 4\theta \dots$

$$\sin(1004\theta) = Q$$

$$\Rightarrow P = \frac{1}{2^{1004}}$$

1.122 > Trigonometry

3. (b)  $x = a \cos^2\theta \sin\theta \Rightarrow x^2 = a^2 \cos^4\theta \sin^2\theta$   
 $y = a \sin^2\theta \cos\theta \Rightarrow y^2 = a^2 \sin^4\theta \cos^2\theta$   
 $\Rightarrow (x^2 + y^2) = a^2 \sin^2\theta \cos^2\theta [\cos^2\theta + \sin^2\theta]$   
 $\Rightarrow (x^2 + y^2)^3 = a^6 \sin^6\theta \cos^6\theta$   
 Also  $x^2 y^2 = a^2 \cos^4\theta \sin^2\theta \cdot a^2 \sin^4\theta \cos^2\theta = a^4 \sin^6\theta \cos^6\theta$   
 $\Rightarrow (x^2 + y^2)^3 = a^2 x^2 y^2$

4. (a) Period of  $|\sin(4x)| = \pi/4$ ,  $|\cos(4x)| = \pi/4$   
 But  $|\sin 4(\pi/8 + x)| = |\cos(4x)|$   
 $\therefore$  f and g are interchangeable  
 $\therefore \pi/8$ .  
 $\therefore$  Similarly for denominator.  
 $\therefore$  Required period is  $\pi/8$ .

5. (a)  $\angle P + \angle Q = \frac{\pi}{2} \Rightarrow \frac{P}{2} + \frac{Q}{2} = \frac{\pi}{4}$

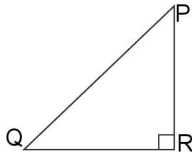

$\therefore \frac{\tan\left(\frac{P}{2}\right) + \tan\left(\frac{Q}{2}\right)}{1 - \tan\left(\frac{P}{2}\right)\tan\left(\frac{Q}{2}\right)} = 1$

$\Rightarrow \frac{-\frac{b}{a}}{1 - \frac{c}{a}} = 1$

$\Rightarrow -\frac{b}{a} = 1 - \frac{c}{a} \Rightarrow c - b = a \Rightarrow a + b = c$

6. (c)  $\tan(2\alpha) = \tan(\alpha + \alpha + \beta - \beta) = \tan[(\alpha + \beta) + (\alpha - \beta)]$   
 $= \frac{\tan(\alpha + \beta) + \tan(\alpha - \beta)}{1 - \tan(\alpha + \beta)\tan(\alpha - \beta)} = \frac{4}{1-1} = \infty$

$\Rightarrow 2\alpha = \pi/2 \Rightarrow \alpha = \pi/4$

Also  $\tan(2\beta) = \tan(\beta + \beta + \alpha - \alpha)$   
 $= \tan[(\alpha + \beta) - (\alpha - \beta)] = \tan(\alpha + \beta) + \tan(\alpha + \beta) = 4$   
 $= \tan(\alpha + \beta) \cdot \tan(\alpha - \beta) = 1$

$= \tan(\alpha + \beta) - \tan(\alpha + \beta) = \frac{\sqrt{D}}{a} = \sqrt{12}$

$= \frac{\tan(\alpha + \beta) - \tan(\alpha - \beta)}{1 + \tan(\alpha + \beta)\tan(\alpha - \beta)} = \frac{\sqrt{12}}{1+1} = \sqrt{3}$

$\Rightarrow 2\beta = \pi/3 \Rightarrow \beta = \pi/6$

$\therefore (\alpha + \beta) = (45^\circ, 30^\circ)$

7. (b) L.H.S. =  $\frac{(\sin 3A \cos A)^2 - (\cos 3A \sin A)^2}{(\sin A \cos A)^2} =$

$\frac{4 \cdot [(\sin 3A \cos A - \cos 3A \sin A)(\sin 3A \cos A + \cos 3A \sin A)]}{2(\sin A \cos A)^2}$

$= \frac{4 \cdot \sin(2A) \cdot \sin(4A)}{(\sin 2A)^2}$

$= \frac{4 \cdot \sin(2A) \cdot 2 \sin(2A) \cdot \cos(2A)}{\sin^2(2A)} = 8 \cos(2A)$

8. (d) We know that  $\sin 3A = 3 \sin A - 4 \sin^3 A$

$\Rightarrow \sin^3 A = \frac{3 \sin A - \sin 3A}{4}$

$\therefore$  General Equation =

$\frac{1}{4} [3 \sin 10^\circ - \sin 30^\circ + 3 \sin 50^\circ - \sin 150^\circ + 3 \sin 70^\circ + \sin 210^\circ]$

$= \frac{1}{4} \left[ 3[\sin 10^\circ + \sin 50^\circ - \sin 70^\circ] - \frac{1}{2} - \frac{1}{2} - \frac{1}{2} \right]$

$= 3/4 [\sin 10^\circ + \sin 50^\circ - \sin 70^\circ] - 3/8 \dots (i)$

Also  $\sin 10^\circ + \sin 50^\circ - \sin 70^\circ$

$= 2 \sin(30^\circ) \cos(20^\circ) - \cos 20^\circ$

$= \cos 20^\circ - \cos 20^\circ = 0$

$\therefore$  General Solution =  $-3/8$

9. (c)  $f(\theta) = (\sin\theta + \operatorname{cosec}\theta)^2 + (\cos\theta + \sec\theta)^2 = \sin^2\theta + \operatorname{cosec}^2\theta + 2 + \cos^2\theta + \sec^2\theta + 2$

$= 5 + \frac{1}{\sin^2\theta} + \frac{1}{\cos^2\theta} = 5 + \frac{\cos^2\theta + \sin^2\theta}{(\sin\theta \cos\theta)^2} = 5 + \frac{4}{\sin^2(2\theta)}$

$f(\theta)$  is minimum when  $\sin(2\theta)$  is maximum.

$\therefore f(\theta)$  minimum =  $5 + \frac{4}{1} = 9$

Ans (c)

10. (c) Required equation will be  $x^2 - (\operatorname{cosec}^2\theta + \sec^2\theta)x + \operatorname{cosec}^2\theta \cdot \sec^2\theta = 0$

$\Rightarrow x^2 - \left(\frac{1}{\sin^2\theta} + \frac{1}{\cos^2\theta}\right)x + \frac{1}{\sin^2\theta} \cdot \frac{1}{\cos^2\theta} = 0$

$\Rightarrow x^2 - \left(\frac{1}{\sin^2\theta \cdot \cos^2\theta}\right)x + \frac{1}{\sin^2\theta \cdot \cos^2\theta} = 0$

$\Rightarrow x^2 - \frac{4x}{\sin^2 2\theta} + \frac{4}{\sin^2 2\theta} = 0 \dots (i)$

Equation (i) will be come as given in option (a), (b) and (c) for  $\sin^2\theta = 2, 4/3$  and  $4/5$  respectively. Out of which only  $4/5$  is possible. So,  $\operatorname{cosec}^2\theta$  and  $\sec^2\theta$  can be the roots of equation (c).

11. (d)  $\frac{\cos x}{a} = \frac{\sin x}{b} \Rightarrow \tan x = \frac{b}{a}$

$\Rightarrow \cos(2x) = \frac{1 - \tan^2 x}{1 + \tan^2 x} = \frac{1 - \frac{b^2}{a^2}}{1 + \frac{b^2}{a^2}} = \frac{a^2 - b^2}{a^2 + b^2}$  and

$\sin(2x) = \frac{2 \tan x}{1 + \tan^2 x} = \frac{2b}{a} \times \frac{a^2}{a^2 + b^2} = \frac{2ab}{a^2 + b^2}$

$\therefore |a \cos(2x) + b \sin(2x)| = \left| \frac{a[a^2 - b^2]}{a^2 + b^2} + \frac{b \cdot 2ab}{a^2 + b^2} \right| =$

$\left| \frac{a^3 - ab^2 + 2ab^2}{a^2 + b^2} \right| = \left| \frac{a^3 + ab^2}{a^2 + b^2} \right| = |a|$

$$\begin{aligned}
 12. \text{ (d)} \quad & \tan^2 x + \sec x - a = 0 \Rightarrow \sec^2 x - 1 + \sec x - a = 0 \\
 & \Rightarrow \sec^2 x + \sec x - (1 + a) = 0 \\
 & \Rightarrow \sec^2 x + \sec x = 1 + a \\
 & \text{L.H.S.} \geq 2 \quad \Rightarrow 1 + a \geq 2 \\
 & \Rightarrow a \geq -1 \\
 \therefore & a \in [-1, \infty)
 \end{aligned}$$

$$\begin{aligned}
 13. \text{ (c)} \quad & \sin^2 \theta = \frac{x^2 + y^2 + 1}{2x} \quad \Rightarrow 0 \leq \sin^2 \theta \leq 1 \\
 & \Rightarrow 0 \leq \frac{x^2 + y^2 + 1}{2x} \leq 1 \\
 & \Rightarrow x > 0 \quad \Rightarrow 0 \leq x^2 + y^2 + 1 \leq 2x \\
 & \Rightarrow 0 \leq x^2 + y^2 - 2x + 1 \leq 0 \\
 & \Rightarrow 0 \leq (x-1)^2 + y^2 \leq 0 \Rightarrow x = 1, y = 0
 \end{aligned}$$

$$\begin{aligned}
 14. \text{ (a)} \quad & \sin \theta + \operatorname{cosec} \theta = 2 \\
 & \Rightarrow \sin \theta = 1; \operatorname{cosec} \theta = 2 \\
 \therefore & \sin \theta = 1 \quad \Rightarrow \sin \theta + \operatorname{cosec} \theta = 2
 \end{aligned}$$

$$\begin{aligned}
 15. \text{ (a)} \quad & A = 130^\circ \text{ and } x = \sin A + \cos A \\
 & \Rightarrow x = \sin 130^\circ + \cos 130^\circ = \sin 130^\circ + \cos (90^\circ + 140^\circ) \\
 & = \sin 130^\circ - \sin 40^\circ = 2 \cos(85^\circ) \sin(45^\circ) \\
 & = 2 \frac{1}{\sqrt{2}} \cos(85^\circ) \\
 \therefore & x > 0.
 \end{aligned}$$

$$\begin{aligned}
 16. \text{ (a)} \quad & a = \frac{\pi}{18} \Rightarrow 18a = \pi \\
 & \Rightarrow a = \pi - 17a \\
 & \Rightarrow \cos a = \cos(\pi - 17a) = -\cos(17a) \\
 & \text{Similarly } \cos(2a) = -\cos(16a); \cos(3a) = -\cos(15a); \cos(8a) = -\cos(10a) \\
 \therefore & E = \cos 9(a) = \cos(\pi/2) = 0
 \end{aligned}$$

$$17. \text{ (c)} \quad \tan = \frac{x}{Am} \Rightarrow \frac{x}{Am} = \frac{x}{\tan A}$$

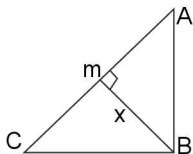

$$\text{Similarly } Cm = \frac{x}{\tan C}. \text{ Also } Am + Cm = 2\sqrt{2}x$$

$$\begin{aligned}
 \Rightarrow & 2\sqrt{2} = \frac{1}{\tan A} + \frac{1}{\tan C} \\
 \Rightarrow & \tan A + \tan C = 2\sqrt{2} \tan A \tan C \quad \dots\dots (i)
 \end{aligned}$$

$$\text{Also } A + C = \frac{\pi}{2} \Rightarrow \frac{\tan A + \tan C}{1 - \tan A \tan C} = \infty$$

$$\begin{aligned}
 \Rightarrow & \tan A \tan C = 1 \quad \dots (ii) \\
 \therefore & \text{ From (i) and (ii) we get, } \tan A + \tan C = 2\sqrt{2} \text{ and } \tan A \tan C = 1 \\
 & \text{Solving these two we get, } \tan A = \sqrt{2} - 1 \\
 \Rightarrow & A = \pi/8 \quad \therefore C = 3\pi/8
 \end{aligned}$$

$$\begin{aligned}
 18. \text{ (c)} \quad & E = (1 + \tan x + \tan^2 x)(1 - \cot x + \cot^2 x) \\
 & = (\sec^2 x + \tan x)(\operatorname{cosec}^2 x - \cot x) = \sec^2 x \operatorname{cosec}^2 x - \sec^2 x \cot x + \tan x \sec^2 x - 1 \\
 & = \frac{1}{\sin^2 x \cos^2 x} - 1 = \frac{4}{\sin^2 2x} - 1 \\
 \therefore & E \text{ is positive for all value } x
 \end{aligned}$$

$$\begin{aligned}
 19. \text{ (a)} \quad & \sin x + \sin^2 x = 1 \Rightarrow \sin x = 1 - \sin^2 x = \cos^2 x \\
 & \Rightarrow \sin x = \cos^2 x \quad \dots (i) \\
 & \text{Also } \sin x + \sin^2 x = 1, \text{ cubing both sides we get, } \sin^3 x + \sin^6 x + 3 \sin x \sin^2 x [\sin x + \sin^2 x] = 1 \\
 & \sin^3 x + \sin^6 x + 3 \sin^4 x + 3 \sin^5 x = 1 \\
 \Rightarrow & \cos^6 x + \cos^{12} x + 3 \cos^8 x + 3 \cos^{10} x = 1 \quad [\text{using (i)}]
 \end{aligned}$$

$$\begin{aligned}
 20. \text{ (b)} \quad & x = h + a \sec \theta \\
 \Rightarrow & \frac{x-h}{a} = \sec \theta \Rightarrow \cos \theta = \frac{a}{x-h} \\
 y = k + b \operatorname{cosec} \theta & \Rightarrow \frac{y-k}{b} = \operatorname{cosec} \theta \\
 \Rightarrow \sin \theta = & \frac{b}{y-k} \\
 \text{Also } \sin^2 \theta + \cos^2 \theta = & 1 \\
 \Rightarrow \frac{a^2}{(x-h)^2} + \frac{b^2}{(y-k)^2} = & 1
 \end{aligned}$$

$$\begin{aligned}
 21. \text{ (a)} \quad & \Delta = \begin{vmatrix} 0 & \sin B & \cos B \\ -\sin B & 0 & \tan A \\ \cos(A+C) & -\tan A & 0 \end{vmatrix} \\
 \Rightarrow & \Delta \text{ is a skew symmetric matrix of order 3.} \\
 \Rightarrow & \Delta = 0
 \end{aligned}$$

$$\begin{aligned}
 22. \text{ (d)} \quad & t_1 = \sin(\log_{10} 2) \\
 & t_2 = \sin(10 \log_{10} 3) \\
 & t_{10001} = \sin \log_{10} 10002. \text{ Which lies in third quadrant.} \\
 \therefore & t_{10001} \text{ is negative.}
 \end{aligned}$$

$$\begin{aligned}
 23. \text{ (b)} \quad & s_1 = \tan A + \tan B + \tan C = 7 \\
 & s_2 = 11, s_3 = 7 \\
 \tan(A+B+C) & = \frac{s_1 - s_3}{1 - s_2} = \frac{0}{1-11} = 0 \\
 \therefore & A + B + C = \pi \text{ or } 0
 \end{aligned}$$

$$\begin{aligned}
 24. \text{ (c)} \quad & \text{Given } a_{n+1} = \sqrt{\frac{1}{2}(1 + a_n)}. \text{ Let } a_0 = \cos \theta \\
 \Rightarrow & a_1 = \sqrt{\frac{1 + \cos \theta}{2}} = \cos \frac{\theta}{2} \\
 \Rightarrow & a_2 = \sqrt{\frac{1}{2}(1 + a_1)} = \cos \left( \frac{\theta}{4} \right) \\
 & \text{Similarly } a_3 = \cos \left( \frac{\theta}{8} \right) \text{ so on} \\
 \Rightarrow & a_{n+1} = \cos \left( \frac{\theta}{2^{n+1}} \right)
 \end{aligned}$$

1.124 > Trigonometry

Now we know that

$$\cos\left(\frac{\theta}{2}\right)\cos\left(\frac{\theta}{2^2}\right)\cos\left(\frac{\theta}{2^3}\right)\dots\cos\left(\frac{\theta}{2^{n-1}}\right)\dots\infty = \frac{\sin\theta}{\theta}$$

$$\Rightarrow \cos\left(\frac{\sqrt{1-a_0^2}}{a_1, a_2, \dots, \infty}\right) = \cos\left(\frac{\sin\theta}{\sin\theta}\right) = \cos\theta = a_0$$

25. (a)  $a \sin x + b \cos(x + \theta) + b \cos(x - \theta) = d$   
 $\Rightarrow a \sin x + b [2\cos\theta \cos x] = d$   
 $\Rightarrow a \sin x + 2b \cos\theta \cos x = d$

We know that  $a \sin x + b \cos x = c$  has a solution if  $|c| \leq \sqrt{a^2 + b^2}$

$$\therefore |d| \leq \sqrt{a^2 \sin^2 x + 4b^2 \cos^2 \theta \cos^2 x}$$

$$\Rightarrow \frac{d^2 - a^2 \sin^2 x}{4b^2 \cos^2 \theta} \leq \cos^2 \theta \Rightarrow \cos^2 \theta \geq \frac{d^2 - a^2 \sin^2 x}{4b^2 \cos^2 x}$$

$$\Rightarrow \cos\theta \geq \frac{\sqrt{d^2 - a^2}}{2|b|} \geq \frac{1}{2|b|} \sqrt{d^2 - a^2}$$

26. (d)

$$f(x) = (2\cos x - 1)\left(\sin x - \frac{1}{2}\right)(\sin x - \cos x)\left(\cot x - \frac{1}{\sqrt{3}}\right) > 0$$

$$\Rightarrow (2\cos x - 1)\left(\sin x - \frac{1}{2}\right)\sqrt{2}\left(\sin\left(x - \frac{\pi}{4}\right)\right)$$

$$\left[\frac{\cos x}{\sin x} - \frac{\cos \frac{\pi}{3}}{\sin \frac{\pi}{3}}\right] > 0$$

$$\Rightarrow (2\cos x - 1)\left(\sin x - \frac{1}{2}\right)\sqrt{2}\sin\left(x - \frac{\pi}{4}\right)\frac{\left[\sin\left(\frac{\pi}{3} - x\right)\right]}{\sin x \sin \frac{\pi}{3}} > 0$$

$$\Rightarrow (2\cos x - 1)\left(\sin x - \frac{1}{2}\right)\sin\left(x - \frac{\pi}{4}\right)\left(\sin\left(\frac{\pi}{3} - x\right)\right) > 0$$

( $\because$  In  $(0, \pi)$ ,  $\sin x, \sin \frac{\pi}{3} > 0$ )

$$\Rightarrow -f(x) = (2\cos x - 1)\left(\sin x - \frac{1}{2}\right)\sin\left(x - \frac{\pi}{4}\right)\sin\left(\frac{\pi}{3} - x\right) < 0$$

In interval  $\left(0, \frac{\pi}{6}\right)$ ,  $f(x) > 0$ ;

In interval  $\left(\frac{\pi}{6}, \frac{\pi}{4}\right)$ ,  $f(x) < 0$ ;

In interval  $\left(\frac{\pi}{4}, \frac{\pi}{3}\right)$ ,  $f(x) > 0$

In interval  $\left(\frac{\pi}{3}, \frac{\pi}{2}\right)$ ,  $f(x) > 0$ ;

In interval  $\left[\frac{\pi}{2}, \frac{5\pi}{6}\right)$ ,  $f(x) > 0$ ;

In interval  $\left(\frac{5\pi}{6}, \pi\right)$ ,  $f(x) < 0$

$\therefore$  From above  $f(x) > 0$  for  $x \in \left(0, \frac{\pi}{6}\right) \cup \left(\frac{\pi}{4}, \frac{\pi}{3}\right) \cup \left(\frac{\pi}{3}, \frac{5\pi}{6}\right)$

27. (b)  $0 < \alpha < \beta < \gamma < \frac{\pi}{2}$

( $\because$   $\sin\theta$  is increasing function in  $\left(0, \frac{\pi}{2}\right)$ )

$$\Rightarrow 0 < \sin \alpha < \sin \beta < \sin \gamma < 1$$

$$\Rightarrow 3\sin \alpha < \sin \alpha + \sin \beta + \sin \gamma < 3\sin \gamma \quad \dots(i)$$

Also  $\cos\theta$  is decreasing function in  $\left(0, \frac{\pi}{2}\right)$

$$\Rightarrow 1 > \cos \alpha > \cos \beta > \cos \gamma > 0$$

$$\Rightarrow 3\cos \alpha > \cos \alpha + \cos \beta + \cos \gamma > 3\cos \gamma$$

$$\Rightarrow \frac{1}{3\cos \alpha} < \frac{1}{\cos \alpha + \cos \beta + \cos \gamma} < \frac{1}{3\cos \gamma}$$

From Equation (i) and (ii) gives

$$\tan \alpha < \left(\frac{\sin \alpha + \sin \beta + \sin \gamma}{\cos \alpha + \cos \beta + \cos \gamma}\right) < \tan \gamma$$

28. (d)  $\sin^2 A + \sin^2 B - \sin^2 C =$

$$\frac{1 - \cos 2A}{2} + \frac{1 - \cos 2B}{2} - \left[\frac{1 - \cos 2C}{2}\right]$$

$$= \frac{1}{2} - \frac{1}{2}[\cos 2A + \cos 2B - \cos 2C] \quad \dots(i)$$

Now  $\cos 2A + \cos 2B - \cos 2C = 2\cos(A+B)\cos(A-B) - [2\cos^2 C - 1]$

$$= 1 - 2\cos C \cos(A-B) - 2\cos^2 C = 1 - 2\cos C [\cos(A-B) + \cos C]$$

$$= 1 - 2\cos C \cdot 2\sin A \sin B = 1 - 4\sin A \sin B \cos C$$

$\Rightarrow$  from (i);  $\sin^2 A + \sin^2 B - \sin^2 C$

$$= \frac{1}{2} - \frac{1}{2} + 2\sin A \sin B \cos C = 2\sin A \sin B \cos C$$

29. (b) General solution =  $\sin^2 \frac{A}{2} + \sin^2 B + \sin^2 \frac{C}{2}$

$$= \frac{1 - \cos A}{2} + \frac{1 - \cos B}{2} + \frac{1 - \cos C}{2}$$

$$= \frac{3}{2} - \frac{1}{2}[\cos A + \cos B + \cos C]$$

$$= \frac{3}{2} - \frac{1}{2}[1 + 4\sin(A/2)\sin(B/2)\sin(C/2)]$$

$$= 1 - 2\sin(A/2)\sin(B/2)\sin(C/2).$$

30. (a)  $x^2 - px + q = 0$  has  $\tan A$  and  $\tan B$  as its roots

$$\Rightarrow \tan A + \tan B = p \quad \dots(i)$$

$$\text{and } \tan A \tan B = q \quad \dots(ii)$$

$$\text{Also } \tan(A+B) = \frac{\tan A + \tan B}{1 - \tan A \tan B} = \frac{p}{1 - q}$$

$$\Rightarrow \sec^2(A+B) = 1 + \tan^2(A+B)$$

$$= 1 + \frac{p^2}{(1-q)^2} = \frac{(1-q)^2 + p^2}{(1-q)^2}$$

$$\therefore \cos^2(A+B) = \frac{(1-q)^2}{p^2 + (1-q)^2}$$

$$\Rightarrow 1 - \sin^2(A+B) = \frac{(1-q)^2}{p^2 + (1-q)^2}$$

$$\Rightarrow \sin^2(A+B) = 1 - \frac{(1-q)^2}{p^2 + (1-q)^2} = \frac{p^2}{p^2 + (1-q)^2}$$

31. (d)  $\cos A = -3/5$

$$\sin^2 A = 1 - \frac{9}{25} = \frac{16}{25} \Rightarrow \sin A = 4/5$$

$$\tan A = -4/3$$

$$S = \sin A + \tan A = \frac{4}{5} - \frac{4}{3} = \frac{12 - 20}{15} = \frac{-8}{15}$$

$$P = \sin A \tan A = -\frac{16}{15}$$

$$\therefore \text{Required equation } x^2 - \left(-\frac{8}{15}\right)x - \frac{16}{15} = 0$$

$$\Rightarrow 15x^2 + 8x - 16 = 0.$$

32. (b)  $\cos^2\left(\frac{A}{2}\right) + \cos^2\left(\frac{B}{2}\right) + \cos^2\left(\frac{C}{2}\right)$

$$= \frac{1 + \cos A}{2} + \frac{1 + \cos B}{2} + \frac{1 + \cos C}{2}$$

$$= \frac{3}{2} + \frac{1}{2} [\cos A + \cos B + \cos C]$$

$$= \frac{3}{2} + \frac{1}{2} [1 + 4\sin(A/2) \sin(B/2) \sin(C/2)]$$

$$= 2 + 2 \sin(A/2) \sin(B/2) \sin(C/2)$$

33. (a)  $\sin^2(A/2) + \sin^2(B/2) - \sin^2(C/2)$

$$= \frac{1 - \cos A}{2} + \frac{1 - \cos B}{2} - \left(\frac{1 - \cos C}{2}\right)$$

$$= \frac{1}{2} - \frac{1}{2} [\cos A + \cos B - \cos C] \quad \dots (i)$$

$$\text{Now } \cos A + \cos B - \cos C$$

$$= 2 \cos\left(\frac{A+B}{2}\right) \cos\left(\frac{A-B}{2}\right) - \cos C$$

$$= 2 \sin\left(\frac{C}{2}\right) \cos\left(\frac{A-B}{2}\right) - \left[1 - 2 \sin^2\left(\frac{C}{2}\right)\right]$$

$$= -1 + 2 \sin(C/2) \left[ \cos\left(\frac{A-B}{2}\right) + \sin\left(\frac{C}{2}\right) \right]$$

$$= -1 + 2 \sin(C/2) \left[ \cos\left(\frac{A-B}{2}\right) + \cos\left(\frac{A+B}{2}\right) \right]$$

$$= -1 + 2 \sin(C/2) \cdot 2 \cos\left(\frac{A}{2}\right) \cos\left(\frac{B}{2}\right)$$

$$= -1 + 4 \cos(A/2) \cos(B/2) \sin(C/2)$$

$$\therefore \text{from (1) given expression} = 1 - 2 \cos(A/2) \cos(B/2) \sin(C/2)$$

34. (b)  $\sin A - \sqrt{6} \cos A = \sqrt{7} \cos A$

$$\Rightarrow \sin A = (\sqrt{7} + \sqrt{6}) \cos A$$

$$\Rightarrow \frac{\cos A}{\sin A} = \frac{1}{\sqrt{7} + \sqrt{6}} \times \frac{\sqrt{7} - \sqrt{6}}{\sqrt{7} - \sqrt{6}} = \sqrt{7} - \sqrt{6}$$

$$\Rightarrow \cos A = (\sqrt{7} - \sqrt{6}) \sin A$$

$$\Rightarrow \cos A + \sqrt{6} \sin A = \sqrt{7} \sin A$$

35. (b)  $\sin^2 A + \sin^2 B + \sin^2 C - 2 \cos A \cos B \cos C = 2 + 2 \cos A \cos B \cos C - 2 \cos A \cos B \cos C = 2$

36. (c)  $\sqrt{\cos^2 \alpha + 2 \cot \alpha} = \sqrt{1 + \cot^2 \alpha + 2 \cot \alpha} = |1 + \cot \alpha|$   
 $\frac{3\pi}{4} < \alpha < \pi$  and  $\cot \alpha$  is decreasing

$$\Rightarrow \cos \alpha < -1 \quad \Rightarrow 1 + \cot \alpha < 0$$

$$\Rightarrow |1 + \cot \alpha| = -1 - \cot \alpha$$

37. (d)  $\cos A = \cos B \cos C \quad A + B + C = \pi$

$$\cos(B + C) = \cos(\pi - A) \quad B + C = \pi - A$$

$$\Rightarrow \cos B \cos C - \sin B \sin C = -\cos A$$

$$\Rightarrow \cos B \cos C + \cos A = \sin B \sin C$$

$$\Rightarrow 2 \cos B \cos C = \sin B \sin C$$

$$\Rightarrow \cot B \cot C = 1/2$$

38. (b)  $x = X \cos \theta - Y \sin \theta \quad \dots (i)$

$$y = X \sin \theta + Y \cos \theta \quad \dots (ii)$$

$$x^2 + 4xy + y^2 = AX^2 + BY^2$$

$$\text{Squaring and adding (1) and (2) we get, } x^2 + y^2 = X^2 + Y^2$$

$$xy = XY \cos^2 \theta + x^2 \cos \theta \sin \theta - Y^2 \cos \theta \sin \theta - XY \sin^2 \theta$$

$$= XY(\cos^2 \theta - \sin^2 \theta) + \cos \theta \sin \theta (X^2 - Y^2)$$

$$\text{Putting in the equation, } X^2(1 + 4 \cos \theta \sin \theta) + Y^2(1 - 4 \cos \theta \sin \theta) + 4XY(\cos^2 \theta - \sin^2 \theta)$$

$$\Rightarrow \text{On comparison of coefficient, } A = 3, \theta = \frac{\pi}{4}$$

39. (b)  $\sin^n x + \cos^n x \geq 1$

$$\text{Using A.M. and GM } \frac{\sin^n x + \cos^n x}{2} \geq \sqrt{\sin^n x \cos^n x}$$

$$\geq 2 \sqrt{\frac{2(\sin x \cos x)^n}{2^n}} \geq \sqrt{2^{2-n} \sin^n(2x)}$$

$$\therefore 2^{2-n} \geq 1 \quad \Rightarrow 2 - n \geq 0$$

$$\Rightarrow n \leq 2$$

40. (b)  $\cos\left(\alpha + \frac{\pi}{2}\right) = -\sin \alpha$

$$\text{Similarly } \cos\left(\beta + \frac{\pi}{2}\right) = -\sin \beta \quad \text{and} \quad \cos\left(\gamma + \frac{\pi}{2}\right) = -\sin \gamma$$

$$\therefore \text{Required area} = \frac{-[\sin \alpha + \sin \beta + \sin \gamma]}{3}$$

$$\text{Now } \frac{\sin \alpha + \sin \beta + \sin \gamma}{3} \geq 3 \sqrt{\sin \alpha \sin \beta \sin \gamma}$$

$$\text{Equality holds, if } A = B = C$$

$$\therefore \text{Minimum value} = \left[\left(\frac{\sqrt{3}}{2}\right)^3\right]^3$$

$$\therefore \text{Required minimum value} = \frac{-\sqrt{3}}{2}$$

41. (c)  $x + \frac{1}{x} = 2 \cos \alpha, y + \frac{1}{y} = 2 \cos \beta, z + \frac{1}{z} = 2 \cos \gamma$

$\therefore x^2 - 2 \cos \alpha x + 1 = 0$   
 $\Rightarrow x = \cos \alpha \pm i \sin \alpha = \text{cis } \alpha$ . Similarly  $y = \text{cis } \beta, z = \text{cis } \gamma$ .  
 Also  $x + y + z = xyz$   
 $\Rightarrow \Sigma \cos \alpha = \cos(\alpha + \beta + \gamma)$   
 $\Sigma \sin \alpha = \sin(\alpha + \beta + \gamma)$   
 Squaring and adding we get,  $(\Sigma \cos \alpha)^2 + (\Sigma \sin \alpha)^2 = 1$   
 $\Rightarrow \cos^2 \alpha + \cos^2 \beta + \cos^2 \gamma + 2 \cos \alpha \cos \beta + 2 \cos \beta \cos \gamma + 2 \cos \gamma \cos \alpha + \sin^2 \alpha + \sin^2 \beta + \sin^2 \gamma + 2 \sin \alpha \sin \beta + 2 \sin \beta \sin \gamma + 2 \sin \gamma \sin \alpha = 1$   
 $\Rightarrow 3 + 2 [\Sigma \cos(\alpha - \beta)] = 1$   
 $\therefore \Sigma \cos(\alpha - \beta) = -1$

42. (b)  $p \sin(2\theta) + (q-1) \cos(2\theta) + (q+1) = 0$   
 $p \frac{2 \tan \theta}{1 + \tan^2 \theta} + (q-1) \frac{1 - \tan^2 \theta}{1 + \tan^2 \theta} + (q+1) = 0$   
 $\Rightarrow 2p \tan \theta + (q-1)(1 - \tan^2 \theta) + (q+1)(\tan^2 \theta + 1) = 0$   
 $\Rightarrow \tan^2 \theta + p \tan \theta + q = 0 \dots (i)$   
 Since  $\alpha, \beta$  are roots of (i)  
 $\tan \alpha + \tan \beta = -p, \tan \alpha \tan \beta = q$   
 Also  $\tan(\alpha + \beta) = \frac{-p}{1-q} = \frac{p}{q-1}$

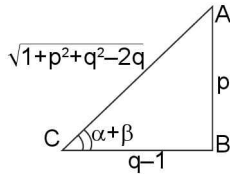

$\therefore \sin^2(\alpha + \beta) + p \sin(\alpha + \beta) \cos(\alpha + \beta) + q \cos^2(\alpha + \beta)$   
 $\therefore \frac{(q-1)^2}{p^2 + (q-1)^2} + \frac{p \cdot p(q-1)}{p^2 + (q-1)^2} + \frac{q \cdot (q-1)^2}{p^2 + (q-1)^2} = q$

43. (a)  $\text{cosec } \theta = \frac{1}{\sin \theta} = \frac{\sin\left(\frac{\theta}{2}\right)}{\sin\left(\frac{\theta}{2}\right) \sin \theta}$   
 $= \frac{\sin\left(\frac{\theta}{2}\right)}{\sin\left(\frac{\theta}{2}\right) \sin \theta} = \frac{\sin \theta \cos \frac{\theta}{2} - \cos \theta \sin \frac{\theta}{2}}{\sin\left(\frac{\theta}{2}\right) \sin \theta}$   
 $= \cot(\theta/2) - \cot \theta$   
 Similarly replace  $\theta$  by  $2\theta, 4\theta, \dots$ ,  
 $\Rightarrow \text{cosec}(2\theta) = \cot(\theta) - \cot(2\theta)$   
 $\text{cosec}(4\theta) = \cot(2\theta) - \cot(4\theta)$   
 Thus  $n^{\text{th}}$  term of the series is  $\cot(2^{n-2}\theta) - \cot(2^{n-1}\theta)$   
 $\Rightarrow$  Required sum of the series can be found by adding the terms  
 $S = \left[ \cot\left(\frac{\theta}{2}\right) - \cot \theta \right] + [\cot \theta - \cot(2\theta)] + [\cot(2\theta) - \cot(4\theta)]$   
 $+ \dots + \left[ \cot \frac{2^{n-2}}{\theta} - \cot 2^{n-1} \theta \right]$

$S = \cot\left(\frac{\theta}{2}\right) - \cot(2^{n-1}\theta)$

$\Rightarrow k = n - 1$

44. (a) Given  $\sin A \cdot \sin B \cdot \sin C = p \dots (i)$   
 And  $\cos A \cdot \cos B \cdot \cos C = q \dots (ii)$

Dividing (i) by (ii) we get,  $\tan A \cdot \tan B \cdot \tan C = p/q$   
 Also in a  $\Delta$ ,  $\tan A + \tan B + \tan C = \tan A \cdot \tan B \cdot \tan C$   
 $\Rightarrow S_1 = S_3 = p/q$   
 Now  $S_2 = \tan A \cdot \tan B + \tan B \cdot \tan C + \tan C \cdot \tan A$   
 $= \frac{\sin A \sin B}{\cos A \cos B} + \frac{\sin B \sin C}{\cos B \cos C} + \frac{\sin C \sin A}{\cos C \cos A}$   
 $= \frac{\sin A \sin B}{\cos A \cos B} + \left[ \frac{(\cos A \sin B + \sin A \cos B) \sin C}{\cos A \cos B \cos C} \right]$

$A + B + C = \pi$   
 $A + B = \pi - C$   
 $\Rightarrow \sin(A + B) = \sin C = \frac{\sin A \sin B}{\cos A \cos B} + \frac{\sin C \sin(A + B)}{\cos A \cos B \cos C}$   
 $= \frac{\sin A \sin B}{\cos A \cos B} + \frac{\sin^2 C}{\cos A \cos B \cos C}$   
 $= \frac{\sin A \sin B \cos C + \sin^2 C}{q}$   
 $= \frac{\sin A \sin B \cos C + 1 - \cos^2 C}{q}$   
 $= \frac{\cos C [-\cos C + \sin A \sin B] + 1}{q}$   
 $= \frac{\cos C [\cos(A + B) + \sin A \sin B] + 1}{q}$   
 $= \frac{\cos C [\cos A + \cos B] + 1}{q} = \left(1 + \frac{1}{q}\right) = \frac{q+1}{q}$

$\therefore$  The required cubic equation  $x^3 - S_1 x^2 + S_2 x - S_3 = 0$   
 $\Rightarrow x^3 - \left(\frac{p}{q}\right)x^2 + \left(\frac{q+1}{q}\right)x - \left(\frac{p}{q}\right) = 0$   
 $\Rightarrow qx^3 - px^2 + (q+1)x - p = 0$

45. (a)  $2 \sin\left(\frac{A}{2}\right) \text{cosec}\left(\frac{B}{2}\right) \sin\left(\frac{C}{2}\right) - \sin A \cot\left(\frac{B}{2}\right) - \cos A$   
 $= \frac{2 \sin\left(\frac{A}{2}\right) \sin\left(\frac{C}{2}\right)}{\sin\left(\frac{B}{2}\right)} - \frac{\cos\left(\frac{B}{2}\right) \sin A}{\sin\left(\frac{B}{2}\right)} - \cos A$   
 $= \frac{2 \sin\left(\frac{A}{2}\right) \sin\left(\frac{C}{2}\right) - \cos\left(\frac{B}{2}\right) \sin A}{\sin\left(\frac{B}{2}\right)} - \cos A$   
 $= \frac{2 \sin\left(\frac{A}{2}\right) \left[ \sin\left(\frac{C}{2}\right) - \cos\left(\frac{A}{2}\right) \cos\left(\frac{B}{2}\right) \right] - \cos A}{\sin\left(\frac{B}{2}\right)}$

$$[\because A+B+C = \pi \Rightarrow \frac{C}{2} = \frac{\pi}{2} - \left(\frac{A+B}{2}\right)]$$

$$\Rightarrow \sin\left(\frac{C}{2}\right) = \cos(A+B/2)$$

$$\Rightarrow \text{L.H.S.} = \frac{2\sin\left(\frac{A}{2}\right)\left[\cos\left(\frac{A+B}{2}\right) - \cos\left(\frac{A}{2}\right)\cos\left(\frac{B}{2}\right)\right]}{\sin\left(\frac{B}{2}\right)} - \cos A$$

$$= \frac{-2\sin\left(\frac{A}{2}\right)\left[\sin\left(\frac{A}{2}\right)\sin\left(\frac{B}{2}\right)\right]}{\sin\left(\frac{B}{2}\right)} - \cos A$$

$$= -2\sin^2(A/2) - \cos A = -2\sin^2(A/2) - [1 - 2\sin^2(A/2)] = -1$$

46. (b) Applying AM ≥ GM for 6tan<sup>2</sup>θ + 54 cotθ
- $$\frac{6\tan^2\theta + 54\cot^2\theta}{2} \geq \sqrt{6 \times 54}$$
- 6tan<sup>2</sup>θ + 54 cot<sup>2</sup>θ ≥ 36
- ∴ 6tan<sup>2</sup>θ + 54 cot<sup>2</sup>θ + 18 ≥ 54
- Equality holds if 6tan<sup>2</sup>θ = 54 cot<sup>2</sup>θ = 18
- ∴ tan<sup>2</sup>θ = 3 and cot<sup>2</sup>θ = 1/3
- ∴ AM ≥ GM can be applied to 6tan<sup>2</sup>θ, 54 cotθ and 18 also
- So statement I and II both are correct.

47. (c) f(x) = cos x + 1/2 cos(2x) - 1/3 cos(3x)

$$= \cos x + \frac{1}{2}[2\cos^2 x - 1] - \frac{1}{3}[4\cos^3 x - 3\cos x]$$

$$= -\frac{4}{3}\cos^3 x + \cos^2 x + 2\cos x - \frac{1}{2}$$

Let cos x = t

$$\therefore f(x) = -\frac{4}{3}t^3 + t^2 + 2t - \frac{1}{2}$$

$$\Rightarrow f'(t) = -4t^2 + 2t + 2$$

$$\Rightarrow f'(t) = 0, \text{ gives } t = -1/2, 1$$

$$\Rightarrow f''(t) = -8t + 2$$

∴ f''(1) < 0, f''(-1/2) > 0

∴ t = -1/2 is period of maxima

t = 1 is point of minima

$$\therefore f(t)_{\max} = -\frac{4}{3} \times \frac{-1}{8} + \frac{1}{4} - 1 - \frac{1}{2}$$

$$= \frac{1}{6} + \frac{1}{4} - \frac{3}{2} = \frac{2+3-18}{12} = -\frac{13}{12}$$

$$\therefore f(t)_{\min} = -\frac{4}{3} + 1 + 2 - \frac{1}{2} = 3 - \frac{4}{3} - \frac{1}{2} = \frac{18-8-3}{6} = \frac{7}{6}$$

∴ Require difference = 7/6 + 13/12 = 14+13/12 = 27/12 = 9/4

48. (a)  $\frac{\cot A + \cot B}{\tan A + \tan B} = \frac{\cos A \cos B}{\sin A \sin B} = \cot A \cot B$

$$\Rightarrow \sum \frac{\cot A + \cot B}{\tan A + \tan B} = \sum \cot A \cot B = 1$$

49. (a) Σxy = 1

$$\Rightarrow xy + yz + zx = 1 \Rightarrow x[y+z] = 1 - yz$$

$$\Rightarrow x = \frac{1-yz}{y+z} \Rightarrow \frac{1}{x} = \frac{y+z}{1-yz} \dots\dots(i)$$

Let x = tanA, y = tanB, z = tanC

∴ From (i),  $\cot A = \frac{\tan B + \tan C}{1 - \tan B \tan C}$

$$\Rightarrow \sum \frac{x+y}{1-xy} = \cot A + \cot B + \cot C$$

$$= \frac{1}{\tan A} + \frac{1}{\tan B} + \frac{1}{\tan C} = \frac{\Sigma xy}{\tan A \tan B \tan C} = \frac{1}{xyz}$$

50. (b)  $\theta \in \left(0, \frac{\pi}{4}\right)$

$t_1 = (\tan\theta)^{\tan\theta}, t_2 = (\tan\theta)^{\cot\theta}, t_3 = (\cot\theta)^{\tan\theta}, t_4 = (\cot\theta)^{\cot\theta}$

For  $\theta \in \left(0, \frac{\pi}{4}\right)$ ; tan θ is an increasing functions and

cotθ is decreasing function

∴ Let tanθ = 1 - k<sub>1</sub> (k<sub>1</sub> > 0, k → 0)

cotθ = 1 + k<sub>2</sub> (k<sub>2</sub> > 0, k<sub>2</sub> → 0)

Where k<sub>1</sub> and k<sub>2</sub> are small positive real numbers.

$t_1 = (\tan\theta)^{1-k_1}, t_2 = (\tan\theta)^{1+k_2}$

∴  $t_1 > t_2$

$t_3 = (\cot\theta)^{1-k_1}, t_4 = (\cot\theta)^{1+k_2}$

$t_3 < t_4 \Rightarrow t_4 > t_3$

Also  $t_3 = (\cot\theta)^{1-k_1}, t_1 = (\tan\theta)^{1-k_1}$

∴  $t_3 > t_1$

∴  $t_4 > t_3 > t_1 > t_2$

51. (b)  $t_1 = (\sin\theta)^{\csc\theta}, t_2 = (\csc\theta)^{\sin\theta}$

$t_3 = (\sin\theta)^{\sin\theta}, t_4 = (\csc\theta)^{\csc\theta}$

log<sub>t</sub> = cosecθ log (sinθ) ... (i)

log<sub>t</sub> = sinθ log (cosecθ) = sinθ  $\left[\log\left(\frac{1}{\sin\theta}\right)\right]$

= - sinθ log sinθ ... (ii)

log t<sub>3</sub> = sinθ log (sinθ) ... (iii)

log t<sub>4</sub> = cosecθ log (cosecθ) = - cosecθ log (sinθ)...(iv)

Now log (sinθ) < 0

⇒ From (i) and (ii), log 1/2 > log t<sub>1</sub>

⇒ t<sub>2</sub> > t<sub>1</sub>

⇒ From (ii) and (iv), cosecθ > sinθ

⇒ log t<sub>4</sub> > log t<sub>2</sub> ⇒ t<sub>4</sub> > t<sub>2</sub>

⇒ From (i) and (iii), log t<sub>3</sub> > log t<sub>1</sub>

⇒ t<sub>3</sub> > t<sub>1</sub>

Also from (ii) and (iii), t<sub>4</sub> > t<sub>2</sub> > t<sub>3</sub> > t<sub>1</sub>

52. (c)  $\theta \in \left(0, \frac{\pi}{4}\right) \Rightarrow \sin\theta < 1, \cos\theta < 1$

Also cosθ > sinθ

$t_1 = (\sin\theta)^{\cos\theta}$

⇒ log(t<sub>1</sub>) = cos (log sinθ) ... (i)

$t_2 = (\cos\theta)^{\cos\theta}$

⇒ log<sub>1/2</sub> = cosθ log (cosθ) ... (ii)

$t_3 = (\sin\theta)^{\sin\theta}$



1.128 > Trigonometry

$$\Rightarrow \log(t_3) = \sin\theta \log(\sin\theta) \dots\dots (iii)$$

$$t_4 = (\cos\theta)^{\sin\theta}$$

$$\Rightarrow \log t_4 = \sin\theta \log(\cos\theta) \dots\dots (iv)$$

Since  $\log(\sin\theta) < 0$ ,  $\log(\cos\theta) < 0$  and  $\log x$  is an increasing function

$\therefore$  From (ii) and (iv)  $\log t_4 > \log t_2$

$\Rightarrow t_4 > t_2$

From (i) and (iii),  $t_3 > t_1$

Also  $\log(\cos\theta) > \log(\sin\theta)$

$\Rightarrow t_2 > t_3 \quad \therefore t_4 > t_2 > t_3 > t_1$

53. (d) Given  $OC = 10$ ,  $OY = b = 10 - a$   
 $CD = 2a$ ,  $CY = a$

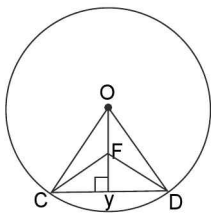

In  $\triangle OCY = (2b)^2 + a^2 = 100$

$$\Rightarrow 4b^2 + (10 - b)^2 = 100$$

$$\Rightarrow b = 4 \quad a = 6$$

$\therefore CF = \sqrt{16 + 36} = \sqrt{52} = 7.21$  km

$\therefore$  Perimeter of  $\triangle CDF = 7.21 + 10$  (km)

$\therefore$  Time taken =  $\frac{7.21 \times 10}{10} = 7.21$  Hrs.

**SECTION-IV (MORE THAN ONE CORRECT ANSWER)**

1. (a, c) (a)  $\frac{1 + \sin x}{\cos x(1 + \operatorname{cosec} x)} = \tan x$
- $\therefore$  Period is  $\pi$ .
- (b) Period of  $|\sin x| + |\cos x|$  is  $\pi/2$
- (c) Period of  $\sin(2x) + \cos(2x) = \text{L.C.M. of } \frac{2\pi}{2} \text{ and } \frac{2\pi}{2} \text{ i.e., } \pi$
2. (a, d)  $\cos^2 x + \frac{1}{\cos^2 x} \geq 2$  equality holds if  $\cos^2 x = 1$
- $\cos x = \pm 1$
- $\therefore x$  may be multiple of  $\pi$ .
- Again  $1 + \tan^2(2y) \geq 1$  equality hold if  $\tan 2y = 1$
- $\therefore y$  may be multiple of  $\pi/2$ .
3. (a, b, d)  $\frac{\cos^4 A}{\cos^2 B} + \frac{\sin^4 A}{\sin^2 B} = 1$
- $$\cos^4 A \sin^2 B + \sin^4 A \cos^2 B = \cos^2 B \sin^2 B$$
- $$(1 - \sin^2 A)^2 \sin^2 B + \sin^4 A (1 - \sin^2 B) = (1 - \sin^2 B) \sin^2 B$$
- $$\Rightarrow \sin^2 B + \sin^4 A \sin^2 B - 2\sin^2 A \sin^2 B + \sin^4 A - \sin^4 A \sin^2 B = \sin^2 B - \sin^4 B$$
- $$\Rightarrow \sin^4 A + \sin^2 B - 2\sin^2 A \sin^2 B = 0$$
- $\therefore$  **option (a)**
- $\Rightarrow \sin^2 A = \sin^2 B \quad \dots\dots\dots (i)$

$$\Rightarrow \cos^2 A = \cos^2 B \quad \dots\dots\dots (ii)$$

$$\text{L.H.S.} = \frac{\cos^4 B}{\cos^2 B} + \frac{\sin^4 B}{\sin^2 B} = \frac{\cos^4 B}{\cos^2 B} + \frac{\sin^4 B}{\sin^2 B}$$

[Using (i) and (ii)]

$$= \cos^2 B + \sin^2 B = 1 \quad \therefore \text{option (b)}$$

Similarly we can see that  $\therefore$  **option (d)**

4. (b, c)  $\tan\left(\frac{x}{2}\right) = \operatorname{cosec} x - \sin x = \tan\left(\frac{x}{2}\right) = \frac{1}{\sin x} - \sin x$

Use  $\sin(x) = \frac{2 \tan(x/2)}{1 + \tan^2(x/2)}$  and let  $\tan(x/2) = t$

$\therefore$  General equation becomes  $t = \frac{1+t^2}{2t} - \frac{2t}{1+t^2}$

After simplification we get,  $t^4 + 4t^2 - 1 = 0$

$\Rightarrow t^2 = -2 \pm \sqrt{5}$ , But  $t^2 \geq 0$

$\Rightarrow t^2 = \sqrt{5} - 2$

$\tan^2(x/2) = \sqrt{5} - 2$

Also  $\tan^2(x/2) = \frac{(\sqrt{5}-2)^2}{(\sqrt{5}-2)} \times \frac{\sqrt{5}+2}{\sqrt{5}+2}$

$= (9 - 4\sqrt{5})(2 + \sqrt{5})$

**Aliter:**  $\tan^2(x/2) \geq 0$

$\therefore$  Only option (b) and (c) are positive.

5. (b, c, d)  $a > b > 0$

$y = a \operatorname{cosec} \theta - b \cot \theta$

$\Rightarrow y + b \cot \theta = a \operatorname{cosec} \theta$

Squaring both sides we get,  $y^2 + b^2 + \cot^2 \theta + 2by \cot \theta = a^2 [1 + \cot^2 \theta]$

$\Rightarrow (b^2 - a^2) \cot^2 \theta + 2by \cot \theta + y^2 - a^2 = 0$

Since  $\cot \theta \in \mathbb{R}$

$\Rightarrow D \geq 0$

$4b^2 y^2 - 4 [y^2 - a^2] [b^2 - a^2] \geq 0$

$\Rightarrow a^2 y^2 + a^2 b^2 - a^4 \geq 0$

$\Rightarrow y^2 \geq a^2 - b^2$

$\Rightarrow |y| \geq \sqrt{a^2 - b^2}$

$\therefore$  Minimum value of  $y$  is  $\sqrt{a^2 - b^2}$

Also  $y = 0$ , if a  $\operatorname{cosec} \theta = b \cot \theta$

$\Rightarrow a = b \operatorname{cosec} \theta \quad \Rightarrow \cos \theta = \frac{a}{b}$

But  $a > b \quad \Rightarrow \cos \theta > 1$  which is impossible

$\therefore y = 0$  for any value of  $\theta$

Also

$\sqrt{a^2 - b^2} = \sqrt{(a-b)(a+b)} > \sqrt{(a-b)(a-b)} > (a-b)$

$\therefore y$  can't be  $a - b$  for any value of  $\theta$

6. (b, c)  $\tan x = \frac{2b}{a-c}$

(i)  $y + z = a [\cos^2 x + \sin^2 x] + c (\sin^2 x + \cos^2 x) = a + c$

(ii)  $y - z = a [\cos^2 x - \sin^2 x] + 4b [\sin x \cos x] + c [\sin^2 x - \cos^2 x] = [a - c] \cos 2x + b \sin(2x)$

$$\begin{aligned}
 &= (a-c) \left( \frac{1-\tan^2 x}{1+\tan^2 x} \right) + 2b \frac{2 \tan x}{1+\tan^2 x} \\
 &= (a-c) \left[ \frac{1-4b^2}{(a-c)^2} \right] + \frac{4b \cdot 2b}{1+\frac{4b^2}{(a-c)^2}} \\
 &= (a-c) \left[ \frac{(a-c)^2 - 4b^2}{(a-c)^2 + (4b^2)} \right] + \frac{8b^2(a-c)}{(a-c)^2 + 4b^2} \\
 &= \frac{1}{(a-c)^2(4b^2)} [(a-c)^3 - 4b^2(a-c) + 8b^2(a-c)] \\
 &= \frac{(a-c)[(a-c)^2 + 4b^2]}{(a-c)^2 + (4b^2)} = a-c \\
 \Rightarrow y-z &= a-c \\
 \text{Using } \cos(2x) &= \frac{1-\tan^2 x}{1+\tan^2 x} \text{ and } \sin(2x) = \frac{2 \tan x}{1+\tan^2 x}
 \end{aligned}$$

7. (a, b, d) If  $\sin \theta = \sin \alpha$

Then

- (i)  $\theta = \alpha$                       (ii)  $\theta = \pi - \alpha$
- (iii)  $\theta = -(\pi + \alpha)$             (iv)  $\theta = 2\pi + \alpha$
- (v)  $\theta = -(2\pi - \alpha)$

$$\begin{aligned}
 \therefore \sin(\theta/3) &= \sin(\alpha/3) \text{ or } \sin(\theta/3) = \sin\left(\frac{\pi}{3} - \frac{\alpha}{3}\right) \text{ or} \\
 \sin(\theta/3) &= \sin\left(\frac{\pi}{3} + \frac{\alpha}{3}\right)
 \end{aligned}$$

8. (b, c)  $x \in \left(0, \frac{\pi}{2}\right)$

$$\begin{aligned}
 \text{Given that } \frac{\sqrt{3}-1}{\sin x} + \frac{\sqrt{3}+1}{\cos x} &= 4\sqrt{2} \\
 \Rightarrow \frac{\sqrt{3}-1}{2\sqrt{2} \sin x} + \frac{\sqrt{3}+1}{2\sqrt{2} \cos x} &= 2 \\
 \Rightarrow \sin\left(\frac{\pi}{12}\right) \cos x + \cos\left(\frac{\pi}{12}\right) \sin x &= 2 \sin x \cos x \\
 \Rightarrow \sin\left(\frac{\pi}{12} + x\right) &= \sin(2x) \\
 \Rightarrow 2x &= \frac{\pi}{12} + x \text{ or } 2x = \pi - \frac{\pi}{12} - x \\
 \Rightarrow x &= \frac{\pi}{12} \text{ or } x = \frac{11\pi}{36}
 \end{aligned}$$

9. (c, d) We know that  $\sin(2nx) = {}^{2n}C_1 \cdot \cos^{2n-1}x \sin x - {}^{2n-2}C_3 \cos^{2n-3}x \sin^3x + {}^{2n-4}C_5 \cdot \cos^{2n-5}x \sin^5x \dots$

- $\therefore$  Now  $n = 1, 2$
- $\sin(2x) = {}^2C_1 \cos x \sin x$
- $\sin(4x) = {}^4C_1 \cos^3x \sin x - {}^4C_3 \cos x \sin^3x = {}^4C_1 \sin x \cos^3x - {}^4C_3 \cos x \sin^3x [1 - \cos^2x]$
- $= \sin x [4 \cos^3x + 4 \cos^3x - 4 \cos x]$
- $\therefore$  From above 2 examples we can say that  $\sin(2nx) = \sin x \cdot P_{2n-1}(\cos x)$
- $\therefore$  Each term of  $\sin x, \sin^3x, \sin^5x \dots$  can be taken separate and  $\sin^2x, \sin^4x \dots$  etc. can be converted into  $\cos^2x$
- Similarly  $\sin(2nx) = \cos x P_{2n-1}(\sin x)$

10. (a, b, c, d)  $1 - \sin 4x = \sin^2(2x) + \cos^2(2x) - 2 \sin 2x \cos 2x = [\sin(2x) - \cos(2x)]^2$   
 $\Rightarrow \sqrt{1 - \sin(4x)} = |\sin(2x) - \cos(2x)|$

Similarly  $\sqrt{1 + \sin(4x)} = |\sin(2x) + \cos(2x)|$

$$\therefore y = \frac{|\sin(2x) - \cos(2x)| + 1}{|\sin(2x) + \cos(2x)| - 1}$$

$$\begin{aligned}
 \text{(i) } y &= \frac{\sin(2x) - \cos(2x) + 1}{\sin(2x) + \cos(2x) - 1} = \frac{2 \sin x \cos x + 2 \sin^2 x}{2 \sin x \cos x - [2 \sin^2 x]} \\
 &= \frac{\cos x + \sin x}{\cos x - \sin x} = \frac{1 + \tan x}{1 - \tan x} = \tan(\pi/4 + x)
 \end{aligned}$$

$$\begin{aligned}
 \text{(ii) } y &= \frac{\cos(2x) - \sin(2x) + 1}{\sin(2x) + \cos(2x) - 1} \\
 &= \frac{2 \cos^2 x - 2 \sin x \cos x}{2 \sin x \cos x - [2 \sin^2 x]} = \cot x
 \end{aligned}$$

Similarly other options can be obtain

11. (a, b, d)

$$\begin{aligned}
 \sum_{r=1}^7 \tan^2\left(\frac{r\pi}{16}\right) &= -\tan^2\left(\frac{\pi}{16}\right) + \tan^2\left(\frac{2\pi}{16}\right) + \tan^2\left(\frac{3\pi}{16}\right) \\
 &+ 1 + \tan^2\left(\frac{5\pi}{16}\right) + \tan^2\left(\frac{6\pi}{16}\right) + \tan^2\left(\frac{7\pi}{16}\right) \\
 &= \tan^2\left(\frac{\pi}{16}\right) + \cot^2\left(\frac{\pi}{16}\right) + \tan^2\left(\frac{2\pi}{16}\right) + \cot^2\left(\frac{2\pi}{16}\right) \\
 &+ \tan^2\left(\frac{3\pi}{16}\right) + \cot^2\left(\frac{3\pi}{16}\right) + 1 = E_1 + E_2 + E_3 + 1
 \end{aligned}$$

Where  $E_1 = \tan^2(\pi/16) + \cot^2(\pi/16)$

$E_2 = \tan^2(2\pi/16) + \cot^2(2\pi/16)$  and

$E_3 = \tan^2(3\pi/16) + \cot^2(3\pi/16)$

$$\begin{aligned}
 \text{Now } S &= \tan^2\theta + \cot^2\theta = (\tan\theta + \cot\theta)^2 - 2 \\
 &= \left(\frac{\sin\theta}{\cos\theta} + \frac{\cos\theta}{\sin\theta}\right)^2 - 2 = \left(\frac{1}{\sin\theta \cos\theta}\right)^2 - 2 = \frac{4}{\sin^2(2\theta)} - 2
 \end{aligned}$$

$$\text{Now for } E_1 = \theta = \frac{\pi}{16} \Rightarrow 4\theta = \frac{\pi}{4}$$

$$\therefore S = \tan^2(\pi/16) + \cot^2(\pi/16) = \frac{4.2}{1 - \cos 4\theta} - 2$$

$$= \left(\frac{8\sqrt{2}}{\sqrt{2}-1}\right) - 2 = 16 + 8\sqrt{2} - 2 = 14 + 8\sqrt{2}$$

$$\text{For } E_2 : \theta = \frac{2\pi}{16} \Rightarrow 2\theta = \frac{\pi}{4}$$

$$\therefore S = \frac{4}{\left(\frac{1}{\sqrt{2}}\right)^2} - 2 = 6$$

$$\text{For } E_3 : \theta = \frac{3\pi}{16} \Rightarrow 4\theta = \frac{12\pi}{16} = \frac{3\pi}{4}$$

$$\therefore \cos(4\theta) = -1/\sqrt{2}$$

1.130 > Trigonometry

$$\therefore S = \frac{4.2}{1 - \cos 4\theta} - 2 = \frac{8}{1 + \frac{1}{\sqrt{2}}} - 2 = 16 - 8\sqrt{2} - 2 = 14 - 8\sqrt{2}$$

$$\therefore \text{required expression} = 14 + 8\sqrt{2} + 6 + 14 - 8\sqrt{2} + 1 = 24 + 1 = 35$$

$\therefore$  option (a)

$$\sum_{r=1}^{10} \cos^3\left(\frac{r\pi}{3}\right), \cos\left(\frac{\pi}{3}\right) = \frac{1}{2}, \cos\left(\frac{2\pi}{3}\right) = -\frac{1}{2},$$

$$\cos\left(\frac{3\pi}{3}\right) = -1, \cos\left(\frac{4\pi}{3}\right) = -\frac{1}{2}, \dots, \cos\left(\frac{6\pi}{3}\right) = 1$$

$$\sum_{r=1}^6 \cos^3\left(\frac{r\pi}{3}\right) = \theta \text{ and } \cos\left(\frac{7\pi}{3}\right) = \cos\left(2\pi + \frac{\pi}{3}\right)$$

$$\therefore \sum_{r=1}^{10} \cos^3\left(\frac{r\pi}{3}\right) = \sum_{r=7}^{10} \cos^3\left(\frac{r\pi}{3}\right) = \sum_{r=1}^4 \cos^3\left(\frac{r\pi}{3}\right) = -\frac{9}{8}$$

$\therefore$  option (b)

$$\text{We have equation whose roots are } \tan^2 \frac{\pi}{7}, \tan^2\left(\frac{3\pi}{7}\right)$$

$$\text{and } \tan^2\left(\frac{5\pi}{7}\right) \text{ is } x^6 - 21x^4 + 35x^2 - 720 \quad \dots \text{(i)}$$

$$\text{The equation whose roots are } \cot^2 \frac{\pi}{7}, \cot^2 \frac{3\pi}{7}, \cot^2 \frac{5\pi}{7}$$

$$\text{is } -7x^6 + 35x^4 - 21x^2 + 1 = 0 \quad \dots \text{(ii)}$$

$$\therefore \text{From (i) and (ii) we get } \sum_{r=1}^3 \tan^2\left(\frac{2r-1}{7}\right)\pi = 21 =$$

$$\sum_{r=1}^3 \cot^2\left(\frac{2r-1}{7}\right)\pi = -\frac{(35)}{-7} = 5$$

$$\text{But } \sum_{r=1}^3 \tan^2\left(\frac{2r-1}{7}\right)\pi \cdot \sum_{r=1}^3 \cot^2\left(\frac{2r-1}{7}\right)\pi = 21 \times 5 = 105$$

$\therefore$  option (d)

**SECTION-V (COMPREHENSION TYPE ANSWERS)**

**Passage A:**

1. (b) Let  $f(x) = x - \sin x$  “  $x \in \left(0, \frac{\pi}{2}\right)$  ”

$$f'(x) = 1 - \cos x \Rightarrow f'(x) > 0$$

$$\therefore f \text{ is an increasing function “ } x \in \left(0, \frac{\pi}{2}\right) \text{ ”}$$

$$\text{Let } 0 < \theta < \phi < \pi/2$$

$$\Rightarrow f(\theta) < f(\phi)$$

$$\Rightarrow \theta - \sin\theta < \phi - \sin\phi$$

$$\Rightarrow \theta - \phi < \sin\theta - \sin\phi$$

2. (a)  $A, B, C \in \left(-\frac{\pi}{2}, \frac{\pi}{2}\right)$ ;  $\cos A, \cos B, \cos C > 0$

$$\therefore \text{By A.M.} \quad \geq \text{G.M.}$$

$$\cos A + \cos B + \cos C \geq 3 \sqrt[3]{\cos A \cdot \cos B \cdot \cos C}$$

$$\text{Equality holds for } \cos A = \cos B = \cos C = 1/2$$

$$\Rightarrow \cos A + \cos B + \cos C \geq 3 \cdot \left(\sqrt[3]{\frac{1}{8}}\right)$$

$$\Rightarrow \cos A + \cos B + \cos C \geq \frac{3}{2}$$

$\Rightarrow$  Option (a) is true.

$$\therefore A, B, C \in \left(-\frac{\pi}{2}, \frac{\pi}{2}\right) \Rightarrow \frac{A}{2}, \frac{B}{2}, \frac{C}{2} \in \left(-\frac{\pi}{4}, \frac{\pi}{4}\right)$$

$$\text{If we take } \frac{A}{2} = \frac{B}{2} = \frac{C}{2} = 0;$$

$$\text{then } \cos \frac{A}{2} = \cos \frac{B}{2} = \cos \frac{C}{2} = 1$$

$$\Rightarrow \cos \frac{A}{2} + \cos \frac{B}{2} + \cos \frac{C}{2} + 3 \times \frac{3\sqrt{3}}{2}$$

$\Rightarrow$  Option (b) is false.

$$\text{Now, if we take } A = B = C = \frac{\pi}{3}$$

$$\Rightarrow \frac{A}{2} = \frac{B}{2} = \frac{C}{2} = \frac{\pi}{6}$$

$$\Rightarrow \sin \frac{A}{2} \sin \frac{B}{2} + \sin \frac{C}{2} = \frac{3}{2} \times \frac{1}{8}$$

$\Rightarrow$  Option (c) is false.

3. (a, b, c, d)

$$\therefore A, B, C \text{ are acute angles}$$

$$\Rightarrow \cos A, \cos B, \cos C > 0$$

$$\therefore \text{By A.M.} \geq \text{G.M., we have}$$

$$\sqrt[3]{\cos A \cdot \cos B \cdot \cos C} \leq \left(\frac{\cos A + \cos B + \cos C}{3}\right)$$

The maximum value exists for  $\cos A = \cos B = \cos C = 1/2$  i.e., when  $A = B = C = \pi/3$

$$\Rightarrow \cos A \cdot \cos B \cdot \cos C \leq \left(\frac{3}{3}\right)^3$$

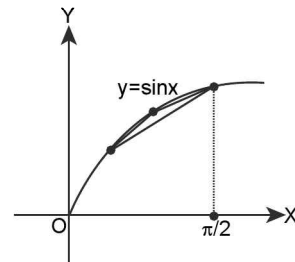

$$\Rightarrow \cos A \cdot \cos B \cdot \cos C \leq \frac{1}{8}$$

$\Rightarrow$  Option (a) is true

Now, if  $f(x) = \sin x$ ;  $x \in (0, \pi/2)$ . Let  $A, B, C \in (0, \pi/2)$  and  $A + B + C = \pi$ , then by deduction (4)

Applied at function  $y = \sin x$ ,

$$\text{We have, } \sin\left(\frac{A+B+C}{3}\right) \geq \frac{\sin A + \sin B + \sin C}{3}$$

$$\Rightarrow 3\sin(\pi/3) \geq \sin A + \sin B + \sin C$$

$$\Rightarrow \sin A + \sin B + \sin C \leq \frac{3\sqrt{3}}{2}$$

**Option (c) is true.**

Also by A.M.  $\geq$  G.M., in an acute angled triangle

$$\frac{\sin A + \sin B + \sin C}{3} \geq \sqrt[3]{\sin A \sin B \sin C}$$

$$\Rightarrow \sin A + \sin B + \sin C \geq 3\sqrt[3]{\sin A \sin B \sin C}$$

$$\Rightarrow \sin A + \sin B + \sin C \geq 3\left(\frac{\sqrt{3}}{2}\right) = \frac{3\sqrt{3}}{2} > 2$$

**Option (b) is also true**

Also by A.M.  $\geq$  G.M.,

$$\tan^2 \frac{A}{2} + \tan^2 \frac{B}{2} + \tan^2 \frac{C}{2} \geq 3\sqrt[3]{\tan^2 \frac{A}{2} \cdot \tan^2 \frac{B}{2} \cdot \tan^2 \frac{C}{2}}$$

$$\Rightarrow \tan^2 \frac{A}{2} + \tan^2 \frac{B}{2} + \tan^2 \frac{C}{2} \geq 3\left(\frac{1}{3}\right) = 1$$

**Option (d) is also true**

4. (a, c)

$$\frac{A}{2}, \frac{B}{2}, \frac{C}{2} \in \left(0, \frac{\pi}{4}\right) = \frac{\pi}{4} + \frac{A}{2}, \frac{\pi}{4} + \frac{B}{2}, \frac{\pi}{4} + \frac{C}{2} \in \left(\frac{\pi}{4}, \frac{\pi}{2}\right)$$

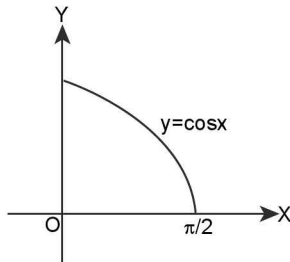

$\therefore$  By deduction (4) we get,

$$\cos\left(\frac{\sum \frac{\pi}{4} + \frac{A}{2}}{3}\right) \geq \frac{\sum \cos\left(\frac{\pi}{4} + \frac{A}{2}\right)}{3}$$

$$\Rightarrow \sum \cos\left(\frac{\pi}{4} + \frac{A}{2}\right) \leq 3\cos\left(\frac{\pi}{4} + \frac{\pi}{6}\right) = 3\left[\frac{1}{\sqrt{2}} \cdot \frac{\sqrt{3}}{2} - \frac{1}{\sqrt{2}} \cdot \frac{1}{2}\right]$$

$$= 3 \frac{(\sqrt{3}-1)}{2\sqrt{2}} < \frac{3}{2}$$

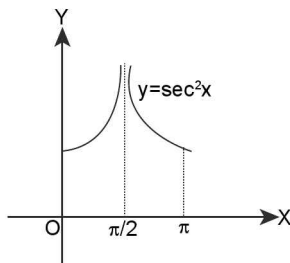

$\Rightarrow$  **Option (a) is true**  $\Rightarrow$  **Option (d) is false**

Now  $\frac{\pi}{6} + \frac{A}{4}$  etc  $\in \left(\frac{\pi}{6}, \frac{5\pi}{12}\right)$

$\therefore$  By deduction (4) we get,

$$\sec^2\left(\frac{\sum\left(\frac{\pi}{6} + \frac{A}{4}\right)}{3}\right) \leq \frac{\sum \sec^2\left(\frac{\pi}{6} + \frac{A}{4}\right)}{3}$$

$$\Rightarrow \sum \sec^2\left(\frac{\pi}{6} + \frac{A}{4}\right) \geq 3\sec^2\left(\frac{\pi}{6} + \frac{\pi}{12}\right) = 6$$

$$\therefore \sum \sec^2\left(\frac{\pi}{6} + \frac{\pi}{4}\right) \geq 6 > 3$$

$\Rightarrow$  **Option (b) is false and Option (c) is true.**

**Passage B:**

5. (a), 6. (b) 7. (d)

$$\therefore \cos A \cos B \cos C = \frac{\sqrt{3}-1}{8}$$

$$\sin A \sin B \sin C = \frac{3+\sqrt{3}}{8}$$

$$\therefore \tan A \tan B \tan C = \frac{3+\sqrt{3}}{\sqrt{3}-1} \quad \dots (1)$$

$$\begin{aligned} \text{Now } \tan A + \tan B + \tan C &= \tan A \tan B \tan C \\ &= \frac{3+\sqrt{3}}{\sqrt{3}-1} \quad \dots (2) \end{aligned}$$

$$\text{Now } A + B + C = \pi$$

$$\cos(A + B + C) = -1$$

$$\cos A \cos B \cos C [1 - \sum \tan A \tan B] = -1$$

$$\frac{\sqrt{3}-1}{8} [1 - \sum \tan A \tan B] = -1$$

$$\Rightarrow \sum \tan A \tan B = 5 + 4\sqrt{3} \quad \dots (3)$$

from (1), (2) & (3)

$\tan A, \tan B, \tan C$  are roots of

$$x^3 - \left(\frac{3+\sqrt{3}}{\sqrt{3}-1}\right)x^2 + (5+4\sqrt{3})x - \frac{(3+\sqrt{3})}{\sqrt{3}-1} = 0$$

$$x^3 - (2+\sqrt{3})\sqrt{3}x^2 + (5+4\sqrt{3})x - (2+\sqrt{3})\sqrt{3} = 0$$

$$x^3 - (3+2\sqrt{3})x^2 + (5+4\sqrt{3})x - (3+2\sqrt{3}) = 0$$

$$(x-1)(x-\sqrt{3})(x-(2+\sqrt{3})) = 0$$

$$\therefore \tan A = 1, \tan B = \sqrt{3}, \tan C = 2 + \sqrt{3}$$

**Passage C:**

8. (a)  $\cot^2 \theta = \frac{1}{2} [6 + (\cot A - \cot B)^2 + (\cot B - \cot C)^2 + (\cot C - \cot A)^2]$

$$\therefore \cot^2 \theta \geq 3 \Rightarrow \theta \leq 30^\circ$$

1.132 > Trigonometry

$$9. (d) \frac{\sin A \sin B \sin C}{1 + \cos A \cos B \cos C} = \frac{\tan A \tan B \tan C}{\sec A \sec B \sec C + 1}$$

$$= \frac{\tan A \tan B \tan C}{\Sigma \tan B \tan C} = \frac{1}{\Sigma \cot A} = \tan \theta.$$

$$10. (c) \cot B + \cot C = \cot \theta - \cot A$$

$$\Rightarrow \frac{\sin(A - \theta)}{\sin \theta} = \frac{\sin^2 A}{\sin B \sin C}$$

$$\Pi(\sin A - \theta) = \sin^3 \theta.$$

Passage D:

$$11. (c) \text{ In any triangle } \cos(A + B + C) = -1$$

$$\Rightarrow \cos A \cos(B + C) - \sin A \sin(B + C) = -1$$

$$\Rightarrow \cos A \cos B \cos C - \cos A \sin B \sin C - \sin A \sin B \cos C - \sin A \cos B \sin C = -1$$

Now divide by  $\cos A \cos B \cos C$  to get the choice (c).

$$12. (c) \text{ Divide the identity of above question by } \tan A \tan B \tan C.$$

$$13. (c) \text{ Convert to sine and cosine}$$

$$14. (b) \text{ Applying sine rule in } \triangle OAB, \text{ we get}$$

$$\frac{OB}{\sin \omega} = \frac{AB}{\sin(180^\circ - B)}$$

or  $OB = \frac{c \sin \omega}{\sin B}$  ... (i)

Again applying sine rule in  $\triangle OBC$ , we get

$$\frac{OB}{\sin(C - \omega)} = \frac{BC}{\sin(180^\circ - C)}$$

or  $OB = \frac{a \sin(C - \omega)}{\sin B}$  ... (ii)

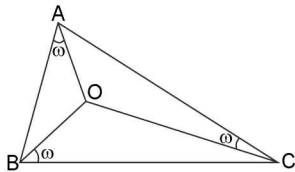

Equating the value of OB in (i) and (ii), we get

$$\frac{c \sin \omega}{\sin B} = \frac{a \sin(C - \omega)}{\sin C}$$

$$\Rightarrow \frac{\sin C \sin \omega}{\sin B} = \frac{\sin A}{\sin C} \quad (\sin C \cos \omega - \cos C \sin \omega)$$

$$\Rightarrow \frac{\sin C}{\sin B} = \sin A (\cot \omega - \cot C)$$

$$\Rightarrow \cot \omega - \cot C = \frac{\sin C}{\sin A \sin B} = \frac{\sin(A + B)}{\sin A \sin B}$$

$$\Rightarrow \cot \omega - \cot C = \cot A + \cot B$$

$$\Rightarrow \cot \omega = \cot A + \cot B + \cot C$$

Now, (ii) follows by squaring (i) and using the fact  $\cot A \cot B + \cot B \cot C + \cot C \cot A = 1$ .

Passage E:

$$15. (c) \sin \frac{9\pi}{14} \sin \frac{11\pi}{14} \sin \frac{13\pi}{14}$$

$$= \sin \frac{\pi}{14} \sin \frac{3\pi}{14} \sin \frac{5\pi}{14}$$

$$= \cos \frac{3\pi}{7} \cos \frac{2\pi}{7} \cos \frac{\pi}{7}$$

$$= -\cos \frac{\pi}{7} \cos \frac{2\pi}{7} \cos \frac{4\pi}{7}$$

$$= \frac{-\sin 8\pi/7}{8 \sin \pi/7} = \frac{1}{8}$$

$$16. (b) \cos 2^3 \frac{\pi}{10} \cdot \cos 2^4 \frac{\pi}{10} \dots \cos 2^{10} \frac{\pi}{10}$$

$$= \frac{\sin 2^{11} \frac{\pi}{10}}{256 \sin 2^3 \frac{\pi}{10}} = \frac{1}{256}$$

$$17. (c) \cos \frac{\pi}{11} \cdot \cos \frac{2\pi}{11} \dots \cos \frac{11\pi}{11}$$

$$= \left( \cos \frac{\pi}{11} \cos \frac{2\pi}{11} \cos \frac{3\pi}{11} \cos \frac{4\pi}{11} \cos \frac{5\pi}{11} \right)^2$$

$$= \left( \cos \frac{\pi}{11} \cos \frac{2\pi}{11} \cos \frac{4\pi}{11} \cos \frac{8\pi}{11} \cos \frac{5\pi}{11} \right)^2$$

$$= \left( \frac{\sin \frac{16\pi}{11} \cos \frac{5\pi}{11}}{16 \sin \frac{\pi}{11}} \right)^2 = \left( \frac{2 \sin \frac{5\pi}{11} \cos \frac{5\pi}{11}}{32 \sin \frac{\pi}{11}} \right)^2 = \frac{1}{1024}$$

Passage F:

$$18. (a) \quad 19. (c) \quad 20. (c)$$

$$(2 \sin x - \cos x)(1 + \cos x) = \sin^2 x$$

$$\Rightarrow (1 + \cos x)[2 \sin x - \cos x - 1 + \cos x] = 0$$

$$\Rightarrow (1 + \cos x)(2 \sin x - 1) = 0$$

$$\Rightarrow \cos x = -1 \text{ or } \sin x = 1/2$$

so  $\sin \alpha = 1/2$  [as  $0 \leq \alpha \leq \pi/2$ ]

$$\Rightarrow \cos \alpha = \sqrt{3}/2 \quad \dots(1)$$

Next,  $3 \cos^2 x - 10 \cos x + 3 = 0$

$$\Rightarrow (3 \cos x - 1)(\cos x - 3) = 0$$

$$\Rightarrow \cos x = 1/3 \text{ as } \cos x \neq 3$$

So  $\cos \beta = 1/3, \sin \beta = \frac{2\sqrt{2}}{3} \quad \dots(2)$

and  $1 - \sin 2x = \cos x - \sin x$

$$\sin^2 x + \cos^2 x - 2 \sin x \cos x = \cos x - \sin x$$

$$(\cos x - \sin x)(\cos x - \sin x - 1) = 0$$

$$\Rightarrow \text{Either } \sin x = \cos x \Rightarrow \sin \gamma = \cos \gamma = 1/\sqrt{2} \quad \dots(3)$$

or  $\cos x - \sin x = 1 \Rightarrow \cos x = 1, \sin x = 0$

$$\Rightarrow \cos \gamma = 1, \sin \gamma = 0 \quad (4)$$

So that  $\cos \alpha + \cos \beta + \cos \gamma$  can be equal to

$$\frac{\sqrt{3}}{2} + \frac{1}{3} + \frac{1}{\sqrt{2}} \text{ or } \frac{\sqrt{3}}{2} + \frac{1}{3} + 1$$

i.e.  $\frac{3\sqrt{6} + 2\sqrt{2} + 6}{6\sqrt{2}} \text{ or } \frac{3\sqrt{3} + 8}{6}$

$\sin \alpha + \sin \beta + \sin \gamma$  can be equal to

$$\frac{1}{2} + \frac{2\sqrt{2}}{3} + \frac{1}{\sqrt{2}} \text{ or } \frac{1}{2} + \frac{2\sqrt{2}}{3} + 0$$

$$\text{i.e., } \frac{3\sqrt{2}+14}{6\sqrt{2}} \text{ or } \frac{3+4\sqrt{2}}{6}$$

and  $\sin(\alpha - \beta)$  is equal to  
 $\sin \alpha \cos \beta - \cos \alpha \sin \beta$

$$= \frac{1}{2} \times \frac{1}{3} - \frac{\sqrt{3}}{2} \times \frac{2\sqrt{2}}{3} = \frac{1-2\sqrt{6}}{6}$$

**SECTION - VI (MATCH THE COLUMN TYPE ANSWERS)**

1. (i) → (b, c); (ii) → (a, b, c, d); (iii) → (c); (iv) → (a, b)

(i)  $E = \cos^2(A - B) + \cos^2 B - 2 \cos(A - B) \cos A \cos B$   
 $= \cos(A - B) [\cos(A - B) - 2 \cos A \cos B] + \cos^2 B = -$   
 $\cos(A - B) [\cos(A + B)] + \cos^2 B$   
 $= \sin^2 A - \cos^2 B + \cos^2 B = \sin^2 A$

∴ E is independent of B and C

(ii)  $a = \cos A \cos B + \sin A \sin B \cos C$   
 $b = \cos A \sin B - \sin A \cos B \cos C$   
 $c = \sin A \sin C$

$$a^2 + b^2 = \cos^2 A \cos^2 B + \sin^2 A \sin^2 B \cos^2 C + \cos^2 A \sin^2 B + \sin^2 A \cos^2 B \cos^2 C$$

$$= \cos^2 A [\cos^2 B + \sin^2 B] + \sin^2 A \cos^2 C [\sin^2 B + \cos^2 B] = \cos^2 A + \sin^2 A \cos^2 C$$

∴  $a^2 + b^2 + c^2 = \cos^2 A + \sin^2 [\cos^2 C + \sin^2 C] = 1$  constant

(iii)  $x^2 + Ax + B = 0$

Given  $\tan a + \tan b = -A$   
 $\tan a \tan b = B$

Now  $\tan(a + b) = \frac{\tan a + \tan b}{1 - \tan a \tan b} = \frac{-A}{1 - B} = \frac{A}{B - 1}$

∴  $\sin(a + b) = \frac{B - 1}{\sqrt{A^2 + (B - 1)^2}}$

∴  $\sin(a + b)$  is independent of C.

(iv)  $\frac{\tan(A + B - C)}{\tan(A + C - B)} = \frac{\tan C}{\tan B} = \frac{\tan(\pi - 2C)}{\tan(\pi - 2B)} = \frac{\tan C}{\tan B}$   
 $= \frac{\tan 2C}{\tan 2B} = \frac{\tan C}{\tan B} = \frac{2 \tan C / 1 - \tan^2 C}{2 \tan B / 1 - \tan^2 B} = \frac{\tan C}{\tan B}$   
 $= \frac{\tan C}{\tan B} \left[ \frac{\tan^2 C - \tan^2 B}{1 - \tan^2 C} \right] = 0$

⇒  $\tan C = 0$  or  $\tan C = \pm \tan B$

⇒  $C = n\pi$ ;  $n \in \mathbb{Z}$  or  $C = n\pi \pm B$

⇒  $C \mp B = n\pi$  but  $B \pm C \neq n\pi$ .

⇒  $C = n\pi$ .

∴  $\sin C + \cos C + \tan C = 0 + (-1)^n + 0 = (-1)^n$  which is independent of A and B.

2. (i) → (b); (ii) → (d); (iii) → (b); (iv) → (a, b, c)

(i)  $x \sin^2 a + y \cos^2 a = \sin a \cos a$  ..... (i)  
 $x \sin a = y \cos a$

$y = x \tan a$

Put  $y = x \tan a$  in equation (i)

⇒  $x \sin^2 a + \cos^2 a \cdot \frac{x \sin a}{\cos a} = \sin a \cos a$

⇒  $x \sin^2 a + x \sin a \cos^2 a = \sin a \cos a$

⇒  $x \sin^2 a + x \cos^2 a = \cos a$

⇒  $x = \cos a$

⇒  $y = \sin a$

⇒  $x^2 + y^2 = 1$

(ii)  $x = \sin \theta = y \sin\left(\theta + \frac{2\pi}{3}\right) = z \sin\left(\theta + \frac{4\pi}{3}\right) = k$

⇒  $\frac{1}{x} = \frac{\sin \theta}{k}, \frac{1}{y} = \frac{\sin\left(\theta + \frac{2\pi}{3}\right)}{k}, \frac{1}{z} = \frac{\sin\left(\theta + \frac{4\pi}{3}\right)}{k}$

⇒  $\frac{1}{x} + \frac{1}{y} + \frac{1}{z} = \frac{1}{k} \left[ \sin \theta + \sin\left(\theta + \frac{2\pi}{3}\right) + \sin\left(\theta + \frac{4\pi}{3}\right) \right] = 0$

⇒  $yz + xz + xy = 0 \Rightarrow \Sigma xy = 0$

⇒  $4 + \Sigma xy = 4$

(iii)  $A = \sin^8 \theta + \cos^{14} \theta = (\sin^2 \theta)^4 + (\cos^2 \theta)^7 \leq \sin^2 \theta + \cos^2 \theta \leq 1$

(iv) Given  $\sin x + \sin y = 3(\cos y - \cos x)$

⇒  $2 \sin\left(\frac{x+y}{2}\right) \cos\left(\frac{x-y}{2}\right) = 3 \left[ 2 \sin\left(\frac{y+x}{2}\right) \sin\left(\frac{x-y}{2}\right) \right]$  ..... (i)

Now  $\sin 3x + \sin 3y = 2 \sin\left(\frac{3x+3y}{2}\right) \cos\left(\frac{3x-3y}{2}\right)$

$= 2 \sin 3 \left( \frac{x+y}{2} \right) \cos 3 \left( \frac{x-y}{2} \right) ; \frac{x+y}{2} = \theta ; \frac{x-y}{2} = \phi (\text{say})$   
 $= 2 [\sin 3\theta \cos 3\phi]$  ..... (ii)

From (i), we get,

$2 \sin\left(\frac{x+y}{2}\right) \left[ \cos\left(\frac{x-y}{2}\right) - 3 \sin\left(\frac{x-y}{2}\right) \right] = 0$

Either  $\sin\left(\frac{x+y}{2}\right) = 0$  or  $\tan\left(\frac{x-y}{2}\right) = \frac{1}{3}$

⇒  $\sin \theta = 0$  or  $\tan \phi = 1/3 \left( \cos \phi = \pm \frac{3}{\sqrt{10}} \right)$

∴ If  $\sin \theta = 0$ , then from (ii), required expression = 0

If  $\tan \phi = 1/3$  then equation (i) is true for all values of  $\sin\left(\frac{x+y}{2}\right)$  and hence for infinitely many pairs (x, y)

for which  $\tan\left(\frac{x-y}{2}\right) = \frac{1}{3}$  i.e., the given expression

i.e.,  $\sin 3x + \sin 3y$  will not have a constant value.

∴ Also for  $\cos \phi = \pm 3/\sqrt{10}$ ;  $\cos 3\phi = 4 \left( \pm \frac{3}{\sqrt{10}} \right)^3 - 3 \left( \pm \frac{3}{\sqrt{10}} \right)$

$= \pm \frac{108}{10\sqrt{10}} \mp \frac{9}{\sqrt{10}} = \frac{1}{\sqrt{10}} \left( \pm \frac{108}{10} \mp 9 \right)$

1.134 > Trigonometry

$$= \frac{1}{\sqrt{10}} \left( \frac{108}{10} - 9 \right) \text{ or } \frac{1}{\sqrt{10}} \left( \frac{-108}{10} + 9 \right) = \pm \frac{18}{10\sqrt{10}}$$

$$\therefore \sin 3x + \sin 3y = 2 \sin 3\theta \left( \pm \frac{9}{5\sqrt{10}} \right) = \pm \frac{18}{5\sqrt{10}} \sin 3\theta = 1$$

If  $\sin 3\theta = \frac{5\sqrt{10}}{18}$  which is possible for a pair (x, y) such

$$\text{that } \tan \left( \frac{x-y}{3} \right) = \frac{1}{3}$$

3. (i) → (d); (ii) → (b); (iii) → (a); (iv) → (c)

(i)  $(a+2) \sin a + (2a-1) \cos a = 2a+1$

The equation  $a \sin x + b \cos x = c$  is solvable if  $|c| \leq \sqrt{a^2 + b^2}$

∴ Here  $(2a+1)^2 \leq (2a-1)^2 + (a+2)^2$  is always true

$$\text{Now } \sin a = \frac{2 \tan(a/2)}{1 + \tan^2(a/2)}, \cos a = \frac{1 - \tan^2(a/2)}{1 + \tan^2(a/2)}$$

Let  $\tan(a/2) = t$

∴ given equation becomes

$$(a+2) \cdot \frac{2t}{1+t^2} + (2a-1) \left( \frac{1-t^2}{1+t^2} \right) = 2a+1$$

$$\begin{aligned} \Rightarrow (a+2) \cdot 2t + (2a-1)(1-t^2) &= (2a+1)(1+t^2) \\ \Rightarrow 2(a+2)t + 2a - 2at^2 - 1 + t^2 &= 2a + 2at^2 + 1 + t^2 \\ \Rightarrow 4at^2 - 2(a+2)t + 2 &= 0 \\ \Rightarrow 2at^2 - (a+2)t + 1 &= 0 \\ \Rightarrow 2at^2 - at - 2t + 1 &= 0 \\ \Rightarrow at[2t-1] - 1[2t-1] &= 0 \end{aligned}$$

$$\Rightarrow t = 1/2, t = 1/a; \text{ given } \tan \frac{a}{2} \neq \frac{1}{a}$$

$$\Rightarrow t = 1/2$$

$$\Rightarrow \tan a = \frac{2 \tan(a/2)}{1 - \tan^2(a/2)} = \frac{1}{1 - \frac{1}{4}} = \frac{4}{3}$$

(ii)  $\operatorname{cosec} \theta = 3 + \frac{1}{12} = \frac{37}{12}$

$$\cot^2 \theta = \operatorname{cosec}^2 \theta - 1 = \left( \frac{37}{12} \right)^2 - 1 = \frac{(37)^2 - (12)^2}{(12)^2} = \frac{25 \times 49}{12 \times 12}$$

$$\therefore \cot \theta = \frac{35}{12}$$

$$\therefore \frac{\operatorname{cosec} \theta + \cos \theta}{8} = \frac{\frac{37}{12} \pm \frac{35}{12}}{8} = \frac{6}{8} \text{ or } \frac{1}{48}$$

$$\therefore \frac{3}{4}$$

(iii)  $\sin^2 \left( \frac{8\pi}{18} \right) = \sin^2 \left( \frac{\pi}{2} - \frac{\pi}{18} \right) = \cos^2 \left( \frac{\pi}{18} \right)$

$$\therefore \sin^2 \left( \frac{4\pi}{9} \right) = \cos^2 \left( \frac{\pi}{18} \right)$$

$$\text{and } \sin^2 \left( \frac{7\pi}{18} \right) = \sin^2 \left( \frac{\pi}{2} - \frac{\pi}{9} \right) = \cos^2 \left( \frac{\pi}{9} \right)$$

∴ given expression

$$\begin{aligned} &\sin^2 \left( \frac{\pi}{18} \right) + \sin^2 \left( \frac{\pi}{9} \right) + \sin^2 \left( \frac{7\pi}{18} \right) + \sin^2 \left( \frac{4\pi}{9} \right) \\ &= \sin^2 \left( \frac{\pi}{18} \right) + \sin^2 \left( \frac{\pi}{9} \right) + \cos^2 \left( \frac{\pi}{18} \right) + \cos^2 \left( \frac{\pi}{9} \right) = 2 \end{aligned}$$

(iv)  $\theta = \frac{\pi}{4n}$

$$\therefore n\theta = \frac{\pi}{4}$$

∴ Each term of the given expression is 1

∴ Required product = 1

4. (i) → (d); (ii) → (c); (iii) → (b); (iv) → (a)

(i)  $E = \cos(2\alpha + \theta) + \cos(2\beta + \theta) = \cos(2\alpha) \cos \theta - \sin(2\alpha) \sin \theta + \cos(2\beta) \cos \theta - \sin(2\beta) \sin \theta$   
 $= [\cos 2\alpha + \cos(2\beta)] \cos \theta - \sin \theta [\sin(2\alpha) + \sin(2\beta)]$

∴ Maximum value of E is

$$\begin{aligned} &\sqrt{[\cos(2\alpha) + \cos(2\beta)]^2 + [\sin(2\alpha) + \sin(2\beta)]^2} \\ &= \sqrt{1 + 1 + 2[\cos(2\alpha)\cos(2\beta) + \sin(2\alpha)\sin(2\beta)]} \\ &= \sqrt{2 + 2\cos(2(\alpha - \beta))} \\ &= \sqrt{2 \times [1 + \cos(2(\alpha - \beta))]} \\ &= 2 \cos(\alpha - \beta) \end{aligned}$$

(ii)  $E = \cos(2\alpha) + \cos(2\beta) = 2 \cos(\alpha + \beta) \cos(\alpha - \beta)$

Since maximum value of  $\cos(\alpha - \beta)$  is 1

∴ Maximum value of given expression is  $2 \cos(\alpha + \beta)$

(iii)  $\forall \alpha, \beta \in \left( 0, \frac{\pi}{4} \right)$

$\sec 2\alpha$  and  $\sec 2\beta$  are both positive. Now, applying AM ≥ HM

$$\frac{\cos 2\alpha + \cos 2\beta}{2} \geq \frac{2}{\sec 2\alpha + \sec 2\beta}$$

$$\Rightarrow \sec 2\alpha + \sec 2\beta \geq \frac{4}{\cos 2\alpha + \cos 2\beta}$$

$$\Rightarrow \sec 2\alpha + \sec 2\beta \geq \frac{2}{\cos(\alpha + \beta) + \cos(\alpha - \beta)}$$

$$\Rightarrow \sec 2\alpha + \sec 2\beta \geq \frac{2 \sec(\alpha + \beta)}{\cos(\alpha - \beta)}$$

$$\Rightarrow \sec 2\alpha + \sec 2\beta \geq \left( \frac{2 \sec(\alpha + \beta)}{\cos(\alpha - \beta)} \right)_{\min} = 2 \sec(\alpha + \beta)$$

$$\Rightarrow (\sec 2\alpha + \sec 2\beta)_{\min} = 2 \sec(\alpha + \beta)$$

(iv)  $E = \sqrt{\tan \theta + \cot \theta - 2 \cos(2(\alpha + \beta))}$

$$\tan \theta + \cot \theta \geq 2$$

$$\Rightarrow \tan \theta + \cot \theta - 2 \cos(2(\alpha + \beta)) \geq 2 - 2 \cos(2(\alpha + \beta)) \geq 2 \cdot 2 \sin^2(\alpha + \beta)$$

Minimum value of given expression is  $2 \sin(\alpha + \beta)$ .

**SECTION – VII (ASSERTION AND REASON TYPE ANSWERS)**

1. (a) Using A.M  $\geq$  GM.

$$\frac{\tan A + \tan B + \tan C}{3} \geq (\tan A \tan B \tan C)^{1/3}$$

Also in a  $\Delta$ ;  $\tan A + \tan B + \tan C = \tan A \cdot \tan B \cdot \tan C$

$$\Rightarrow \frac{\tan A \cdot \tan B \cdot \tan C}{3} \geq (\tan A \tan B \tan C)^{1/3}$$

Let  $t = \tan A \tan B \tan C$

$$\Rightarrow t \geq 3(t)^{1/3}$$

Cubing both sides we get,  $t^3 \geq 27t$

$$\Rightarrow t[t^2 - 27] \geq 0 \quad \Rightarrow t(t - 3\sqrt{3})(t + 3\sqrt{3}) \geq 0$$

$$\therefore t \geq 3\sqrt{3}$$

$\therefore$  Minimum value of  $\Pi \tan A$  is  $3\sqrt{3}$

$\Rightarrow$  Assertion is true and reason is correct explanation of assertion

2. (d)  $a^2 + b^2 + c^2 - ab - bc - ca$

$$= \frac{1}{2} [2a^2 + 2b^2 + 2c^2 - 2ab - 2bc - 2ca]$$

$$= \frac{1}{2} [(a-b)^2 + (b-c)^2 + (c-a)^2] > 0$$

$$\therefore a^2 + b^2 + c^2 > [ab + bc + ca]$$

$$\Rightarrow 0 < \frac{ab + bc + ca}{a^2 + b^2 + c^2} < 1$$

$\therefore$  Assertion is wrong reason is correct

3. (a)  $\cos \alpha + \cos \left( \alpha + \frac{2\pi}{3} \right) + \cos \left( \alpha + \frac{4\pi}{3} \right)$

$$= \cos \alpha + \cos \left( \pi - \frac{\pi}{3} + \alpha \right) + \cos \left( \pi + \frac{\pi}{3} + \alpha \right)$$

$$= \cos \alpha + \cos \left( \pi - \left( \frac{\pi}{3} - \alpha \right) \right) + \cos \left( \pi + \left( \frac{\pi}{3} + \alpha \right) \right)$$

$$= \cos \alpha - \cos \left( \frac{\pi}{3} - \alpha \right) - \cos \left( \frac{\pi}{3} + \alpha \right)$$

$$= \cos \alpha - \left[ \cos \left( \frac{\pi}{3} - \alpha \right) + \cos \left( \frac{\pi}{3} + \alpha \right) \right]$$

$$= \cos \alpha - 2 \cos \left( \frac{R}{3} \right) \cos \alpha = 0$$

$$\therefore \cos^3 \alpha \cos^2 \left( \alpha + \frac{2\pi}{3} \right) + \cos^3 \left( \alpha + \frac{4\pi}{3} \right)$$

$$= 3 \cos \alpha \cos \left( \alpha + \frac{2\pi}{3} \right) \cos \left( \alpha + \frac{4\pi}{3} \right)$$

4. (a) In second quadrant  $\sin x$  is a decreasing function.

$$\therefore 2 < 3 \quad \Rightarrow \sin 2 > \sin 3$$

5. (a)  $\cos(\beta - \gamma) + \cos(\gamma - \alpha) + \cos(\alpha - \beta) = -\frac{3}{2}$

$$\Rightarrow 2 \cos(\beta - \gamma) + 2 \cos(\gamma - \alpha) + 2 \cos(\alpha - \beta) + 1 + 1 + 1 = 0$$

$$\Rightarrow \sin^2 \alpha + \cos^2 \alpha + 2 \cos \beta \cos \gamma + 2 \sin \beta \sin \gamma + \sin^2 \beta + \cos^2 \beta + 2 \cos \gamma \cos \alpha + 2 \sin \alpha \sin \gamma + \sin^2 \gamma + \cos^2 \gamma + 2 \cos \alpha + \cos \beta + 2 \sin \alpha \sin \beta = 0$$

$$\Rightarrow (\cos \alpha + \cos \beta + \cos \gamma)^2 + (\sin \alpha + \sin \beta + \sin \gamma)^2 = 0$$

$$\Rightarrow \cos \alpha + \cos \beta + \cos \gamma = 0 \text{ and } \sin \alpha + \sin \beta + \sin \gamma = 0$$

Hence assertion is true but reason is not correct explanation

Since  $\alpha^2 + \beta^2 = 0$

If  $\alpha, \beta \in \mathbb{R}$  then  $\alpha = \beta = 0$  is only possibility

6. (a) **R:**  $\tan \beta = \tan [\alpha - \alpha + r\beta - (r-1)\beta] = \tan [(\alpha + r\beta) - \tan$

$$[\alpha + (r-1)\beta] = \frac{\tan(\alpha + r\beta) - \tan(\alpha + (r-1)\beta)}{1 + \tan(\alpha + r\beta) \tan(\alpha + (r-1)\beta)}$$

$$\left[ \because \tan(A - B) = \frac{\tan A - \tan B}{1 + \tan A \tan B} \right]$$

Hence reason is correct.

**A:** From reason

$$\tan \beta [1 + \tan(\alpha + r\beta) \tan(\alpha + (r-1)\beta)]$$

$$= \tan(\alpha + r\beta) - \tan(\alpha + (r-1)\beta)$$

$$\Rightarrow \tan(\alpha + r\beta) \tan(\alpha + (r-1)\beta)$$

$$= \frac{\tan(\alpha + r\beta) - \tan(\alpha + (r-1)\beta)}{\tan \beta} - 1$$

$$\therefore \text{Required sum} = \sum_{r=1}^n \tan(\alpha + r\beta) \tan(\alpha + (r-1)\beta)$$

$$= \frac{1}{\tan \beta} \cdot \sum_{r=1}^n \tan(\alpha + r\beta) - \tan(\alpha + (r-1)\beta) - \sum_{r=1}^n 1$$

$$= \frac{1}{\tan \beta} \left[ \tan(\alpha + \beta) - \tan \alpha + \tan(\alpha + 2\beta) - \tan(\alpha + \beta) + \tan(\alpha + 3\beta) - \tan(\alpha + 2\beta) \right. \\ \left. \dots \tan(\alpha + n\beta) - \tan(\alpha + (n-1)\beta) \right] - n$$

$$= \frac{\tan(\alpha + n\beta) - \tan \alpha}{\tan \beta} - n = \frac{\tan(\alpha + n\beta) \tan \alpha - n \tan \beta}{\tan \beta}$$

7. (a) **A:**  $\sqrt{17 \sec^2 x + 16 \left[ \frac{1}{2} \tan x \sec x - 1 \right]} = 2 \tan x [1 + 4 \sin x]$

$$\Rightarrow \sqrt{\frac{17}{\cos^2 x} + 8 \cdot \frac{\sin x}{\cos^2 x} - 16} = \frac{2 \sin x}{\cos x} [1 + 4 \sin x]$$

$$\Rightarrow \sqrt{\frac{17 + 8 \sin x - 16 \cos^2 x}{\cos^2 x}} = \frac{2 \sin x}{\cos x} [1 + 4 \sin x]$$

$$\Rightarrow \frac{1}{\cos x} \sqrt{17 + 8 \sin x - 16(1 - \sin^2 x)} = 2 \frac{\sin x}{\cos x} (1 + 4 \sin x)$$

$$\Rightarrow \sqrt{(4 \sin x + 1)^2} = 2 \sin x (1 + 4 \sin x)$$

$$\Rightarrow |4 \sin x + 1| = 2 \sin x (4 \sin x + 1) \text{ for } x \in [0, \pi] \sin x > 0$$

$$\therefore 4 \sin x + 1 = 2 \sin x (4 \sin x + 1)$$

$$\Rightarrow \sin x = \frac{1}{2}$$

Hence two solutions possible. Also  $|x| = x$  “ $x \in \mathbb{R}^+$  is true by definition. Hence assertion is true and reason is the correct explanation of Assertion.



1.136 > Trigonometry

8. (c) Reason is wrong: because  $\tan (A_1 + A_2 + \dots + A_n) = \frac{s_1 - s_3 + s_5 - s_7}{1 - s_2 + s_4, \dots}$

$$\Rightarrow \tan(A+B+C) = \frac{\tan A + \tan B + \tan C - \tan A \tan B \tan C}{1 - \tan A \tan B - \tan B \tan C - \tan C \tan A}$$

A: If  $x + y + z = \pi$  then  $\tan (x + y + z) = 0$

$$\Rightarrow \tan x + \tan y + \tan z = \tan x \tan y \tan z$$

Given  $\frac{\tan x}{1} = \frac{\tan y}{2} = \frac{\tan z}{3} = k$

$$\Rightarrow \tan x = k, \tan y = 2k, \tan z = 3k$$

$$\Rightarrow k + 2k + 3k = 6k^3$$

$$\Rightarrow 6k^3 - 6k = 0 \Rightarrow 6k[k^2 - 1] = 0$$

$$\Rightarrow k = 0, +1, -1$$

But  $k \neq 0$

$\therefore$  Only 2 solutions. Hence assertion is correct.

9. (a) A: Since  $x, y \in \left[0, \frac{\pi}{2}\right]$

Therefore all  $\tan^4 x, \tan^4 y, \cot^2 x, \cot^2 y$  are positive.

$\therefore$  Using A.M  $\geq$  G.M for the numbers  $\tan^4 x, \tan^4 y,$

$$\frac{1}{\tan^2 x \cdot \tan^2 y} + \frac{1}{\tan^2 x \cdot \tan^2 y}$$

$$\text{We get } \frac{\tan^4 x + \tan^4 y + \frac{1}{\tan^2 x \cdot \tan^2 y} + \frac{1}{\tan^2 x \cdot \tan^2 y}}{4}$$

$$\geq 4 \sqrt{\tan^4 x \cdot \tan^4 y \cdot \frac{1}{\tan^2 x \cdot \tan^2 y} \cdot \frac{1}{\tan^2 x \cdot \tan^2 y}} \geq 4$$

$$\therefore \tan^4 x + \tan^4 y + 2 \cot^2 x \cot^2 y \geq 4$$

$$\therefore \text{LHS} \geq 4$$

$$\text{Also } 0 \leq \sin^2(x + y) \leq 1$$

$$\Rightarrow 3 \leq 3 + \sin^2(x + y) \leq 4$$

$$\therefore \text{RHS} \leq [3, 4]$$

$\therefore$  Only equality holds i.e.,  $\sin^2(x + y) = +1$

$$\Rightarrow x + y = \frac{\pi}{2}$$

$$\therefore \tan^4 x + \tan^4 y + 2 \cos^2 x \cos^2 y$$

$$= \tan^4 x + \tan^4 \left(\frac{\pi}{2} - x\right) + 2 \cot^2 x \cot^2 \left(\frac{\pi}{2} - x\right)$$

$$= \tan^4 x + \cot^4 x + 2 = (\tan^2 x + \cot^2 x)^2$$

$$\Rightarrow \tan^2 x + \cot^2 x = 2 \Rightarrow \tan x = 1$$

$$\Rightarrow x = \pi/4 \text{ and } y = \pi/4$$

$\therefore$  Only one solution. Also reason is correct by deification and reason is correct explanation of assertion.

10. (a)  $f(x) = \frac{x^4 - 3x^2 + 3}{x^4 - x^2 + 1} \Rightarrow y = \frac{x^4 - 3x^2 + 3}{x^4 - x^2 + 1}$

$$\Rightarrow x^4 y - x^2 y + y = x^4 - 3x^2 + 3$$

$$\Rightarrow (y - 1)x^4 + x^2 [3 - y] + (y - 3) = 0. \text{ Which is a quadratic in } x^2.$$

Let  $x^2 = t$

$$\therefore (y - 1)t^2 + (3 - y)t + (y - 3) = 0 \dots\dots(i)$$

$$D \geq 0$$

$$\Rightarrow 9 + y^2 - 6y - 4(y - 1)(y - 3) \geq 0$$

$$\Rightarrow y^2 - 6y + 9 - 4y^2 + 16y - 12 \geq 0$$

$$\Rightarrow 3y^2 - 10y + 3 \leq 0 \Rightarrow 3y^2 - 9y - y + 3 \leq 0$$

$$\Rightarrow 3y[y - 3] - [y - 3] \leq 0$$

$$\Rightarrow \left(y - \frac{1}{3}\right)(y - 3) \leq 0$$

$$\Rightarrow y \in \left[\frac{1}{3}, 3\right] \dots\dots(ii)$$

Also we have supposed  $x^2 = t$  and  $x \in \mathbb{R}$

$\Rightarrow$  both roots of quadratic (i) must be positive.

$$\Rightarrow \text{Sum of roots} > 0 \Rightarrow -\frac{[3 - y]}{y - 1} > 0$$

$$\Rightarrow \frac{y - 3}{y - 1} > 0 \Rightarrow y < 1 \text{ or } y > 3 \dots\dots(iii)$$

$\therefore$  From (i) and (iii)

$$\text{Range of } f(x) \text{ is } \left[\frac{1}{3}, 1\right]$$

$$\text{Similarly } g(x) = \frac{x^4 - x^2 + 1}{x^4 + x^2 + 1}$$

$$\Rightarrow y = \frac{x^4 - x^2 + 1}{x^4 + x^2 + 1}$$

$$\Rightarrow x^4 y + x^2 y + y = x^4 - x^2 + 1$$

$$\Rightarrow (y - 1)x^4 + x^2(1 + y) + (y - 1) = 0$$

$$\Rightarrow (y - 1)t^2 + (1 + y)t + (y - 1) = 0$$

$$D \geq 0$$

$$\Rightarrow y^2 + 1 + 2y - 4(y^2 + 1 - 2y) \geq 0$$

$$\Rightarrow 3y^2 - 10y + 3 \leq 0$$

$$\Rightarrow y \in \left[\frac{1}{3}, 3\right]$$

Also sum roots  $> 0$

$$\Rightarrow -\frac{[y + 1]}{(y - 1)} > 0 \Rightarrow \frac{y + 1}{y - 1} < 0$$

$$\therefore y \in (-1, 1)$$

$\therefore$  Range of  $g(x)$  is  $\left[\frac{1}{3}, 1\right]$ . Hence reason is correct

$$\text{A: Let } y = \frac{\sec^4 \theta - 3 \tan^2 \theta}{\sec^4 \theta - \tan^2 \theta} = \frac{(1 + \tan^2 \theta)^2 - 3 \tan^2 \theta}{(1 + \tan^2 \theta)^2 - \tan^2 \theta}$$

$$= \frac{\tan^4 \theta - \tan^2 \theta + 1}{\tan^4 \theta + \tan^2 \theta + 1} = \frac{x^4 - x^2 + 1}{x^4 + x^2 + 1} \text{ [where } x = \tan \theta]$$

$$\therefore \text{Range is } \left[\frac{1}{3}, 1\right]$$

$\therefore$  Assertion is true and reason is the correct explanation of assertion

11. (c) A:  $\frac{x}{\tan(\theta + \alpha)} = \frac{y}{\tan(\theta + \beta)} = \frac{z}{\tan \theta + \gamma}$

$$\Rightarrow \frac{x}{y} = \frac{\tan(\theta + \alpha)}{\tan(\theta + \beta)} = \frac{\sin(\theta + \alpha) \cos(\theta + \beta)}{\cos(\theta + \alpha) \sin(\theta + \beta)}$$

Applying componendo and dividendo we get,

$$\frac{x+y}{x-y} = \frac{\sin(\theta+\alpha)\cos(\theta+\beta) + \cos(\theta+\alpha)\sin(\theta+\beta)}{\sin(\theta+\alpha)\cos(\theta+\beta) - \cos(\theta+\alpha)\sin(\theta+\beta)}$$

$$= \frac{\sin(2\theta + \alpha + \beta)}{\sin(\alpha - \beta)}$$

∴ Clearly reason is incorrect

Now  $\frac{x+y}{x-y} \cdot \sin(\alpha - \beta) = \sin(2\theta + \alpha + \beta)$

$$\Rightarrow \frac{(x+y)}{x-y} \cdot \sin(\alpha - \beta) \sin(\alpha - \beta) = \sin(2\theta + \alpha + \beta) \sin(\alpha - \beta)$$

$$\Rightarrow \frac{x+y}{x-y} \sin^2(\alpha - \beta) = \sin(2\theta + \alpha + \beta) \sin(\alpha - \beta)$$

$$= \frac{1}{2} [\cos(2\theta + 2\beta) - \cos(2\theta + 2\alpha)]$$

Similarly

$$\frac{y+z}{y-z} \sin^2(\beta - \gamma) = \frac{1}{2} [\cos(2\theta + 2\gamma) - \cos(2\theta + 2\beta)]$$

$$\text{and } \frac{z+x}{z-x} \sin^2(\gamma - \alpha) = \frac{1}{2} [\cos(2\theta + 2\alpha) - \cos(2\theta + 2\gamma)]$$

∴  $\Sigma \frac{x+y}{x-y} \sin^2(\alpha - \beta) = 0$ . Hence assertion is correct.

12. (a) **R:**  $|\sqrt{A} - \sqrt{B}| \leq \sqrt{|A - B|}$  .....(i)

Which is true for positive A and B and also reason is the correct explanation of assertion.

**Case I:**  $A \geq B$

Squaring equation (i), we get  $A + B - 2\sqrt{AB} \leq A - B$

$$\Rightarrow 2B \leq 2\sqrt{AB} \quad \Rightarrow \sqrt{B} \leq \sqrt{A}$$

⇒ Which is true.

**Case I:**  $A \leq B$

Squaring equation (i), we get  $A + B - 2\sqrt{AB} \leq B - A$

$$\Rightarrow 2A \leq 2\sqrt{AB} \quad \Rightarrow \sqrt{A} \leq \sqrt{B}$$

⇒ Which is true.

Thus reason is correct.

∴ By reason

$$\left| \sqrt{\sin^2 x + 2a^2} - \sqrt{2a^2 - 1 - \cos^2 x} \right| \leq \sqrt{|\sin^2 x + 1 + \cos^2 x|} = \sqrt{2}$$

∴ Maximum value of expression =  $\sqrt{2}$

⇒ Assertion is correct. ∴ (a)

13. (b) ∵ A, B, C, D are angles of a quadrilateral;  $A + B + C + D = 2\pi$  and  $A, B, C, D \in (0, 2\pi)$

$$\Rightarrow \frac{A}{2}, \frac{B}{2}, \frac{C}{2}, \frac{D}{2} \in (0, \pi)$$

$$\Rightarrow \sin \frac{A}{2}, \sin \frac{B}{2}, \sin \frac{C}{2}, \sin \frac{D}{2} > 0$$

∴ By A.M. ≥ G.M. we have

$$\sin \frac{A}{2} + \sin \frac{B}{2} + \sin \frac{C}{2} + \sin \frac{D}{2} \geq 4 \sqrt[4]{\sin \frac{A}{2} \cdot \sin \frac{B}{2} \cdot \sin \frac{C}{2} \cdot \sin \frac{D}{2}}$$

$$\Rightarrow \left( \frac{\sin \frac{A}{2} + \sin \frac{B}{2} + \sin \frac{C}{2} + \sin \frac{D}{2}}{4} \right)^4 \geq \sin \frac{A}{2} \cdot \sin \frac{B}{2} \cdot \sin \frac{C}{2} \cdot \sin \frac{D}{2}$$

$$\Rightarrow \sin \frac{A}{2} \cdot \sin \frac{B}{2} \cdot \sin \frac{C}{2} \cdot \sin \frac{D}{2} \leq \left( \frac{\sin \frac{A}{2} + \sin \frac{B}{2} + \sin \frac{C}{2} + \sin \frac{D}{2}}{4} \right)^4$$

Here maximum value is obtained for

$$\sin \frac{A}{2} = \sin \frac{B}{2} = \sin \frac{C}{2} = \sin \frac{D}{2} \text{ i.e., for } \frac{A}{2} = \frac{B}{2} = \frac{C}{2} = \frac{D}{2} = \frac{\pi}{4}$$

i.e.,  $A = B = C = D = \pi/2$

$$\therefore \sin \frac{A}{2} \cdot \sin \frac{B}{2} \cdot \sin \frac{C}{2} \cdot \sin \frac{D}{2} \leq \left( \frac{4 \cdot \frac{1}{\sqrt{2}}}{4} \right)^4 = \frac{1}{4}$$

$$\therefore \sin \frac{A}{2} \sin \frac{B}{2} \sin \frac{C}{2} \sin \frac{D}{2} = \frac{1}{4} \text{ for } A = B = C = D = \pi/2$$

⇒ ABCD is a rectangle

Clearly reason is correct, but does not correctly explain the assertion.

**SECTION-VIII (INTEGER TYPE ANSWERS)**

1. Let  $\mu = \sqrt{a^2 \cos^2 \theta + b^2 \sin^2 \theta} + \sqrt{a^2 \sin^2 \theta + b^2 \cos^2 \theta}$ , then maximum value of  $m^2 = 2 [a^2 + b^2]$

Minimum value of  $m^2 = (a + b)^2$

∴ Difference between maximum and minimum value of  $m^2$  is  $(a - b)^2$

Here  $a = 4, b = 3$

∴ Required difference =  $(4 - 3)^2 = 1$ .

**Ans. 1**

2. We know that  $\sin \alpha + \sin \left( \alpha + \frac{2\pi}{3} \right) + \sin \left( \alpha + \frac{4\pi}{3} \right) = 0$  and

$$\cos \alpha + \cos \left( \alpha + \frac{2\pi}{3} \right) + \cos \left( \alpha + \frac{4\pi}{3} \right) = 0$$

$$\therefore \text{Here } \beta = \frac{2\pi}{3}, \gamma = \frac{2\pi}{3}$$

$$\therefore \frac{m}{n} = \frac{2}{3}$$

⇒  $m^2 + n^2 \Rightarrow$  **Ans. 13**

3. Given that  $\frac{ax \sin \theta}{\cos^2 \theta} = \frac{by \cos \theta}{\sin^2 \theta}$

$$\Rightarrow a x \sin^3 \theta = b y \cos^3 \theta \Rightarrow \frac{\sin^3 \theta}{by} = \frac{\cos^3 \theta}{ax}$$

$$\Rightarrow \frac{\sin \theta}{(by)^{1/3}} = \frac{\cos \theta}{(ax)^{1/3}} = k$$

⇒  $\sin \theta = k \cdot (by)^{1/3}, \cos \theta = k \cdot (ax)^{1/3}$ , Also  $\sin^2 \theta + \cos^2 \theta = 1$

1.138 > Trigonometry

$$\Rightarrow k^2.(by)^{2/3} + k^2.(ax)^{2/3} = 1$$

$$\therefore k = \pm \frac{1}{\sqrt{(ax)^{2/3} + (by)^{2/3}}}$$

Case 1:  $k = \frac{1}{(ax)^{2/3} + (by)^{2/3}}; \sin \theta = \frac{(by)^{1/3}}{\sqrt{(ax)^{2/3} + (by)^{2/3}}};$

$$\cos \theta = \frac{(ax)^{1/3}}{\sqrt{(ax)^{2/3} + (by)^{2/3}}}$$

Also we have  $\frac{ax}{\cos \theta} + \frac{by}{\sin \theta} = a^2 - b^2$

$$\Rightarrow \frac{ax}{(ax)^{1/3}} \sqrt{(ax)^{2/3} + (by)^{2/3}} + \frac{b.y}{(by)^{1/3}} \sqrt{(ax)^{2/3} + (by)^{2/3}} = a^2 - b^2$$

$$\Rightarrow \sqrt{(ax)^{2/3} + (by)^{2/3}} [(ax)^{2/3} + (by)^{2/3}] = a^2 - b^2$$

$$\Rightarrow [(ax)^{2/3} + (by)^{2/3}]^{3/2} = a^2 - b^2$$

$$\Rightarrow (ax)^{2/3} + (by)^{2/3} = (a^2 - b^2)^{2/3}$$

$\therefore k = -1 \quad \therefore \text{Ans. -1}$

4.  $2 \cos A = x + \frac{1}{x} \Rightarrow x^2 - 2 \cos A x + 1 = 0$

$$\Rightarrow x = \cos A \pm i \sin A$$

Similarly  $y = \cos B \pm i \sin B$

$$\therefore \frac{x}{y} + \frac{y}{x} = \cos(A-B) + \cos(B-A) = 2 \cos(A-B)$$

Hence  $k = 2 \quad \therefore \text{Ans. 2}$

5.  $\sqrt{\sin A} + \sqrt{\sin B} + \sqrt{\sin C} = \sqrt{K \cos \frac{A}{2} \cos \frac{B}{2} \cos \frac{C}{2}}$

$$\Rightarrow \sqrt{\frac{\sqrt{3}}{2}} + \sqrt{\frac{\sqrt{3}}{2}} + \sqrt{\frac{\sqrt{3}}{2}} = \sqrt{k \left(\frac{\sqrt{3}}{2}\right)^3}$$

$[\because A = B = C = 60^\circ]$

Let  $t = \sqrt{3}/2$

$$\therefore \text{Given equation becomes } 3\sqrt{t} = \sqrt{k.t^3}$$

Squaring both sides, we get  $9t = kt^3$

$$\Rightarrow kt^2 = 9$$

$$\Rightarrow k \cdot \frac{3}{4} = 9 \quad \Rightarrow k = 12$$

$\therefore \text{Ans. 12}$

6. Using  $\sin 2x = 2 \sin x \cdot \cos x$

$$= \sqrt{4 \sin^4 \theta + 4 \sin^2 \theta \cdot \cos^2 \theta} + \left[ 2 \cos \left( \frac{\pi}{4} + \frac{\theta}{4} \right) \right]^2$$

$$= \sqrt{4 \sin^2 \theta + (\sin^2 \theta \cdot \cos^2 \theta)} + \left[ \sqrt{2} \left( \cos \frac{\theta}{2} - \sin \frac{\theta}{2} \right) \right]^2$$

$$= 2 \sin \theta + 2(1 - \sin \theta) = 2.$$

$\therefore \text{Ans. 2}$

7.  $\sum_{k=1}^{n-1} {}^n C_k [\cos kx \cdot \cos(n+k)x + \sin(n-k)x \cdot \sin(2n-k)x] \dots (i)$

$$= (2^n - k) \cos nx$$

$$\text{L.H.S.} = \sum_{k=1}^{n-1} \frac{{}^n C_k}{2} [\cos(k+n+k)x + \cos(k-n-k)x + \cos(2n-k-n+k)x - \cos(2n-k+n-k)x]$$

$$= \sum_{k=1}^{n-1} \frac{{}^n C_k}{2} [\cos(2k+n)x + \cos nx + \cos(n)x - \cos(3A-2k)x]$$

$$= \sum_{k=1}^{n-1} \frac{{}^n C_k}{2} [\cos(n+2k)x - \cos(3n-2k)x + 2 \cos nx]$$

$$= \sum_{k=1}^{n-1} \frac{{}^n C_k}{2} \left[ 2 \sin \left[ \frac{n+2k+3n-2k}{2} \right] x \cos \left[ \frac{3n-2k-n-2k}{2} \right] x + 2 \cos nx \right]$$

$$= \sum_{k=1}^{n-1} \frac{{}^n C_k}{2} [2 \sin 2nx \sin(n-2k)x + 2 \cos nx]$$

$$= \sum_{k=1}^{n-1} {}^n C_k [4 \sin x \cos nx \sin(n-2k)x + 2 \cos nx]$$

$$= \sum_{k=1}^{n-1} {}^n C_k [(\cos nx)(2 \sin nx \sin(n-2k)x + 1)]$$

$$= \sum_{k=1}^{n-1} {}^n C_k [\cos nx [\cos(2kx) - \cos(2n-2k)x + 1]]$$

$$= \sum_{k=1}^{n-1} {}^n C_k \cos nx [\cos 2kx - \cos 2(n-k)x] + \sum_{k=1}^{n-1} {}^n C_k \cos nx$$

Now,  $\sum_{k=1}^{n-1} {}^n C_k \cos nx [\cos 2kx - \cos 2(n-k)x]$

$$= \sum_{k=1}^{n-1} {}^n C_{n-k} \cos nx [\cos 2(n-k)x - \cos 2(k)x]$$

$\Rightarrow$  It equal 0

$$= \sum_{k=1}^{n-1} {}^n C_k \cos nx = \cos nx ({}^n C_1 + {}^n C_2 + \dots + {}^n C_{n-1})$$

$$= \cos nx [(2^n - 2)] = ((2^n) - k) \cos nx \text{ (given)}$$

$\Rightarrow k = 2$

8. As we know that  $\cos 36^\circ = \frac{\sqrt{5} + 1}{4}$

$$\cot \left( 7 \frac{1}{2} \right)^\circ = \sqrt{2} + \sqrt{3} + \sqrt{4} + \sqrt{6}$$

$$\therefore 4 \cos 36^\circ + \cot \left( \frac{15}{2} \right)^\circ$$

$$= \sqrt{5} + 1 + \sqrt{2} + \sqrt{3} + \sqrt{4} + \sqrt{6}$$

$$= \sqrt{1} + \sqrt{2} + \sqrt{3} + \sqrt{4} + \sqrt{5} + \sqrt{6} = \sum_{\gamma=1}^6 \sqrt{\gamma} \Rightarrow k = 6$$

$\therefore \text{Ans. 6}$

9.  $\tan(6\theta) = 4/3 \Rightarrow \sec^2(6\theta) = 1 + \frac{16}{9} = \frac{25}{9}$

$$\therefore \cos(6\theta) = \pm \frac{3}{5}$$

Case 1:  $\cos(6\theta) = \frac{3}{5} \Rightarrow 3 = 5 \cos(6\theta)$

$$\Rightarrow \sin(6\theta) = 4/5 \quad \Rightarrow 4 = 5 \sin(6\theta)$$

$$\text{Now } \frac{1}{2}[4\operatorname{cosec}(2\theta) - 3\sec(2\theta)]$$

$$= \frac{1}{2} \left[ \frac{4\cos(2\theta) - 3\sin(2\theta)}{\sin(2\theta)\cos(2\theta)} \right]$$

$$= \frac{5\sin(6\theta)\cos(2\theta) - 5\cos(6\theta)\sin(2\theta)}{2\sin(2\theta)\cos(2\theta)}$$

$$= \frac{5[\sin(4\theta)]}{\sin(4\theta)} = 5$$

∴ **Ans. 5**

10. Roots of  $x^3 - 7x^2 + 5 = 0$  .....(i)

are  $\tan\alpha, \tan\beta, \tan\gamma$

Now to form an equation whose roots are  $\sec^2\alpha, \sec^2\beta, \sec^2\gamma$

$$\text{Put } y = 1 + x^2 \quad \Rightarrow x = \sqrt{y-1}$$

$$\therefore \text{Equation (1) becomes } (\sqrt{y-1})^3 - 7(y-1) + 5 = 0$$

$$\therefore (y-1)\sqrt{y-1} = 7y - 12$$

$$\text{Squaring both side we get } (y-1)^2(y-1) \\ = 49y^2 + 144 - 168y$$

$$\Rightarrow y^3 - y^2 + y - 1 - 2y^2 + 2y - 49y^2 - 144 + 168y = 0$$

$$\Rightarrow y^3 - 52y^2 + 171y - 145 = 0 \dots\dots(ii)$$

Now roots of equation (ii) are  $\sec^2\alpha, \sec^2\beta, \sec^2\gamma$

$$\therefore \sec^2\alpha \cdot \sec^2\beta \cdot \sec^2\gamma = \text{Product of roots of equation (ii)} = 145$$

∴ **Ans 145**

11.  $\sin\left(\frac{23}{24}\pi\right) = \sin\left(\pi - \frac{\pi}{24}\right) = \sin\left(\frac{\pi}{24}\right)$

$$\text{Now } \cos\left(\frac{\pi}{12}\right) = \cos(15^\circ) = \frac{\sqrt{3}+1}{2\sqrt{2}}$$

∴ Using  $1 - \cos\theta = 2\sin^2(\theta/2)$ , we get

$$2\sin^2\left(\frac{\pi}{24}\right) = 1 - \cos\left(\frac{\pi}{12}\right)$$

$$\Rightarrow \sin^2\left(\frac{\pi}{24}\right) = \frac{1 - \left(\frac{\sqrt{3}+1}{2\sqrt{2}}\right)}{2}$$

$$\Rightarrow \sin\left(\frac{\pi}{24}\right) = \sqrt{\frac{2\sqrt{2} - \sqrt{3} - 1}{4\sqrt{2}}}$$

$$\therefore p = 2, q = 3, r = 2 \quad \therefore p^2 - q^2 - r^2 = 9$$

∴ **Ans. 9**

12.  $\sin x + \sin^2 x + \sin^3 x = 1 \Rightarrow \sin x + \sin^3 x = \cos^2 x$

Squaring both sides we get  $\sin^2 x + \sin^6 x + 2\sin^4 x = \cos^4 x$

$$\Rightarrow 1 - \cos^2 x + (1 - \cos^2 x)^3 + 2(1 - \cos^2 x)^2 = \cos^4 x$$

$$\Rightarrow 1 - \cos^2 x + 1 - \cos^6 x - 3\cos^2 x(1 - \cos^2 x) + 2(1 + \cos^4 x - 2\cos^2 x) = \cos^4 x$$

$$\Rightarrow 2 - \cos^6 x - \cos^2 x - 3\cos^2 x + 3\cos^4 x + 2 + 2\cos^4 x - 4\cos^2 x - \cos^4 x = 0$$

$$\Rightarrow 4 - \cos^6 x - 8\cos^2 x + 4\cos^4 x = 0$$

$$\Rightarrow \cos^6 x = 4 - 8\cos^2 x - 4\cos^4 x$$

$$\Rightarrow \cos^6 x - 4\cos^4 x + 8\cos^2 x = 4$$

$$\Rightarrow \text{Required value} = 4$$

∴ **Ans. 4**

13.  $\cot \frac{\pi}{24} = \frac{1 + \cos 15^\circ}{\sin 15^\circ} = \frac{1 + \frac{\sqrt{3}+1}{2\sqrt{2}}}{\frac{\sqrt{3}-1}{2\sqrt{2}}} = \frac{2\sqrt{2} + \sqrt{3} + 1}{\sqrt{3}-1}$

$$= \frac{(2\sqrt{2} + \sqrt{3} + 1)\sqrt{3} + 1}{2} = \sqrt{6} + \sqrt{4} + \sqrt{3} + \sqrt{2}$$

$$= \sqrt{2} + \sqrt{3} + \sqrt{4} + \sqrt{6}$$

$$= \sqrt{p} + \sqrt{q} + \sqrt{r} + \sqrt{s} \quad (\text{given, } p < q < r < s)$$

$$\Rightarrow p = 2, q = 3, r = 4, s = 6$$

$$\Rightarrow p + q + r + s = 3$$

14. Divide by  $\cos^4 \alpha$

$$\Rightarrow 15 \tan^4 \alpha + 10 = 6 \sec^4 \alpha$$

$$\Rightarrow 15 \tan^4 \alpha + 10 = 6(1 + \tan^2 \alpha)^2$$

$$\Rightarrow (3 \tan^2 \alpha - 2)^2 = 0$$

$$\therefore \tan^2 \alpha = 2/3$$

$$\Rightarrow \operatorname{cosec}^2 \alpha = 5/2; \sec^2 \alpha = 5/3$$

$$\Rightarrow 8 \operatorname{cosec}^6 \alpha + 27 \sec^6 \alpha - 241$$

$$= 8 \left( \frac{125}{8} \right) + 27 \left( \frac{125}{8} \right) - 241 = 9$$

15. ∴  $\cos A + \cos B + \cos C = \frac{7}{4}$

$$\Rightarrow 1 + 4 \sin \frac{A}{2} \sin \frac{B}{2} \sin \frac{C}{2} = \frac{7}{4}$$

$$4 \sin \frac{A}{2} \sin \frac{B}{2} \sin \frac{C}{2} = \frac{3}{4}$$

$$\therefore \frac{R}{r} = \frac{3}{4} \quad \Rightarrow k = 3$$

∴ **Ans. 3**

16. ∴  $E = (\cos^2 x + \sin^2 x)^2 - 2\sin^2 x \cos^2 x - k^2(\cos^2 x - \sin^2 x)^2$

$$= 1 - 2\sin^2 x \cos^2 x - k^2[1 - 4\sin^2 x \cos^2 x]$$

$$= (1 - k^2) - 2\sin^2 x \cos^2 x(1 - 2k^2)$$

$$\therefore E \text{ is independent of } x \text{ if } k^2 = \frac{1}{2}$$

$$\therefore E = \frac{1}{2}$$

$$\therefore t = 2$$

∴ **Ans. 2**

17.  $\tan \frac{\pi}{12} = 2 - \sqrt{3} = \sqrt{4} - \sqrt{3}$

$$\tan \frac{\pi}{8} = \sqrt{2} - 1 = \sqrt{2} - \sqrt{1}$$

1.140 > Trigonometry

$$\sin \frac{\pi}{10} = \frac{\sqrt{5}-1}{4}$$

$\Rightarrow P=4, Q=3, R=2, S=1$  &  $T=5$   
 $\Delta PQT$  is right angled triangle

$$\therefore \text{Area} = \frac{1}{2} \times 3 \times 4 = 6$$

$$\text{Area of rectangle} = 2 \times 1 = 2$$

$$\therefore \text{Required sum} = 6 + 2 = 8$$

$\therefore$  **Ans. 8**

18.  $\angle B = 60^\circ, \angle C = 45^\circ$

$$\text{Now } \frac{BD}{\angle BAD} = \frac{AD}{\sin 60^\circ}$$

$$\therefore \angle BAD = \frac{BD}{AD} \times \frac{\sqrt{3}}{2}$$

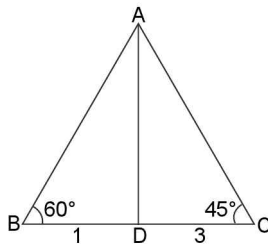

$$\text{Also } \frac{CD}{\angle CAD} = \frac{AD}{\sin 45^\circ}$$

$$\Rightarrow \angle CAD = \frac{CD}{AD} \times \frac{1}{\sqrt{2}} \quad \dots\dots(ii)$$

$$\text{Dividing (i) by (ii), we get } \frac{\angle BAD}{\angle CAD} = \frac{BD \cdot \sqrt{3} / 2}{CD / \sqrt{2}} = \frac{BD}{CD} \cdot \frac{\sqrt{3}}{\sqrt{2}}$$

$$= \frac{1}{\sqrt{6}} = \frac{1}{\sqrt{k}} \text{ (given)} \Rightarrow k = 6$$

19.  $x = y \cos \frac{2\pi}{3} = z \cos \frac{4\pi}{3}$

$$\Rightarrow x = -\frac{y}{2} = -\frac{z}{2} \Rightarrow y = z = -2x$$

$$\therefore xy + yz + zx = -2x^2 + 4x^2 - 2x^2 = 0$$

$\dots (i)$

20.  $(1 - \cot 1^\circ)(1 - \cot 44^\circ)$

$$= 1 - \cot 1^\circ - \cot 44^\circ + \cot 1^\circ \cot 44^\circ$$

$$\cot 45^\circ = \cot (1^\circ + 44^\circ) = \frac{\cot 1^\circ \cot 44^\circ - 1}{\cot 1^\circ + \cot 44^\circ}$$

$$\therefore 1 - \cot 1^\circ - \cot 44^\circ + \cot 1^\circ \cot 44^\circ = 2$$

Similarly  $(1 - \cot 2^\circ)(1 - \cot 43^\circ) = 2$  and so on

Total pairs are 22

$$\therefore (1 - \cot 1^\circ)(1 - \cot 2^\circ) \dots$$

$$(1 - \cot 44^\circ) = 2^{22} = 2^n$$

$$\Rightarrow n = 22$$

# Trigonometric Equations

# 2

CHAPTER

## INTRODUCTION

We have already learnt trigonometric identities. What is trigonometric equation? What is the need of learning trigonometric equation. How are the trigonometric equations distinct from the trigonometric identities. These are some of the questions which will come to your mind when you come across the problem related to trigonometric equations and begin to study this topic.

The need for study of these equations will be realised as we proceed further. Whereas any Trigonometric Identity is satisfied for every value of the unknown angle, the Trigonometric Equation is satisfied only for some values of unknown angle. e.g.,  $1 + \tan^2\theta = \sec^2\theta$ ,  $\sin 3\theta = 3\sin\theta - 4\sin^3\theta$  are trigonometric identities and  $\sin 3x = \sin x$  is a trigonometric equation as it would be satisfied for some (discrete real) values of  $x$ .

Thus every trigonometric equation is not trigonometric identity but every identity is a trigonometric equation. This satisfies our first query. Application of trigonometric equation lies in dealing with Heights and Distance, Architectural design, Mechanical engineering, Astronomy, Surveying and numerous other fields of science and technologies.

Specially discussing the solutions of trigonometric equation as well as inequalities geometrically is interesting and if practiced efficiently gives very quick and convenient visual way of analysing the equations and inequalities.

## TRIGONOMETRIC EQUATIONS

The equations involving one or more trigonometric functions of unknown angles are known as trigonometric equations. e.g.,  $\cos\theta = 0$ ,  $\cos^2\theta - 4\cos\theta = 1$ ,  $\sin^2\theta + \sin\theta = 2$ ,  $\cos 2\theta - \sin 3\theta = 1$ .

Trigonometric identity is an equation which is satisfied by every value of unknown angle whereas trigonometric equation is satisfied only for some (finite/infinite) values of unknown angles.

e.g.,  $\operatorname{cosec}^2\theta - \cot^2\theta = 1$ ,  $\sin^2\theta + \cos^2\theta = 1$ ,  $\cos 2\theta = \cos^2\theta - \sin^2\theta$  are trigonometric identities.

## Solution of Trigonometric Equations

A solution of a trigonometric equation is the value of the unknown angle that satisfies the equation.

$$\text{e.g., } \sin\theta = \frac{1}{\sqrt{2}}$$

$$\Rightarrow \theta = \frac{\pi}{4} \text{ or } \theta = \frac{\pi}{4}, \frac{3\pi}{4}, \frac{9\pi}{4}, \frac{11\pi}{4}, \dots$$

Thus, the trigonometric equation may have infinite number of solutions and are classified as:

- (i) Particular Solution
- (ii) Principal Solution and
- (iii) General Solution

## Particular Solution

Any arbitrary value of unknown angle which satisfies the equation is called particular solution.

e.g.,  $\theta = \pi/4$  is a particular solution of equation  $\sin\theta + \cos\theta = \sqrt{2}$

## Principal Solution

Principal solution is the value of unknown angle belonging to the principal domain of trigonometric function. It is numerically the least value of the angle. The principal domain for a trigonometric function is defined as an interval belonging to the domain of said function in which it is

2.2 ➤ Trigonometry

bijjective i.e., strictly monotonic and takes up all possible values, conventionally. It is considered nearest to origin preferable positive. e.g., the equation  $\sin\theta = 1/2$  is satisfied by the angle  $\theta = -7\pi/6, \pi/6, 5\pi/6, ..$  etc., but only  $\pi/6$  lies in the principal domain, so  $\pi/6$  is principal solution and general solution is always expressed in terms of principal solution. Principal domain for trigonometric functions are given below:

$\cos x$	$[0, \pi]$
$\sec x$	$[0, \pi] \sim \{\pi/2\}$
$\tan x$	$(-\pi/2, \pi/2)$
$\cot x$	$(0, \pi)$

**Trigonometric Function    Principal Domain**

$\sin x$	$[-\pi/2, \pi/2]$
$\operatorname{cosec} x$	$[-\pi/2, \pi/2] \sim \{0\}$

**General Solution**

Since trigonometric functions are periodic, a solution can be generalized by means of periodicity of the trigonometric functions taking the help of principal solution. The solution consisting of ‘all possible particular solutions’ of a trigonometric equation is called ‘general solution’.

**ILLUSTRATION 1:** Find the General, Principal and Particular solution of the trigonometric equation

- (i)  $\sin \theta = 0$     (ii)  $\sin \theta = 1$     (iii)  $\sin \theta = -1$

**SOLUTION:**  $\sin \theta = 1$

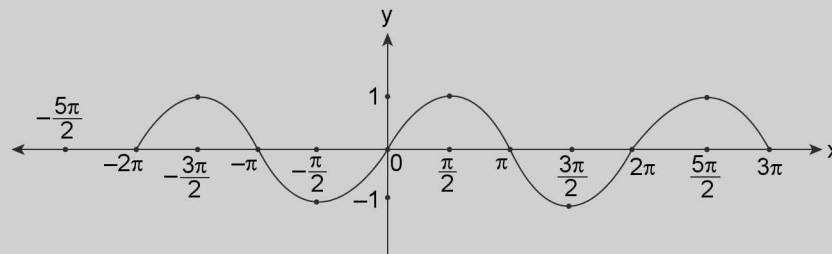

FIGURE 2.1

	$\sin \theta = 0$	$\sin \theta = 1$	$\sin \theta = -1$
Particular solution	$3\pi$	$\frac{5\pi}{2}$	$-\frac{5\pi}{2}$
Principal solution	$0$	$\frac{\pi}{2}$	$-\frac{\pi}{2}$
General solution	$n\pi, n \in \mathbb{Z}$	$2n\pi + \frac{\pi}{2}; n \in \mathbb{R}$	$2n\pi - \frac{\pi}{2}; n \in \mathbb{Z}$

**ILLUSTRATION 2:** Find the General, Principal and Particular solution of the trigonometric equation

- (i)  $\cos \theta = 0$     (ii)  $\cos \theta = 1$     (iii)  $\cos \theta = -1$

**SOLUTION:**  $\cos \theta = 1$

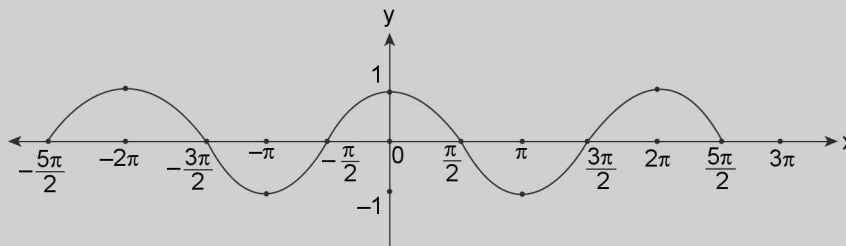

FIGURE 2.2

	$\cos \theta = 0$	$\cos \theta = 1$	$\cos \theta = -1$
Particular solution	$\frac{7\pi}{2}$	$4\pi$	$5\pi$
Principal solution	$\frac{\pi}{2}$	$0$	$\pi$
General solution	$2n\pi \pm \frac{\pi}{2}; n \in \mathbb{Z}$	$2n\pi; n \in \mathbb{Z}$	$(2n + 1)\pi; n \in \mathbb{Z}$

**ILLUSTRATION 3:** Find the General, Principal and Particular solution of the trigonometric equation

- (i)  $\tan \theta = 0$ .    (ii)  $\tan \theta = 1$     (iii)  $\tan \theta = -1$

**SOLUTION:**  $\tan \theta = 1$

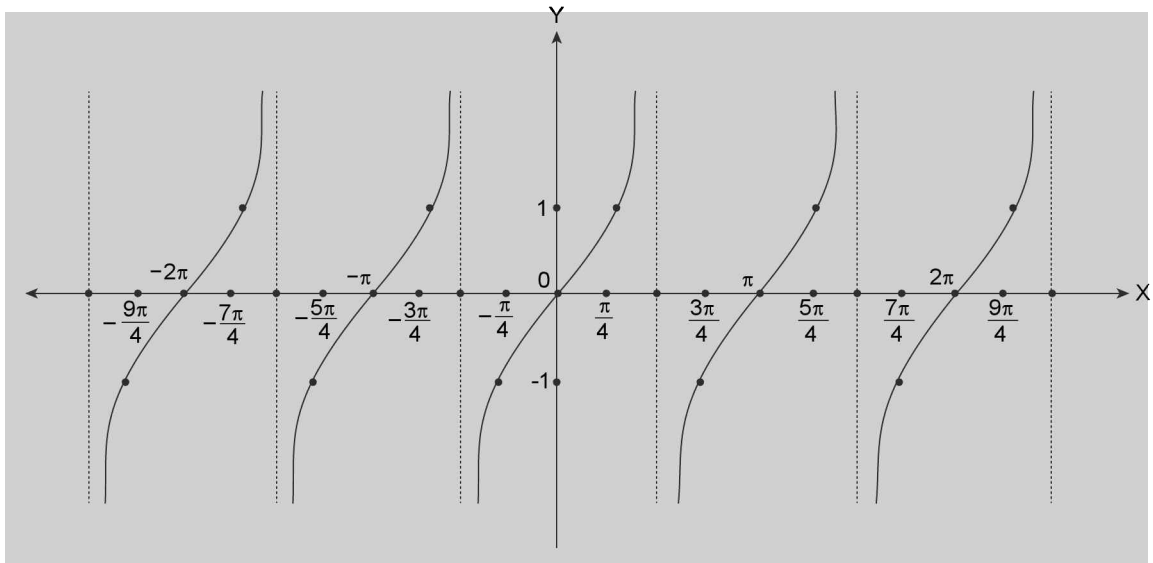

**FIGURE 2.3**

	$\tan \theta = 0$	$\tan \theta = 1$	$\tan \theta = -1$
Particular solution	$5\pi$	$\frac{5\pi}{4}$	$\frac{7\pi}{4}$
Principal solution	$0$	$\frac{\pi}{4}$	$-\frac{\pi}{4}$
General solution	$n\pi; n \in \mathbb{Z}$	$n\pi + \frac{\pi}{4}; n \in \mathbb{Z}$	$n\pi - \frac{\pi}{4}; n \in \mathbb{Z}$

### General solution of equation $\sin \theta = k$

**Theorem 1:**  $\sin \theta = 0 \Leftrightarrow \theta = n\pi$ , where  $n \in \mathbb{Z}$ .

**Proof:** We know that  $\sin \theta = 0$  for all integral multiples of  $\pi$ .

$$\therefore \sin \theta = 0 \Leftrightarrow \theta = 0, \pm \pi, \pm 2\pi, \pm 3\pi, \dots$$

$$\Leftrightarrow \theta = n\pi, n \in \mathbb{Z}.$$

$$\therefore \sin \theta = 0 \Leftrightarrow \theta = n\pi, n \in \mathbb{Z}.$$

**Theorem 2:** If  $\theta = \alpha$  be one solution of the equation  $\sin \theta = k$  where  $-1 \leq k \leq 1$  i.e., the general solution is given



## 2.4 > Trigonometry

by  $\sin \theta = \sin \alpha \Leftrightarrow \theta = n\pi + (-1)^n \alpha$ , where  $n \in \mathbb{Z}$  and  $\alpha \in [-\pi/2, \pi/2]$ .

**Proof:** We have,  $\sin \theta = \sin \alpha$ , where

$$\alpha \in \left[-\frac{\pi}{2}, \frac{\pi}{2}\right]$$

$$\Leftrightarrow \sin \theta - \sin \alpha = 0 \Leftrightarrow 2 \cos \left(\frac{\theta + \alpha}{2}\right) \sin \left(\frac{\theta - \alpha}{2}\right) = 0.$$

$$\Leftrightarrow \cos \left(\frac{\theta + \alpha}{2}\right) = 0 \text{ or } \sin \left(\frac{\theta - \alpha}{2}\right) = 0$$

$$\Leftrightarrow \left(\frac{\theta + \alpha}{2}\right) = (2m + 1) \frac{\pi}{2}, m \in \mathbb{Z} \text{ or } \left(\frac{\theta - \alpha}{2}\right) = m\pi,$$

$$m \in \mathbb{Z}.$$

$$\Leftrightarrow (\theta + \alpha) = (2m + 1) \pi, m \in \mathbb{Z} \text{ or}$$

$$(\theta - \alpha) = 2m \pi, m \in \mathbb{Z}$$

$$\Leftrightarrow \theta = (2m + 1) \pi - \alpha, m \in \mathbb{Z} \text{ or } \theta = (2m \pi) + \alpha, m \in \mathbb{Z}$$

$$\Leftrightarrow \theta = (\text{any odd multiple of } \pi) - \alpha \text{ or}$$

$$\theta = (\text{any even multiple of } \pi) + \alpha$$

$$\Leftrightarrow \theta = n\pi + (-1)^n \alpha, \text{ where } n \in \mathbb{Z} \therefore \sin \theta = \sin \alpha$$

$$\Leftrightarrow \theta = n\pi + (-1)^n \alpha, \text{ where } n \in \mathbb{Z} \text{ and } \alpha \in \left[-\frac{\pi}{2}, \frac{\pi}{2}\right]$$

### Graphically

Clearly, there are two sets of solutions.

$$\theta = \alpha, 2\pi + \alpha, 4\pi + \alpha, \dots = 2k\pi + \alpha \text{ and}$$

$$\theta = \pi - \alpha, 3\pi - \alpha, 5\pi - \alpha, \dots = (2k + 1)\pi - \alpha$$

So  $(\theta \text{ is even multiple of } \pi) + \alpha$  or  $(\text{odd multiple of } \pi) - \alpha$ , taking union of these two, we get the general solution  $\theta = n\pi + (-1)^n \alpha$ .

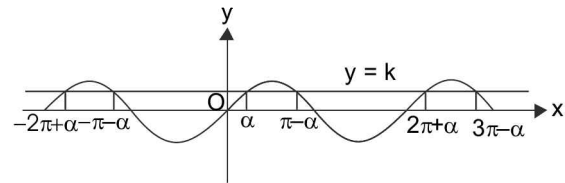

FIGURE 2.4

**ILLUSTRATION 4:** Find the general solution of equation  $\sin \theta = 1/2$ .

**SOLUTION:** We know that  $\sin \pi/6 = 1/2$ . So equation reduces to  $\sin \theta = \sin \pi/6$

So general solution of the given equation is  $\theta = n\pi + (-1)^n \pi/6, n \in \mathbb{Z}$ .

**ILLUSTRATION 5:** Solve  $\sin 2x = \sqrt{2} \cos x$

**SOLUTION:** We can write the given equation as  $2\sin x \cos x - \sqrt{2} \cos x = 0$

$$\Rightarrow \sqrt{2} \cos x (\sqrt{2} \sin x - 1) = 0 \Rightarrow \cos x = 0 \text{ or } \sin x = \frac{1}{\sqrt{2}}$$

$$\text{i.e., } x = (2n+1) \frac{\pi}{2}, n \in \mathbb{Z} \text{ or } x = k\pi + (-1)^k \frac{\pi}{4}, k \in \mathbb{Z}$$

union of the above two constitute the general solution.

**ILLUSTRATION 6:** If  $\sin \alpha, 1, \cos 2\alpha$  are in G.P, then find the general solution for  $\alpha$ .

**SOLUTION:** Since  $\sin \alpha, 1, \cos 2\alpha$  are in G.P.

$$\Rightarrow 1 = \sin \alpha \cos 2\alpha \Rightarrow 1 = \sin \alpha (1 - 2\sin^2 \alpha)$$

$$\Rightarrow 2\sin^3 \alpha - \sin \alpha + 1 = 0 \Rightarrow (\sin \alpha + 1) (2\sin^2 \alpha - 2\sin \alpha + 1) = 0$$

$$\Rightarrow \sin \alpha + 1 = 0 \left( \because 2\sin^2 \alpha - 2\sin \alpha + 1 = 2 \left( \left( \sin \alpha - \frac{1}{2} \right)^2 + \frac{1}{4} \right) \neq 0 \right)$$

$$\therefore \sin \alpha = -1 \Rightarrow \sin \alpha = \sin(-\pi/2)$$

$$\Rightarrow \alpha = n\pi + (-1)^n \left(-\frac{\pi}{2}\right), n \in \mathbb{Z} \Rightarrow \alpha = n\pi + (-1)^{n+1} \left(\frac{\pi}{2}\right), n \in \mathbb{Z}$$

**ILLUSTRATION 7:** Solve  $\cos^2\theta - \sin\theta = -1$

**SOLUTION:** Given  $\cos^2\theta - \sin\theta = -1$  and applying the relation  $\cos^2\theta = 1 - \sin^2\theta$  and writing the given equation as a quadratic equation in  $\sin\theta$ , we get  $\sin^2\theta + \sin\theta - 2 = 0$

Factorizing, we get  $(\sin\theta - 1)(\sin\theta + 2) = 0$

Thus  $\sin\theta = 1$  or  $-2$ , and since  $\sin\theta$  cannot be equal to  $-2$

$\Rightarrow \sin\theta = 1 \Rightarrow \theta = n\pi + (-1)^n \pi/2, n \in \mathbb{Z}$

**ILLUSTRATION 8:** Solve the equation  $\sin(x + \pi/4) = \sin 2x$

**SOLUTION:** Considering the value of  $2x$  as a particular solution of  $x + \pi/4$  the general solution is given by  $x + \pi/4 = n\pi + (-1)^n 2x, n \in \mathbb{Z}$  since the sine relation is involved

Solving this for  $x$ , we get  $x = \frac{n\pi - \pi/4}{1 - (-1)^n 2}, n \in \mathbb{Z}$

Taking two cases  $n = 2m$  and  $n = 2m + 1$ , we get

$$x = \frac{\pi}{4} + 2m\pi, m \in \mathbb{Z} \quad \text{or} \quad \frac{(2m+1)\pi - \pi/4}{3}, m \in \mathbb{Z}$$

## TEXTUAL EXERCISE-1 (SUBJECTIVE)

1. Find the general solution of the following:

(a)  $\sin \theta = \frac{1}{\sqrt{2}}$

(b)  $\sin \theta = 1$

(c)  $\sin \theta = -1$

2. Solve the equation:

(a)  $\sin 9\theta = \sin \theta$       (b)  $\sec \theta = -\sqrt{2}$

3. Solve the following equations for  $\theta$ .

(a)  $\sin 3\theta + 5\sin \theta = 0$

(b)  $\sin \theta + \sin 7\theta = \sin 4\theta$

(c)  $\cos \theta - \sin 3\theta = \cos 2\theta$

(d)  $\sin 7\theta = \sin \theta + \sin 3\theta$

4. Solve

(a)  $\sin \frac{(n+1)}{2} \theta = \sin \frac{(n-1)}{2} \theta + \sin \theta$

(b)  $\sin m\theta + \sin n\theta = 0$

5.  $\sin \theta + \sin 3\theta + \sin 5\theta = 0$

## Answer Keys

1. (a)  $\theta = (8n+1)\frac{\pi}{4}, (8n+3)\frac{\pi}{4}, n \in \mathbb{Z}$  (b)  $2n\pi + \frac{\pi}{2}, n \in \mathbb{Z}$

(c)  $2n\pi - \frac{\pi}{2}, n \in \mathbb{Z}$

2. (a)  $\theta = \frac{n\pi}{4}, (2n+1)\frac{\pi}{10}, n \in \mathbb{Z}$  (b)  $\theta = 2n\pi \pm \frac{3\pi}{4}, n \in \mathbb{Z}$

3. (a)  $n\pi, n \in \mathbb{Z}$  (b)  $\frac{n\pi}{4}$  or  $\frac{1}{3}\left(2n\pi \pm \frac{\pi}{3}\right), n \in \mathbb{Z}$

(c)  $\frac{2n\pi}{3}$  or  $\left(n + \frac{1}{4}\right)\pi$  or  $\left(2n - \frac{1}{2}\right)\pi, n \in \mathbb{Z}$

(d)  $\frac{n\pi}{3}$  or  $\left(2n \pm \frac{1}{3}\right)\frac{\pi}{4}, n \in \mathbb{Z}$  4. (a)  $2m\pi$  or  $\frac{4m\pi}{n \pm 1}, m \in \mathbb{Z}$

(b)  $\frac{2r\pi}{m+n}$  or  $(2r+1)\frac{\pi}{m-n}, r \in \mathbb{Z}$

5.  $\frac{n\pi}{3}$  or  $\left(n \pm \frac{1}{3}\right)\pi, n \in \mathbb{Z}$

**General solution of equation  $\cos \theta = k$**

**Theorem 1:**  $\cos \theta = 0 \Leftrightarrow \theta = (2n + 1)\frac{\pi}{2}, n \in \mathbb{Z}$ .

**Proof:** We know that  $\cos \theta = 0$  for all odd multiples of  $\frac{\pi}{2}$ .

$$\therefore \cos \theta = 0 \Leftrightarrow \theta = \pm \frac{\pi}{2}, \pm \frac{3\pi}{2}, \pm \frac{5\pi}{2}, \dots$$

$$\Leftrightarrow \theta = (2n + 1)\frac{\pi}{2}, n \in \mathbb{Z}$$

$$\therefore \cos \theta = 0 \Leftrightarrow \theta = (2n + 1)\frac{\pi}{2}, n \in \mathbb{Z}$$

**Theorem 2:** If  $-1 \leq k \leq 1$  and  $\alpha$  is one solution of  $\cos \theta = k$ , then the general solution is given by  $\cos \theta = \cos \alpha \Leftrightarrow \theta = 2n\pi \pm \alpha, n \in \mathbb{Z}$  and  $\alpha \in [0, \pi]$ .

**Proof:** We have,  $\cos \theta = \cos \alpha$ , where  $\alpha \in [0, \pi]$

$$\Leftrightarrow \cos \theta - \cos \alpha = 0$$

$$\Leftrightarrow -2 \sin \left( \frac{\theta + \alpha}{2} \right) \cdot \sin \left( \frac{\theta - \alpha}{2} \right) = 0.$$

$$\Leftrightarrow \sin \left( \frac{\theta + \alpha}{2} \right) = 0 \text{ or } \sin \left( \frac{\theta - \alpha}{2} \right) = 0$$

$$\Leftrightarrow \left( \frac{\theta + \alpha}{2} \right) = n\pi \quad \text{or} \quad \left( \frac{\theta - \alpha}{2} \right) = n\pi, n \in \mathbb{Z}$$

$$\Leftrightarrow \theta + \alpha = 2n\pi \quad \text{or} \quad \theta - \alpha = 2n\pi, n \in \mathbb{Z}$$

$$\Leftrightarrow \theta = 2n\pi - \alpha \quad \text{or} \quad \theta = 2n\pi + \alpha, n \in \mathbb{Z}$$

$$\Leftrightarrow \theta = 2n\pi \pm \alpha, n \in \mathbb{Z} \quad \therefore \cos \theta = \cos \alpha$$

$$\Leftrightarrow \theta = 2n\pi \pm \alpha, n \in \mathbb{Z}, \text{ where } \alpha \in [0, \pi]$$

**Graphically**

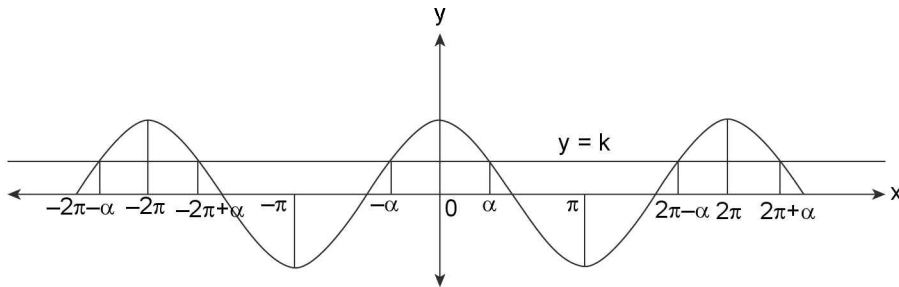

**FIGURE 2.5**

Clearly, we have solutions of the type

$$\theta = \alpha, 2\pi + \alpha, 4\pi + \alpha, \dots = 2k\pi + \alpha$$

$$\theta = -\alpha, 2\pi - \alpha, 4\pi - \alpha, \dots = 2k\pi - \alpha$$

taking union of these two, we get the general solution  $\theta = 2n\pi \pm \alpha$ .

**REMARKS**

1. The solution of  $\cos \theta = 1$  is  $\theta = 2n\pi \pm 0 = 2n\pi, n \in \mathbb{Z}$ .
2. The solution of  $\cos x = 0$  is  $x = 2n\pi \pm \pi/2, n \in \mathbb{Z}$ . That is  $x = (4n \pm 1)\pi/2, n \in \mathbb{Z}$ . Since numbers of the form  $4n + 1, n \in \mathbb{Z}$  and those of the form  $4n - 1, n \in \mathbb{Z}$  together exhaust all odd integers, we may write the solutions more compactly in the form  $x = (2n + 1)\pi/2, n \in \mathbb{Z}$ .
3. The solution of  $\cos \theta = -1$  is given by  $\theta = (2n\pi \pm \pi), n \in \mathbb{Z}$ . That is  $\theta = (2n \pm 1)\pi, n \in \mathbb{Z}$ . Now numbers of the form  $2n + 1, n \in \mathbb{Z}$  are the same as those of the form  $2n - 1, n \in \mathbb{Z}$  because both are collections of all odd integers. Hence avoiding duplicity, we can write the solution in more simple and compact form as  $\theta = (2n + 1)\pi, n \in \mathbb{Z}$ .

**ILLUSTRATION 9:** Solve the equation  $\sin x + \sin 5x = \sin 3x$ .

**SOLUTION:** Let  $2\sin 3x \cos 2x = \sin 3x \therefore \sin 3x = 0$  or  $2\cos 2x = 1$

$$\begin{aligned} \Rightarrow \sin 3x &= 0, & \Rightarrow 3x &= n\pi \\ \Rightarrow \cos 2x &= 1/2, & \Rightarrow 2x &= 2n\pi \pm \pi/3 \\ \text{Therefore } x &= n\pi/3 & \text{or } &n\pi \pm \pi/6 \end{aligned}$$

**ILLUSTRATION 10:** Solve  $\sin 6x + \sin 4x = 0$

**SOLUTION:** Applying the formula for the sum of sine, we get  $\sin 5x \cos x = 0$  ... (i)

If  $x$  is a solution for the equation, then at least one of the following equation is true.

$$\sin 5x = 0 \text{ or } \cos x = 0 \quad \dots \text{(ii)}$$

Conversely, if  $x$  is a solution of one of the equation (ii) then it is solution of equation (i) as well.

So the equation (i) is equivalent to the equation (ii). Equation (ii) has the solutions  $x = \frac{n\pi}{5}$ ,

$$x = (2n+1)\frac{\pi}{2} \text{ where } n \in \mathbb{Z}$$

**ILLUSTRATION 11:** Find general solution of  $\cos 3\theta = \sin 2\theta$ .

**SOLUTION:** This can be solved by two different methods:

**Method-I:** We can write the given equation as  $\cos 3\theta = \cos\left(\frac{\pi}{2} - 2\theta\right)$

$$\Rightarrow 3\theta = 2n\pi \pm \left(\frac{\pi}{2} - 2\theta\right) \text{ where } n \in \mathbb{Z}$$

$$\Rightarrow 5\theta = 2n\pi + \frac{\pi}{2} \text{ and also } \theta = 2n\pi - \frac{\pi}{2}$$

$$\Rightarrow \theta = (4n+1)\frac{\pi}{10} \text{ and } \theta = (4n-1)\frac{\pi}{2} \text{ where } n \in \mathbb{Z}$$

**Method-II:**  $\sin 2\theta = \sin\left(\frac{\pi}{2} - 3\theta\right) \Rightarrow 2\theta = n\pi + (-1)^n\left(\frac{\pi}{2} - 3\theta\right)$

**Case I:** When  $n$  is even i.e.,  $n = 2m$ , where  $m \in \mathbb{Z}$

$$2\theta = 2m\pi + \left(\frac{\pi}{2} - 3\theta\right) \Rightarrow \theta = (4m+1)\frac{\pi}{10} \text{ where } m \in \mathbb{Z}$$

**Case II:** When  $n$  is odd,  $n = (2m+1)$  for all  $m \in \mathbb{Z}$

$$2\theta = (2m+1)\pi - \left(\frac{\pi}{2} - 3\theta\right) \Rightarrow \theta = -(4m+1)\frac{\pi}{2} \text{ where } m \in \mathbb{Z}$$

**ILLUSTRATION 12:** Solve  $\sin^2 x + \sin^2 2x = 1$

**SOLUTION:** The given equation can be written as  $\frac{1 - \cos 2x}{2} + \frac{1 - \cos 4x}{2} = 1$

$$\Rightarrow \cos 2x + \cos 4x = 0 \Rightarrow 2 \cos 3x \cos x = 0$$

$$\Rightarrow \cos 3x = 0 \text{ i.e., } 3x = (2n+1)\frac{\pi}{2} \Rightarrow x = (2n+1)\frac{\pi}{6}, \text{ where } n \in \mathbb{Z}$$

or  $\cos x = 0$  i.e.,  $x = (2m + 1) \frac{\pi}{2}$ , where  $m \in \mathbb{Z}$

Since all the solutions of  $x = (2m + 1) \frac{\pi}{2}$  are included in  $x = (2n + 1) \frac{\pi}{6}$

So, the required solution can be written as  $x = (2n + 1) \frac{\pi}{6}$ ;  $n \in \mathbb{Z}$

**ILLUSTRATION 13:** Solve  $\cos x - 2\sin^2 x/2 = 0$

**SOLUTION:** The given equation can be written as  $\cos x - (1 - \cos x) = 0$

$$\Rightarrow 2 \cos x = 1 \Rightarrow \cos x = 1/2 = \cos \pi/3$$

$$\Rightarrow x = 2n\pi \pm \pi/3; n \in \mathbb{Z}$$

**ILLUSTRATION 14:** Solve  $\sin x + \sin 3x = 2\cos x$

**SOLUTION:** The equation can be written as  $2 \sin 2x \cos x = 2\cos x$

i.e.,  $2 \cos x (\sin 2x - 1) = 0$  so either  $\cos x = 0$  or  $\sin 2x = 1$

The equation  $\cos x = 0$  gives  $x = (2n + 1)\pi/2$ ,  $n \in \mathbb{Z}$

The equation  $\sin 2x = 1$  gives  $2x = (4n + 1)\pi/2$ ,  $n \in \mathbb{Z}$

i.e.,  $x = (4n + 1) \frac{\pi}{4}$ ,  $n \in \mathbb{Z}$

Hence the solution set is  $\left\{ (4n + 1) \frac{\pi}{4} : n \in \mathbb{Z} \right\} \cup \left\{ (2n + 1) \frac{\pi}{2} : n \in \mathbb{Z} \right\}$

## TEXTUAL EXERCISE-2 (SUBJECTIVE)

1. Solve the following equations for  $\theta$ .

(a)  $\sin(m + n)\theta + \sin(m - n)\theta = \sin m\theta$

(b)  $\cos 3\theta = \cos^3 \theta$

2. Solve the following equations for  $\theta$ .

(a)  $\cos \theta + \cos 7\theta = \cos 4\theta$

(b)  $\cos \theta + \cos 3\theta = 2\cos 2\theta$

3. Solve the following equations for  $\theta$ .

$$\cos \theta + \cos 2\theta + \cos 3\theta = 0$$

4. Solve the following equation for  $\theta$ .

$$\cos(3\theta + \alpha) \cos(3\theta - \alpha) + \cos(5\theta + \alpha) \cos(5\theta - \alpha) = \cos 2\alpha$$

5. Solve the following equation for  $\theta$ :  $\sin(3\theta + \alpha)$

$$\sin(3\theta - \alpha) + \sin(\alpha + \theta) - \sin(\theta - \alpha) = \cos 2\alpha$$

## Answer Keys

1. (a)  $k\pi/m$ ;  $2k\pi/n \pm \pi/3n$ ,  $k, n \in \mathbb{Z}$  (b)  $n\pi/2$ ;  $n \in \mathbb{Z}$

2. (a)  $\left(2n \pm \frac{1}{3}\right) \frac{\pi}{3}$ ;  $n \in \mathbb{Z}$  (b)  $\left(n + \frac{1}{2}\right) \frac{\pi}{2}$  or  $2n\pi$ ;  $n \in \mathbb{Z}$  3.  $\left(n + \frac{1}{2}\right) \frac{\pi}{2}$  or  $\left(2n\pi \pm \frac{2\pi}{3}\right)$ ;  $n \in \mathbb{Z}$

4.  $\left(n + \frac{1}{2}\right) \frac{\pi}{8}$  or  $\left(n + \frac{1}{2}\right) \frac{\pi}{2}$ ;  $n \in \mathbb{Z}$

5.  $\theta = \frac{n\pi}{4} + \frac{\pi}{8}$  or  $\theta = \frac{n\pi}{2} - \frac{\pi}{4}$ ;  $n \in \mathbb{Z}$

## General solution of equation $\tan \theta = k$

**Theorem 1:**  $\tan \theta = 0 \Leftrightarrow \theta = n\pi$ , where  $n \in \mathbb{Z}$

**Proof:** We know that  $\tan \theta = 0$  for all integral multiple of  $\pi$ .

$$\begin{aligned} \therefore \tan \theta &= 0 \\ \Leftrightarrow \theta &= 0, \pm\pi, \pm2\pi, \pm3\pi, \dots \\ \Leftrightarrow \theta &= n\pi, \quad n \in \mathbb{Z} \\ \therefore \tan \theta &= 0 \\ \Leftrightarrow \theta &= n\pi, \quad n \in \mathbb{Z} \end{aligned}$$

**Theorem 2:** Let  $k$  be any real number and  $\alpha$  be a particular solution of the equation  $\tan \theta = k$ . Then the general solution of equation  $\tan \theta = \tan \alpha$  is  $\theta = n\pi + \alpha$ ,  $n \in \mathbb{Z}$

$$\in \mathbb{Z} \text{ where } \alpha \in \left(-\frac{\pi}{2}, \frac{\pi}{2}\right).$$

**Proof:** We have,  $\tan \theta = \tan \alpha$ , where  $\alpha \in \left(-\frac{\pi}{2}, \frac{\pi}{2}\right)$

$$\Leftrightarrow \frac{\sin \theta}{\cos \theta} = \frac{\sin \alpha}{\cos \alpha}$$

$$\Leftrightarrow \sin \theta \cos \alpha - \cos \theta \sin \alpha = 0 \Leftrightarrow \sin(\theta - \alpha) = 0$$

$$\Leftrightarrow \theta - \alpha = n\pi, \quad n \in \mathbb{Z} \Leftrightarrow \theta = n\pi + \alpha, \quad n \in \mathbb{Z}$$

$$\Leftrightarrow \theta = n\pi + \alpha, \text{ where } \alpha \in \left(-\frac{\pi}{2}, \frac{\pi}{2}\right)$$

### Graphically

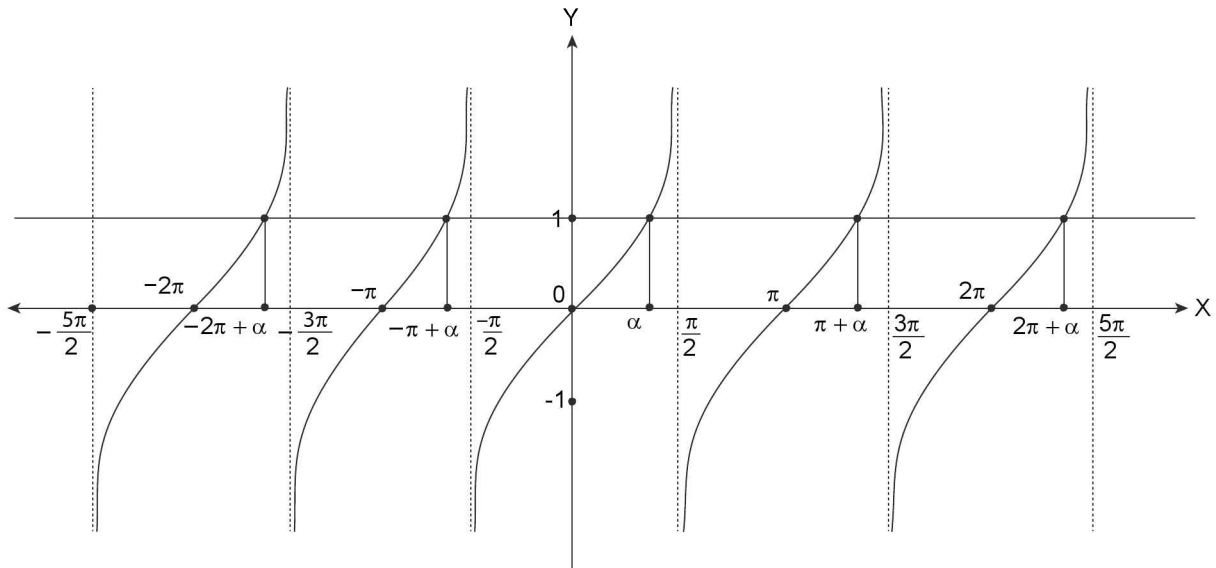

FIGURE 2.6

It is also clear from the graph that solutions are of the type  $n\pi + \alpha$ .

### REMARKS

Similarly, the equation of the form  $\cot \theta = k$ ,  $\sec \theta = k$ ,  $\operatorname{cosec} \theta = k$  can be respectively transformed into the forms  $\tan \theta = 1/k$  ( $k \neq 0$ ),  $\cos \theta = 1/k$ ,  $\sin \theta = 1/k$  which can be solved as mentioned above.

**ILLUSTRATION 15:** Solve the equation  $\tan^2 \theta - (1 + \sqrt{3}) \tan \theta + \sqrt{3} = 0$

**SOLUTION:** Factorizing the given equation  $(\tan \theta - 1)(\tan \theta - \sqrt{3}) = 0$

$$\Rightarrow \tan \theta = 1 \text{ or } \tan \theta = \sqrt{3} \Rightarrow \tan \theta = \tan \pi/4 \text{ or } \tan \theta = \tan(\pi/3) \Rightarrow \theta = n\pi + \pi/4 \text{ or } \theta = n\pi + \pi/3$$

union of the above two sets of solution is general solution.

**ILLUSTRATION 16:** Solve the equation  $\tan(\pi/4 - x) + \tan(\pi/4 + x) = 4$ .

**SOLUTION:** 
$$\frac{1 - \tan x}{1 + \tan x} + \frac{1 + \tan x}{1 - \tan x} = 4$$

$$\Rightarrow \frac{(1 + \tan x)^2 + (1 - \tan x)^2}{1 - \tan^2 x} = 4$$

$$\Rightarrow 2(1 + \tan^2 x) = 4(1 - \tan^2 x)$$

$$\Rightarrow 3 \tan^2 x = 1 \Rightarrow \tan^2 x = 1/3$$

$$\Rightarrow \tan x = \pm 1/\sqrt{3} \quad \text{or} \quad \tan x = \tan\left(\pm \frac{\pi}{6}\right)$$

$$\Rightarrow x = n\pi + \pi/6 \quad \text{or} \quad x = n\pi - \pi/6; n \in \mathbb{Z}$$

So, solution is  $x = n\pi \pm \pi/6; n \in \mathbb{Z}$

**ILLUSTRATION 17:** Solve the equation  $\tan \theta + \tan 2\theta + \tan \theta \cdot \tan 2\theta = 1$

**SOLUTION:** We rewrite the equation as;  $\tan \theta + \tan 2\theta = 1 - \tan \theta \cdot \tan 2\theta$

$$\Rightarrow \frac{\tan \theta + \tan 2\theta}{1 - \tan \theta \cdot \tan 2\theta} = 1 \Rightarrow \tan 3\theta = 1 = \tan(\pi/4)$$

$$\Rightarrow 3\theta = n\pi + \pi/4 \Rightarrow \theta = \frac{n\pi}{3} + \frac{\pi}{12}$$

**ILLUSTRATION 18:** Solve  $\sec x - 1 = (\sqrt{2} - 1) \tan x$  for real values of  $x$ .

**SOLUTION:** Given equation is  $\sec x - 1 = (\sqrt{2} - 1) \tan x$

As we know the relation  $\sec^2 \theta = \tan^2 \theta + 1$ . It can be exploit by squaring both sides of the given equation in an appropriate manner

$$\Rightarrow \sec x = (\sqrt{2} - 1) \tan x + 1$$

$$\Rightarrow \sec^2 x = (\sqrt{2} - 1)^2 \tan^2 x + 1 + 2(\sqrt{2} - 1) \tan x$$

$$\Rightarrow 1 + \tan^2 x = (2 + 1 - 2\sqrt{2}) \tan^2 x + 1 + 2(\sqrt{2} - 1) \tan x$$

$$\Rightarrow 2(1 - \sqrt{2}) \tan x (\tan x - 1) = 0$$

$$\Rightarrow \tan x = 0 \Rightarrow x = n\pi$$

$$\text{or } \tan x - 1 = 0 \Rightarrow x = n\pi + \pi/4 \quad \Rightarrow \quad x = n\pi \text{ or } n\pi + \pi/4; n \in \mathbb{Z}$$

**Aliter:** Let  $\sec x - 1 = (\sqrt{2} - 1) \tan x \Rightarrow 1 - \cos x = (\sqrt{2} - 1) \sin x$

$$\Rightarrow 2 \sin^2 \frac{x}{2} - (\sqrt{2} - 1) \cdot 2 \sin \frac{x}{2} \cdot \cos \frac{x}{2} = 0 \Rightarrow 2 \sin \frac{x}{2} \left\{ \sin \frac{x}{2} - (\sqrt{2} - 1) \cos \frac{x}{2} \right\} = 0$$

$$\Rightarrow \sin \frac{x}{2} \left\{ \sin \frac{x}{2} - (\sqrt{2} - 1) \cos \frac{x}{2} \right\} = 0 \Rightarrow \sin \frac{x}{2} = 0 \text{ or } \tan \frac{x}{2} = (\sqrt{2} - 1) = \tan \frac{\pi}{8}$$

$$\Rightarrow \frac{x}{2} = n\pi \text{ or } \frac{x}{2} = n\pi + \frac{\pi}{8} \Rightarrow x = 2n\pi, 2n\pi + \frac{\pi}{4}$$

**Note:**

It is important to note here that all the above are not the solutions of the original equation but of its squared version. Squaring many times brings some extra solutions. So we must check which of the solutions satisfy the original equation.

**Check:**

$$(i) \text{ for } x = n\pi \Rightarrow \sec(n\pi) - 1 = (\sqrt{2} - 1) \tan(n\pi)$$

$$\Rightarrow (-1)^n - 1 = 0$$

It is true only when  $n$  is even. Hence for odd  $n$  an extra solution has been obtained which does not satisfy the original equation. So, it should be excluded.

$$\Rightarrow \text{only } \theta = 2k\pi \text{ is a solution for } k \in \mathbb{Z}$$

$$(ii) \text{ for } x = n\pi + \pi/4 \Rightarrow \sec(n\pi + \pi/4) - 1 = (\sqrt{2} - 1) \tan(n\pi + \pi/4)$$

$$\Rightarrow \sqrt{2} - 1 - (\sqrt{2} - 1) \Rightarrow (-1)^n \sqrt{2} - 1 = (\sqrt{2} - 1). \text{ Which is true only for even } n.$$

Hence  $x = 2n\pi + \pi/4$  is a solution.

$$\text{Hence the general solution is } x = (2m\pi), \left(2n\pi + \frac{\pi}{4}\right); \text{ where } n, m \in \mathbb{Z}$$

**TEXTUAL EXERCISE-3 (SUBJECTIVE)**

1. Solve the following equations for  $\theta$ .

(a)  $\tan 5\theta + \cot 2\theta = 0$

(b)  $3 \tan(\theta - 15^\circ) = \tan(\theta + 15^\circ)$

2. Solve the equation  $\sin 3x = \cos x$ .

3. Solve the following equations for  $\theta$ .

(a)  $\cos \theta = 1 + \cot \theta$       (b)  $\cot \theta - \tan \theta = 2$

(c)  $\tan \theta + \sec \theta = \sqrt{3}$

4. Solve the following equation for  $\theta$ .

$$\tan \theta + \tan 2\theta + \tan 3\theta = 0.$$

**Answer Keys**

1. (a)  $\theta \in (2n+1)\frac{\pi}{6}; n \in \mathbb{Z} \sim \left\{ \frac{3k-1}{2}, k \in \mathbb{Z} \right\}$       (b)  $n\pi + \frac{\pi}{4}; n \in \mathbb{Z}$       2.  $x = n\pi + \frac{\pi}{4}$  or  $2n\pi + \frac{\pi}{8}$

3. (a)  $\theta = \frac{n\pi + (-1)^n \alpha}{2}; n \in \mathbb{Z}; \sin \alpha = 2 - 2\sqrt{2}$       (b)  $\left(n + \frac{1}{4}\right)\frac{\pi}{2}; n \in \mathbb{Z}$       (c)  $2n\pi + \pi/6; n \in \mathbb{Z}$

4.  $\theta = n\pi; n \in \mathbb{Z}$  or  $\theta = n\pi \pm \frac{\pi}{3}; n \in \mathbb{Z}$  or  $\theta = n\pi \pm \tan^{-1}\left(\frac{1}{\sqrt{2}}\right); n \in \mathbb{Z}$

**General solution of equations  $\sin^2 \theta = k$ ,  $\cos^2 \theta = k$ ,  $\tan^2 \theta = k$** 

$$\sin^2 \theta = \sin^2 \alpha, \cos^2 \theta = \cos^2 \alpha, \tan^2 \theta = \tan^2 \alpha \Leftrightarrow \theta = n\pi \pm \alpha$$

(i)  $\sin^2 \theta = \sin^2 \alpha$

$$\Leftrightarrow \frac{1 - \cos 2\theta}{2} = \frac{1 - \cos 2\alpha}{2}$$

$$\Leftrightarrow \cos 2\theta = \cos 2\alpha$$

$$\Leftrightarrow 2\theta = 2n\pi \pm 2\alpha, n \in \mathbb{Z}$$

$$\Leftrightarrow \theta = n\pi \pm \alpha, n \in \mathbb{Z}$$

(ii)  $\cos^2 \theta = \cos^2 \alpha$

$$\Leftrightarrow \frac{1 + \cos 2\theta}{2} = \frac{1 + \cos 2\alpha}{2}$$

$$\Leftrightarrow \cos 2\theta = \cos 2\alpha$$

$$\Leftrightarrow 2\theta = 2n\pi \pm 2\alpha, n \in \mathbb{Z}$$

$$\Leftrightarrow \theta = n\pi \pm \alpha, n \in \mathbb{Z}$$

(iii)  $\tan^2 \theta = \tan^2 \alpha$

$$\Leftrightarrow \frac{1 - \tan^2 \theta}{1 + \tan^2 \theta} = \frac{1 - \tan^2 \alpha}{1 + \tan^2 \alpha}$$

(applying componendo and dividendo)

$$\Leftrightarrow \cos 2\theta = \cos 2\alpha$$

$$\Leftrightarrow 2\theta = 2n\pi \pm 2\alpha, n \in \mathbb{Z}$$

$$\Leftrightarrow \theta = n\pi \pm \alpha, n \in \mathbb{Z}$$



2.12 ➤ Trigonometry

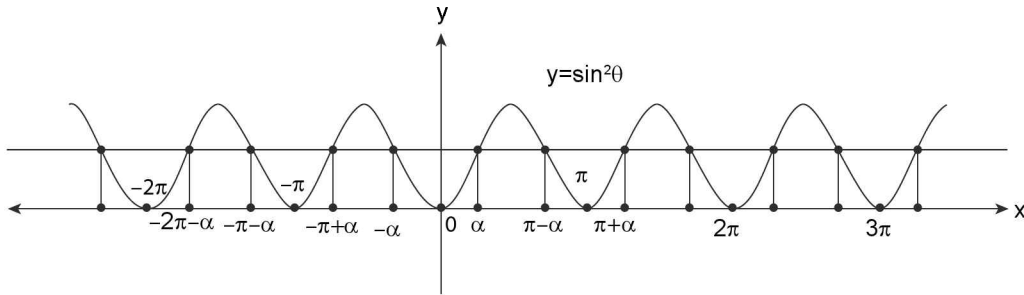

FIGURE 2.7

Table 2.2 Results at a glance (In results given below  $n \in \mathbb{Z}$ )

S.No.	Equation	General Solution	S.No.	Equation	General Solution
1.	$\sin \theta = 0$	$\theta = n\pi$	2.	$\cos \theta = 0$	$\theta = (2n + 1) \pi/2$
3.	$\tan \theta = 0$	$\theta = n\pi$	4.	$\sin \theta = 1$	$\theta = (4n + 1) \pi/2$
5.	$\cos \theta = 1$	$\theta = 2n \pi.$	6.	$\sin \theta = -1$	$\theta = (4n - 1) \pi/2$
7.	$\cos \theta = -1$	$\theta = (2n + 1) \pi.$	8.	$\tan \theta = \pm 1$	$\theta = n \pi \pm \pi/4$
9.	$\sin \theta = \sin \alpha$	$\theta = n \pi + (-1)^n \alpha$	10.	$\cos \theta = \cos \alpha$	$\theta = 2n \pi \pm \alpha,$
11.	$\tan \theta = \tan \alpha$	$\theta = n \pi + \alpha$	12.	$\sin^2 \theta = \sin^2 \alpha$	$\theta = n \pi \pm \alpha$
13.	$\cos^2 \theta = \cos^2 \alpha$	$\theta = n \pi \pm \alpha$	14.	$\tan^2 \theta = \tan^2 \alpha$	$\theta = n \pi \pm \alpha.$

NOTES

1.  $\alpha$  is generally used to denote the principal value of the angle. (i.e., numerically least angle)
2. Untill and otherwise every where in this chapter 'n' is taken as an integer.
3. The general solution should be given unless the solution is required in a specified interval or range.

**ILLUSTRATION 19:** Solve the equation  $7 \tan^2 \theta - 9 = 3 \sec^2 \theta$ .

**SOLUTION:** Given  $7 \tan^2 \theta - 9 = 3 \sec^2 \theta$ .

$$\text{or, } 7 \tan^2 \theta - 9 = 3(1 + \tan^2 \theta) \text{ or, } 4 \tan^2 \theta = 12$$

$$\text{or, } \tan^2 \theta = \left( \tan \frac{\pi}{3} \right)^2$$

$$\Rightarrow \theta = n\pi \pm \frac{\pi}{3} \quad n \in \mathbb{Z}$$

**ILLUSTRATION 20:** Solve  $7 \cos^2 \theta + 3 \sin^2 \theta = 4$ .

**SOLUTION:** Given  $7 \cos^2 \theta + 3 \sin^2 \theta = 4$  or,  $7 \cos^2 \theta + 3(1 - \cos^2 \theta) = 4$ .

$$\text{or, } 4 \cos^2 \theta = 1 \quad \therefore \cos^2 \theta = 1/4 = \cos^2 \pi/3$$

$$\Rightarrow \theta = n\pi \pm \pi/3 \text{ where } n \in \mathbb{Z}.$$

**TEXTUAL EXERCISE-4 (SUBJECTIVE)**

1. Solve the equation  $\tan^2 x + \cot^2 x = 2$ .
2. Solve the equation  $\tan^2 x = 3 \operatorname{cosec}^2 x - 1$ .
3. Solve the equation  $2 \sin^2 x + \sin^2 2x = 2$ .
4. Solve the equation  $2 + 7 \tan^2 \theta = 3.25 \sec^2 \theta$ .
5. Solve the equation  $\cos 2\theta = \cos^2 \theta$ .
6.  $\sin^2 n\theta - \sin^2(n-1)\theta = \sin^2 \theta$ .

**Answer Keys**

1.  $n\pi \pm \pi/4; n \in \mathbb{Z}$
2.  $n\pi \pm \pi/3; n \in \mathbb{Z}$
3.  $(2n+1) \frac{\pi}{2}; n\pi \pm \pi/4; n \in \mathbb{Z}$
4.  $n\pi \pm \pi/6; n \in \mathbb{Z}$
5.  $n\pi, n \in \mathbb{Z}$
6.  $m\pi$  or  $\frac{m\pi}{n-1}$  or  $\left(m + \frac{1}{2}\right) \frac{\pi}{n}; m \in \mathbb{Z}$

**EQUIVALENT EQUATIONS**

**Definition:** Two equations are called equivalent if they have same set of solutions. Therefore  $f(x) = 0$  is equivalent to  $g(x) = 0$ , iff same set of values of  $x$  satisfy both the equations.

**For example**

- (i)  $\sin x = 0$  and  $\tan x = 0$  both are equivalent equation as  $\theta = n\pi$  is the solution of both the equations.

(ii)  $\sin^2 \theta = 1$  and  $\cos \theta = 0$ , these are equivalent equation.

(iii)  $\sin \theta = \frac{1}{\sqrt{2}}$  and  $\sin^2 \theta = \frac{1}{2}$ , these are not equivalent equations because the solution set of the two equations is not the same.

(iv)  $\sin^2 \theta = \frac{1}{2}$  and  $\cos^2 \theta = \frac{1}{2}$  are equivalent equations.

**NOTES**

1. While solving an equation, the equation can be replaced only by its equivalent equations.
2. No such transformation should be done in which domain of equation expands because expansion of domain may leads to extraneous roots.
3. No such transformation should be carried out in which the domain of equation contracts because domain contraction may result into loss of roots.

**IMPORTANT POINTS TO REMEMBER****Caution: 1**

1. At times you may find that your answer has different format than that in the book in their notations. This may be due to the different methods of solving the same problem. To deal with such situation, you must check their authenticity. This will ensure that your answer is correct.

e.g., when  $\cos \theta = 0 \Rightarrow \theta = (2n+1) \frac{\pi}{2}$  or

$$\theta = (2n \pm 1) \frac{\pi}{2}$$

or  $\theta = (4n \pm 1) \frac{\pi}{2}$  but all are equally true.

2. While solving trigonometric equations, you may get same set of solution repeated in your answer. It is necessary for you to exclude these repetitions e.g.,

2.14 > Trigonometry

$$\left(n\pi + \frac{\pi}{2}\right) \cup \left(\frac{k\pi}{5} + \frac{\pi}{10}\right), n, k \in \mathbb{Z}, \text{ the set } n\pi + \frac{\pi}{2}$$

forms a part of the second set of solution (you can check by putting  $k = 5m + 2$ ;  $m \in \mathbb{Z}$ ). Hence the final answer should be  $\frac{k\pi}{5} + \frac{\pi}{10}, k \in \mathbb{Z}$

3. Sometimes the two solution set consist partly of common values. In all such cases the common part must be presented only once. This is done because the general solution is set of solutions which is obtained by taking union of such sets. All the elements in a set must be distinct, so repetition of solution must be avoided.

**Caution: 2**

Following tips and steps will help you to systematically solve the trigonometric equations.

1. Try to reduce equation in terms of one single trigonometric ratio preferably  $\sin\theta$  or  $\cos\theta$ .  
If we have choice to convert a problem in sine or cosine then cosine form is convenient compared to sine form. This is because in general solution of sine, we will have to deal with  $(-1)^n$  which is inconvenient compared to the dealing of  $\pm$  obtained in cosine form.
2. Factorize the polynomial in terms of these trigonometric ratios (sine, cosine) ratio
3. For Left Hand Side to be zero, solve for each factor. And write down general solution, for each factor based on the standard results, that are derived in earlier articles.

$$\text{e.g., } \sin\theta - \lambda_1 = 0 \Rightarrow \theta = n\pi + (-1)^n \sin^{-1} \lambda_1$$

$$\cos\theta - \lambda_2 = 0 \Rightarrow \theta = 2n\pi \pm \cos^{-1} \lambda_2$$

Make sure that  $\lambda_1$  and  $\lambda_2 \in [-1, 1]$  rather than blindly writing it, otherwise the solution will be absurd.

**Caution: 3 (Domain of Equation)**

We already know that domain of a function is set of the values of independent variable for which that function is defined, and domain of an equation is defined as a common interval for unknown angle in which all the trigonometric functions used in equation are individually defined and equation as a whole and part remains defined.

“Domain of equation should not change. If it changes, necessary correction must be made”.

**Caution: 4 (Root Loss in an Equation)**

While solving an equation in  $\theta$  if we get some values of  $\theta$  and all of them satisfy the equation and there exist another value of  $\theta$  which satisfies the equation but is not present in our solution, then this value is clearly a root of the equation but is missing in our answer. Such value will be called as ‘lost root’. Root loss while solving the equation means that we have missed out some solutions due to some algebraic operations.

If in any process there is a loss of roots, then that process is defective, because for general solution all possible values satisfying the equation must be obtained. Thus for complete solution there should be no loss of root.

**ILLUSTRATION 21:** Solve the equation  $\sin\theta - 2\cos\theta = 2$

**SOLUTION:** Given the equation  $\sin\theta - 2\cos\theta = 2$  ... (i)

Converting  $\sin\theta$  and  $\cos\theta$  into function of  $\tan\theta/2$ , we obtain

$$\frac{2 \tan \theta/2}{1 + \tan^2 \theta/2} - \frac{2(1 - \tan^2 \theta/2)}{1 + \tan^2 \theta/2} = 2 \Rightarrow \tan \frac{\theta}{2} - 1 + \tan^2 \frac{\theta}{2} = 1 + \tan^2 \frac{\theta}{2}$$

$$\text{or, } \tan \frac{\theta}{2} = 2 = \tan \beta \Rightarrow \theta = 2n\pi + 2 \tan^{-1} 2; n \in \mathbb{Z}$$

Now, we claim that  $\theta = (2n+1)\pi$  is also a solution of this equation.

To verify it we put  $\theta = \pi$  (i.e when  $n = 0$ ) in original equation (i) we get

$$\sin\pi - 2 \cos \pi = 2 \text{ or } 0 - 2(-1) = 2$$

Thus clearly, the equation is satisfied. Similarly, for other values of  $n$  also the equation remains satisfied for  $\theta = (2n + 1)\pi$ . So our claim is valid.

Concluding, we can say that  $\theta = (2n + 1)\pi$  is a root of the equation but it is not present in our solution. i.e., there has been a loss of roots in the process of solution implying that conversion of  $\sin\theta$  and  $\cos\theta$  in  $\tan \theta/2$  for solution of an equation may cause root loss.

The question is why there has been loss of root? In the original equation,  $\theta$  is not restricted. The only restriction is that it must satisfy the equation. But on transforming  $\sin\theta$  and  $\cos\theta$  in  $\tan \theta/2$ , a restriction has automatically crept in. The restriction is  $\tan \theta/2$  should be defined.

i.e.,  $\frac{\theta}{2}$  should not be odd multiple of  $\frac{\pi}{2}$ .

or,  $\frac{\theta}{2} \neq (2n + 1) \frac{\pi}{2}$  or,  $\theta \neq (2n + 1)\pi$

That is why it is missing in the answer. Loss of root occurs due to change of domain of equation. So, we conclude that domain should not change while solving equation.

### Caution: 5 (Extraneous Roots)

While solving the trigonometric equations, if a root obtained does not satisfy the equation, then it is called an extraneous

root. e.g., to solve the equation  $\tan \theta = 1 \Rightarrow \tan^2 \theta = 1 \Rightarrow \theta = n\pi \pm \pi/4$

But the solutions  $n\pi - \pi/4$  do not satisfy the equation  $\tan \theta = 1$  and thus called as “extraneous roots”.

**ILLUSTRATION 22:** Solve the equation  $\sin\theta - \cos\theta = 1$

**SOLUTION:** We can use various methods to solve this equation. One of them is squaring both sides:

The given equation is  $\sin\theta - \cos\theta = 1$  ... (i)

By squaring, we get  $\sin^2\theta + \cos^2\theta - 2\sin\theta \cos\theta = 1$  or,  $1 - \sin 2\theta = 1$

or  $\sin 2\theta = 0 \Rightarrow 2\theta = n\pi$

$\therefore \theta = n\pi/2$  where  $n \in \mathbb{Z}$ .

If  $\theta = 0$  (i.e., for  $n = 0$ ) substituting in the equation (i)

we get LHS =  $0 - 1 = -1 \neq$  RHS

Therefore  $\theta = 0$  though obtained in the process of solution, does not satisfy the equation. So, it is an extraneous root. A close observation of the solution  $\theta = n\pi/2$  will indicate that a number of extraneous roots are present in this answer. To find the reason for presence of extraneous root, let us consider the equation  $\sin\theta - \cos\theta = -1$  ... (ii)

Squaring we get, the equation  $1 - \sin 2\theta = 1$  whose solution is:

$\Rightarrow \sin 2\theta = 0 \Rightarrow 2\theta = n\pi$

$\therefore \theta = n\pi/2$  which is same as when the equation was  $\sin\theta - \cos\theta = 1$

Put  $\theta = 0$  (when  $n = 0$ ) in (ii) we get L.H.S. =  $0 - 1 = -1 =$  R.H.S

$\Rightarrow$  equation is satisfied. Thus,  $\theta = 0$  is actually the solution of equation (ii). Since square of  $+1$  and  $-1$  is the same, the equation after squaring contains the roots of both the equations (i) and (ii). That is why we got extraneous roots. Thus we can conclude that

**‘Squaring should be avoided as far as possible. If squaring is done, check for the extraneous roots’.**

**ILLUSTRATION 23:** Solve the equation  $-\tan\theta + \sec\theta = \sqrt{3}$ .

**SOLUTION:** Given equation is  $-\tan\theta + \sec\theta = \sqrt{3}$  ... (i)

$$\text{then } -\frac{\sin\theta}{\cos\theta} + \frac{1}{\cos\theta} = \sqrt{3} \quad \dots \text{(ii)} \quad \Rightarrow \quad \sqrt{3}\cos\theta + \sin\theta = 1$$

dividing both sides by 2, we get

$$\Rightarrow \frac{\sqrt{3}}{2}\cos\theta + \frac{1}{2}\sin\theta = \frac{1}{2} \Rightarrow \cos\theta \cdot \cos\frac{\pi}{6} + \sin\theta \cdot \sin\frac{\pi}{6} = \cos\frac{\pi}{3}$$

$$\Rightarrow \cos\left(\theta - \frac{\pi}{6}\right) = \cos\frac{\pi}{3} \Rightarrow \theta - \frac{\pi}{6} = 2n\pi \pm \frac{\pi}{3}$$

$$\text{Taking positive sign, } \theta - \frac{\pi}{6} = 2n\pi + \frac{\pi}{3} \Rightarrow \theta = 2n\pi + \frac{\pi}{2}$$

$$\Rightarrow \theta = (4n+1)\frac{\pi}{2}. \text{ Taking negative sign } \theta - \frac{\pi}{6} = 2n\pi - \frac{\pi}{3} \Rightarrow \theta = 2n\pi - \frac{\pi}{6}$$

Let us verify the solution thus obtained.

For the solution to be correct  $\cos\theta \neq 0$  otherwise terms in (i) will not be defined.

Therefore  $\theta$  should not be odd multiple of  $\pi/2$ .

$$\Rightarrow \theta \neq (4n+1)\frac{\pi}{2} \quad [\because 4n \text{ is even and } 4n+1 \text{ is odd}]$$

Hence the solution will be  $\theta = 2n\pi - \frac{\pi}{6}$  only, where  $n \in \mathbb{Z}$

From above discussion we conclude that:

**We should check that denominator is not zero (at any stage of the solution) for any value of  $\theta$  which is contained in the answer.**

**ILLUSTRATION 24:** Solve the equation  $\tan 5\theta = \tan 3\theta$

**SOLUTION:** Now  $\tan 5\theta = \tan 3\theta \Rightarrow 5\theta = n\pi + 3\theta$

$$\text{or, } 2\theta = n\pi \Rightarrow \theta = \frac{n\pi}{2}, \text{ where } n \in \mathbb{Z}$$

putting  $n = 0$ , we get  $\theta = 0$  for which original equation is satisfied

$$\text{putting } n = 1, \theta = \pi/2 \text{ equation becomes } \tan\frac{5\pi}{2} = \tan\frac{3\pi}{2}$$

Equation is not defined for odd multiple of  $\pi/2$

hence we conclude that  $\theta = n\pi$ , where  $n \in \mathbb{Z}$

**ILLUSTRATION 25:** Find the set of values of  $x$  for which  $\frac{\tan 3x - \tan 2x}{1 + \tan 3x \cdot \tan 2x} = 1$

**SOLUTION:** Given equation is  $\frac{\tan 3x - \tan 2x}{1 + \tan 3x \cdot \tan 2x} = 1$

$$\Rightarrow \tan(3x - 2x) = 1 \Rightarrow \tan x = 1$$

$$\Rightarrow \tan x = \tan(\pi/4) \Rightarrow x = n\pi + \pi/4$$

But for this value of  $x$ ,  $\tan 2x = \tan(2n\pi + \pi/2) = \infty$ ,

which does not satisfy the given equation as it reduces the LHS expression to indeterminate form. Hence the solution set for  $x$  is null set ( $\phi$ ).

## SOURCES OF EXTRANEIOUS ROOT AND LOSS OF ROOT

Analysing the previous illustrations, we can conclude that Extraneous roots normally occur because of either extension of domain or squaring or raising the power of both sides of equation, while the loss of root is because of restriction of domain or cancellation of terms containing unknown on both sides of equation which are in product. To avoid the occurrence of the above two; following points must be taken care of:

1. We should not blindly cancel like factors on two sides because this term may also contain

additional roots. Cancellation may cause root loss.

2. Avoid squaring as far as possible while solving the equation because by squaring we may get invite extra roots. If squaring is unavoidable then do check for extraneous roots after solving finally.
3. The answer should not contain such values of  $\theta$  which make any of the terms undefined or infinite.
4. Domain should not change. In case of the change of domain, necessary corrections must be applied.
5. Check that denominator is not zero at any stage while solving the equation.

**ILLUSTRATION 26:** Find the number of solutions of  $\tan x + \sec x = 2\cos x$  in  $[0, 2\pi]$ .

**SOLUTION:** Here, we have  $\tan x + \sec x = 2\cos x$  .....(i)

$$\Rightarrow \sin x + 1 = 2\cos^2 x \Rightarrow 2\sin^2 x + \sin x - 1 = 0 \Rightarrow \sin x = 1/2, -1$$

But  $\sin x = -1 \Rightarrow x = \frac{3\pi}{2}$  which does not satisfy the parent equation (i)

$$\text{Thus } \sin x = \frac{1}{2} \Rightarrow x = \frac{\pi}{6}, \frac{5\pi}{6}$$

$\Rightarrow$  number of solutions of  $\tan x + \sec x = 2\cos x$  is 2.

**ILLUSTRATION 27:** Solve  $\sin x = 0$  and  $\frac{\sin x}{\cos(x/2)\cos(3x/2)} = 0$  and show that their solutions are different.

**SOLUTION:** We have,  $\sin x = 0 \Rightarrow x = n\pi$  i.e.,  $x = 0, \pi, 2\pi, 3\pi,$  .....(i)

Where as  $\frac{\sin x}{\cos(x/2)\cos(3x/2)} = 0$  where  $\cos x/2 \neq 0$  and  $\cos 3x/2 \neq 0$

$$\Rightarrow \frac{x}{2} \neq \frac{\pi}{2}, \frac{3\pi}{2}, \frac{5\pi}{2}, \dots \text{ and } \frac{3x}{2} \neq \frac{\pi}{2}, \frac{3\pi}{2}, \frac{5\pi}{2}, \dots$$

$$\Rightarrow x \neq \pi, 3\pi, 5\pi, \dots \text{ and } x \neq \frac{\pi}{3}, \pi, \frac{5\pi}{3}, \dots \text{ .....(ii)}$$

$$\text{But } \frac{\sin x}{\cos x/2 \cos 3x/2} = 0 \Rightarrow \sin x = 0$$

$$\Rightarrow x = \pi, 2\pi, 3\pi, 4\pi, \dots \text{ .....(iii)}$$

$$\text{From (ii) and (iii), we get } x = 2\pi, 4\pi, 6\pi, \dots \text{ .....(iv)}$$

i.e., we observe from (i) and (iv) that the two equations are not equivalent. Since, some solutions of the first do not satisfy the second equation.

**ILLUSTRATION 28:** Solve  $\cot \theta = \sin 2\theta$  by substituting  $\sin 2\theta = \frac{2 \tan \theta}{1 + \tan^2 \theta}$  and again by substituting  $\sin 2\theta = 2\sin \theta \cos \theta$  and check whether the two answers tally or not.

**SOLUTION: First Method:** Put  $\sin 2\theta = \frac{2 \tan \theta}{1 + \tan^2 \theta}$ ; in  $\cot \theta = \sin 2\theta$

$$\Rightarrow \cot \theta = \frac{2 \tan \theta}{1 + \tan^2 \theta} \Rightarrow \frac{1}{\tan \theta} = \frac{2 \tan \theta}{1 + \tan^2 \theta}$$

$$\Rightarrow 2 \tan^2 \theta = 1 + \tan^2 \theta \Rightarrow \tan^2 \theta = 1$$

$$\Rightarrow \tan^2 \theta = (1)^2 = \tan^2(\pi/4) \Rightarrow \theta = n\pi \pm \frac{\pi}{4} \quad \dots(i)$$

**Second Method:** Put  $\sin 2\theta = 2 \sin \theta \cos \theta$

$$\therefore \cot \theta = \sin 2\theta$$

$$\Rightarrow \frac{\cos \theta}{\sin \theta} = 2 \sin \theta \cos \theta \Rightarrow \cos \theta = 2 \sin^2 \theta \cos \theta$$

$$\Rightarrow \cos \theta(1 - 2 \sin^2 \theta) = 0 \Rightarrow \cos \theta = 0$$

$$\text{or } \sin^2 \theta = \frac{1}{2} = \left(\frac{1}{\sqrt{2}}\right)^2 = \sin^2 \pi/4$$

$$\Rightarrow \theta = (2n+1)\frac{\pi}{2} \text{ or } \theta = n\pi \pm \frac{\pi}{4} \quad \dots(ii)$$

From (i) and (ii) it is clear first method gives less number of roots than the second method, and the cause of root loss is restriction of domain.

## TEXTUAL EXERCISE-5 (SUBJECTIVE)

- Find the solution set for  $3 \tan^2 \theta - 2 \sin \theta = 0$ .
- Find the number of distinct solutions of  $\sec \theta + \tan \theta = 3$ ,  $0 \leq \theta \leq 3\pi$ .
- Find the number of values of  $x \in [0, 2\pi]$  that satisfy  $\cot x - \operatorname{cosec} x = 2 \sin x$ .
- The questions given below consist of an assertion (A) and the reason (R). Use the following key to choose the appropriate answer.
  - If both assertion and reason are correct and reason is the correct explanation of the assertion.
  - If both assertion and reason are correct but reason is not correct explanation of the assertion.
  - If assertion is correct, but reason is incorrect

(d) If assertion is incorrect, but reason is correct  
Now consider the following statements:

(i) **A:** The only solution of  $\cot \theta = \sin 2\theta$  is  $\theta = n\pi \pm \frac{\pi}{4}$

**R:**  $\frac{1}{\tan \theta} = \frac{2 \tan \theta}{1 + \tan^2 \theta} \Rightarrow 1 + \tan^2 \theta = 2 \tan^2 \theta$

$$\Rightarrow 1 = \tan^2 \theta \Rightarrow \theta = n\pi \pm \frac{\pi}{4}$$

(ii) **A:**  $\frac{\tan 3x - \tan 2x}{1 + \tan 3x \tan 2x} = 1$  have solution  $x = n\pi + \frac{\pi}{4}$

**R:**  $\frac{\tan A - \tan B}{1 + \tan A \tan B} = \tan(A - B)$

## Answer Keys

1.  $\theta = n\pi, \theta = n\pi + (-1)^n \pi/6$

2. 3

3. 0

4. (i) d (ii) d

**TEXTUAL EXERCISE-1 (OBJECTIVE)**

1. The general solution of the equations:

$$\sin \theta = -\frac{\sqrt{3}}{2} \text{ and } \tan \theta = \sqrt{3}$$

- (a)  $2n\pi - \frac{4\pi}{3}$  (b)  $2n\pi + \frac{4\pi}{3}$   
 (c)  $n\pi + \frac{4\pi}{3}$  (d) none of these

2.  $\sin x \cdot \sin(60^\circ - x) \cdot \sin(60^\circ + x) = 1/8$  and  $n \in \mathbb{Z}$ , then:

- (a)  $x = n\pi + (-1)^n \frac{\pi}{6}$  (b)  $x = \frac{n\pi}{3} + (-1)^n \frac{\pi}{18}$   
 (c)  $x = n\pi + (-1)^n \frac{\pi}{3}$  (d)  $x = \frac{n\pi}{3} + (-1)^n \frac{\pi}{9}$

3. The general solution for  $\alpha$  is, if

- (i)  $\sin \alpha, 1, \cos 2\alpha$  in G.P.

- (a)  $n\pi + (-1)^{n+1} \frac{\pi}{2}$  (b)  $n\pi + (-1)^n \frac{\pi}{2}$   
 (d)  $n\pi + (-1)^{n-1} \frac{\pi}{2}$  (d) None of these

- (ii)  $2\cos^2 \theta + 3\sin \theta = 0$

- (a)  $n\pi + (-1)^{n+1} \frac{2\pi}{3}$  (b)  $n\pi + (-1)^{n-1} \frac{\pi}{6}$   
 (c)  $n\pi + (-1)^{n+1} \frac{\pi}{6}$  (d) None of these

- (iii)  $1/6 \sin \alpha, \cos \alpha, \tan \alpha$  in G.P.

- (a)  $2n\pi - \frac{\pi}{3}$  (b)  $2n\pi + \frac{\pi}{3}$   
 (c)  $2n\pi \pm \frac{\pi}{3}$  (d) None of these

- (iv)  $\sin^2 \alpha - \cos \alpha = 1/4$  for  $0 \leq \alpha \leq 2\pi$ .

- (a)  $\frac{2\pi}{3}, \frac{\pi}{3}$  (b)  $\frac{2\pi}{3}, \frac{5\pi}{3}$   
 (c)  $\frac{5\pi}{3}, \frac{7\pi}{3}$  (d)  $\frac{\pi}{3}, \frac{5\pi}{3}$

- (v)  $2 \sin^2 \alpha + \sqrt{3} \cos \alpha + 1 = 0$

- (a)  $2n\pi + \frac{5\pi}{6}$  (b)  $2n\pi \pm \frac{5\pi}{6}$   
 (c)  $2n\pi - \frac{5\pi}{6}$  (d) None of these

4. The solution of the equation  $\tan 2\theta \tan \theta = 1$  is

- (a)  $\theta = n\pi \pm \frac{\pi}{6}$  (b)  $\theta = \frac{n\pi}{3} + \frac{\pi}{4}$   
 (c)  $\theta = \frac{n\pi}{3} - \frac{\pi}{6}$  (d) None of these

5. The general solution of the equation

$$\tan \theta + \tan 2\theta + \sqrt{3} \tan \theta \tan 2\theta = \sqrt{3} \text{ is}$$

- (a)  $\theta = (3n+1)\frac{\pi}{9}$  (b)  $\theta = \frac{n\pi}{9}$   
 (c)  $\theta = (3n-1)\frac{\pi}{9}$  (d) None of these

6. The number of distinct value of  $\theta$  satisfying  $0 \leq \theta \leq \pi$  and satisfying the equation  $\sin \theta + \sin 5\theta = \sin 3\theta$  is equal to

- (a) 6 (b) 7  
 (c) 8 (d) 9

7. If  $\sin \theta + \cos \theta = 1$ , then the general value of  $\theta$  is

- (a)  $2n\pi$  (b)  $n\pi + (-1)^n \frac{\pi}{4} - \frac{\pi}{4}$   
 (c)  $2n\pi + \frac{\pi}{2}$  (d) None of these

8. General solution of the equation  $\cot \theta - \tan \theta = 2$  is

- (a)  $n\pi + \frac{\pi}{4}$  (b)  $\frac{n\pi}{2} + \frac{\pi}{8}$   
 (c)  $\frac{n\pi}{2} \pm \frac{\pi}{8}$  (d) None of these

9. If  $\sin^2 \theta - 2\cos \theta + \frac{1}{4} = 0$ , then the general value of  $\theta$  is

- (a)  $n\pi \pm \frac{\pi}{3}$  (b)  $2n\pi \pm \frac{\pi}{3}$   
 (c)  $2n\pi \pm \frac{\pi}{6}$  (d)  $n\pi \pm \frac{\pi}{6}$

10. If  $2\tan^2 \theta = \sec^2 \theta$ , then the general value of  $\theta$  is

- (a)  $n\pi + \frac{\pi}{4}$  (b)  $n\pi - \frac{\pi}{4}$   
 (c)  $n\pi \pm \frac{\pi}{4}$  (d)  $n\pi - \frac{\pi}{4}$

11. The most general value of  $\theta$  satisfying the equations  $\sin \theta = \sin \alpha$  and  $\cos \theta = \cos \alpha$  is

- (a)  $2n\pi + \alpha$  (b)  $2n\pi - \alpha$   
 (c)  $n\pi + \alpha$  (d)  $n\pi - \alpha$

12. The sum of all the solutions of the equation

$$\cos x \cdot \cos \left( \frac{\pi}{3} + x \right) \cdot \cos \left( \frac{\pi}{3} - x \right) = \frac{1}{4}, x \in [0, 6\pi] \text{ is}$$

- (a)  $15\pi$  (b)  $30\pi$   
 (c)  $\frac{110\pi}{3}$  (d) None of these



## Answer Keys

1. (b)    2. (b)    3. (i) (a) (ii) (c) (iii) (c) (iv) (d) (v) (b)    4. (a)    5. (a)    6. (a)    7. (b)  
 8. (b)    9. (b)    10. (c)    11. (a)    12. (b)

### TRIGONOMETRIC EQUATION OF SOME SPECIAL FORMS

#### Equation of Form: $(a \cos x + b \sin x = c)$

It is known that for any ordered pair  $(a, b)$  of real numbers (not simultaneously zero) there exists a corresponding pair of real numbers  $r$  and  $\theta$  such that  $r > 0$ . To see this, plot the point  $P(a, b)$  in the  $xy$ -plane ( $P$  may lie in any quadrant or on any axis).

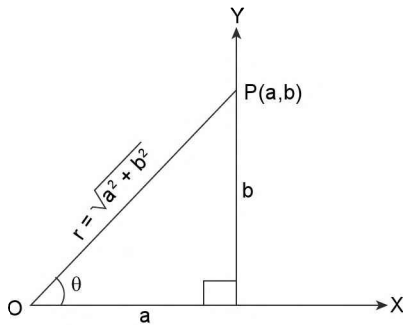

FIGURE 2.8

Join  $O$  to  $P$  and let its length be  $r$  and  $\angle XOP = \theta$ , where  $\theta$  is measured in the positive direction. From the very

definitions of  $\sin\theta$  and  $\cos\theta$ , we have  $\cos\theta = a/r$  and  $\sin\theta = b/r$ , where  $a = r \cos\theta$  and  $b = r \sin\theta$ . Here  $r = \sqrt{a^2 + b^2}$  and  $\theta = \tan^{-1}(b/a)$

The angle  $\theta$  should satisfy  $r \cos\theta = a$  and  $r \sin\theta = b$  and so lies in the same quadrant as  $P(a, b)$ .

The given equation then becomes  $r \cos\theta \cos x + r \sin\theta \sin x = c$

Hence  $r \cos(x - \theta) = c$ ; i.e.,  $\cos(x - \theta) = c/r$

For this equation to have a solution, we must have

$$-1 \leq c/r \leq 1 \text{ i.e., } -\sqrt{a^2 + b^2} \leq c \leq \sqrt{a^2 + b^2}$$

If  $\cos\alpha = c/r$ , then the general solution is given by  $x - \theta = 2n\pi \pm \alpha$ ,  $n \in \mathbb{Z}$

$$\Rightarrow x = 2n\pi + \theta \pm \alpha, n \in \mathbb{Z}$$

Thus a criterion for the solvability of the equation is

$$|c| \leq \sqrt{a^2 + b^2}$$

In simple cases, it is advisable to divide the given equation directly by  $\sqrt{a^2 + b^2}$  and recognise  $\frac{a}{\sqrt{a^2 + b^2}}$  and

$\frac{b}{\sqrt{a^2 + b^2}}$  as  $\cos\theta$  and  $\sin\theta$  for some suitable angle  $\theta$ .

**ILLUSTRATION 29:** Solve the equation  $\sqrt{3} \cos x - \sin x = 1$ .

**SOLUTION:** Given equation is  $\sqrt{3} \cos x - \sin x = 1$

Dividing both sides of the equation by  $\sqrt{(\sqrt{3})^2 + (-1)^2} = 2$ ,

we obtain  $(\sqrt{3}/2) \cos x - (1/2) \sin x = 1/2$ .

Observing that  $(\sqrt{3}/2) = \cos \frac{\pi}{6}$  and  $(1/2) = \sin \frac{\pi}{6}$ ,

we get  $\cos \frac{\pi}{6} \cos x - \sin \frac{\pi}{6} \sin x = 1/2$ .

That is  $\cos\left(x + \frac{\pi}{6}\right) = 1/2 = \cos \frac{\pi}{3}$ , which gives  $x + \frac{\pi}{6} = 2n\pi \pm \frac{\pi}{3}$ ,  $n \in \mathbb{Z}$ .

Hence the solution is  $x = 2n\pi - \frac{\pi}{6} \pm \frac{\pi}{3}$ ,  $n \in \mathbb{Z}$

**Algorithm:** Thus we can conclude that to solve the equation  $a \cos x + b \sin x = c$ , following steps should be taken:

1. Put  $a = r \cos \phi$ ,  $b = r \sin \phi$ ;

$$r = \sqrt{a^2 + b^2}, \text{ and } \phi = \tan^{-1} \frac{b}{a}$$

2. Substituting these values in the equation we have,  
 $r \cos \phi \cos x + r \sin \phi \sin x = c$

$$\Rightarrow r \cos(x - \phi) = c \quad \Rightarrow \cos(x - \phi) = \frac{c}{r}$$

$$\Rightarrow \cos(x - \phi) = \frac{c}{\sqrt{a^2 + b^2}}$$

**Case I:** If  $|c| > \sqrt{a^2 + b^2}$ , then the equation;  $a \cos x + b \sin x = c$  has no solution.

**Case II:** If  $|c| \leq \sqrt{a^2 + b^2}$ , then put;  $\frac{|c|}{\sqrt{a^2 + b^2}} = \cos \alpha$ ,  
 so that  $\cos(x - \theta) = \cos \alpha$

$$\Rightarrow x - \theta = 2n\pi \pm \alpha, n \in Z$$

$$\Rightarrow x = 2n\pi + \theta \pm \alpha, n \in Z$$

**ILLUSTRATION 30:** Solve the equation  $\sin x + \sqrt{3} \cos x = \sqrt{2}$ .

**SOLUTION:** Given  $\sqrt{3} \cos x + \sin x = \sqrt{2}$ ; dividing both sides by  $\sqrt{a^2 + b^2}$

$$\Rightarrow \frac{\sqrt{3}}{2} \cos x + \frac{1}{2} \sin x = \frac{\sqrt{2}}{2} = \frac{1}{\sqrt{2}} \Rightarrow \cos\left(x - \frac{\pi}{6}\right) = \cos\left(\frac{\pi}{4}\right) \Rightarrow x - \frac{\pi}{6} = 2n\pi \pm \frac{\pi}{4}$$

$$\Rightarrow x = 2n\pi \pm \frac{\pi}{4} + \frac{\pi}{6} \Rightarrow x = 2n\pi + \frac{5\pi}{12}, 2n\pi - \frac{\pi}{12}$$

**ILLUSTRATION 31:** Prove that:  $p \cos x - q \sin x = r$  admits solution for  $x$  iff  $-\sqrt{p^2 + q^2} < r < \sqrt{p^2 + q^2}$

**SOLUTION:** Here, we have  $p \cos x - q \sin x = r$

dividing both sides by  $\sqrt{p^2 + q^2}$ , we get  $\frac{p}{\sqrt{p^2 + q^2}} \cos x - \frac{q}{\sqrt{p^2 + q^2}} \sin x = \frac{r}{\sqrt{p^2 + q^2}}$  .....(i)

put,  $\frac{p}{\sqrt{p^2 + q^2}} = \cos \phi$ ,  $\frac{q}{\sqrt{p^2 + q^2}} = \sin \phi$  in the equation (i),

we get,  $\cos \phi \cos x - \sin \phi \sin x = \frac{r}{\sqrt{p^2 + q^2}} \Rightarrow \cos(x + \phi) = \frac{r}{\sqrt{p^2 + q^2}}$

as we know  $-1 \leq \cos(x + \phi) \leq 1$

$\therefore$  the above equation posses solution only if  $-1 \leq \frac{r}{\sqrt{p^2 + q^2}} \leq 1$

i.e., when  $-\sqrt{p^2 + q^2} \leq r \leq \sqrt{p^2 + q^2}$

**ILLUSTRATION 32:** Evaluate  $x$  if  $\frac{\sin x + i \cos x}{1 + i}$  is purely imaginary, where  $i = \sqrt{-1}$

**SOLUTION:** Here  $\frac{\sin x + i \cos x}{1 + i} = \frac{(1 - i)(\sin x + i \cos x)}{(1 - i)(1 + i)} = \frac{\sin x + \cos x + i(\cos x - \sin x)}{2}$

As per the question it has to be purely imaginary so real part must be zero  $\Rightarrow \sin x + \cos x = 0$

**ILLUSTRATION 33:** For  $x \in (-\pi, \pi)$  find the value of  $x$  for which the given equation  $(\sqrt{3} \sin x + \cos x)^{\sqrt{3} \sin 2x - \cos 2x + 2} = 1$  is satisfied.

**SOLUTION:**  $\left[ 2 \left\{ \sin \left( x + \frac{\pi}{6} \right) \right\} \right]^{\sqrt{2\sqrt{3} \sin x \cos x - \cos^2 x + \sin^2 x + 2 \cos^2 x + 2 \sin^2 x}} = 1 \Rightarrow \left[ 2 \left\{ \sin \left( x + \frac{\pi}{6} \right) \right\} \right]^{\sqrt{3 \sin^2 x + \cos^2 x + 2\sqrt{3} \sin x \cos x}} = 1$

$$\Rightarrow \left[ 2 \left\{ \sin \left( x + \frac{\pi}{6} \right) \right\} \right]^{\sqrt{3} \sin x + \cos x} = 1 \Rightarrow \left[ 2 \left\{ \sin \left( x + \frac{\pi}{6} \right) \right\} \right]^{\left| 2 \sin \left( x + \frac{\pi}{6} \right) \right|} = 1$$

To make the RHS well defined it is necessary that  $\sin \left( x + \frac{\pi}{6} \right) > 0 \Rightarrow x \in \left( -\frac{\pi}{6}, \frac{5\pi}{6} \right)$

$$\Rightarrow \left\{ 2 \sin \left( x + \frac{\pi}{6} \right) \right\}^{2 \sin \left( x + \frac{\pi}{6} \right)} = 1. \text{ This equation is of the type } t^t = 1 \text{ with } t \in (0, 2]$$

$$\Rightarrow t \ln t = 0 \Rightarrow t = 0 \text{ or } t = 1, \text{ but } t \text{ cannot be equal to } 0 \Rightarrow t = 1$$

$$\text{Hence } 2 \sin \left( x + \frac{\pi}{6} \right) = 1 \Rightarrow \sin \left( x + \frac{\pi}{6} \right) = \frac{1}{2} \Rightarrow x + \frac{\pi}{6} = \frac{\pi}{6} \text{ or } \frac{5\pi}{6} \Rightarrow x = 0 \text{ or } x = \frac{2\pi}{3}$$

### TEXTUAL EXERCISE-6 (SUBJECTIVE)

- |  |  |
|--|--|
| <p>1. Find the number of solutions of <math>\cos x =  1 + \sin x </math> for all <math>0 \leq x \leq 3\pi</math>.</p> <p>2. Solve the equation <math>(\sin x + \cos x)^{1 + \sin 2x} = 2</math> when <math>-\pi \leq x \leq \pi</math>.</p> <p>3. Solve the following equations for <math>\theta</math>:<br/> <math>(\sqrt{2} - 1) \cos \theta + \sin \theta = 1</math>.</p> | <p>4. Solve the following equations for <math>\theta</math>:<br/> <math>2 \cos \theta + 3 \sin \theta = 3</math>.</p> <p>5. Find the total number of integral values of 'n' so that <math>\sin x (\sin x + \cos x) = n</math> has at least one solution.</p> |
|--|--|

### Answer Keys

- |   |                |   |
|---|----------------|---|
| 1. no. of solutions are 3; i.e., 0, $3\pi/2$ , $2\pi$   | 2. $x = \pi/4$ | 3. $\theta = 2n\pi + \frac{\pi}{4}, n \in \mathbb{Z}$ |
| 4. $(4n + 1) \frac{\pi}{2}, (4n - 1) \frac{\pi}{2} + 2\alpha, n \in \mathbb{Z}$ where $\alpha = \tan^{-1}(3/2)$ | 5. 2           |   |

### Equation of the Form: $a_0 \sin^n x + a_1 \sin^{n-1} x \cos x + a_2 \sin^{n-2} x \cos^2 x + \dots + a_n \cos^n x = 0$ ,

where  $a_0, a_1, \dots, a_n$  are real numbers and the sum of the exponents in  $\sin x$  and  $\cos x$  in each term is

equal to  $n$ , are said to be homogeneous with respect to  $\sin x$  and  $\cos x$  of degree 'n'. For  $\cos x \neq 0$ , above equation can be written as,  $a_0 \tan^n x + a_1 \tan^{n-1} x + \dots + a_n = 0$

**ILLUSTRATION 34:** Solve the equation  $5 \sin^2 x - 7 \sin x \cos x + 16 \cos^2 x = 4$

**SOLUTION:** To solve this equation we use the universal trigonometric identity:  $\sin^2 x + \cos^2 x = 1$   
 To write the equation in the form  $5 \sin^2 x - 7 \sin x \cos x + 16 \cos^2 x = 4(\sin^2 x + \cos^2 x)$

$$\Rightarrow \sin^2 x - 7 \sin x \cos x + 12 \cos^2 x = 0$$

dividing both sides by  $\cos^2 x$ , we get  $\tan^2 x - 7 \tan x + 12 = 0$

Now it can be factorized as  $(\tan x - 3)(\tan x - 4) = 0$

$$\Rightarrow \tan x = 3 \text{ or } \tan x = 4 \text{ i.e., } \tan x = \tan(\tan^{-1} 3) \text{ or } \tan x = \tan(\tan^{-1} 4)$$

$$\Rightarrow x = n\pi + \tan^{-1} 3 \text{ or } x = n\pi + \tan^{-1} 4$$

**TEXTUAL EXERCISE-7 (SUBJECTIVE)**

- Solve the equation  $2 \sin^2 x - 5 \sin x \cos x - 8 \cos^2 x = -2$
- Solve:  $3 \cos^2 \theta - 2\sqrt{3} \sin \theta \cos \theta + \sin^2 \theta = 0$
- Solve the equation  $6 \sin^2 \theta - \sin \theta \cos \theta - \cos^2 \theta = 3$
- Find the set of values of  $\theta$  for which the pair of quadratic equations  $x^2 + 2x + 3 = 0$  and  $(2 \sin \theta)x^2 - (4\sqrt{3} \cos \theta)x + 3\sqrt{3} = 0$  have a common root.

**Answer Keys**

- $x = n\pi + \tan^{-1} 2$  and  $n\pi + \tan^{-1} (-3/4)$
- $\theta = n\pi + \pi/3$
- $n\pi - \pi/4$  or  $n\pi + \tan^{-1} \frac{4}{3}$
- $2n\pi + 2\pi/3$

**TEXTUAL EXERCISE-2 (OBJECTIVE)**

- The equation  $a \sin x + b \cos x = c$  where  $|c| > \sqrt{a^2 + b^2}$  has
  - one solution
  - two solution
  - no solution
  - infinite number of solutions
- The number of solutions of  $\cos \theta + \sqrt{3} \sin \theta = 5$ ,  $0 \leq \theta \leq 5\pi$  is
  - 4
  - 0
  - 5
  - None of these
- If  $\sin x + \sqrt{3} \cos x = \sqrt{2}$ , then  $x$  is
  - $2n\pi + \frac{\pi}{12}, 2n\pi - \frac{\pi}{3}$
  - $2n\pi + \frac{5\pi}{12}, 2n\pi - \frac{\pi}{12}$
  - $2n\pi + \frac{\pi}{12}, 2n\pi - \frac{\pi}{12}$
  - None of these
- If  $\sqrt{2} \sec \theta + \tan \theta = 1$ , then the general value  $\theta$  is
  - $n\pi + \frac{3\pi}{4}$
  - $n\pi + \frac{\pi}{4}$
  - $2n\pi - \frac{\pi}{4}$
  - $2n\pi \pm \frac{\pi}{4}$
- The number of solutions of the given equation  $\tan \theta + \sec \theta = \sqrt{3}$ , where  $0 < \theta < 2\pi$  is
  - 0
  - 1
  - 2
  - 3
- If  $|k| = 5$  and  $0^\circ \leq \theta \leq 360^\circ$ , then the number of different solution of  $3 \cos \theta + 4 \sin \theta = k$  is
  - Zero
  - Two
  - one
  - Infinite
- The number of solutions of the equation  $\tan x + \sec x = 2$   $\cos x$  lying in the interval  $[0, 2\pi]$ , is
  - 0
  - 1
  - 2
  - 3
- The equation  $k \cos x - 3 \sin x = k + 1$  is solvable only if
  - $k \in (-\infty, 4)$
  - $k \in (-\infty, 4]$
  - $k \in (4, \infty)$
  - None of these
- The equation  $\sin^4 x + \cos^4 x + \sin 2x + \alpha = 0$  is solvable for all  $\alpha$ ; where
  - $-\frac{1}{2} \leq \alpha \leq \frac{1}{2}$
  - $-3 \leq \alpha \leq 1$
  - $-\frac{3}{2} \leq \alpha \leq \frac{1}{2}$
  - $-1 \leq \alpha \leq 1$
- From the identity  $\sin 3x = 3 \sin x - 4 \sin^3 x$  it follows that if  $x$  is real and  $|x| < 1$ , then
  - $(3x - 4x^3) > 1$
  - $(3x - 4x^3) \leq 1$
  - $(3x - 4x^3) < 1$
  - nothing can be said about  $3x - 4x^3$
- If  $3 \sin x + 4 \cos ax = 7$  has at least one solution, then  $a$  has to be necessarily
  - odd integer
  - even integer
  - rational number
  - irrational number
- If the equation  $a_1 + a_2 \cos 2x + a_3 \sin^2 x = 1$  is satisfied by every real value of  $x$ , then the number of possible values of the triplet  $(a_1, a_2, a_3)$  is
  - 0
  - 1
  - 3
  - infinite

2.24 > Trigonometry

13. If  $\cos^4 x + a \cos^2 x + 1 = 0$  has at least one solution, then

- (a)  $a \in [2, \infty)$       (b)  $a \in [-2, 2)$   
 (c)  $a \in (-\infty, -2)$       (d)  $a \in \mathbb{R} - (-2, 2)$

14.  $\sin \theta + \sqrt{3} \cos \theta = 6x - x^2 - 11$ ,  $0 \leq \theta \leq 4\pi$ ,  $x \in \mathbb{R}$  holds for

- (a) No value of  $x$  and  $\theta$   
 (b) One value of  $x$  and two values of  $\theta$   
 (c) Two values of  $x$  and two values of  $\theta$   
 (d) None of these

15. Solution of the equation

$$\sin x + \cos x - 2\sqrt{2} \sin x \cos x = 0 \text{ is}$$

(a)  $x = (8k + 3) \cdot \frac{\pi}{12}$  or  $x = 2k\pi + \frac{\pi}{4}$ ;  $k \in \mathbb{Z}$

(b)  $x = n\pi + \frac{\pi}{4}$

(c)  $x = (2n\pi + 1) \frac{\pi}{4}$

(d) None of these

16. If the equation  $2 \cos x + \cos 2kx = 3$  has only one solution, then

- (a)  $k \in$  set of rational nos.  
 (b)  $k \in$  set of irrational nos.  
 (c)  $k \in$  set of integers  
 (d) None of these

## Answer Keys

1. (c)    2. (b)    3. (b)    4. (c)    5. (b)    6. (b)    7. (c)    8. (b)    9. (c)    10. (d)  
 11. (c)    12. (d)    13. (c)    14. (c)    15. (a)    16. (b)

### A Trigonometric Equation of the Form:

$$\mathbb{R}(\sin kx, \cos nx, \tan mx, \cot lx) = 0$$

where  $\mathbb{R}$  is a rational function of the indicated arguments and  $(k, l, m, n$  are natural numbers) can be reduced to a rational equation with respect to the arguments  $\sin x$ ,  $\cos x$ ,  $\tan x$ , and  $\cot x$  by means of the formula for trigonometric functions of the sum of angles (in particular, the formulae

for double and triple angles) and then reduce equation (i) to a rational equation with respect to the new unknown,  $t = \tan x/2$ . By means of the formulae,

$$\sin x = \frac{2 \tan x/2}{1 + \tan^2 x/2}, \quad \cos x = \frac{1 - \tan^2 x/2}{1 + \tan^2 x/2}$$

$$\tan x = \frac{2 \tan x/2}{1 - \tan^2 x/2}, \quad \cot x = \frac{1 - \tan^2 x/2}{2 \tan x/2}$$

**ILLUSTRATION 35:** Solve the equation  $(1 - \tan \theta)(1 + \sin 2\theta) = 1 + \tan \theta$  for real values of  $\theta$ .

**SOLUTION:**  $(1 - \tan \theta) \left( 1 + \frac{2 \tan \theta}{1 + \tan^2 \theta} \right) = 1 + \tan \theta \Rightarrow (1 - \tan \theta) \frac{1 + \tan^2 \theta + 2 \tan \theta}{1 + \tan^2 \theta} = 1 + \tan \theta$

$$\Rightarrow (1 - \tan \theta)(1 + \tan^2 \theta) = (1 + \tan \theta)(1 + \tan^2 \theta)$$

$$\Rightarrow (1 + \tan \theta)(1 - \tan \theta)(1 + \tan \theta) - (1 + \tan^2 \theta) = 0$$

$$\Rightarrow (1 + \tan \theta)(1 - \tan^2 \theta - 1 - \tan^2 \theta) = 0$$

$$\Rightarrow (1 + \tan \theta)(-2 \tan^2 \theta) = 0 \Rightarrow \tan^2 \theta (1 + \tan \theta) = 0$$

$$\text{when } \tan^2 \theta = 0 \Rightarrow \tan \theta = 0 \Rightarrow \theta = n\pi$$

$$\text{when } 1 + \tan \theta = 0, \tan \theta = -1 = \tan(-\pi/4) \Rightarrow \theta = n\pi + (-\pi/4) = n\pi - \pi/4$$

Thus  $\theta = n\pi, n\pi - \pi/4$ , where  $n \in \mathbb{Z}$  is the required general solution

**ILLUSTRATION 36:** Solve the equation  $(\cos x - \sin x) \left( 2 \tan x + \frac{1}{\cot x} \right) + 2 = 0$  for real  $x$ .

**SOLUTION:** Let  $y = \tan x/2$  and using the formula. We get

$$\left\{ \frac{1 - \tan^2 x/2}{1 + \tan^2 x/2} - \frac{2 \tan x/2}{1 + \tan^2 x/2} \right\} \left\{ \frac{4 \tan x/2}{1 - \tan^2 x/2} + \frac{1 + \tan^2 x/2}{1 + \tan^2 x/2} \right\} + 2 = 0$$

$$\Rightarrow \left\{ \frac{1 - t^2}{1 + t^2} - \frac{2t}{1 + t^2} \right\} \left\{ \frac{4t}{1 - t^2} + \frac{1 + t^2}{1 + t^2} \right\} + 2 = 0$$

$$\Rightarrow \frac{3t^4 + 6t^3 + 8t^2 - 2t - 3}{(t^2 + 1)(1 - t^2)} = 0$$

$$\Rightarrow 3t^4 + 6t^3 + 8t^2 - 2t - 3 = 0$$

Its roots are  $t_1 = \frac{1}{\sqrt{3}}$  and  $t_2 = -\frac{1}{\sqrt{3}}$  (Hit and Trial)

Thus the solution of the equation reduces to that of two elementary equations

$$\tan \frac{x}{2} = \frac{1}{\sqrt{3}} \text{ or } \tan \frac{x}{2} = -\frac{1}{\sqrt{3}} \text{ i.e., } \tan^2 \frac{x}{2} = \frac{1}{3} = \tan^2 \frac{\pi}{6}$$

$$\Rightarrow \frac{x}{2} = n\pi \pm \frac{\pi}{6} \Rightarrow x = 2n\pi \pm \frac{\pi}{3} \text{ is the required general solution}$$

### Equation of the Form: $\mathbb{R} (\sin x + \cos x, \sin x \cos x) = 0$

In the given equation  $R$  is a rational function. Equations containing  $\sin x \pm \cos x$  and  $\sin x \cos x$  can be solved easily by substituting  $\sin x \pm \cos x = t$

**Step I:** Supposing  $(\sin x + \cos x)$  or  $(\sin x - \cos x)$  as the case may be equal to  $t$ , find the value of  $\sin x \cos x$  in terms of  $t$  using the following identities:

$$(\sin x \pm \cos x)^2 = \sin^2 x + \cos^2 x \pm 2 \sin x \cos x = 1 \pm 2 \sin x \cos x$$

$$\text{e.g., if we put } \sin x + \cos x = t \quad \dots (i)$$

$$\Rightarrow \sin x \cos x = \frac{t^2 - 1}{2} \quad \dots (ii)$$

**Step II:** Taking (i) and (ii) into account, we can reduce the given equation into;  $R(t, (t^2 - 1)/2) = 0$  and evaluate  $t$ . (Similarly, by the substitution  $(\sin x - \cos x) = t$ , we can reduce the above equation into  $R(t, (1 - t^2)/2) = 0$ )

**Step III:** For each value of  $t$  the original equation changes to new equation of the type  $\sin x \pm \cos x = t$  which can further be solved easily.

**ILLUSTRATION 37:** Solve the equation  $\sin x + \cos x = 1 + \sin x \cos x$

**SOLUTION:** The given equation is  $\sin x + \cos x = 1 + \sin x \cos x \quad \dots (i)$

Let  $\sin x + \cos x = z$ , by squaring we get

$$1 + 2 \sin x \cos x = z^2 \Rightarrow \sin x \cos x = \frac{z^2 - 1}{2}$$

Substituting these values in the equation (i), we get

$$\Rightarrow z = 1 + \frac{z^2 - 1}{2} \Rightarrow z^2 - 2z + 1 = 0 \Rightarrow (z - 1)^2 = 0$$

$$\Rightarrow z = 1 \text{ i.e., } \sin x + \cos x = 1$$

Now dividing both sides of the equation by  $\sqrt{2}$ , we have  $\frac{1}{\sqrt{2}} \cos x + \frac{1}{\sqrt{2}} \sin x = \frac{1}{\sqrt{2}}$

$$\Rightarrow \cos(x - \pi/4) = \cos \pi/4 \Rightarrow x - \pi/4 = 2n\pi \pm \pi/4$$

Taking positive sign,  $x - \pi/4 = 2n\pi + \pi/4$

$$\Rightarrow x = 2n\pi + \pi/2 = (4n+1)\frac{\pi}{2}$$

Taking negative sign  $x - \pi/4 = 2n\pi - \pi/4$

$$\Rightarrow x = 2n\pi, (4n+1)\frac{\pi}{2} \text{ where } n \in \mathbb{Z} \text{ is general solution}$$

**ILLUSTRATION 38:** Solve the equation  $\sin x + \cos x - 2\sqrt{2} \sin x \cos x = 0$

**SOLUTION: Method 1:** Put  $\sin x + \cos x = t \Rightarrow 2 \sin x \cos x = t^2 - 1$

$$\Rightarrow t - \sqrt{2}t^2 + \sqrt{2} = 0 \Rightarrow \sqrt{2}t^2 - t - \sqrt{2} = 0$$

The numbers  $t_1 = \sqrt{2}$ ,  $t_2 = -1/\sqrt{2}$  are roots of this quadratic equation.

Thus the solution of the given equation reduces to the solution of two trigonometric equations:

$$\sin x + \cos x = \sqrt{2} \text{ and } \sin x + \cos x = -\frac{1}{\sqrt{2}}$$

$$\Rightarrow \frac{1}{\sqrt{2}} \sin x + \frac{1}{\sqrt{2}} \cos x = 1 \text{ and } \frac{1}{\sqrt{2}} \sin x + \frac{1}{\sqrt{2}} \cos x = -\frac{1}{2}$$

$$\Rightarrow \sin x \cos \frac{\pi}{4} + \sin \frac{\pi}{4} \cos x = 1 \text{ and } \sin x \cos \frac{\pi}{4} + \sin \frac{\pi}{4} \cos x = -\frac{1}{2}$$

$$\Rightarrow \sin\left(x + \frac{\pi}{4}\right) = 1 \text{ and } \sin\left(x + \frac{\pi}{4}\right) = -\frac{1}{2}$$

$$\Rightarrow x + \frac{\pi}{4} = (4n+1)\frac{\pi}{2} \text{ and } x + \frac{\pi}{4} = n\pi + (-1)^n\left(-\frac{\pi}{6}\right)$$

$$\Rightarrow x = 2n\pi + \frac{\pi}{4} \text{ and } x = n\pi - (-1)^n\frac{\pi}{6} - \frac{\pi}{4}$$

**Method 2:** Here  $\sin x + \cos x = 2\sqrt{2} \sin x \cos x = \sqrt{2} \sin 2x$  .....(i)

$$\text{or } \sqrt{2} \left( \frac{1}{\sqrt{2}} \sin x + \frac{1}{\sqrt{2}} \cos x \right) = \sqrt{2} \sin 2x \text{ or } \sin\left(x + \frac{\pi}{4}\right) = \sin 2x$$

$$\Rightarrow 2x = n\pi + (-1)^n (x + \pi/4)$$

Taking  $n$  to be even integer i.e.,  $n = 2m$ ,  $m \in \mathbb{Z}$ . Then  $2x = 2m\pi + x + \pi/4$

$$\therefore x = 2m\pi + \pi/4 \text{ where } m \in \mathbb{Z}$$

Taking  $n$  odd,  $n = 2m + 1$ ,  $m \in \mathbb{Z}$

Then  $3x = (2m + 1)\pi - \pi/4$ ;

$$\Rightarrow x = \frac{2m+1}{3}\pi - \frac{\pi}{12}$$

Thus  $x = \left(2m + \frac{1}{4}\right)\pi$ ,  $\frac{1}{3}\left(2m + \frac{3}{4}\right)\pi$  where  $m \in \mathbb{Z}$

### Equation Involving Higher Even Power of $\sin x$ and $\cos x$

If the equation contains higher degrees of  $\sin x$  and  $\cos x$ , then results of multiple angle ( $\cos 2x = 2\cos^2 x - 1 = 1 - 2$

$\sin^2 x$  etc.) are used to reduce the degree of equation and thus the equation are solved conveniently.

**ILLUSTRATION 39:** Solve the equation  $\sin^4 x + \cos^4 x = \frac{7}{2} \sin x \cos x$ .

**SOLUTION:** We transform the expression  $\sin^4 x + \cos^4 x$  isolating a perfect square:

$$\sin^4 x + \cos^4 x = \sin^4 x + 2\sin^2 x \cos^2 x + \cos^4 x - 2\sin^2 x \cos^2 x = (\sin^2 x + \cos^2 x)^2 - 2\sin^2 x \cos^2 x$$

$$\text{where we get } \sin^4 x + \cos^4 x = 1 - \frac{1}{2} \sin^2 2x \quad \dots(i)$$

$$\text{Using (i), the given equation becomes } 1 - \frac{1}{2} \sin^2 2x = \frac{7}{4} \sin 2x$$

$$\Rightarrow 2\sin^2 2x + 7\sin 2x = 4 \Rightarrow (2\sin 2x - 1)(\sin 2x + 4) = 0$$

$$\text{either } 2\sin 2x - 1 = 0 \Rightarrow 2x = n\pi + (-1)^n \frac{\pi}{6} \text{ where } n \in \mathbb{Z}$$

$$\text{or } \sin 2x + 4 = 0 \text{ which has no solution because } \sin 2x \neq -4$$

$$\text{So, the solution of equation is } x = \frac{n\pi}{2} + (-1)^n \frac{\pi}{12} \text{ where } n \in \mathbb{Z}$$

**ILLUSTRATION 40:** Solve the equation  $\sin^{10} x + \cos^{10} x = \frac{29}{16} \cos^4 2x - \frac{5}{8}$ .

**SOLUTION:** Using the half-angle formulae we can represent the given equation in the form

$$\left(\frac{1 - \cos 2x}{2}\right)^5 + \left(\frac{1 + \cos 2x}{2}\right)^5 = \frac{29}{16} \cos^4 2x - \frac{5}{8}$$

$$\text{Substituting, } \cos 2x = t, \text{ we get } \left(\frac{1-t}{2}\right)^5 + \left(\frac{1+t}{2}\right)^5 = \frac{29}{16} t^4 - \frac{10}{16}$$

$$\Rightarrow 24t^4 + 10t^2 - 11 = 0 \text{ whose real root is } t^2 = 1/2$$

$$\therefore \cos^2 2x = 1/2$$

$$\Rightarrow 2x = n\pi \pm \pi/4 \text{ i.e., } n(\pi/2) \pm \pi/8 \quad \dots(ii)$$

$$\text{or } 1 + \cos 4x = 1 \Rightarrow \cos 4x = 0$$

$$\Rightarrow 4x = (2m + 1) \frac{\pi}{2} \Rightarrow x = \frac{m\pi}{4} + \frac{\pi}{8} \text{ } n, m \in \mathbb{Z} \text{ (set of integers)}$$

both the solutions are equivalent

**ILLUSTRATION 41:**  $3\sqrt{3} \sin^3 x + \cos^3 x + 3\sqrt{3} \sin x \cos x = 1$ .

**SOLUTION:** Let  $a = \sqrt{3} \sin x$ ;  $b = \cos x$ ;  $c = -1$ , then given equation reduces to  $a^3 + b^3 + c^3 - 3abc = 0$

$$\Rightarrow (a + b + c)(a^2 + b^2 + c^2 - ab - bc - ca) = 0$$

$$\Rightarrow (\sqrt{3} \sin x + \cos x - 1)(3\sin^2 x + \cos^2 x + 1 - \sqrt{3} \sin x \cos x + \cos x + \sqrt{3} \sin x) = 0$$

$$\Rightarrow (\sqrt{3} \sin x + \cos x - 1) \cdot \frac{1}{2} \left[ (\sqrt{3} \sin x - \cos x)^2 + (\cos x + 1)^2 + (-1 - \sqrt{3} \sin x)^2 \right] = 0$$



Thus the given equation has solution if  $\sqrt{3} \sin x + \cos x - 1 = 0$  as other factor gives  $\sqrt{3} \sin x = \cos x = -1$  which is impossible.

$$\Rightarrow \sqrt{3} \sin x + \cos x = 1 \Rightarrow \frac{\sqrt{3}}{2} \sin x + \frac{1}{2} \cos x = \frac{1}{2} \Rightarrow \sin \left( x + \frac{\pi}{6} \right) = \sin \frac{\pi}{6}$$

$$\Rightarrow \left( x + \frac{\pi}{6} \right) = n\pi + (-1)^n \frac{\pi}{6}$$

$$\text{If } n \text{ is odd; } \Rightarrow x = n\pi - \frac{\pi}{6} - \frac{\pi}{6} = n\pi - \frac{\pi}{3} \Rightarrow x = (2k+1)\pi - \frac{\pi}{3}; k \in \mathbb{Z}$$

$$\text{If } n \text{ is even } \Rightarrow x = n\pi + \frac{\pi}{6} - \frac{\pi}{6} = n\pi \Rightarrow x = 2m\pi, m \in \mathbb{Z}$$

### TEXTUAL EXERCISE-8 (SUBJECTIVE)

- Solve the equation  $7\cos^2 \theta + 3 \sin^2 \theta = 4$ .
- Solve the equation  $\sin^4 x + \cos^4 x = \sin x \cos x$ .
- Solve  $\sec x + \operatorname{cosec} x = 2\sqrt{2}$ .
- Find the number of solutions of the equation  $\sin^2 x - \sin x + \cos x = 1$  in the interval  $[-4\pi, 4\pi]$
- Solve the equation  $\sin^4 x + \cos^4 x = 1$
- Solve the equation  $\sin^2 x - 5\sin x \cos x - 6\cos^2 x = 0$

### Answer Keys

- $n\pi \pm \pi/3$
- $\frac{4n+1}{4}\pi, n \in \mathbb{Z}$
- $x = 2m\pi + \pi/4, x = (2m+1)\pi/3 - \pi/12; m \in \mathbb{Z}$
- 9 solutions
- $n\pi/2; n \in \mathbb{Z}$
- $n\pi - \pi/4, n\pi + \tan^{-1}6; n \in \mathbb{Z}$

### ■ SOLVING SIMULTANEOUS EQUATIONS

Here we discuss problems related to the solution of two equations satisfied simultaneously by one or more number of unknowns. We divide the problem into two categories:

- Two equations satisfied simultaneously by one unknown.
- Two equations satisfied simultaneously by two unknown.

### Equations with Only One Variable

To solve the simultaneous equation in one variable say  $x$ , we observe the following steps

**Step I:** Find values of  $x$  satisfying both the equation individually and lying in  $[0, 2\pi]$

**Step II:** Select the values satisfying both equations simultaneously.

**Step III:** Generalize the values to get the general solution.

**ILLUSTRATION 42:** Find the most general solution for satisfying the simultaneous equation  $\tan \theta = \sqrt{3}$  and  $\cos \theta = -1/2$ .

**SOLUTION:** The values of  $\theta$  satisfying both the equations individually and lying in  $\theta \in [0, 2\pi]$  are  $\tan \theta = \sqrt{3} \Rightarrow \theta = \pi/3, 4\pi/3$  and

$$\cos\theta = -1/2 \Rightarrow \theta = 2\pi/3 \text{ or } 4\pi/3$$

$\Rightarrow$  The common solution is  $\theta = 4\pi/3$

$\Rightarrow$  General solution is  $\theta = 2n\pi + 4\pi/3; n \in \mathbb{Z}$

**ILLUSTRATION 43:** Find the most general values of  $\theta$  which satisfies the equation  $\sin\theta = -1/2$  and  $\tan\theta = \frac{1}{\sqrt{3}}$ .

**SOLUTION:** First find the values of  $\theta$  lying between 0 and  $2\pi$  and satisfying the two given equations separately. Select the value of  $\theta$  which satisfies both the equations, and then generalizing it we obtain:

$$\sin\theta = -\frac{1}{2} \Rightarrow \theta = \frac{7\pi}{6} \text{ or } \frac{11\pi}{6}$$

$$\tan\theta = \frac{1}{\sqrt{3}} \Rightarrow \theta = \frac{\pi}{6} \text{ or } \frac{7\pi}{6} \text{ (values between 0 and } 2\pi\text{)}$$

common values of  $\theta = 7\pi/6$ . The required solution is  $\theta = 2n\pi + \frac{7\pi}{6}; n \in \mathbb{Z}$

## TEXTUAL EXERCISE-9 (SUBJECTIVE)

- Solve the system:  $\sin\theta = 1/\sqrt{2}$  and  $\cot\theta = -1$ .
- Solve the system:  $\sin\theta = \frac{-\sqrt{3}}{2}$  and  $\tan\theta = \sqrt{3}$ .
- Solve the system:  $\cos\theta = \frac{1}{\sqrt{2}}$  and  $\tan\theta = -1$ .
- Solve the system:  $\sin\theta = -1/2$  and  $\tan\theta = 1/\sqrt{3}$

- Solve the system of equations for  $x$  and  $y$ :

$$(i) \begin{cases} \sin(x+y) = 0 \\ \sin(x-y) = 0 \end{cases} \quad (ii) \begin{cases} \sin x \sin y = 0.25 \\ x+y = \frac{\pi}{3} \end{cases}$$

- Solve the system of equations for  $x$  and  $y$ :

$$\begin{cases} \frac{1-\tan x}{1+\tan x} = \tan y \\ x-y = \frac{\pi}{6} \end{cases}$$

## Answer Keys

- $(8n+3)\frac{\pi}{4}; x \in \mathbb{Z}$       2.  $2n\pi + 4\pi/3$       3.  $2n\pi - \pi/4$       4.  $(2n\pi + 7\pi/6)$
- (i)  $(n+m)\pi/2, (n-m)\pi/2$     (ii)  $(n\pi + \pi/6, -n\pi + \pi/6)$       6.  $\left(n\frac{\pi}{2} + \frac{5\pi}{24}, n\frac{\pi}{2} + \frac{\pi}{24}\right)$

## Equations with Two or More Variables

While going through the problems involving more than one variable in most of the cases you will find that one of the following approach may be employed to proceed smoothly and to crack the problem in short span of time.

- Substitute for one variable say  $y$  in forms of other variable  $x$  i.e., eliminate  $y$  and solve the way you

used to solve for trigonometric equations in one variables.

- Extract the linear/algebraic simultaneous equations from the given trigonometric equations and solve them as algebraic simultaneous equations.
- Many times you may need to make appropriate substitutions. It will be particularly useful when the system has only two trigonometric functions.

**ILLUSTRATION 44:** Solve the system of equations;  $x + y = 2\pi/3$  and  $\frac{\sin x}{\sin y} = 2$

**SOLUTION:** Given  $x + y = 2\pi/3$  .....(i)

and  $\frac{\sin x}{\sin y} = 2$  .....(ii)

Let us reduce the second equation of the system to the form  $\sin x = 2\sin y$  .....(i)  
using  $x + y = 2\pi/3$  we get  $\sin x = 2\sin(2\pi/3 - x)$

$$\Rightarrow \sin x = 2 \left( \sin \frac{2\pi}{3} \cdot \cos x - \cos \frac{2\pi}{3} \cdot \sin x \right) = 2 \left( \frac{\sqrt{3}}{2} \cdot \cos x + \frac{1}{2} \cdot \sin x \right)$$

$$\Rightarrow \sin x = \sqrt{3} \cos x + \sin x \quad \Rightarrow \cos x = 0 \Rightarrow x = \frac{\pi}{2} + n\pi$$

Substituting in  $x + y = 2\pi/3$ . we get  $y = -n\pi + \pi/6$

$$\therefore x = \frac{\pi}{2} + n\pi, y = -n\pi + \pi/6, \text{ where } n \in \mathbb{Z}$$

**ILLUSTRATION 45:** Find the points of intersection of the curves  $y = \cos x$  and  $y = \sin 3x$  if  $-\frac{\pi}{2} \leq x \leq \frac{\pi}{2}$

**SOLUTION:** Given curve is  $y = \cos x$  and  $y = \sin 3x$

Now, for points of intersection both equations must be satisfied

$$\therefore \cos x = \sin 3x \text{ or } \cos x = \cos(\pi/2 - 3x) \Rightarrow x = 2n\pi \pm (\pi/2 - 3x)$$

$$\text{when } x = 2n\pi + \pi/2 - 3x, x = n\pi/2 + \pi/8$$

$$\text{when } x = 2n\pi - \pi/2 + 3x, x = -n\pi + \pi/4$$

Putting  $n \in \mathbb{Z}$  we have the values of  $x$  within given interval  $\frac{\pi}{8}, \frac{-3\pi}{8}, \frac{\pi}{4}$

$$\text{Values of } y \text{ within the given interval} = \cos \frac{\pi}{8}, \cos \left( \frac{-3\pi}{8} \right), \cos \frac{\pi}{4}$$

Hence points of intersection will be given by  $\left( \frac{-3\pi}{8}, \cos \frac{3\pi}{8} \right), \left( \frac{\pi}{8}, \cos \frac{\pi}{8} \right), \left( \frac{\pi}{4}, \frac{1}{\sqrt{2}} \right)$

**ILLUSTRATION 46:** Find all values of  $\theta$  lying between 0 and  $2\pi$  satisfying the equations

$$r \sin \theta = \sqrt{3} \text{ and } r + 4\sin \theta = 2(\sqrt{3} + 1)$$

**SOLUTION:** Given equations are  $r \sin \theta = \sqrt{3}$  .....(i)

and  $r + 4\sin \theta = 2(\sqrt{3} + 1)$  .....(ii)

To find the values of  $\theta$  we must eliminate  $r$ .

$$\text{Now from (i) we get, } r = \frac{\sqrt{3}}{\sin \theta}$$

Substituting the value of  $r$  in (ii) we get

$$\Rightarrow \frac{\sqrt{3}}{\sin \theta} + 4\sin \theta = 2(\sqrt{3} + 1) \Rightarrow 4\sin^2 \theta - 2\sqrt{3} \sin \theta - 2\sin \theta + \sqrt{3} = 0$$

$$\Rightarrow 2\sin \theta (2\sin \theta - \sqrt{3}) - 1(2\sin \theta - \sqrt{3}) = 0 \Rightarrow (2\sin \theta - \sqrt{3})(2\sin \theta - 1) = 0$$

$$\Rightarrow 2\sin \theta - \sqrt{3} = 0, \sin \theta = \frac{\sqrt{3}}{2} = \sin \frac{\pi}{3} \Rightarrow \theta = n\pi + (-1)^n \frac{\pi}{3}$$

$$\Rightarrow 2 \sin \theta - 1 = 0, \sin \theta = \frac{1}{2} = \sin \frac{\pi}{6} \Rightarrow \theta = n\pi + (-1)^n \frac{\pi}{6}$$

Therefore values of  $\theta$  lying between 0 and  $2\pi$  are  $\frac{\pi}{6}, \frac{\pi}{3}, \frac{2\pi}{3}, \frac{5\pi}{6}$

**ILLUSTRATION 47:** Solve the system of the equation  $\sin^2 x + \sin^2 y = 1/2$  and  $x - y = 4\pi/3$ .

**SOLUTION:** We transform the first equation of the system  $\frac{1}{2}(1 - \cos 2x) + \frac{1}{2}(1 - \cos 2y) = \frac{1}{2}$

$$\cos 2x + \cos 2y = 1 \Rightarrow 2 \cos(x + y) \cdot \cos(x - y) = 1$$

Hence it is clear that the system has the same solution as the original system

i.e., the system of equations are equivalent

$$\cos(x + y) \cos(x - y) = \frac{1}{2} \quad \dots(i)$$

$$\text{and } x - y = 4\pi/3 \quad \dots(ii)$$

$$\text{So from the equation (i) and (ii) we have } \cos(x + y) \cos\left(\frac{4\pi}{3}\right) = \frac{1}{2}$$

$$\Rightarrow \cos(x + y) = -1 \Rightarrow x + y = 2n\pi \pm \pi$$

Hence we have two linear equations in  $x$  and  $y$

$$x + y = 2n\pi \pm \pi, n \in \mathbb{Z} \Rightarrow x - y = 4\pi/3$$

$$\text{Solving these two equations: } x = n\pi + \frac{2\pi}{3} \pm \frac{\pi}{2} \quad \dots(iii)$$

$$\text{Taking +ve sign of (iii) } x = (n + 7/6) \pi$$

$$y = k\pi, k = (n + 7/6) \text{ and } y = k\pi - 4\pi/3$$

$$\text{Taking -ve sign of (iii) } x = n\pi + \pi/6$$

$$y = n\pi + \pi/6 - 4\pi/3 = n\pi - 7\pi/6$$

The general solution of system of equation is given by

$$\left(k\pi, k\pi - \frac{4\pi}{3}\right) \text{ and } \left(n\pi + \frac{\pi}{6}, n\pi + \frac{7\pi}{6}\right) \text{ where } k, n \in \mathbb{Z}$$

so these are the solutions to the original system

## NOTES

1. While solving two dependent equations different letters should be taken to represent the generalized solution. Same letters in such case will cause a loss of roots. But while solving two independent equations we may take the same letter to represent the generalized solution. In the problem discussed above, the value of  $x$  and  $y$  depends on the values of  $x - y$  and  $x + y$  both. Change in even one causes change in the value of  $x$  and  $y$  and so we must take different letters for generalization of the two solutions.
2. In the above example, we have written the relationship between the unknowns  $x$  and  $y$  and the set of solution of the system has been expressed in terms of only one integral parameter e.g.,  $n, k$  etc. But in practical applications, we may sometimes be required to express the general solution in terms of two integral parameters while solving a system of equations with two variables.
3. Sometimes introducing a new variable helps in solving an equation efficiently. Introduction of new variables can be employed in those cases where a system contains only two trigonometric functions or can be reduced to such a form.

**ILLUSTRATION 48:** Solve the system  $\sin x + \cos x = 1$  and  $\cos 2x - \cos 2y = 1$

**SOLUTION:** Given equations are  $\sin x + \cos x = 1$  ..(i)

and  $\cos 2x - \cos 2y = 1$  ..(ii)

By putting  $\cos 2x = 1 - 2\sin^2 x$  and  $\cos 2y = 2\cos^2 y - 1$  in equation (ii), we get

$$\Rightarrow \cos 2x - \cos 2y = 1 - 2\sin^2 x + 1 - 2\cos^2 y = 1$$

$$\Rightarrow \sin^2 x + \cos^2 y = 1/2$$

and hence system is  $\sin x + \cos y = 1$  ..(iii)

$$\sin^2 x + \cos^2 y = 1/2$$
 ..(iv)

which is equivalent to the original system

Let us put  $\sin x = u$  and  $\cos y = v$ , ( $u \in [-1, 1]$  and  $v \in [-1, 1]$ )

$$u + v = 1$$
 ..(v)

$$\text{and } u^2 + v^2 = 1/2$$
 ..(vi)

Solving (v) and (vi), we get  $u = \sin x = 1/2$  and  $v = \cos y = 1/2$

Hence the general solution of the given system of equations is given by

$$x = m\pi + (-1)^m \frac{\pi}{6} \quad m \in \mathbb{Z}; \quad y = 2n\pi \pm \frac{\pi}{3}, \quad n \in \mathbb{Z}$$

The solution of various pairs formed from these values of  $x$  and  $y$  is precisely the set of all solution of the original system of equation.

### TEXTUAL EXERCISE-10 (SUBJECTIVE)

- If  $\cos(x - y) = 1/2$  and  $\sin(x + y) = 1/2$ , find the smallest positive values of  $x$  and  $y$  and also their most general values.
- Let  $A$  and  $B$  be acute positive angles satisfying the equations:  $3\sin^2 A + 2\sin^2 B = 1$  and  $3\sin 2A - 2\sin 2B = 0$  then prove that  $A + 2B = \pi/2$ .
- Solve the system of equations:  $x + y = \pi/4$  and  $\tan x + \tan y = 1$ .
- Solve the system of equations:  $\sin(x + y) = 0$  and  $\sin(x - y) = 0$ .
- Solve the system of equations:  $\sin x + \sin y = \sqrt{2}$  and  $\cos x \cos y = 1/2$ .

### Answer Keys

- $x = \frac{7\pi}{12}, y = \frac{\pi}{4}, x = (2n + m)\frac{\pi}{2} \pm \frac{\pi}{6} + (-1)^m \frac{\pi}{12}, y = (2m - 2n)\frac{\pi}{2} \pm \frac{\pi}{6} + (-1)^m \frac{\pi}{12}$
- $x = \pi/4 - n\pi, y = n\pi$  where  $n \in \mathbb{Z}$
- $x = (m + n)\frac{\pi}{2}, y = \frac{\pi}{2}(m - n)$  where  $m, n \in \mathbb{Z}$
- $x = (m + n)\pi \pm \frac{\pi}{4}, y = (n - m)\pi \pm \frac{\pi}{4}$  where  $m, n \in \mathbb{Z}$

### TEXTUAL EXERCISE-3 (OBJECTIVE)

- If  $-\pi \leq x \leq \pi, -\pi \leq y \leq \pi$  and  $\cos x + \cos y = 2$ , then the value  $\cos(x - y)$  is
 

(a) -1	(b) 0
(c) 1	(d) None of these
- Total number of solutions of  $\sin 2x - \sin x - 1 = 0$  in  $[-2\pi, 2\pi]$  is equal to
 

(a) 2	(b) 4
(c) 6	(d) 8

3. If  $0 \leq x \leq 3\pi, 0 \leq y \leq 3\pi$  and  $\cos x \cdot \sin y = 1$ , then the possible number of values of the ordered pair  $(x, y)$  is  
 (a) 6 (b) 12  
 (c) 8 (d) 15
4. If  $x, y \in [0, 2\pi]$ , then total number of ordered pairs  $(x, y)$  satisfying  $\sin x \cdot \cos y = 1$  is equal to  
 (a) 1 (b) 3  
 (c) 5 (d) 7
5. The ordered pair  $(x, y)$  satisfying  $1 - 2x - x^2 = \tan^2(x + y) + \cot^2(x + y)$  is  
 (a)  $\left(0, (2n+1)\frac{\pi}{4} + 1\right)$   
 (b)  $\left(1, (2n+1)\frac{\pi}{4} + 1\right)$   
 (c)  $\left(-1, (2n+1)\frac{\pi}{4} + 1\right)$   
 (d) None of these
6. The ordered pair  $(x, y)$  satisfying  $\frac{1 - \tan x}{1 + \tan x} = \tan y$  and  $x - y = \frac{\pi}{6}$  is  
 (a)  $\left(\frac{n\pi}{2} + \frac{\pi}{24}, \frac{n\pi}{2} + \frac{\pi}{24}\right), n \in \mathbb{Z}$   
 (b)  $\left(\frac{n\pi}{2} - \frac{5\pi}{24}, \frac{n\pi}{2} + \frac{\pi}{24}\right), n \in \mathbb{Z}$   
 (c)  $\left(\frac{n\pi}{2} + \frac{5\pi}{24}, \frac{n\pi}{2} - \frac{\pi}{24}\right), n \in \mathbb{Z}$   
 (d)  $\left(\frac{n\pi}{2} - \frac{5\pi}{24}, \frac{n\pi}{2} - \frac{\pi}{24}\right), n \in \mathbb{Z}$
7. The ordered pair  $(x, y)$  satisfying  $4 + \sin^2 x + \cos^2 x = 5 \sin^2 x \cdot \sin^2 y$  is  
 (a)  $\left(n\pi + \frac{\pi}{2}, n\pi + \frac{\pi}{2}\right), n \in \mathbb{Z}$   
 (b)  $\left(n\pi + \frac{\pi}{2}, m\pi - \frac{\pi}{2}\right), n, m \in \mathbb{Z}$   
 (c)  $\left(n\pi + \frac{\pi}{2}, m\pi + \frac{\pi}{2}\right), n, m \in \mathbb{Z}$   
 (d) None of these
8. The ordered pair  $(x, y)$  satisfying  $\sin^2 x = \sin y$  and  $\cos^4 x = \cos y$  is  
 (a)  $(n\pi, 2m\pi), n, m \in I$   
 (b)  $\left(n\pi + \frac{\pi}{2}, 2m\pi + \frac{\pi}{2}\right), n, m \in \mathbb{Z}$   
 (c)  $\left(n\pi, 2m\pi + \frac{\pi}{2}\right), n, m \in \mathbb{Z}$   
 (d)  $\left(n\pi + \frac{\pi}{2}, 2m\pi\right), n, m \in \mathbb{Z}$
9. The ordered pair  $(x, y)$  satisfying  $\sin^2 x + \sin^2 y = 3/4$  and  $x + y = \pi/3$  is  
 (a)  $(n\pi, -m\pi), n, m \in \mathbb{Z}$   
 (b)  $(n\pi + \pi/3, -m\pi), n, m \in \mathbb{Z}$   
 (c)  $(n\pi, m\pi + \pi/3), n, m \in \mathbb{Z}$   
 (d)  $(n\pi + \pi/6, m\pi + \pi/6), n, m \in \mathbb{Z}$

## Answer Keys

1. (c)    2. (b)    3. (a)    4. (b)    5. (c)    6. (a)    7. (c)    8. (a, b)    9. (b, c)

## PROBLEMS BASED ON EXTREME VALUES OF SIN X AND COS X

### Type I: Trigonometric equations involving single variable

**Step 1:** When LHS and RHS of equation have their ranges say  $R_1$  and  $R_2$  in common domain  $D$  and  $R_1 \cap R_2 = \phi$ , then the equations have no solution.

**Step 2:** If  $R_1 \cap R_2$  have finitely many elements and the number of elements are very few, then individual cases can be analysed and solved.

**ILLUSTRATION 49:** Solve for  $x$  :  $1 + \tan^4 x = \cos^6 x$

**SOLUTION:** RHS  $\in [0, 1] = R_1$ ; LHS  $\in [1, \infty) = R_2$ ;  $R_1 \cap R_2 = \{1\}$   
equality occurs iff  $\cos^6 x = 1 = 1 + \tan^4 x$ .  
 $\cos^6 x = 1$  and  $\tan^4 x = 0$ , possible only if  $x \in \{n\pi : n \in \mathbb{Z}\}$

**ILLUSTRATION 50:** Solve for  $x$  :  $3 \sin x = x^2 - 4x + 7$

**SOLUTION:**  $3 \sin x = x^2 - 4x + 7 \Rightarrow 3 \sin x = x^2 - 4x + 4 + 3$   
 $3 \sin x = (x - 2)^2 + 3$   
RHS  $\in [3, \infty) = R_2$ ; LHS  $\in [-3, 3) \Rightarrow R_1$ ;  $R_1 \cap R_2 = \{3\}$   
So, equality occurs iff  $x = 2$  and  $\sin x = 1$  which is impossible.

## Type II: Trigonometric equations involving more than one variables

To solve an equation involving more than one variable, definite solutions can be obtained if extreme values (range) of the functions are used.

**ILLUSTRATION 51:** To find  $x, y, z$  satisfying the equation  $\operatorname{cosec}^2 x + \sec^2 y + \sin^2 z = 2$

**SOLUTION:** Since  $\operatorname{cosec}^2 x \geq 1$  and  $\sec^2 y \geq 1$  and  $\sin^2 z \geq 0$   
 $\Rightarrow \operatorname{cosec}^2 x + \sec^2 y + \sin^2 z \geq 2$  So equality  $\underbrace{\operatorname{cosec}^2 x + \sec^2 y + \sin^2 z}_{\geq 2} = 2$

$$\text{holds iff } \begin{cases} \operatorname{cosec}^2 x = 1, \\ \sec^2 y = 1, \\ \sin^2 z = 0. \end{cases} \Rightarrow \begin{cases} \sin^2 x = 1 \Rightarrow x = (2n+1)\frac{\pi}{2} \\ \cos^2 y = 1 \Rightarrow y = m\pi \\ \sin^2 z = 0 \Rightarrow z = k\pi \end{cases}$$

Therefore G.S. is  $x = (2n+1)\frac{\pi}{2}, y = m\pi, z = k\pi, m, n, k \in \mathbb{Z}$

**ILLUSTRATION 52:** Solve  $\sin^4 x = 1 + \tan^8 x$

**SOLUTION:** L.H.S.  $\sin^4 x \leq 1$  and R.H.S.  $1 + \tan^8 x \geq 1$   
 $\Rightarrow$  L.H.S. = R.H.S. only when  $\sin^4 x = 1$  and  $1 + \tan^8 x = 1$   
 $\sin^2 x = 1$  and  $\tan^8 x = 0$   
which is never possible since  $\sin x$  and  $\tan x$  vanish simultaneously.  
Therefore the given equation has no solution.

**ILLUSTRATION 53:** Solve  $\sin^2 x + \cos^2 y = 2 \sec^2 z$

**SOLUTION:** L.H.S.  $= \sin^2 x + \cos^2 y \leq 2$  and R.H.S.  $= 2 \sec^2 z \geq 2$   
Hence L.H.S. and R.H.S. can be equal iff both are equal to two i.e., when  
 $\sin^2 x = 1, \cos^2 y = 1, \sec^2 z = 1$   
 $\Rightarrow \cos^2 x = 0, \sin^2 y = 0, \cos^2 z = 1 \Rightarrow \cos x = 0, \sin y = 0, \sin z = 0$   
 $\Rightarrow x = (2m+1)\frac{\pi}{2}, y = n\pi, z = t\pi$  where  $m, n, t$  are integers.

**ILLUSTRATION 54:** Find the solutions of the equation  $\sin x \cdot \sin 2x \cdot \sin 3x = 1$

**SOLUTION:**  $\sin x \cdot \sin 2x \cdot \sin 3x = 1$

Possible cases

**Case 1:**  $\sin x = 1$  and  $\sin 2x = -1$  and  $\sin 3x = -1$

or  $\sin x = \sin \pi/2$  and  $\sin 2x = \sin \frac{3\pi}{2}$  and  $\sin 3x = \sin \frac{3\pi}{2}$

or  $x = n\pi + (-1)^n \frac{\pi}{2}$  and  $x = \frac{n\pi}{2} + (-1)^n \frac{3\pi}{4}$  and  $x = \frac{n\pi}{3} + (-1)^n \frac{\pi}{2}$

there is no value of  $x$  which satisfies all equations simultaneously

**Case 2:**  $\sin x = -1$  and  $\sin 2x = 1$  and  $\sin 3x = -1$

or  $\sin x = \sin \frac{3\pi}{2}$  and  $\sin 2x = \sin \frac{\pi}{2}$  and  $\sin 3x = \sin \frac{3\pi}{2}$

or  $x = n\pi + (-1)^n \frac{3\pi}{2}$  and  $x = \frac{n\pi}{2} + (-1)^n \frac{3\pi}{4}$  and  $x = \frac{n\pi}{3} + (-1)^n \frac{\pi}{6}$

there is no value of  $x$  which satisfies all equations simultaneously.

**Case 3:**  $\sin x = -1$  and  $\sin 2x = -1$  and  $\sin 3x = 1$

or  $\sin x = \sin \frac{3\pi}{2}$  and  $\sin 2x = \sin \frac{3\pi}{2}$  and  $\sin 3x = \sin \frac{\pi}{2}$

or  $x = n\pi + (-1)^n \frac{3\pi}{2}$  and  $x = \frac{n\pi}{2} + (-1)^n \frac{3\pi}{4}$  and  $x = \frac{n\pi}{3} + (-1)^n \frac{\pi}{6}$

there is no value of  $x$  which satisfies all equations simultaneously.

**ILLUSTRATION 55:** Find the solutions of the equation  $\sin x \cdot \cos 4x \cdot \sin 5x = -1/2$

**SOLUTION:**  $\sin x \cdot \cos 4x \cdot \sin 5x = -1/2$

$(\sin x \cdot \sin 5x) \cdot \cos 4x = -1/2$

or  $2(\sin x \cdot \sin 5x) \cdot \cos 4x = -1$  or  $(\cos 4x - \cos 6x) \cos 4x = -1$

or  $\cos^2 4x - \cos 6x \cos 4x = -1$

or  $\frac{1 + \cos 8x}{2} - \left( \frac{\cos 10x + \cos 2x}{2} \right) = -1$  or  $\cos 8x - \cos 10x - \cos 2x = -3$

here only possible case is  $\begin{cases} \cos 8x = -1 \\ \cos 10x = 1 \\ \cos 2x = 1 \end{cases}$  which satisfies the equation.

But there is no value of  $x$  which gives  $\cos 8x = -1$ ,  $\cos 10x = 1$  and  $\cos 2x = 1$  simultaneously

## ■ TRANSCEDENTAL EQUATIONS

To solve the equation when the terms on the two sides (LHS and RHS) of the equation are of different nature e.g., trigonometric and algebraic, we use inequality method. Which is used to verify whether the given equation has any real solution or not. In this method, we follow the steps given below:

**Step I:** If given equation is  $f(x) = g(x)$ , then let  $y = f(x)$  and  $y = g(x)$  i.e., break the equation in two parts.

**Step II:** Find the extreme values of both sides of equation giving range of values of  $y$  for both sides. If there is any value of  $y$  satisfying both the inequalities, then there will be a real solution otherwise there will be no real solution.



**ILLUSTRATION 56:** Solve  $2 \cos^2 \frac{x}{2} \cdot \sin^2 x = x^2 + \frac{1}{x^2}$ ,  $0 < x \leq \pi/2$ .

**SOLUTION:** In this problem, terms on the two sides of the equation are different in nature.

L.H.S. is in trigonometric form, whereas R.H.S. is in algebraic form. Hence we will use inequality (extreme value) method.

$$\text{From L.H.S., } y = 2 \cos^2 \frac{x}{2} \cdot \sin^2 x \quad \dots(i)$$

$$= (1 + \cos x) \sin^2 x < 2 \quad \{\because 1 + \cos x < 2, \sin^2 x \leq 1\}$$

because (for  $0 < x \leq \pi/2$ ,  $0 \leq \cos x < 1$  and  $0 < \sin x \leq 1$ )

$$\text{i.e., } y < 2 \quad \dots(ii)$$

$$\text{From R.H.S } y = x^2 + \frac{1}{x^2} \geq 2 \quad \dots(iii)$$

$$\text{A.M.} \geq \text{G.M.} \Rightarrow \frac{x^2 + x^{-2}}{2} \geq \sqrt{x^2 x^{-2}}$$

$$\Rightarrow x^2 + y^2 \geq 2 \text{ i.e., } y \geq 2 \quad \dots(iv)$$

Evidently No value of  $y$  can be obtained satisfying (ii) and (iv) simultaneously

$\therefore$  no real solution of the equation exists.

**ILLUSTRATION 57:** Determine all the values of  $a$  for which the equation  $\cos^4 x - (a + 2) \cos^2 x - (a + 3) = 0$  possesses solution. Also, find the solutions.

**SOLUTION:**  $\cos^4 x - (a + 2) \cos^2 x - (a + 3) = 0$

$$\Rightarrow \cos^2 x = \frac{(a+2) \pm \sqrt{(a+2)^2 + 4(a+3)}}{2}$$

$$\Rightarrow \cos^2 x = \frac{(a+2) \pm (a+4)}{2}$$

$$\Rightarrow \text{either } \cos^2 x = -1 \text{ (not possible)}$$

$$\text{or } \cos^2 x = a + 3$$

$$\text{Since } 0 \leq \cos^2 x \leq 1 \Rightarrow 0 \leq a + 3 \leq 1 \Rightarrow -3 \leq a \leq -2 \text{ and } \cos^2 x = (a + 3)$$

$$\Rightarrow x = n\pi \pm \cos^{-1} \sqrt{a+3}$$

## TEXTUAL EXERCISE-11 (SUBJECTIVE)

1. Solve  $\sin^6 x = 1 + \cos^4 3x$ .

2. Solve  $2 \cos^2 \frac{x^2 + x}{6} = 2^x + 2^{-x}$ .

3. Solve  $\sin^2 x + \cos^2 y + \sin^2 z = 3 \operatorname{cosec}^2 u$ .

4. Solve the equation  $\cos^6 2x = 1 + \sin^4 x$ .

## Answer Keys

1.  $x = (2n + 1) \frac{\pi}{2}$ ,  $n \in \mathbb{Z}$       2.  $x = 0$

3.  $x = (2m + 1) \frac{\pi}{2}$ ,  $y = n\pi$ ,  $z = (2p + 1) \frac{\pi}{2}$ ;  $u = (2q + 1) \frac{\pi}{2}$  where  $m, n, p, q \in \mathbb{Z}$       4.  $x = n\pi$

**TEXTUAL EXERCISE-4 (OBJECTIVE)**

- The equation  $\sin x \cos x = 2$  has
  - One solution
  - Two solutions
  - Infinite solutions
  - No solutions
- The number of solutions of the equation  $2\cos(e^x) = 5^x + 5^{-x}$ , is
  - Zero
  - One
  - Two
  - Infinitely many
- The number of solutions of the equation  $2\cos(2n\pi x) = 5^x + 5^{-x}$ , where  $n \in \mathbb{Z}$  is
  - Zero
  - One
  - Two
  - Infinitely many
- The equation  $3 \cos x + 4 \sin x = 6$  has
  - Finitely many solutions
  - Infinite solutions
  - One solution
  - No solution
- The equation  $\sin x + \sin y + \sin z = -3$  for  $0 \leq x \leq 2\pi, 0 \leq y \leq 2\pi, 0 \leq z \leq 2\pi$ , has
  - One solution
  - Two sets of solutions
  - Four sets of solutions
  - No solution
- Number of solution of the equation  $2\sin x = 3x^2 + 2x + 3$  is
  - 0
  - 1
  - 2
  - 4
- Number of solution of the equation  $2\cos^2(x/2)\sin^2 x = x^2 + 1/x^2$  is
  - 0
  - 1
  - 2
  - 4
- The number of real solutions of  $2\cos(e^x) = x^2 + 2\sqrt{2}x + 4$  is
  - 1
  - 2
  - no solution
  - None of these
- The equation  $\sin^4 x = 1 + \tan^8 x$  has
  - infinitely many solutions
  - exactly one real solution
  - No solution
  - None of the above
- The equation  $\sin^2 x + \cos^2 y = 2 \sec^2 z$  has
  - exactly two real set of solutions
  - $x = (2m + 1) \frac{\pi}{2}, y = n\pi, z = t\pi; m, n, t \in \mathbb{Z}$
  - no solution
  - None of the above
- The real solutions of the equation  $\sin x \cos y = 1$  are
  - $x = (4m + 1) \frac{\pi}{2}, y = 2n\pi, m, n \in \mathbb{Z}$
  - $x = (2m + 1) \frac{\pi}{2}, y = n\pi, m, n \in \mathbb{Z}$
  - no solution
  - None of these
- Solution of the equation  $(\tan x)^{\cos^2 x} = (\cot x)^{\sin^2 x}$  is
  - $x = n\pi - \frac{\pi}{4}$  or  $x = n\pi + \frac{\pi}{4}$
  - $x = n\pi \pm \frac{\pi}{4}$
  - $x = n\pi + \pi/4$  or  $x = n\pi + (-1)^n \pi/2$
  - None of these
- Solution of the system of equations  $\tan^2 x + \cot^2 x = 2 \cos^2 y$  and  $\cos^2 y + \sin^2 z = 1$  is
  - $x = n\pi, y = m\pi, z = k\pi$  where  $k, m, n \in \mathbb{Z}$
  - $n = k\pi \pm \pi/4, y = m\pi, z = n\pi$  where  $k, m, n \in \mathbb{Z}$
  - no real solution
  - None of these
- Solution for  $x$  and  $y$  when  $x^2 + 2x \sin xy + 1 = 0$  is
  - $x = \pm 1, y = 2n\pi - \pi/2; n \in \mathbb{Z}$
  - $x = 1, y = 2n\pi, n \in \mathbb{Z}$
  - $x = -1, y = (2n + 1)\pi, n \in \mathbb{Z}$
  - None of these

**Answer Keys**

1. (d)    2. (a)    3. (b)    4. (d)    5. (a)    6. (a)    7. (a)    8. (c)    9. (c)    10. (b)  
 11. (a)    12. (c)    13. (b)    14. (a)

## GRAPHICAL SOLUTIONS OF EQUATIONS

For solution of equation  $f(x) - g(x) = 0$

Let  $\alpha$  is root.  $\Rightarrow f(\alpha) = g(\alpha) = k$ (say)

$\Rightarrow y = f(x)$  and  $y = g(x)$   
have same output for input  $x = \alpha$ .

$\Rightarrow (\alpha, k)$  satisfying both the curves  
 $y = f(x)$  and  $y = g(x)$ .

Solutions of equation  $f(x) - g(x) = 0$  are abscissa ( $x$  - co-ordinate) of the point of intersection of the graph  $y = f(x)$  and  $y = g(x)$ .

**Algorithm:** To solve the equation  $f(x) - g(x) = 0$   
e.g.,  $10\sin x - x = 0$

**Step 1:** Write the equation  $f(x) = g(x)$  i.e.,  $\sin x = x/10$ .

**Step 2:** Draw the graph of  $y = f(x)$  and  $y = g(x)$  on same  $x - y$  plane.

Let  $f(x) = \sin x$  and  $g(x) = \frac{x}{10}$

also we know that;  $-1 \leq \sin x \leq 1$

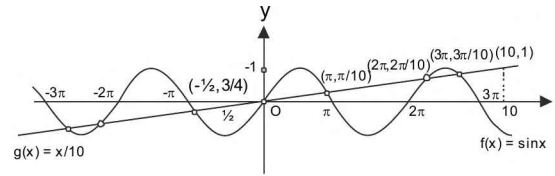

FIGURE 2.9

$$\therefore -1 \leq \frac{x}{10} \leq 1 \Rightarrow -10 \leq x \leq 10$$

Thus sketching both the curves when  $x \in [-10, 10]$ .

**Step 3:** Count the no. of the points of intersection. If graphs of  $y = f(x)$  and  $y = g(x)$  cuts at one, two, three, ..., no points, then number of solutions are one, two, three, ..., zero respectively.

From the given graph we can conclude that  $f(x) = \sin x$  and  $g(x) = \frac{x}{10}$  intersect at 7 points. So number of solutions are 7.

**ILLUSTRATION 58:** Find the number of solutions of the equation,  $\sin x = x^2 + x + 1$ .

**SOLUTION:** Let  $f(x) = \sin x$  and  $g(x) = x^2 + x + 1 = (x + 1/2)^2 + 3/4$   
which do not intersect at any point, Therefore no solution.

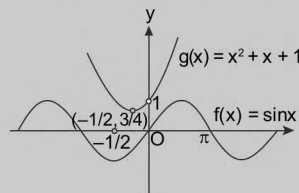

FIGURE 2.10

**ILLUSTRATION 59:** Find the number of roots of the equation  $\tan x = x + 1$  between  $-\pi/2$  and  $2\pi$ .

**SOLUTION:** This is also a problem of trigonometric form on LHS and algebraic form on R.H.S.

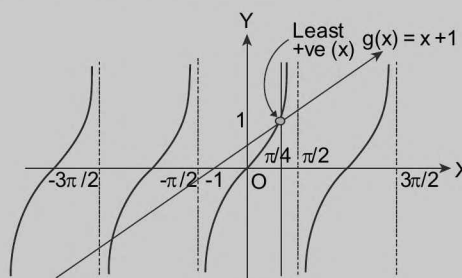

FIGURE 2.11

This can be solved by plotting the graph. Let  $y = \tan x$  and  $y = x + 1$ . Sketching both curves on same axes, we see that, the number of points of intersection is two. Hence number of solutions is 2.

**ILLUSTRATION 60:** Total number of solutions of the equation  $3x + 2 \tan x = \frac{5\pi}{2}$  in  $[0, 2\pi]$  is equal to

- (a) 1                      (b) 2                      (c) 3                      (d) 4

**SOLUTION:**  $3x + 2 \tan x = \frac{5\pi}{2} \Rightarrow \tan x = \frac{5\pi}{4} - \frac{3x}{2}$

Graphs of  $y = \frac{5\pi}{4} - \frac{3x}{2}$  and  $y = \tan x$ , meet exactly three times in  $[0, 2\pi]$ .

Thus number of solutions = 3.

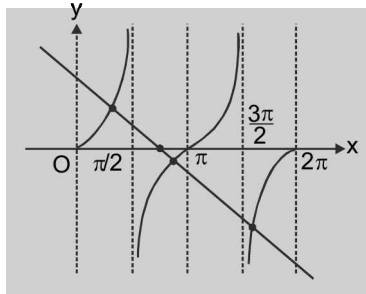

FIGURE 2.12

**ILLUSTRATION 61:** Total number of solutions of  $\sin \{x\} = \cos \{x\}$ , where  $\{ \cdot \}$  denotes the fractional part, in  $[0, 2\pi]$  is equal to

- (a) 3                      (b) 5                      (c) 7                      (d) None of these

**SOLUTION:**  $\sin \{x\} = \cos \{x\}$

Graphs of  $y = \sin \{x\}$  and  $y = \cos \{x\}$  meet exactly 7 times in  $[0, 2\pi]$

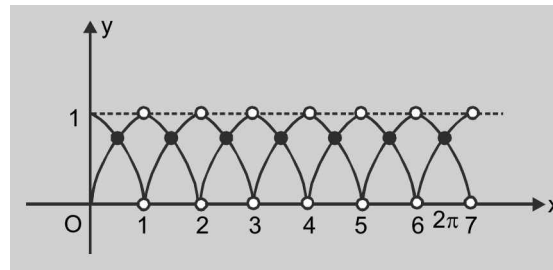

FIGURE 2.13

**ILLUSTRATION 62:** Total number of solutions of  $\cos 2x = |\sin x|$ , where  $X \in \left(-\frac{\pi}{2}, \pi\right)$  is

- (a) 3                      (b) 4                      (c) 5                      (d) 6

**SOLUTION: Method : 1** By case analysis

**Case (i):** When  $x \in \left(-\frac{\pi}{2}, 0\right)$ ;  $\sin x < 0 \Rightarrow |\sin x| = -\sin x$

$\therefore \cos 2x = -\sin x \Rightarrow 2\sin^2 x - \sin x - 1 = 0$

$\Rightarrow (\sin x - 1)(2\sin x + 1) = 0 \Rightarrow \sin x = 1$  or  $\sin x = -1/2$

$\Rightarrow x = -\pi/6$

**Case (ii)** when  $x \in [0, \pi)$ ;  $\sin x > 0$

$$\Rightarrow \cos 2x = \sin x \quad \Rightarrow 2\sin^2 x + \sin x - 1 = 0$$

$$\Rightarrow \sin x = -1 \text{ or } 1/2 \quad \Rightarrow x = \pi/6, 5\pi/6$$

$\therefore$  Total 3 solutions are there  $\Rightarrow$  (a) is correct

Method : 2 Graphically graph of  $y = \cos 2x$  and  $y = |\sin x|$  is as shown below in same x-y plane.

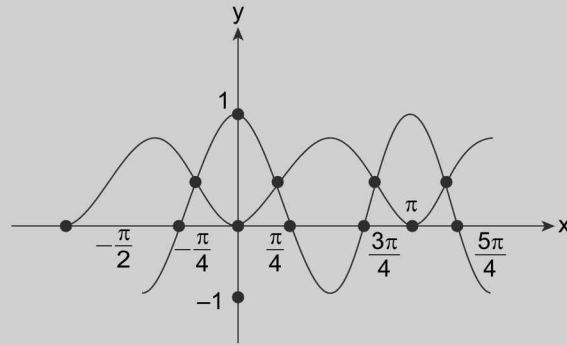

FIGURE 2.14

Clearly there are 3 points of intersection in  $\left(-\frac{\pi}{2}, \pi\right)$  corresponding to  $x = -\pi/6$ ,  $x = \pi/6$  and  $x = 5\pi/6$

$\therefore$  There will be 3 solutions

### TEXTUAL EXERCISE-5 (OBJECTIVE)

- Total number of solutions of  $\sin \pi x = |\ln |x||$  is  
 (a) 8 (b) 10  
 (c) 9 (d) 6
- Total number of solutions of  $\sin |\pi x| = |\ln |x||$  is  
 (a) 8 (b) 10  
 (c) 9 (d) 6
- Total number of solutions of  $|\sin \pi x| = |\ln |x||$  is  
 (a) 8 (b) 10  
 (c) 9 (d) 6
- Total number of solutions of  $\sin |\pi x| = |\ln |x||$  is  
 (a) 18 (b) 22  
 (c) 20 (d) 16
- The number of solutions of the equation:  $|\cos x| = [x]$ ,  
 (where  $[.]$  denotes the greatest integer function.  
 (a) Zero (b) infinitely many  
 (c) 4 (d) None of these
- The number of points of intersection of the two curves  
 $y = 2 \sin x$  and  $y = 5x^2 + 2x + 3$  is  
 (a) 0 (b) 1  
 (c) 2 (d)  $\infty$
- The number of solutions of  $\tan x \cdot \tan 4x = 1$   
 for  $0 < x < \pi$  is:  
 (a) 1 (b) 2  
 (c) 5 (d) 4
- If  $a, b \in [0, 2\pi]$  and the equation  $x^2 + 4 + 3 \sin(ax + b) - 2x = 0$  has atleast one solution, then  $(a + b) =$   
 (a)  $\frac{7\pi}{2}$  (b)  $\frac{5\pi}{2}$   
 (c)  $\frac{9\pi}{2}$  (d) None of these
- Total number of solutions of maximum  $(\sin x, \cos x) = \frac{1}{2}$  in  $(-2\pi, 5\pi)$  is equal to  
 (a) 3 (b) 5  
 (c) 7 (d) 9

10. Solutions of the equation  $|\cos x| = 2[x]$  are (where  $[ \ ]$  denotes the greatest integer Function)
- (a) Nil (b)  $x = \pi/3$   
 (c)  $x = \pm 1$  (d)  $x = 2\pi/3$
11. Total number of solution of  $\ln|\sin x| = -x^2 + 2x$  in  $\left[\frac{\pi}{2}, \frac{3\pi}{2}\right]$  is equal to
- (a) 1 (b) 2  
 (c) 4 (d) None of these

## Answer Keys

1. (d) 2. (a) 3. (b) 4. (c) 5. (a) 6. (a) 7. (d) 8. (a) 9. (c) 10. (a)  
 11. (a)

### ■ SOLVING INEQUALITIES

To solve trigonometric inequalities including trigonometric functions, it is good to practice periodicity and monotonicity

of functions. Thus, first solve the inequality for one period and then get the set of all solutions by adding numbers of the form  $2n\pi$ ;  $n \in \mathbb{Z}$  to each of the solutions obtained on that interval.

**ILLUSTRATION 63:** Find the solution set of inequality  $\sin x > 1/2$ .

**SOLUTION:** When  $\sin x = 1/2$ , the two values of  $x$  between 0 and  $2\pi$  are  $\pi/6$  and  $5\pi/6$  from the graph of  $y = \sin x$ , it is obvious that between 0 and  $2\pi$  (see figure 2.15)

$$\sin x > \frac{1}{2} \text{ for } \pi/6 < x < 5\pi/6$$

$$\text{Hence } \sin x > 1/2 \Rightarrow 2n\pi + \frac{\pi}{6} < x < 2n\pi + \frac{5\pi}{6}$$

$$\text{The required solution set is } \bigcup_{n \in \mathbb{Z}} \left( 2n\pi + \frac{\pi}{6}, 2n\pi + \frac{5\pi}{6} \right)$$

**ILLUSTRATION 64:** If  $0 < \theta < 2\pi$ , then the intervals of values of  $\theta$  for which  $2 \sin^2 \theta - 5 \sin \theta + 2 > 0$ , is

- (a)  $\left(0, \frac{\pi}{6}\right) \cup \left(\frac{5\pi}{6}, 2\pi\right)$  (b)  $\left(\frac{\pi}{8}, \frac{5\pi}{6}\right)$   
 (c)  $\left(0, \frac{\pi}{8}\right) \cup \left(\frac{\pi}{6}, \frac{5\pi}{6}\right)$  (d)  $\left(\frac{41\pi}{48}, \pi\right)$

**SOLUTION:** Since,  $2 \sin^2 \theta - 5 \sin \theta + 2 > 0 \Rightarrow (2 \sin \theta - 1)(\sin \theta - 2) > 0$   
 [where,  $(\sin \theta - 2) < 0$  for all  $\theta \in \mathbb{R}$ ]

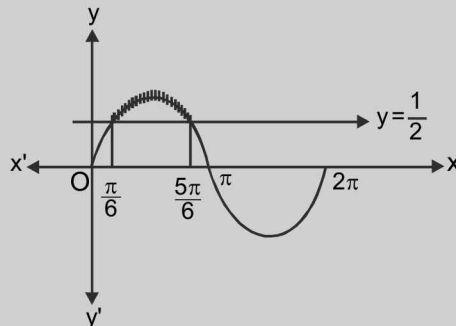

FIGURE 2.15

$$\therefore (2 \sin \theta - 1) < 0 \Rightarrow \sin \theta < \frac{1}{2}$$

$$\therefore \text{From the graph, } \theta \in \left(0, \frac{\pi}{6}\right) \cup \left(\frac{5\pi}{6}, 2\pi\right)$$

**ILLUSTRATION 65:** Solve the inequality  $\sin 2x > \sqrt{2} \sin^2 x + (2 - \sqrt{2}) \cos^2 x$ .

**SOLUTION:**  $\sin 2x > \sqrt{2} \sin^2 x + (2 - \sqrt{2}) \cos^2 x$

$$2 \sin x \cos x > \sqrt{2} \sin^2 x + (2 - \sqrt{2}) \cos^2 x$$

$$\text{or } \sqrt{2} \tan^2 x - 2 \tan x + (2 - \sqrt{2}) < 0$$

$$\text{or } \tan x = \frac{2 \pm \sqrt{4 - 4(\sqrt{2})(2 - \sqrt{2})}}{2\sqrt{2}} = \frac{2 \pm \sqrt{4 - 8\sqrt{2} + 8}}{2\sqrt{2}}$$

$$= \frac{2 \pm \sqrt{2^2 - 2 \cdot 2 \cdot \sqrt{2} + (2\sqrt{2})^2}}{2\sqrt{2}} = \frac{2 \pm \sqrt{(2\sqrt{2} - 2)^2}}{2\sqrt{2}} = \frac{2 \pm (2\sqrt{2} - 2)}{2\sqrt{2}} = \sqrt{2} - 1, 1$$

$$\tan x \in (\sqrt{2} - 1, 1) \text{ or } x \in \left(n\pi + \frac{\pi}{8}, n\pi + \frac{\pi}{4}\right); n \in \mathbb{Z}$$

**ILLUSTRATION 66:** Solve the inequality:  $\sin x \cos x + \frac{1}{2} (\tan x) \geq 1$ .

**SOLUTION:** Here, left hand side is defined for all  $x$ , except  $x = n\pi + \frac{\pi}{2}$  where  $n \in \mathbb{Z}$

$$\Rightarrow 2 \sin x \cos x + \tan x \geq 2 \Rightarrow \frac{2y}{1+y^2} + y \geq 2; \text{ where } y = \tan x$$

$$\Rightarrow \frac{2y + y(1+y^2) - 2(1+y^2)}{(1+y^2)} \geq 0$$

$$\therefore 2y + y(1+y^2) - 2(1+y^2) \geq 0 \Rightarrow y^3 - 2y^2 + 3y - 2 \geq 0$$

$$\Rightarrow y^2(y-1) - y(y-1) + 2(y-1) \geq 0 \text{ or } (y-1)(y^2 - y + 2) \geq 0$$

$$\Rightarrow y \geq 1 \left\{ \because y^2 - y + 2 = \left(y - \frac{1}{2}\right)^2 + \frac{7}{4} > 0, \text{ for all } y \right\}$$

$\therefore \tan x \geq 1$ , shown in figure given below

$$\Rightarrow \frac{\pi}{4} \leq x < \frac{\pi}{2} \text{ in a solution in } \left(-\frac{\pi}{2}, \frac{\pi}{2}\right)$$

$$\Rightarrow n\pi + \frac{\pi}{4} \leq x < n\pi + \frac{\pi}{2}; n \in \mathbb{Z} \text{ i.e., } x \in \left[n\pi + \frac{\pi}{4}, n\pi + \frac{\pi}{2}\right); n \in \mathbb{Z} \text{ is the general solution.}$$

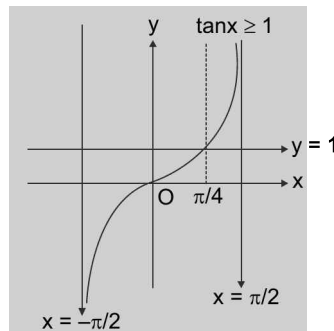

FIGURE 2.16

**TEXTUAL EXERCISE-12 (SUBJECTIVE)**

- Find the solution set for  $2 \sin^2 x - 3 \sin x + 1 \leq 0$  when  $x \in [0, 2\pi]$ .
- Solve the following inequalities:
  - $\cos x \leq -1/2$
  - $\sin x \geq -1/2$
  - $\tan x > -\sqrt{3}$
  - $\sin x + \sqrt{3} \cos x \geq 0$
- Prove that  $0 \leq \frac{1 + \cos \theta}{2 + \cos \theta} \leq \frac{2}{3}$  for all  $\theta$ .
- Solve the following inequalities:
  - $\sin x + \cos x < \frac{1}{\sin x}$
  - $\cos 3x + \sqrt{3} \sin 3x < -\sqrt{2}$
  - $5 \sin^2 x - 3 \sin x \cos x - 36 \cos^2 x > 0$
  - $\sin 4x + \cos 4x \cot 2x > 1$
- Solve the following inequalities:
  - $6 \sin^2 x - \sin x \cos x - \cos^2 x > 2$
  - $\cos^2 x \geq 1/2$
  - $2 \sin^2 x/2 + \cos 2x < 0$
  - $\cos^2 x + 3 \sin^2 x + 2 \sqrt{3} \sin x \cos x < 1$
  - $\sin^6 x + \cos^6 x < 7/16$

**Answer Keys**

- $\frac{\pi}{6} \leq x \leq \frac{5\pi}{6}$
- $\bigcup_{n \in \mathbb{Z}} \left[ 2n\pi + \frac{2\pi}{3}, 2n\pi + \frac{4\pi}{3} \right]$
  - $\bigcup_{n \in \mathbb{Z}} \left[ 2n\pi - \frac{\pi}{6}, 2n\pi + \frac{7\pi}{6} \right]$
  - $\bigcup_{n \in \mathbb{Z}} \left[ n\pi - \frac{\pi}{3}, n\pi + \frac{\pi}{2} \right]$
  - $\bigcup_{n \in \mathbb{Z}} \left[ (6n-1)\frac{\pi}{3}, 2(3n+1)\frac{\pi}{3} \right]$
- $2n\pi + 5\pi/4 < x < 2n\pi + 3\pi/2; 2n\pi < x < 2n\pi + \pi/4; 2n\pi + \pi/2 < x < (2n+1)\pi$
  - $\frac{2n\pi}{3} + \frac{13\pi}{36} < x < \frac{2n\pi}{3} + \frac{19\pi}{36}$
  - $n\pi + \cot^{-1} \frac{1}{3} < x < n\pi + \cot^{-1} \left( -\frac{5}{12} \right)$
  - $\frac{n\pi}{2} < x < \frac{n\pi}{2} + \frac{\pi}{8}$
- $n\pi + \pi/4 < x < n\pi + \cot^{-1}(-4/3)$
  - $-\sqrt{\frac{\pi}{3}} \leq x \leq \sqrt{\frac{\pi}{3}}; \sqrt{2n\pi - \frac{\pi}{3}} \leq x \leq \sqrt{2n\pi + \frac{\pi}{3}}; -\sqrt{2n\pi + \frac{\pi}{3}} \leq x \leq -\sqrt{2n\pi - \frac{\pi}{3}}$  where  $n \in \mathbb{N}$
  - $2n\pi - \frac{\pi}{2} < x < 2n\pi - \frac{\pi}{3}; 2n\pi + \frac{\pi}{3} < x < 2n\pi + \frac{\pi}{2}$
  - $n\pi - \frac{\pi}{3} < x < n\pi$
  - $\frac{n\pi}{2} + \frac{\pi}{6} < x < \frac{n\pi}{2} + \frac{\pi}{3}$

**TEXTUAL EXERCISE-6 (OBJECTIVE)**

- Solution of the inequality  $\sin x > 1/\sqrt{2}$  belongs to
  - $\left( 2n\pi + \frac{\pi}{4}, 2n\pi + \frac{3\pi}{4} \right)$  where  $n \in \mathbb{Z}$
  - $\left( 2n\pi - \frac{3\pi}{4}, 2n\pi - \frac{\pi}{4} \right)$  where  $n \in \mathbb{Z}$
  - $\left( 2n\pi + \frac{\pi}{4}, 2n\pi + \frac{\pi}{2} \right)$  where  $n \in \mathbb{Z}$
  - None of these



2.44 > Trigonometry

2. All solutions of the inequality  $\cos x \geq -\sqrt{3}/2$  belongs to

- (a)  $\left(2n\pi + \frac{\pi}{6}, 2n\pi + \frac{5\pi}{6}\right)$ ; where  $n = 0, 1, 2, \dots$   
 (b)  $\left[2n\pi - \frac{5\pi}{6}, 2n\pi + \frac{5\pi}{6}\right]$ ; where  $n = 0, 1, 2, \dots$   
 (c)  $\left(2n\pi - \frac{5\pi}{6}, 2n\pi + \frac{5\pi}{6}\right)$ ; where  $n = 0, 1, 2, \dots$   
 (d) None of these

3. The solution set of inequality  $\cos x \geq -\frac{1}{2}$  is

- (a)  $\bigcup_{n \in \mathbb{Z}} \left[2n\pi - \frac{2\pi}{3}, 2n\pi + \frac{2\pi}{3}\right]$   
 (b)  $\bigcup_{n \in \mathbb{Z}} \left(n\pi - \frac{2\pi}{3}, n\pi + \frac{2\pi}{3}\right)$   
 (c)  $\bigcup_{n \in \mathbb{Z}} \left(2n\pi - \frac{2\pi}{3}, n\pi - \frac{\pi}{3}\right)$   
 (d) None of these

4. If  $2\cos x < \sqrt{3}$  and  $x \in [-\pi, \pi]$ , then the solution set for  $x$  is

- (a)  $\left[-\pi, -\frac{\pi}{6}\right) \cup \left(\frac{\pi}{6}, \pi\right]$   
 (b)  $\left(-\frac{\pi}{6}, \frac{\pi}{6}\right)$   
 (c)  $\left[-\pi, -\frac{\pi}{6}\right] \cup \left[\frac{\pi}{6}, \pi\right]$   
 (d) None of these

5. Solution set of the inequality  $|\tan x| < 1/\sqrt{3}$  is

- (a)  $\left(n\pi - \frac{\pi}{6}, n\pi + \frac{\pi}{6}\right)$ ;  $n \in \mathbb{Z}$   
 (b)  $\left(n\pi - \frac{\pi}{3}, n\pi + \frac{\pi}{3}\right)$ ;  $n \in \mathbb{Z}$   
 (c)  $\left(n\pi - \frac{2\pi}{3}, n\pi + \frac{2\pi}{3}\right)$ ;  $n \in \mathbb{Z}$   
 (d) None of these

6. If  $|\tan x| \leq 1$  and  $x \in [-\pi, \pi]$ , then the solution set for  $x$  is:

- (a)  $\left[-\pi, -\frac{3\pi}{4}\right] \cup \left[-\frac{\pi}{4}, \frac{\pi}{4}\right] \cup \left[\frac{3\pi}{4}, \pi\right]$   
 (b)  $\left[-\frac{\pi}{4}, \frac{\pi}{4}\right] \cup \left[\frac{3\pi}{4}, \pi\right]$   
 (c)  $\left[-\frac{\pi}{4}, \frac{\pi}{4}\right]$   
 (d) None of these

7. If  $\cos x - \sin x \geq 1$  and  $0 \leq x \leq 2\pi$ , then the solution set for  $x$  is

- (a)  $\left[0, \frac{\pi}{4}\right] \cup \left[\frac{7\pi}{4}, 2\pi\right]$   
 (b)  $\left[\frac{3\pi}{2}, \frac{7\pi}{4}\right] \cup \{0\}$   
 (c)  $\left[\frac{3\pi}{2}, 2\pi\right] \cup \{0\}$   
 (d) None of these

8. The solution set of the inequality  $\cos^2 \theta < \frac{1}{2}$  is

- (a)  $\left\{\theta : (8n+1)\frac{\pi}{4} < \theta < (8n+3)\frac{\pi}{4}, n \in \mathbb{Z}\right\}$   
 (b)  $\left\{\theta : (8n-3)\frac{\pi}{4} < \theta < (8n-1)\frac{\pi}{4}, n \in \mathbb{Z}\right\}$   
 (c)  $\left\{\theta : (4n+1)\frac{\pi}{4} < \theta < (4n+3)\frac{\pi}{4}, n \in \mathbb{Z}\right\}$   
 (d) None of these

9. If  $4 \sin^2 x - 8 \sin x + 3 \leq 0$ ,  $0 \leq x \leq 2\pi$ , then the solution set for  $x$  is

- (a)  $\left[0, \frac{\pi}{6}\right]$  (b)  $\left[0, \frac{5\pi}{6}\right]$   
 (c)  $\left[\frac{5\pi}{6}, 2\pi\right]$  (d)  $\left[\frac{\pi}{6}, \frac{5\pi}{6}\right]$

10. The set of values of  $x$  for which  $\sin x \cdot \cos^3 x > \cos x$ .  $\sin^3 x$ ,  $0 \leq x \leq 2\pi$  is:

- (a)  $(0, \pi)$   
 (b)  $\left(0, \frac{\pi}{4}\right)$   
 (c)  $\left(\frac{\pi}{4}, \pi\right)$   
 (d) None of these

## Answer Keys

1. (a)    2. (b)    3. (a)    4. (a)    5. (a)    6. (a)    7. (c)    8. (c)    9. (d)    10. (b)

### Review of Some Important Trigonometric Values

S.No.	Angle	Value	S.No.	Angle	Value
1.	$\sin 15^\circ$	$\frac{\sqrt{3}-1}{2\sqrt{2}}$	2.	$\cos 15^\circ$	$\frac{\sqrt{3}+1}{2\sqrt{2}}$
3.	$\tan 15^\circ$	$2-\sqrt{3} = \cot 75^\circ$	4.	$\cot 15^\circ$	$2+\sqrt{3} = \tan 75^\circ$
5.	$\sin 22\frac{1}{2}^\circ$	$\frac{1}{2}(\sqrt{2}-\sqrt{2})$	6.	$\cos 22\frac{1}{2}^\circ$	$\frac{1}{2}(\sqrt{2}+\sqrt{2})$
7.	$\tan 22\frac{1}{2}^\circ$	$\sqrt{2}-1$	7.	$\cot 22\frac{1}{2}^\circ$	$\sqrt{2}+1$
9.	$\sin 18^\circ$	$\frac{\sqrt{5}-1}{4} = \cos 72^\circ$	10.	$\cos 18^\circ$	$\frac{\sqrt{10+2\sqrt{5}}}{4} = \sin 72^\circ$
11.	$\sin 36^\circ$	$\frac{\sqrt{10-2\sqrt{5}}}{4} = \cos 54^\circ$	12.	$\cos 36^\circ$	$\frac{\sqrt{5}+1}{4} = \sin 54^\circ$
13.	$\sin 9^\circ$	$\frac{\sqrt{3+\sqrt{5}}-\sqrt{5-\sqrt{5}}}{4}$ or $\cos 81^\circ$	14.	$\cos 9^\circ$	$\frac{\sqrt{3+\sqrt{5}}+\sqrt{5-\sqrt{5}}}{4}$ or $\sin 81^\circ$
15.	$\cos 36^\circ - \cos 72^\circ$	1/2	16.	$\cos 36^\circ \cdot \cos 72^\circ$	1/4

## MULTIPLE CHOICE QUESTIONS

### SECTION-I

#### SOLVED SUBJECTIVE QUESTIONS

1. Solve the following equations for  $x$  and  $y$

$$|\sin x + \cos x|^{\sin^2 x - 1/4} = 1 + |\sin y| \text{ and } \cos^2 y = 1 + \sin^2 y.$$

**Solution:** Given equations are

$$|\sin x + \cos x|^{\sin^2 x - 1/4} = 1 + |\sin y| \quad \dots\dots(1)$$

$$\text{and } \cos^2 y = 1 + \sin^2 y \quad \dots\dots(2)$$

$$\text{Now, equation (2)} \Rightarrow 1 - \sin^2 y = 1 + \sin^2 y$$

$$\Rightarrow \sin y = 0; y = p\pi, p \in \mathbb{Z} \quad \dots(3)$$

$$\Rightarrow |\sin x + \cos x|^{\sin^2 x - 1/4} = 1$$

Then either  $\sin^2 x = 1/4$  or  $\sin x + \cos x = 1$

$$\Rightarrow x = k\pi \pm \pi/6 \text{ or } \cos\left(x - \frac{\pi}{4}\right) = \cos\frac{\pi}{4}$$

$$\Rightarrow x - \frac{\pi}{4} = 2m\pi \pm \frac{\pi}{4} \Rightarrow x = 2m\pi + \frac{\pi}{2}; \text{ or } x = 2n\pi$$

Thus  $x = 2m\pi + \frac{\pi}{2}; 2n\pi$  or  $k\pi \pm \frac{\pi}{6}$  and  $y = p\pi, m, n, p, k \in \mathbb{Z}$ .

2. Consider the system of linear equations in  $x, y$  and  $z$ :

$$(\sin 3\theta)x - y + z = 0$$

$$(\cos 2\theta)x + 4y + 3z = 0$$

$$2x + 7y + 7z = 0$$

Find the values of  $\theta$  for which the system has non-trivial solution.

**Solution:** Since the system has non-trivial solutions, the determinant of coefficients = 0

$$\therefore \begin{vmatrix} \sin 3\theta & -1 & 1 \\ \cos 2\theta & 4 & 3 \\ 2 & 7 & 7 \end{vmatrix} = 0$$

$$\text{or } (\sin 3\theta)(28 - 21) - \cos 2\theta(-7 - 7) + 2(-3 - 4) = 0$$

$$\text{or } \sin 3\theta + 2 \cos 2\theta - 2 = 0$$

$$\text{or } (3\sin \theta - 4\sin^3 \theta) + 2(1 - 2 \sin^2 \theta) - 2 = 0$$

$$\text{or } 4 \sin^3 \theta + 4 \sin^2 \theta - 3 \sin \theta = 0$$

$$\text{or } \sin \theta(2 \sin \theta - 1)(2 \sin \theta + 3) = 0$$

$$\therefore \sin \theta = 0 \text{ or } \sin \theta = 1/2 \quad (\because \sin \theta \neq -3/2)$$

If  $\sin \theta = 0$ , then  $\theta = n\pi, \forall n \in \mathbb{Z}$

And if  $\sin \theta = 1/2 = \sin(\pi/6)$ ,

then  $\theta = n\pi + (-1)^n \pi/6, \forall n \in \mathbb{Z}$

Hence the required values of  $\theta$  are

$$\theta = n\pi, n\pi + (-1)^n \pi/6, \forall n \in \mathbb{Z}$$

3. Solve the equations for  $x$ ,

$$5^{\frac{1}{2}} + 5^{\frac{1}{2} + \log_5(\sin x)} = 15^{\frac{1}{2} + \log_{15} \cos x}$$

$$\text{Solution: } 5^{\frac{1}{2}} + 5^{\frac{1}{2} + \log_5(\sin x)} = 15^{\frac{1}{2} + \log_{15} \cos x}$$

$$\Rightarrow 5^{\frac{1}{2}} + 5^{\frac{1}{2}} \cdot 5^{\log_5(\sin x)} = 15^{1/2} \cdot 15^{\log_{15} \cos x}$$

$$\Rightarrow 5^{1/2} + 5^{1/2} \cdot \sin x = 15^{1/2} \cdot \cos x$$

$$\Rightarrow 1 + \sin x = \sqrt{3} \cos x \Rightarrow \frac{\sqrt{3}}{2} \cos x - \frac{\sin x}{2} = \frac{1}{2}$$

$$\Rightarrow \cos\left(x + \frac{\pi}{6}\right) = \cos\frac{\pi}{3} \text{ or } x + \frac{\pi}{6} = 2n\pi \pm \frac{\pi}{3}$$

$$\text{or } x = 2n\pi - \frac{\pi}{2}, 2n\pi + \frac{\pi}{6}$$

$$\text{but } x \in \left(2n\pi, 2n\pi + \frac{\pi}{2}\right) \begin{cases} \because \sin x > 0 \\ \text{and } \cos x > 0 \end{cases}$$

$$\therefore x = 2n\pi + \pi/6; n \in \mathbb{Z}$$

4. Find the general solution of the equation,  $2 + \tan x \cdot \cot$

$$\frac{x}{2} + \cot x \cdot \tan \frac{x}{2} = 0$$

$$\text{Solution: } 2 + \tan x \cdot \cot \frac{x}{2} + \cot x \cdot \tan \frac{x}{2} = 0 \quad \dots(1)$$

$$\text{let } \tan x \cdot \cot \frac{x}{2} = y,$$

$$\text{then equation (1) becomes } 2 + \left(y + \frac{1}{y}\right) = 0$$

$$\Rightarrow y + \frac{1}{y} = -2,$$

Solving, we get,  $y = -1$

$$\text{or } \tan x \cdot \cot \frac{x}{2} = -1 \text{ or } \frac{\sin x}{\cos x} \cdot \frac{\cos \frac{x}{2}}{\sin \frac{x}{2}} = -1$$

$$\text{or } \frac{2 \sin \frac{x}{2} \cos \frac{x}{2} \cos \frac{x}{2}}{\cos x \sin \frac{x}{2}} = -1$$

$$\text{or } \frac{2 \cos^2 \frac{x}{2}}{\cos x} = -1 \text{ or } \frac{1 + \cos x}{\cos x} = -1$$

$$\text{or } \cos x = -\frac{x}{2} \text{ or } x = 2n\pi \pm \frac{2\pi}{3}$$

5. Find the general solution of the trigonometric

$$\text{equation } 3^{\left(\frac{1}{2} + \log_3(\cos x + \sin x)\right)} - 2^{\log_2(\cos x - \sin x)} = \sqrt{2}.$$

$$\text{Solution: } 3^{\left(\frac{1}{2} + \log_3(\cos x + \sin x)\right)} - 2^{\log_2(\cos x - \sin x)} = \sqrt{2}$$

$$\text{or } \sqrt{3} (\cos x + \sin x) - (\cos x - \sin x) = \sqrt{2}$$

$$\text{or } \sqrt{3} \cos x + \sqrt{3} \sin x - \cos x + \sin x = \sqrt{2}$$

$$\text{or } (\sqrt{3} + 1) \sin x + (\sqrt{3} - 1) \cos x = \frac{2\sqrt{2}}{2}$$

$$\text{or } \left(\frac{\sqrt{3}+1}{2\sqrt{2}}\right) \sin x + \left(\frac{\sqrt{3}-1}{2\sqrt{2}}\right) \cos x = \frac{1}{2}$$

$$\text{or } \cos(x - 75^\circ) = \cos \frac{\pi}{3} \text{ or } x - 75^\circ = 2n\pi \pm \frac{\pi}{3}$$

$$\text{or } x = 2n\pi \pm \frac{\pi}{3} + \frac{5\pi}{12} \text{ or } x = 2n\pi + \frac{3\pi}{4}, 2n\pi + \frac{\pi}{12}; n \in \mathbb{Z}$$

6. Find the range of  $y$  such that the equation,  $y + \cos x = \sin x$  has a real solution. For  $y = 1$ , find  $x$  such that  $0 < x < 2\pi$ .

$$\text{Solution: } y + \cos x = \sin x$$

$$y = \sin x - \cos x$$

$$= \sqrt{2} \left[ \frac{1}{\sqrt{2}} \sin x - \frac{1}{\sqrt{2}} \cos x \right] = -\sqrt{2} \sin \left( \frac{\pi}{4} - x \right)$$

$$y \in [-\sqrt{2}, \sqrt{2}]$$

$$\therefore \text{ we have, } y = -\sqrt{2} \sin \left( \frac{\pi}{4} - x \right) \text{ for } y = 1;$$

$$1 = -\sqrt{2} \left[ \sin \frac{\pi}{4} \cos x - \cos \frac{\pi}{4} \sin x \right]$$

$$\Rightarrow \frac{1}{\sqrt{2}} = \sin \left( x - \frac{\pi}{4} \right)$$

$$\Rightarrow \sin \left( x - \frac{\pi}{4} \right) = \sin \left( \frac{\pi}{4} \right)$$

$$\Rightarrow x = 2m\pi + \frac{\pi}{2} \text{ or } (2k+1)\pi; m, k \in \mathbb{Z}$$

$$\text{But } 0 < x < 2\pi \Rightarrow x = \frac{\pi}{2}, \pi$$

7. Find the solution set of the equation,

$$\log_{\frac{-x^2-6x}{10}} (\sin 3x + \sin x) = \log_{\frac{-x^2-6x}{10}} (\sin 2x).$$

$$\text{Solution: } \log_{\frac{-x^2-6x}{10}} (\sin 3x + \sin x) = \log_{\frac{-x^2-6x}{10}} (\sin 2x)$$

$$\Rightarrow \sin 3x + \sin x > 0 \text{ and } \sin 2x > 0$$

$$\Rightarrow 2 \sin 2x \cos x > 0 \text{ and}$$

$$\Rightarrow x \in (2n\pi, (2n+1)\pi)$$

$$\text{Now, } \log_{\frac{-x^2-6x}{10}} \left( \frac{\sin 3x + \sin x}{\sin 2x} \right) = 0 \text{ (By given equation)}$$

$$\Rightarrow \frac{2 \sin 2x \cos x}{\sin 2x} = 1$$

$$\Rightarrow 2 \cos x = 1$$

$$\Rightarrow \cos x = 1/2 \Rightarrow x = 2n\pi \pm \pi/3$$

$$\Rightarrow x \in (-6, 0) \left( \because \frac{-x^2-6x}{10} > 0 \text{ and } \frac{-x^2-6x}{10} \neq 1 \right)$$

$$\text{Also } x \in (2n\pi, (2n+1)\pi) \Rightarrow x \in (-2\pi, -\pi)$$

$$\therefore \text{ for } n = -1 \Rightarrow x = -2\pi + \pi/3 = -\frac{5\pi}{3}$$

8. Find all the solutions of the equation

$$\sin x + \sin y = \sin(x+y), |x| + |y| = 1.$$

$$\text{Solution: } \sin x + \sin y = \sin(x+y), |x| + |y| = 1$$

$$\Rightarrow 2 \sin \frac{x+y}{2} \left[ \cos \frac{x-y}{2} - \cos \frac{x+y}{2} \right] = 0$$

$$\Rightarrow 4 \sin \frac{x+y}{2} \sin \frac{x}{2} \sin \frac{y}{2} = 0$$

$$\text{(i) } \sin \frac{x+y}{2} = 0 \Rightarrow (x+y) = 2n\pi, n \in \mathbb{Z} \quad \dots (1)$$

$$\text{as } x, y \in [-1, 1]$$

$$\Rightarrow x+y \in [-2, 2] \Rightarrow x+y=0 \Rightarrow y=-x$$

$$\text{(ii) } \sin \frac{x}{2} = 0 \Rightarrow x = 2m\pi, \text{ where } m \in \mathbb{Z} \quad \dots (2)$$

$$\Rightarrow x=0 \text{ as } |x| \leq 1 \Rightarrow -1 \leq x \leq 1$$

$$\text{(iii) } \sin \frac{y}{2} = 0 \Rightarrow y = 2p\pi, p \in \mathbb{Z} \quad \dots (3)$$

$$\Rightarrow y=0 \text{ as } |x| + |y| = 1 \Rightarrow |y| \leq 1 \Rightarrow -1 \leq y \leq 1$$

$$|x| + |y| = 1 \Rightarrow x+y=1 \text{ or}$$

$$x-y=1 \text{ or } -x+y=1 \text{ or } -x-y=1$$

2.48 > Trigonometry

Simultaneously solving the above equations, we get the solutions and the solutions are (0, 1), (0, -1),

$$(1, 0), (-1, 0), \left(\frac{1}{2}, -\frac{1}{2}\right) \text{ and } \left(\frac{1}{2}, -\frac{1}{2}\right)$$

9. Find all the solutions of the equation  $4^{\sin x} + 3^{\sec y} = 11$  and  $5.16^{\sin x} - 2.3^{\sec y} = 2$ .

**Solution:**  $4^{\sin x} + 3^{\sec y} = 11$  ... (1)

$5.16^{\sin x} - 2.3^{\sec y} = 2$  ... (2)

Multiplying equation (1) by 2 and adding to it equation (2),

$$\Rightarrow 2.4^{\sin x} + 5.16^{\sin x} = 24$$

Let  $4^{\sin x} = t$

$$5t^2 + 2t - 24 = 0$$

$$\Rightarrow t(5t + 12) - 2(5t + 12) = 0$$

$$\Rightarrow t = -\frac{12}{5} \text{ or } 2; \text{ as } t > 0 \Rightarrow t = 2$$

$$4^{\sin x} = 2 \Rightarrow \sin x = 1/2 \Rightarrow x = n\pi + (-1)^n \frac{\pi}{6}; n \in \mathbb{Z}$$

also from (1), when  $\sin x = 1/2$ ;  $3^{\sec y} = 3^2 \Rightarrow \cos y = 1/2$

$$\Rightarrow y = 2m\pi \pm \frac{\pi}{3}; m \in \mathbb{Z}$$

10. Solve:  $\sin\left(\frac{\sqrt{x}}{2}\right) + \cos\left(\frac{\sqrt{x}}{2}\right) = \sqrt{2} \sin \sqrt{x}$ .

**Solution: Method (1)**

$$\sin\left(\frac{\sqrt{x}}{2}\right) + \cos\left(\frac{\sqrt{x}}{2}\right) = \sqrt{2} \sin \sqrt{x}$$

$$\Rightarrow 1 + 2 \sin \frac{\sqrt{x}}{2} \cos \frac{\sqrt{x}}{2} = 2 \sin^2 \sqrt{x}$$

$$\Rightarrow 1 + \sin \sqrt{x} = 2 \sin^2 \sqrt{x}$$

$$\Rightarrow 2 \sin^2 \sqrt{x} - \sin \sqrt{x} - 1 = 0$$

$$\Rightarrow 2 \sin^2 \sqrt{x} - 2 \sin \sqrt{x} + \sin \sqrt{x} - 1 = 0$$

$$\Rightarrow 2 \sin \sqrt{x} (\sin \sqrt{x} - 1) + 1(\sin \sqrt{x} - 1) = 0$$

$$\Rightarrow \sin \sqrt{x} = -\frac{1}{2} \text{ or } \sin \sqrt{x} = 1$$

$$\Rightarrow \sqrt{x} = n\pi + (-1)^n \left(\frac{-\pi}{6}\right); \sqrt{x} = n\pi + (-1)^n \frac{\pi}{2}$$

$$x = \left(n\pi + (-1)^{n+1} \frac{\pi}{6}\right)^2 \text{ or } x = \left(n\pi + (-1)^n \frac{\pi}{2}\right)^2$$

**Method (2):**

In cos form, we get the equation

$$\cos\left(\frac{\pi}{4} - \frac{\sqrt{x}}{2}\right) = \sin \sqrt{x}$$

$$\Rightarrow \cos\left(\frac{\pi}{4} - \frac{\sqrt{x}}{2}\right) = \cos\left(\frac{\pi}{2} - \sqrt{x}\right)$$

$$\Rightarrow \frac{\pi}{4} - \frac{\sqrt{x}}{2} = 2m\pi \pm \left(\frac{\pi}{2} - \sqrt{x}\right)$$

$$\Rightarrow \frac{\pi}{4} - \frac{\sqrt{x}}{2} = 2m\pi + \frac{\pi}{2} - \sqrt{x}$$

or  $\frac{\pi}{4} - \frac{\sqrt{x}}{2} = 2m\pi - \frac{\pi}{2} + \sqrt{x}$

$$\Rightarrow \frac{\sqrt{x}}{2} = 2m\pi + \frac{\pi}{4} \text{ or } \frac{-3\sqrt{x}}{2} = 2m\pi - \frac{3\sqrt{\pi}}{4}$$

$$\Rightarrow x = \left(4m\pi + \frac{\pi}{2}\right)^2 \text{ or } x = \left(\frac{4k\pi}{3} + \frac{\pi}{2}\right)^2; m, k \in \mathbb{Z}$$

11. Find the smallest positive root of the equation  $\sqrt{\sin(1-x)} = \sqrt{\cos x}$ .

**Solution:** The given equation is possible if  $\sin(1-x) \geq 0$  and  $\cos x \geq 0$

Squaring we get  $\sin(1-x) = \cos x = \sin(\pi/2 - x)$

$$\Rightarrow 1-x = n\pi + (-1)^n \left(\frac{\pi}{2} - x\right) \text{ where } n \in \mathbb{Z}$$

But for  $n = 2m$  ( $m \in \mathbb{Z}$ ) we get no value of  $x$ .

$\therefore$  For  $n = 2m + 1$ ; ( $m \in \mathbb{Z}$ )

$$1-x = (2m+1)\pi - \left(\frac{\pi}{2} - x\right)$$

$$\Rightarrow x = \frac{1}{2} - \frac{4m+1}{4}\pi \quad (m \in \mathbb{Z})$$

if  $m = 0$ ,  $x < 0$

For  $m = -1$ ,  $x = 1/2 + 3\pi/4 \Rightarrow 1-x = \frac{1}{2} - \frac{3\pi}{4}$

So that  $\sin(1-x)$

$$= \sin\left(\frac{1}{2} + \frac{\pi}{4} - \pi\right) = -\sin\left(\frac{\pi}{4} + \frac{1}{2}\right) < 0$$

For  $m = -2$ ,  $x = \frac{1}{2} + \frac{7\pi}{4} \Rightarrow 1-x = \frac{1}{2} - \frac{7\pi}{4}$

So that  $\sin(1-x) = \sin\left(\frac{1}{2} + \frac{\pi}{4} - 2\pi\right) > 0$

And  $\cos x = \cos\left(2\pi - \frac{\pi}{4} + \frac{1}{2}\right) > 0$

Hence  $x = \frac{1}{2} + \frac{7\pi}{4}$  is the smallest positive root of the given equation.

12. Solve  $\frac{\sin^3 \frac{x}{2} - \cos^3 \frac{x}{2}}{2 + \sin x} = \frac{\cos x}{3}$

**Solution:**  $3 \left( \sin^3 \frac{x}{2} - \cos^3 \frac{x}{2} \right) = \cos x (2 + \sin x)$

$$\Rightarrow 3 \left( \sin \frac{x}{2} - \cos \frac{x}{2} \right) \left( \sin^2 \frac{x}{2} + \sin \frac{x}{2} \cos \frac{x}{2} + \cos^2 \frac{x}{2} \right) = \cos x (2 + \sin x)$$

$$\Rightarrow 3 \left( \sin \frac{x}{2} - \cos \frac{x}{2} \right) \left( 1 + \sin \frac{x}{2} \cos \frac{x}{2} \right) = (\cos x)(2 + \sin x)$$

$$\Rightarrow 3 \left( \sin \frac{x}{2} - \cos \frac{x}{2} \right) \left( 1 + \frac{\sin x}{2} \right) = (\cos x)(2 + \sin x)$$

$$\Rightarrow \frac{3}{2} \left( \sin \frac{x}{2} - \cos \frac{x}{2} \right) (2 + \sin x) = (\cos x)(2 + \sin x)$$

$$\Rightarrow (2 + \sin x) \left[ \frac{3}{2} \left( \sin \frac{x}{2} - \cos \frac{x}{2} \right) - \cos x \right] = 0$$

$$\Rightarrow \frac{3}{2} \left( \sin \frac{x}{2} - \cos \frac{x}{2} \right) = \cos x \quad (\text{since } 2 + \sin x \neq 0)$$

$$\Rightarrow \frac{3}{2} \left( \sin \frac{x}{2} - \cos \frac{x}{2} \right) = \cos^2 \frac{x}{2} - \sin^2 \frac{x}{2}$$

$$\Rightarrow \left( \sin \frac{x}{2} - \cos \frac{x}{2} \right) \left( \sin \frac{x}{2} + \cos \frac{x}{2} + \frac{3}{2} \right) = 0$$

Since minimum value of  $\sin \frac{x}{2} + \cos \frac{x}{2}$  is  $-\sqrt{2}$  which

is greater than  $-\frac{3}{2} \Rightarrow \sin \frac{x}{2} + \cos \frac{x}{2} + \frac{3}{2} \neq 0$

$$\Rightarrow \sin \frac{x}{2} - \cos \frac{x}{2} = 0 \Rightarrow \tan \frac{x}{2} = 1 \Rightarrow \frac{x}{2} = n\pi + \frac{\pi}{4}$$

$$\Rightarrow x = (4n + 1) \frac{\pi}{2}, n \in \mathbb{Z}$$

13. Prove that the equation  $\cos(\sin x) = \sin(\cos x)$  does not possess real roots.

**Solution:**  $\cos(\sin x) = \sin(\cos x)$

$$\Rightarrow \cos(\sin x) = \cos(\pi/2 - \cos x)$$

$$\Rightarrow \sin x = 2n\pi \pm (\pi/2 - \cos x) \quad \dots \dots (1)$$

Taking +ve sign,

$$\sin x = 2n\pi + \pi/2 - \cos x$$

$$\text{or } (\cos x + \sin x) = (4n + 1)\pi/2$$

$$\text{or } \cos(x - \pi/4) = \frac{(4n + 1)\pi}{2\sqrt{2}}$$

$$\text{For } n \geq 0, \frac{(4n + 1)\pi}{2\sqrt{2}} > 1$$

$$\text{and for } n < 0, \frac{(4n + 1)\pi}{2\sqrt{2}} < -1$$

$$\text{so } \cos(x - \pi/4) \neq \frac{(4n + 1)\pi}{2\sqrt{2}} \text{ for any } n \in \mathbb{Z} \quad \dots (2)$$

Taking -ve sign

$$\sin x - \cos x = (4n - 1)\pi/2$$

$$\text{or } \sin(x - \pi/4) = \frac{(4n - 1)\pi}{2\sqrt{2}}$$

$$\text{for } n \geq 1, \frac{(4n - 1)\pi}{2\sqrt{2}} > 1$$

$$\text{and for } n \leq 0, \frac{(4n - 1)\pi}{2\sqrt{2}} < -1$$

$$\text{so } \sin(x - \pi/4) \neq \frac{(4n - 1)\pi}{2\sqrt{2}} \text{ for any } n \in \mathbb{Z} \quad \dots (3)$$

From (2) and (3), we conclude that the given equation does not possess any real solution.

14. Solve the equations  $4 \sin^4 x + \cos^4 x = 1$ .

**Solution:**  $4 \sin^4 x + \cos^4 x = 1$

$$\text{or } (2 \sin^2 x)^2 + \frac{1}{4} (2 \cos^2 x)^2 = 1$$

$$\text{or } (1 - \cos 2x)^2 + \frac{1}{4} (1 + \cos 2x)^2 = 1$$

$$\text{or } 5 \cos^2 2x - 6 \cos 2x + 1 = 0$$

$$\text{or } (\cos 2x - 1)(5 \cos 2x - 1) = 0$$

$$\therefore \cos 2x = 1 \text{ or } 5 \cos 2x = 1$$

$$\text{If } \cos 2x = 1, \text{ then } \cos 2x = 1 = \cos 0$$

$$\text{or } 2x = 2n\pi \text{ or } x = n\pi, \forall n \in \mathbb{Z}$$

$$\text{and if } 5 \cos 2x = 1,$$

$$\text{then } \cos 2x = 1/5 = \cos \alpha \text{ (say)}$$

$$\therefore 2x = 2n\pi \pm \alpha \text{ or } x = n\pi \pm \alpha/2, \forall n \in \mathbb{Z}$$

Hence the required solutions are

$$x = n\pi \text{ or } x = n\pi \pm \alpha/2, \forall n \in \mathbb{Z}$$

$$\text{where } \alpha = \cos^{-1}(1/5)$$

15. Find the values of  $x$ , between 0 and  $2\pi$ , satisfying the

$$\text{equation; } \cos 3x + \cos 2x = \sin \frac{3x}{2} + \sin \frac{x}{2}$$

**Solution:**  $\cos 3x + \cos 2x = \sin \frac{3x}{2} + \sin \frac{x}{2}$

$$2 \cos \frac{5x}{2} \cos \frac{x}{2} = 2 \sin x \cos \frac{x}{2}; 0 < x < 2\pi$$

2.50 > Trigonometry

$$\text{or } \cos \frac{x}{2} \left[ \cos \frac{5x}{2} - \sin x \right] = 0$$

$$\Rightarrow \cos \frac{x}{2} = 0 \text{ or } \cos \frac{5x}{2} = \sin x$$

$$\Rightarrow \frac{x}{2} = 2n\pi \pm \frac{\pi}{2}$$

$$\text{or } \frac{5x}{2} = 2n\pi \pm \left( \frac{\pi}{2} - x \right)$$

$$\text{for } n=0 \Rightarrow x = \pi, \frac{\pi}{7}$$

$$\text{for } n=1 \Rightarrow x = \frac{5\pi}{7}, \pi$$

$$\text{for } n=2 \Rightarrow x = \frac{9\pi}{7}$$

$$\text{for } n=3 \Rightarrow x = \frac{13\pi}{7}$$

$$\Rightarrow x = \frac{\pi}{7}, \frac{5\pi}{7}, \pi, \frac{9\pi}{7}, \frac{13\pi}{7}$$

16. Find the general values of  $\theta$  for which the quadratic function

$(\sin \theta)x^2 + (2 \cos \theta)x + \frac{\cos \theta + \sin \theta}{2}$  is the square of a linear function.

**Solution:** If  $(\sin \theta)x^2 + (2 \cos \theta)x + \frac{\cos \theta + \sin \theta}{2}$

is the square of a linear function therefore its discriminant will be zero.

$$\Rightarrow D = 0$$

$$\Rightarrow 4 \cos^2 \theta - 4(\sin \theta) \left( \frac{\cos \theta + \sin \theta}{2} \right) = 0$$

$$\Rightarrow 4 \cos^2 \theta - 2 \sin \theta \cos \theta - 2 \sin^2 \theta = 0$$

dividing by  $\cos^2 \theta$ , we get,

$$4 - 2 \tan \theta - 2 \tan^2 \theta = 0$$

$$\Rightarrow \tan^2 \theta + \tan \theta - 2 = 0$$

$$\Rightarrow \tan^2 \theta + 2 \tan \theta - \tan \theta - 2 = 0$$

$$\Rightarrow \tan \theta (\tan \theta + 2) - 1(\tan \theta + 2) = 0$$

$$\Rightarrow (\tan \theta + 2) (\tan \theta - 1) = 0$$

$$\Rightarrow \tan \theta = 1 \Rightarrow \theta = n\pi + \frac{\pi}{4}; n \in \mathbb{Z}$$

$$\text{or } \tan \theta = -2 \Rightarrow \theta = n\pi + \tan^{-1}(-2)$$

17. Find all the solutions of the equation  $1 + (\sin x - \cos x)$

$\sin \frac{\pi}{4} = 2 \cos^2 \left( \frac{5}{2}x \right)$  which satisfy the condition  $\sin 6x < 0$ .

**Solution:** Given equation is

$$1 + (\sin x - \cos x) \sin \frac{\pi}{4} = 2 \cos^2 \frac{5x}{2}$$

$$\Rightarrow 1 + (\sin x - \cos x) \frac{1}{\sqrt{2}} = 1 + \cos 5x$$

$$\Rightarrow \cos 5x + \cos(x + \pi/4) = 0$$

$$\Rightarrow 2 \cos(3x + \pi/8) \cos(2x - \pi/8) = 0$$

Thus initial equation is equivalent to equations,

$$\cos(3x + \pi/8) = 0 \text{ or } \cos(2x - \pi/8) = 0;$$

whose roots are, respectively  $x = \frac{\pi}{8} + \frac{\pi n}{3}; n \in \mathbb{Z} \dots(1)$

$$x = \frac{5\pi}{16} + \frac{\pi m}{2}; m \in \mathbb{Z} \dots(2)$$

$$\text{From (1), } 6x = 2n\pi + \frac{3\pi}{4}$$

$$\sin 6x < 0 \Rightarrow \pi < 6x < 2\pi \text{ (considering for } [0, 2\pi])$$

$$\Rightarrow \frac{1}{8} < n < \frac{5}{8}$$

No solution in this case.

$$\text{From (2), } 6x = 3m\pi + \frac{15\pi}{8}$$

$$\sin 6x < 0 \Rightarrow \pi < 6x < 2\pi \Rightarrow -\frac{7}{24} < m < \frac{1}{24}$$

$$\Rightarrow m = 0 \Rightarrow x = \frac{5\pi}{16}$$

$$\text{Hence general solution is } x = t\pi + \frac{5\pi}{16}, t \in \mathbb{Z}$$

18. Find the least positive angle measured in degrees satisfying the equation  $\sin^3 x + \sin^3 2x + \sin^3 3x = (\sin x + \sin 2x + \sin 3x)^3$ .

**Solution:**  $\sin^3 x + \sin^3 2x + \sin^3 3x = (\sin x + \sin 2x + \sin 3x)^3$

$$(\because (a + b + c)^3 = a^3 + b^3 + c^3 + 3a^2b + 3a^2c + 3ab^2 + 3ac^2 + 3b^2c + 3bc^2 + 6abc)$$

$$(c + a) = 0$$

$$\Rightarrow (\sin x + \sin 2x) (\sin 2x + \sin 3x) (\sin 3x + \sin x) = 0$$

$$\Rightarrow 2 \sin \frac{3x}{2} \cos \frac{x}{2} = 0 \text{ OR } 2 \sin \frac{5x}{2} \cos \frac{x}{2} = 0 \text{ 'OR'}$$

$$2 \sin 2x \cos x = 0$$

$$\Rightarrow \sin \frac{3x}{2} = 0 \Rightarrow x = \frac{2n\pi}{3}; n \in \mathbb{Z}$$

$$\text{or } \sin \frac{5x}{2} = 0 \Rightarrow x = \frac{2m\pi}{5}; m \in \mathbb{Z}$$

$$\text{or } \sin 2x = 0 \Rightarrow x = \frac{k\pi}{2}; k \in \mathbb{Z}$$

$$\text{or } \cos \frac{x}{2} = 0 \Rightarrow x = (2p + 1)\pi; p \in \mathbb{Z}$$

$$\text{or } \cos x = 0 \Rightarrow x = (2q + 1)\frac{\pi}{2}; q \in \mathbb{Z}$$

$\therefore$  least positive angle is  $\frac{2\pi}{5} = 72^\circ$  **Ans.**

19. Find the set of value of 'a' for which the equation,  $\sin^4 x + \cos^4 x + \sin 2x + a = 0$  possesses solutions. Also find the general solution for these values of 'a'.

**Solution:**  $\sin^4 x + \cos^4 x + \sin 2x + a = 0$   
 $\Rightarrow (\sin^2 x)^2 + (\cos^2 x)^2 + 2 \sin^2 x \cos^2 x - 2 \sin^2 x \cos^2 x + 2 \sin x \cos x + a = 0$   
 $\Rightarrow 1 - \frac{\sin^2 2x}{2} + \sin 2x + a = 0$   
 $\Rightarrow 2 - \sin^2 2x + 2 \sin 2x + 2a = 0$   
 $\Rightarrow 2a = \sin^2 2x - 2 \sin 2x - 2$   
 $\Rightarrow 2a + 3 = (\sin 2x - 1)^2$   
 $\Rightarrow 2a + 3 = (y - 1)^2$  where  $y \in [-1, 1]$   
 $\Rightarrow 2a + 3 \in [0, 4]$   
 $\Rightarrow a \in \left[ -\frac{3}{2}, \frac{1}{2} \right]$   
 $\sin 2x = 1 - \sqrt{2a + 3}$   
 $\sin 2x = \sin \alpha$  where  $\alpha = \sin^{-1} (1 - \sqrt{2a + 3})$   
 or  $x = \frac{1}{2} [n\pi + (-1)^n \sin^{-1} (1 - \sqrt{2a + 3})]$   
 where  $a \in \left[ -\frac{3}{2}, \frac{1}{2} \right]$

20. Solve the equation:  $1 + 2 \operatorname{cosec} x = -\frac{\sec^2 \frac{x}{2}}{2}$ .

**Solution:**  $1 + 2 \operatorname{cosec} x = -\frac{\sec^2 \frac{x}{2}}{2}$   
 $\Rightarrow 1 + 2 \left( \frac{1 + \tan^2 \frac{x}{2}}{2 \tan \frac{x}{2}} \right) = -\frac{(1 + \tan^2 \frac{x}{2})}{2}$   
 or  $2 \tan \frac{x}{2} + 2 + 2 \tan^2 \frac{x}{2} + \tan \frac{x}{2} + \tan^3 \frac{x}{2} = 0$   
 or  $\tan^3 \frac{x}{2} + 2 \tan^2 \frac{x}{2} + 3 \tan \frac{x}{2} + 2 = 0$   
 or  $\left( \tan \frac{x}{2} + 1 \right) \left( \tan^2 \frac{x}{2} + \tan \frac{x}{2} + 2 \right) = 0$  ... (1)  
 but  $\left( \tan^2 \frac{x}{2} + \tan \frac{x}{2} + 2 \right)$  has no real root ( $\because D < 0$ )  
 $\therefore \tan \left( \frac{x}{2} \right) + 1 = 0$

$$\text{or } \tan \frac{x}{2} = \tan \left( -\frac{\pi}{4} \right)$$

$$\text{or } x = 2n\pi - \frac{\pi}{2} \quad \text{Ans}$$

21. Find the general solution of the equation,

$$\sin \frac{2x+1}{x} + \sin \frac{2x+1}{3x} - 3 \cos^2 \frac{2x+1}{3x} = 0.$$

**Solution:**  $\sin \frac{2x+1}{x} + \sin \frac{2x+1}{3x} - 3 \cos^2 \frac{2x+1}{3x} = 0$

$$2 \sin \frac{4(2x+1)}{2 \times 3x} \cdot \cos \frac{2x+1}{3x} = 3 \cos^2 \frac{2x+1}{3x}$$

$$\text{or } 2 \sin \frac{2(2x+1)}{3x} \cos \frac{2x+1}{3x} = 3 \cos^2 \frac{2x+1}{3x}$$

$$\text{or } 4 \sin \frac{(2x+1)}{3x} \cos^2 \left( \frac{2x+1}{3x} \right) - 3 \cos^2 \frac{2x+1}{3x} = 0$$

$$\Rightarrow \cos^2 \left( \frac{2x+1}{3x} \right) = 0$$

$$\text{or } \sin \frac{2x+1}{3x}$$

$$= \frac{3}{4} = \sin \alpha, \text{ where } \alpha = n\pi + (-1)^n \cdot \sin^{-1} \left( \frac{3}{4} \right)$$

$$\cos^2 \left( \frac{2x+1}{3x} \right) = \cos^2 \frac{\pi}{2}$$

$$\Rightarrow \frac{2x+1}{3x} = n\pi \pm \frac{\pi}{2}$$

$$\Rightarrow x = \frac{2}{3(2n \pm 1)\pi - 4}$$

$$\text{or } \sin \left( \frac{2x+1}{3x} \right) = \sin \alpha$$

$$\Rightarrow x = \frac{1}{3\alpha - 2} \text{ where } \alpha = n\pi + (-1)^n \sin^{-1} \left( \frac{3}{4} \right)$$

22. Find all the solutions of the equation

$$\sin \left( x - \frac{\pi}{4} \right) - \cos \left( x + \frac{3\pi}{4} \right) = 1$$

which satisfy the inequality  $\frac{2 \cos 7x}{\cos 3 + \sin 3} > 2^{\cos 2x}$ .

$$x = 2n\pi + 3\pi/3, n \in \mathbb{Z}.$$

**Solution:** Given,  $\sin \left( x - \frac{\pi}{4} \right) - \cos \left( x + \frac{3\pi}{4} \right) = 1$



2.52 > Trigonometry

$$\Rightarrow \sqrt{2} \left[ \frac{1}{\sqrt{2}} \sin \left( x - \frac{\pi}{4} \right) + \frac{1}{\sqrt{2}} \cos \left( x - \frac{\pi}{4} \right) \right] = 1$$

$$\Rightarrow \sqrt{2} \left[ \sin \left( x - \frac{\pi}{4} \right) \cos \frac{\pi}{4} + \cos \left( x - \frac{\pi}{4} \right) \sin \frac{\pi}{4} \right] = 1$$

$$\Rightarrow \sqrt{2} [\sin(x - \pi/4 + \pi/4)] = 1$$

$$\Rightarrow \sqrt{2} \sin x = 1 \Rightarrow \sin x = \frac{1}{\sqrt{2}}$$

$\frac{2 \cos 7x}{\cos 3 + \sin 3} > 2^{\cos 2x}$  we must find the interval that

satisfies both the above conditions which can be calculated by finding their periods.

As period for  $\sin \left( x - \frac{\pi}{4} \right) - \cos \left( x + \frac{3\pi}{4} \right) = 1$  is  
L.C.M of  $\{2\pi, 2\pi\} = 2\pi$  ... (ii)

Also the period for the inequality is LCM of  $\left\{ \frac{2\pi}{7}, \pi \right\}$   
 $\Rightarrow 2\pi$  ... (iii)

From (i) and (iii) we must check at  $x = \pi/4$  and  $3\pi/4$   
(as they lie  $[0, 2\pi]$ )

(i) at  $x = \frac{\pi}{4}$

$$\begin{aligned} \text{L.H.S. } \frac{2 \cos 7x}{\cos 3 + \sin 3} &= \frac{2 \cos \frac{7\pi}{4}}{\cos 3 + \sin 3} = \frac{2 \cos \frac{\pi}{4}}{\cos 3 + \sin 3} \\ &= \frac{1}{\sin \left( 3 + \frac{\pi}{4} \right)} < 0 \end{aligned}$$

where as  $2^{\cos 2x} = 2^{\cos \pi/2} = 2^0 = 1$

which shows  $x = 2n\pi + \pi/4$  is not a solution of the inequality

(ii) Again at  $x = \frac{3\pi}{4}$ ,

$$\begin{aligned} \frac{2 \cos 7x}{\cos 3 + \sin 3} &= \frac{2 \cos \frac{21\pi}{4}}{\cos 3 + \sin 3} \\ &= \frac{-2 \cos \frac{\pi}{4}}{\cos 3 + \sin 3} = \frac{-1}{\sin \left( 3 + \frac{\pi}{4} \right)} > 1 \end{aligned}$$

Where as  $2^{\cos 2x} = 2^{\cos \frac{6\pi}{4}} = 1$

which shows  $\frac{2 \cos 7x}{\cos 3 + \sin 3} > 2^{\cos 2x}$

Hence,  $x = 2n\pi + \frac{3\pi}{4}$  is the solution

23. Solve the trigonometric equation

$$|\cos x - 2 \sin 2x - \cos 3x| = 1 - 2 \sin x - \cos 2x.$$

**Solution:** From the given equation, we have

$$|\cos x - 2 \sin 2x - \cos 3x| = (1 - \cos 2x) - 2 \sin x$$

$$\Rightarrow |(\cos x - \cos 3x) - 2 \sin 2x| = 2 \sin^2 x - 2 \sin x$$

$$\Rightarrow |2 \sin 2x(\sin x - 1)| = 2 \sin x(\sin x - 1)$$

$$\Rightarrow 2|\sin x| |\cos x| (1 - \sin x) = \sin x(\sin x - 1);$$

since  $\sin x - 1 \leq 0$

$$\Rightarrow (\sin x - 1) [\sin x + 2 |\sin x| |\cos x|] = 0$$

$$\Rightarrow \text{Either } \sin x - 1 = 0 \quad \dots (1)$$

$$\text{or } \sin x + 2|\sin x| |\cos x| = 0 \quad \dots (2)$$

Equation (1)

$$\Rightarrow \sin x = 1 \Rightarrow x = (4n+1)\frac{\pi}{2}; n \in \mathbb{Z}$$

In order to solve (2), we discuss two possibilities according as

**Case 1:** Let  $\sin x \geq 0$ ; then the equation (2) reduces to  $\sin x + 2 \sin x |\cos x| = 0$

$$\Rightarrow \sin x(1 + 2|\cos x|) = 0$$

Since  $1 + 2|\cos x| = 0$  will give impossible solution as

$$|\cos x| = -\frac{1}{2}$$

$$\therefore \text{ We must have } \sin x = 0 \Rightarrow x = n\pi, n \in \mathbb{Z}$$

**Case 2:** Let  $\sin x < 0$

Then equation (2) reduces to

$$\sin x - 2 \sin x |\cos x| = 0 \Rightarrow \sin x(1 - 2|\cos x|) = 0$$

Hence  $\sin x = 0$  is not possible, since we have taken  $\sin x < 0$ ; Hence we have  $1 - 2|\cos x| = 0$

$$\Rightarrow |\cos x| = 1/2$$

$$\Rightarrow \cos x = \pm 1/2$$

$$\Rightarrow x = (2n+1)\pi + \frac{\pi}{3} \text{ or } 2n\pi - \frac{\pi}{3}; n \in \mathbb{Z}$$

24. Solve the equation

$$\cos(\pi 3^x) - 2 \cos^2(\pi 3^x) + 2 \cos(4\pi 3^x) - \cos(7\pi 3^x)$$

$$= \sin(\pi 3^x) + 2 \sin^2(\pi 3^x) - 2 \sin(4\pi 3^x) +$$

$$2 \sin(\pi 3^{x+1}) - \sin(7\pi 3^x).$$

**Solution:** Let  $\pi 3^x = \theta$ , then

$$\Rightarrow \cos \theta - 2 \cos^2 \theta + 2 \cos 4\theta - \cos 7\theta = \sin \theta + 2 \sin^2 \theta - 2 \sin 4\theta + 2 \sin 3\theta - \sin 7\theta$$

$$\Rightarrow \cos \theta - \cos 7\theta + \sin 7\theta - \sin \theta + 2(\cos 4\theta + \sin 4\theta) = 2 + 2 \sin 3\theta$$

$$\Rightarrow 2 \sin 4\theta \cdot \sin 3\theta + 2 \cos 4\theta \cdot \sin 3\theta + 2(\cos 4\theta + \sin 4\theta) = 2 + 2 \sin 3\theta$$

$$\Rightarrow \sin 4\theta (\sin 3\theta + 1) + \cos 4\theta (\sin 3\theta + 1) - (1 + \sin 3\theta) = 0$$

$$\Rightarrow (\sin 3\theta + 1) (\sin 4\theta + \cos 4\theta - 1) = 0$$

$$\begin{aligned} \Rightarrow \sin 3\theta &= -1 \Rightarrow 3\theta = 2n\pi - \frac{\pi}{2} \\ \Rightarrow 3\pi 3^x &= 2n\pi - \frac{\pi}{2} \\ \Rightarrow 3^{x+1} &= 2n - \frac{1}{2} \Rightarrow x+1 = \log_3 \frac{4n-1}{2} \end{aligned}$$

$$\Rightarrow x = \log_3 \frac{4n-1}{2} - 1$$

$$\text{And } \sin 4\theta + \cos 4\theta = 1$$

$$\Rightarrow \sin\left(4\theta + \frac{\pi}{4}\right) = \sin \frac{\pi}{4} \Rightarrow 4\theta + \frac{\pi}{4} = n\pi + (-1)^n \frac{\pi}{4}$$

$$\Rightarrow 4\pi 3^x = n\pi + (-1)^n \frac{\pi}{4} - \frac{\pi}{4}$$

$$\Rightarrow 3^x = \frac{n}{4} + (-1)^n \frac{\pi}{16} - \frac{\pi}{16}$$

$$\Rightarrow x = \log_3 \left( \frac{n}{4} + (-1)^n \frac{\pi}{16} - \frac{\pi}{16} \right)$$

25. Find the value of 'a' so that the equation

$$\cos^2 \left[ \frac{\pi}{10} (2\cos^2 x - 5\cos x + 2) \right] = \sec^2(x + a \sec^2 x)$$

has a real solution.

**Solution:** Since  $\cos^2 \theta \leq 1$  and  $\sec^2 \alpha \geq 1$

$$\Rightarrow \cos^2 \left[ \frac{\pi}{10} (2\cos^2 x - 5\cos x + 2) \right] = 1$$

$$\Rightarrow \frac{\pi}{10} (2\cos^2 x - 5\cos x + 2) = n\pi \quad \forall n \in \mathbb{Z}$$

$$\Rightarrow 2\cos^2 x - 5\cos x + 2 = 10n, n \in \mathbb{Z}$$

$$\text{Now, } 2\cos^2 x - 5\cos x + 2 = 2 \left[ \cos x - \frac{5}{4} \right]^2 - \frac{9}{8}$$

$$\Rightarrow -1 \leq 2\cos^2 x - 5\cos x + 2 \leq 9$$

$\Rightarrow$  In equation (1) only one value of  $n$  is possible i.e.,  $n = 0$

$$\Rightarrow 2\cos^2 x - 5\cos x + 2 = 0$$

$$\Rightarrow (2\cos x - 1)(\cos x - 2) = 0$$

$$\Rightarrow x = 2n\pi \pm \frac{\pi}{3}$$

$$\Rightarrow \sec^2 \left( 2n\pi \pm \frac{\pi}{3} + a \sec^2 \left( 2n\pi \pm \frac{\pi}{3} \right) \right) = 1$$

$$\Rightarrow \sec^2 \left( 2n\pi \pm \frac{\pi}{3} + 2a \right) = 1$$

$$\Rightarrow 2a = r\pi \pm \frac{\pi}{3}$$

$$\Rightarrow a = \frac{r\pi}{2} \pm \frac{\pi}{6} \quad \text{where } r \in \mathbb{Z}$$

26. Solve the equation:

$$\cos^2 \left[ \frac{\pi}{4} (\sin x + \sqrt{2} \cos^2 x) \right] - \tan^2 \left( x + \frac{\pi}{4} \tan^2 x \right) = 1$$

**Solution:**

$$\cos^2 \left[ \frac{\pi}{4} (\sin x + \sqrt{2} \cos^2 x) \right] - \tan^2 \left( x + \frac{\pi}{4} \tan^2 x \right) = 1$$

$\therefore$  the square of the cosine of any argument does not exceed 1, the given equation holds true if and only if we have, simultaneously

$$\cos^2 \left[ \frac{\pi}{4} (\sin x + \sqrt{2} \cos^2 x) \right] = 1$$

$$\text{and } \tan^2 \left( x + \frac{\pi}{4} \tan^2 x \right) = 0 \quad \dots(1)$$

we thus have a system of 2 equations in one unknown. To solve it we find the roots of the first equation and then substitute them into the second equation and then choose those that satisfy the second equation and hence the system. From the first equation, we get;

$$\frac{\pi}{4} (\sin x + \sqrt{2} \cos^2 x) = k\pi$$

$$\Rightarrow \sin x + \sqrt{2} \cos^2 x = 4k, k \in \mathbb{Z}$$

But we also know that

$$|\sin x + \sqrt{2} \cos^2 x| \leq |\sin x| + \sqrt{2} |\cos^2 x| \leq 1 + \sqrt{2} < 4$$

$\therefore$  The equation has no solution for  $k \neq 0$ . We consider  $k = 0$

$$\sin x + \sqrt{2} \cos^2 x = 0 \text{ i.e., } (\sin x - \sqrt{2})(\sqrt{2} \sin x + 1) = 0$$

$$\Rightarrow \sin x = -1/\sqrt{2} \Rightarrow x = n\pi + (-1)^{n+1} \frac{\pi}{4}$$

$$\text{If } n \text{ is odd, } x = (2k+1)\pi + \frac{\pi}{4}$$

Putting this in equation (1), we get,

$$\tan \left[ (2k+1)\pi + \frac{\pi}{4} + \frac{\pi}{4} \right]$$

$$= \tan \frac{\pi}{2} \text{ which is undefined.}$$

$$\text{If } n \text{ is even, } x = 2k\pi - \frac{\pi}{4}$$

Putting this in equation (1), we get,

$$\tan \left[ 2k\pi - \frac{\pi}{4} + \frac{\pi}{4} \right] = 0$$

$$\text{Hence } x = 2k\pi - \frac{\pi}{4}; k \in \mathbb{Z}$$

27. Solve the following system of equations for  $x$  and  $y$

$$5^{(\cos^2 x - 3\sec^2 y)} = 1 \text{ and } 2^{(2\cos^2 x + \sqrt{3}|\sec y|)} = 64.$$

**Solution:**  $5^{(\cos^2 x - 3\sec^2 y)} = 1 = 5^0$  and

$$2^{(2\cos^2 x + \sqrt{3}|\sec y|)} = 64 = 2^6$$

$$\Rightarrow \cos^2 x - 3\sec^2 y = 0 \quad \dots(i)$$

$$\text{and } 2 \cos^2 x + \sqrt{3} |\sec y| = 6 \quad \dots(ii)$$

$$\text{putting the value of } \sqrt{3} |\sec y|$$

2.54 > Trigonometry

from equation (ii) in (i), we get,

$$\operatorname{cosec}^2 x - (6 - 2 \operatorname{cosec} x)^2 = 0$$

$$\Rightarrow \operatorname{cosec}^2 x - 36 + 24 \operatorname{cosec} x - 4 \operatorname{cosec}^2 x = 0$$

$$\Rightarrow 3 \operatorname{cosec}^2 x - 24 \operatorname{cosec} x + 36 = 0$$

$$\Rightarrow \operatorname{cosec}^2 x - 8 \operatorname{cosec} x + 12 = 0$$

$$\Rightarrow \operatorname{cosec}^2 x - 6 \operatorname{cosec} x - 2 \operatorname{cosec} x + 12 = 0$$

$$\Rightarrow \operatorname{cosec} x = 2, 6$$

putting the value of  $\operatorname{cosec} x$  in equation (ii); we get,

**Either,**  $4 + \sqrt{3} |\sec y| = 6$  or  $|2 + \sqrt{3} |\sec y|| = 6$

$$\Rightarrow \sqrt{3} |\sec y| = 2 \quad \text{or} \quad \sqrt{3} |\sec y| = -6$$

$$\Rightarrow |\sec y| = \frac{2}{\sqrt{3}} \quad \text{or} \quad |\sec y| = -2\sqrt{3}$$

$$\Rightarrow \cos^2 y = \frac{3}{4} = \cos^2 \frac{\pi}{6} \quad \therefore y = m\pi \pm \frac{\pi}{6}$$

$$\operatorname{cosec} x = 2 \Rightarrow \sin x = \frac{1}{2} \Rightarrow x = n\pi + (-1)^n \pi/6$$

$$x = n\pi + (-1)^n \pi/6; y = m\pi \pm \frac{\pi}{6}; m, n \in \mathbb{Z}$$

28. Let  $f(x) = \sin^6 x + \cos^6 x + k(\sin^4 x + \cos^4 x)$  for some real number  $k$ . Determine

(a) all real numbers  $k$  for which  $f(x)$  is constant for all values of  $x$ .

(b) all real numbers  $k$  for which there exists a real number 'c' such that  $f(c) = 0$ .

(c) If  $k = -0.7$ , determine all solutions to the equation  $f(x) = 0$ .

**Solution:**  $f(x) = \sin^6 x + \cos^6 x + k(\sin^4 x + \cos^4 x)$

(a)  $f(x) = \sin^6 x + \cos^6 x + k(\sin^4 x + \cos^4 x) = \text{constant}$

$$\Rightarrow (\sin^2 x)^3 + (\cos^2 x)^3 + k[(\sin^2 x)^2 + (\cos^2 x)^2] = \text{constant}$$

$$\Rightarrow (\sin^2 x + \cos^2 x)^3 - 3\sin^2 x \cdot \cos^2 x (\sin^2 x + \cos^2 x)$$

$$+ k[(\sin^2 x + \cos^2 x)^2 - 2\sin^2 x \cdot \cos^2 x] = \text{constant}$$

$$\Rightarrow (1 - 3\sin^2 x \cos^2 x) + k[1 - 2\sin^2 x \cos^2 x] = \text{constant}$$

Now,  $(1 - 3\sin^2 x \cos^2 x) + k[1 - 2\sin^2 x \cos^2 x]$  will be constant only when  $k = -3/2$  such that  $\sin^2 x \cos^2 x$  will get removed

$$\therefore \text{at } \left(k = -\frac{3}{2}\right), f(x) = 1 - 3/2 = -1/2$$

(b)  $\sin^6 x + \cos^6 x + k(\sin^4 x + \cos^4 x) = 0$

$$\text{or } 1 - 3\sin^2 x \cos^2 x + k(1 - 2\sin^2 x \cos^2 x) = 0$$

$$\text{or } 1 - 2\sin^2 x \cos^2 x + k(1 - 2\sin^2 x \cos^2 x) = \sin^2 x \cos^2 x$$

$$\text{or } (1 - 2\sin^2 x \cos^2 x)(k + 1) = \sin^2 x \cos^2 x$$

$$\text{or } k + 1 = \frac{\sin^2 x \cos^2 x}{1 - 2\sin^2 x \cos^2 x}$$

$$\text{or } k = \frac{3\sin^2 x \cos^2 x - 1}{1 - 2\sin^2 x \cos^2 x}$$

$$\text{minimum of } \sin^2 \theta \cos^2 \theta = 0 \text{ at } \theta = 0, \pi/2$$

maximum of  $\sin^2 \theta \cos^2 \theta = 1/4$  at  $\theta = 45^\circ = \pi/4$

Let  $\sin^2 x \cdot \cos^2 x = t$

$$\therefore k = \left[\frac{3t-1}{1-2t}\right]; \text{ where } t \in \left[0, \frac{1}{4}\right]$$

$$\Rightarrow k \in \left[-1, -\frac{1}{2}\right]$$

(c)  $(1 - 3\sin^2 \theta \cos^2 \theta) - 0.7(1 - 2\sin^2 \theta \cos^2 \theta) = 0$

$$\Rightarrow -\frac{7}{10} = \frac{1 - 3\sin^2 \theta \cos^2 \theta}{2\sin^2 \theta \cos^2 \theta - 1}$$

$$\text{or } (4\sin \theta \cos \theta)^2 = 3$$

$$\text{or } 2\sin 2\theta \pm \sqrt{3}$$

$$\text{or } \sin 2\theta = \pm \frac{\sqrt{3}}{2} = \sin\left(\pm \frac{\pi}{3}\right)$$

$$\text{or } 2\theta = n\pi + (-1)^n (\pm \pi/3) \text{ or } \theta = \frac{n\pi}{2} \pm (-1)^n \frac{\pi}{6}; n \in \mathbb{Z}$$

29. Show that the equation  $\sin(x + \alpha) = a \sin 2x + b$  has four roots whose sum is equal to  $(2n + 1)\pi$  where  $n \in \mathbb{Z}$ .

**Solution:**  $\sin x \cos \alpha + \cos x \sin \alpha = 2a \sin x \cos x + b$

$$\Rightarrow \sin x \cos \alpha + \cos x \sin \alpha - 2a \sin x \cos x - b = 0$$

$$\text{put } \sin x = \frac{2 \tan \frac{x}{2}}{1 + \tan^2 \frac{x}{2}} \text{ and } \cos x = \frac{1 - \tan^2 \frac{x}{2}}{1 + \tan^2 \frac{x}{2}}$$

let  $\tan x/2 = t$ , then

$$\Rightarrow \frac{2t}{1+t^2} \cos \alpha + \frac{1-t^2}{1+t^2} \sin \alpha - 2a \frac{2t(1-t^2)}{(1+t^2)^2} - b = 0$$

$$\Rightarrow (2t + 2t^3) \cos \alpha + (1 - t^4) \sin \alpha - 4at(1 - t^2) - b(1 + t^4 + 2t^2) = 0$$

$$\Rightarrow (-\sin \alpha - b)t^4 + (2\cos \alpha + 4a)t^3 + (-2b)t^2 + (2\cos \alpha - 4a)t + (\sin \alpha - b) = 0$$

$$\Rightarrow t_1 + t_2 + t_3 + t_4 = \frac{2\cos \alpha + 4a}{\sin \alpha + b}, \Sigma t_1 t_2 = \frac{2b}{\sin \alpha + b},$$

$$\Sigma t_1 t_2 t_3 = \frac{2\cos \alpha - 4a}{\sin \alpha + b}, t_1 t_2 t_3 t_4 = \frac{-\sin \alpha + b}{\sin \alpha + b}$$

$$\Rightarrow \tan\left(\frac{x_1 + x_2 + x_3 + x_4}{2}\right) = \frac{\frac{2\cos \alpha + 4a}{\sin \alpha + b} - \frac{2\cos \alpha - 4a}{\sin \alpha + b}}{1 - \frac{2b}{\sin \alpha + b} + \frac{b - \sin \alpha}{b + \sin \alpha}}$$

$$= \frac{8a}{\frac{\sin \alpha + b}{\sin \alpha + b - 2b + b - \sin \alpha}} = \frac{8a}{\sin \alpha + b}$$

$$\Rightarrow \frac{x_1 + x_2 + x_3 + x_4}{2} = n\pi + \frac{\pi}{2}$$

$$\Rightarrow x_1 + x_2 + x_3 + x_4 = 2n\pi + \pi = (2n + 1)\pi \quad \forall n \in \mathbb{Z}$$

## SECTION-II

### OBJECTIVE SOLVED EXAMPLES

1. Solution of equation  $\sin^2 x \cos x + 4 \sin x \cos x - \cos^2 x \sin x - 4 \sin x + 4 \cos x - 2 = 0$ , for real valued  $x$ , is

- (a)  $n\pi + \tan^{-1} 1/2$  ( $n \in \mathbb{Z}$ )
- (b)  $n\pi + \frac{\pi}{4}$  ( $n \in \mathbb{Z}$ )
- (c)  $n\pi - \tan^{-1} 1/2$  ( $n \in \mathbb{Z}$ )
- (d)  $n\pi \pm \frac{\pi}{4}$  ( $n \in \mathbb{Z}$ )

**Solution:**  $\sin x \cos x (\sin x - \cos x) + 2(1 - (\sin x - \cos x)^2) - 4(\sin x - \cos x) - 2 = 0$   
 $\Rightarrow (\sin x - \cos x) (\sin x \cos x - 2 (\sin x - \cos x) - 4) = 0$   
 $\Rightarrow (\sin x - \cos x) (\sin x + 2) (\cos x - 2) = 0$   
 $\Rightarrow \tan x = 1$   
 $\Rightarrow x = n\pi + \frac{\pi}{4}; n \in \mathbb{Z}$

2. The number of solutions of the equation  $2^{\cos x} = |\sin x|$  in  $[-2\pi, 2\pi]$  is

- (a) 1
- (b) 2
- (c) 8
- (d) 4

**Solution:** (c) We have  $2^{\cos x} = |\sin x|$   
 The equation holds true for  $x = \pi/2$  and also for some value  $\in (\pi/2, \pi)$

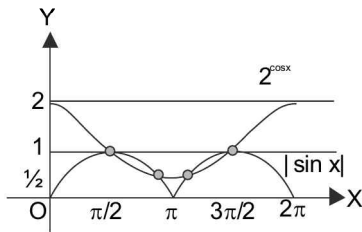

$\therefore$  at  $x = \pi/2$ , Slope of LHS and RHS do not match so curves do not touch rather they intersect. Thus there will be  $2 \times 4 = 8$  number of solutions in  $[-2\pi, 2\pi]$

3. If  $x^2 - 4x + 5 - \sin y = 0, y \in [0, 2\pi]$ , then

- (a)  $x = 1, y = 0$
- (b)  $x = 1, y = \pi/2$
- (c)  $x = 2, y = 0$
- (d)  $x = 2, y = \pi/2$

**Solution:** (d)  $(x - 2)^2 + 1 = \sin y$   
 The minimum value of LHS is 1 while maximum value of RHS is 1.

So solution exist iff the minima of the LHS coincide the maxima of the RHS. i.e.,

$$\Rightarrow x = 2, \sin y = 1 \quad \Rightarrow x = 2, y = \pi/2$$

4. The number of points on or within the circle  $x^2 + y^2 \leq 4$  satisfying  $\tan^4 x + \cot^4 x + 1 = 3 \sin^2 2y$  is

- (a) one
- (b) two
- (c) four
- (d) infinite

**Solution:** (c)  $\tan^4 x + \cot^4 x + 1 = (\tan^2 x - \cot^2 x)^2 + 3 \geq 3$  and  $3 \sin^2 2y \leq 3$

$\Rightarrow \tan^2 x = \cot^2 x$  and  $\sin^2 2y = 1$   
 $\Rightarrow \tan^2 x = 1, \sin^2 2y = 1$   
 $\Rightarrow x$  and  $y$  both belongs to set  $n\pi \pm \pi/4$   
 i.e.,  $\{\pm \pi/4, \pm 3\pi/4, \dots\}$   
 $\Rightarrow x^2 + y^2 = 4 \Rightarrow x^2 \leq 4$  and  $y^2 \leq 4$   
 $\Rightarrow x = \pm \frac{\pi}{4}$  and  $y = \pm \frac{\pi}{4}$   
 $\Rightarrow$  So only four solutions are possible.

5. The number of all possible 5 - tuples  $(a_1, a_2, a_3, a_4, a_5)$  such that  $a_1 + a_2 \sin x + a_3 \cos x + a_4 \sin 2x + a_5 \cos 2x = 0$  holds for all  $x$  is

- (a) zero
- (b) 1
- (c) 2
- (d) infinite

**Solution:** (b) Since the equation  $a_1 + a_2 \sin x + a_3 \cos x + a_4 \sin 2x + a_5 \cos 2x = 0$  ... (i) holds for all values of  $x$ .

So putting  $x = 0$  in equation (i),  $a_1 + a_3 + a_5 = 0$   
 On putting  $x = \pi$ ,  $a_1 - a_3 + a_5 = 0$  in equation ..... (i)  
 $\Rightarrow a_3 = 0$  and  $a_1 + a_5 = 0$  ..... (ii)  
 Putting  $x = \pi/2$  and  $3\pi/2$ , we get  
 $a_1 + a_2 - a_5 = 0$  and  $a_1 - a_2 - a_5 = 0$   
 $\Rightarrow a_2 = 0$  and  $a_1 - a_5 = 0$  ..... (iii)

From (i) and (ii) we get  $a_1 = a_2 = a_3 = a_5 = 0$   
 The given equation reduces to  $a_4 \sin 2x = 0$ . This is true for all values of  $x$ , therefore  $a_4 = 0$ . Hence  $a_1 = a_2 = a_3 = a_4 = a_5 = 0$ . Thus the number of 5-tuples satisfying the equation is one.

6. If  $\cot x \cot y = k$  and  $x + y = \pi/3$ , then  $\tan x$ ,  $\tan y$  satisfy the equation

- (a)  $kt^2 - \sqrt{3}(k-1)t + 1 = 0$
- (b)  $kt^2 + \sqrt{3}(k-1)t + 1 = 0$
- (c)  $kt^2 - \sqrt{3}(k+1)t + 1 = 0$
- (d)  $kt^2 + \sqrt{3}(k+1)t + 1 = 0$

**Solution:** (a)  $\tan(x+y) = \sqrt{3} \Rightarrow \frac{\tan x + \tan y}{1 - \tan x \tan y} = \sqrt{3}$   
 $\Rightarrow$  taking  $\tan x + \tan y = (1 - \tan x \tan y) \sqrt{3}$   
 $\Rightarrow \tan x + \tan y = \sqrt{3} \left( \frac{k-1}{k} \right)$  and product of root  
 $\tan x \tan y = 1/k$   
Hence  $\tan x$  and  $\tan y$  are the roots of  $k t^2 - \sqrt{3}(k-1)t + 1 = 0$   
i.e.,  $t^2 - \left( \sqrt{3} \left( \frac{k-1}{k} \right) \right) t + \frac{1}{k} = 0$

7. The set of all  $x \in (-\pi, \pi)$  satisfying  $|4 \sin x - 1| < \sqrt{5}$  is given by

- (a)  $\left(-\frac{\pi}{10}, \frac{3\pi}{10}\right)$       (b)  $\left(\frac{\pi}{10}, \frac{3\pi}{10}\right)$   
(c)  $\left(\frac{\pi}{10}, -\frac{3\pi}{10}\right)$       (d) None of these

**Solution:** (a) We are given the equation  $|4 \sin x - 1| < \sqrt{5}$

$$\begin{aligned} \Rightarrow -\sqrt{5} < 4 \sin x - 1 < \sqrt{5} \\ \Rightarrow -\left(\frac{\sqrt{5}-1}{4}\right) < \sin x < \left(\frac{\sqrt{5}+1}{4}\right) \\ \Rightarrow -\sin \frac{\pi}{10} < \sin x < \cos \frac{\pi}{5} \\ \Rightarrow \sin\left(-\frac{\pi}{10}\right) < \sin x < \sin\left(\frac{\pi}{2} - \frac{\pi}{5}\right) \\ \Rightarrow \sin\left(-\frac{\pi}{10}\right) < \sin x < \sin \frac{3\pi}{10}; x \in \left(-\frac{\pi}{10}, \frac{3\pi}{10}\right) \end{aligned}$$

8: The values of  $x$  between 0 and  $2\pi$  which satisfy the equation  $\sin x \sqrt{8 \cos^2 x} = 1$  are in A.P. whose common difference is

- (a)  $\pi/4$       (b)  $\pi/8$   
(c)  $3\pi/8$       (d)  $5\pi/8$

**Solution:** (a) Given equation is  $\sin x \sqrt{8 \cos^2 x} = 1$   
 $\Rightarrow \sin x |\cos x| = \frac{1}{2\sqrt{2}}$

**Case I:** When  $\cos x > 0$

$$\begin{aligned} \text{In this case equation becomes } \sin x \cos x &= \frac{1}{2\sqrt{2}} \\ \Rightarrow \sin 2x &= \frac{1}{\sqrt{2}} \Rightarrow 2x = \frac{\pi}{4}, \frac{3\pi}{4}, \frac{9\pi}{4}, \frac{11\pi}{4} \\ \Rightarrow x &= \frac{\pi}{8}, \frac{3\pi}{8}, \frac{9\pi}{8}, \frac{11\pi}{8} \end{aligned}$$

As  $x$  lies between 0 and  $2\pi$  and  $\cos x > 0$ ,  $x = \frac{\pi}{8}, \frac{3\pi}{8}$

**Case II:** When  $\cos x < 0$

$$\begin{aligned} \text{In this case equation becomes } \sin x (-\cos x) &= \frac{1}{2\sqrt{2}} \\ \Rightarrow \sin x \cos x &= -\frac{1}{2\sqrt{2}} \text{ or } \sin 2x = -\frac{1}{\sqrt{2}} \end{aligned}$$

$$\Rightarrow x = \frac{5\pi}{8}, \frac{7\pi}{8}, \frac{13\pi}{8}, \frac{15\pi}{8}$$

$$\Rightarrow x = \frac{5\pi}{8}, \frac{7\pi}{8} \text{ as } \cos x < 0 \text{ and } x \in (0, 2\pi)$$

Thus the values of  $x$  satisfying the given equation

which lie between 0 and  $2\pi$  are  $\frac{\pi}{8}, \frac{3\pi}{8}, \frac{5\pi}{8}, \frac{7\pi}{8}$ .

These are in A.P. with common difference  $\pi/4$

9. The ratio of the number of the roots of the equation  $x + 2 \tan x = \pi/2$ , to the number of roots of the equation  $2 \tan x - x = \pi/2$  in the interval  $[0, 2\pi]$  is

- (a) 1/2      (b) 3/2  
(c) 2/3      (d) infinite

**Solution:** (b) We have  $x + 2 \tan x = \pi/2$  and  $2 \tan x - x = \pi/2$

$$\Rightarrow \tan x = \pi/4 - x/2 \text{ and } \tan x = \pi/4 + x/2$$

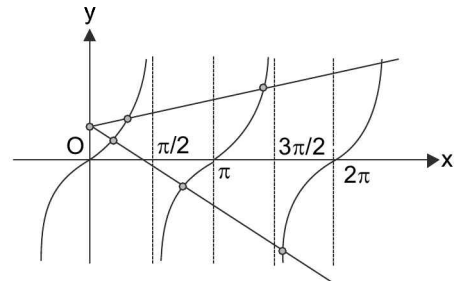

Now the graphs of the curve  $y = \tan x$  and  $y = \pi/4 - x/2$  in the interval  $[0, 2\pi]$  intersect at three points while  $y = \tan x$  and  $y = \pi/4 + x/2$  intersect at two points. The abscissa of these points are the roots of the corresponding equation. So the required ratio is 3/2.

10. If  $0 \leq x \leq \pi$  and  $81^{\sin^2 x} + 81^{\cos^2 x} = 30$ , then  $x$  is equal to

- (a)  $\pi/6$       (b)  $\pi/3$   
(c)  $5\pi/6$       (d)  $2\pi/3$

**Solution:** (a, b, c, d) Let  $81^{\sin^2 x} = y$

$$\text{Then } 81^{\cos^2 x} = 81^{1-\sin^2 x} = 81y^{-1}$$

So that the given equation can be written  $y^2 - 30y + 81 = 0$

$$\Rightarrow y = 3 \text{ or } y = 27$$

$$\Rightarrow 81^{\sin^2 x} = 3 \text{ or } 27$$

$$\Rightarrow 3^{4\sin^2 x} = 3^1 \text{ or } 3^3$$

$$\Rightarrow \sin^2 x = 1/4 \text{ or } 3/4$$

$$\Rightarrow \sin x = \pm 1/2 \text{ or } \pm \sqrt{3}/2$$

$$\Rightarrow x = \pi/6 \text{ or } \pi/3 \text{ or } 5\pi/6 \text{ or } 2\pi/3$$

11. In a triangle  $ABC$ , the angle  $B$  is greater than the angle  $A$ . If the values of angles  $A$  and  $B$  satisfy the equation  $3 \sin x - 4 \sin^3 x - k = 0$ ,  $0 < k < 1$ , then the values of  $C$  is

- (a)  $\pi/3$  (b)  $\pi/2$   
 (c)  $2\pi/3$  (d)  $5\pi/6$

**Solution:** (c) We have  $3 \sin x - 4 \sin^3 x = k$ ,  $0 < k < 1$ , which can also be written as  $\sin 3x = k$ . It is given that  $A$  and  $B$  are solution of this equation.

Therefore  $\sin 3A = k$  and  $\sin 3B = k$  (where  $0 < k < 1$ )  
 $\Rightarrow 0 < 3A < \pi$  and  $0 < 3B < \pi$  (since  $0 < k < 1$ )  
 $\Rightarrow 3A = 3B$  (which is not possible)  
 or  $3(A+B) = \pi \Rightarrow A+B = \pi/3 \Rightarrow C = 2\pi/3$

**Aliter:** Now  $\sin 3A - \sin 3B = 0$

$$\Rightarrow 2 \cos 3 \frac{(A+B)}{2} \sin 3 \frac{(A-B)}{2} = 0$$

But it is given that  $B > A$  and  $0 < 3A < \pi$ ,  $0 < 3B < \pi$

$$\therefore \sin \frac{3(A-B)}{2} \neq 0. \text{ Hence } \cos \frac{3(A+B)}{2} = 0$$

$$\Rightarrow A+B = \pi/3 \Rightarrow C = \pi - \pi/3 = 2\pi/3$$

12. The number of roots of the equation,  $\sin x + 2 \sin 2x = 3 + \sin 3x$  is:

- (a) 0 (b) 1  
 (c) 2 (d) infinite

**Solution:** (a)

$$\Rightarrow (\sin x - \sin 3x) + 2 \sin 2x = 3$$

$$\Rightarrow -2 \sin x \cos 2x + 2 \sin 2x = 3$$

$$\Rightarrow 2 \sin x \cos 2x - 2 \sin 2x + 3 = 0$$

$$\Rightarrow 2 \sin x \cos 2x - 2 \sin 2x + (\sin^2 x + \cos^2 x) + (\sin^2 2x + \cos^2 2x) + 1 = 0$$

$$\Rightarrow (1 - \sin 2x)^2 + (\sin x + \cos 2x)^2 + \cos^2 x = 0$$

Hence there is no root because all terms do not vanish simultaneously.

13. The number of the solutions of the equation

$$\sin \left( \frac{\pi x}{2\sqrt{3}} \right) = x^2 - 2\sqrt{3}x + 4$$

- (a) is zero (b) is only one  
 (c) only two (d) is more than two

**Solution:** (b) Given equation is

$$\sin \left( \frac{\pi x}{2\sqrt{3}} \right) = x^2 - 2\sqrt{3}x + 4$$

$$\Rightarrow \sin \left( \frac{\pi x}{2\sqrt{3}} \right) = (x - \sqrt{3})^2 + 1$$

So L.H.S.  $\leq 1$  while R.H.S.  $\geq 1$

Therefore equality holds iff  $x = \sqrt{3}$

14. If  $1 + |\sin x| + |\sin^2 x| + |\sin^3 x| + \dots = 4 + 2\sqrt{3}$  where  $x \in (0, \pi) \sim \{\pi/2\}$ , then the value of  $x$  is

- (a)  $\pi/6$  (b)  $\pi/3$   
 (c)  $2\pi/3$  (d)  $5\pi/6$

**Solution:** (b, c) Since for all  $x \in (0, \pi) \sim \pi/2$   
 $0 < \sin x < 1$

and equation becomes

$$1 + \sin x + \sin^2 x + \dots = 4 + 2\sqrt{3}$$

$$\Rightarrow \frac{1}{1 - \sin x} = 4 + 2\sqrt{3}$$

$$\Rightarrow 1 - \sin x = \frac{4 - 2\sqrt{3}}{4} = 1 - \frac{\sqrt{3}}{2}$$

$$\Rightarrow \sin x = \frac{\sqrt{3}}{2} = \sin \frac{\pi}{3}$$

$$\Rightarrow x = n\pi + (-1)^n \frac{\pi}{3}; \text{ where } n \in \mathbb{Z}$$

15. The equation  $\left( \cos \left( \frac{\sqrt{2}+1}{2} \theta \right) \right) \left( \cos \left( \frac{\sqrt{2}-1}{2} \theta \right) \right) = 1$  has

- (a) no solution (b) one solution  
 (c) many solution (d) None of these

**Solution:** (b) Here the equation becomes

$$\cos \left( \frac{\theta}{\sqrt{2}} + \frac{\theta}{2} \right) \cos \left( \frac{\theta}{\sqrt{2}} - \frac{\theta}{2} \right) = 1$$

$$\Rightarrow \cos^2 \frac{\theta}{\sqrt{2}} - \sin^2 \frac{\theta}{2} = 1$$

$$[\because \cos(A+B) \cos(A-B) = \cos^2 A - \sin^2 B]$$

Since  $0 \leq \cos^2 \frac{\theta}{\sqrt{2}} \leq 1 \Rightarrow \cos^2 \frac{\theta}{\sqrt{2}} = 1$ , and  $\sin^2 \frac{\theta}{2} = 0$

$$\Rightarrow \cos^2 \frac{\theta}{\sqrt{2}} = 1 \Rightarrow \cos \frac{\theta}{\sqrt{2}} = \pm 1 \Rightarrow \frac{\theta}{\sqrt{2}} = n\pi \dots (i)$$

$$\Rightarrow \sin^2 \frac{\theta}{2} = 0 \Rightarrow \sin \frac{\theta}{2} = 0 \Rightarrow \theta = 2k\pi \dots (ii)$$

(where  $n, k \in \mathbb{Z}$ )

From (i) and (ii) only common solution is for  $n = k = 0$   
 i.e.,  $\theta = 0$  is the only solution

16. If all the solutions 'x' of  $a^{\cos x} + a^{-\cos x} = 6$  ( $a > 1$ ) are real, then set of values of  $a$  is

- (a)  $[3 + 2\sqrt{2}, \infty)$  (b)  $(6, 12)$   
 (c)  $(1, 3 + 2\sqrt{2})$  (d) None of these

**Solution:** (a) Let  $a^{\cos x} = t \Rightarrow t + 1/t = 6$

$$\Rightarrow t^2 - 6t + 1 = 0$$

2.58 > Trigonometry

$$\Rightarrow t = \frac{6 \pm \sqrt{36-4}}{2} = 3 \pm 2\sqrt{2}$$

$$\Rightarrow a^{\cos x} = 3 \pm 2\sqrt{2}$$

$$\Rightarrow \cos x = \log_a(3 \pm 2\sqrt{2})$$

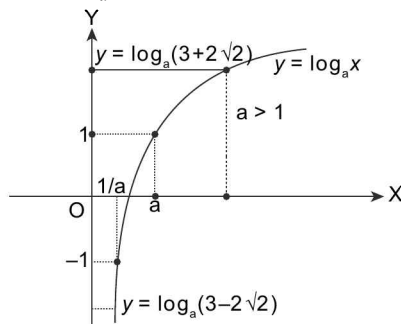

Since for all the roots to be real,  $a > 1$   
 So we must have  $\log_a(3 + 2\sqrt{2}) \leq 1$  and  
 $\log_a(3 - 2\sqrt{2}) \geq -1$ ,  
 Both are true for  $a \geq 3 + 2\sqrt{2}$

17. The number of the solutions of the equation  $x^3 + 2x^2 + 5x + 2\cos x = 0$  in  $[0, 2\pi]$  is  
 (a) 0 (b) 1  
 (c) 2 (d) 3

**Solution:** (a) Consider the function

$$y = x^3 + 2x^2 + 5x + 2\cos x$$

$$\Rightarrow \frac{dy}{dx} = 3x^2 + 6x + 5 - 2\sin x$$

$$\therefore \frac{dy}{dx} > 3x^2 + 6x + 3 = 3(x+1)^2 \geq 0$$

$$\Rightarrow \frac{dy}{dx} \geq 0 \text{ for all } x \in \mathbb{R}$$

Implies given function is monotonically increasing and value is 2 at  $x = 0$ , which is positive. So left hand side will be greater than 2 for all  $x \geq 0$ . So no root lies in  $[0, 2\pi]$ .

18.  $x_1$  and  $x_2$  are two positive values of  $x$  for which  $2 \cos x$ ,  $|\cos x|$  and  $3 \sin^2 x - 2$  are in G.P. The minimum value of  $|x_1 - x_2|$  is equal to  
 (a)  $4\pi/3$  (B)  $\pi/3$   
 (c)  $2 \cos^{-1}\left(\frac{2}{3}\right)$  (d)  $\cos^{-1}\left(\frac{2}{3}\right)$

**Solution:** (c)  $\cos^2 x = 2 \cos x(3 \sin^2 x - 2)$   
 $\Rightarrow \cos x[\cos x - 2\{3(1 - \cos^2 x) - 2\}] = 0$   
 $\Rightarrow \cos x(6 \cos^2 x - 2 + \cos x) = 0$   
 either,  $\cos x = 0$ , which is not possible  
 $[\because \text{no term in a GP can be equal to zero}]$   
 or  $6 \cos^2 x + \cos x - 2 = 0$

$$\Rightarrow \cos x = \frac{1}{2}, -\frac{2}{3}$$

$$\Rightarrow x = \frac{\pi}{3}, \frac{5\pi}{3}, \text{ or } x = \pi - \cos^{-1}\left(\frac{2}{3}\right) \text{ or}$$

$$\pi + \cos^{-1}\left(\frac{2}{3}\right)$$

$$\Rightarrow |x_1 - x_2| = \frac{4\pi}{3} \text{ or } |x_1 - x_2| = 2 \cos^{-1}\left(\frac{2}{3}\right)$$

$$\Rightarrow |x_1 - x_2|_{\min} = 2 \cos^{-1}\left(\frac{2}{3}\right);$$

$\therefore \frac{4\pi}{3} = 2 \cos^{-1}\left(-\frac{1}{2}\right)$  and  $\cos^{-1}x$  is a decreasing function

$$\Rightarrow 2 \cos^{-1}\left(-\frac{1}{2}\right) > 2 \cos^{-1}\left(\frac{2}{3}\right)$$

19. If the equation  $1 + \sin^2 x \theta = \cos \theta$  has non-zero solution in  $\theta$ , then  $x$  must be  
 (a) an integer  
 (b) a rational number  
 (c) an irrational number  
 (d) lying strictly between 0 and 1

**Solution:** (b) The given equation is  $1 + \sin^2 x \theta = \cos \theta$   
 or,  $1 - \cos \theta = \sin^2 x \theta \Rightarrow 2 \sin^2 \theta/2 = \sin^2 x \theta \dots(i)$   
 $\theta = 0$  is one solution

L.H.S. has period  $2\pi$  and R.H.S. has period  $\pi/x$ .  
 The solution other than zero exists iff LCM of  $2\pi$  and  $\pi/x$  exists. So  $x$  must be a rational number.

20. Total number of solutions of  $[\sin x] + \cos x = 0$  for  $x \in [0, 2\pi]$  is  
 (where  $[.]$  denotes the greatest integer function)  
 (a) 1 (b) 2  
 (c) 4 (d) 0

**Solution:** (d) Given equation is  $[\sin x] = -\cos x$   
 Real solution exists iff  $-\cos x$  is integer i.e.,  $\cos x$  is an integer.

So possible solutions for  $x \in [0, 2\pi]$  are  $x = 0, \pi/2, \pi, 3\pi/2, 2\pi$   
 when  $x = 0, 2\pi$  RHS = -1 and LHS = 0, no solution  
 $x = \pi/2$  or  $3\pi/2$  RHS = 0 and LHS = 1, no solution  
 $x = \pi$  RHS = 1 and LHS = 0, no solution  
 So, we can conclude that equations has no real solution.

21. Number of solutions to the equation  $|2e^{\sin x} - 3 - e^{2\sin x}| = |e^{\sin x} - e^{2\sin x} - 1|$  in  $[0, 2\pi]$  is  
 (a) zero (b) two  
 (c) four (d) None of these

**Solution: (b)** Let  $e^{\sin x} = t$  then  $|2t - 3 - t^2| = |t - t^2 - 1|$   
 $\Rightarrow |t^2 - 2t + 3| = |t^2 - t + 1|$   
 here  $t^2 - 2t + 3 > 0, t^2 - t + 1 > 0 \forall t \in \mathbb{R}$ . So,  
 $t^2 - 2t + 3 = t^2 - t + 1 \Rightarrow t = 2 \Rightarrow e^{\sin x} = 2$   
 $\Rightarrow \sin x = \ln 2 \in (0, 1)$   
 $\Rightarrow \ln[0, 2\pi]$  there will be two solutions.

22. Complete set of values of  $x$  in  $(0, \pi)$  satisfying  $1 + \log_2(\sin x) + \log_2(\sin 3x) \geq 0$  is

- (a)  $\left(\frac{2\pi}{3}, \frac{3\pi}{4}\right)$
- (b)  $\left(\frac{\pi}{3}, \frac{2\pi}{3}\right)$
- (c)  $\left[\frac{\pi}{6}, \frac{\pi}{4}\right] \cup \left[\frac{3\pi}{4}, \frac{5\pi}{6}\right]$
- (d)  $\left(\frac{\pi}{2}, \frac{2\pi}{3}\right)$

**Solution: (c)**  $1 + \log_2(\sin x) + \log_2(\sin 3x) \geq 0$

$\Rightarrow \sin x, \sin 3x > 0$   
 $\Rightarrow \log_2(2 \sin x \sin 3x) \geq 0$   
 $\Rightarrow 2 \sin x \sin 3x \geq 1$   
 For  $\sin x > 0 \Rightarrow x \in (0, \pi); \sin 3x > 0$   
 $\Rightarrow 3x \in (0, \pi) \cup (2\pi, 3\pi)$   
 $\Rightarrow x \in \left(0, \frac{\pi}{3}\right) \cup \left(\frac{2\pi}{3}, \pi\right)$  .....(i)

For  $2 \sin x \sin 3x \geq 1$   
 $\Rightarrow 2 \sin^2 x (3 - 4 \sin^2 x) \geq 1$   
 $\Rightarrow 8 \sin^4 x - 6 \sin^2 x + 1 \leq 0$   
 $\Rightarrow (2 \sin^2 x - 1)(4 \sin^2 x - 1) \leq 0$   
 $\Rightarrow \left(\sin x - \frac{1}{\sqrt{2}}\right)\left(\sin x + \frac{1}{\sqrt{2}}\right)$   
 $\left(\sin x - \frac{1}{2}\right)\left(\sin x + \frac{1}{2}\right) \leq 0$   
 $\Rightarrow \frac{1}{2} \leq \sin x \leq \frac{1}{\sqrt{2}}$   
 $\Rightarrow x \in \left[\frac{\pi}{6}, \frac{\pi}{4}\right] \cup \left[\frac{3\pi}{4}, \frac{5\pi}{6}\right]$  .....(ii)

In view of (i) and (ii),  $x \in \left[\frac{\pi}{6}, \frac{\pi}{4}\right] \cup \left[\frac{3\pi}{4}, \frac{5\pi}{6}\right]$

23. If  $\operatorname{cosec}(\theta - \alpha), \operatorname{cosec}\theta, \operatorname{cosec}(\theta + \alpha)$  are in A.P.  $\alpha \in (-\pi/2, \pi/2)$ , then the number of possible values of  $\alpha$  is  
 (a) 0 (b) 1  
 (c) 2 (d) None of these

**Solution: (b)**

$$\frac{2}{\sin \theta} = \frac{1}{\sin(\theta - \alpha)} + \frac{1}{\sin(\theta + \alpha)} = \frac{2 \sin \theta \cos \alpha}{\sin^2 \theta - \sin^2 \alpha}$$

$$\Rightarrow \sin^2 \theta \cos \alpha = \sin^2 \theta - \sin^2 \alpha$$

$$\Rightarrow \sin^2 \theta = \frac{\sin^2 \alpha}{1 - \cos \alpha} = 2 \cos^2 \alpha / 2 \text{ if } \alpha \neq 0.$$

$$\Rightarrow \cos^2 \alpha / 2 = \frac{1}{2} \sin^2 \theta \leq 1/2 \text{ but } -\pi/4 < \alpha/2 < \pi/4$$

$$\Rightarrow \cos^2(\alpha/2) \geq 1/2$$

$$\therefore \cos^2(\alpha/2) = 1/2 \Rightarrow \cos \alpha = 0$$

which is not true in  $\left(-\frac{\pi}{2}, \frac{\pi}{2}\right)$ .

If  $\alpha = 0$ , then  $\operatorname{cosec}(\theta - \alpha), \operatorname{cosec}\theta, \operatorname{cosec}(\theta + \alpha)$  are obviously in A.P.

Hence  $\alpha = 0$  is only possible value of  $\alpha$  in  $\left(-\frac{\pi}{2}, \frac{\pi}{2}\right)$ .

24. Find the number of solutions of the equation  $4e^{\sin x} - 3e^{-\sin x} + 4 = 0$  in  $[0, 2\pi]$

- (a) 1 (b) 2
- (c) 3 (d) None of these

**Solution:** Let us suppose  $e^{\sin x} = y$

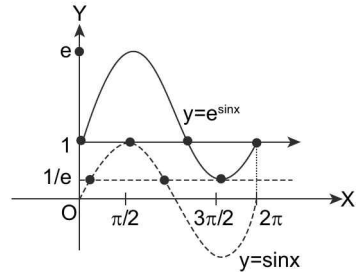

$$\Rightarrow 4y - 3/y + 4 = 0 \Rightarrow 4y^2 + 4y - 3 = 0$$

$$\Rightarrow 4y^2 + 6y - 2y - 3 = 0$$

$$\Rightarrow (2y - 1)(2y + 3) = 0$$

$$\Rightarrow y = 1/2 \text{ or } y = -3/2 \Rightarrow e^{\sin x} = 1/2$$

Now,  $-1 \leq \sin x \leq 1 \Rightarrow 1/e \leq e^{\sin x} \leq e$ .

$e^{\sin x}$  can never be negative hence no solution for  $y = -3/2$  and  $1/2 > 1/e \Rightarrow e^{\sin x} = \frac{1}{2}$  has two solutions in  $[0, 2\pi]$   
 $\Rightarrow$  No of solutions = 2

25. If  $\cos(\alpha - \beta) = 1$  and  $\cos(\alpha + \beta) = 1/e$ , where  $\alpha, \beta \in [-\pi, \pi]$ , then the number of pairs of  $\alpha, \beta$  which satisfy the above two equations is  
 (a) 0 (b) 1  
 (c) 2 (d) 4



2.60 > Trigonometry

**Solution: (d)**  $\alpha, \beta \in [-\pi, \pi] \Rightarrow \alpha - \beta$  and  $\alpha + \beta \in [-2\pi, 2\pi]$   
 $\cos(\alpha - \beta) = 1$  and  $\cos(\alpha + \beta) = 1/e$   
 $\Rightarrow \alpha - \beta = 0, 2\pi, -2\pi,$   
 $\Rightarrow \alpha = \beta$  or  $\alpha = \pi, \beta = -\pi,$  or  $\alpha = -\pi, \beta = \pi$   
 For  $\alpha = \beta, \cos 2\alpha = 1/e \Rightarrow 2\cos^2\alpha = 1/e + 1$   
 $\Rightarrow \cos^2\alpha = \frac{e+1}{2e} = k$  where  $k < 1$   
 $\Rightarrow \cos\alpha = \pm\sqrt{k}; \alpha \in [-\pi, \pi]$

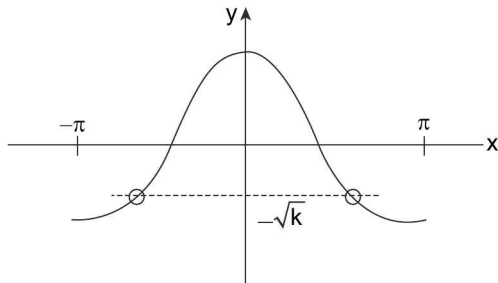
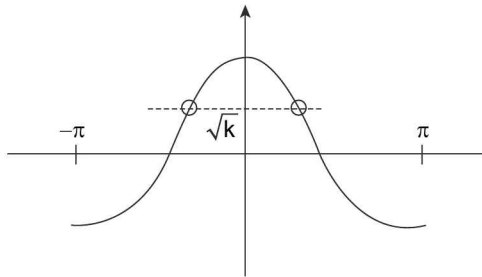

$\Rightarrow$  There will be four solution

26. The total number of roots of the equation  $3^{\cos x} = |\sin x|$ , belonging to  $[-4\pi, 4\pi]$  is  
 (a) 14 (b) 15  
 (c) 16 (d) None of these

**Solution: (c)**  $-1 \leq \cos x \leq 1$   
 $\Rightarrow 1/3 \leq 3^{\cos x} \leq 3$  and  $0 \leq |\sin x| \leq 1$   
 $\Rightarrow y = 3^{\cos x}$  and  $y = |\sin x|$  have intersecting range.  
 We draw the graphs of  $y = |\sin x|$  and  $y = 3^{\cos x}$  and compare.  $\therefore |\sin x| = 3^{\cos x}$  at  $x = (2n + 1)\pi/2$

We need to check whether the two graphs intersect or touch each other at  $x = \pi/2$  and that will determine whether  $(\pi/2, \pi)$  there exists a solution or not

For that we use calculus i.e., two curves touch each other at a point  $P$  if  $\left(\frac{dy_1}{dx}\right)_P = \left(\frac{dy_2}{dx}\right)_P$  and two curve

intersect at a point  $P$  when  $\left(\frac{dy_1}{dx}\right)_P \neq \left(\frac{dy_2}{dx}\right)_P$

Here  $\left(\frac{d(3^{\cos x})}{dx}\right)_{\pi/2} = 3^{\cos x}(-\sin x \cdot \log_e 3) = -\ln 3$

which is a negative given by

and  $\left(\frac{d|\sin x|}{dx}\right)_{\pi/2} = \frac{|\sin x|}{\sin x} \times \cos x = 0$

$\Rightarrow \left(\frac{dy_1}{dx}\right)_{\pi/2} \neq \left(\frac{dy_2}{dx}\right)_{\pi/2}$

$\Rightarrow$  There two graphs not only touch but cut each other at  $x = \pi/2$  and hence there will be 2 solutions in  $(0, \pi)$  as is clear from the graph given below.

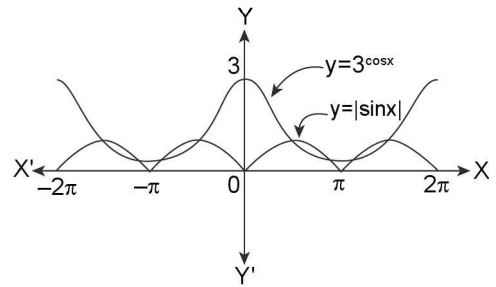

$\therefore$  Total number of solutions =  $8 \times 2 = 16$

**Matrix Match Type**

27. Column-I

- (a) If  $\alpha, \beta$  are the solutions of  $\sin x = -\frac{\sqrt{3}}{2}$  in  $[0, 2\pi]$  and  $\alpha, \gamma$  are the solutions of  $\cos x = -\frac{1}{2}$  in  $[0, 2\pi]$ , then  
 (b) If  $\alpha, \beta$  are the solutions of  $\cot x = -\frac{1}{\sqrt{3}}$  in  $[0, 2\pi]$  and  $\alpha, \beta$  are the solution of  $\operatorname{cosec} x = \frac{-2}{\sqrt{3}}$  in  $[0, 2\pi]$ , then  
 (c) If  $\alpha, \beta$  are the solutions of  $\sin x = -\frac{\sqrt{3}}{2}$  in  $[0, 2\pi]$  and  $\alpha, \gamma$  are the solutions of  $\tan x = \sqrt{3}$  in  $[0, 2\pi]$ , then

**Column-II**

- (p)  $\alpha - \beta = \pi$   
 (q)  $\beta - \gamma = \pi$   
 (r)  $\alpha - \gamma = \pi$   
 (s)  $\alpha + \beta = 3\pi$   
 (t)  $\beta + \gamma = 2\pi$

**Ans.** a  $\rightarrow$  (q, s); b  $\rightarrow$  (p, t); c  $\rightarrow$  (r,s,t)

**Solution: (a)**  $\therefore \sin x = -\frac{\sqrt{3}}{2} = -\sin \frac{\pi}{3}$   
 $= \sin\left(\pi + \frac{\pi}{3}\right), \sin\left(2\pi - \frac{\pi}{3}\right)$

$$\therefore x = \frac{4\pi}{3}, \frac{5\pi}{3} \quad \dots\dots(i)$$

$$\text{and } \cos x = -\frac{1}{2} = -\cos \frac{\pi}{3} \\ = \cos \left( \pi - \frac{\pi}{3} \right), \cos \left( \pi + \frac{\pi}{3} \right)$$

$$\therefore x = \frac{2\pi}{3}, \frac{4\pi}{3} \quad \dots\dots(ii)$$

From equation (i) and (ii), it is clear that

$$\alpha = \frac{4\pi}{3}, \beta = \frac{5\pi}{3}, \gamma = \frac{2\pi}{3} \\ \Rightarrow \beta - \gamma = \pi, \alpha + \beta = 3\pi$$

$$(b) \therefore \cot x = \frac{-1}{\sqrt{3}} = -\cot \frac{\pi}{3} \\ = \cot \left( \pi - \frac{\pi}{3} \right), \cot \left( 2\pi - \frac{\pi}{3} \right)$$

$$\therefore x = \frac{2\pi}{3}, \frac{5\pi}{3} \quad \dots\dots(i)$$

$$\text{and } \operatorname{cosec} x = \frac{-2}{\sqrt{3}} = -\operatorname{cosec} \frac{\pi}{3} \\ = \operatorname{cosec} \left( \pi + \frac{\pi}{3} \right), \operatorname{cosec} \left( 2\pi - \frac{\pi}{3} \right)$$

$$\therefore x = \frac{4\pi}{3}, \frac{5\pi}{3} \quad \dots\dots(ii)$$

From equation (i) and (ii), it is clear that

$$\alpha = \frac{5\pi}{3}, \beta = \frac{2\pi}{3}, \gamma = \frac{4\pi}{3} \therefore \beta + \gamma = 2\pi; \alpha - \beta = \pi$$

$$(c) \therefore \sin x = -\frac{\sqrt{3}}{2} = -\sin \frac{\pi}{3} \\ = \sin \left( \pi + \frac{\pi}{3} \right), \sin \left( 2\pi - \frac{\pi}{3} \right)$$

$$\therefore x = \frac{4\pi}{3}, \frac{5\pi}{3} \quad \dots\dots(i)$$

$$\text{and } \tan x = \sqrt{3} = \tan \frac{\pi}{3} = \tan \left( \pi + \frac{\pi}{3} \right)$$

$$\therefore x = \frac{\pi}{3}, \frac{4\pi}{3} \quad \dots\dots(ii)$$

From equation (i) and (ii), it is clear that

$$\alpha = \frac{4\pi}{3}, \beta = \frac{5\pi}{3}, \gamma = \frac{\pi}{3} \\ \Rightarrow \alpha + \beta = 3\pi, \alpha - \gamma = \pi, \beta + \gamma = 2\pi$$

- 28.** Solve the equations for 'x' given in Column-I and match with the entries of Column-II consists of set of values of x that satisfy the equations given in column-I

#### Column-I

- (a)  $\cos 3x \cdot \cos^3 x + \sin 3x \cdot \sin^3 x = 0$   
 (b)  $\sin 3\alpha = 4 \sin \alpha \sin(x + \alpha) \sin(x - \alpha)$

(c)  $|2 \tan x - 1| + |2 \cot x - 1| = 2.$

(d)  $\sin^{10} x + \cos^{10} x = \frac{29}{16} \cos^4 2x.$

#### Column-II

(p)  $n\pi \pm \frac{\pi}{3}; n \in \mathbb{Z}$

(q)  $n\pi + \frac{\pi}{4}, n \in \mathbb{Z}$

(r)  $\frac{n\pi}{4} \pm \frac{\pi}{8}, n \in \mathbb{Z}$

(s)  $\frac{n\pi}{2} \pm \frac{\pi}{4}; n \in \mathbb{Z}$

**Ans.** a  $\rightarrow$  (s); b  $\rightarrow$  (p); c  $\rightarrow$  (r)

**Solution:** (a)  $\cos 3x \cdot \cos^3 x + \sin 3x \cdot \sin^3 x = 0$   
 $\Rightarrow (4 \cos^3 x - 3 \cos x) \cos^3 x + (3 \sin x - 4 \sin^3 x) \sin^3 x = 0$   
 $\Rightarrow 4(\cos^6 x - \sin^6 x) - 3(\cos^4 x - \sin^4 x) = 0$   
 $\Rightarrow 4(\cos^6 x - \sin^6 x) - 3(\cos^2 x - \sin^2 x) = 0$   
 $\Rightarrow (\cos^2 x - \sin^2 x)(1 - 4 \cos^2 x \sin^2 x) = 0$   
 $\Rightarrow \cos 2x = 0$  or  $\sin^2 2x = 1 = \sin \pi/2$   
 $\Rightarrow 2x = 2n\pi \pm \pi/2$  or  $2x = n\pi \pm \pi/2$   
 $\Rightarrow x = n\pi \pm \pi/4$  or  $x = \frac{n\pi}{2} \pm \frac{\pi}{4}$

$\Rightarrow$  (q), (s)

(b)  $\sin 3\alpha = 4 \sin \alpha \sin(x + \alpha) \sin(x - \alpha)$

$$\Rightarrow \sin 3\alpha = 4 \sin \alpha \left[ \frac{\cos 2\alpha - \cos 2x}{2} \right]$$

$$\Rightarrow 3 \sin \alpha - 4 \sin^3 \alpha = 4 \sin \alpha \left[ \frac{\cos 2\alpha - \cos 2x}{2} \right]$$

( $\because \sin \alpha \neq 0$  if  $\alpha \neq n\pi$ )

$$\therefore 3 - 4 \sin^2 \alpha = 2 \cos 2\alpha - 2 \cos 2x \\ \Rightarrow 3 - 2(1 - \cos 2\alpha) = 2 \cos 2\alpha - 2 \cos 2x \\ \Rightarrow 3 - 2 + 2 \cos 2\alpha = 2 \cos 2\alpha - 2 \cos 2x \\ \Rightarrow \cos 2x = -1/2$$

$$x = n\pi \pm \frac{\pi}{3}$$

$\Rightarrow$  (p)

(c)  $|2 \tan x - 1| + |2 \cot x - 1| = 2$

$\Rightarrow$  sum of two non-negative quantities = 2

$\Rightarrow 2 \tan x - 1 = 1$

$\Rightarrow \tan x = 1$

$\Rightarrow x = n\pi + \pi/4$

$\Rightarrow$  (q)

(d)  $\sin^{10} x + \cos^{10} x = \frac{29}{16} \cos^4 2x$

$$\Rightarrow \left( \frac{1 - \cos 2x}{2} \right)^5 + \left( \frac{1 + \cos 2x}{2} \right)^5 = \frac{29}{16} \cos^4 2x$$

2.62 > Trigonometry

$$\begin{aligned} & \frac{1}{16}(1+10\cos^2 2x+5\cos^4 2x) = \frac{29}{16}\cos^4 2x \\ \Rightarrow & 24\cos^4 2x - 10\cos^2 2x - 1 = 0 \\ \Rightarrow & (12\cos^2 2x + 1)(2\cos^2 2x - 1) = 0 \\ \Rightarrow & \cos^2 2x = \frac{1}{2} \text{ or } \cos^2 2x = \cos^2\left(\frac{\pi}{4}\right) \\ \Rightarrow & 2x = n\pi \pm \frac{\pi}{4} \text{ or } x = \frac{n\pi}{2} \pm \frac{\pi}{8} \\ \Rightarrow & \text{(r)} \end{aligned}$$

**Solved Comprehension Passage**

**Passage 1:**

Let  $S_1$  be the set of all those solutions of the equation  $(1+a)\cos x \cdot \cos(2x-b) = (1+a\cos 2x)\cos(x-b)$  which are independent of 'a' and 'b'. And let  $S_2$  be the set of all other solutions of the above equation. Then on the basis of the above information provided above, answer the questions that follow:

29. Set  $S_2$  is given by:

- (a)  $\frac{1}{2}(n\pi + b + (-1)^n \sin^{-1}(a \sin b))$ ;  $n \in \mathbb{Z}$
- (b)  $\frac{1}{2}(n\pi + a + (-1)^n \sin^{-1}(a \sin b))$ ;  $n \in \mathbb{Z}$
- (c)  $\frac{1}{2}(n\pi + b + (-1)^n \sin^{-1}(b \sin a))$ ;  $n \in \mathbb{Z}$
- (d)  $\frac{1}{2}(n\pi + a + (-1)^n \sin^{-1}(b \sin a))$ ;  $n \in \mathbb{Z}$

30. Conditions that should be imposed on 'a' and 'b' such that  $S_2$  is non-empty is

- (a)  $|b \sin a| \leq 1$                       (b)  $|b \sin a| = 1$
- (c)  $|a \sin b| \leq 1$                       (d) None of these

31. All the permissible values of 'b', if  $a = 0$  and  $S$  is subset of  $(0, \pi)$ .

- (a)  $b \in (-n\pi, 2\pi - n\pi)$ , where  $n \in \mathbb{Z}$
- (b)  $b \in (n\pi, 2\pi + n\pi)$ , where  $n \in \mathbb{Z}$
- (c)  $b \in (2n\pi, 2\pi + n\pi)$ , where  $n \in \mathbb{Z}$
- (d)  $b \in (n\pi, 2\pi - n)$ , where  $n \in \mathbb{Z}$

**Solution:**

The given equation is:  $(1+a)\cos x \cdot \cos(2x-b) = (1+a\cos 2x)\cos(x-b)$

$$\begin{aligned} \Rightarrow & (\cos x \cdot \cos(2x-b) - \cos(x-b)) = a(\cos 2x \cdot \cos(x-b) - \cos x \cos(2x-b)) \\ \Rightarrow & \cos(3x-b) + \cos(x-b) - 2\cos(x-b) = a(\cos(3x-b) + \cos(x+b) - \cos(3x-b) - \cos(x-b)) \\ \Rightarrow & \cos(3x-b) - \cos(x-b) = a(\cos(x+b) - \cos(x-b)) \\ \Rightarrow & -2\sin(2x-b)\sin x = -2a\sin x \sin b \end{aligned}$$

$$\begin{aligned} \Rightarrow & \sin x [\sin(2x-b) - a \sin b] = 0 \\ \Rightarrow & \sin x = 0 \text{ or } \sin(2x-b) = a \sin b \end{aligned}$$

29. (a)  $S_1 = n_1\pi, S_2 = \frac{1}{2}(n\pi + b + (-1)^n \sin^{-1}(a \sin b))$

30. (c)  $S_2$  is non-empty if  $|a \sin b| \leq 1$

31. (a)  $a = 0$ , and have to make sure that  $0 < \frac{1}{2}(n\pi + (-1)^n \sin^{-1}(a \sin b) + b) < \pi$

$$\Rightarrow 0 < \frac{n\pi}{2} + \frac{b}{2} < \pi \Rightarrow -n\pi < b < 2\pi - n\pi$$

$$\Rightarrow b \in (-n\pi, 2\pi - n\pi), n \in \mathbb{Z}$$

**Passage 2:**

Let  $f(\theta)$  be defined as

$$f(\theta) = \begin{vmatrix} 1 + \sin^2 \theta & \cos^2 \theta & 4 \sin 4\theta \\ \sin^2 \theta & 1 + \cos^2 \theta & 4 \sin 4\theta \\ \sin^2 \theta & \cos^2 \theta & 1 + 4 \sin 4\theta \end{vmatrix}$$

Let  $p, q$  and  $r$  are smallest positive integers such that  $p < q$  and  $\{p\pi/r, q\pi/r\}$  be the solution set of  $f(\theta) = 0$ . Also, let  $a, b$  and  $c$  be three positive integers such that  $\frac{(ap+bq)}{cr} = k$  where 'k' is also an integer. Then on the basis of the information given above, answer the questions that follow.

32. What is the value of the ordered triplet (p,q,r)?

- (a) (3,4,8)                                      (b) (7,9,24)
- (c) (7,11,16)                                (d) (7,11,24)

33. What is the minimum value of  $a + b + c$ ?

- (a) 11    (b) 16
- (c) 14    (d) None of these

34. The total number of ordered pairs of (a, b) where  $k = c = 3$  is

- (a) 2    (b) 3
- (c) 4    (d) None of these

**Solution:** (d); (a); (b)

On solving the determinant equation  $f(\theta) = 0$ , we get the equation  $\sin 4\theta = -1/2$

And hence the value of  $\theta = \{7\pi/24, 11\pi/24\}$ . Hence, we get the values of  $p = 7, q = 11$  and  $r = 24$ .

$$\text{Now, we get } \frac{(ap+bq)}{cr} = \frac{(7a+11b)}{24c} = k; k \in \mathbb{Z}$$

The above expression can take the minimum value 1, and logically thinking we can also conclude that the minimum value of  $a + b + c$  will be achieved when

$$\frac{(7a+11b)}{24c} = 1 \text{ i.e., the numerator} = \text{denominator.}$$

Now considering the case when  $c = 1$ , there is no positive integral values of  $a$  and  $b$ .

When  $c = 2$ , again no positive integral values of  $a$  and  $b$ .

When  $c = 3$ ,  $24c = 72$  or  $7a + 11b = 72$  or

$a = 4$  and  $b = 4$  or  $a + b + c = 11$

When  $c = 4$ ,  $24c = 96 = 7a + 11b$ .

$\Rightarrow a = 9$  and  $b = 3$ .

$\Rightarrow a + b + c = 16$

When  $c = 5$ ,  $24c = 120 = 7a + 11b$

$\Rightarrow a = 3$  and  $b = 9$ .

$\Rightarrow a + b + c = 17 \Rightarrow$  Minimum value of  $a + b + c$  is 11

(i) When  $k = c = 3$ ,

$\Rightarrow 7a + 11b = 216$ .

Now,  $a = \frac{216 - 11b}{7}$  and for 'a' to be a positive integer, we must have 'b' = 5 or 12 or 19. Hence, 3 possible ordered pairs of (a, b).

**Passage 3:**

Let  $f(x)$  and  $g(x)$  be two functions where  $f(x) = \max. \{1 + \sin x, 1 - \cos x, 1\} \forall x \in [0, 2\pi]$  and  $g(x) = \max. \{1, |x - 1|\} \forall x \in \mathbb{R}$ . Now on the basis of the above information, answer the questions that follow.

- 35. Which of the statements is correct for  $g\{f(x)\}$ ?
  - (a)  $g\{f(x)\} = 0$  at exactly two points in its domain.
  - (b) The domain of  $g\{f(x)\}$  is  $[0, 2\pi]$ .
  - (c)  $g\{f(x)\} = 1$  for all  $x$  in its domain.
  - (d)  $g\{f(x)\}$  is defined for  $x \in \mathbb{R}$
- 36. What is the domain of  $f\{g(x)\}$ ?
  - (a)  $1 - 2\pi \leq x \leq 1 + 3\pi/2$
  - (b)  $1 - 2\pi \leq x \leq 1 - \pi/2$
  - (c)  $1 - 2\pi \leq x \leq 1 + 2\pi$
  - (d) None of these
- 37. What are the values of  $x$  for which  $f\{g(x)\} = 1$ ?
  - (a)  $1 - 2\pi \leq x \leq 1 - 3\pi/2$
  - (b)  $x = 1 - 3\pi/8$
  - (c)  $1 + 3\pi/2 \leq x \leq 2\pi + 1$
  - (d)  $x = 6.5$

**Solution: (b)(c); (c); (a)(c)** Here,  $f(x) = \max. \{1 + \sin x, 1 - \cos x, 1\}$  graphically it can be shown as:

$$f(x) = \begin{cases} 1 + \sin x, & 0 \leq x \leq \frac{3\pi}{4} \\ 1 - \cos x, & \frac{3\pi}{4} < x \leq \frac{3\pi}{2} \\ 1, & \frac{3\pi}{2} < x \leq 2\pi \end{cases} \text{ [using the graph}$$

given below]

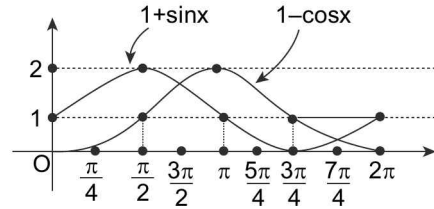

Again,  $g(x) = \max. \{1, |x - 1|\}$ , graphically it can be shown as,

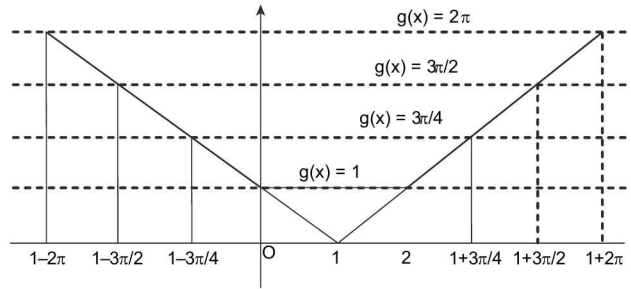

$$\therefore g(x) = \begin{cases} 1 - x, & x \leq 0 \\ 1, & 0 < x \leq 2 \\ x - 1, & x > 2 \end{cases}$$

$\Rightarrow g\{f(x)\} \neq 0 \forall x \in [0, 2\pi]$

$$\text{Now, } g\{f(x)\} = \begin{cases} 1 - f(x), & f(x) \leq 0 \\ 1, & 0 < f(x) \leq 2 \\ f(x) - 1, & f(x) > 2 \end{cases}$$

$$\text{Therefore, } g\{f(x)\} - 1 = \begin{cases} -f(x), & f(x) \leq 0 \\ 0, & 0 < f(x) \leq 2 \\ f(x) - 2, & f(x) > 2 \end{cases}$$

Since,  $f(x) \in [1, 2], \forall x \in [0, 2\pi]$

$$g(f(x)) = 1 \forall x \in [0, 2\pi]$$

$$\text{also, } f\{g(x)\} = \begin{cases} 1 + \sin\{g(x)\}, & 0 \leq g(x) \leq \frac{3\pi}{4} \\ 1 - \cos\{g(x)\}, & \frac{3\pi}{4} < g(x) \leq \frac{3\pi}{2} \\ 1, & \frac{3\pi}{2} < g(x) \leq 2\pi \end{cases}$$

Therefore,

$$f(g(x)) = \begin{cases} 1, & 1-2\pi \leq x < 1-3\pi/2 \\ 1-\cos(1-x), & 1-3\pi/2 \leq x < 1-3\pi/4 \\ 1+\sin(1-x), & 1-3\pi/4 \leq x \leq 0 \\ 1+\sin 1, & 0 < x \leq 2 \\ 1+\sin(x-1), & 2 < x \leq 1+3\pi/4 \\ 1-\cos(x-1), & 1+3\pi/4 < x \leq 1+3\pi/2 \\ 1, & 1+3\pi/2 < x \leq 2\pi+1 \end{cases}$$

$$\Rightarrow f(g(x))-1 = \begin{cases} 0, & 1-2\pi \leq x < 1-3\pi/2 \\ -\cos(1-x), & 1-3\pi/2 \leq x < 1-3\pi/4 \\ \sin(1-x), & 1-3\pi/4 \leq x \leq 0 \\ \sin 1, & 0 < x \leq 2 \\ \sin(x-1), & 2 < x \leq 1+3\pi/4 \\ -\cos(x-1), & 1+3\pi/4 < x \leq 1+3\pi/2 \\ 0, & 1+3\pi/2 < x \leq 2\pi+1 \end{cases}$$

Also, from the graph of  $f\{g(x)\}$ , we can easily see the points where  $f\{g(x)\} = 1$ .

### SECTION-III

#### OBJECTIVE TYPE (ONLY ONE CORRECT ANSWER)

- If  $\tan\theta + \tan(\pi/2 + \theta) = 0$ , then the most general value of  $\theta$  is (where  $n \in \mathbb{Z}$ ).  
 (a)  $n\pi \pm \frac{\pi}{4}$  (b)  $2n\pi + \frac{\pi}{4}$   
 (c)  $2n\pi \pm \frac{\pi}{4}$  (d)  $\frac{n\pi}{4} + (-1)^n \frac{\pi}{2}$
- The number(s) of solution of the equation  $2(\sin^4 2x + \cos^4 2x) + 3\sin^2 x \cos^2 x = 0$  is  
 (a) 0 (b) 1  
 (c) 2 (d) 3
- If  $2 \sin x + 1 \geq 0$  and  $x \in [0, 2\pi]$ , then the solution set for  $x$  is  
 (a)  $[0, 7\pi/6]$  (b)  $[0, 7\pi/6] \cup [11\pi/6, 2\pi]$   
 (c)  $[11\pi/6, 2\pi]$  (d) None of these
- The value of the given equation:  
 $\cos y \cdot \cos\left(\frac{\pi}{2} - x\right) - \cos x \cos\left(\frac{\pi}{2} - y\right) +$   
 $\sin y \cos\left(\frac{\pi}{2} - x\right) + \cos x \sin\left(\frac{\pi}{2} - y\right)$  is zero if  
 (a)  $x = 0$  (b)  $y = 0$   
 (c)  $x = y$  (d)  $x = n\pi - \pi/4 + y; n \in \mathbb{Z}$
- If  $\sin(x - y) = \cos(x + y) = 1/2$ , then the values of  $x$  and  $y$  lying between  $0^\circ$  and  $180^\circ$  are  
 (a)  $x = 45^\circ, y = 15^\circ$  (b)  $x = 45^\circ, y = 135^\circ$   
 (c)  $x = 165^\circ, y = 15^\circ$  (d)  $x = 165^\circ, y = 135^\circ$
- The number of roots of the equation  $x \sin x = 1$  in the interval  $0 < x < 2\pi$  is  
 (a) 0 (b) 1  
 (c) 2 (d) 4
- If  $\sin 2\theta = \cos 3\theta$ . The number of elements for the set  $\theta$  in  $0 \leq \theta \leq 2\pi$  is  
 (a) 2 (b) 5  
 (c) 6 (d) 12
- Total no. of solutions of  $[\sin x] + \cos x = 0$ ; where  $[.]$  denotes the greatest integer function,  $\cos x \in [0, 2\pi]$  is  
 (a) 1 (b) 2  
 (c) 4 (d) 0
- The most general solution of  $\tan\theta = -1$  and  $\cos\theta = 1/\sqrt{2}$  is  
 (a)  $n\pi + 7\pi/4$  (b)  $n\pi + (-1)^n \frac{7\pi}{4}$   
 (c)  $2n\pi + \frac{7\pi}{4}$  (d) None of these
- The number of solutions of the equation  $8\tan^2\theta + 9 = 6\sec\theta$  in the interval  $(-\pi/2, \pi/2)$  is  
 (a) two (b) four  
 (c) zero (d) None of these
- The number of solutions of  $|\cos x| = \sin x, 0 \leq x \leq 4\pi$  is  
 (a) 4 (b) 6  
 (c) 8 (d) 10
- The equation  $\cos^8 x + b \cos^4 x + 1 = 0$  will have a solution if  $b$  belongs to  
 (a)  $(-\infty, 2]$  (b)  $[2, \infty)$   
 (c)  $(-\infty, -2]$  (d) None of these
- If  $x_i \geq 0$  for  $1 \leq i \leq n$  and  $x_1 + x_2 + x_3 + \dots + x_n = \pi$  then the greatest value of the sum  $\sin x_1 + \sin x_2 + \dots + \sin x_n$  is  
 (a)  $n$  (b)  $\pi$   
 (c)  $n \sin(\pi/n)$  (d) None of these

14. The general solution of the equation

$$\frac{1 - \sin x + \dots + (-1)^n \sin^n x + \dots}{1 + \sin x + \dots + \sin^n x + \dots} = \frac{1 - \cos 2x}{1 + \cos 2x} \text{ is}$$

- (a)  $(-1)^n \frac{\pi}{3} + n\pi$       (b)  $(-1)^n \frac{\pi}{6} + n\pi$   
 (c)  $(-1)^{n+1} \frac{\pi}{6} + n\pi$       (d)  $(-1)^{n-1} \frac{\pi}{3} + n\pi$
15. If  $|\sin x + \cos x| = |\sin x| + |\cos x|$ , then  $x$  belongs to the quadrant  
 (a) I or III      (b) II or IV  
 (c) I or II      (d) III or IV
16. The equation  $\sin x (\sin x + \cos x) = k$  has real solutions, then  
 (a)  $0 \leq k \leq \frac{1+\sqrt{2}}{2}$       (b)  $2 - \sqrt{3} \leq k \leq 2 + \sqrt{3}$   
 (c)  $0 \leq k \leq 2 - \sqrt{3}$       (d)  $\frac{1-\sqrt{2}}{2} \leq k \leq \frac{1+\sqrt{2}}{2}$
17. The equation  $k \cos x - 3 \sin x = k + 1$  is solvable only if  $k$  belongs to the interval  
 (a)  $[4, \infty)$       (b)  $[-4, 4]$   
 (c)  $(-\infty, 4]$       (d) None of these
18. The number of real solutions of  $\sin e^x \cos e^x = 2^{x-2} + 2^{-x-2}$  is  
 (a) zero      (b) one  
 (c) two      (d) infinite
19. Let  $[x]$  be the greatest integer less than or equal to  $x$  and let  $f(x) = \sin x + \cos x$ . Then the most general solutions of  $f(x) = [f(\pi/10)]$  are  
 (a)  $2n\pi \pm \frac{\pi}{2}, n \in \mathbb{Z}$       (b)  $n\pi, n \in \mathbb{Z}$   
 (c)  $2n\pi, n \in \mathbb{Z}$       (d)  $2n\pi, 2n\pi + \pi/2, n \in \mathbb{Z}$
20.  $\sin x + \sin y = y^2 - y + a$  will have no solution in  $x$  and  $y$  if  $a$  belongs to  
 (a)  $(0, \sqrt{3})$       (b)  $(\sqrt{3}, 0)$   
 (c)  $(-\infty, -\sqrt{3})$       (d)  $(\sqrt{2} + 1/4, \infty)$
21. If  $x \cos \alpha + y \sin \alpha = 2a, x \cos \beta + y \sin \beta = 2a$ , then  $\frac{\sin 2\beta - \sin 2\alpha}{\cos^2 \alpha - \cos^2 \beta} =$   
 (a)  $\frac{4xy}{x^2 + y^2}$       (b)  $\frac{x^2 - y^2}{xy}$   
 (c)  $\frac{4ay}{x^2 + y^2}$       (d)  $\frac{4a^2 - x^2}{x^2 + y^2}$
22. The solution set of  $(2\cos x - 1)(3 + 2\cos x) = 0$  in the interval  $0 \leq x \leq 2\pi$  is  
 (a)  $\{\pi/3\}$   
 (b)  $\{\pi/3, 5\pi/3\}$

(c)  $\left\{ \frac{\pi}{3}, \frac{5\pi}{3}, \cos^{-1} \left( -\frac{3}{2} \right) \right\}$

- (d) None of these
23. The number of values of  $x$  in  $[0, 5\pi]$  satisfying the equation  $3 \cos 2x - 10 \cos x + 7 = 0$  is  
 (a) 5      (b) 6  
 (c) 8      (d) 10
24. The number of the solutions of the equation  $\tan x + \sec x = 2 \cos x$  lying in the interval  $[0, 2\pi]$  is  
 (a) 0      (b) 1  
 (c) 2      (d) 3
25. The equation  $(\cos p - 1)x^2 + (\cos p)x + \sin p = 0$  where  $x$  is a variable, has real roots. Then the interval of  $p$  may be  
 (a)  $(0, 2\pi)$       (b)  $(-\pi, 0)$   
 (c)  $(-\pi/2, \pi/2)$       (d)  $(0, \pi)$
26. The value of  $y$  for which the equation  $4 \sin x + 3 \cos x = y^2 - 6y + 14$  has real solution is  
 (a) 3      (b) 5  
 (c) -3      (d) None of these
27. The set of all values of  $x$  in the interval  $[0, \pi]$  for which  $2 \sin^2 x - 3 \sin x + 1 \geq 0$  is  
 (a)  $[0, \pi/6]$       (b)  $[5\pi/6, \pi]$   
 (c)  $[2\pi/3, \pi]$       (d)  $[0, \pi/6] \cup [5\pi/6, \pi] \cup \{\pi/2\}$
28. The general solution of the equation:  $\tan^2 \alpha + 2\sqrt{3} \tan \alpha = 1$  is given by: ( $n \in \mathbb{Z}$ )  
 (a)  $\alpha = \frac{n\pi}{2}$       (b)  $\alpha = (2n+1) \frac{\pi}{2}$   
 (c)  $\alpha = (6n+1) \frac{\pi}{12}$       (d)  $\alpha = n \frac{\pi}{12}$
29. If  $x \in \left[ 0, \frac{\pi}{2} \right]$ , the number of solutions of the equation,  $\sin 7x + \sin 4x + \sin x = 0$  is  
 (a) 3      (b) 5  
 (c) 6      (d) None of these
30. The general values of  $x$  for which  $\cos 2x, 1/2$  and  $\sin 2x$  are in A.P. are given by  
 (a)  $n\pi, n\pi + \frac{\pi}{2}$       (b)  $n\pi$   
 (c)  $n\pi + \pi/4$       (d)  $n\pi, n\pi + \frac{\pi}{4}$
31. One of the solution of  $\sin x + \sin 5x = \sin 2x + \sin 4x$  is:  
 (a)  $\frac{n\pi}{3}; n \in \mathbb{Z}$       (b)  $\frac{2n\pi}{3}; n \in \mathbb{Z}$   
 (c)  $n\pi; n \in \mathbb{Z}$       (d)  $2n\pi/5; n \in \mathbb{Z}$

2.66 > Trigonometry

32. Consider the equation  $\sin 3\alpha = 4\sin\alpha \cdot \sin(x + \alpha) \sin(x - \alpha)$ ,  $\alpha \in (0, \pi)$  and  $x \in (0, 2\pi)$ , then equation has  
 (a) no solution in II quadrant  
 (b) no solution in III quadrant  
 (c) one solution in each quadrant  
 (d) None of these
33. If  $0 \leq a \leq 3$ ,  $0 \leq b \leq 3$  and the equation  $x^2 + 4 + 3\cos(ax + b) = 2x$  has at least one solution, then  $(a + b)$  is equal to  
 (a) 0 (b)  $\pi/2$   
 (c)  $\pi$  (d) None of these
34. The general solution of  $\sin x - 3\sin 2x + \sin 3x = \cos x - 3\cos 2x + \cos 3x$  is ( $n \in \mathbb{Z}$ )  
 (a)  $n\pi + \frac{\pi}{8}$  (b)  $\frac{n\pi}{2} + \frac{\pi}{8}$   
 (c)  $(-1)^n \cdot \frac{n\pi}{2} + \frac{\pi}{8}$  (d)  $2n\pi + \cos^{-1} \frac{3}{2}$
35. If  $\tan \theta_1, \tan \theta_2, \tan \theta_3, \tan \theta_4$  are the roots of the equation  $x^4 - x^3 \sin 2\beta + x^2 \cos 2\beta - x \cos \beta - \sin \beta = 0$ , then  $\tan(\theta_1 + \theta_2 + \theta_3 + \theta_4)$  is  
 (a)  $\sin \beta$  (b)  $\cos \beta$   
 (c)  $\tan \beta$  (d)  $\cot \beta$
36. Exhaustive set to values of  $x$  satisfying  $|\cos 3x + \sin 3x| = |\cos 3x| + |\sin 3x|$  in  $[0, \pi/2]$  is  
 (a)  $[0, \pi/6]$  (b)  $[0, \pi/2]$   
 (c)  $[0, \pi/2] - (\pi/6, \pi/3)$  (d)  $[0, \pi/2] - (\pi/4, \pi/3)$
37. If  $f(x) = [\cos x \cos(x + 2) - \cos^2(x + 1)]$ , where  $[.]$  denotes the greatest integer function  $\leq x$ . Then solution of the equation  $f(x) = x$  is  
 (a) 1 (b) -1  
 (c) 0 (d) None of these
38. All solutions of the equation  $2 \sin \theta + \tan \theta = 0$  are obtained by taking all integral values of  $m$  and  $n$  is  
 (a)  $2n\pi + \frac{2\pi}{3}$  (b)  $n\pi$  and  $2m\pi \pm \frac{2\pi}{3}$   
 (c)  $n\pi$  and  $m\pi \pm \frac{\pi}{3}$  (d)  $n\pi$  and  $2m\pi \pm \frac{\pi}{3}$
39. The number of solutions of the equation  $x^3 + 2x^2 + 5x + 2\cos x = 0$  in  $[0, 2\pi]$  is  
 (a) 0 (b) 1  
 (c) 2 (d) 3
40. The number of solutions of the equation  $\sin^5 x - \cos^5 x = \frac{1}{\cos x} - \frac{1}{\sin x}$  ( $\sin x \neq \cos x$ ) is  
 (a) 0 (b) 1  
 (c) infinite (d) None of these
41.  $\tan(p\pi/4) = \cot(q\pi/4)$  if  
 (a)  $p + q = 0$  (b)  $p + q = 2n + 1$   
 (c)  $p + q = 2n$  (d)  $p + q = 2(2n + 1)$
42. If  $\sin x = \cos y$ , and  $\sqrt{6} \sin y \tan z$ ;  $2\sin z = \sqrt{3} \cos x$ ;  $u, v, w$  denotes respectively  $\sin^2 x, \sin^2 y, \sin^2 z$ , then the value of the triplet  $(u, v, w)$  is  
 (a) (1, 0, 0) (b) (0, 1, 0)  
 (c) (1/2, 1/2, 3/4) (d) (1/2, 3/4, 1/2)
43.  $\cos 2x - 3\cos x + 1 = \frac{1}{(\cot 2x - \cot x)\sin(x - \pi)}$  holds if  
 (a)  $\cos x = 0$  (b)  $\cos x = 1$   
 (c)  $\cos x = 5/2$  (d) for no real value of  $x$
44. The value of  $a$  for which the equation  $4 \operatorname{cosec}^2[\pi(a + x)] + a^2 - 4a = 0$  has a real solution is  
 (a)  $a = 1$  (b)  $a = 2$   
 (c)  $a = 3$  (d) None of these
45. Total number of solutions of  $\sin x \cdot \tan^4 x = \cos x$  belonging to  $(0, 4\pi)$  are  
 (a) 4 (b) 7  
 (c) 8 (d) None of these
46. The general solution of the inequation  $\log_{\tan x}(\sin x) > 0$  is  
 (a)  $\bigcup_{n \in \mathbb{Z}} \left( 2n\pi, 2n\pi + \frac{\pi}{2} \right)$  (b)  $\bigcup_{n \in \mathbb{Z}} \left( 2n\pi, 2n\pi + \frac{\pi}{4} \right)$   
 (c)  $\bigcup_{n \in \mathbb{Z}} (2n\pi, (2n+1)\pi)$  (d) None of these
47. If  $f(x) = [\cos x] + [\sin x + 1] = 0$ , (where  $[.]$  denotes the greatest integer function), then value of  $x$  satisfying  $f(x) = 0$ , where  $x \in [0, 2\pi]$ .  
 (a)  $x \in (\pi/2, \pi] \cup [3\pi/2, 2\pi)$   
 (b)  $x \in (0, \pi/2)$   
 (c)  $x \in [\pi/2, \pi] \cup [3\pi/2, 2\pi]$   
 (d)  $x \in [\pi, 2\pi]$
48. The equation  $\cos^4 x - \sin^4 x + \cos 2x + \alpha^2 + \alpha = 0$  will have at least one solution if  
 (a)  $-2 \leq \alpha \leq 2$  (b)  $-3 \leq \alpha \leq 1$   
 (c)  $-2 \leq \alpha \leq 1$  (d)  $-1 \leq \alpha \leq 2$
49. If  $\sin(\pi \cos \theta) = \cos(\pi \sin \theta)$ , then  $\sin 2\theta$  is  
 (a) 3/4 (b) 1/4  
 (c) -3/4 (d) None of these
50.  $6 \tan^2 x - 2\cos^2 x = \cos 2x$  if  
 (a)  $\cos 2x = -1$  (b)  $\cos 2x = 1$   
 (c)  $\cos 2x = -1/2$  (d)  $\cos 2x = 1/2$

## SECTION-IV

### OBJECTIVE TYPE (MORE THAN ONE CORRECT ANSWERS)

1. All values of  $x \in \left(0, \frac{\pi}{2}\right)$  such that  $\frac{\sqrt{3}-1}{\sin x} + \frac{\sqrt{3}+1}{\cos x} = 4\sqrt{2}$  are
- (a)  $\frac{\pi}{15}$  (b)  $\frac{\pi}{12}$   
 (c)  $\frac{11\pi}{36}$  (d)  $\frac{3\pi}{10}$
2. If  $\sin x + \cos x = \sqrt{y + \frac{1}{y}}$  for  $x \in [0, \pi]$ , then
- (a)  $x = \frac{\pi}{4}$  (b)  $y = 0$   
 (c)  $y = 1$  (d)  $x = \frac{3\pi}{4}$
3. If the equation  $\sin^2 x - a \sin x + b = 0$  has only one solution in  $(0, \pi)$ , then which of the following statements are correct?
- (a)  $a \in (-\infty, 1] \cup [2, \infty)$   
 (b)  $b \in (-\infty, 0] \cup [1, \infty)$   
 (c)  $a = 1 + b$   
 (d) All of the above
4. The solution of the equation  $|x^2 - 1 + \sin x| = |x^2 - 1| + |\sin x|$  belonging to the interval  $[-2\pi, 2\pi]$  may lie in the interval.
- (a)  $[2, \pi]$  (b)  $[-2\pi, -\pi]$   
 (c)  $[-1, -1/2]$  (d) None of these
5. The coordinates of the points of intersection of the curves  $y = \cos x$ ,  $y = \sin 3x$ , if  $-\pi/2 \leq x \leq \pi/2$  are
- (a)  $\left(\frac{-3\pi}{8}, \frac{1}{2}\sqrt{(2-\sqrt{2})}\right)$   
 (b)  $\left(\frac{\pi}{8}, \frac{1}{2}\sqrt{(2-\sqrt{2})}\right)$   
 (c)  $\left(\frac{\pi}{8}, \frac{1}{2}\sqrt{(2+\sqrt{2})}\right)$   
 (d)  $\left(\frac{\pi}{4}, \frac{1}{\sqrt{2}}\right)$
6. One of the solutions of the equation  $4 \sin x + 2 \cos x = 2 + 3 \tan x$  is
- (a)  $2n\pi$  (b)  $n\pi + (-1)^n \pi/6$   
 (c)  $2n\pi - \tan^{-1}(4/3)$  (d)  $2n\pi + \tan^{-1}(4/3)$
7. If  $\alpha > \beta > \gamma > \delta$  are four solution of the equations  $2^{|\sin x|} = 4^{|\cos x|}$  in  $[0, 2\pi]$ , then
- (a)  $\beta + \gamma = 2\pi$  (b)  $\gamma + \delta = \pi$   
 (c)  $\alpha + \beta = 3\pi$  (d)  $\alpha - \gamma = \pi$
8. The equation  $(1 - \tan\theta)(1 + \tan\theta) \sec^2 \theta + 2 \tan^2 \theta = 0$ ,  $\theta \in \left(-\frac{\pi}{2}, \frac{\pi}{2}\right)$  has solutions  $\theta_1, \theta_2, \dots, \theta_n$ . Then which of the following may be correct?
- (a)  $n = 2$  (b)  $n = 4$   
 (c)  $\sum_{i=1}^n \theta_i = 0$  (d)  $\prod_{i=1}^n \theta_i = -\frac{\pi^2}{9}$
9. The inequation  $2\sin^2\left(x - \frac{\pi}{3}\right) - 5\sin\left(x - \frac{\pi}{3}\right) + 2 > 0$  is satisfied in:
- (a)  $\left(\frac{-5\pi}{6}, \frac{5\pi}{6}\right)$  (b)  $\left(-\frac{2\pi}{3}, \frac{\pi}{2}\right)$   
 (c)  $\left(\frac{\pi}{6}, \frac{5\pi}{6}\right)$  (d)  $\left(\frac{2\pi}{3}(3n-1), \frac{1}{2}(4n+1)\pi\right)$
10. The equation  $\sin^6 x + \cos^6 x = \lambda^2$  has real solution, then  $\lambda$  may belong to the interval
- (a)  $\left[-1, -\frac{1}{2}\right]$  (b)  $(-1, 1)$   
 (c)  $\left[\frac{1}{2}, 1\right]$  (d)  $\left[-\frac{1}{2}, \frac{1}{2}\right]$
11. The equation  $\sin x = [1 - \sin x] + [1 - \cos x]$  has its solutions in interval
- (a)  $(0, \pi)$  (b)  $\left[\frac{\pi}{6}, \frac{2\pi}{3}\right]$   
 (c)  $\left[\frac{\pi}{3}, \frac{5\pi}{6}\right]$  (d)  $\left(\frac{\pi}{2}, \pi\right)$
12. The equation  $\sin^2 x + \sin x - a = 0$ ;  $x \in [0, 2\pi)$  has
- (a) Solutions for every  $a \geq -\frac{1}{4}$   
 (b) two solutions for  $a = -\frac{1}{4}$   
 (c) four solutions for  $-\frac{1}{4} < a < 0$   
 (d) two solutions for  $-\frac{1}{4} < a < 0$
13. For a given value of  $K$  the number of different solutions of the equation  $3 \cos \theta + 4 \sin \theta = K$  in the range  $0^\circ \leq \theta \leq 360^\circ$  is
- (a) zero if  $|K| > 5$  (b) two if  $|K| < 5$   
 (c) One if  $|K| = 5$  (d) no solution for any  $K$



14.  $\sin x - \cos^2 x - 1$  assumes the least value for the set of values of  $x$  given by: (where  $n \in \mathbb{Z}$ )

- (a)  $n\pi + (-1)^{n+1} \frac{\pi}{6}$  (b)  $+(-1) -$   
 (c)  $n\pi + (-1)^n \frac{\pi}{3}$  (d)  $n\pi - (-1)^n \frac{\pi}{6}$

15. If  $\sin(x - y) = \cos(x + y) = 1/2$ , then the values of  $x$  and  $y$  lying between 0 and  $\pi$  are

- (a)  $x = \frac{\pi}{4}, y = \frac{3\pi}{4}$  (b)  $x = \frac{\pi}{4}, y = \frac{\pi}{12}$   
 (c)  $x = \frac{11\pi}{12}, y = \frac{\pi}{12}$  (d)  $x = \frac{11\pi}{12}, y = \frac{3\pi}{4}$

16. The general solution of the equation;  $\cos x \cdot \cos 6x = -1$  is

- (a)  $x = (2n + 1)\pi$  (b)  $x = 2n\pi$   
 (c)  $x = (2n - 1)\pi$  (d) None of these

17. If  $\cos A = \cos B$  and  $\sin A = \sin B$ , then

- (a)  $A + B = 0$  (b)  $A = B$   
 (c)  $A + B = 2n\pi$  (d)  $A - B = 2n\pi$

18. The most general values of  $x$  for which  $\sin x + \cos x = \min_{a \in \mathbb{R}} \{1, a^2 - 4a + 6\}$  are

- (a)  $2n\pi$  (b)  $2n\pi + \frac{\pi}{2}$   
 (c)  $n\pi + (-1)^n \frac{\pi}{4}$  (d) None of these

## SECTION-V

### ASSERTION AND REASON TYPE QUESTIONS

The questions given below consist of an assertion (A) and the reason (R). Use the following key to choose the appropriate answer.

- (a) If both assertion and reason are correct and reason is the correct explanation of the assertion.  
 (b) If both assertion and reason are correct but reason is not correct explanation of the assertion.  
 (c) If assertion is correct, but reason is incorrect  
 (d) If assertion is incorrect, but reason is correct

1. **A:** The most general solution of  $x$  and  $y$  if  $2 \sin x + \cos y = 2$ , is given by

$$y = 2n_1\pi \pm \cos^{-1} 2(1-t) \quad \left. \vphantom{y} \right\} \forall t \in \left[ \frac{1}{2}, 1 \right]$$

$$\text{and } x = n_2\pi + (-1)^{n_2} \sin^{-1}(t)$$

**R:**  $2 \sin x + \cos y = 2 \Rightarrow \cos y = 2(1 - \sin x)$  we have  $\cos y \in [-1, 1]$

$$\Rightarrow -\frac{1}{2} \leq 1 - \sin x \leq \frac{1}{2}$$

$$\Rightarrow \frac{1}{2} \leq \sin x \leq \frac{3}{2} \Rightarrow \frac{1}{2} \leq \sin x \leq 1$$

2. **A:** The domain of the function  $f(x) = \frac{1}{\sqrt{\{\sin x\} + \{\sin(\pi + x)\}}}$  where  $\{\cdot\}$  denotes fractional part, is  $x \neq (2n + 1)\pi/2$ .

**R:**  $\{\sin x\} + \{-\sin x\} = \begin{cases} 0, & \sin x \text{ is integer} \\ 1, & \sin x \text{ is not integer} \end{cases}$

3. **A:** The equation  $\sin x = [1 + \sin x] + [1 - \cos x]$  has no solution for  $x \in \mathbb{R}$  (where  $[\cdot]$  represents greatest integer function)

**R:**  $x - 1 < [x] = x$  for  $x \in \mathbb{R}$

4. **A:** If  $\alpha, \beta$  are the solutions of  $\sin x = -1/2$  in  $[0, 2\pi]$  and  $\alpha, \gamma$  are the solutions of  $\cos x = -\frac{\sqrt{3}}{2}$  in  $[0, 2\pi]$ , then  $\beta - \gamma = \pi$  and  $\alpha + \beta = 3\pi$ .

**R:**  $\sin x$  is positive in quadrant 2 and  $\cos x$  is positive in quadrant 4.

5. **A:** If  $\alpha, \beta$  are the solution of  $\sin x = -1/2$  in  $[0, 2\pi]$  and  $\alpha, \gamma$  are the solutions of  $\tan x = \frac{1}{\sqrt{3}}$  in  $[0, 2\pi]$ , then  $2\alpha = 2\beta + 3\gamma$ .

**R:**  $\sin x$  is positive in Quadrant I and II,  $\tan x$  is positive in Quadrants I and III only.

6. **A:**  $|\sin x| + |\cos x| = 1/2$  has no real solution

**R:**  $|\sin x| + |\cos x| \leq \sqrt{2}$  for all  $x \in \mathbb{R}$

7. **A:** The most general solution of the equation

$$2^{\sin x} + 2^{\cos x} = 2^{1 + \frac{1}{\sqrt{2}}} \text{ is } n\pi + \frac{\pi}{4}$$

**R:** AM of two positive number  $\geq$  GM.

8. **A:** Solution set of the equation  $\cos^2 \left( \frac{px}{2} \right) + \cos^2 \left( \frac{qx}{2} \right) = 1$  consists of two A.P's whose common difference are  $\frac{2\pi}{p+q}$  and  $\frac{2\pi}{p-q}$ .

**R:**  $\cos \theta + \cos \phi = 2 \Rightarrow \cos \theta = \cos \phi = 1$

9. **A:** General solution of the equation

$$\cot\left(\frac{\pi}{3}\cos 2\pi x\right) = \sqrt{3} \text{ is } x = n \pm \frac{1}{6}, n \in \mathbb{Z}.$$

**R:**  $-1 \leq \cos x \leq 1$ .

10. **A:** The number of solution of the equation  $\sin^3 x + \cos^7 x = 1$  in the interval  $[0, 2\pi]$  is 3.

**R:**  $\cos^n x \leq \cos^2 x$  and  $\sin^n x \leq \sin^2 x$  for all  $n \geq 2, n \in \mathbb{N}$

11. **A:** If  $\sin x + \cos x = \sqrt{\left(y + \frac{1}{y}\right)}, x \in [0, \pi],$  then  $x = \frac{\pi}{4}, y = 1$ .

**R:**  $AM \geq GM$

12. **A:** If  $\tan\left(\frac{\pi}{2}\sin\theta\right) = \cot\left(\frac{\pi}{2}\cos\theta\right),$  then  $\sin\theta + \cos\theta = \sqrt{2}$ .

**R:**  $-\sqrt{2} \leq \sin\theta + \cos\theta \leq \sqrt{2}$ .

## SECTION-VI

### MATCH THE COLUMNS TYPE QUESTIONS

This section contains 2 questions. Each question contains statements given in two columns which have to be matched. Statements (i, ii, iii, iv) in **column A** have to be matched with statements (a, b, c, d) in **column B**. The answers to these questions have to be appropriately bubbled as illustrated in the following example. If the correct matches are i-a,d, ii-b,c, iii-a,b, iv-d, then the correctly bubbled  $4 \times 4$  matrix should be as follows:

	a	b	c	d
i	<input checked="" type="radio"/>	<input type="radio"/>	<input type="radio"/>	<input checked="" type="radio"/>
ii	<input type="radio"/>	<input checked="" type="radio"/>	<input checked="" type="radio"/>	<input type="radio"/>
iii	<input checked="" type="radio"/>	<input checked="" type="radio"/>	<input type="radio"/>	<input type="radio"/>
iv	<input type="radio"/>	<input type="radio"/>	<input type="radio"/>	<input checked="" type="radio"/>

#### 1. Column-I

I. If  $(1 - \tan \theta)(1 + \tan \theta) \sec^2 \theta + 2 \tan^2 \theta = 0,$  then in  $\left(0, \frac{\pi}{2}\right), \theta$  is greater than

II. If  $\sum_{n=0}^{\infty} \sin^n \theta = 4 + 2\sqrt{3}; 0 < \theta < \pi, \theta \neq \frac{\pi}{2},$  then  $\theta$  is

III. The value of  $x$  between  $0$  and  $2\pi$  which satisfy the equation  $\sin x \sqrt{8\cos^2 x} = 1$  are in A.P. whose common difference is

IV. If  $2^{\cos 2x} + 1 = 3 \cdot 2^{-\sin^2 x},$  then  $x$  is equal to

#### Column-II

(a)  $\frac{\pi}{4}$

(b)  $\frac{\pi}{2}$

(c)  $\frac{\pi}{3}$

(d)  $\frac{2\pi}{3}$

#### 2. Column-I

I. Number of solutions of the equation  $e^x + e^{-x} = \tan x$   
 $\forall x \in \left[0, \frac{\pi}{2}\right)$

II. Number of solutions of the equations  $x + y = \frac{2\pi}{3}$   
 and  $\cos x + \cos y = \frac{3}{2}$  is

III. Number of solutions of the equation  $\cos x + 2 \sin x = 1, x \in (0, 2\pi]$  is

IV. Number of solutions of the equation

$$\left(\sqrt{3} \sin x + \cos x\right)^{\sqrt{\sqrt{3} \sin 2x - \cos 2x + 2}} = 4 \text{ is}$$

#### Column-II

(a) zero

(b) one

(c) two

(d) infinite

2.70 > Trigonometry

3. Column-I

- I.  $2 \sin^2 x + \sin^2 2x = 2$ , then  $x$  is/are.  
 II.  $|\cos x|^{\sin^2 x - \frac{3}{2} \sin x + \frac{1}{2}} = 1$ , then  $x$  is/are  
 III.  $|\tan x| = \sin 2x$ , then  $x$  is/are  
 IV.  $\cot x + \tan x = 2 \operatorname{cosec} x$ , then  $x$  is/are

Column-II

- (a)  $\frac{\pi}{4}$   
 (b)  $\frac{3\pi}{4}$   
 (c)  $\pi$   
 (d)  $-\frac{\pi}{3} a$

SECTION-VII

COMPREHENSION TYPE QUESTIONS

Passage 1

Consider the equation  $\frac{4}{\sin x} + \frac{1}{1 - \sin x} = a$  where  $x$  is real variable and  $a$  is a real parameter.

Answer the following questions:

- All the values of  $x$  for which the equation is defined are
  - $x \neq n\pi, x \neq (2n + 1)\pi/2$
  - $x \neq n\pi, x \neq (4n + 1)\pi/2$
  - $x \neq n\pi, x \neq (4n - 1)\pi/2$
  - None of these
- The least value of  $a$  for which the given equation has a solution in  $(0, \pi/2)$  must be
  - 6
  - 7
  - 8
  - 9
- If  $a = 10$  then the number of solutions  $\in \left(0, \frac{\pi}{2}\right) \cup \left(\frac{\pi}{2}, \pi\right)$  must be
  - one
  - two
  - three
  - four

Passage 2

An equation of the form  $f(\sin x \pm \cos x, \pm \sin x \cos x) = 0$  can be solved by changing variable.

Let  $\sin x \pm \cos x = t$

$$\Rightarrow \sin^2 x + \cos^2 x \pm 2 \sin x \cos x = t^2$$

$$\Rightarrow \pm \sin x \cos x = \left(\frac{t^2 - 1}{2}\right)$$

Hence, reduce the given equation into  $f\left(t, \frac{t^2 - 1}{2}\right) = 0$

4. If  $1 - \sin 2x = \cos x - \sin x$ , then  $x$  is

- $2n\pi, 2n\pi - \frac{\pi}{2}, n \in \mathbb{Z}$
- $2n\pi, n\pi + \frac{\pi}{2}, n \in \mathbb{Z}$
- $2n\pi, n\pi - \frac{\pi}{4}, n \in \mathbb{Z}$
- None of these

5. If  $\sin x + \cos x = 1 + \sin x \cos x$ , then  $x$  is

- $2n\pi, 2n\pi + \frac{\pi}{2}, n \in \mathbb{Z}$
- $2n\pi, n\pi + \frac{\pi}{4}, n \in \mathbb{Z}$
- $2n\pi - \frac{\pi}{2}, n\pi + \frac{\pi}{4}, n \in \mathbb{Z}$
- None of these

6. If  $1 + \sin^3 x + \cos^3 x = \frac{3}{2} \sin 2x$ , then  $x$  is

- $(2n+1)\pi, 2n\pi + \frac{\pi}{4}, n \in \mathbb{Z}$
- $(2n+1)\pi, 2n\pi - \frac{\pi}{2}, n \in \mathbb{Z}$
- $2n\pi + \frac{\pi}{4}, 2n\pi + \frac{\pi}{2}, n \in \mathbb{Z}$
- None of these

7. If  $(\sin x + \cos x) - 2\sqrt{2} \sin x \cos x = 0$ , then  $x$  is

- $2n\pi + \frac{\pi}{4}, n \in \mathbb{Z}$
- $2n\pi - \frac{\pi}{4}, n \in \mathbb{Z}$
- $n\pi + \frac{\pi}{4}, n \in \mathbb{I}$
- $n\pi - (-1)^n \left(\frac{\pi}{6} - \frac{\pi}{4}\right), n \in \mathbb{Z}$

**Passage 3**

Consider the cubic function  $f(x) = 2x^3 - ax^2 - 3x + b$

8. If  $\sin \theta$  is minima and  $\cos \theta$  is maxima of  $f(x)$  for some  $\theta \in [0, \pi]$  then the set to which  $\theta$  belongs

- (a)  $\left[\frac{\pi}{4}, \pi\right]$                       (b)  $\left(0, \frac{3\pi}{4}\right)$   
 (c)  $\left[0, \frac{\pi}{4}\right]$                       (d)  $\left(\frac{\pi}{4}, \frac{3\pi}{4}\right)$

9. For any  $\theta$  obtained in the above question, a equals

- (a)  $\pm 1$   
 (b)  $-2$   
 (c)  $3$   
 (d)  $0$

10. If  $f(x)$  has a point of inflection at  $x = 6 \sin^2 \theta - 8 \sin \theta \cos \theta$ , then

- (a)  $a \in [50, 100]$                       (b)  $[-12, 12]$   
 (c)  $[-48, 12]$                       (d)  $[-12, 48]$

**SECTION-VIII****INTEGER TYPES QUESTIONS**

- Find the total number of solutions of  $16^{\sin^2 x} + 16^{\cos^2 x} = 10$  in  $x \in [0, 3\pi]$ .
- If  $\tan 5A = \tan \theta$  and  $\tan (3A + B) = 1$ , and  $QA = B + \theta - \pi/p$ ,  $n \in \mathbb{Z}$ . Also, it is given that the value of  $\sqrt{P^3 + R \cdot Q^2} = 10$ , then find the value of  $R$ .
- Find the number of solutions of  $\sin x + \sin 2x + \sin 3x = \cos x + \cos 2x + \cos 3x$ ,  $0 \leq x \leq 2\pi$ .
- Find the values of  $\sqrt{p^2 + q^2 - r^2}$  for which  $x = \frac{n\pi}{p} + \frac{\pi}{q} - \left(\frac{\alpha + \beta + \gamma}{r}\right)$  satisfy the equation  $\tan(x + \beta) \tan(x + \gamma) + \tan(x + \gamma) \tan(x + \alpha) + \tan(x + \alpha) \tan(x + \beta) = 1$
- Find the value of 'k' such that  $\sqrt{p^2 + q^2 + kr^2} = 15$ , where  $x = 2n\pi + \tan^{-1} \frac{p}{q}$ ,  $y = r$ , is a solution of the equation  $12 \sin x + 5 \cos x = 2y^2 - 8y + 21$ .
- Find the number of solutions of the equation  $\sin x + 2 \sin 2x = 3 + \sin 3x$ , where  $x \in [0, \pi]$ .
- Find the total number of solutions of  $\sin \{x\} = \cos \{x\}$ , where  $\{.\}$  denotes the fractional part, in  $[0, 2\pi]$ .
- Find the least positive integer value of 'x' satisfying  $(e^x - 2)(\sin x - \cos x)(x - \ln 2) \left(\cos x - \frac{1}{\sqrt{2}}\right) > 0$ .

9. The value of 'k' for which  $x = n + (-1)^n \pi/k$ ,  $y = 2m\pi \pm 2\pi/3$ ,  $\forall n, m \in \mathbb{Z}$  is a solution of  $2^{\sin x + \cos y} = 1$  and  $16^{\sin^2 x + \cos^2 y} = 4$

10. Find the value of  $\sqrt{p^2 + q^2}$  if the solutions of the equation  $\sqrt{(\sin x)^2 + 2^{1/4}} \cos x = 0$  is given by  $(2n\pi + p\pi/q)$ .

11. The general solution of the equation  $\sin^4 x + \cos^4 x + \sin 2x + \alpha = 0$  is given by  $x = \frac{1}{2}n\pi + (-1)^n \beta/2$ ,  $n \in \mathbb{Z}$ , where  $\beta = \sin^{-1} [1 - \sqrt{(k + 2\alpha)}]$ . Then find the values of 'k'.

12. If two values  $\alpha$  and  $\beta$  be such that  $0 \leq \alpha, \beta \leq \pi$  and satisfy the trigonometric equation  $\cos \alpha \cos \beta \cos(\alpha + \beta) = -\frac{1}{8}$ . Then find the number of possible integral values of  $\frac{\alpha}{\beta}$ .

13. Find the total number of ordered pairs  $(x, y)$  satisfying  $|x| + |y| = 4$ ,  $\sin\left(\frac{\pi x^2}{3}\right) = 1$ .

14. Find the number of integral values of  $x$  where  $f(x) = \sqrt{\ln \cos(\sin x)}$  is defined.

15. Find the sum of all the solutions in  $[0, 100]$  for the equation  $\sin \pi x + \cos \pi x = 0$ .

## Answer Keys

---

### SECTION-III

- |         |         |         |         |         |         |         |         |         |         |
|---------|---------|---------|---------|---------|---------|---------|---------|---------|---------|
| 1. (a)  | 2. (a)  | 3. (b)  | 4. (d)  | 5. (a)  | 6. (c)  | 7. (c)  | 8. (d)  | 9. (c)  | 10. (c) |
| 11. (a) | 12. (c) | 13. (c) | 14. (b) | 15. (a) | 16. (d) | 17. (c) | 18. (d) | 19. (d) | 20. (d) |
| 21. (b) | 22. (b) | 23. (c) | 24. (c) | 25. (d) | 26. (a) | 27. (d) | 28. (c) | 29. (b) | 30. (d) |
| 31. (a) | 32. (c) | 33. (c) | 34. (b) | 35. (d) | 36. (c) | 37. (b) | 38. (b) | 39. (a) | 40. (a) |
| 41. (d) | 42. (a) | 43. (d) | 44. (b) | 45. (a) | 46. (b) | 47. (a) | 48. (c) | 49. (c) | 50. (d) |

### SECTION-IV

- |               |                 |                 |              |              |
|---------------|-----------------|-----------------|--------------|--------------|
| 1. (b, c)     | 2. (a, c)       | 3. (a, b, c, d) | 4. (a, b, c) | 5. (a, c, d) |
| 6. (a, b, c)  | 7. (a, b, c, d) | 8. (a, c)       | 9. (b, d)    | 10. (a, c)   |
| 11. (a, b, c) | 12. (b, c)      | 13. (a, b, c)   | 14. (a, d)   | 15. (b, d)   |
| 16. (a, c)    | 17. (b, d)      | 18. (a, b)      |              |              |

### SECTION-V

- |         |         |        |        |        |        |        |        |        |         |
|---------|---------|--------|--------|--------|--------|--------|--------|--------|---------|
| 1. (a)  | 2. (a)  | 3. (c) | 4. (a) | 5. (d) | 6. (d) | 7. (d) | 8. (b) | 9. (a) | 10. (a) |
| 11. (a) | 12. (d) |        |        |        |        |        |        |        |         |

### SECTION-VI

- |                   |               |                   |            |
|-------------------|---------------|-------------------|------------|
| 1. (i) → (a, c)   | (ii) → (c, d) | (iii) → (a)       | (iv) → (b) |
| 2. (i) → (b)      | (ii) → (a)    | (iii) → (c)       | (iv) → (d) |
| 3. (i) → (a), (b) | (ii) → (c)    | (iii) → (a, b, c) | (iv) → (d) |

### SECTION VII

- |        |        |        |        |        |        |           |        |        |         |
|--------|--------|--------|--------|--------|--------|-----------|--------|--------|---------|
| 1. (b) | 2. (d) | 3. (d) | 4. (d) | 5. (a) | 6. (b) | 7. (a, d) | 8. (a) | 9. (d) | 10. (d) |
|--------|--------|--------|--------|--------|--------|-----------|--------|--------|---------|

### SECTION VIII

- |       |       |        |       |          |      |      |      |      |       |
|-------|-------|--------|-------|----------|------|------|------|------|-------|
| 1. 6  | 2. 9. | 3. 6   | 4. 6  | 5. 14    | 6. 0 | 7. 7 | 8. 4 | 9. 6 | 10. 5 |
| 11. 3 | 12. 3 | 13. 12 | 14. 1 | 15. 5025 |      |      |      |      |       |

## HINTS AND SOLUTIONS

### TEXTUAL EXERCISE-1 (SUBJECTIVE)

1. (a)  $\sin \theta = \frac{1}{\sqrt{2}} \Rightarrow \sin \theta = \sin\left(\frac{\pi}{4}\right)$   
 $\Rightarrow \theta = n\pi + (-1)^n \frac{\pi}{4}$
- (b)  $\sin \theta = 1 \Rightarrow \sin \theta = \sin\left(\frac{\pi}{2}\right)$   
 $\Rightarrow \theta = 2n\pi + \frac{\pi}{2}; n \in \mathbb{Z}$
- (c)  $\sin \theta = -1 \Rightarrow \theta = 2n\pi - \frac{\pi}{2}; n \in \mathbb{Z}$
2. (a)  $\sin(9\theta) = \sin \theta$   
 $\Rightarrow \sin(9\theta) - \sin \theta = 0$   
 $\Rightarrow 2\sin(4\theta)\cos(5\theta) = 0$   
 $\Rightarrow \sin(4\theta) = 0$  or  $\cos(5\theta) = 0$   
 $\Rightarrow 4\theta = n\pi$  or  $5\theta = (2m+1)\frac{\pi}{2}$   
 $\Rightarrow \theta = \frac{n\pi}{4}$  or  $\theta = (2m+1)\frac{\pi}{10}; n, m \in \mathbb{Z}$
- (b)  $\sec \theta = -\sqrt{2}$   
 $\Rightarrow \cos \theta = -\frac{1}{\sqrt{2}} \Rightarrow \cos \theta = \cos\left(\frac{3\pi}{4}\right)$   
 $\Rightarrow \theta = 2n\pi \pm \frac{3\pi}{4}; n \in \mathbb{Z}$
3. (a)  $\sin(3\theta) + 5\sin \theta = 0$   
 $\Rightarrow 3\sin \theta - 4\sin^3 \theta + 5\sin \theta = 0$   
 $\Rightarrow 8\sin \theta - 4\sin^3 \theta = 0$   
 $\Rightarrow 4\sin \theta [2 - \sin^2 \theta] = 0$   
 $\Rightarrow \sin \theta = 0$  or  $\sin^2 \theta = 2$ , but  $0 \leq \sin^2 \theta \leq 1$   
 $\Rightarrow \sin \theta = 0$   
 $\Rightarrow \theta = n\pi; n \in \mathbb{Z}$
- (b)  $\sin \theta + \sin(7\theta) = \sin(4\theta)$   
 $\Rightarrow 2\sin(4\theta)\cos(3\theta) - \sin(4\theta) = 0$   
 $\Rightarrow \sin(4\theta)[2\cos(3\theta) - 1] = 0$   
 $\Rightarrow \sin(4\theta) = 0$  or  $\cos(3\theta) = \frac{1}{2}$   
 $\Rightarrow 4\theta = n\pi$  or  $\cos(3\theta) = \cos\left(\frac{\pi}{3}\right)$   
 $\Rightarrow \theta = \frac{x\pi}{4}$  or  $3\theta = 2m\pi \pm \frac{\pi}{3}$   
 $\Rightarrow \theta = \frac{1}{3}\left[2m\pi \pm \frac{\pi}{3}\right]; n, m \in \mathbb{Z}$
- (c)  $\cos \theta - \sin(3\theta) = \cos(2\theta)$   
 $\Rightarrow \cos \theta - \cos(2\theta) = \sin(3\theta)$   
 $\Rightarrow 2\sin\left(\frac{3\theta}{2}\right)\sin\left(\frac{\theta}{2}\right) = 2\sin\left(\frac{3\theta}{2}\right)\cos\left(\frac{3\theta}{2}\right)$

- $$\Rightarrow \sin\left(\frac{3\theta}{2}\right) = 0 \text{ or } \sin\left(\frac{\theta}{2}\right) = \cos\left(\frac{3\theta}{2}\right)$$
- $$\Rightarrow \frac{3\theta}{2} = 0 \text{ or } \cos\left(\frac{3\theta}{2}\right) = \cos\left(\frac{\pi}{2} - \frac{\theta}{2}\right)$$
- $$\Rightarrow \theta = \frac{2n\pi}{3} \Rightarrow \frac{3\theta}{2} = 2m\pi \pm \left(\frac{\pi}{2} - \frac{\theta}{2}\right)$$
- $$\Rightarrow \frac{3\theta}{2} = 2m\pi + \frac{\pi}{2} - \frac{\theta}{2} \text{ or } \frac{3\theta}{2} = 2m\pi - \frac{\pi}{2} + \frac{\theta}{2}$$
- $$\Rightarrow 2\theta = 2m\pi + \frac{\pi}{2} \Rightarrow \theta = \left(m + \frac{1}{4}\right)\pi$$
- $$\text{or } \theta = 2m\pi - \frac{\pi}{2} \Rightarrow \theta = \left(2m - \frac{1}{2}\right)\pi; n, m \in \mathbb{Z}$$
- (d)  $\sin(7\theta) = \sin \theta + \sin(3\theta)$   
 $\Rightarrow \sin(7\theta) - \sin \theta = \sin(3\theta)$   
 $\Rightarrow 2\cos(4\theta)\sin(3\theta) = \sin(3\theta)$   
 $\Rightarrow \sin(3\theta) = 0$  or  $\cos(4\theta) = \frac{1}{2}$   
 $\Rightarrow 3\theta = n\pi$  or  $\cos(4\theta) = \cos(\pi + 3)$   
 $\Rightarrow \theta = n\pi$  or  $4\theta = 2m\pi \pm \frac{\pi}{3}$   
 $\Rightarrow \theta = n\pi$  or  $\theta = \left(2m \pm \frac{1}{3}\right) \cdot \frac{\pi}{4}; n, m \in \mathbb{Z}$
4. (a)  $\sin\left(\frac{n+1}{2}\theta\right) = \sin\left(\frac{n-1}{2}\theta\right) + \sin \theta$   
 $\Rightarrow \sin\left(\left(\frac{n+1}{2}\right)\theta\right) - \sin\left(\frac{n-1}{2}\theta\right) = \sin \theta$   
 $\Rightarrow 2\sin\left(\frac{\theta}{2}\right)\cos\left(\frac{n\theta}{2}\right) = 2\sin\left(\frac{\theta}{2}\right)\cos\left(\frac{\theta}{2}\right)$   
 $\Rightarrow \sin\left(\frac{\theta}{2}\right) = 0$  or  $\cos\left(\frac{n\theta}{2}\right) = \cos\left(\frac{\theta}{2}\right)$   
 $\Rightarrow \frac{\theta}{2} = n\pi$  or  $\cos\left(\frac{n\theta}{2}\right) - \cos\left(\frac{\theta}{2}\right) = 0$   
 $\Rightarrow \theta = 2n\pi$  or  $2\sin\left(\frac{n+1}{4}\theta\right)\sin\left(\frac{n-1}{4}\theta\right) = 0$   
 $\Rightarrow \frac{(n\pm 1)\theta}{4} = m\pi \Rightarrow \theta = \frac{4m\pi}{n\pm 1}; n, m \in \mathbb{Z}$
- (b)  $\sin(m\theta) + \sin(n\theta) = 0$   
 $\Rightarrow 2\sin\left(\left(\frac{m+n}{2}\right)\theta\right)\cos\left(\left(\frac{m-n}{2}\right)\theta\right) = 0$   
 $\Rightarrow \sin\left(\frac{m+n}{2}\theta\right) = 0$  or  $\cos\left(\frac{m-n}{2}\theta\right) = 0$   
 $\Rightarrow \left(\frac{m+n}{2}\right)\theta = r\pi, \left(\frac{m-n}{2}\right)\theta = (2s+1)\frac{\pi}{2}$   
 $\Rightarrow \theta = \frac{2r\pi}{m+n}$  or  $\theta = \frac{(2s+1)\pi}{m-n}; r, s \in \mathbb{Z}$

**2.74** ➤ Trigonometry

$$\begin{aligned}
 5. \quad & \sin \theta + \sin (3\theta) + \sin (5\theta) = 0 \\
 & \Rightarrow \sin (5\theta) + \sin \theta + \sin (3\theta) = 0 \\
 & \Rightarrow 2 \sin (3\theta) \cos (2\theta) + \sin (3\theta) = 0 \\
 & \Rightarrow \sin (3\theta) [2 \cos (2\theta) + 1] = 0 \\
 & \Rightarrow \sin (3\theta) = 0 \text{ or } \cos (2\theta) = -\frac{1}{2} \\
 & \Rightarrow 3\theta = n\pi \text{ or } \cos (2\theta) = \cos \left( \frac{2\pi}{3} \right) \\
 & \Rightarrow \theta = \frac{n\pi}{3} \text{ or } 2\theta = 2m\pi \pm \frac{2\pi}{3} \\
 & \Rightarrow \theta = m\pi \pm \frac{\pi}{3}; \theta = \left( m \pm \frac{1}{3} \right) \pi; n, m \in \mathbb{Z}
 \end{aligned}$$

**TEXTUAL EXERCISE-2 (SUBJECTIVE)**

$$\begin{aligned}
 1. \quad & \text{(a) } \sin ((m+n)\theta) + \sin ((m-n)\theta) = \sin (m\theta) \\
 & \Rightarrow 2 \sin (m\theta) \cos (n\theta) = \sin (m\theta) \\
 & \Rightarrow \sin (m\theta) = 0 \text{ or } \cos (n\theta) = \frac{1}{2} \\
 & \Rightarrow m\theta = k\pi, k \in \mathbb{Z} \text{ or } n\theta = 2\ell\pi \pm \frac{\pi}{3}, \ell \in \mathbb{Z} \\
 & \Rightarrow \theta = \frac{2\ell\pi}{n} \pm \frac{\pi}{3n} \\
 & \text{(b) } \cos (3\theta) = \cos^3 \theta \\
 & \Rightarrow 4 \cos^3 \theta - 3 \cos \theta = \cos^3 \theta \\
 & \Rightarrow 3 \cos^3 \theta - 3 \cos \theta = 0 \\
 & \Rightarrow 3 \cos \theta [\cos^2 \theta - 1] = 0 \\
 & \Rightarrow \theta = \text{odd multiple of } \frac{\pi}{2} [\because \cos \theta = 0] \text{ or } \cos^2 \theta = 1 \\
 & \Rightarrow \cos \theta = \pm 1 \\
 & \Rightarrow \cos \theta = k\pi, k \in \mathbb{Z} \\
 & \therefore \text{By combining all values we may write } \theta = \frac{\pi}{2}, n \in \mathbb{Z}
 \end{aligned}$$

$$\begin{aligned}
 2. \quad & \text{(a) } \cos \theta + \cos (7\theta) = \cos (4\theta) \\
 & \Rightarrow 2 \cos (4\theta) \cos (3\theta) = \cos (4\theta) \\
 & \Rightarrow \cos (4\theta) = 0 \text{ or } \cos (3\theta) = \frac{1}{2} \\
 & \Rightarrow 4\theta = (2n+1) \cdot \frac{\pi}{2} \Rightarrow \theta = \left( n + \frac{1}{2} \right) \frac{\pi}{4} \\
 & \text{or } \cos (3\theta) = \cos \left( \frac{\pi}{3} \right) \Rightarrow 3\theta = 2n\pi \pm \frac{\pi}{3} \\
 & \Rightarrow \theta = \left( 2n \pm \frac{1}{3} \right) \frac{\pi}{3}; n \in \mathbb{Z}
 \end{aligned}$$

$$\begin{aligned}
 & \text{(b) } \cos \theta + \cos (3\theta) = 2 \cos (2\theta) \\
 & \Rightarrow 2 \cos (2\theta) \cos \theta = 2 \cos (2\theta) \\
 & \Rightarrow \cos (2\theta) = 0 \text{ or } \cos \theta = 1 \\
 & \Rightarrow 2\theta = \frac{(2n+1) \cdot \pi}{2} \text{ or } \theta = 2m\pi \\
 & \Rightarrow \theta = \left( n + \frac{1}{2} \right) \cdot \frac{\pi}{2} \text{ or } \theta = 2m\pi, n, m \in \mathbb{Z}
 \end{aligned}$$

$$\begin{aligned}
 3. \quad & \cos \theta + \cos (2\theta) + \cos (3\theta) = 0 \\
 & \Rightarrow [\cos (3\theta) + \cos \theta] + \cos (2\theta) = 0 \\
 & \Rightarrow 2 \cos (2\theta) \cos (\theta) + \cos (2\theta) = 0 \\
 & \Rightarrow \cos (2\theta) \left[ \cos \theta + \frac{1}{2} \right] = 0 \\
 & \Rightarrow \cos 2\theta = 0 \text{ or } \cos \theta = -\frac{1}{2} \\
 & \Rightarrow 2\theta = (2n+1) \cdot \frac{\pi}{2} \\
 & \Rightarrow \theta = \left( n + \frac{1}{2} \right) \cdot \frac{\pi}{2}; n, m, \in \mathbb{Z} \\
 & \text{or } \cos \theta = \cos \left( \frac{2\pi}{3} \right) \Rightarrow \theta = 2m\pi \pm \frac{2\pi}{3}; m \in \mathbb{Z}
 \end{aligned}$$

$$\begin{aligned}
 4. \quad & \cos (3\theta + \alpha) \cos (3\theta - \alpha) + \cos (5\theta + \alpha) \cos (5\theta - \alpha) = \cos (2\alpha) \\
 & \Rightarrow \frac{1}{2} [2 \cos (3\theta + \alpha) \cos (3\theta - \alpha) \\
 & \quad + 2 \cos (5\theta + \alpha) \cos (5\theta - \alpha)] = \cos (2\alpha) \\
 & \Rightarrow \frac{1}{2} [\cos (6\theta) + \cos (2\alpha) + \cos (10\theta) + \cos (2\alpha)] = \cos (2\alpha) \\
 & \Rightarrow \cos (10\theta) + \cos (6\theta) = 0 \\
 & \Rightarrow 2 \cos (8\theta) \cos (2\theta) = 0 \\
 & \Rightarrow \cos (8\theta) = 0 \text{ or } \cos (2\theta) = 0 \\
 & \Rightarrow 8\theta = (2n+1) \cdot \frac{\pi}{2} \text{ or } 2\theta = (2m+1) \frac{\pi}{2}
 \end{aligned}$$

$$\begin{aligned}
 5. \quad & \sin (3\theta + \alpha) \cdot \sin (3\theta - \alpha) + \sin (\alpha + \theta) \sin (\theta - \alpha) = \cos 2\alpha \\
 & \Rightarrow \sin^2 3\theta - \sin^2 \alpha + \sin^2 \theta - \sin^2 \alpha = \cos^2 \alpha \\
 & \Rightarrow \sin^2 3\theta + \sin^2 \theta = \cos 2\alpha + 2 \sin^2 \alpha \\
 & \Rightarrow \sin^2 3\theta + \sin^2 \theta = 1 - 2 \sin^2 \alpha + 2 \sin^2 \alpha \\
 & \Rightarrow \sin^2 3\theta + \sin^2 \theta = 1 \\
 & \Rightarrow \sin^2 3\theta = \cos^2 \theta = \sin^2 \left( \frac{\pi}{2} - \theta \right) \\
 & \Rightarrow 3\theta = n\pi \pm \left( \frac{\pi}{2} - \theta \right) \\
 & 3\theta = n\pi + \frac{\pi}{2} - \theta \text{ or } 3\theta = n\pi - \frac{\pi}{2} + \theta \\
 & \Rightarrow 4\theta = n\pi + \frac{\pi}{2} \text{ or } 2\theta = n\pi - \frac{\pi}{2} \\
 & \Rightarrow \theta = \frac{n\pi}{4} + \frac{\pi}{8} \text{ or } \theta = \frac{n\pi}{2} - \frac{\pi}{4}; n \in \mathbb{Z}
 \end{aligned}$$

**TEXTUAL EXERCISE-3 (SUBJECTIVE)**

$$\begin{aligned}
 1. \quad & \text{(a) } \tan (5\theta) + \cot (2\theta) = 0 \\
 & \Rightarrow \tan (5\theta) = -\cot (2\theta) \Rightarrow \tan (5\theta) = \tan \left( \frac{\pi}{2} + 2\theta \right) \\
 & \Rightarrow \tan (5\theta) = \tan \left( 2\theta + \frac{\pi}{2} \right) \\
 & \Rightarrow 5\theta = n\pi + 2\theta + \frac{\pi}{2} \Rightarrow 3\theta = n\pi + \frac{\pi}{2} \\
 & \Rightarrow \theta = (2n+1) \cdot \frac{\pi}{6}, n \in \mathbb{Z} \quad \dots \dots (i)
 \end{aligned}$$

∴ For  $\cot 2\theta$  to be defined  $(2n + 1) \neq 3k; k \in \mathbb{Z}$ .

$$\Rightarrow n \neq \frac{3k-1}{2}; k \in \mathbb{Z} \quad \dots \text{(ii)}$$

∴ For  $\tan 5\theta$  to be defined  $(2n+1)\frac{5\pi}{6} \neq (2m+1)\frac{\pi}{2}$

$$\Rightarrow (2n + 1) \neq 3k$$

$$\Rightarrow n \neq \frac{3k-1}{2}; n \in \mathbb{Z} \quad \dots \text{(iii)}$$

∴ From (i), (ii) and (iii), we conclude that

$$\theta \in (2n+1)\frac{\pi}{6}; n \in \mathbb{Z} \sim \left\{ \frac{3k-1}{2}, k \in \mathbb{Z} \right\}$$

(b) If  $\frac{\tan(A+B)}{\tan(A-B)} = \frac{k}{1}$

$$\Rightarrow \frac{\sin(2A)}{\sin(2B)} = \frac{k+1}{k-1} \quad \therefore \text{Here } \frac{\tan(\theta+15^\circ)}{\tan(\theta-15^\circ)} = 3$$

$$\Rightarrow \frac{\sin(2\theta)}{\sin(2 \times 15^\circ)} = \frac{4}{2} \Rightarrow \sin(2\theta) = 1$$

$$\Rightarrow 2\theta = 2n\pi + \frac{\pi}{2}$$

$$\Rightarrow \theta = n\pi + \frac{\pi}{4}, n \in \mathbb{Z}$$

2.  $\sin(3x) = \cos x \Rightarrow \cos\left(\frac{\pi}{2} - 3x\right) = \cos x$

$$\Rightarrow \frac{\pi}{2} - 3x = 2n\pi \pm x \Rightarrow -3x \mp x = 2n\pi - \frac{\pi}{2}$$

$$\Rightarrow \begin{cases} 4x = -2n\pi + \frac{\pi}{2} \\ \text{or} \\ -2x = 2n\pi - \frac{\pi}{2} \end{cases} \Rightarrow \begin{cases} x = 2n\pi + \frac{\pi}{8} \\ \text{or} \\ x = n\pi + \frac{\pi}{4} \end{cases}$$

**Aliter:**  $\sin(3x) = \cos x \Rightarrow 3 \sin x - 4 \sin^3 x = \cos x$

Dividing on both side by  $\cos^3 x$ , we get,  $3 \tan x \sin^2 x - 4 \tan^3 x = \sec^2 x$

$$\Rightarrow 3 \tan x [1 + \tan^2 x] - 4 \tan^3 x = 1 + \tan^2 x$$

$$\Rightarrow -\tan^3 x - \tan^2 x + 3 \tan x - 1 = 0$$

$$\Rightarrow \tan^3 x + \tan^2 x - 3 \tan x + 1 = 0$$

$\Rightarrow \tan x = 1$  is a root of this equation.

$$\Rightarrow (\tan x - 1)$$

$$\Rightarrow \tan x = 1 \text{ or } \tan x = -1 \pm \sqrt{2}$$

$$\Rightarrow x = n\pi + \frac{\pi}{4} \text{ or } x = 2n\pi + \frac{\pi}{8}$$

3. (a)  $\cos \theta = 1 + \cot \theta$

$$\Rightarrow \cos \theta = 1 + \frac{\cos \theta}{\sin \theta}$$

$\sin \theta \cos \theta = \sin \theta + \cos \theta$ ; squaring both side, we get  $\sin^2 \theta \cos^2 \theta = 1 + 2 \sin \theta \cos \theta$

$$\Rightarrow \sin^2 \theta \cos^2 \theta - 2 \sin \theta \cos \theta - 1 = 0. \text{ Let } \sin \theta \cos \theta = t$$

$$\Rightarrow t^2 - 2t - 1 = 0$$

$$\Rightarrow t = \frac{2 \pm \sqrt{8}}{2} = 1 \pm \sqrt{2}$$

$$\therefore \sin \theta \cos \theta = 1 \pm \sqrt{2} \Rightarrow \frac{\sin(2\theta)}{2} = (1 \pm \sqrt{2})$$

$$\Rightarrow \sin(2\theta) = 2 \pm 2\sqrt{2}$$

But  $-1 \leq \sin 2\theta < 1 \Rightarrow \sin(2\theta) \neq 2 + 2\sqrt{2}$

$$\Rightarrow \sin(2\theta) = 2 - 2\sqrt{2} = \sin \alpha \text{ (Say)}$$

Then,  $2\theta = n\pi + (-1)^n \alpha; n \in \mathbb{Z}$

$$\Rightarrow \theta = \frac{n\pi + (-1)^n \alpha}{2}; n \in \mathbb{Z}; \sin \alpha = 2 - 2\sqrt{2}$$

(b)  $\cot \theta - \tan \theta = 2 \Rightarrow \frac{1}{\tan \theta} - \tan \theta = 2$

$$\Rightarrow 1 - \tan^2 \theta - 2 \tan \theta = 0$$

$$\Rightarrow \tan^2 \theta + 2 \tan \theta - 1 = 0$$

$$\Rightarrow \tan \theta = \frac{-2 \pm \sqrt{8}}{2} = -1 \pm \sqrt{2}$$

**Aliter:**  $\cot \theta - \tan \theta = 2$

$$\Rightarrow \frac{\cos \theta}{\sin \theta} - \frac{\sin \theta}{\cos \theta} = 2$$

$$\Rightarrow \cos^2 \theta - \sin^2 \theta = 2 \sin \theta \cos \theta$$

$$\Rightarrow \cos(2\theta) = \sin(2\theta)$$

$$\Rightarrow \tan 2\theta = 1$$

$$\therefore 2\theta = n\pi + \frac{\pi}{4}$$

$$\Rightarrow \theta = \left(x + \frac{1}{4}\right) \cdot \frac{\pi}{2}, n \in \mathbb{Z}$$

(c)  $\tan \theta + \sec \theta = \sqrt{3} \Rightarrow \sec \theta = \sqrt{3} - \tan \theta$ .

Squaring both sides, we get,

$$\sec^2 \theta = 3 + \tan^2 \theta - 2\sqrt{3} \tan \theta$$

$$\Rightarrow 1 + \tan^2 \theta = 3 + \tan^2 \theta - 2\sqrt{3} \tan \theta$$

$$\Rightarrow \tan \theta = \sqrt{3} \Rightarrow \theta = n\pi + \frac{\pi}{6}$$

4.  $\tan \theta + \tan 2\theta + \tan(3\theta) = 0$

$$\Rightarrow \tan \theta + \frac{2 \tan \theta}{1 - \tan^2 \theta} + \frac{3 \tan \theta - \tan^3 \theta}{1 - 3 \tan^2 \theta} = 0$$

Let  $\tan \theta = t$

$$\Rightarrow \text{given equation becomes } t + \frac{2t}{1-t^2} + \frac{3t-t^3}{1-3t^2} = 0$$

$$\Rightarrow t \left[ 1 + \frac{2}{1-t^2} + \frac{3-t^2}{1-3t^2} \right] = 0$$

$$\therefore t = 0 \text{ or } 1 + \frac{2}{1-t^2} + \frac{3-t^2}{1-3t^2} = 0$$

$$\therefore (1-t^2)(1-3t^2) + 2[1-3t^2] + (3-t^2)(1-t^2) = 0$$

$$\Rightarrow 1 - 4t^2 + 3t^4 + 2 - 6t^2 + 3 - 4t^2 + t^4 = 0$$

$$\Rightarrow 4t^4 - 14t^2 + 6 = 0$$

$$\Rightarrow 2t^4 - 7t^2 + 3 = 0$$

$$\therefore 2t^4 - 6t^2 - t^2 + 3 = 0$$

$$\Rightarrow 2t^2 [t^2 - 3] - 1[t^2 - 3] = 0$$

$$\Rightarrow t^2 = 3, t^2 = \frac{1}{2}$$



2.76 > Trigonometry

$$\begin{aligned} \therefore \tan^2 \theta &= \tan^2 \left( \frac{\pi}{3} \right) \Rightarrow \theta = n\pi \pm \frac{\pi}{3} \\ \text{(i) } t &= 0 \Rightarrow \tan \theta = 0 \\ &\Rightarrow \theta = n\pi, n \in \mathbb{Z} \\ \text{(ii) } t^2 &= 3 \Rightarrow \theta = n\pi \pm \frac{\pi}{3}; n \in \mathbb{Z} \\ \text{(iii) } t^2 &= \frac{1}{2} \Rightarrow \tan^2 \theta = \frac{1}{2} = \left( \frac{1}{\sqrt{2}} \right)^2 \\ &\Rightarrow \tan \theta = \pm \frac{1}{\sqrt{2}} \Rightarrow \theta = n\pi \pm \tan^{-1} \left( \frac{1}{\sqrt{2}} \right); n \in \mathbb{Z} \end{aligned}$$

**TEXTUAL EXERCISE-4 (SUBJECTIVE)**

- $\tan^2 x + \cot^2 x = 2$ . Using A.M  $\geq$  G.M we know that,  $\tan^2 x + \cot^2 x \geq 2$   
 Equality holds if  $\tan^2 x = \cot^2 x = 1$   
 $\Rightarrow \tan^2 x = 1 \Rightarrow \tan^2 x = \tan^2 \left( \frac{\pi}{4} \right)$   
 $\therefore x = n\pi \pm \frac{\pi}{4}$
- $\tan^2 x = 3 \operatorname{cosec}^2 x - 1$   
 $\Rightarrow \sec^2 x - 1 = 3 \operatorname{cosec}^2 x - 1$   
 $\Rightarrow \sec^2 x = 3 \operatorname{cosec}^2 x \Rightarrow \frac{1}{\cos^2 x} = 3 \cdot \frac{1}{\sin^2 x}$   
 $\Rightarrow \frac{\sin^2 x}{\cos^2 x} = 3 \tan^2 x = \tan^2 \left( \frac{\pi}{3} \right)$   
 $\Rightarrow x = n\pi \pm \frac{\pi}{3}$
- $2 \sin^2 x + \sin^2(2x) = 2$   
 $\Rightarrow 2 \sin^2 x + (2 \sin x \cos x)^2 = 2$   
 $\Rightarrow \sin^2 x + 2 \sin^2 x \cos^2 x = 1$   
 $\Rightarrow \sin^2 x + 2 \sin^2 x [1 - \sin^2 x] = 1$   
 $\Rightarrow \sin^2 x + 2 \sin^2 x - 2 \sin^4 x = 1$   
 $\Rightarrow 2 \sin^4 x - 3 \sin^2 x - 3 = 0$   
 Let  $\sin^2 x = t$ .  $\Rightarrow 2t^2 - 3t + 1 = 0$   
 $\Rightarrow 2t^2 - 2t - t + 1 = 0$   
 $\Rightarrow (2t - 1)(t - 1) = 0 \Rightarrow t = 1, \frac{1}{2}$   
 $\Rightarrow \sin^2 x = 1$  or  $\sin^2 x = \frac{1}{2}$   
 $\Rightarrow x = n\pi \pm \frac{\pi}{2}$  or  $x = n\pi \pm \frac{\pi}{4}$   
 $\Rightarrow x = (2n+1) \cdot \frac{\pi}{2}$  or  $n\pi \pm \frac{\pi}{4}, n \in \mathbb{Z}$
- $2 + 7 \tan^2 \theta = 3.25 (\sec^2 \theta)$   
 $\Rightarrow 2 + 7 \tan^2 \theta = \frac{13}{4} [1 + \tan^2 \theta]$   
 $\Rightarrow 8 + 28 \tan^2 \theta = 13 + 13 \tan^2 \theta$   
 $\Rightarrow 15 \tan^2 \theta = 5 \Rightarrow \tan^2 \theta = \frac{1}{3} = \tan^2 \left( \frac{\pi}{6} \right)$   
 $\therefore \theta = n\pi \pm n \in \mathbb{Z}$

- $\cos(2\theta) = \cos^2 \theta$   
 $\Rightarrow \cos^2 \theta - \sin^2 \theta = \cos^2 \theta$   
 $\Rightarrow \sin^2 \theta = 0$   
 $\Rightarrow \sin \theta = 0$   
 $\Rightarrow \theta = n\pi, n \in \mathbb{Z}$
- $\sin^2 n\theta - \sin^2(n-1)\theta = \sin^2 \theta$   
 $\Rightarrow \sin(n+n-1)\theta \cdot \sin(n-n+1)\theta = \sin^2 \theta$   
 $\Rightarrow \sin(2n-1)\theta \cdot \sin \theta = \sin^2 \theta$   
 $\Rightarrow \sin \theta [\sin(2n-1)\theta - \sin \theta] = 0$   
 $\Rightarrow \sin \theta = 0$  or  $\sin(2n-1)\theta = \sin \theta$   
**Case (i)**  
 For  $\sin \theta = 0$   
 $\Rightarrow \theta = n\pi, m \in \mathbb{Z}$   
**Case (ii)**  
 $\sin(2n-1)\theta = \sin \theta$   
 $\Rightarrow (2n-1)\theta = k\pi + (-1)^k \cdot \theta$   
 $\Rightarrow (2n-1)\theta = 2m\pi + \theta; m \in \mathbb{Z}$  [for  $k = 2m$ ]  
 $\Rightarrow (2n-2)\theta = 2m\pi$   
 $\Rightarrow \theta = \frac{m\pi}{(n-1)}; m \in \mathbb{Z}$  and for  $k = (2m+1)$   
 $(2n-1)\theta = (2m+1)\pi - \theta$   
 $\Rightarrow 2n\pi = (2m+1)\pi$   
 $\Rightarrow \theta = \frac{(2m+1)\pi}{2n}$   
 $\therefore \theta = m\pi; m \in \mathbb{Z};$   
 $\theta = \frac{m\pi}{(n-1)}; m \in \mathbb{Z}$  or  $\theta = \frac{(2m+1)\pi}{2n}; m \in \mathbb{Z}$

**TEXTUAL EXERCISE-5 (SUBJECTIVE)**

- $3 \tan^2 \theta - 2 \sin \theta = 0$   
 $\Rightarrow \frac{3 \sin^2 \theta}{\cos^2 \theta} - 2 \sin \theta = 0 \Rightarrow \sin \theta \left[ 3 \frac{\sin \theta}{\cos^2 \theta} - 2 \right] = 0$   
 $\Rightarrow \sin \theta = 0$  or  $\frac{3 \sin \theta}{\cos^2 \theta} = 2$   
 $\Rightarrow \theta = n\pi$  or  $3 \sin \theta = 2 \cos^2 \theta$   
 $\Rightarrow 3 \sin \theta = 2 [1 - \sin^2 \theta]$   
 $\Rightarrow 2 \sin^2 \theta + 3 \sin \theta - 2 = 0$   
 $\Rightarrow \sin \theta = -2$  or  $\sin \theta = \frac{1}{2}$   
 $\Rightarrow \theta = n\pi + (-1)^n \cdot \frac{\pi}{6}$   
 $\Rightarrow \theta = n\pi$  or  $\theta = n\pi + (-1)^n \cdot \frac{\pi}{6}, n \in \mathbb{Z}$
- $\sec \theta + \tan \theta = 3 \Rightarrow \tan \theta = 3 - \sec \theta$   
 Squaring both sides, we get  $\tan^2 \theta = 9 + \sec^2 \theta - 6 \sec \theta$   
 $\Rightarrow \sec^2 \theta - 1 = 9 + \sec^2 \theta - 6 \sec \theta$   
 $\Rightarrow 6 \sec \theta + 8 \Rightarrow \sec \theta = \frac{4}{3}$   
 $\Rightarrow$  Number of solution = 3 in  $\theta \in [0, 3\pi]$

3.  $\cot x - \operatorname{cosec} x = 2 \sin x$   
 $\Rightarrow \frac{\cos x}{\sin x} - \frac{1}{\sin x} = 2 \sin x$   
 $\Rightarrow \cos x - 1 = 2 \sin^2 x$   
 $\Rightarrow \cos x - 1 = 2 [1 - \cos^2 x]$   
 $\Rightarrow 2 \cos^2 x + \cos x - 3 = 0$   
 $\Rightarrow \cos x = 1 \text{ or } -\frac{3}{2}$   
 $\therefore \cos x = 1$   
 $\therefore x = 0, 2\pi$ , but at  $x = 0, 2\pi$ ,  $\cot x$  and  $\operatorname{cosec} x$  are not define  
 $\therefore$  Number of solution = Zero.

4. (i) A :  $\cot \theta = \sin (2\theta)$   
 $\Rightarrow \frac{\cos \theta}{\sin \theta} = 2 \sin \theta \cos \theta$   
 $\Rightarrow \cos \theta \left[ \frac{1}{\sin \theta} - 2 \sin \theta \right] = 0$   
 $\Rightarrow \cos \theta = 0 \text{ or } 2 \sin \theta = \frac{1}{\sin \theta}$   
 $\Rightarrow \cos \theta = 0 \text{ or } \sin^2 \theta = \frac{1}{2}$   
 $\Rightarrow \theta = (2n+1) \cdot \frac{\pi}{2} \text{ or } \theta = n\pi \pm \frac{\pi}{4}$   
 $\therefore$  Assertion is incorrect  
**R:**  $\frac{1}{\tan \theta} = \frac{2 \tan \theta}{1 + \tan^2 \theta} \Rightarrow 1 + \tan^2 \theta = 2 \tan^2 \theta$   
 $\Rightarrow \tan^2 \theta = 1 \Rightarrow \theta = n\pi \pm \frac{\pi}{4}$   
 $\therefore$  Reason is correct  $\therefore$  Option (d)  
 (ii) A:  $\frac{\tan 3x - \tan 2x}{1 + \tan 3x \tan 2x} = 1$   
 $\Rightarrow \tan (3x - 2x) = 1 \Rightarrow \tan x = 1$   
 $\Rightarrow x = n\pi + \frac{\pi}{4}$

But for this value of  $x$ ,  $2x = 2n\pi + \frac{\pi}{2}$

- $\therefore \tan (2x)$  is not defined  
 $\therefore$  no solutions  
 $\therefore$  Assertion is incorrect  
 But Reason is true.  
 $\therefore$  **Ans. (d)**

### TEXTUAL EXERCISE-1 (OBJECTIVE)

1. (b)  $\sin \theta = -\frac{\sqrt{3}}{2} \Rightarrow \theta = n\pi + (-1)^n \cdot \left(-\frac{\pi}{3}\right)$   
 i.e.,  $\theta = \pi + \frac{\pi}{3}, 2\pi - \frac{\pi}{3}, 3\pi + \frac{\pi}{3}, 4\pi - \frac{\pi}{3}$  etc.  
 $\tan = \sqrt{3} \Rightarrow \theta = n\pi + \frac{\pi}{3}$

$$\text{i.e., } \theta = \pi + \frac{\pi}{3}, 2\pi + \frac{\pi}{3}, 3\pi + \frac{\pi}{3}, 4\pi + \frac{\pi}{3},$$

$$\therefore \text{Common solution is } \pi + \frac{\pi}{3}, 3\pi + \frac{\pi}{3}, \dots = \frac{4\pi}{3}, 2\pi + \frac{4\pi}{3}$$

$$\text{Hence } \theta = 2n\pi + \frac{4\pi}{3}$$

2. (b)  $\sin x \cdot \sin(60^\circ - x) \cdot \sin(60^\circ + x) = \frac{1}{8}$   
 $\Rightarrow \frac{1}{4} \sin(3x) = \frac{1}{8} \Rightarrow \sin(3x) = \frac{1}{2} = \sin\left(\frac{\pi}{6}\right)$   
 $\Rightarrow 3x = n\pi + (-1)^n \cdot \frac{\pi}{6} \therefore x = \frac{n\pi}{3} + (-1)^n \cdot \frac{\pi}{18}$

3. (i) (a)  $\sin \alpha, 1, \cos (2\alpha)$  all in G.P.  
 $\Rightarrow 1^2 = \sin \alpha \cos (2\alpha) \Rightarrow 1 = \sin \alpha [1 - 2 \sin^2 \alpha]$   
 $\Rightarrow 2 \sin^3 \alpha - \sin \alpha + 1 = 0$   
 $\Rightarrow \sin \alpha = 1$  in a solution of this equation.  
 $\Rightarrow (\sin \alpha + 1)(2 \sin^2 \alpha - 2 \sin \alpha + 1) = 0$   
 $\Rightarrow D < 0 \therefore$  No real root  
 $\therefore \sin \alpha = -1 = \sin\left(-\frac{\pi}{2}\right)$   
 $\therefore \alpha = n\pi + (-1)^n \cdot \left(-\frac{\pi}{2}\right)$   
 $\therefore \alpha = n\pi + (-1)^{n+1} \cdot \left(\frac{\pi}{2}\right)$

- (ii) (c)  $2 \cos^2 \theta + 3 \sin \theta = 0$   
 $\Rightarrow 2(1 - \sin^2 \theta) + 3 \sin \theta = 0$   
 $\Rightarrow 2 \sin^2 \theta - 3 \sin \theta - 2 = 0$   
 $\Rightarrow \sin \theta = 2 \text{ or } \sin \theta = -\frac{1}{2}$   
 $\Rightarrow$  Impossible  $\therefore \sin \theta = -\frac{1}{2}$   
 $\Rightarrow \sin \theta = \sin\left(-\frac{\pi}{6}\right)$   
 $\Rightarrow \theta = n\pi + (-1)^n \cdot \left(-\frac{\pi}{6}\right)$   
 $\Rightarrow \theta = n\pi + (-1)^{n+1} \cdot \left(\frac{\pi}{6}\right)$

- (iii) (c)  $\frac{1}{6} \sin \alpha, \cos \alpha, \tan \alpha$  are in G.P.

- $\therefore 6 \cos^2 \alpha = \sin \alpha \tan \alpha$   
 $\Rightarrow 6 \cos^3 \alpha = \sin^2 \alpha$   
 $\Rightarrow 6 \cos^3 \alpha = 1 - \cos^2 \alpha$   
 $\Rightarrow 6 \cos^3 \alpha + \cos^2 \alpha - 1 = 0$   
 $\therefore \cos \alpha = \frac{1}{2}$  is a solution of equation  
 $\therefore \left(\cos \alpha - \frac{1}{2}\right) \text{ and } (6 \cos^2 \alpha + 4 \cos \alpha + 2) = 0$   
 $\Rightarrow (6 \cos^2 \alpha + 4 \cos \alpha + 2) = 0$   
 $\Rightarrow D < 0 \Rightarrow$  No real root

2.78 > Trigonometry

$$\Rightarrow \left( \cos \alpha - \frac{1}{2} \right) \Rightarrow \cos \alpha = \frac{1}{2}$$

$$\therefore \alpha = 2n\pi \pm \frac{\pi}{3}$$

(iv) (d)  $\sin^2 \alpha - \cos \alpha = \frac{1}{4}, 0 \leq \alpha \leq 2\pi$

$$\Rightarrow 1 - \cos^2 \alpha - \cos \alpha = \frac{1}{4}$$

$$\Rightarrow 4 - 4 \cos^2 \alpha - 4 \cos \alpha - 1 = 0$$

$$\Rightarrow 4 \cos^2 \alpha + 4 \cos \alpha - 3 = 0$$

$$\therefore \cos \alpha = -\frac{3}{2} \text{ or } \frac{1}{2} \Rightarrow \cos \alpha = \frac{1}{2} = \cos \left( \frac{\pi}{3} \right)$$

$$\therefore \alpha = \frac{\pi}{3}, \left( 2\pi - \frac{\pi}{3} \right) = \frac{5\pi}{3}$$

(v) (b)  $2 \sin^2 \alpha + \sqrt{3} \cos \alpha + 1 = 0$

$$\Rightarrow 2(1 - \cos^2 \alpha) + \sqrt{3} \cos \alpha + 1 = 0$$

$$\Rightarrow 2 \cos^2 \alpha - \sqrt{3} \cos \alpha - 3 = 0$$

$$\Rightarrow \cos \alpha = \sqrt{3} \text{ or } \cos \alpha = -\frac{\sqrt{3}}{2}$$

$$\Rightarrow \cos \alpha = \sqrt{3} \text{ is impossible}$$

$$\therefore \cos \alpha = -\frac{\sqrt{3}}{2} = \cos \left( \frac{5\pi}{6} \right)$$

$$\Rightarrow \alpha = 2n\pi \pm \frac{5\pi}{6}$$

4. (a)  $\tan(2\theta) \tan \theta = 1$

$$\Rightarrow \frac{2 \tan \theta}{1 - \tan^2 \theta} \cdot \tan \theta = 1 \Rightarrow 2 \tan^2 \theta = 1 - \tan^2 \theta$$

$$\Rightarrow 3 \tan^2 \theta = 1 \Rightarrow \tan^2 \theta = \frac{1}{3}$$

$$\Rightarrow \tan^2 \theta = \tan^2 \left( \frac{\pi}{6} \right)$$

$$\Rightarrow \theta = n\pi \pm \frac{\pi}{6}$$

5. (a)  $\tan \theta + \tan 2\theta + \sqrt{3} \tan \theta \tan 2\theta = \sqrt{3}$

$$\Rightarrow \tan 2\theta + \tan \theta = \sqrt{3} [1 - \tan 2\theta \tan \theta]$$

$$\Rightarrow \frac{\tan 2\theta + \tan \theta}{1 - \tan 2\theta \cdot \tan \theta} = \sqrt{3}$$

$$\Rightarrow \tan(3\theta) = \sqrt{3} \Rightarrow \tan(3\theta) = \tan \left( \frac{\pi}{3} \right)$$

$$\Rightarrow 3\theta = n\pi + \frac{\pi}{3} \Rightarrow \theta = \left( n + \frac{1}{3} \right) \cdot \frac{\pi}{3}$$

$$\Rightarrow \theta = (3n + 1) \cdot \frac{\pi}{9}$$

6. (a)  $\sin \theta + \sin 5\theta = \sin(3\theta)$

$$\Rightarrow 2 \sin \left( \frac{\theta + 5\theta}{2} \right) \cos \left( \frac{5\theta - \theta}{2} \right) - \sin(3\theta) = 0$$

$$\Rightarrow \sin(3\theta) [2 \cos(2\theta) - 1] = 0$$

$$\Rightarrow \sin(3\theta) = 0 \text{ or } \cos(2\theta) = \frac{1}{2}$$

$$\Rightarrow \sin(3\theta) = 0 \quad \therefore 3\theta = 0, \pi, 2\pi, 3\pi$$

$$\Rightarrow \theta = 0, \frac{\pi}{3}, \frac{2\pi}{3}, \pi$$

$$\Rightarrow \cos(2\theta) = \frac{1}{2} \Rightarrow 2\theta = \frac{\pi}{3}, \frac{5\pi}{3}$$

$$\Rightarrow \theta = \frac{\pi}{6}, \frac{5\pi}{6}$$

$$[\because 0 \leq \theta \leq \pi \Rightarrow 0 \leq 3\theta \leq 3\pi]$$

$$\therefore 6 \text{ solution } 0 \leq \theta \leq \pi$$

$$\Rightarrow 0 \leq 2\theta \leq 2\pi$$

7. (b)  $\sin \theta + \cos \theta = 1$

$$\Rightarrow \sqrt{2} \left[ \frac{1}{\sqrt{2}} \sin \theta + \frac{1}{\sqrt{2}} \cos \theta \right] = 1$$

$$\Rightarrow \sqrt{2} \left[ \sin \theta \cos \frac{\pi}{4} + \cos \theta \sin \frac{\pi}{4} \right] = 1$$

$$\Rightarrow \sin \left( \theta + \frac{\pi}{4} \right) = \frac{1}{\sqrt{2}}$$

$$\Rightarrow \theta + \frac{\pi}{4} = n\pi + (-1)^n \cdot \frac{\pi}{4}$$

$$\Rightarrow \theta = n\pi + (-1)^n \cdot \frac{\pi}{4} - \frac{\pi}{4}$$

8. (b)  $\cot \theta - \tan \theta = 2$ . Let  $\tan \theta = t$

$$\Rightarrow \frac{1}{t} - t = 2 \Rightarrow 1 - t^2 - 2t = 0$$

$$\Rightarrow t^2 + 2t - 1 = 0 \Rightarrow 2t = 1 - t^2$$

$$\Rightarrow \frac{2t}{1 - t^2} = 1$$

$$\Rightarrow \tan(2\theta) = 1 = \tan \left( \frac{\pi}{4} \right)$$

$$\Rightarrow 2\theta = n\pi + \frac{\pi}{4} \Rightarrow \theta = \frac{n\pi}{2} + \frac{\pi}{8}$$

9. (b)  $\sin^2 \theta - 2 \cos \theta + \frac{1}{4} = 0$

$$\Rightarrow 4 \sin^2 \theta - 8 \cos \theta + 1 = 0$$

$$\Rightarrow 4(1 - \cos^2 \theta) - 8 \cos \theta + 1 = 0$$

$$\Rightarrow 4 \cos^2 \theta + 8 \cos \theta - 5 = 0$$

$$\therefore \cos \theta = -\frac{5}{2} \text{ or } \frac{1}{2}$$

$$\Rightarrow \cos \theta = -\frac{5}{2} \text{ is not possible}$$

$$\Rightarrow \cos \theta = \frac{1}{2} = \cos \left( \frac{\pi}{3} \right) \therefore \theta = 2n\pi \pm \frac{\pi}{3}$$

10. (c)  $2 \tan^2 \theta = \sec^2 \theta$

$$\Rightarrow 2 \tan^2 \theta = 1 + \tan^2 \theta \Rightarrow \tan^2 \theta = 1$$

$$\Rightarrow \tan^2 \theta = \tan^2 \left( \frac{\pi}{4} \right) \Rightarrow \theta = \pi \pm$$

11. (a)  $\sin \theta - \sin \alpha \therefore \theta = n\pi + (-1)^n \alpha$

$$\therefore \theta = \alpha, \pi - \alpha, 2\pi + \alpha, 3\pi - \alpha, 4\pi + \alpha, \dots$$

$$\begin{aligned} \Rightarrow \cos \theta &= \cos \alpha & \Rightarrow \theta &= 2n\pi \pm \alpha \\ \Rightarrow \theta &= \alpha, -\alpha, 2\pi + \alpha, 2\pi - \alpha, 4\pi + \alpha, 4\pi - \alpha, \dots \\ &\text{Common values } \alpha, 2\pi + \alpha, 4\pi + \alpha \text{ i.e., } \theta = 2n\pi + \alpha \end{aligned}$$

12. (b)  $\cos x \cos\left(\frac{\pi}{3} + x\right) \cos\left(\frac{\pi}{3} - x\right) = \frac{1}{4} x \in [0, 6\pi]$

$$\begin{aligned} \Rightarrow \frac{1}{4} \cos(3x) &= \frac{1}{4} & \Rightarrow \cos(3x) &= 1 \\ \therefore 3x &= 2\pi, 4\pi, 6\pi, 8\pi, 10\pi, \dots, 18\pi \\ \therefore \text{sum of all values} &= \frac{2[1+2+\dots+9] \cdot \pi}{3} \\ &= \frac{2 \times 9 \times 10}{2 \times 3} \times \pi = 30\pi \end{aligned}$$

**TEXTUAL EXERCISE-6 (SUBJECTIVE)**

1.  $\cos x = |1 + \sin x| = \begin{cases} 1 + \sin x & \text{for } \sin x \geq -1 \\ -(1 + \sin x) & \text{for } \sin x < -1 \end{cases}$ , but  $\nless -1$

$$\begin{aligned} \Rightarrow \cos x &= 1 + \sin x & \Rightarrow \cos x - \sin x &= 1 \\ \Rightarrow \cos\left(x - \frac{\pi}{4}\right) &= \sqrt{2}; x \in [0, 3\pi] \\ \Rightarrow \left(x - \frac{\pi}{4}\right) &\in \left[\frac{\pi}{4}, 3\pi + \frac{\pi}{4}\right] \text{ in which } \cos\left(x - \frac{\pi}{4}\right) = \frac{1}{\sqrt{2}} \\ &\text{holds for 3 times} \\ \Rightarrow \text{Clearly 3 solutions, } x &= 0, \frac{3\pi}{2}, 2\pi \end{aligned}$$

2.  $(\sin x + \cos x)^{1+\sin(2x)} = 2$

$$\begin{aligned} \therefore -1 &\leq \sin(2x) \leq 1 \\ \Rightarrow 0 &\leq 1 + \sin(2x) \leq 2, \text{ also } -\sqrt{2} \leq \sin x + \cos x \leq \sqrt{2} \\ \therefore \text{Only possibilities is } \sin x + \cos x &= \sqrt{2} \text{ and } 1 + \sin 2x = 2 \\ \Rightarrow \sqrt{2} \left[ \frac{1}{\sqrt{2}} \sin x + \frac{1}{\sqrt{2}} \cos x \right] &= \sqrt{2} \text{ and } \sin(2x) = 1 \\ \Rightarrow \sin\left(x + \frac{\pi}{4}\right) &= 1 \text{ and } \sin(2x) = 1 \\ \Rightarrow \sin\left(x + \frac{\pi}{4}\right) &= 1 & \Rightarrow x + \frac{\pi}{4} &= \frac{\pi}{2} \\ \Rightarrow x &= \frac{\pi}{4} \\ \Rightarrow \sin(2x) &= 1 & \Rightarrow 2x &= \frac{\pi}{2}, -\frac{3\pi}{2} \\ \Rightarrow x &= \frac{\pi}{4}, -\frac{3\pi}{4} \\ \therefore x &= \frac{\pi}{4} \text{ is its common solution} \end{aligned}$$

3.  $(\sqrt{2}-1)\cos\theta + \sin\theta = 1$  .....(i)

$$\begin{aligned} \Rightarrow (\sqrt{2}-1)\cos\theta &= 1 - \sin\theta \\ \Rightarrow \sqrt{2}-1 &= \frac{1 - \sin\theta}{\cos\theta} \end{aligned}$$

$$\begin{aligned} &= \frac{1 - \cos\left(\frac{\pi}{2} - \theta\right)}{\sin\left(\frac{\pi}{2} - \theta\right)} = \frac{2 \sin^2\left(\frac{\pi}{4} - \frac{\theta}{2}\right)}{\sin\left(\frac{\pi}{4} - \frac{\theta}{2}\right) \cdot \cos\left(\frac{\pi}{4} - \frac{\theta}{2}\right)} \\ \Rightarrow (\sqrt{2}-1) &= \tan\left(\frac{\pi}{4} - \frac{\theta}{2}\right) \\ \Rightarrow \tan\left(\frac{\pi}{8}\right) &= \tan\left(\frac{\pi}{4} - \frac{\theta}{2}\right) \\ \Rightarrow \frac{\pi}{8} - \frac{\theta}{2} &= n\pi + \frac{\pi}{8} \\ \Rightarrow \frac{\theta}{2} &= -n\pi + \frac{\pi}{4} - \frac{\pi}{8} = -n\pi + \frac{\pi}{8} \\ \Rightarrow \theta &= 2n\pi + \frac{\pi}{4}; n \in \mathbb{Z} \end{aligned}$$

4.  $2 \cos \theta + 3 \sin \theta = 3$

Dividing by  $\sqrt{4+9} = \sqrt{13}$ , we get

$$\frac{2}{\sqrt{13}} \cos \theta + \frac{3}{\sqrt{13}} \sin \theta = \frac{3}{\sqrt{13}} \quad \dots\dots\dots (i)$$

$$\Rightarrow \cos(\theta - \alpha) = \frac{3}{\sqrt{13}} = \cos\left(\frac{\pi}{2} - \alpha\right)$$

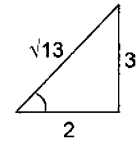

$$\begin{aligned} \Rightarrow \theta - \alpha &= 2n\pi \pm \left(\frac{\pi}{2} - \alpha\right) \\ \Rightarrow \theta &= 2n\pi + \frac{\pi}{2} \text{ or } \theta = 2n\pi - \frac{\pi}{2} + 2\alpha \\ \Rightarrow \theta &= (4n+1)\frac{\pi}{2} \text{ or } \theta = (4n-1)\frac{\pi}{2} + 2\alpha \text{ where} \\ \alpha &= \sin^{-1}\left(\frac{3}{\sqrt{13}}\right) \text{ or } \cos^{-1}\left(\frac{2}{\sqrt{13}}\right) \text{ or } \tan^{-1}\left(\frac{3}{2}\right) \end{aligned}$$

5.  $\sin^2 x + \sin x \cos x = n$

$$\begin{aligned} \Rightarrow \frac{1 - \cos 2x}{2} + \frac{\sin 2x}{2} &= n \\ \Rightarrow 1 - 2n &= \cos 2x - \sin 2x \\ \Rightarrow -\sqrt{2} &\leq 1 - 2n \leq \sqrt{2} \\ \Rightarrow -\sqrt{2} - 1 &\leq -2n \leq \sqrt{2} - 1 \\ \Rightarrow 1 - \sqrt{2} &\leq 2n \leq 1 + \sqrt{2} \\ \Rightarrow \frac{1 - \sqrt{2}}{2} &\leq n \leq \frac{1 + \sqrt{2}}{2} \\ \therefore n &\in \mathbb{Z} \\ \Rightarrow n &= 0, 1 \\ \Rightarrow \text{Two integral values of } n. \end{aligned}$$

**TEXTUAL EXERCISE-7 (SUBJECTIVE)**

1.  $2 \sin^2 x - 5 \sin x \cos x - 8 \cos^2 x = -2$

Dividing by  $\cos^2 x$ , we get,  $2 \tan^2 x - 5 \tan x - 8 = -2 \sec^2 x$

$$\Rightarrow 2 \tan^2 x - 5 \tan x - 8 = -2(1 + \tan^2 x)$$

**2.80** ➤ Trigonometry

$$\Rightarrow 4 \tan^2 x - 5 \tan x - 6 = 0$$

$$\Rightarrow \tan x = -\frac{3}{4} \text{ or } 2$$

$$\therefore x = n\pi + \tan^{-1}(2) \text{ or } x = n\pi + \tan^{-1}\left(-\frac{3}{4}\right)$$

2.  $3 - \cos^2 \theta - 2\sqrt{3} \sin \theta \cos \theta + \sin^2 \theta = 0$

Dividing by  $\cos^2 \theta$ , we get  $3 - 2\sqrt{3} \tan \theta + \tan^2 \theta = 0$

$$\Rightarrow \tan^2 \theta - 2\sqrt{3} \tan \theta + 3 = 0$$

$$\therefore (\tan \theta - \sqrt{3})^2 = 0 \Rightarrow \tan \theta = \sqrt{3}$$

$$\Rightarrow \theta = n\pi + \frac{\pi}{3}$$

3.  $6 \sin^2 \theta - \sin \theta \cos \theta - \cos^2 \theta = 3$

Dividing by  $\cos^2 \theta$ , we get,  $6 \tan^2 \theta - \tan \theta - 1 = 3 \sec^2 \theta$

$$\Rightarrow 6 \tan^2 \theta - \tan \theta - 1 = 3(1 + \tan^2 \theta)$$

$$\Rightarrow 3 \tan^2 \theta - \tan \theta - 4 = 0$$

$$\Rightarrow \tan \theta = -1 \text{ or } \tan \theta = \frac{4}{3}$$

$$\therefore \theta = n\pi - \frac{\pi}{4} \text{ or } \theta = n\pi + \tan^{-1}\left(\frac{4}{3}\right)$$

4.  $x^2 + 2x + 3 = 0$ ;  $D < 0$

⇒ The equation have both root non-real and complex conjugate

∴ Given equation have both root common

$$\frac{2 \sin \theta}{1} = \frac{-4\sqrt{3} \cos \theta}{2} = \frac{3\sqrt{3}}{3}$$

$$\Rightarrow \sin \theta = \frac{\sqrt{3}}{2} \text{ and } \cos \theta = -\frac{1}{2}$$

$$\therefore \theta = 2n\pi + \frac{2\pi}{3}$$

**TEXTUAL EXERCISE-2 (OBJECTIVE)**

1. (c) From Theory

2. (b)  $\cos \theta + \sqrt{3} \sin \theta = 5$

$$a = \sqrt{3}, b = 6, c = 5$$

$$\text{Here } c > \sqrt{a^2 + b^2}$$

∴ No solution

3. (b)  $\sin x + \sqrt{3} \cos x = \sqrt{2}$

Dividing by  $\sqrt{1 + (\sqrt{3})^2}$  i.e., 2

$$\Rightarrow \frac{1}{2} \sin x + \frac{\sqrt{3}}{2} \cos x = \frac{1}{\sqrt{2}}$$

$$\Rightarrow \cos\left(\frac{\pi}{6}\right) \cos x + \sin\left(\frac{\pi}{6}\right) \sin x = \frac{1}{\sqrt{2}}$$

$$\Rightarrow \cos\left(x - \frac{\pi}{6}\right) = \cos\left(\frac{\pi}{4}\right)$$

$$\Rightarrow x - \frac{\pi}{6} = 2n\pi \pm \frac{\pi}{4} \Rightarrow x = 2n\pi \pm \frac{\pi}{4} + \frac{\pi}{6}$$

$$\Rightarrow x = 2n\pi + \frac{5\pi}{12} \text{ or } x = 2n\pi - \frac{\pi}{12}$$

4. (c)  $\sqrt{2} \sec \theta + \tan \theta = 1$

$$\Rightarrow \frac{\sqrt{2}}{\cos \theta} + \frac{\sin \theta}{\cos \theta} = 1$$

$$\Rightarrow \sin \theta - \cos \theta = -\sqrt{2}$$

Dividing by  $\sqrt{2}$ , we get,  $\frac{1}{\sqrt{2}} \sin \theta - \frac{1}{\sqrt{2}} \cos \theta = -1$

$$\Rightarrow \sin\left(\frac{\pi}{4}\right) \sin \theta - \cos\left(\frac{\pi}{4}\right) \cos \theta = -1$$

$$\Rightarrow \cos\left(\frac{\pi}{4}\right) \cos \theta - \sin \theta \sin\left(\frac{\pi}{4}\right) = 1$$

$$\Rightarrow \cos\left(\frac{\pi}{4} + \theta\right) = 1 \Rightarrow \theta + \frac{\pi}{4} = 2n\pi$$

$$\Rightarrow \theta = 2n\pi - \frac{\pi}{4}$$

5. (b)  $\tan \theta + \sec \theta = \sqrt{3}$ ; (i),  $0 < \theta < 2\pi$

$$(\sec^2 \theta - \tan^2 \theta) = 1$$

$$\Rightarrow (\sec \theta - \tan \theta)(\sec \theta + \tan \theta) = 1$$

$$\Rightarrow \sec \theta - \tan \theta = 1/\sqrt{3} \quad \dots \text{(ii)}$$

Solving (i) & (ii), we get  $2 \sec \theta = \sqrt{3} + \frac{1}{\sqrt{3}} = \frac{4}{\sqrt{3}}$

$$\Rightarrow \sec \theta = \frac{2}{\sqrt{3}} \Rightarrow \cos \theta = \frac{\sqrt{3}}{2}$$

Also  $\tan \theta = \sqrt{3} - \sec \theta = \sqrt{3} - \frac{2}{\sqrt{3}} = \frac{1}{\sqrt{3}}$

$$\therefore \cos \theta = \sqrt{3}/2; \tan \theta = 1/\sqrt{3} \text{ and } \theta \in (0, 2\pi)$$

⇒  $\theta = \pi/6$ , i.e., there is only one solution

6. (b)  $3 \cos \theta + 4 \sin \theta = k$

For solution  $|k| \leq \sqrt{3^2 + 4^2}$

$$\Rightarrow |k| \leq 5$$

But  $|k| = 5$

∴ Given equation becomes  $3 \cos \theta + 4 \sin \theta \pm 5$

Dividing by 5, we get  $\frac{3}{5} \cos \theta + \frac{4}{5} \sin \theta = \pm 1 \quad \dots \dots \text{(i)}$

After replacing  $\frac{3}{5} = r \cos \alpha$  and  $\frac{4}{5} = r \sin \alpha$ , we get

equation into the form  $\cos(\theta + \alpha) = \pm 1$

∴ Only 2 solution is possible.

7. (c)  $\tan x + \sec x = 2 \cos x$ ;  $x \in [0, 2\pi]$

$$\Rightarrow \frac{\sin x}{\cos x} + \frac{1}{\cos x} = 2 \cos x; (\cos x \neq 0)$$

$$\Rightarrow \sin x + 1 = 2 \cos^2 x$$

$$\Rightarrow \sin x + 1 = 2(1 - \sin^2 x)$$

$$\Rightarrow 2 \sin^2 x + \sin x - 1 = 0$$

$$\therefore \sin x = -1$$

or  $\sin x = \frac{1}{2}$ ; But when  $\sin x = -1$

then  $x = \frac{3\pi}{2}$  and  $\cos\left(\frac{3\pi}{2}\right) = 0$

$$\therefore \sin x \neq -1 \quad \therefore \sin x = \frac{1}{2}$$

∴ 2 solutions

8. (b)  $k \cos x - 3 \sin x = k + 1$   
 For a solution  $|k+1| \leq \sqrt{k^2+9}$   
 Squaring both sides, we get  $k^2+1+2k \leq k^2+9$   
 $\Rightarrow 2k \leq 8 \Rightarrow k \leq 4$   
 $\Rightarrow k \in (-\infty, 4)$
9. (a, c)  $\sin^4 x + \cos^4 x + \sin(2x) + a = 0$   
 $\Rightarrow (\sin^2 x + \cos^2 x) - 2\sin^2 x \cos^2 x + \sin(2x) + a = 0$   
 $\Rightarrow 1 - \frac{\sin^2(2x)}{2} + \sin(2x) + a = 0$   
 $\Rightarrow 2 - t^2 + 2t + 2a = 0$ ; where  $t = \sin(2x)$   
 $\Rightarrow t^2 - 2t - 2(a+1) = 0$   
 $\Rightarrow (t-1)^2 - 1 - 2(a+1) = 0$   
 $\Rightarrow (t-1)^2 = 1 + 2(a+1)$  ..... (i)  
 Now  $-1 \leq \sin(2x) \leq 1$   
 $\Rightarrow -1 \leq t \leq 1$   
 $\Rightarrow -2 \leq t-1 \leq 0$   
 $\Rightarrow 0 \leq (t-1)^2 \leq 4$   
 $\Rightarrow$  From equation (i), we get  $0 \leq 1 + 2(a+1) \leq 4$   
 $\Rightarrow -\frac{1}{2} \leq a+1 \leq \frac{3}{2} \Rightarrow -\frac{3}{2} \leq a \leq \frac{1}{2}$
10. (b)  $|x| < 1$   
 $\Rightarrow x \in (-1, 1) \Rightarrow 3x \in (-3, 3)$   
 $\Rightarrow \sin 3x \in [-1, 1]$   
 $\Rightarrow$  Let  $\sin x = t \in (-1, 1)$   
 $\Rightarrow 3t - 4t^3 \in [-1, 1]$   
 $\Rightarrow 3t - 4t^3 \leq 1$   
 i.e.,  $3x - 4x^3 \leq 1 \forall x \in (-1, 1)$   
 $\Rightarrow 3x - 4x^3 \leq 1 \forall |x| < 1$
11. (c)  $3\sin x + 4\cos ax = 7$  has atleast one solution  
 $\Rightarrow \sin x = 1$  and  $\cos ax = 1$   
 $\Rightarrow x = (4n+1)\pi/2$  &  $ax = 2k\pi$   
 $\Rightarrow x = (4n+1)\pi/2 = 2k\pi/a$   
 $\Rightarrow a = \frac{4k}{2n+1}$   
 $\Rightarrow a$  must be a rational numbers
12. (d)  $a_1 + a_2 \cos(2x) + a_3 \sin^2 x = 1$   
 $\Rightarrow a_1 + a_2 \frac{[1-2\sin^2 x]}{2} + a_3 \sin^2 x = 1$   
 $\Rightarrow 2a_1 + a_2 + \sin^2 x [a_3 - 2a_2] - 2 = 0$   
 $\Rightarrow (a_3 - 2a_2) \sin^2 x + (2a_1 + a_2 - 2) = 0$   
 $\therefore a_3 = 2a_2$  and  $2a_1 + a_2 = 2$   
 $\therefore$  Infinite solution
13. (c)  $\cos^4 x + a \cos^2 x + 1 = 0$   
 If  $a > 0$   
 Then L.H.S.  $> 0$ , R.H.S.  $= 0$   
 $\therefore$  Not possible  
 If  $a = 0$ ,  $\cos^4 x + 1 = 0$  is not possible  
 $\therefore$  'a' must be negative  
 Now given equation is  $\cos^4 x + a \cos^2 x + 1 = 0$   
 $\Rightarrow t^2 + at + 1 = 0$ , where  $t = \cos^2 x$ . Which is a quadratic in t.

- $\therefore$  For atleast one solution  $D \geq 0$   
 $\Rightarrow a^2 - 4 \geq 0 \Rightarrow a^2 \geq 4$   
 $\Rightarrow |a| \geq 2 \Rightarrow a \leq -2$   
 or  $a \geq 2$   
 $\therefore a \in (-\infty, -2)$
14. (b)  $\sin \theta + \sqrt{3} \cos \theta = 6x - x^2 - 11$   
 For  $6x - x^2 - 11$   
 Maximum value is  $-\frac{[D]}{4a} = -\frac{[36-44]}{4 \times -1} = -2$   
 Also range of a  $\sin x + b \cos x$  is  $[-\sqrt{a^2+b^2}, \sqrt{a^2+b^2}]$   
 $\therefore$  Range of  $\sin \theta + \sqrt{3} \cos \theta$  is  $[-2, 2]$   
 $\therefore$  Only inequality holds  $\therefore \sin \theta + \sqrt{3} \cos \theta = -2$   
 Dividing by 2, we get  $\frac{1}{2} \sin \theta + \frac{\sqrt{3}}{2} \cos \theta = -1$   
 $\Rightarrow \sin \theta \cos\left(\frac{\pi}{3}\right) + \cos \theta \sin\left(\frac{\pi}{3}\right) = -1$   
 $\therefore \sin\left(\theta + \frac{\pi}{3}\right) = -1 \therefore \theta + \frac{\pi}{3} = \frac{3\pi}{2}, \frac{7\pi}{2}$   
 $\therefore$  2 value of 'θ' and one value of  $x = 3$
15. (a)  $\sin x + \cos x - 2\sqrt{2} \sin x \cos x = 0$   
 $\Rightarrow \sin x + \cos x = \sqrt{2} \sin(2x)$   
 Dividing by  $\sqrt{2}$ , we get  
 $\frac{1}{\sqrt{2}} \sin x + \frac{1}{\sqrt{2}} \cos x = \frac{\sqrt{2}}{\sqrt{2}} \sin(2x)$   
 $\Rightarrow \sin\left(x + \frac{\pi}{4}\right) = \sin(2x)$   
 $\Rightarrow x + \frac{\pi}{4} = n\pi + (-1)^n \cdot (2x)$   
 $\Rightarrow x - (-1)^n \cdot 2x = n\pi - \frac{\pi}{4}$   
 Case 1: when n is odd  
 $3x = (2k+1) \cdot \pi - \frac{\pi}{4} = (8k+3) \frac{\pi}{4}$   
 $\Rightarrow x = (8k+3) \cdot \frac{\pi}{12}$   
 Case 2: when n is even  
 $-x = 2k\pi - \frac{\pi}{4} \Rightarrow x = -2k\pi + \frac{\pi}{4}$

16. (b)
- 
- TEXTUAL EXERCISE-8 (SUBJECTIVE)**
1.  $7 \cos^2 \theta + 3 \sin^2 \theta = 4$   
 $\Rightarrow 7(1 - \sin^2 \theta) + 3 \sin^2 \theta = 4$   
 $\Rightarrow 3 = 4 \sin^2 \theta$   
 $\Rightarrow \sin^2 \theta = \frac{3}{4} = \sin^2\left(\frac{\pi}{3}\right)$   
 $\Rightarrow \theta = n\pi \pm \frac{\pi}{3}$

**2.82** ➤ Trigonometry

2.  $\sin^4 x + \cos^4 x = \sin x \cos x$   
 $\Rightarrow (\sin^2 x + \cos^2 x)^2 - 2 \sin^2 x \cos^2 x = \sin x \cos x$   
 $\Rightarrow 1 - \frac{\sin^2(2x)}{2} = \frac{\sin(2x)}{2}$   
 Let  $\sin(2x) = t$   
 $\therefore$  Given equation becomes  $2 - t^2 = t$   
 $\Rightarrow t^2 + t - 2 = 0$   
 $\Rightarrow (t+2)(t-1) = 0 \quad \therefore t = -2 \text{ or } 1$   
 $\Rightarrow \sin(2x) = -2$  is impossible  
 $\therefore \sin(2x) = 1 \quad \therefore 2x = (4n+1) \times \frac{\pi}{2}$   
 $\Rightarrow x = (4n+1) \cdot \frac{\pi}{4}, n \in \mathbb{Z}$

3.  $\sec x + \operatorname{cosec} x = 2\sqrt{2}$   
 $\Rightarrow \frac{1}{\cos x} + \frac{1}{\sin x} = 2\sqrt{2}$   
 $\Rightarrow \sin x + \cos x = 2\sqrt{2} \sin x \cos x$   
 $\Rightarrow \sin x \cdot \frac{1}{\sqrt{2}} + \cos x \cdot \frac{1}{\sqrt{2}} = \sin 2x$   
 $\Rightarrow \sin\left(x + \frac{\pi}{4}\right) = \sin 2x$   
 $\Rightarrow x + \frac{\pi}{4} = n\pi + (-1)^n(2x)$

$\Rightarrow x - (-1)^n(2x) = n\pi - \frac{\pi}{4}$   
 $\Rightarrow x(1 - 2(-1)^n) = n\pi - \frac{\pi}{4}$

For  $n = \text{odd}$

$\Rightarrow x(3) = (2m+1)\pi - \frac{\pi}{4}$   
 $\Rightarrow x = (2m+1)\frac{\pi}{3} - \frac{\pi}{12}$

For  $n = \text{even}$

$\Rightarrow x = (1-2) = 2m\pi - \frac{\pi}{4}$   
 $\Rightarrow x = 2m\pi + \frac{\pi}{4}$

4.  $\sin^2 x - \sin x + \cos x = 1$   
 $\Rightarrow \cos x - \sin x = \cos^2 x$   
 $\Rightarrow (\cos x)(1 - \cos x) = \sin x$   
 $\Rightarrow 1 - \cos x = \tan x$   
 $\Rightarrow 2\sin^2 \frac{x}{2} = \frac{\sin x}{\cos x}$   
 $\Rightarrow 2\sin^2 \frac{x}{2} = \frac{2\sin \frac{x}{2} \cos \frac{x}{2}}{\cos x}$   
 $\Rightarrow 2\sin^2 \frac{x}{2} \cos x - 2\sin \frac{x}{2} \cos \frac{x}{2} = 0$   
 $\Rightarrow 2\sin \frac{x}{2} \left[ \sin \frac{x}{2} \cos x - \cos \frac{x}{2} \right] = 0$   
 $\Rightarrow \frac{x}{2} = n\pi \text{ or } \sin \frac{x}{2} \cos x - \cos \frac{x}{2} = 0$

$\Rightarrow \frac{x}{2} = n\pi \text{ or } \cos x = \cot \frac{x}{2}; \frac{1 - \tan^2 x/2}{1 + \tan^2 x/2} = \frac{1}{\tan x/2}$

$\Rightarrow t - t^3 = 1 + t^2$  where  $t = \tan x/2$

$\Rightarrow t^3 + t^2 - t + 1 = 0$

Let  $f(t) = t^3 + t^2 - t + 1$

$f'(t) = 3t^2 + 2t - 1$

$\therefore f'(t) = 0 \Rightarrow (3t-1)(t+1) = 0$

$\Rightarrow t = -1 \text{ or } t = 1/3$

$\Rightarrow$  Graph of  $y = f(t)$  will be as

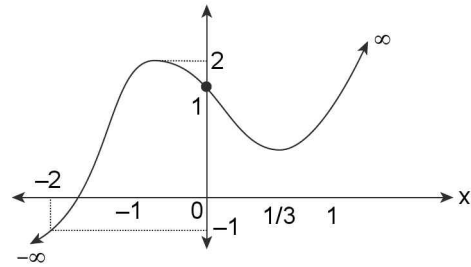

Clearly  $f(t) = 0$  has only one root in  $t \in [-2, 1] = t_0$  say then

$\tan \frac{x}{2} = t_0 \in [-2, -1]$

$\therefore$  For  $x \in [-4\pi, 4\pi]$ , i.e.,  $\frac{x}{2} \in [-2\pi, 2\pi]$

$\tan \frac{\pi}{2} = t_0$  will be attained 4 times i.e.,  $\frac{x}{2} \in \left(-\frac{3\pi}{2}, -\pi\right); \left(-\frac{\pi}{2}, 0\right); \left(\frac{\pi}{2}, \pi\right)$  and  $\left(\frac{3\pi}{2}, 2\pi\right)$

Also  $\frac{x}{2} = n\pi$

$\Rightarrow x = 2n\pi; n \in \mathbb{Z}$

$\therefore$  For  $x \in [-4\pi, 4\pi]$   $x$  will attain the values  $x = -4\pi, -2\pi, 0, 2\pi$  and  $4\pi$  i.e., 5 values

$\therefore$  Total  $(4 + 5)$  i.e., 9 solution

5.  $\sin^4 x + \cos^4 x = 1$   
 $\Rightarrow (\sin^2 x + \cos^2 x)^2 - 2 \sin^2 x \cos^2 x = 1$   
 $\Rightarrow 1 - 2 \sin^2 x \cos^2 x = 1$   
 $\Rightarrow 2 \sin^2 x \cos^2 x = 0$   
 $\Rightarrow \frac{\sin^2(2x)}{2} = 0$   
 $\Rightarrow \sin(2x) = 0$   
 $\Rightarrow 2x = n\pi$   
 $\Rightarrow x = \frac{n\pi}{2}, n \in \mathbb{Z}$

6.  $\sin^2 x - 5 \sin x \cos x - 6 \cos^2 x = 0$   
 $\Rightarrow \tan^2 x - 5 \tan x - 6 = 0$   
 $\Rightarrow (\tan x - 6)(\tan x + 1) = 0$   
 $\Rightarrow \tan x = 6 \text{ or } \tan x = -1$   
 $\Rightarrow x = n\pi + \tan^{-1}(6) \text{ or } x = n\pi - \frac{\pi}{4}$

**TEXTUAL EXERCISE-9 (SUBJECTIVE)**

1.  $\sin\theta = 1/\sqrt{2}$ ;  $\cot\theta = -1$   
 $\Rightarrow \theta$  lies in II<sup>nd</sup> quadrant  
 $\Rightarrow \theta = (2n + 1)\pi - \pi/4$   
 $\Rightarrow \theta = 2n\pi + \frac{3\pi}{4}$   
 $\Rightarrow \theta = (8n + 3)\frac{\pi}{4}; n \in \mathbb{Z}$  is the general solution

2.  $\sin\theta = -\frac{\sqrt{3}}{2} \Rightarrow \theta = n\pi + (-1)^n \times \left(-\frac{\pi}{3}\right)$   
 $\Rightarrow \theta = \frac{4\pi}{3}, \frac{10\pi}{3}, \dots$   
 $\tan\theta = \sqrt{3}$   
 $\Rightarrow \theta = n\pi + \frac{\pi}{3} \Rightarrow \theta = \frac{\pi}{3}, \frac{4\pi}{3}, \frac{7\pi}{3}, \frac{10\pi}{3}, \dots$   
 $\therefore$  Common solution  $\theta = 2n\pi + \frac{4\pi}{3}$

3.  $\cos\theta = \frac{1}{\sqrt{2}} \Rightarrow \theta = \pm\frac{\pi}{4}$   
 $\Rightarrow 2\pi \pm \frac{\pi}{4}$   
 $\tan\theta = -1 \Rightarrow \theta = -\frac{\pi}{4}, \frac{3\pi}{4}, \dots$   
 $\Rightarrow \theta = n\pi - \frac{\pi}{4}$   
 $\Rightarrow$  Common solution  $\theta = 2n\pi \pm \frac{\pi}{4}$

4.  $\sin\theta = -\frac{1}{2} \Rightarrow \theta = n\pi + (-1)^n \times \left(-\frac{\pi}{6}\right)$   
 $\Rightarrow \theta = -\frac{\pi}{6}, \frac{7\pi}{6}, \frac{11\pi}{6}, \frac{19\pi}{6}, \dots$   
 $\tan\theta = \frac{1}{\sqrt{3}} \Rightarrow \theta = n\pi + \frac{\pi}{6}$   
 $\Rightarrow \theta = \frac{\pi}{6}, \frac{7\pi}{6}, \frac{19\pi}{6}, \dots$   
 $\therefore$  Common solution is  $\theta = 2n\pi + \frac{7\pi}{6}$

5. (i)  $\sin(x + y) = 0 \dots (i)$   
 and  $\sin(x - y) = 0 \dots (ii)$   
 From (i) and (ii), we get  
 $x + y = n\pi, n \in \mathbb{Z}$   
 $x - y = m\pi$   
 Adding and sub subtracting, we get  
 $x = (n + m)\frac{\pi}{2}, y = (n - m)\frac{\pi}{2}$   
 (ii)  $x + y = \frac{\pi}{3}, \sin x \sin y = \frac{1}{4}$   
 $\Rightarrow \sin x \sin\left(\frac{\pi}{3} - x\right) = \frac{1}{4}$

$$\Rightarrow \sin x \left[ \sin\left(\frac{\pi}{3}\right)\cos x - \cos\frac{\pi}{3}\sin x \right] = \frac{1}{4}$$

$$\Rightarrow \sin x \left[ \frac{\sqrt{3}}{2}\cos x - \frac{1}{2}\sin x \right] = \frac{1}{4}$$

$$\Rightarrow \frac{\sqrt{3}}{2}\sin x \cos x - \frac{\sin^2 x}{2} = \frac{1}{4}$$

$$\Rightarrow 2\sqrt{3}\sin x \cos x - 2\sin^2 x - 1 = 0$$

$$\Rightarrow 2\sin^2 x - 2\sqrt{3}\sin x \cos x + 1 = 0$$

Dividing by  $\cos^2 x$ , we get,  
 $2\tan^2 x - 2\sqrt{3}\tan x + \sec^2 x = 0$   
 $\Rightarrow 2\tan^2 x - 2\sqrt{3}\tan x + 1 + \tan^2 x = 0$   
 $\Rightarrow 3\tan^2 x - 2\sqrt{3}\tan x + 1 = 0$   
 $\Rightarrow (\sqrt{3}\tan x - 1)^2 = 0$   
 $\Rightarrow \tan x = \frac{1}{\sqrt{3}} \therefore x = n\pi + \frac{\pi}{6}$   
 From  $x + y = \frac{\pi}{3}$ , we get  $y = -n\pi + \frac{\pi}{6}$

6.  $\frac{1 - \tan x}{1 + \tan x} = \tan y \dots (i)$

$x - y = \frac{\pi}{6} \dots (ii)$

From (i), we get  $\tan\left(\frac{\pi}{4} - x\right) = \tan y$

$\Rightarrow \frac{\pi}{4} - x = n\pi + y$

$\Rightarrow x + y = \frac{\pi}{4} - n\pi \dots (iii)$

From (ii) and (iii), we get  $2x = \frac{5\pi}{12} - n\pi$

$\Rightarrow x = \frac{5\pi}{24} - \frac{n\pi}{2}$

Also  $x - y = \frac{\pi}{6}$

$\therefore y = x - \frac{\pi}{6} = \frac{5\pi}{24} - \frac{n\pi}{2} - \frac{\pi}{6} = \frac{\pi}{24} - \frac{n\pi}{2}$

**TEXTUAL EXERCISE-10 (SUBJECTIVE)**

1.  $\cos(x - y) = \frac{1}{2} \dots (i)$

$\sin(x + y) = \frac{1}{2} \dots (iii)$

$x - y = 2n\pi \pm \frac{\pi}{3} \dots (iii)$

and  $x + y = m\pi + (-1)^m \cdot \frac{\pi}{6} \dots (iv)$

From (iii) and (iv) we get,  $2x = 2n\pi + m\pi + (-1)^m \cdot \frac{\pi}{6} \pm \frac{\pi}{3}$



**2.84** ➤ Trigonometry

$$\therefore x = (2n + m) \cdot \frac{\pi}{2} \pm \frac{\pi}{6} + (-1)^m \cdot \frac{\pi}{12}$$

Also  $2y = m\pi - 2n\pi + (-1)^m \cdot \frac{\pi}{6} \mp \frac{\pi}{3}$

$$\Rightarrow y = (m - 2n)\pi + (-1)^m \cdot \frac{\pi}{12} \mp \frac{\pi}{6}$$

$\therefore$  Smallest value of  $x$  and  $y$  are obtained when  $x - y = \frac{\pi}{3}$

and  $x + y = \frac{5\pi}{6}$

$$\therefore y = \frac{\pi}{4} \text{ and } x = \frac{\pi}{3} + \frac{\pi}{4} = \frac{7\pi}{12}$$

$$\Rightarrow x = \frac{7\pi}{12}, y = \frac{\pi}{4}$$

**2.**  $3 \sin^2 A + 2 \sin^2 B = 1$  ..... (i)

$3 \sin(2A) - 2 \sin(2B) = 0$  ..... (ii)

$$\Rightarrow 3 \sin^2 A = \cos 2B \quad \Rightarrow \quad \frac{3}{2}(1 - \cos 2A) = \cos 2B$$

$$\Rightarrow 3 - 3 \cos 2A = 2 \cos 2B$$

$$\Rightarrow 3 \cos 2A + 2 \cos 2B = 3 \text{ and } 3 \sin 2A - 2 \sin 2B = 0$$

$$\Rightarrow 9 \sin^2 2A = 4 \sin^2 2B$$

$$\Rightarrow \sin^2 2A = \frac{4}{9} \sin^2 2B$$

$$\Rightarrow 1 - \cos^2 2A = \frac{4}{9}(1 - \cos^2 2B)$$

$$\Rightarrow 1 - \cos^2 2A = \frac{4}{9} \left[ 1 - \left( \frac{3 - 3 \cos^2 A}{2} \right)^2 \right]$$

$$\Rightarrow 9 - 9 \cos^2 2A = 4 - (3 - 3 \cos 2A)^2$$

$$\Rightarrow 9 - 9 \cos^2 2A = 4 - 9 - 9 \cos^2 2A + 18 \cos 2A$$

$$\Rightarrow 14 = 18 \cos 2A \quad \Rightarrow \quad \cos 2A = \frac{7}{9}$$

$$\Rightarrow \cos 2B = \frac{1}{3}$$

$$\Rightarrow \sin^2 A = \frac{1}{9} \quad \Rightarrow \quad \sin A = \frac{1}{3} \quad (\because A \text{ is acute})$$

$$\therefore \cos 2B = \sin A = \cos \left( \frac{\pi}{2} - A \right)$$

$$\Rightarrow 2B + A = \frac{\pi}{2}$$

**3.**  $x + y = \frac{\pi}{4}$  ..... (i)

and  $\tan x + \tan y = 1$  ..... (ii)

From (i), we get,  $\tan(x + y) = \tan \left( \frac{\pi}{4} \right)$

$$\Rightarrow \frac{\tan x + \tan y}{1 - \tan x \tan y} = 1$$

$$\Rightarrow \frac{1}{1 - \tan x \tan y} = 1 \text{ [using (ii)]}$$

$$\Rightarrow \tan x \tan y = 0 \text{ ..... (iii)}$$

From (ii) and (iii), we get,  $A + B = 1, AB = 0$ .

Where  $A = \tan x; B = \tan y$

$$\therefore A = 0 \text{ or } B = 0$$

$$\therefore x = n\pi, y = \frac{\pi}{4} - n\pi \text{ or } y = n\pi, x = \frac{\pi}{4} - n\pi, x \in \mathbb{Z}$$

**4.**  $\sin(x + y) = 0$  ..... (i)

$\sin(x - y) = 0$  ..... (ii)

$\Rightarrow x + y = n\pi$  ..... (iii)

$\Rightarrow x - y = m\pi$  ..... (iv)

$$\therefore x = (n + m) \cdot \frac{\pi}{2} \text{ and } y = (n - m) \cdot \frac{\pi}{2}$$

**5.**  $\sin x + \sin y = \sqrt{2}$

$$\Rightarrow \sin \left( \frac{x + y}{2} \right) \cos \left( \frac{x - y}{2} \right) = \frac{1}{\sqrt{2}} \text{ .....(i)}$$

And  $\cos x \cos y = 1/2$

$$\Rightarrow \cos(x + y) + \cos(x - y) = 1 \text{ .....(ii)}$$

Let  $\sin \left( \frac{x + y}{2} \right) = a$  &  $\cos \left( \frac{x - y}{2} \right) = b$ .

Thus we get  $ab = \frac{1}{\sqrt{2}}$  &  $1 - 2a^2 + 2b^2 - 1 = 1$

$$\Rightarrow \begin{cases} ab = \frac{1}{\sqrt{2}} \\ b^2 - a^2 = \frac{1}{2} \end{cases}$$

$$\Rightarrow b^2 + a^2 = \sqrt{\frac{1}{4} + 4 \left( \frac{1}{2} \right)} = \frac{3}{2}$$

$$\Rightarrow 2b^2 = 2 \text{ & } 2a^2 = 1$$

$\Rightarrow b^2 = 1$  &  $a^2 = 1/2$  thus the equation reduces to

$$\Rightarrow \sin^2 \left( \frac{x + y}{2} \right) = \left( \frac{1}{\sqrt{2}} \right)^2 \text{ ... (iii)}$$

$$\Rightarrow \frac{x + y}{2} = n\pi \pm \frac{\pi}{4}$$

$$\Rightarrow \cos^2 \left( \frac{x - y}{2} \right) = 1 \text{ ... (iv)}$$

$$\Rightarrow \frac{x - y}{2} = m\pi$$

$$\Rightarrow x + y = 2n\pi \pm \pi/2 \text{ & } x - y = 2m\pi$$

Thus  $\begin{cases} x = (m + n)\pi \pm \frac{\pi}{4} \\ y = (n - m)\pi \pm \frac{\pi}{4} \end{cases}$

**TEXTUAL EXERCISE-3 (OBJECTIVE)**

**1. (c)**  $\cos x + \cos y = 2$  ..... (i)

$-1 \leq \cos x \leq 1$  and  $-1 \leq \cos y \leq 1$

$\therefore$  Equation (i) is true only if both  $\cos x + \cos y$  are 1

$\therefore \cos x = 1, \cos y = 1$

$\therefore x = y = 0$   
 $\therefore \cos(x - y) = \cos 0 = 1$

2. (b)  $\sin^2 x - \sin x - 1 = 0$   
 $\Rightarrow \sin x = \frac{1 \pm \sqrt{5}}{2}$

But  $\sin x \leq 1 \Rightarrow \sin x \neq \frac{1 + \sqrt{5}}{2}$

$\therefore \sin x = \frac{1 - \sqrt{5}}{2}$

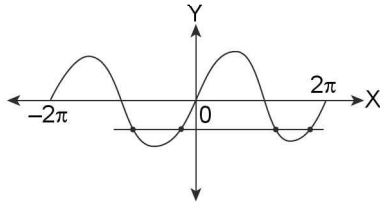

$\therefore$  4 solutions

3. (a)  $\cos x \cdot \sin y = 1$ . Since  $-1 \leq \cos x \leq 1; -1 \leq \sin y \leq 1$   
 $\therefore \cos x \cdot \sin y = 1$  is only possible if  
 $\cos x = \sin y = 1$  ..... (i)  
 and  $\cos x = \sin y = -1$  ..... (ii)

For (i), we get,  $x = 0, 2\pi, y = \frac{\pi}{2}, \frac{5\pi}{2}$

$\therefore$  4 ordered from of (x, y)

For (ii), we get,  $x = \pi, 3\pi, \quad \text{---}$

$\therefore$  2 ordered pairs  
 $\therefore$  Total 6 ordered pairs

4. (b) As in previous question no. (3)  
 Ordered pair is  $x = 0, 2\pi, y = \frac{\pi}{2}$  or  $x = \pi, y = \frac{3\pi}{2}$

$\therefore$  3 ordered pair

5. (c)  $1 - 2x - x^2 = \tan^2(x + y) + \cot^2(x + y)$   
 Maximum value of L.H.S. = 4  
 $\therefore$  for a quadratic maximum value is  $-\frac{D}{4a}$ , if coeffi-

cient of  $x^2 < 0$  and  $\tan^2(x + y) + \cot^2(x + y) \geq 2$   
 [A.M.  $\geq$  G.M.]

$\Rightarrow$  Only equality holds.  
 $\therefore 1 - 2x - x^2 = 2$   
 $\Rightarrow x^2 + 2x + 1 = 0$   
 $\Rightarrow x = -1$   
 $\therefore \tan^2(x + y) = 1$   
 $\Rightarrow \tan^2(y - 1) = 1$   
 $\Rightarrow y - 1 = n\pi \pm \frac{\pi}{4}$   
 $\Rightarrow y - 1 = \pm \frac{\pi}{4}, \frac{3\pi}{4}, \frac{5\pi}{4}, \frac{7\pi}{4}, \dots$   
 $\Rightarrow y = (2n + 1)\frac{\pi}{4} + 1$

6. (a)  $\frac{1 - \tan x}{1 + \tan x} = \tan y$   
 $\Rightarrow \tan\left(\frac{\pi}{4} - x\right) = \tan y \Rightarrow y = n\pi + \frac{\pi}{4} - x$   
 $\Rightarrow x + y = n\pi + \frac{\pi}{4}$  ..... (i)

$\Rightarrow x - y = \frac{\pi}{6}$  ..... (ii)

Adding (i) and (ii), we get  $2x = n\pi + \frac{5\pi}{12}$

$\therefore x = \frac{n\pi}{2} + \frac{5\pi}{24}$

Also  $x - y = \frac{\pi}{6}$  ..... (iii) (given)

$\therefore y = x - \frac{\pi}{6} = \frac{n\pi}{2} + \frac{\pi}{24}$

7. (c)  $4 + \sin^2 x + \cos^2 x = 5 \sin^2 x \sin^2 y$   
 $\Rightarrow 5 = 5 \sin^2 x \sin^2 y \Rightarrow (\sin x \sin y)^2 = 1$   
 $\Rightarrow \sin^2 x \sin^2 y = 1 \Rightarrow \sin^2 x = \sin^2 y = 1$   
 $\Rightarrow (x, y) \in \left\{ \left( n\pi + \frac{\pi}{2}, m\pi + \frac{\pi}{2} \right); n, m \in \mathbb{Z} \right\}$

8. (a, b)  $\sin^2 x = \sin y$  ..... (i)  
 $\cos^4 x = \cos y$  ..... (ii)

$\Rightarrow \sin^4 x + \cos^8 x$   
 $\Rightarrow \cos^8 x = (1 - \sin^2 x)(1 + \sin^2 x) = (\cos^2 x)(1 + \sin^2 x)$   
 $\Rightarrow (\cos^2 x)(\cos^6 x - 1 - \sin^2 x) = 0$   
 $\Rightarrow (\cos^2 x)[\cos^6 x - 1 - (1 - \cos^2 x)] = 0$   
 $\Rightarrow (\cos^2 x)[\cos^6 x + \cos^2 x - 2] = 0$   
 $\Rightarrow \cos x = 0 \Rightarrow x = (2n + 1)\frac{\pi}{2}$  .....(i)

Let  $\cos^2 x = t$   
 $\Rightarrow t^3 + t - 2 = 0$ ; clearly  $t = 1$  is a root.  
 $\therefore t^2 + t + 2 = 0$  for which roots are imaginary  
 $\therefore \cos^2 x = 1 \Rightarrow \cos x = \pm 1$   
 $\Rightarrow x = n\pi; n \in \mathbb{Z}$  .....(ii)

Clearly from (i) and (ii), we get  $x = \text{--- } n \in \mathbb{Z}$

$\Rightarrow \sin y = \begin{cases} 1 & \text{for } n = \text{odd} \\ 0 & \text{for } n = \text{even} \end{cases}$   
 and  $\cos y = \begin{cases} 0 & \text{for } n = \text{odd} \\ 1 & \text{for } n = \text{even} \end{cases}$   
 $\Rightarrow y = \begin{cases} \left( 2n\pi + \frac{\pi}{2} \right) & \text{for } n = \text{odd} \\ 2m\pi & \text{for } n = \text{even} \end{cases}$

$\therefore$  Complete solution will be  
 $(x, y) = y = \begin{cases} x = (2n + 1)\frac{\pi}{2}; & y = 2m\pi + \frac{\pi}{2} \\ x = n\pi; & y = 2m\pi \end{cases}$

**2.86** ➤ Trigonometry

9. (b, c)  $\sin^2 x + \sin^2 y = \frac{3}{4}$   
 $\Rightarrow \frac{1 - \cos(2x)}{2} + \left(\frac{1 - \cos(2y)}{2}\right) = \frac{3}{4}$   
 $\Rightarrow \frac{1}{4} = \frac{1}{2}[\cos(2x) + \cos(2y)]$   
 $\Rightarrow \cos(2x) + \cos(2y) = \frac{1}{2}$   
 $\Rightarrow 2\cos(x+y)\cos(x-y) = \frac{1}{2}$   
 $\cos(x+y)\cos(x-y) = \frac{1}{4}$  ..... (i)  
 Also  $x+y = \frac{\pi}{3}$  (given) ..... (ii)  
 $\therefore$  From (i) and (ii), we get  $\cos\left(\frac{\pi}{3}\right)\cos(x-y) = \frac{1}{4}$   
 $\Rightarrow \cos(x-y) = \frac{1}{2}$   
 $\therefore x-y = 2n\pi \pm \frac{\pi}{3}$  ..... (iii)  
 $\therefore$  (ii) and (iii), gives  $2x = 2n\pi \pm \frac{\pi}{3} + \frac{\pi}{3}$   
 $\Rightarrow 2x = 2n\pi$  or  $2n\pi + \frac{2\pi}{3}$   
 $\therefore x = n\pi$  or  $n\pi + \frac{\pi}{3}$   
 $\therefore y = \frac{\pi}{3} - n\pi$  or  $n\pi$

**TEXTUAL EXERCISE-11 (SUBJECTIVE)**

1.  $\sin^6 x = 1 + \cos^4(3x)$   
 $\therefore 0 \leq \sin^6 x \leq 1$  and  $1 \leq 1 + \cos^4(3x) \leq 2$   
 $\therefore$  Only equality holds  
 $\therefore \sin^6 x = 1$  and  $\cos^4(3x) = 0$   
 $\therefore x = (2n+1) \cdot \frac{\pi}{2}, n \in \mathbb{Z}$

2.  $2\cos^2\left(\frac{x^2+x}{6}\right) = 2^x + 2^{-x}$   
 $\therefore 2\cos^2\left(\frac{x^2+x}{6}\right) \leq 2$  and  $2^x + 2^{-x} \geq 2$   
 $\therefore$  Only equality holds.  
 $\therefore 2^x = 1$   
 $\Rightarrow x = 0$  and  $\cos^2\left(\frac{x^2+x}{6}\right) = 1$   
 $\Rightarrow x = 0$   
 $\therefore x = 0$  is the only solution

3.  $\sin^2 x + \cos^2 y + \sin^2 z = 3 \operatorname{cosec}^2 u$   
 $\therefore 0 \leq \sin^2 x \leq 1$        $\therefore 0 \leq \cos^2 y \leq 1$   
 $\therefore 0 \leq \sin^2 z \leq 1$        $\therefore \text{L.H.S.} \leq 3$   
 Also  $\operatorname{cosec}^2 u \geq 1$        $\Rightarrow \text{R.H.S.} \geq 3$   
 $\therefore$  only equality holds  
 $\therefore \sin^2 x = \cos^2 y = \sin^2 z = \operatorname{cosec}^2 u = 1$   
 $\Rightarrow x = (2m+1) \cdot \frac{\pi}{2}; y = n\pi,$   
 $z = (2p+1) \cdot \frac{\pi}{2}; u = (2q+1) \times \frac{\pi}{2},$  where  $m, n, p, q \in \mathbb{Z}$ .

4.  $\cos^6(2x) = 1 + \sin^4 x$   
 $\therefore 0 \leq \cos^6(2x) \leq 1$  and  $1 \leq 1 + \sin^4 x \leq 2$   
 $\therefore$  Only equality holds  
 $\therefore \cos^6(2x) = 1$  and  $\sin^4 x = 0$   
 $\therefore 2x = 2n\pi$  and  $x = m\pi$   
 $\therefore x = n\pi, x = m\pi$   
 $\therefore x = k\pi, k \in \mathbb{Z}$

**TEXTUAL EXERCISE-4 (OBJECTIVE)**

1. (d)  $\sin x \cos x = 2$   
 $\Rightarrow 2 \sin x \cos x = 4$        $\Rightarrow \sin(2x) = 4$   
 But  $-1 \leq \sin(2x) \leq 1$   
 $\therefore$  Given equation has no solution.

2. (a)  $2 \cos(e^x) = 5^x + 5^{-x}$   
 We know that  $-1 \leq \cos(e^x) \leq 1$   
 $\Rightarrow -2 \leq 2 \cos(e^x) \leq 2$   
 $\therefore \text{L.H.S.} \in [-2, 2]$   
 Also  $5^x + 5^{-x} \geq 2$   
 $\therefore$  Only equality holds  
 $\therefore 2 \cos(e^x) = 2$   
 $\Rightarrow \cos(e^x) = 1$   
 $\therefore e^x = 0$  which is not possible  
 $\therefore$  No solution

3. (b) As in above question only equality holds.  
 $\Rightarrow \cos(2n\pi x) = 1$   
 $\therefore 2n\pi x = 0$   
 $\therefore x = 0$   
 Also for  $x = 0$  R.H.S. = 2  
 $\therefore x = 0$  is the only solution

4. (d)  $3 \cos x + 4 \sin x = 6$   
 since  $-\sqrt{a^2+b^2} \leq a \cos x + b \sin x \leq \sqrt{a^2+b^2}$   
 $\therefore \text{L.H.S.} \in [-5, 5]$   
 $\therefore$  Given equation has no solution

5. (a)  $\sin x + \sin y + \sin z = -3$   
 Clearly  $\sin x = \sin y = \sin z = -1$   
 $\therefore x = y = z = \frac{3\pi}{2}$   
 $\therefore$  Only one solution

6. (a) L.H.S.  $\in [-2, 2]$   
 For  $3x^2 + 2x + 3$   
 Minimum value is  $-\frac{D}{4a}$   
 Minimum values of R.H.S. is  $-\frac{[4-36]}{4 \times 3} = \frac{32}{12} = \frac{8}{3}$   
 Maximum value of L.H.S. = 2  
 Minimum value of R.H.S. =  $\frac{8}{3}$   
 $\therefore$  No solution

7. (a)  $2 \cos^2\left(\frac{x}{2}\right) \sin^2 x = x^2 + \frac{1}{x^2}$   
 $\therefore 0 \leq \sin^2 x \leq 1, 0 \leq \cos^2\left(\frac{x}{2}\right) \leq 1$   
 $\therefore$  L.H.S.  $\leq 2$   
 Also  $x^2 + \frac{1}{x^2} \geq 2 \Rightarrow$  R.H.S.  $\geq 2$   
 $\therefore$  Only equality holds.  
 $\therefore x^2 = 1$   
 $\Rightarrow x = \pm 1$ , but for  $x = 1$ , L.H.S.  $\neq 2$   
 $\therefore$  No solution

8. (c)  $2 \cos(e^x) = x^2 + 2\sqrt{2}x + 4$   
 Minimum value of  $x^2 + 2\sqrt{2}x + 4$  is  
 $\left[\frac{-D}{4a}\right] = -\frac{[8-16]}{4} = 2$   
 Also maximum value of  $2 \cos(e^x)$  is 2  
 $\therefore$  Only equality holds i.e.,  $2 \cos(e^x) = 2$   
 $\Rightarrow \cos(e^x) = 1$   
 $\therefore e^x = 0$   
 $\therefore$  No Solution

9. (c)  $\sin^4 x = 1 + \tan^8 x$   
 $\therefore 0 \leq \sin^4 x \leq 1$   
 $\therefore$  L.H.S.  $\in [0, 1]$ . Also  $\tan^8 x \geq 0$   
 $\therefore 1 + \tan^8 x \geq 1$   
 $\therefore$  Minimum value of R.H.S. is 1  
 $\therefore$  Only equality holds.  
 $\therefore 1 + \tan^8 x = 1 \Rightarrow \tan^8 x = 0$   
 $\therefore x = n\pi$   
 But for  $x = n\pi$  L.H.S.  $\neq 1$   
 $\therefore$  No solution

10. (b)  $\sin^2 x + \cos^2 y = 2 \sec^2 z$   
 $\sec^2 z \geq 1$   
 $\therefore 2 \sec^2 z \geq 2$   
 $\therefore$  R.H.S.  $\geq 2$   
 Also maximum value of L.H.S. = 2  
 $\therefore$  Only equality holds.  
 $\therefore$  L.H.S. = R.H.S. = 2  
 $\therefore \sin^2 x = 1, \cos^2 y = 1,$   
 $\sec^2 z = 1$   
 $x = (2m+1) \cdot \frac{\pi}{2}, y = n\pi, z = \pi$

11. (a)  $\sin x \cos y = 1$   
 Only 2 possibilities  
**Case 1:**  $\sin x = 1, \cos y = 1$   
 $\Rightarrow x = \frac{\pi}{2}, \frac{5\pi}{2}, y = 2n\pi \Rightarrow x = (4k+1) \cdot \frac{\pi}{2}, y = 2n\pi$   
**Case 2:**  $\sin x = -1, \cos y = -1$   
 $\Rightarrow x = \frac{3\pi}{2}, \dots, y = \pi, \dots$   
 $\Rightarrow x = (4n+3) \cdot \frac{\pi}{2}, y = (2k+1) \cdot \pi$

12. (c)  $(\tan x)^{\cos^2 x} = (\cot x)^{\sin^2 x}$   
 $\Rightarrow (\tan x)^{1-\sin^2 x} = (\cot x)^{\sin^2 x} \Rightarrow \frac{\tan x}{(\tan x)^{\sin^2 x}} = (\cot x)^{\sin^2 x}$   
 $\Rightarrow \tan x = (\tan x)^{\sin^2 x} (\tan x \cot x)^{\sin^2 x}$   
 $\Rightarrow \tan x = (\tan x)^{\sin^2 x}$   
 $\Rightarrow \frac{\tan x}{\tan x^{\sin^2 x}} = 1$   
 $\therefore (\tan x)^{1-\sin^2 x} = 1$   
 $\therefore$  Either  $\tan x = 1$  or  $\sin x = 1$   
 $\therefore x = n\pi + \frac{\pi}{4}$  or  $x = n\pi + (-1)^n \cdot \frac{\pi}{2}$

13. (b)  $\tan^2 x + \cot^2 x = 2 \cos^2 y$  ..... (i)  
 And  $\cos^2 y + \sin^2 z = 1$  ..... (ii)  
 For equation (1), L.H.S.  $\geq 2$  and R.H.S.  $\leq 2$   
 $\therefore$  Only equality holds  
 $\therefore \tan^2 x = \cot^2 x = 1$   
 $\therefore x = k\pi \pm \frac{\pi}{4}$   
 Also  $\cos^2 y = 1 \Rightarrow y = m\pi$   
 For equation (ii), when  $y = m\pi, \cos^2 y = 1$   
 $\therefore \sin^2 z = 0 \Rightarrow z = n\pi$ , where  $k, m, n, \in \mathbb{Z}$   
 $\therefore x = k\pi \pm \frac{\pi}{4}, y = m\pi, z = n\pi$

14. (a)  $x^2 + 2x \sin(xy) + 1 = 0$   
 $\Rightarrow \sin(xy) = \frac{-(x^2+1)}{2x}$   
 Now  $x^2 + 1 - 2x = (x-1)^2 \geq 0$   
 $\Rightarrow x^2 + 1 \geq 2x$   
**Case 1:**  $x > 0, \frac{x^2+1}{2x} \geq 1$   
 $\Rightarrow \frac{-(x^2+1)}{2x} \leq -1$   
**Case 2:**  $x < 0, \frac{x^2+1}{2x} \leq -1$   
 $\Rightarrow \frac{-(x^2+1)}{2x} \geq -1$   
 Also  $\sin xy \in [-1, 1]$   
 $\therefore \sin xy = -1$  or  $\sin xy = 1$   
 $\Rightarrow x = -1$  or  $x = 1$   
 $\Rightarrow \sin y = -1$  or  $\sin y = 1$   
 $\Rightarrow x = \pm 1, y = 2n\pi - \frac{\pi}{2}$

**TEXTUAL EXERCISE-5 (OBJECTIVE)**

1. (d) Draw the graph of both function

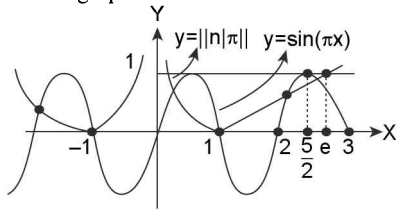

Clearly 6 solution's

2. (a)

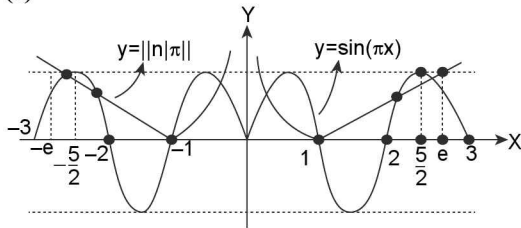

Clearly 8 solution's.

3. (b)

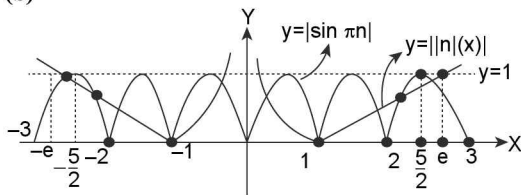

From graph it is clear that 10 solutions are possible.

4. (c)

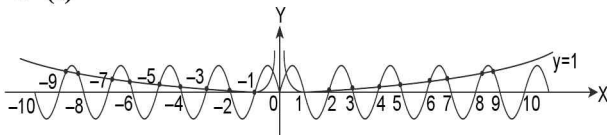

From graph it is clear that 20 solutions.

5. (a)

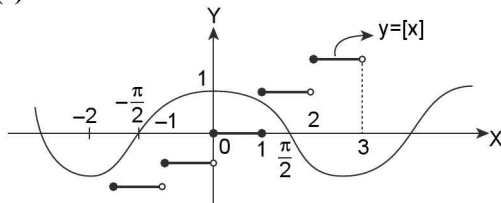

Clearly both curves don't intersect each other

∴ no solution

6. (a)  $y = 2 \sin x$

∴  $-2 \leq 2 \sin x \leq 2$

Also minimum value of  $5x^2 + 2x + 3$  is  $-\frac{[4 - 60]}{4 \times 5} = \frac{14}{5}$

∴ No solution

7. (d)  $\tan x \cdot \tan 4x = 1; 0 < x < \pi$

$\Rightarrow \tan x = \cot 4x$

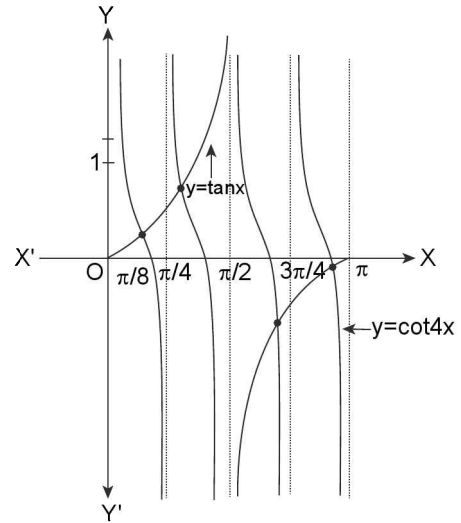

Clearly, these will be 4 solutions each in  $[0, \pi/4], [\pi/4, \pi/2], [\pi/2, 3\pi/4], [3\pi/4, \pi]$

8. (a)  $x^2 + 4 + 3 \sin(ax + b) - 2x = 0$

$\Rightarrow x^2 + 4 - 2x = -3 \sin(ax + b)$

$\Rightarrow (x - 1)^2 + 3 = -3 \sin(ax + b)$

L.H.S.  $\geq 3, -1 \leq \sin(ax + b) \leq 1$

∴ R.H.S.  $\in [-3, 3]$  ∴ only equality holds

i.e., L.H.S. = 3  $\Rightarrow x = 1$

∴ R.H.S. =  $-3 \sin(ax + b) = -3 \sin(a + b)$

∴ R.H.S. = 3  $\Rightarrow \sin(a + b) = -1$

∴  $a + b = \frac{7\pi}{2}$

9. (c)  $\max \{ \sin x, \cos x \} = 1/2$  in  $(-2\pi, 5\pi)$

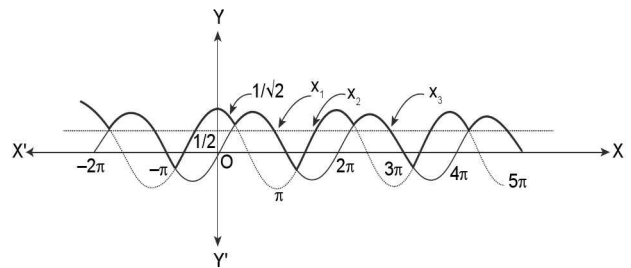

Clearly there will be 7 solutions is obvious from above graph

10. (a)  $|\cos x| = 2[x]$

R.H.S. is an integer and L.H.S.  $\geq 0$

$\Rightarrow |\cos x| \in \{0, 1\}$

∴ For  $|\cos x| = 0 = 2[x]$

$\Rightarrow \cos x = 0 = [x]$

$\Rightarrow \cos x = 0$  and  $x \in [0, 1)$

Which is impossible as  $\cos x = 0$

$$\Rightarrow x \in \left\{ \pm \frac{\pi}{2}, \pm \frac{3\pi}{2}, \dots \right\}$$

Now, for  $|\cos x| = 1 = 2[x]$

$$\Rightarrow \cos x = \pm 1; [x] = 1/2$$

Which is impossible

$\therefore$  No solution

11. (a)  $\ell n |\sin x| = -x^2 + 2x$  in  $\left[ \frac{\pi}{2}, \frac{3\pi}{2} \right] = -(x^2 - 2x + 1 - 1) = 1 - (x - 1)^2$

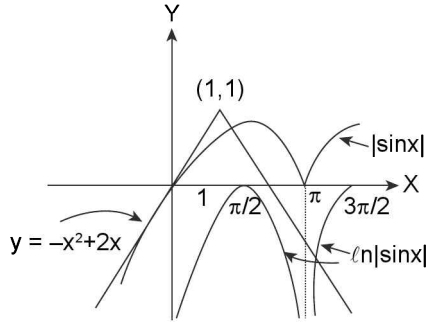

Clearly from graph there will be only one solution

### TEXTUAL EXERCISE-12 (SUBJECTIVE)

1.  $2 \sin^2 x - 3 \sin x + 1 \leq 0$

Let  $\sin x = t$

$$2t^2 - 3t + 1 \leq 0$$

$$\Rightarrow 2t^2 - 2t - t + 1 \leq 0$$

$$\Rightarrow 2t(t - 1) - (t - 1) \leq 0$$

$$\Rightarrow (t - 1)(2t - 1) \leq 0$$

$$\Rightarrow [1/2, 1]$$

$\Rightarrow \sin x \in [1/2, 1]$  in the interval  $x \in [0, 2\pi]$

$$\Rightarrow x \in \left[ \frac{\pi}{6}, \frac{5\pi}{6} \right]$$

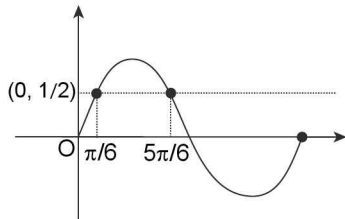

$$\Rightarrow \frac{\pi}{6} \leq x \leq \frac{5\pi}{6}$$

2. (a)  $\cos x \leq -\frac{1}{2}$

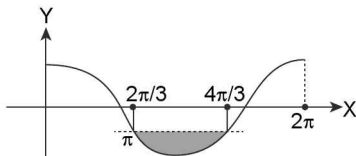

For  $x \in [0, 2\pi]$

The solution set is  $\left[ \frac{2\pi}{3}, \frac{4\pi}{3} \right]$

$$\therefore \bigcup_{n \in \mathbb{Z}} \left[ 2n\pi + \frac{2\pi}{3}, 2n\pi + \frac{4\pi}{3} \right]$$

(b)  $\sin x \geq -\frac{1}{2}$

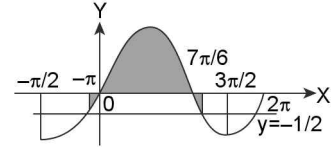

Clearly  $x \in \bigcup_{n \in \mathbb{Z}} \left[ 2n\pi - \frac{\pi}{6}, 2n\pi + \frac{7\pi}{6} \right]$

(c)  $\tan x > \sqrt{3}$

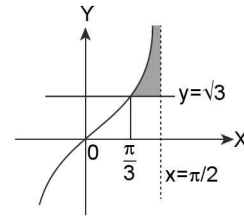

Clearly  $x \in \left[ n\pi + \frac{\pi}{3}, n\pi + \frac{\pi}{2} \right)$

(d)  $\sin x + \sqrt{3} \cos x \geq 0$

$$\Rightarrow \frac{1}{2} \sin x + \frac{\sqrt{3}}{2} \cos x \geq 0$$

$$\Rightarrow \sin x \cdot \cos \frac{\pi}{3} + \cos x \cdot \sin \frac{\pi}{3} \geq 0$$

$$\Rightarrow \sin \left( x + \frac{\pi}{3} \right) \geq 0$$

$\Rightarrow$  Let  $\theta = x + \pi/3$

$$\Rightarrow \sin \theta \geq 0 \Rightarrow \theta \in [2n\pi, (2n+1)\pi]; n \in \mathbb{Z}$$

$$\Rightarrow x + \pi/3 \in [2n\pi, (2n+1)\pi]; n \in \mathbb{Z}$$

$$\Rightarrow x \in \left[ 2n\pi - \frac{\pi}{3}, (2n+1)\pi - \frac{\pi}{3} \right]; n \in \mathbb{Z}$$

$$\Rightarrow x \in \left[ 2n\pi - \frac{\pi}{3}, 2n\pi + \frac{2\pi}{3} \right]; n \in \mathbb{Z}$$

$$\Rightarrow x \in \bigcup_{n \in \mathbb{Z}} \left[ (6n-1)\frac{\pi}{3}, 2(3n+1)\frac{\pi}{3} \right]$$

3.  $0 \leq \frac{1 + \cos \theta}{2 + \cos \theta} \leq \frac{2}{3} \forall \theta$

$$\text{Let } y = \frac{1 + \cos \theta}{2 + \cos \theta} = \frac{1 + \cos \theta}{1 + (1 + \cos \theta)}$$

$$= \frac{1}{1 + \left( \frac{1}{1 + \cos \theta} \right)} = \frac{1}{1 + \left( \frac{1}{2} \sec^2 \frac{\theta}{2} \right)} \text{ for } \cos \theta \neq -1$$

2.90 > Trigonometry

Now  $\sec^2 \frac{\theta}{2} \in [1, \infty)$

$$\Rightarrow \frac{1}{2} \sec^2 \frac{\theta}{2} \in \left[ \frac{1}{2}, \infty \right)$$

$$\Rightarrow 1 + \frac{1}{2} \sec^2 \frac{\theta}{2} \in \left[ \frac{3}{2}, \infty \right)$$

$$\Rightarrow \frac{1}{1 + \frac{1}{2} \sec^2 \frac{\theta}{2}} \in \left( 0, \frac{2}{3} \right]$$

Also for  $\cos \theta = -1$   
 $y = 0$

$\therefore y \in \left[ 0, \frac{2}{3} \right]$  Hence proved

4. (i)  $\sin x + \cos x < \frac{1}{\sin x}$   
 $\Rightarrow \sin x + \cos x < \operatorname{cosec} x$   
 $\Rightarrow \sin(x + \pi/4) < \frac{1}{\sqrt{2}} \operatorname{cosec} x$

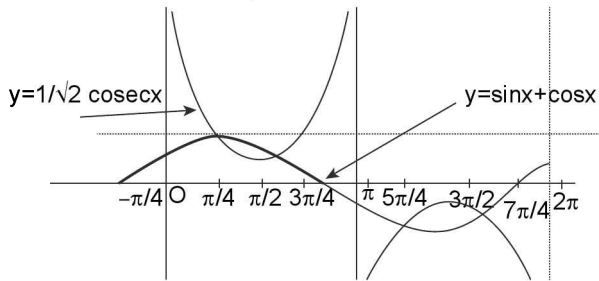

From above graphs clearly in  $[0, 2\pi]$ ;  $\sin x + \cos x < \frac{1}{\sin x}$

$$\text{for } x \in \left( 2n\pi, 2n\pi + \frac{\pi}{4} \right) \cup \left( 2n\pi + \frac{\pi}{2}, (2n+1)\pi \right)$$

$$\cup \left( 2n\pi + \frac{5\pi}{4}, 2n\pi + \frac{3\pi}{2} \right); n \in \mathbb{Z}$$

- (ii)  $\cos 3x + \sqrt{3} \sin 3x < -\sqrt{2}$   
 $\Rightarrow \cos 3x \cdot \frac{1}{2} + \frac{\sqrt{3}}{2} \sin 3x < -\frac{1}{\sqrt{2}}$   
 $\Rightarrow \cos 3x \cdot \cos \frac{\pi}{3} + \sin 3x \cdot \sin \frac{\pi}{3} < -\frac{1}{\sqrt{2}}$

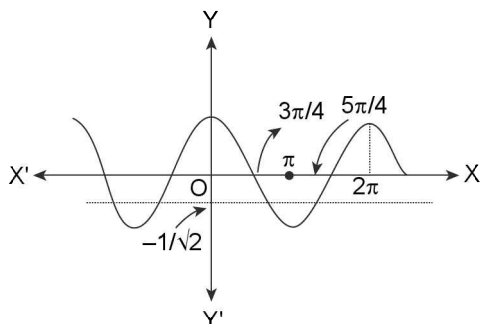

$$\Rightarrow \cos\left(3x - \frac{\pi}{3}\right) < -\frac{1}{\sqrt{2}}$$

$$\Rightarrow \cos \theta < -\frac{1}{\sqrt{2}}; \theta = 3x - \pi/3$$

$$\therefore \theta \in \bigcup_{n \in \mathbb{Z}} \left( 2n\pi + \frac{3\pi}{4}, 2n\pi + \frac{5\pi}{4} \right)$$

$$\Rightarrow \left( 3x - \frac{\pi}{3} \right) \in \bigcup_{n \in \mathbb{Z}} \left( 2n\pi + \frac{3\pi}{4}, 2n\pi + \frac{5\pi}{4} \right)$$

$$\Rightarrow 3x \in \bigcup_{n \in \mathbb{Z}} \left( 2n\pi + \frac{3\pi}{4} + \frac{\pi}{3}, 2n\pi + \frac{5\pi}{4} + \frac{\pi}{3} \right)$$

$$\Rightarrow x \in \bigcup_{n \in \mathbb{Z}} \left( \frac{2n\pi}{3} + \frac{13\pi}{36}, \frac{2n\pi}{3} + \frac{19\pi}{36} \right) \text{ Ans}$$

- (iii)  $5\sin^2 x - 3\sin x \cos x - 36\cos^2 x > 0$   
 $\Rightarrow 5\sin^2 x - 15\sin x \cos x + 12\sin x \cos x - 36\cos^2 x > 0$   
 $\Rightarrow 5\sin x [\sin x - 3\cos x] + 12\cos x [\sin x - 3\cos x] > 0$   
 $\Rightarrow (5\sin x + 12\cos x)(\sin x - 3\cos x) > 0$   
 $(5 + 12\cot x)(1 - 3\cot x) > 0$   
 $\Rightarrow (5 + 12\cot x)(3\cot x - 1) < 0$   
 $\Rightarrow \cot x \in \left( -\frac{5}{12}, \frac{1}{3} \right)$

$\therefore \cot x$  is periodic with period  $\pi$   
 $\therefore$  Solution set will be

$$\bigcup_{n \in \mathbb{Z}} \left( n\pi + \cot^{-1}\left(\frac{1}{3}\right), n\pi + \cot^{-1}\left(-\frac{5}{12}\right) \right)$$

- (iv)  $\sin 4x + \cos 4x \cot 2x > 1$   
 $\Rightarrow \frac{\sin 4x \sin 2x + \cos 4x \cos 2x}{\sin 2x} > 1$   
 $\Rightarrow \frac{\cos(4x - 2x)}{\sin 2x} > 1$   
 $\Rightarrow \cot 2x > 1$   
 $\Rightarrow 2x \in \left( n\pi, n\pi + \frac{\pi}{4} \right)$   
 $\Rightarrow x \in \left( \frac{n\pi}{2}, \frac{n\pi}{2} + \frac{\pi}{8} \right)$

5. (i)  $6\sin^2 x - \sin x \cos x - \cos^2 x > 2$ ;  $\sin \neq 0$  (clearly)  
 $\Rightarrow 6\sin^2 x - 3\sin x \cos x + 2\sin x \cos x - \cos^2 x > 2$   
 $\Rightarrow 3\sin x(2\sin x - \cos x) + \cos x(2\sin x - \cos x) > 2$   
 $\Rightarrow (2\sin x - \cos x)(3\sin x + \cos x) > 2$   
 $\Rightarrow (2 - \cot x)(3 + \cot x) > 2 \operatorname{cosec}^2 x$   
 $\Rightarrow -\cot^2 x - \cot x + 6 > 2 + 2\cot^2 x$   
 $\Rightarrow 3\cot^2 x + \cot x - 4 < 0$   
 $\Rightarrow 3\cot^2 x + 4\cot x - 3\cot x - 4 = 0$   
 $\Rightarrow \cot x(3\cot x + 4) - (3\cot x + 4) < 0$   
 $\Rightarrow (3\cot x + 4)(\cot x - 1) < 0$   
 $\Rightarrow -\frac{4}{3} < \cot x < 1$   
 $\Rightarrow x \in \bigcup_{n \in \mathbb{Z}} \left( n\pi + \frac{\pi}{4}, n\pi + \cot^{-1}\left(-\frac{4}{3}\right) \right) \text{ Ans}$

$$(ii) \cos(x^2) \geq \frac{1}{2}$$

$$-\sqrt{\frac{\pi}{3}} \leq x \leq \sqrt{\frac{\pi}{3}} \quad \text{or} \quad -\sqrt{2n\pi + \frac{\pi}{3}} \leq x \leq \sqrt{2n\pi - \frac{\pi}{3}}$$

$$\text{or } \sqrt{2n\pi - \frac{\pi}{3}} \leq x \leq \sqrt{2n\pi + \frac{\pi}{3}}; n \in \mathbb{N} \quad \text{Ans}$$

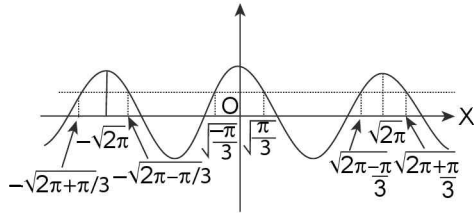

$$(iii) 2\sin^2 \frac{x}{2} + \cos 2x < 0$$

$$\Rightarrow 1 - \cos x + \cos 2x < 0$$

$$\Rightarrow 1 - \cos x + 2\cos^2 x - 1 < 0$$

$$\Rightarrow (\cos x)(2\cos x - 1) < 0$$

$$\Rightarrow 0 < \cos x < \frac{1}{2}$$

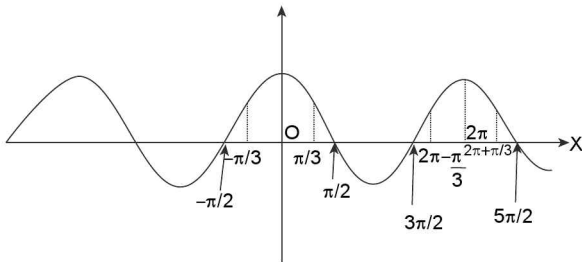

$$\therefore 0 < \cos x < \frac{1}{2}$$

$$\Rightarrow x \in \left(2n\pi - \frac{\pi}{2}, 2n\pi - \frac{\pi}{3}\right)$$

$$\bigcup_{n \in \mathbb{Z}} \left(2n\pi + \frac{\pi}{3}, 2n\pi + \frac{\pi}{2}\right) \quad \text{Ans}$$

$$(iv) \cos^2 x + 3\sin^2 x + 2\sqrt{3} \sin x \cos x < 1$$

$$\Rightarrow \cos^2 x - 1 + 3\sin^2 x + 2\sqrt{3} \sin x \cos x < 0$$

$$\Rightarrow 2\sin^2 x + 2\sqrt{3} \sin x \cos x < 0$$

$$\Rightarrow 2\sin x (\sin x + \sqrt{3} \cos x) < 0$$

∴ Clearly  $\cos x = 0$  does not satisfy the inequality (i)

$$\Rightarrow 2 \tan(\tan x + \sqrt{3}) < 0$$

$$\Rightarrow -\sqrt{3} < \tan x < 0$$

$$\Rightarrow x \in \bigcup_{n \in \mathbb{Z}} \left(n\pi - \frac{\pi}{3}, n\pi\right) \quad \text{Ans}$$

$$(v) \sin^6 x + \cos^6 x < 7/16$$

$$\Rightarrow 1 - 3\sin^2 x \cos^2 x < 7/16$$

$$\Rightarrow 1 - \frac{3}{4} \sin^2 2x < \frac{7}{16}$$

$$\Rightarrow \frac{3}{4} \sin^2 2x > \frac{9}{16}$$

$$\Rightarrow \sin^2 2x > \frac{3}{4}$$

$$\Rightarrow -1 < \sin 2x < -\frac{\sqrt{3}}{2} \quad \text{or} \quad \frac{\sqrt{3}}{2} < \sin 2x < 1$$

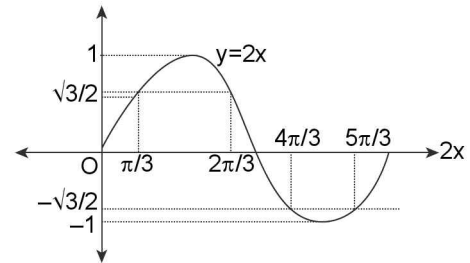

∴ Solution is

$$2x \in \left(2n\pi + \frac{\pi}{3}, 2n\pi + \frac{2\pi}{3}\right) \cup \left(2n\pi + \frac{4\pi}{3}, 2n\pi + \frac{5\pi}{3}\right)$$

$$\Rightarrow x \in \left(n\pi + \frac{\pi}{6}, n\pi + \frac{\pi}{3}\right) \cup \left(n\pi + \frac{2\pi}{3}, n\pi + \frac{8\pi}{6}\right)$$

$$\text{or } 2x \in \left(n\pi + \frac{\pi}{3}, n\pi + \frac{2\pi}{3}\right)$$

$$\Rightarrow x \in \left(\frac{n\pi}{2} + \frac{\pi}{6}, \frac{n\pi}{2} + \frac{\pi}{3}\right)$$

### TEXTUAL EXERCISE-6 (OBJECTIVE)

1. (a)  $\sin x > 1/\sqrt{2}$

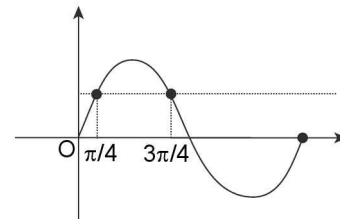

$$\Rightarrow x \in \bigcup_{n \in \mathbb{Z}} \left(2n\pi + \frac{\pi}{4}, 2n\pi + \frac{3\pi}{4}\right); n \in \mathbb{Z}$$

2. (b)  $\cos x \geq \sqrt{3}/2$

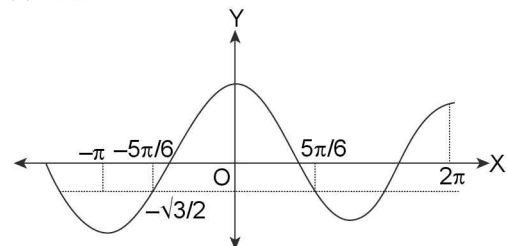



2.92 > Trigonometry

∴ solution set is

$$x \in \bigcup_{n \in \mathbb{Z}} \left[ 2n\pi - \frac{5\pi}{6}, 2n\pi + \frac{5\pi}{6} \right]; n \in \mathbb{Z}$$

3. (a)  $\cos x \geq -1/2$

$$\text{Solution set is } \bigcup_{n \in \mathbb{Z}} \left[ 2n\pi - \frac{2\pi}{3}, 2n\pi + \frac{2\pi}{3} \right]; n \in \mathbb{Z}$$

4. (a)  $2\cos x < \sqrt{3}; x \in [-\pi, \pi]$

$$\Rightarrow \cos x < \sqrt{3}/2$$

$$\Rightarrow x \in \left[ -\pi, -\frac{\pi}{6} \right) \cup \left( \frac{\pi}{6}, \pi \right]$$

5. (a)  $|\tan x| < 1/\sqrt{3}$

$$\Rightarrow \frac{-1}{\sqrt{3}} < \tan x < \frac{1}{\sqrt{3}}$$

$$\Rightarrow \text{solution set will be } \bigcup_{n \in \mathbb{Z}} \left( n\pi - \frac{\pi}{6}, n\pi + \frac{\pi}{6} \right)$$

6. (a) If  $|\tan x| \leq 1$  and  $x \in [-\pi, \pi]$ , then

$$\Rightarrow -1 \leq \tan x \leq 1$$

$$\Rightarrow x \in \bigcup_{n \in \mathbb{Z}} \left[ n\pi - \frac{\pi}{4}, n\pi + \frac{\pi}{4} \right]$$

But for  $x \in [-\pi, \pi]$

$$x \in \left[ -\pi, -\frac{3\pi}{4} \right] \cup \left[ -\frac{\pi}{4}, \frac{\pi}{4} \right] \cup \left[ \frac{3\pi}{4}, \pi \right]$$

7. (c) If  $\cos x - \sin x \geq 1; 0 \leq x \leq 2\pi$ ,

$$\Rightarrow \cos x \left( x + \frac{\pi}{4} \right) \geq \frac{1}{\sqrt{2}}; 0 \leq x \leq 2\pi$$

$$\frac{\pi}{4} \leq \left( x + \frac{\pi}{4} \right) \leq 2\pi + \frac{\pi}{4}$$

$$\therefore \text{Equivalent } \cos \theta \geq \frac{1}{\sqrt{2}}; \frac{\pi}{4} \leq \theta \leq 2\pi + \frac{\pi}{4}$$

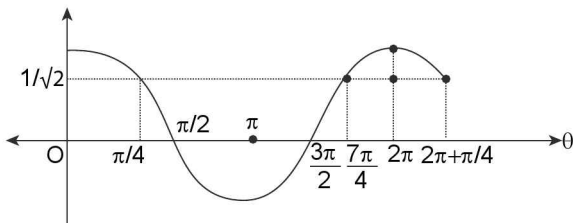

$$\Rightarrow \theta \in \left[ 0, \frac{\pi}{4} \right] \cup \left[ \frac{7\pi}{4}, 2\pi + \frac{\pi}{4} \right]$$

$$\Rightarrow \left( x + \frac{\pi}{4} \right) \in \left[ 0, \frac{\pi}{4} \right] \cup \left[ \frac{7\pi}{4}, 2\pi + \frac{\pi}{4} \right]$$

$$\Rightarrow x \in \left[ -\frac{\pi}{4}, 0 \right] \cup \left[ \frac{3\pi}{2}, 2\pi \right]$$

But  $x \in [0, 2\pi]$

$$\Rightarrow \text{Solution of set is } x \in \left[ \frac{3\pi}{2}, 2\pi \right] \cup \{0\}$$

8. (c)  $\cos^2 \theta < 1/2$

$$\Rightarrow \cos \theta \in \left( -\frac{1}{\sqrt{2}}, \frac{1}{\sqrt{2}} \right)$$

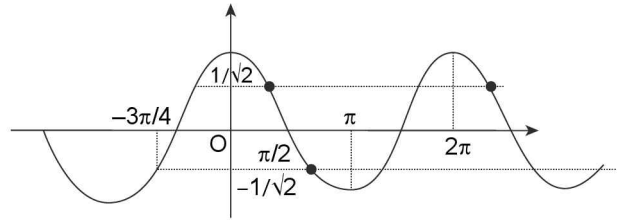

$$\text{Solution set is } \bigcup_{n \in \mathbb{Z}} \left( n\pi + \frac{\pi}{4}, n\pi + \frac{3\pi}{4} \right)$$

$$= \bigcup_{n \in \mathbb{Z}} \left( (4n+1)\frac{\pi}{4}, (4n+3)\frac{\pi}{4} \right)$$

9. (d)  $4\sin^2 x - 8\sin x + 3 \leq 0; 0 \leq x \leq 2\pi$

$$\Rightarrow 4\sin^2 x - 6\sin x - 2\sin x + 3 \leq 0$$

$$\Rightarrow 2\sin x (2\sin x - 3) - 1(2\sin x - 3) \leq 0$$

$$\Rightarrow (2\sin x - 3)(2\sin x - 1) \leq 0$$

$$\Rightarrow \frac{1}{2} \leq \sin x \leq \frac{3}{2}$$

$$\Rightarrow \frac{1}{2} \leq \sin x \leq 1$$

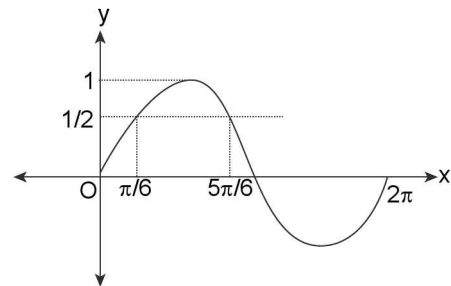

$$\therefore \text{Solution set is } x \in \left[ \frac{\pi}{6}, \frac{5\pi}{6} \right]$$

10. (b)  $\sin x \cdot \cos^3 x > \cos x \cdot \sin^3 x; 0 \leq x \leq 2\pi$

$$\Rightarrow \sin x \cos^3 x - \cos x \sin^3 x > 0$$

$$\Rightarrow \sin x \cos x (\cos^2 x - \sin^2 x) > 0$$

$$\Rightarrow 1/2 \sin 2x \cdot \cos 2x > 0$$

$$\Rightarrow 1/4 (2 \sin 2x \cos 2x) > 0$$

$$\Rightarrow 1/4 \sin 4x > 0$$

$$\Rightarrow \sin 4x > 0$$

$$\Rightarrow \sin 4x > 0$$

$$\Rightarrow 4x \in (2n\pi, (2n+1)\pi)$$

$$\Rightarrow x \in \left( \frac{n\pi}{2}, (2n+1)\frac{\pi}{4} \right)$$

But  $x \in [0, 2\pi]$

For  $n = 0; x \in (0, \pi/4)$

$$\text{For } n = 1; x \in \left(\frac{\pi}{2}, \frac{3\pi}{4}\right)$$

$$\text{For } n = 2; x \in \left(\pi, \frac{5\pi}{4}\right)$$

$$\text{For } n = 3; x \in \left(\frac{3\pi}{2}, \frac{7\pi}{4}\right)$$

**SECTION-III (ONLY ONE CORRECT ANSWERS)**

1. (a)  $\tan\theta + \tan(\pi/2 + \theta) = 0$   
 $\Rightarrow \tan\theta - \cot\theta = 0 \Rightarrow \tan\theta - \frac{1}{\tan\theta} = 0$   
 $\Rightarrow \tan^2\theta - 1 = 0$   
 $\tan^2\theta = 1 \Rightarrow \tan^2\theta = \tan^2(\pi/4)$   
 $\Rightarrow \theta = n\pi \pm \frac{\pi}{4}$
2. (a) Given equation is  $2[\sin^4(2x) + \cos^4(2x)] + 3\sin^2x \cos^2x = 0$   
 $\Rightarrow 2[(\sin^2(2x) + \cos^2(2x))^2 - 2\sin^2(2x)\cos^2(2x)] + 3\sin^2x \cos^2x = 0$   
 $\Rightarrow 2 - 4\sin^2(2x)\cos^2(2x) + 3/4\sin^2(2x) = 0$   
 $\Rightarrow 2 - 4\sin^2(2x)[1 - \sin^2(2x)] + 3/4\sin^2(2x) = 0$   
 $\Rightarrow 2 - 4\sin^2(2x) + 4\sin^4(2x) + 3/4\sin^2(2x) = 0$   
 $\Rightarrow 4\sin^4(2x) - 13/4\sin^2(2x) + 2 = 0$   
 $\Rightarrow 16\sin^4(2x) - 13\sin^2(2x) + 8 = 0$   
 Let  $\sin^2(2x) = t$   
 $\Rightarrow 16t^2 - 13t + 8 = 0$ ; Disc. =  $169 - 4(16)(8) < 0$   
 $\Rightarrow$  No real value of  $t$  and hence no solution.
3. (b)  $2\sin x + 1 \geq 0$  &  $x \in [0, 2\pi]$   
 $\Rightarrow \sin x \geq -1/2$

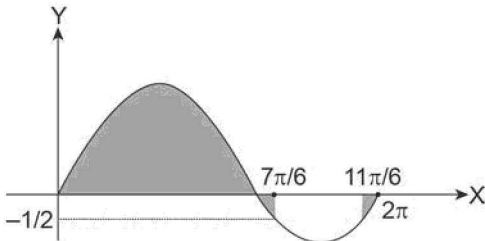

From graph it is clear that  $x \in [0, 7\pi/6] \cup [11\pi/6, 2\pi]$

4. (d) Given expression is  $\cos y \cos(\pi/2 - x) - \cos x \cos(\pi/2 - y) + \sin y \cos(\pi/2 - x) + \cos x \sin(\pi/2 - y) = 0$   
 $\Rightarrow \sin x \cos y - \sin y \cos x + \sin x \sin y + \cos x \cos y = 0$   
 $\Rightarrow \sin(x - y) + \cos(x - y) = 0$   
 $\Rightarrow \sqrt{2} \left[ \frac{1}{\sqrt{2}} \sin(x - y) + \frac{1}{\sqrt{2}} \cos(x - y) \right] = 0$   
 $\Rightarrow \sin(x - y) \cos(\pi/4) + \cos(x - y) \sin(\pi/4) = 0$

$$\Rightarrow \sin\left(x - y + \frac{\pi}{4}\right) = 0 \Rightarrow x - y + \frac{\pi}{4} = n\pi \quad n \in \mathbb{Z}$$

$$\Rightarrow x = n\pi - \frac{\pi}{4} + y; n \in \mathbb{Z}$$

5. (a)  $\sin(x - y) = 1/2 \Rightarrow x - y = \pi/6$  or  $\frac{5\pi}{6}$   
 $\cos(x + y) = 1/2 \Rightarrow x + y = \frac{\pi}{3}, \frac{5\pi}{3}$   
 $\therefore$  After solving we get  $x = 45^\circ, y = 15^\circ$

6. (c) Draw the graphs of  $y = \sin x$  &  $y = 1/x$   
 $\therefore x \sin x = 1 \Rightarrow \sin x = 1/x$

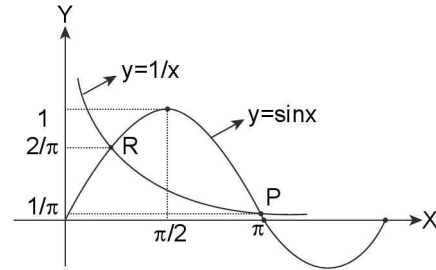

Clearly both graphs intersect and 2 points P & R

7. (c) Clearly both the curves intersect at 6 points

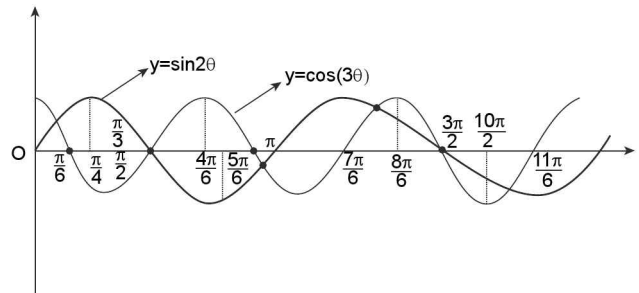

8. (d) Given equation is  $[\sin x] + \cos x = 0$

$$\Rightarrow \cos x = -[\sin x]$$

Now draw the graphs of  $\cos x$  and  $-[\sin x]$

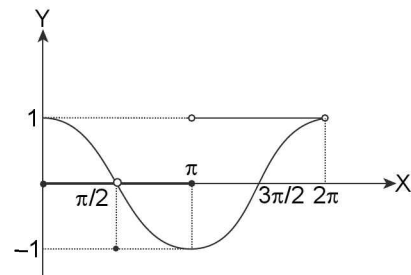

Clearly both curves do not intersect no solution

9. (c)  $\tan\theta = -1 \Rightarrow \theta = n\pi - \pi/4$   
 $\Rightarrow \cos\theta = 1/\sqrt{2} \Rightarrow \theta = 2n\pi \pm \pi/4$

Clearly  $7\pi/4$  is the common value satisfying both the equation

$\therefore$  General Solution is  $\theta = 2n\pi + 7\pi/4$

2.94 ➤ Trigonometry

10. (c)  $8 \tan^2\theta + 9 = 6 \sec\theta$ ;  $\theta \in \left(-\frac{\pi}{2}, \frac{\pi}{2}\right)$

$$8[\sec^2\theta - 1] + 9 = 6 \sec\theta$$

$$\Rightarrow 8 \sec^2\theta - 6 \sec\theta + 1 = 0 \Rightarrow \sec\theta = \frac{1}{2} \text{ or } \frac{1}{4}$$

∴ No solution

11. (a) Draw the graphs of  $y = |\cos x|$  &  $y = \sin x$

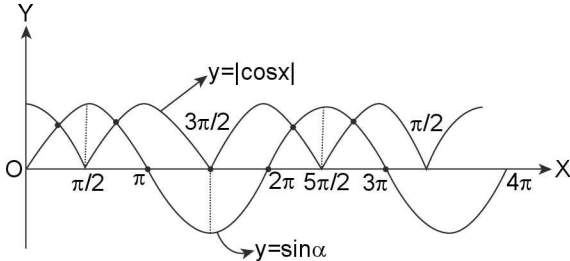

Clearly both is curves intersect each other at 4 point.

12. (c) Given equation is  $\cos^8 x + b \cos^4 x + 1 = 0$

Let  $\cos^4 x = t \Rightarrow t \in [0, 1]$

∴ Given equation becomes  $t^2 + bt + 1 = 0$  ... (i)

Equation (i) will have a solution in  $[0, 1]$  if  $D \geq 0$

$$b^2 - 4 \geq 0 \text{ and } 1 + b + 1 \leq 0$$

$$\Rightarrow |b| \leq 2 \text{ and } b \leq -2$$

$$\therefore b \leq -2 \Rightarrow b \in (-\infty, -2]$$

13. (c) Clearly  $x_1 = x_2 = x_3 = \dots = x_n = \pi/n$

∴ Maximum value of  $\sin x_1 + \sin x_2 + \sin x_3 + \dots + \sin x_n = n \cdot \sin(\pi/n)$

14. (b) Given equation is

$$\frac{1 - \sin x + \sin^2 x + \dots + (-1)^n \sin^n x + \dots}{1 + \sin x + \sin^2 x + \dots + \sin^n x} = \frac{1 - \cos(2x)}{1 + \cos(2x)}$$

$$\Rightarrow \frac{1 + \sin x}{1 - \sin x} = \frac{2 \sin^2 x}{2 \cos^2 x} \Rightarrow \frac{1 - \sin x}{1 + \sin x} \times \frac{1 - \sin x}{1 - \sin x} = \frac{\sin^2 x}{\cos^2 x}$$

$$\Rightarrow 1 + \sin^2 x - 2 \sin x = \sin^2 x$$

$$\Rightarrow \sin x = 1/2 \Rightarrow x = n\pi + (-1)^n \cdot \pi/6$$

15. (a)  $|\sin x + \cos x| = |\sin x| + |\cos x|$  is possible only if  $\sin x + \cos x$  are positive or both negative

∴  $x$  belongs to I or III quadrant.

16. (d)  $\sin x [\sin x + \cos x] = k$

$$\Rightarrow \sin^2 x + \sin x \cos x = k$$

$$\Rightarrow \frac{1 - \cos(2x)}{2} + \frac{\sin(2x)}{2} = k$$

$$\Rightarrow \sin(2x) - \cos(2x) = 2k - 1$$

Now,  $-\sqrt{2} \leq \sin(2x) - \cos(2x) \leq \sqrt{2}$

∴ Given equation will have a solution if  $-\sqrt{2} \leq 2k - 1 \leq \sqrt{2}$

$$\Rightarrow \frac{1 - \sqrt{2}}{2} \leq k \leq \frac{1 + \sqrt{2}}{2}$$

17. (c) Range of  $a \cos x + b \sin x$  is  $[-\sqrt{a^2 + b^2}, \sqrt{a^2 + b^2}]$

$$\therefore \text{For solution } -\sqrt{k^2 + 9} \leq k + 1 \leq \sqrt{k^2 + 9}$$

$$\therefore (k + 1)^2 \leq k^2 + 9$$

$$\Rightarrow k \leq 4 \Rightarrow k \in (-\infty, 4]$$

18. (d)  $\sin(e^x) \cos(e^x) = 2^{x-2} + 2^{-x-2}$

$$\Rightarrow \sin(2e^x) = 2 \left[ \frac{2^x}{4} + \frac{1}{2^x \cdot 4} \right]$$

$$\Rightarrow \sin(2e^x) = \frac{1}{2} \left[ 2^x + \frac{1}{2^x} \right]$$

$$\text{Now } 2^x + \frac{1}{2^x} \geq 2; x > 0$$

$$2^x + \frac{1}{2^x} \leq 2; x < 0$$

$$\therefore \sin(2e^x) = \pm 1 \quad \therefore \text{Infinite solution}$$

19. (d)  $\sin\left(\frac{\pi}{10}\right) = \frac{\sqrt{5} - 1}{4}$

$$\cos\left(\frac{\pi}{10}\right) = \frac{\sqrt{10 + 2\sqrt{5}}}{4}$$

$$\therefore f\left(\frac{\pi}{10}\right) = \frac{\sqrt{5} - 1 + \sqrt{10 + 2\sqrt{5}}}{4} > 1$$

$$\therefore \left[ f\left(\frac{\pi}{10}\right) \right] = 1$$

∴ Given equation becomes  $\sin x + \cos x = 1$

$$\therefore x = 2n\pi \text{ or } 2n\pi + \pi/2$$

20. (d)  $\sin x + \sin y = y^2 - y + a$

Form R.H.S.

$$\text{Minimum values } \frac{-(1 - 4a)}{4} = a - \frac{1}{4}$$

Also L.H.S. maximum values = 2

∴ Given equation will have no solution

$$\text{If } a - \frac{1}{4} > 2; \text{ i.e., if } a > 2 + \frac{1}{4}$$

$$\therefore a \in \left(2 + \frac{1}{4}, \infty\right) \subseteq \left(\sqrt{2} + \frac{1}{4}, \infty\right)$$

$$\Rightarrow a \in \left(\sqrt{2} + \frac{1}{4}, \infty\right)$$

21. (b)  $x \cos \alpha + y \sin \alpha = 2a$  ... (i)

$$x \cos \beta + y \sin \beta = 2a \quad \dots \text{(ii)}$$

Squaring both side, we get  $x^2 \cos^2 \alpha + y^2 \sin^2 \alpha + 2xy \sin \alpha \cdot \cos \alpha = 4a^2$

$$\Rightarrow x^2 \cos^2 \alpha + y^2 (1 - \cos^2 \alpha) + 2xy \sin \alpha \cdot \cos \alpha$$

$$\Rightarrow \cos^2 \alpha (x^2 - y^2) + y^2 + 2xy \sin \alpha \cdot \cos \alpha = 4a^2$$

$$\Rightarrow (\cos^2 \alpha - \cos^2 \beta)(x^2 - y^2) + xy(\sin 2\alpha - \sin 2\beta)$$

$$\Rightarrow \frac{\sin 2\beta - \sin 2\alpha}{\cos^2 \alpha - \cos^2 \beta} = \frac{x^2 - y^2}{xy}$$

22. (b)  $(2 \cos x - 1)(3 + 2 \cos x) = 0$   
 Either  $2 \cos x = 1$  or  $\cos x = -3/2$  which is impossible  
 $\cos x = \frac{1}{2} \Rightarrow x = \frac{\pi}{3}$  or  $\frac{5\pi}{3}$

23. (c)  $3 \cos(2x) - 10 \cos x + 7 = 0$   
 $\Rightarrow 3[2 \cos^2 x - 1] - 10 \cos x + 7 = 0$   
 $\Rightarrow 6 \cos^2 x - 10 \cos x + 4 = 0$   
 $\Rightarrow \cos x = 1$  or  $2/3$

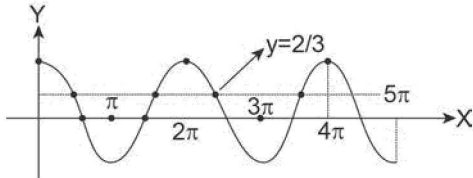

$\cos x = 1 \rightarrow (3 \text{ solution})$   
 $\cos x = 2/3 (5 \text{ solution})$

$\therefore$  Total 8 solution

24. (c) Given equation is  $\tan x + \sec x = 2 \cos x$   $\left[ x \neq \frac{\pi}{2}, \frac{3\pi}{2} \right]$

$\Rightarrow \frac{\sin x}{\cos x} + \frac{1}{\cos x} = 2 \cos x$

$\Rightarrow \sin x + 1 = 2 \cos^2 x$

$\Rightarrow \sin x + 1 = 2 [1 - \sin^2 x]$

$\Rightarrow 2 \sin^2 x + \sin x - 1 = 0$

$\Rightarrow \sin x = -1, 1/2 \Rightarrow x = \frac{3\pi}{2}, \frac{\pi}{6}, \frac{5\pi}{6}$  but  $x \neq \frac{3\pi}{2}$

$\therefore$  Only 2 solution

25. (d)  $(\cos p - 1)x^2 + (\cos p)x + \sin p = 0$  will have real roots if  $D \geq 0$

$\Rightarrow \cos^2 p - 4 \sin p (\cos p - 1) \geq 0$

$\Rightarrow \cos^2 p + 4 \sin p (1 - \cos p) \geq 0$

As  $\cos^2 p \geq 0$  &  $1 - \cos p \geq 0$

$\therefore$  if  $\sin p \geq 0$

$\Rightarrow p \in (0, \pi)$ , then roots will be real. Although equation may have real. Real roots if  $\sin p$  is negative.

26. (a) Range of  $4 \sin x + 3 \cos x$  is  $[-5, 5]$ ; L.H.S.  $\leq 5$  and minimum value of  $y^2 - 6y + 14$  is  $[5]$ ; L.H.S.  $\geq 5$  at  $y = 3$

$\therefore$  Only equality holds

$\therefore 4 \sin x + 3 \cos x = 5$  at  $y = 3$

27. (d)  $2 \sin^2 x - 3 \sin x + 1 \geq 0$

$\Rightarrow (\sin x - 1)(\sin x - 1/2) \geq 0$

$\Rightarrow \sin x \leq 1/2$  or  $\sin x \geq 1$

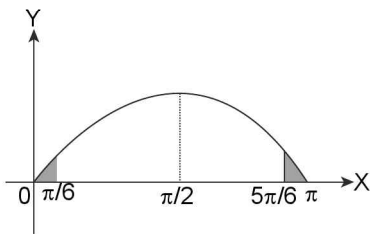

From graphs it is clear that  $x \in \left[0, \frac{\pi}{6}\right] \cup \left[\frac{5\pi}{6}, \pi\right] \cup \left\{\frac{\pi}{2}\right\}$

28. (c) Given equation can be written as  $(\tan \alpha + \sqrt{3})^2 = 4$   
 $\tan \alpha + \sqrt{3} = \pm 2$

$\tan \alpha = 2 - \sqrt{3}$  or  $\tan \alpha = -2 - \sqrt{3}$

$\tan \alpha = \pi/12$  or  $\alpha = -5\pi/2 = 7\pi/12$

$\therefore \alpha = \pi/12$  or  $7\pi/12$

$\therefore \alpha = (6n + 1)\pi/12$

29. (b)  $x \in \left[0, \frac{\pi}{2}\right] \Rightarrow 3x \in \left[0, \frac{3\pi}{2}\right]$  &  $4x \in [0, 2\pi]$

Given equation is  $\sin 7x + \sin x + \sin 4x = 0$

$\therefore 2 \sin x \cos 3x + \sin 4x = 0$

$\Rightarrow \sin(4x)[2 \cos(3x) + 1] = 0$

$\therefore \sin 4x = 0$  or  $\cos(3x) = -1/2$

$\Rightarrow 4x = n\pi$

$\therefore 4x = 0, \pi, 2\pi$

$\Rightarrow x = 0, \frac{\pi}{4}, \frac{\pi}{2}; 3x = \frac{2\pi}{3}, \frac{4\pi}{3}$

$\Rightarrow x = \frac{2\pi}{9}, \frac{4\pi}{9}$

$\therefore$  Total 5 solutions

30. (d) Given  $\sin(2x) + \cos(2x) = 1$

$\therefore 2x = 2n\pi$  or  $2n\pi + \frac{\pi}{2}$

$\therefore x = n\pi$  or  $n\pi + \pi/4$

31. (a) Given equation is  $\sin x + \sin 5x = \sin 2x + \sin 4x$

$\Rightarrow 2 \sin(3x) \cos(2x) = 2 \sin(3x) \cos x$

$\Rightarrow \sin(3x) [\cos(2x) - \cos x] = 0$

Either  $\sin(3x) = 0 \Rightarrow 3x = n\pi$

$\Rightarrow x = n\pi/3$

Or  $\cos(2x) - \cos x = 0$

$\Rightarrow 2 \cos^2 x - \cos x - 1 = 0$

$\Rightarrow \cos x = 1/2$  or  $1$

$\therefore x = 2n\pi$  or  $x = 2n\pi + \pi/3$

32. (c) Given equation is  $\sin 3\alpha = 4 \sin \alpha \sin(x + \alpha) \sin(x - \alpha)$

$\Rightarrow 3 \sin \alpha - 4 \sin^3 \alpha = 4 \sin \alpha [\sin^2 x - \sin^2 \alpha]$

$\Rightarrow 3 \sin \alpha = 4 \sin \alpha \sin^2 x$

$\Rightarrow \sin[3 - 4 \sin^2 x] = 0$

$\therefore \sin \alpha = 0$  or  $\sin^2 x = 3/4$

$\Rightarrow \sin x = \pm \sqrt{3}/2$

$\therefore$  One solution in each quadrant.

33. (c) Given equation can be written as  $x^2 + 4 - 2x = -3 \cos(ax + b)$

$\Rightarrow (x - 1)^2 - 3 = -3 \cos(ax + b)$

L.H.S.  $\geq 3$  & R.H.S.  $\in [-3, 3]$

$\therefore$  Only solution is  $x - 1 = 0$

$\Rightarrow x = 1$  &  $\cos(ax + b) = -1$

$\therefore a + b = \text{odd multiple of } \pi$ , but  $a + b \in [0, 6]$

$\therefore a + b = \pi$

34. (b) Given equation can be written as  $(\sin 3x + \sin x) - 3 \sin(2x) = (\cos 3x + \cos x) - 3 \cos(2x)$

$\Rightarrow 2 \sin(2x) \cos x - 3 \sin(2x) = 2 \cos(2x) \cos x - 3 \cos(2x)$

2.96 > Trigonometry

$$\Rightarrow \sin(2x) [2\cos x - 3] = \cos(2x) [2\cos x - 3]$$

As  $\cos x \neq 3/2$

$$\Rightarrow \sin(2x) = \cos(2x) \Rightarrow \tan(2x) = 1$$

$$\Rightarrow 2x = n\pi + \pi/4 \Rightarrow x = \frac{n\pi}{2} + \frac{\pi}{8}$$

35. (d) Given equation  $x^4 - x^3 \sin(2\beta) + x^2 \cos(2\beta) - x \cos\beta - \sin\beta = 0$

$\therefore S_1 = \sin(2\beta), S_2 = \cos 2\beta, S_3 = \cos\beta, S_4 = \sin\beta$

$$\begin{aligned} \text{Now } \tan(\theta_1 + \theta_2 + \theta_3 + \theta_4) &= \frac{s_1 - s_3}{1 - s_2 + s_4} \\ &= \frac{\sin(2\beta) - \cos\beta}{1 - \cos 2\beta - \sin\beta} = \frac{2\sin\beta \cos\beta - \cos\beta}{2\sin^2\beta - \sin\beta} = \cot\beta \end{aligned}$$

36. (c)  $3x$  lies in Ist or IIIrd quadrant

$$\Rightarrow 0 < 3x < \frac{\pi}{2} \text{ or } \pi < 3x < \frac{3\pi}{2}$$

$$\Rightarrow 0 < x < \frac{\pi}{6} \text{ or } \frac{\pi}{3} < x < \frac{\pi}{2}$$

37. (b)  $f(x) = [\cos x \cos(x+2) - \cos^2(x+1)]$

$$= \left[ \frac{2\cos x \cos(x+2)}{2} - \left[ \frac{1 + \cos(2(x+1))}{2} \right] \right] = \left[ \frac{\cos 2 - 1}{2} \right]$$

Now  $0 < \cos 2 < -1$

$$\therefore -1 < \cos 2 - 1 < -2$$

$$\therefore -\frac{1}{2} < \frac{\cos 2 - 1}{2} < -1$$

$$\therefore f(x) = -1 \Rightarrow x = -1$$

38. (b) Given equation  $2 \sin\theta + \tan\theta = 0$

$$\Rightarrow 2 \sin\theta + \frac{\sin\theta}{\cos\theta} = 0 \Rightarrow \sin\theta \left[ 2 + \frac{1}{\cos\theta} \right] = 0$$

$$\sin\theta = 0 \text{ or } \cos\theta = -1/2$$

$$\theta = n\pi \text{ or } \theta = 2m\pi \pm \frac{2\pi}{3}$$

39. (a) Given equation can be written as  $x^3 + 2x^2 + 5x = -2\cos x$   
R.H.S.  $\in [-2, 2]$

$$\text{Let } f(x) = x^3 + 2x^2 + 5x$$

$$f'(x) = 3x^2 + 4x + 5 \text{ (D < 0)}$$

$$\therefore f'(x) > 0$$

$\therefore f(x)$  is always increasing

$$\therefore f(x)_{\min} = 0, f(x) = \pi^3 + 2\pi^2 + 5\pi > 2$$

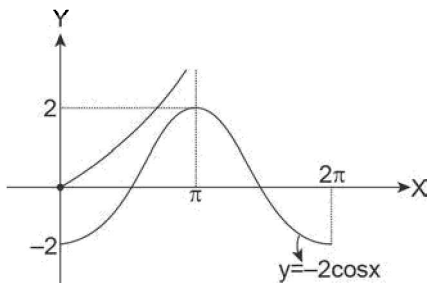

$\therefore$  No Solution

40. (a) Given equation is  $\sin^2 x - \cos^2 x = \frac{1}{\cos x} - \frac{1}{\sin x}$

$$\begin{aligned} (\sin x - \cos x) [\sin^4 x + \sin^3 x \cos x + \sin^2 x \cos^2 x + \sin x \cos^3 x + \sin^4 x] &= \frac{\sin x - \cos x}{\sin x \cos x} \\ \Rightarrow (\sin^4 x + \cos^4 x) + \sin^3 x \cos x + \sin x \cos^3 x + \sin^2 x \cos^2 x &= \frac{1}{\sin x \cos x} \end{aligned}$$

$$\Rightarrow 1 - 2\sin^2 x \cos^2 x + \sin x \cos x [\sin^2 x + \cos^2 x] + \sin^2 x \cos^2 x = \frac{1}{\sin x \cos x}$$

$$\Rightarrow 1 - \sin^2 x \cos^2 x + \sin x \cos x = \frac{1}{\sin x \cos x}$$

$$\Rightarrow 1 - \sin^2 x \cos^2 x = \frac{1}{\sin x \cos x} - \sin x \cos x$$

$$\Rightarrow 1 = \frac{1}{\sin x \cos x}$$

$$\Rightarrow \sin(2x) = 2 \text{ which is impossible}$$

$\therefore$  No solution

41. (d)  $\tan\left(\frac{p\pi}{4}\right) = \cot\left(q \cdot \frac{\pi}{4}\right)$

$$\Rightarrow \tan\left(\frac{p\pi}{4}\right) = \tan\left(\frac{\pi}{2} - \frac{q\pi}{4}\right)$$

$$\Rightarrow \frac{p\pi}{4} = n\pi + \frac{\pi}{2} - \frac{q\pi}{4}$$

$$\Rightarrow (p+q) \cdot \frac{\pi}{4} = \frac{(2n+1)\pi}{2}$$

$$\Rightarrow p+q = 2(2n+1)$$

42. (a)  $\sin x = \cos y$

$$\Rightarrow \sin^2 x - \cos^2 y \Rightarrow \mu = \cos^2 y = 1 - \sin^2 y = 1 - v$$

$$\Rightarrow \mu + v = 1 \quad \dots (i)$$

$$\text{Also } \sqrt{6} \sin y = \tan z$$

$$\Rightarrow 6 \sin^2 y = \tan^2 z$$

$$\Rightarrow 6v \tan^2 z = \frac{\sin^2 z}{\cos^2 z} = \frac{\sin^2 z}{1 - \sin^2 z} = \frac{w}{1-w}$$

$$\Rightarrow 6v = \frac{w}{1-w} \quad \dots (ii)$$

$$\text{Again } 2 \sin x = \sqrt{3} \cos x$$

$$\Rightarrow \sin^2 z = \frac{3}{4} \cos^2 x$$

$$\Rightarrow w = \frac{3}{4} [1 - \sin^2 x] \Rightarrow w = \frac{3}{4} [1 - \mu] \quad \dots (iii)$$

$$\text{From (ii) \& (iii), we get } 6v = \frac{\frac{3}{4}v}{1 - \frac{3}{4}v} \Rightarrow 6v = \frac{3v}{4-3v}$$

$$\Rightarrow 24v - 18v^2 = 3v \Rightarrow 18v^2 - 21v = 0$$

$$\Rightarrow v = 0 \text{ or } v = 7/6$$

$$\therefore v = 0 \text{ as } v \neq 7/6$$

$$\therefore \mu = 1, w = 0$$

43. (d) Given equation is

$$\cos(2x) - 3\cos x + 1 = \frac{1}{(\cot 2x - \cot x)\sin(x - \pi)}$$

$$\therefore 2\cos^2 x - 3\cos x = \frac{1}{-\sin x \left[ \frac{\cos 2x}{\sin 2x} - \frac{\cos x}{\sin x} \right]}$$

$$\Rightarrow 2\cos^2 x - 3\cos x = \frac{1}{-\sin x \left[ \frac{\sin x \cos 2x - \cos x \sin 2x}{\sin 2x \sin x} \right]}$$

$$\Rightarrow 2\cos^2 x - 3\cos x = \frac{\sin(2x)}{\sin x} = 2\cos x$$

$$\Rightarrow 2\cos^2 x - 5\cos x = 0 \Rightarrow \cos x = 0 \text{ or } \cos x = 5/2 \text{ (Impossible)}$$

$x = \text{odd multiple of } \pi/2$  but for that  $\cot(2x)$  is not defined

$\therefore$  No solution

44. (b) Given equation can be written as  $\operatorname{cosec}^2(\pi(a+x)) = \frac{4a-a^2}{4}$

Since  $\operatorname{cosec}^2\theta \geq 1$

$$\Rightarrow \frac{4a-a^2}{4} \geq 1 \Rightarrow 4a-a^2 \geq 4$$

$$\Rightarrow a^2 - 4a + 4 \leq 0$$

$$\Rightarrow (a-2)^2 \leq 0 \quad \therefore a = 2$$

45. (a) Given equation is  $\sin x \cdot \tan^4 x = \cos x$

$$\Rightarrow \sin^5 x = \cos^5 x \Rightarrow \sin^5 x - \cos^5 x = 0$$

$$\Rightarrow (\sin x - \cos x) [\sin^4 x + \sin^3 x \cos x + \sin^2 x \cos^2 x + \sin x \cos^3 x + \cos^4 x] = 0$$

Either  $\sin x = \cos x$  or  $\sin^4 x + \cos^4 x + \sin x \cos x (\sin^2 x + \cos^2 x) + (\sin x \cos x)^2 = 0$

$$(\sin^2 x + \cos^2 x)^2 - 2\sin^2 x \cos^2 x + \sin x \cos x + \sin^2 x \cos^2 x = 0$$

$$\Rightarrow 1 - \sin^2 x \cos^2 x + \sin x \cos x = 0$$

$$\Rightarrow 1 - \frac{\sin^2(2x)}{4} + \frac{\sin(2x)}{2} = 0$$

Put  $\sin(2x) = t$

$$\Rightarrow 4 - t^2 + 2t = 0 \Rightarrow t^2 - 2t - 4 = 0$$

$$\Rightarrow t = \frac{2 \pm \sqrt{20}}{2} \Rightarrow t = 1 \pm \sqrt{5} \text{ is not possible}$$

$\sin x = \cos x$

$$\therefore x = \frac{\pi}{4} \text{ or } \frac{5\pi}{4} \text{ or } \frac{9\pi}{4}, \frac{13\pi}{4} \text{ as } x \in (0, 4\pi),$$

i.e., 4 solutions.

46. (b)  $\log_a x > 0$  if both  $x$  and  $a$  are on the same side of unity, i.e., both  $x$  &  $a$  are greater than 1 or both are less than 1

$$\therefore \log_{\tan x} \sin x > 0$$

$$\Rightarrow \sin x > 1 \text{ \& \; } \tan x > 1 \text{ or } 0 < \sin x < 1 \text{ \& \; } \tan x < 1 \text{ also } \tan x > 0; \sin x \neq 1$$

$\therefore$  Given equation reduces to  $0 < \sin x < 1$  &  $0 < \tan x < 1$

$$0 < \sin x < 1 \text{ true for all } x \in \mathbb{R} \sim \left\{ 2n\pi + \frac{\pi}{2} \right\}$$

$$\tan x < 1$$

$$\Rightarrow 2n\pi < x < 2n\pi + \frac{\pi}{4} \text{ or } (2n+1)\pi < x < (2n+1)\pi + \frac{\pi}{4}$$

$$\text{But in } \left( (2n+1)\pi, (2n+1)\pi + \frac{\pi}{4} \right), \sin x < 0$$

$$\therefore \text{General solution is } x \in \left( 2n\pi, 2n\pi + \frac{\pi}{4} \right)$$

47. (a) Given equation can be written as  $[\cos x] + [\sin x] + 1 = 0$   
 $[\sin x] + [\cos x] = -1 \quad \dots (i)$

Now draw its graphs of  $[\cos x] + [\sin x]$

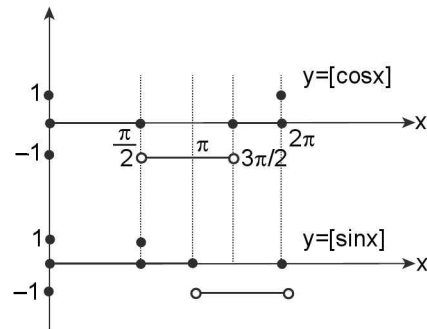

From graph it is clear that equation (i) is satisfied for

$$x \in \left[ \frac{\pi}{2}, \pi \right) \cup \left[ \frac{3\pi}{2}, 2\pi \right)$$

48. (c)  $\cos^4 x - \sin^4 x + \cos(2x) + \alpha^2 + \alpha = 0$   
 $\Rightarrow (\cos^2 x - \sin^2 x)(\cos^2 x + \sin^2 x) + \cos(2x) + \alpha^2 + \alpha = 0$   
 $\Rightarrow \alpha^2 + \alpha = -2\cos(2x)$

R.H.S.  $\in [-2, 2]$

$$\therefore \text{For a solution } -2 \leq \alpha^2 + \alpha \leq 2$$

$$\Rightarrow 0 \leq \alpha^2 + \alpha + 2 \text{ \& \; } \alpha^2 + \alpha - 2 \leq 0$$

$$\Rightarrow \alpha^2 + \alpha + 2 \geq 0 \Rightarrow (\alpha + 2)(\alpha - 1) \leq 0$$

$$\Rightarrow \alpha \in [-2, 1]$$

49. (c) Given equation  $\sin(\pi \cos \theta) = \cos(\pi \sin \theta)$

$$\Rightarrow \sin(\pi \cos \theta) = \sin(\pi/2 - \pi \sin \theta)$$

$$\Rightarrow \pi \cos \theta = \pi/2 - \pi \sin \theta$$

$$\Rightarrow \sin \theta + \cos \theta = 1/2$$

Squaring both sides, we get  $1 + \sin(2\theta) = 1/4$

$$\Rightarrow \sin(2\theta) = -3/4$$

50. (d)  $\therefore 6\tan^2 x - 2\cos^2 x = \cos 2x$

$$\Rightarrow 6 \left( \frac{1 - \cos 2x}{1 + \cos 2x} \right) - (1 + \cos 2x) = \cos 2x$$

$$\Rightarrow 6 - 6\cos 2x - (1 + \cos^2 2x + 2\cos 2x) = \cos 2x + \cos^2 2x$$

$$\Rightarrow 2\cos^2 x + 9\cos 2x - 5 = 0$$

$$\Rightarrow \cos 2x = \frac{-9 \pm \sqrt{81 + 40}}{4} = \frac{-9 \pm 11}{4}$$

$$\Rightarrow \cos 2x = 1/2 \text{ or } -5 \text{ but } \cos 2x \neq -5$$

$$\Rightarrow \cos 2x = 1/2$$

**SECTION-IV (MORE THAN ONE ARE CORRECT ANSWERS)**

1. (b, c)  $\frac{\sqrt{3}-1}{\sin x} + \frac{\sqrt{3}+1}{\cos x} = 4\sqrt{2}$   
 $(\sqrt{3}-1)\cos x + (\sqrt{3}+1)\sin x = 4\sqrt{2}\sin x \cos x$   
 $\Rightarrow \left(\frac{\sqrt{3}-1}{2\sqrt{2}}\right)\cos x + \frac{\sqrt{3}+1}{2\sqrt{2}}\sin x = \sin 2x$   
 $\Rightarrow \sin\left(\frac{\pi}{3}-\frac{\pi}{4}\right)\cos x + \cos\left(\frac{\pi}{3}-\frac{\pi}{4}\right)\sin x = \sin 2x$   
 $\Rightarrow \sin 15^\circ \cos x + \cos 15^\circ \sin x = \sin 2x$   
 $\Rightarrow \sin(x+15^\circ) = \sin 2x$   
 $\Rightarrow x+15^\circ = n\pi + (-1)^n 2x$   
 $\Rightarrow \begin{cases} \text{if } n=0 \Rightarrow x=15^\circ \text{ i.e. } \frac{\pi}{12} \\ \text{if } n=1 \Rightarrow x=\frac{11\pi}{36} \\ \text{if } n \geq 2 \text{ or } \leq 0 \text{ then } x \notin \left(0, \frac{\pi}{2}\right) \end{cases}$

2. (a, c)  $\because \sin x + \cos x = \sqrt{2}$  for  $x \in [0, \pi]$   
 L.H.S.  $\in [-\sqrt{2}, \sqrt{2}]$  where as R.H.S.  $\in [\sqrt{2}, \infty)$  thus equality holds iff L.H.S. = R.H.S. =  $\sqrt{2}$

i.e.,  $\sin x + \cos x = \sqrt{2}$  &  $+- =$

$\Rightarrow \cos(x - \pi/4) = 1$  &  $y = 1$   
 $\Rightarrow x - \pi/4 = 2n\pi$  &  $y = 1$   
 $\Rightarrow x = 2n\pi + \pi/4$  &  $y = 1$

$\Rightarrow \begin{cases} x = \frac{\pi}{4} & \& y = 1 \\ \text{or} \\ x = \frac{9\pi}{4} & \& y = 1 \end{cases}$

3. (a, b, c, d) Given  $\sin^2 x - a \sin x + b = 0$  has only one solution in  $(0, \pi]$

Let  $\sin x = t \in [0, 1]$   
 $t^2 - at + b = 0$  has both roots equal to else for each  $t \in [0, 1]$  there will be two values of  $x \in [0, \pi]$  except when  $t = 1$

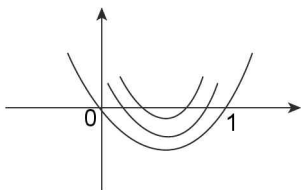

$\Rightarrow 1 - a + b = 0$   
 $\Rightarrow a = b + 1$  ... (i)

Also both roots to be 1  
 $D = a^2 - 4b = 0$  ... (ii)

$\Rightarrow b^2 + 2b + 1 - 4b = 0 \Rightarrow b = 1$  and thus  $a = 2$

4. (a, b, c)  $|x^2 - 1 + \sin x| = |x^2 - 1| + |\sin x|$   
 $\Rightarrow (x^2 - 1)\sin x \geq 0 \Rightarrow (x - 1)(x + 1)\sin x \geq 0$   
 $\Rightarrow \begin{cases} (x-1)(x+1) \geq 0 \& \sin x \geq 0 \\ \text{or} \\ (x-1)(x+1) \leq 0 \& \sin x \leq 0 \end{cases}$

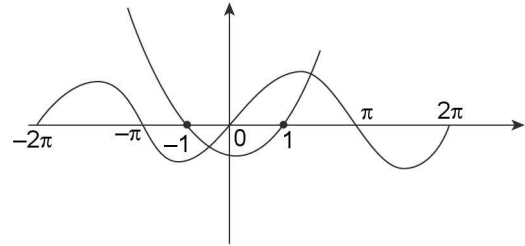

$\Rightarrow x \in [1, \pi]$  or  $[-2\pi, -\pi]$  or  $\{2\pi\}$  or  $x \in [-1, 0]$   
 Thus solution may lie internal  $x \in (2, \pi)$  or  $[-2\pi, -\pi]$  or  $[-1, -1/2]$

5. (a, c, d)  $y = \cos x$  &  $y = \sin 3x$  where  $x \in [-\pi/2, \pi/2]$  for point of intersection

$\Rightarrow \cos x = \sin 3x \Rightarrow \cos x = \cos\left(\frac{\pi}{2} - 3x\right)$

$\Rightarrow x = 2n\pi \pm \left(\frac{\pi}{2} - 3x\right) \Rightarrow \begin{cases} 4x = 2n\pi + \frac{\pi}{2} \\ \text{or} \\ 2x = -2n\pi + \frac{\pi}{2} \end{cases}$

$\Rightarrow \begin{cases} x = \frac{n\pi}{2} + \frac{\pi}{8} \\ \text{or} \\ x = -n\pi + \frac{\pi}{4} \end{cases}$  but as  $x \in \left[-\frac{\pi}{2}, \frac{\pi}{2}\right]$

$\Rightarrow x = \frac{\pi}{8}, \frac{-3\pi}{8}, \frac{\pi}{4}$

$\Rightarrow y = \cos \frac{\pi}{8}; \cos \frac{-3\pi}{8}, \cos \frac{\pi}{4}$  respectively

$\Rightarrow$  Points of intersections are

$\left(\frac{\pi}{8}, \frac{\sqrt{2+\sqrt{2}}}{2}\right); \left(\frac{-3\pi}{8}, \frac{\sqrt{2-\sqrt{2}}}{2}\right)$  and  $\left(\frac{\pi}{4}, \frac{1}{\sqrt{2}}\right)$

6. (a, b, c)  $4\sin x + 2\cos x = 2 + 3\tan x$

Let  $\tan \frac{x}{2} = t$

$\Rightarrow \frac{8t}{1+t^2} + \frac{2-2t^2}{1+t^2} = 2 + \frac{6t}{1+t^2}$

$\Rightarrow 4 + 4 - 14t^3 - 4t^2 + 2t = 0$

$\Rightarrow 2t(2 + 3 - 7t^2 - 2t + 1) = 0$

Clearly one selection is  $t = 0$

$\Rightarrow \tan x/2 = 0 \Rightarrow x/2 = n\pi$

$\Rightarrow x = 2n\pi$

$\Rightarrow$  option (a) is correct

Further as it is difficult to factorize the cubic  $2t^3 - 7t^2 - 2t + 1$ , as we are to guess a value of  $t$  satisfying the equation  $2t^3 - 7t^2 - 2t + 1 = 0$ , as it may be irrational. So let us check by given other options.

In option (b) we have  $x = n\pi + (-1)^n \frac{\pi}{6}$ . It is the general

solution for  $\sin x = \sin \frac{\pi}{6} = \frac{1}{2}$

∴ Substituting  $\sin x = 1/2$ ,  $\cos = \frac{\sqrt{3}}{2}$ ,  $\tan x = 1/\sqrt{3}$

We have,  $4\left(\frac{1}{2}\right) + 2\left(\frac{\sqrt{3}}{2}\right) = 2 + 3\left(\frac{1}{\sqrt{3}}\right)$  i.e.,  $2 + \sqrt{3} = 2 + \sqrt{3}$  which is true

∴ (b) is correct option

In option (c)

we have  $x = 2n\pi - \tan^{-1}(4/3)$

⇒  $\tan x = -4/3$ ;  $\sec x = 5/3$  ⇒  $\cos x = 3/5$  ⇒  $\sin x = -4/5$

Substituting in given equation

$4\left(-\frac{4}{5}\right) + 2\left(\frac{3}{5}\right) = 2 + 3\left(-\frac{4}{3}\right) \Rightarrow -2 = -2$

⇒ (c) is also correct

In option (d)

We have,  $x = 2n\pi + \tan^{-1}(4/3)$

⇒  $\tan x = 4/3$ ;  $\sin x = 4/5$ ,  $\cos x = 3/5$

Substituting in given equation

$4\left(\frac{4}{5}\right) + 2\left(\frac{3}{5}\right) = 2 + 3\left(\frac{4}{3}\right) \Rightarrow \frac{22}{5} = 6$

Which is false ⇒ (d) is incorrect

7. (a, b, c, d) ∴  $2^{|\sin x|} = 4^{|\cos x|}$ ;  $x \in [0, 2\pi]$

⇒  $|\sin x| = 2 |\cos x| \Rightarrow |\tan x| = 2$

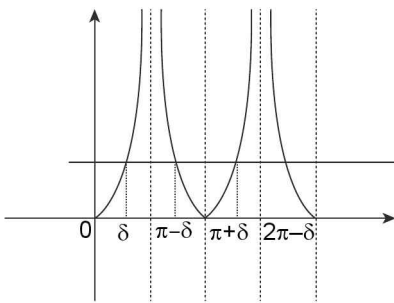

⇒ Clearly from the diagram roots  $\delta, \gamma, \beta, \alpha$  in increasing order are such that

$\gamma = \pi - \delta$

$\beta = \pi + \delta$

$\alpha = 2\pi - \delta$

Thus  $\beta + \gamma = 2\pi$  &  $\gamma + \delta = \pi$

$\alpha + \beta = 3\pi$  &  $\alpha - \gamma = \pi$

8. (a, c) Given  $(1 - \tan^2\theta) \sec^2\theta + 2\tan^2\theta = 0$ ;  $\theta \in \left(-\frac{\pi}{2}, \frac{\pi}{2}\right)$

has  $\theta_1, \theta_2, \theta_3, \dots, \theta_n$  are solution

⇒  $1 - \tan^4\theta + 2 \tan^2\theta = 0 \Rightarrow \tan^4\theta - 2\tan^2\theta - 1 = 0$

⇒  $\tan^2\theta = \frac{2 \pm \sqrt{8}}{2}$

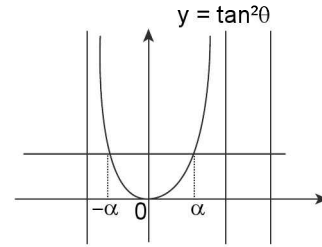

⇒  $\tan^2\theta = 1 \pm \sqrt{2}$

⇒  $\tan^2\theta = 1 + \sqrt{2}$  as  $1 - \sqrt{2}$  is negative quantity

⇒  $\theta = \alpha, -\alpha$  are two real solutions

⇒  $\theta_1 = \alpha, \theta_2 = -\alpha$  only two solutions thus  $n = 2$

⇒  $\theta_1 + \theta_2 = 0$

9. (b, d) Let  $\sin\left(x - \frac{\pi}{3}\right) = t \leq 1$ , then

⇒  $2t^2 - 5t + 2 > 0 \Rightarrow 2t^2 - 4t - t + 2 > 0$

⇒  $2t(t-2) - (t-2) > 0$

⇒  $(2t-1)(t-2) > 0 \quad \therefore t \leq 1$

Therefore  $t < 1/2$

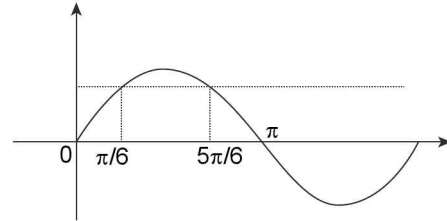

Clearly,  $\left(x - \frac{\pi}{3}\right) \in \left[-\pi, \frac{\pi}{6}\right) \cup \left(\frac{5\pi}{6}, \pi\right]$

⇒  $x \in \left[-\frac{2\pi}{3}, \frac{\pi}{2}\right) \cup \left(\frac{7\pi}{6}, \frac{4\pi}{3}\right]$

In particular, the inequation is satisfied in  $\left(-\frac{2\pi}{3}, \frac{\pi}{2}\right)$  and

hence in  $\left(2n\pi - \frac{2\pi}{3}, 2n\pi + \frac{\pi}{2}\right)$

i.e., in  $\left(-\frac{2\pi}{3}, \frac{\pi}{2}\right)$  and  $\left(\frac{2\pi}{3}(3n-1), (4n+1)\frac{\pi}{2}\right)$

10. (a, c)  $\sin^6 x + \cos^6 x = \lambda^2$  has real solution

⇒  $\lambda^2 \in \text{range of } \sin^6 x + \cos^6 x$

∴  $\sin^6 x + \cos^6 x = (\sin^2 x + \cos^2 x)(\sin^4 x + \cos^4 x - \sin^2 x \cos^2 x) = (\sin^2 x + \cos^2 x)^2 - 3\sin^2 x \cos^2 x = 1 - 3/4 \sin^2 2x$

⇒  $\lambda^2 \in \left[\frac{1}{4}, 1\right] \Rightarrow \lambda \in \left[-1, \frac{1}{2}\right] \cup \left[\frac{1}{2}, 1\right]$

11. (a, b, c) Consider equation  $\sin x = [1 - \sin x] + [1 - \cos x]$

⇒  $\sin x = 2 + [-\sin x] + [-\cos x] \dots (i)$



**2.100** > Trigonometry

∴ L.H.S. ∈ [-1, 1] & R.H.S. ∈ [0, 4]  
 But sinx is an integer ⇒ sinx = 0 or 1  
 Case (i): if sinx = 0, then x = 2nπ the equation become;  
 0 = 2 + 0 - 1 ⇒ no solution  
 Or  
 x = (2n + 1)π the equation ; 0 = 2 + 0 + 1 ⇒ no solution  
 Case (ii) : If sinx = 1, then cosx = 0  
 ⇒ 1 = 2 + 1 + 0 ⇒ 1 = 1  
 ⇒ x = 2nπ +  $\frac{\pi}{2}$ ; n ∈ ℤ  
 ⇒ x =  $\frac{\pi}{2} \in (0, \pi); \left(\frac{\pi}{6}, \frac{2\pi}{3}\right), \left(\frac{\pi}{3}, \frac{5\pi}{6}\right)$

**12. (b, c)** sin<sup>2</sup>x + sinx - a = 0 ; x ∈ [0, 2π)

$$\Rightarrow \sin x = \frac{-1 \pm \sqrt{1+4a}}{2} \in [-1, 1]$$

$$\Rightarrow -2 \leq -1 \pm \sqrt{1+4a} \leq 2$$

$$\Rightarrow -1 \leq \pm \sqrt{1+4a} \leq 3 \Rightarrow 0 \leq 1 + 4a \leq 9$$

$$\Rightarrow a \in \left[-\frac{1}{4}, 2\right]$$

Therefore for a = -1/4 we get both values of sinx equal thus two values of x as a roof

For a ∈  $\left(-\frac{1}{4}, 0\right)$ ; D > 0

⇒ Two distinct values of sinx these 4 distinct values of x.

**13. (a, b, c)** f(θ) = 4sinθ + 3cosθ ∈ [-5, 5]

⇒ if k > 5 equation has no solution & if |k| < 5 i.e., k ∈ (-5, 5)

We get two distinct values of θ satisfying equation as sine & cosine function attain all its possible values ∈ (-1, 1) exactly twice in one period

Also 4sinθ + 3cosθ = k has exactly one solution if k = ± 5

**14. (a, d)** y = sinx - cos<sup>2</sup>x - 1

$$\Rightarrow y = \sin x - 2 + \sin^2 x \Rightarrow y = \left(\sin x + \frac{1}{2}\right)^2 - \frac{9}{4}$$

Clearly y<sub>min</sub> = -9/4 when sinx + 1/2 = 0

$$\Rightarrow \sin x = -1/2 = \sin(-\pi/6)$$

$$\Rightarrow x = n\pi + (-1)^n (-\pi/6)$$

$$\Rightarrow x = n\pi - (-1)^n \frac{\pi}{6} \text{ or } n\pi + (-1)^{n+1} \frac{\pi}{6}$$

**15. (b, d)** sin(x - y) = cos(x + y) = 1/2

$$\Rightarrow x - y = n\pi + (-1)^n \pi/6 ; x - y \in [-\pi, \pi] \& x + y = 2m\pi \pm \pi/3 ; x + y \in [0, 2\pi]$$

$$\Rightarrow \begin{cases} x - y = \frac{\pi}{6}, \frac{5\pi}{6} \\ x + y = \frac{\pi}{3}, \frac{5\pi}{3} \end{cases}$$

Case (i): x - y =  $\frac{\pi}{6}$  & x + y =  $\frac{\pi}{3}$

$$\Rightarrow x = \frac{\pi}{4}, y = \frac{\pi}{12}$$

Case (ii): x - y =  $\frac{\pi}{6}$  & x + y =  $\frac{5\pi}{3}$

$$\Rightarrow x = \frac{11\pi}{12}, y = 3\pi/4$$

**16. (a, c)** Consider the equation cosx.cos6x = -1

$$\Rightarrow \cos 6x = -\sec x$$

L.H.S. ∈ [-1, 1] & R.H.S. ∈ (-∞, -1] ∪ [1, ∞)

$$\text{Equality possible iff } \begin{cases} \cos 6x = 1 \& \sec x = -1 \\ \text{or} \\ \cos 6x = -1 \& \sec x = 1 \end{cases}$$

$$\Rightarrow x = (2n + 1)\pi \text{ or } x = (2n - 1)\pi$$

**17. (b, d)** sinA = sin B ⇒  $\frac{\sin A}{\sin B} = 1$  ... (i)

Similarly  $\frac{\cos A}{\cos B} = 1$  ... (ii)

Equation (i) - equation (ii), we get  $\frac{\sin A}{\sin B} - \frac{\cos A}{\cos B} = 0$

$$\Rightarrow \sin A \cos B - \cos A \sin B = 0$$

$$\Rightarrow \sin(A - B) = 0$$

$$\Rightarrow A - B = \text{a multiple of } n\pi \text{ and hence of } 2n\pi,$$

$$\therefore A = 2n\pi + B$$

**18. (a, b)** Minimum value of a<sup>2</sup> - 4a + 6 =  $\frac{-[16 - 24]}{4 \times 1} = 2$ ;

$$[-D/4a]$$

∴ Given equation becomes sinx + cosx = 1

$$\therefore \sqrt{2} \left[ \frac{1}{\sqrt{2}} \sin x + \frac{1}{\sqrt{2}} \cos x \right] = 1$$

$$\Rightarrow \sin \left( x + \frac{\pi}{4} \right) = \frac{1}{\sqrt{2}}$$

$$\therefore x + \frac{\pi}{4} = n\pi + (-1)^n \cdot \frac{\pi}{4}$$

$$\therefore x + n\pi + (-1)^n \frac{\pi}{4} - \frac{\pi}{4}$$

(i) If n is even

$$\therefore x = \text{even integer } \pi$$

$$x = 2n\pi$$

(ii) If n is odd

$$\therefore x = (\text{odd integer}) \cdot \pi - \pi/2$$

$$= (\text{even integer})\pi + \pi/2$$

$$\therefore x = 2n\pi + \frac{\pi}{2}$$

**SECTION-V (ASSERTION AND REASON TYPE ANSWERS)**

**1. (a)** A: By the question 2sinx + cosy = 2

$$\Rightarrow \cos y = 2 - 2\sin x = 2(1 - \sin x)$$

$$\text{But } -1 \leq \cos y \leq 1 \Rightarrow -1 \leq 2(1 - \sin x) \leq 1$$

$$\begin{aligned} \Rightarrow -1/2 &\leq (1 - \sin x) \leq 1/2 \\ \Rightarrow 1/2 &\leq \sin x \leq 3/2 \\ \Rightarrow 1/2 &\leq \sin x \leq 1 \quad (\because \sin x \text{ is never greater than one}) \end{aligned}$$

$$\text{Let } \sin x = t \left( t = \left[ \frac{1}{2}, 1 \right] \right)$$

$$\begin{aligned} \Rightarrow \sin x &= \sin^{-1}(t) \Rightarrow x = n\pi + (-1)^n \cdot \sin^{-1}(t) \\ \text{Also } \cos y &= 2(1 - \sin x) = 2(1 - t) \\ \Rightarrow \cos y &= \cos^{-1} 2(1 - t) \\ \Rightarrow y &= 2n\pi \pm \cos^{-1} 2(1 - t), \text{ hence assertion is correct} \\ \text{R: Simply } \cos y &= 2(1 - \sin x), \text{ but } -1 \leq \cos y \leq 1 \end{aligned}$$

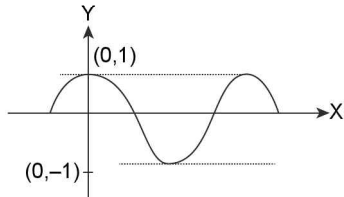

$$\Rightarrow -1/2 \leq 1 - \sin x \leq 1/2 \Rightarrow 1/2 \leq \sin x \leq 1 \text{ which is true}$$

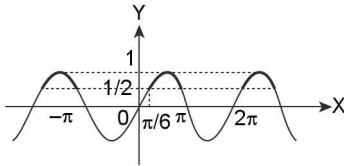

Hence reason is correct and also is the correct explanation of assertion.

2. (a) A:  $f(x) = \frac{1}{\sqrt{\{\sin x\} + \{\sin(\pi + x)\}}}$ ;  $\sin(\pi + x) = -\sin x$

$$\Rightarrow \{\sin(\pi + x)\} = \{-\sin x\}$$

$$f(x) \text{ reduces to } f(x) = \frac{1}{\sqrt{\{\sin x\} + \{-\sin x\}}}$$

$$\{\sin x\} = \sin x \text{ (when } \sin x \text{ is not an integer)}$$

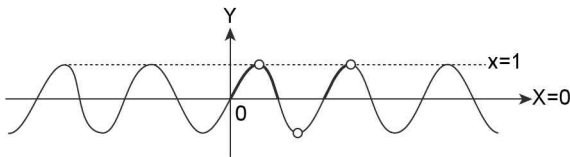

$\sin x$  is an integer only at +1 or -1, which makes  $\{\sin x\} = 0$

The domain of function is when  $\{\sin x\} + \{-\sin x\} > 0$ . Obviously it is never negative, thus we have to exclude the possibilities  $\{\sin x\} + \{-\sin x\} = 0$

$$\Rightarrow \begin{cases} \{\sin x\} = \sin x & \text{if } \left( x \neq (2n+1)\frac{\pi}{2} \right) \\ \{\sin x\} = 0 & \text{if } \left( x = (2n+1)\frac{\pi}{2} \right) \end{cases} \dots (i)$$

$$\Rightarrow \begin{cases} \{-\sin x\} = 1 - \{\sin x\}; \sin x \notin 1 & \left( x \neq (2n+1)\frac{\pi}{2} \right) \\ = 0; \sin x \in 1 & \left( x = (2n+1)\frac{\pi}{2} \right) \end{cases} \dots (ii)$$

$$\begin{aligned} \Rightarrow \{\sin x\} + \{-\sin x\} &= 1 \text{ } \sin x \text{ not an integer} \\ &= 0 \text{ } \sin x \text{ is an integer} \end{aligned}$$

Domain =  $x \neq (2n+1)\pi/2$ , assertion is correct.

$$\text{R: } \{\sin x\} + \{-\sin x\} = \begin{cases} 0; & \sin x \text{ is an integer} \\ 1; & \sin x \text{ is not integer} \end{cases}$$

$\Rightarrow$  Reason is correct already explained in assertion.

3. (c) A:  $\sin x = [1 + \sin x] + [1 - \cos x]$

$$\Rightarrow \sin x - [1 + \sin x] = [1 - \cos x]$$

$$\Rightarrow 1 + \sin x - [1 + \sin x] = [1 - \cos x] + 1$$

$$\Rightarrow \{1 + \sin x\} = [1 - \cos x] + 1; -1 \leq -\cos x \leq 1; 0 \leq 1 - \cos x \leq 2$$

Which is never possible as  $0 \leq \{1 + \sin x\} < 1$

$$\text{R: } x - 1 [x] \Rightarrow x.[x] < 1$$

$$\Rightarrow \{x\} < 1 \text{ is true but } [x] \neq x \forall x \in \mathbb{R}$$

$\therefore$  Reason is incorrect.

4. (a)  $\sin x = -1/2$

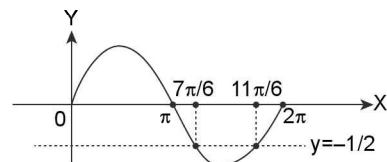

$$\alpha = -\frac{7\pi}{6}; \beta = \frac{11\pi}{6}; \cos x = \frac{-\sqrt{3}}{2}$$

$$\Rightarrow \alpha = \frac{7\pi}{6}; \gamma = \frac{5\pi}{6} \Rightarrow \beta - \gamma = \frac{11\pi}{6} - \frac{5\pi}{6} = \pi$$

$$\text{and } \alpha + \beta = \frac{7\pi}{6} + \frac{11\pi}{6} = 3\pi$$

Hence assertion is correct.

**Reason:**  $\sin x$  is positive in 2<sup>nd</sup> quadrant, 2<sup>nd</sup> quadrant means  $\pi/2 \leq x \leq \pi$ , which is true by the graph

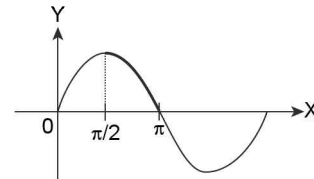

$\cos x$  is positive in quadrant 4, quadrant 4 means  $\frac{3\pi}{2} \leq x \leq 2\pi$ , Which is true by the graph.

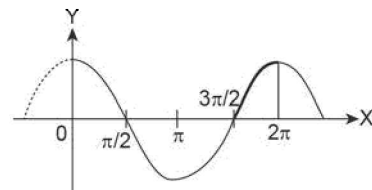

Reason is correct moreover it also explains correct the assertion.

5. (d)  $\sin = -\frac{1}{2}$  in  $[0, 2\pi]$

$$\text{By question 4, } \alpha = \frac{7\pi}{6}, \beta = \frac{5\pi}{6}, \tan x = \frac{1}{\sqrt{3}} \text{ in } [0, 2\pi]$$

2.102 > Trigonometry

$$\Rightarrow \alpha = \frac{7\pi}{6}, \gamma = \frac{\pi}{6} \Rightarrow 2\beta = \frac{5\pi}{3}, 3\gamma = \frac{\pi}{2}$$

$$\Rightarrow 2\beta + 3\gamma = \frac{5\pi}{3} + \frac{\pi}{2} = \frac{13\pi}{6} \neq \frac{7\pi}{3} (2\alpha)$$

∴ Assertion is not correct

**R:** 1<sup>st</sup> quadrant  $\Rightarrow 0 \leq x \leq \frac{\pi}{2}$

2<sup>nd</sup> quadrant  $\Rightarrow \frac{\pi}{2} \leq x < \pi$

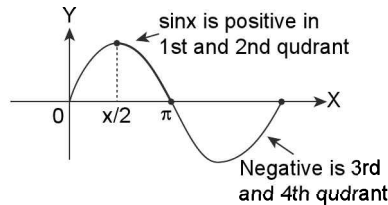

tan x in first quadrant

$$\sin x > 0; \cos x > 0 \Rightarrow \tan x > 0$$

In 4th quadrant

$$\sin x < 0; \cos x > 0 \Rightarrow \tan x < 0$$

In 2nd quadrant

$$\sin x > 0; \cos x < 0 \Rightarrow \tan x < 0$$

In 3rd quadrant

$$\sin x < 0; \cos x < 0 \Rightarrow \tan x > 0$$

Hence reason is correct but assertion is incorrect

6. (d)  $|\sin x| + |\cos x| = \frac{1}{2}$

In first quadrant say  $|\sin x| + |\cos x| = \sin x + \cos x = \sqrt{2} \sin\left(x + \frac{\pi}{4}\right)$

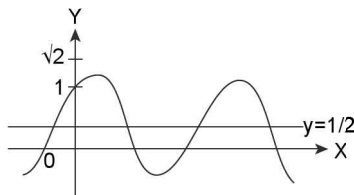

Thus assertion is incorrect as it has solution in first quadrant.

**R:**  $|\sin x| + |\cos x|$

In first quadrant:  $\sin x + \cos x = \sqrt{2} \sin\left(x + \frac{\pi}{4}\right)$

In second quadrant:  $\sin x - \cos x = \sqrt{2} \sin\left(x - \frac{\pi}{4}\right)$

In third quadrant:  $-(\sin x + \cos x) = -\sqrt{2} \sin\left(x + \frac{\pi}{4}\right)$

In fourth quadrant:  $\cos x - \sin x = \sqrt{2} \cos\left(x + \frac{\pi}{4}\right)$

Thus in all cases maximum value of  $|\sin x| + |\cos x| \leq \sqrt{2}$

Hence reason is correct

7. (d) **A:** By A.M  $\geq$  G.M

$$\frac{2^{\sin x} + 2^{\cos x}}{2} \geq \sqrt{2^{\sin x + \cos x}}$$

$$\Rightarrow \text{Maximum value of } \sin x + \cos x = \sqrt{2}$$

$$\Rightarrow \text{Minimum value of } \sin x + \cos x = -\sqrt{2}$$

$$\Rightarrow 2^{\sin x} + 2^{\cos x} \geq 2.2^{\frac{\sqrt{2}}{2}} \Rightarrow 2^{\sin x} + 2^{\cos x} \geq 2^{1-\frac{1}{\sqrt{2}}}$$

Equality holds at ( $2^{\sin x} = 2^{\cos x}$ )

$$\Rightarrow \tan x = 1$$

$$\Rightarrow x = n\pi + \frac{\pi}{4}. \text{ Hence assertion is incorrect}$$

**R:** A.M =  $a + \frac{b}{2}$ ; G.M =  $(ab)^{1/2}$

$$a + b \geq 2\sqrt{ab}$$

$$\Rightarrow a + b - 2\sqrt{ab} \geq 0$$

$$\Rightarrow (\sqrt{a} - \sqrt{b})^2 \geq 0; \text{ Which is true.}$$

Hence reason is correct.

8. (b) **A:**  $\cos^2\left(\frac{px}{2}\right) + \cos^2\left(\frac{qx}{2}\right) = 1$

$$\Rightarrow \cos^2\left(\frac{p(x)}{2}\right) = \sin^2\left(\frac{qx}{2}\right)$$

$$\Rightarrow \cos^2\left(\frac{px}{2}\right) = \cos^2\left(\frac{\pi}{2} - \frac{qx}{2}\right)$$

$$\Rightarrow \frac{px}{2} = n\pi \pm \left(\frac{\pi}{2} - \frac{qx}{2}\right)$$

$$\Rightarrow x = \frac{2\pi}{p+q} \left(n \pm \frac{1}{2}\right) \text{ or } x = \frac{2\pi}{p-q} \left(n \pm \frac{1}{2}\right)$$

Which gives values as  $\frac{\pi}{p+q}, \frac{3\pi}{p+q}, \frac{5\pi}{p+q}$

$$\left(\text{common diff} = \frac{2\pi}{p+q}\right)$$

$$\text{Or } \frac{\pi}{p-q}, \frac{3\pi}{p+q}, \frac{5\pi}{p-q} \left(\text{common diff} = \frac{2\pi}{p-q}\right)$$

Assertion is correct

**R:**  $\cos\phi + \cos\theta = 2$

$$\Rightarrow \cos\phi = 2 - \cos\theta \Rightarrow -1 \leq 2 - \cos\theta \leq 1$$

$$\Rightarrow -1 \leq -\cos\theta \leq -1$$

$$\Rightarrow \cos\theta = 1 \text{ and } \cos\phi = 1$$

Hence both reason and assertion are correct but reason is not a correct explanation of assertion.

9. (a) **A:**  $\cot\left(\frac{\pi}{3} \cos 2\pi x\right) = \sqrt{3}$

$$\Rightarrow \tan\left(\frac{\pi}{3} \cos 2\pi x\right) = \tan\left(\frac{\pi}{6}\right)$$

$$\Rightarrow \frac{\pi}{3} \cos 2\pi x = n\pi + \frac{\pi}{6}$$

$$\Rightarrow \cos 2\pi x = 3\left(n + \frac{1}{6}\right) (n \in \mathbb{Z}) \text{ but } -1 \leq \cos 2\pi x \leq 1$$

$$\Rightarrow -1 \leq 3\left(n + \frac{1}{6}\right) \leq 1 \Rightarrow -\frac{1}{2} \leq n \leq \frac{1}{6}$$

$$\Rightarrow n = 0.$$

$$\text{Thus } \cos 2\pi x = \frac{1}{2} = \cos\left(\frac{\pi}{3}\right)$$

$$\Rightarrow 2\pi x = 2\pi n \pm \frac{\pi}{3} \Rightarrow x = \left(n \pm \frac{1}{6}\right) n \in \mathbb{Z}$$

Assertion is correct

$$\mathbf{R}: -1 \leq \cos x \leq 1$$

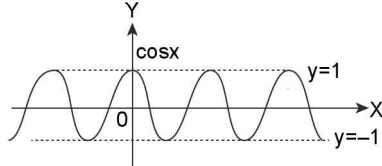

Reason is correct

$$10. \text{ (a) } \mathbf{A}: \sin^3 x + \cos^7 x = 1$$

Which can be written as  $\cos^7 x - \cos^2 x = \sin^2 x - \sin^3 x$

$$\Rightarrow \cos^2 x (\cos^5 x - 1) = \sin^2 x (1 - \sin x)$$

Which can hold only when  $\sin x = 0$ ,  $\cos x = 1$  or  $\cos x = 0$ ,  $\sin x = 1$ , i.e.,  $x = 0$ ,  $x = \frac{\pi}{2}, 2\pi$

Hence number of solutions = 3 in  $[0, 2\pi]$

$\mathbf{R}: \cos^n x \leq \cos^2 x$  is true when  $\cos^2 x - \cos^n x \geq 0$  is true when  $\cos^2 x (1 - \cos^{n-2} x) \geq 0$  is true as maximum value of  $\cos^{n-2} x$  is also 1. ( $n \geq 2$ )  $n \in \mathbb{N}$

Similarly,  $\sin^n x \leq \sin^2 x$  is true when  $\sin^2 x - \sin^n x \geq 0$  is true when  $\sin^2 x (1 - \sin^{n-2} x) \geq 0$  which is true as maximum value of  $\sin^{n-2} x$  is 1. Reason is correct and also explains assertions

$$11. \text{ (a) } \mathbf{A}: \sin x + \cos x = \sqrt{y + \frac{1}{y}}; x \in [0, \pi]$$

$$y + \frac{1}{9} \geq 2 \Rightarrow \sqrt{y + \frac{1}{y}} \geq \sqrt{2}$$

L.H.S.  $\sin x + \cos x = \sqrt{2} \cos\left(x - \frac{\pi}{4}\right)$  which have maximum =  $\sqrt{2}$

$$\text{Hence equality holds at } \sqrt{y + \frac{1}{y}} = \sqrt{2}$$

$$\Rightarrow y = 1$$

$$\text{And } \cos\left(\frac{x - \pi}{4}\right) = 1 \Rightarrow x = \frac{\pi}{4}$$

Assertion is correct

$\mathbf{R}: \text{A.M.} \geq \text{G.M.}$  For two positive numbers  $a, b$ ,

$$\frac{a+b}{2} \geq (ab)^{\frac{1}{2}} \Rightarrow a+b-2\sqrt{ab} \geq 0$$

$$\Rightarrow (\sqrt{a} - \sqrt{b})^2 \geq 0 \text{ which is true. Reason is correct}$$

$$12. \text{ (d) } \mathbf{A}: \tan\left(\frac{\pi}{2} - \sin \theta\right) = \cot\left(\frac{\pi}{2} - \cos \theta\right) = \tan\left(\frac{\pi}{2} - \frac{\pi}{2} - \cos \theta\right)$$

$$\Rightarrow \frac{\pi}{2} - \sin \theta = n\pi + \frac{\pi}{2} - \frac{\pi}{2} \cos \theta$$

$$\Rightarrow \sin \theta + \cos \theta = 2n + 1, n \in \mathbb{Z}$$

$$\text{Also } \sin \theta + \cos \theta = \sqrt{2} \cos\left(\theta - \frac{\pi}{4}\right)$$

$$\Rightarrow -\sqrt{2} \leq \sin \theta + \cos \theta \leq \sqrt{2}$$

$$\Rightarrow \sin \theta + \cos \theta = \pm 1$$

Assertion is correct

$$\mathbf{R}: \sin \theta + \cos \theta = \sqrt{2} \left( \frac{1}{\sqrt{2}} \sin \theta + \frac{1}{\sqrt{2}} \cos \theta \right)$$

$$= \sqrt{2} \sin\left(\theta + \frac{\pi}{4}\right)$$

$$\text{Now } -1 \leq \sin\left(\theta + \frac{\pi}{4}\right) \leq 1$$

$$\Rightarrow -\sqrt{2} \leq \sqrt{2} \sin\left(\theta + \frac{\pi}{4}\right) \leq \sqrt{2}$$

$$\Rightarrow -\sqrt{2} \leq \sin \theta + \cos \theta \leq \sqrt{2}$$

Reason is correct

### SECTION-VI (MATCH THE COLUMN TYPE ANSWERS)

#### Column -1

$$1. \text{ (i) } \rightarrow \text{(a, c)} \text{ (ii) } \rightarrow \text{(c, d)} \text{ (iii) } \rightarrow \text{(a)} \text{ (iv) } \rightarrow \text{(b)}$$

$$\text{(i) } (1 - \tan \theta)(1 + \tan \theta) \sec^2 \theta + 2 \tan^2 \theta = 0$$

$$\Rightarrow (1 - \tan^2 \theta)(1 + \tan^2 \theta) + 2 \tan^2 \theta = 0$$

$$\Rightarrow (1 - \tan^4 \theta) + 2 \tan^2 \theta = 0$$

$$\Rightarrow \tan^4 \theta - 2 \tan^2 \theta - 1 = 0$$

$$\Rightarrow (\tan^2 \theta - 1)^2 - 2 = 0$$

$$\Rightarrow \tan^2 \theta - 1 = \sqrt{2} \text{ or } \tan^2 \theta - 1 = -\sqrt{2}$$

$$\Rightarrow \tan^2 \theta = \sqrt{2} + 1 \text{ or } -\sqrt{2} + 1 (< 0)$$

$$\Rightarrow \tan^2 \theta = \sqrt{2} + 1 > 1 \text{ and } > \sqrt{3}$$

$$\Rightarrow \theta > \frac{\pi}{4} \text{ as well as } \frac{\pi}{3}$$

$$\therefore \theta \text{ is greater than } \frac{\pi}{4}$$

$$\text{(ii) } \sum_{n=0}^{\infty} \sin^n \theta = 1 + \sin \theta + \sin^2 \theta + \sin^3 \theta + \sin^4 \theta + \dots$$

This looks like an infinite G.P. also  $|\sin \theta| \leq 1$  (but  $\theta \neq \pi/2$ )

For  $|\sin x| < 1$

$$\sum_{n=0}^{\infty} \sin^n \theta = \frac{1}{1 - \sin \theta} = 4 + 2\sqrt{3} \text{ (by the question)}$$

$$\Rightarrow 4 + 2\sqrt{3} - 4\sin \theta - 2\sqrt{3} \sin \theta = 1$$

$$\Rightarrow \sin \theta = \frac{3 + 2\sqrt{3}}{4 + 2\sqrt{3}}$$

On rationalizing

$$\sin \theta = \frac{(3 + 2\sqrt{3})(4 - 2\sqrt{3})}{(4 + 2\sqrt{3})(4 - 2\sqrt{3})} = \frac{12 - 6\sqrt{3} + 8\sqrt{3} - 12}{16 - 12} = \frac{\sqrt{3}}{2}$$

$$\Rightarrow \theta = \frac{\pi}{3}, \frac{2\pi}{3}$$

2.104 > Trigonometry

(iii)  $\sin x \sqrt{8 \cos^2 x} = 1 \Rightarrow 2 \sin x |\cos x| = 1/\sqrt{2}$

If  $\cos x > 0 \Rightarrow \sin 2x = \frac{-1}{\sqrt{2}}$

$\Rightarrow x = \frac{\pi}{8}, \frac{2\pi}{8}, \dots$

If  $\cos x < 0$

$\Rightarrow \sin 2x = \frac{-1}{\sqrt{2}} \Rightarrow x = \frac{5\pi}{8}, \frac{7\pi}{8}, \dots$

Values of  $x$  form an A.P. with common difference

$= \frac{\pi}{8} - \frac{\pi}{8} = \frac{\pi}{4}$

(iv)  $2^{\cos 2x} - 3 \cdot 2^{-\sin^2 x} + 1 = 0$

$\Rightarrow 2^{\cos^2 x} \cdot 2^{-\sin^2 x} - 3 \cdot 2^{-\sin^2 x} + 1 = 0$

$2^{-\sin^2 x} = Y \Rightarrow Y \cdot 2Y - 3Y + 1 = 0$

$\Rightarrow 2Y^2 - 3Y + 1 = 0$

$\Rightarrow 2Y(Y-1) - (Y-1) = 0$

$\Rightarrow Y = 1$  or  $Y = 1/2$

$\Rightarrow 2^{-\sin^2 x} = 1 \Rightarrow \sin^2 x = 0$

$\Rightarrow 2^{-\sin^2 x} = \frac{1}{2} \Rightarrow 2^{1-\sin^2 x} = 1$

$\Rightarrow \sin^2 x = 1 \Rightarrow x = \pi/2$

2. (i) → (b) (ii) → (a) (iii) → (c) (iv) → (d)

(i)  $e^x + e^{-x} = \tan x$

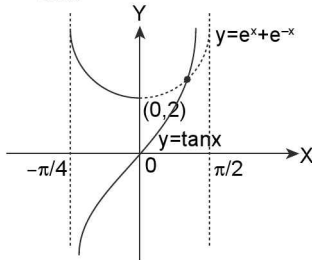

In the range  $x \in \left[0, \frac{\pi}{2}\right)$  the number of solutions as given by the graph is m.

(ii)  $x + y = 2\pi/3$ ;

$\cos x + \cos y = 3/2 \Rightarrow \cos x + \cos\left(\frac{2\pi}{3} - x\right) = \frac{3}{2}$

$\Rightarrow \cos x + \cos\frac{2\pi}{3} \cdot \cos x + \sin\frac{2\pi}{3} \cdot \sin x = \frac{3}{2}$

$\Rightarrow \cos x - \frac{\cos x}{2} + \frac{\sqrt{3} \sin x}{2} = \frac{3}{2}$

$\Rightarrow \cos x + \sqrt{3} \sin x = 3$

$\Rightarrow \frac{1}{2} \left( \frac{1}{2} \cos x + \frac{\sqrt{3}}{2} \sin x \right) = 3$

$\Rightarrow \sin\left(x + \frac{\pi}{6}\right) = 6$ . Which is obviously not possible.

(iii)  $\cos x + 2 \sin x = 1; x \in [0, 2\pi]$

$\Rightarrow \cos x - 1 = -2 \sin x \Rightarrow 1 - \cos x = 2 \sin x$

$\Rightarrow 2 \sin^2 \frac{x}{2} = 2 \sin x$

$\Rightarrow \sin^2 \frac{x}{2} = 2 \cdot \sin \frac{x}{2} \cdot \cos \frac{x}{2}$

$\Rightarrow \sin \frac{x}{2} \left( \sin \frac{x}{2} - 2 \cos \frac{x}{2} \right) = 0$

There are two possible solutions.

$\sin \frac{x}{2} = 0$  or  $\sin \frac{x}{2} = 2 \cos \frac{x}{2}$  (or  $\tan \frac{x}{2} = 2$ ) this will

give are solution

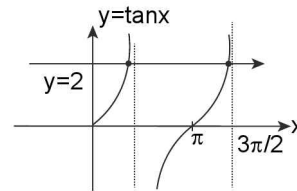

In the range  $x \in (0, 2\pi]$ ;  $x = 2\pi$

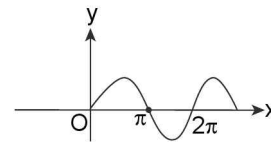

(iv)  $(\sqrt{3} \sin x + \cos x)^{\sqrt{\sqrt{3} \sin 2x - \cos 2x + 2}} = 4$

$= \sqrt{3} \sin 2x - \cos 2x + 2 = 2 - (\cos 2x - \sqrt{3} \sin 2x)$

$= 2 - 2 \left( \frac{1}{2} \cos 2x - \frac{\sqrt{3}}{2} \sin 2x \right)$

$= 2 - 2 \cos \left( \frac{\pi}{3} + 2x \right) = 2 \cdot 2 \sin^2 \left( \frac{\pi}{6} + 2x \right)$

$\Rightarrow \sqrt{\sqrt{3} \sin 2x - \cos 2x + 2} = 2 \left| \sin \left( \frac{\pi}{6} + 2x \right) \right|$

Also  $\sqrt{3} \sin x + \cos x = 2 \left( \frac{\sqrt{3}}{2} \sin x + \frac{1}{2} \cos x \right) = 2 \cdot \sin \left( x + \frac{\pi}{6} \right)$

If  $\sin \left( x + \frac{\pi}{6} \right) = Y$

The expression becomes  $(2Y)^{2Y} = 2^2$ , on comparison  $y = 1$

$\Rightarrow \sin \left( \frac{\pi}{6} + x \right) = 1$ , which has infinite number of solutions.

3. (i) → (a, b) (ii) → (c) (iii) → (a, b, c) (iv) → (d)

(i)  $2 \sin^2 x + \sin^2 2x = 2 = 2 \sin^2 x + 4 \sin^2 x \cdot \cos^2 x = 2 = \sin^2 x + 2 \cos^2 x \cdot \sin^2 x = 1$

$= 2 \cos^2 x \sin^2 x - \cos^2 x = 0 = \cos^2 x (2 \sin^2 x - 1) = 0$

$\Rightarrow \cos^2 x = 0$  or  $\sin^2 x = \frac{1}{2}$

Out of the values in column (II)  $x = \frac{\pi}{4}, \frac{3\pi}{4}$

$$(ii) |\cos x|^{\sin^2 x - \frac{3}{2}\sin x + \frac{1}{2}} = 1$$

$$\begin{aligned} \text{Consider } y &= \sin^2 x - \frac{3}{2}\sin x + \frac{1}{2} \\ &= \frac{1}{2}(2\sin^2 x - 3\sin x + 1) = \frac{1}{2}(\sin x - 1)(2\sin x - 1) \end{aligned}$$

L.H.S. is one if any of following cases

- (i)  $\sin x = 1$                       (ii)  $\sin x = 1/2$   
 (iii)  $|\cos x| = 1$   
 Out of column (II)  $\Rightarrow x = \pi$   
 (iii)  $|\tan x| = \sin 2x$ , by the graph

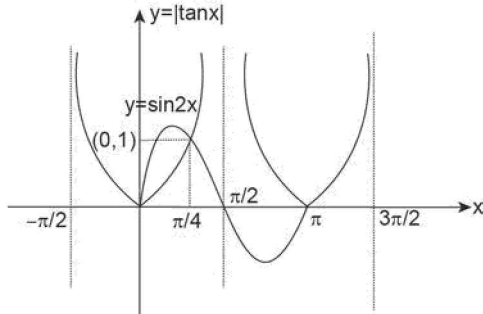

$$x = \frac{\pi}{4}, \frac{3\pi}{4}, \pi$$

$$(iv) \cot x + \tan x = 2\operatorname{cosec} x$$

$$\begin{aligned} \Rightarrow \frac{\cos x}{\sin x} + \frac{\sin x}{\cos x} &= \frac{2}{\sin x} \Rightarrow \frac{1}{\sin x \cos x} = \frac{2}{\sin x} \\ \Rightarrow \sin x &= 2\sin x \cdot \cos x \Rightarrow \sin x(2\cos x - 1) = 0 \\ \Rightarrow \sin x = 0 &\text{ or } \cos x = 1/2 \text{ but } \sin x \neq 0 \\ \text{Out of values in column (II)} \end{aligned}$$

### SECTION-VII (COMPREHENSION TYPE ANSWERS)

$$1. (b) \frac{4}{\sin x} + \frac{1}{1 - \sin x} = a; \text{ it defined for } \sin x \neq 0, 1 - \sin x \neq 0$$

$$\Rightarrow x \neq n\pi, x \neq (4n + 1)\pi/2$$

$$\Rightarrow x \neq n\pi, (4n + 1)\pi/2$$

$$2. (d) \frac{4}{\sin x} + \frac{1}{1 - \sin x} = a$$

$$\Rightarrow \frac{4 - 3\sin x}{\sin x - \sin^2 x} = a$$

$$\Rightarrow a \sin^2 x + \sin x(-3 - a) + 4 = 0$$

$$\text{By the question } 0 < \frac{(3+a) \pm \sqrt{a^2 - 10a + 9}}{2a} < 1$$

$$\Rightarrow 0 < \frac{(3+a) \pm \sqrt{(a-1)(a-9)}}{2a} < 1$$

Hence  $a = 9$  given the required result

$$3. (d) a = 10$$

$$\frac{4}{\sin x} + \frac{1}{1 - \sin x} = a \text{ then,}$$

$$\frac{4}{\sin x} + \frac{1}{1 - \sin x} = 10 = \frac{4 - 3\sin x}{\sin x(1 - \sin x)} = 10$$

$$= 10 \sin^2 x - 13\sin x + 4 = 0$$

$$= 10 \sin^2 x - 8\sin x - 5\sin x + 4 = 0 = 2 \sin x (5\sin x - 4) - (5\sin x - 4) = 0 = (5\sin x - 4)(2\sin x - 1) = 0$$

$$= \sin x = \frac{4}{5} \text{ or } \frac{1}{2}$$

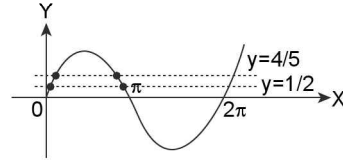

In all 4 solutions

$$\begin{aligned} 4. (d) 1 - \sin 2x &= \cos x - \sin x = 1 - 2\sin x \cdot \cos x = \cos x - \sin x \\ &= \sin^2 x + \cos^2 x - 2\sin x \cdot \cos x = \cos x - \sin x \\ &= (\cos x - \sin x)^2 - (\cos x - \sin x) = 0 = (\cos x - \sin x)(\cos x - \sin x - 1) = 0 \end{aligned}$$

$$\cos x - \sin x = 0 = \sqrt{2} \left( \frac{1}{\sqrt{2}} \cos x - \frac{1}{\sqrt{2}} \sin x \right) = 0$$

$$= \sqrt{2} \cos \left( x + \frac{\pi}{4} \right) = 0$$

$$\Rightarrow x + \frac{\pi}{4} = (2n+1)\frac{\pi}{2} \Rightarrow x = n\pi + \frac{\pi}{4}$$

$$\text{or } \cos x - \sin x - 1 = 0 \Rightarrow \cos x - \sin x = 1$$

$$\Rightarrow \sqrt{2} \left( \frac{1}{\sqrt{2}} \cos x - \frac{1}{\sqrt{2}} \sin x \right) = 1$$

$$\Rightarrow \cos \left( x + \frac{\pi}{4} \right) = \cos \left( \frac{\pi}{4} \right)$$

$$\Rightarrow x + \frac{\pi}{4} = 2n\pi \pm \frac{\pi}{4}$$

$$\Rightarrow x = 2n\pi, 2n\pi + \frac{\pi}{2} \left( 2 \left( n\pi + \frac{\pi}{4} \right) \right)$$

$$\text{Hence overall } x = 2n\pi, \left( n\pi + \frac{\pi}{4} \right), (2n\pi + \pi/2)$$

$$5. (a) \sin x + \cos x = 1 + \sin x \cdot \cos x$$

$$\sin x - \sin x \cdot \cos x + \cos x - 1 = 0 = \sin x(1 - \cos x) - (1 - \cos x) = 0 = (1 - \cos x)(\sin x - 1) = 0$$

$$\cos x = 1 \Rightarrow x = 2n\pi$$

$$\sin x = 1 \Rightarrow x = (4n+1)\frac{\pi}{2} = 2n\pi + \frac{\pi}{2}$$

$$\text{Hence } x = 2n\pi, 2n\pi + \frac{\pi}{2}; n \in \mathbb{Z}$$

$$6. (b) 1 + \sin^3 x + \cos^3 x - 3/2 \sin 2x = 0 \text{ which can be written as } 1 + (\sin x)^3 + (\cos x)^3 - 3\sin x \cdot \cos x = 0$$

$$\text{Comparing this with } a^3 + b^3 + c^3 - 3abc = 0$$

$$\therefore a^3 + b^3 + c^3 - 3abc = (a+b+c)(a^2 + b^2 + c^2 - ab - bc - ca)$$

$$= (a+b+c) \left( \frac{1}{2}(a-b)^2 + \frac{1}{2}(b-c)^2 + \frac{1}{2}(c-a)^2 \right) = 0,$$

$$\text{only if } a + b + c = 0 \text{ or } a = b = c$$

$$\Rightarrow \sin x + \cos x + 1 = 0 \Rightarrow \sin x + \cos x = -1$$

$$\Rightarrow \sqrt{2} \left( \cos \left( x - \frac{\pi}{4} \right) \right) = -1$$

$$\Rightarrow \cos \left( x - \frac{\pi}{4} \right) = -\frac{1}{\sqrt{2}}$$

$$\Rightarrow \cos \left( x - \frac{\pi}{4} \right) = \cos \left( \frac{3\pi}{4} \right)$$

$$\Rightarrow x - \frac{\pi}{4} = 2n\pi \pm \frac{3\pi}{4}$$

$$\Rightarrow x = 2n\pi - \frac{\pi}{2}, 2n\pi + \pi$$

$$\Rightarrow x = (2n + 1)\pi, 2n\pi - \pi/2; n \in \mathbb{Z}$$

7. (a, d)  $\sin x + \cos x - 2\sqrt{2} \sin x \cdot \cos x = 0$

Putting  $\sin x + \cos x = t$

Equation reduces to  $t - \sqrt{2}t^2 + \sqrt{2} = 0$

$$\Rightarrow t = 2, -1/\sqrt{2}$$

Hence  $\sin x + \cos x = \sqrt{2}$

$$\Rightarrow \sin \left( x + \frac{\pi}{4} \right) = 1 \Rightarrow x + \frac{\pi}{4} = (4n + 1)\frac{\pi}{2}$$

$$\Rightarrow x = 2n\pi + \frac{\pi}{4} \text{ or } \sin x + \cos x = -\frac{1}{\sqrt{2}}$$

$$\Rightarrow \sin x \cdot \cos \frac{\pi}{4} + \sin \frac{\pi}{4} \cdot \cos x = -\frac{1}{2}$$

$$\Rightarrow \sin \left( x + \frac{\pi}{4} \right) = -\frac{1}{2}$$

$$\Rightarrow x + \frac{\pi}{4} = n\pi - (-1)^n \frac{\pi}{6}$$

$$\Rightarrow x = n\pi - (-1)^n \frac{\pi}{6} - \frac{\pi}{4}$$

8. (a) Since  $\sin\theta$  and  $\cos\theta$  are minima and maxima respectively

$$\Rightarrow f'(x) = 6x^2 - a^2x - 3 = 6x^2 - 2ax - 3$$

$\sin\theta$  and  $\cos\theta$  must be the roots of this equation

$$\Rightarrow \sin\theta \cdot \cos\theta = \frac{-3}{6}$$

$$\Rightarrow \sin 2\theta = -1, \text{ in the range } \theta \in [0, \pi]$$

$$\theta = \frac{3\pi}{4}, \text{ which is included only in the interval } \left[ \frac{\pi}{4}, \pi \right]$$

9. (d) In the above cases  $\sin\theta + \cos\theta = \frac{a}{3}$

$$\text{But } \theta = \frac{3\pi}{4}; \sin \left( \pi - \frac{\pi}{4} \right) + \cos \left( \pi - \frac{\pi}{4} \right) = \frac{a}{3}$$

$$\Rightarrow a = 0$$

10. (d)  $6\sin^2\theta - 8\sin\theta \cdot \cos\theta = 3[1 - \cos 2\theta] - 4 \sin 2\theta = 3 - 3\cos 2\theta - 4 \sin 2\theta$

$$\therefore f'(x) = 12x - 2a = 0 \Rightarrow a = 6x$$

$$\Rightarrow \frac{a}{6} = 3 - 3\cos 2\theta - 4\sin 2\theta$$

$$\Rightarrow \frac{a}{6} = \underbrace{3 - 3\cos 2\theta - 4\sin 2\theta}_A;$$

$$-5 \leq A \leq 5; -2 \leq 3 + A \leq 8; -12 \leq 6(3 + A) \leq 48$$

$$\Rightarrow -12 \leq a \leq 48; [-12, 48]$$

SECTION-VIII (INTEGER TYPE ANSWERS)

1. Let  $16^{\sin^2 x} = y$

$$16^{\cos^2 x} = 16^{1 - \sin^2 x} = 16y^{-1}$$

The equation can be written as  $y + \frac{16}{y} = 10$

$$\Rightarrow y^2 - 10y + 16 = 0 \Rightarrow (y - 8)(y - 2) = 0$$

$$\Rightarrow y = 8, y = 2$$

If  $y = 8$

$$16^{\sin^2 x} = 2^3 \Rightarrow 2^{4\sin^2 x} = 2^3$$

$$\Rightarrow \sin^2 x = \frac{3}{4}$$

$$\Rightarrow \sin^2 x = \pm \sin^2 \pi/3$$

$$\Rightarrow x = n\pi \pm \pi/3. \text{ Which gives 3 solutions in } [0, 3\pi]$$

If  $y = 2$

$$16^{\sin^2 x} = 2 \Rightarrow 4\sin^2 x = 1$$

$$\Rightarrow \sin^2 x = \frac{1}{4}$$

$$\Rightarrow \sin^2 x = \sin^2 \pi/6$$

$$\Rightarrow x = n\pi \pm \pi/6 \text{ this also gives 3 solutions in } [0, 3\pi]$$

Solutions of  $16^{\sin^2 x} + 16^{\cos^2 x} = 10$  in  $x \in [0, 3\pi] = 6$ .

2.  $\tan 5A = \tan \theta \Rightarrow 5A = n\pi + \theta \Rightarrow A = \frac{n\pi}{5} + \frac{\theta}{5}$

$$\tan(3A + B) = 1 \Rightarrow \tan(3A + B) = \tan \frac{\pi}{4}$$

$$\Rightarrow 3A + B = n\pi + \frac{\pi}{4}$$

$$\Rightarrow B = n\pi - \frac{3n\pi}{5} - \frac{3\theta}{5} + \frac{\pi}{4} = \frac{2n\pi}{5} - \frac{3\theta}{5} + \frac{\pi}{4}$$

By the question  $QA = B + \theta - \frac{\pi}{p} (n \in \mathbb{Z})$

$$\Rightarrow \frac{Qn\pi}{5} + \frac{Q\theta}{5} = \frac{2n\pi}{5} - \frac{3\theta}{5} + \frac{\pi}{4} + \theta - \frac{\pi}{p}$$

$$\Rightarrow \frac{Qn\pi}{5} + \frac{Q\theta}{5} = \frac{2n\pi}{5} + \frac{2\theta}{5} + \frac{\pi}{4} - \frac{\pi}{p}$$

$$\Rightarrow Q = 2, p = 4, \text{ Also } \sqrt{p^3 + R} \cdot Q^2 = 10$$

$$\Rightarrow \sqrt{64 + R} \cdot 4 = 10 \Rightarrow R = 9$$

3.  $\sin x + \sin 2x + \sin 3x = \cos x + \cos 2x + \cos 3x$

$$\Rightarrow 2\sin 2x \cdot \cos x + \sin 2x = 2\cos x \cdot \cos 2x + \cos 2x$$

$$\Rightarrow \sin 2x(2\cos x + 1) - \cos 2x(2\cos x + 1) = 0$$

$$\Rightarrow (\sin 2x - \cos 2x)(2\cos x + 1) = 0$$

$$\Rightarrow \cos x = -1/2 \text{ or } \sin 2x = \cos 2x$$

(i)  $\sin 2x = \cos 2x \Rightarrow \cos 2x = \cos \left( \frac{\pi}{2} - 2x \right)$

$$\Rightarrow 2x = 2n\pi \pm \left( \frac{\pi}{2} - 2x \right)$$

$$\Rightarrow x = n\pi \pm \left( \frac{\pi}{4} - x \right) \Rightarrow 2x = n\pi + \pi/4$$

In the range  $(0 \leq x < 2\pi)$ ;  $x = \frac{\pi}{8}, \frac{5\pi}{8}, \frac{9\pi}{8}, \frac{13\pi}{8}$ . Hence

4 solutions.

(ii)  $\cos x = -1/2$

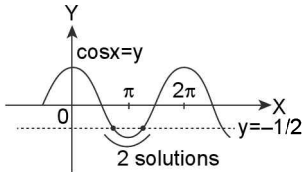

Total = 4 + 2 = 6 solutions.

4.  $\tan(x + \beta) \cdot \tan(x + \gamma) + \tan(x + \gamma) \cdot \tan(x + \alpha) + \tan(x + \alpha) \cdot \tan(x + \beta) = 1$

$$= \frac{\sin(x + \beta) \cdot \sin(x + \gamma)}{\cos(x + \beta) \cdot \cos(x + \gamma)} + \frac{\sin(x + \gamma) \cdot \sin(x + \alpha)}{\cos(x + \gamma) \cdot \cos(x + \alpha)} + \frac{\sin(x + \alpha) \cdot \sin(x + \beta)}{\cos(x + \alpha) \cdot \cos(x + \beta)} = 1$$

$$= \frac{\sin(x + \beta) \cdot \sin(x + \gamma) \cdot \cos(x + \alpha) \cdot \sin(x + \alpha) \cdot \sin(x + \alpha)}{\cos(x + \beta) \cdot \sin(x + \alpha) \cdot \sin(x + \beta) \cdot \cos(x + \gamma)} = 1$$

$$= \sin(x + \gamma) \cdot \sin(2x + \beta + \alpha) + \sin(x + \alpha) \cdot \sin(x + \beta) \cdot \cos(x + \gamma)$$

$$= \cos(x + \beta) \cdot \cos(x + \alpha) \cdot \cos(x + \gamma)$$

$$= \sin(x + \gamma) \cdot \sin(2x + \beta + \alpha) = \cos(x + \gamma) \cdot \cos(2x + \alpha + \beta)$$

$$\Rightarrow \cos(3x + \alpha + \beta + \gamma) = 0$$

$$\Rightarrow 3x + \alpha + \beta + \gamma = (2n + 1) \frac{\pi}{2}$$

$$\Rightarrow x = \frac{n\pi}{3} + \frac{\pi}{6} - \frac{(\alpha + \beta + \gamma)}{3}$$

Comparing this with  $x = \frac{n\pi}{p} + \frac{\pi}{q} - \left(\frac{\alpha + \beta + \gamma}{r}\right)$

$$\Rightarrow p = 3; q = 6; r = 3$$

$$\Rightarrow \sqrt{p^2 + q^2 - r^2} = \sqrt{9 + 36 - 9} = 6$$

5.  $12\sin x + 5\cos x = 2y^2 - 8y + 21$   
 Minimum value of  $2y^2 - 8y + 21 = 13$   
 $12\sin x + 5\cos x$  lies between  $[-13, 13]$   
 Thus  $2y^2 - 8y + 21 = 13 \Rightarrow y = 2$   
 $12\sin x + 5\cos x = 13 = \sin\left(x + \cos^{-1}\left(\frac{12}{13}\right)\right) = 1$   
 $\Rightarrow x + \cos^{-1}\left(\frac{12}{13}\right) = (4n + 1)\frac{\pi}{2}$   
 $\Rightarrow x = 2n\pi + \frac{\pi}{2} - \cos^{-1}\left(\frac{12}{13}\right) = 2n\pi + \sin^{-1}\left(\frac{12}{13}\right)$   
 $= 2n\pi + \tan^{-1}\frac{12}{5}$

Comparing with the  $x = 2n\pi + \tan^{-1}\frac{p}{q}$

$$\Rightarrow p = 12; q = 5; y = r = 2$$

$$\Rightarrow \sqrt{p^2 + q^2 + kr^2} = 15 \Rightarrow \sqrt{169 + 4k} = 15$$

$$\Rightarrow k = 14$$

6.  $\sin x + 2\sin 2x - \sin 3x = 3$ , which can be written as  $\sin 3x - \sin x - 2\sin 2x + 3 = 0 = 2\sin x \cdot \cos 2x - 2\sin 2x + 3 = 0$   
 Adding and subtracting, we get  $\sin^2 x + \cos^2 2x$   
 We can write  $(\sin x + \cos 2x)^2 - 2\sin 2x - \sin^2 x + \cos^2 2x + 3 = 0$   
 Which can be written as  $(\sin x + \cos 2x)^2 + (\sin 2x - 1)^2 + \cos^2 x = 0$   
 Which obviously has no solution.  
 Number of solutions = 0.

7.  $\sin\{x\} = \cos\{x\}$  their graph are

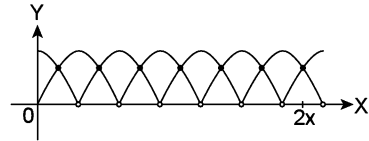

Thus, there are 7 solutions.

8. Let  $f(x) = (e^x - 2)(\sin x - \cos x)(x - \ln 2)(\cos x - 1/\sqrt{2})$  the roots are  $x = \ln 2, \pi/4, 5\pi/4, 7\pi/4, 9\pi/4, \dots$

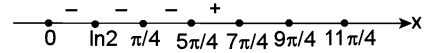

$\forall x \in (0, \ln 2)$ , we get  $f(x) = (-)(-)(-)(+) < 0$

$x \in (\ln 2, \pi/4)$ , we get  $f(x) = (+)(-)(+)(+) < 0$

$x \in (\pi/4, 5\pi/4)$ , we get  $f(x) = (+)(+)(+)(-) < 0$

$\Rightarrow$  Set of positive integer value for which  $f(x) < 0$  where  $x \in (0, \pi)$  is  $\{1, 2, 3\}$

$\Rightarrow x \in \left(\frac{5\pi}{4}, \frac{7\pi}{4}\right)$ ;  $f(x) = (+)(-)(+)(-) = \text{positive}$

The set  $\left(\frac{5\pi}{4}, \frac{7\pi}{4}\right)$  contains positive integers 4 and 5.

$\Rightarrow$  Least positive integer for which  $f(x) > 0$  is 4

9.  $2^{\sin x + \cos y} = 1 \Rightarrow 2^{\sin x + \cos y} = 2^0$

$\Rightarrow \sin x + \cos y = 0 \dots (i)$

$\Rightarrow -\sin x = -\cos y \dots (ii)$

$\Rightarrow \cos y = \sin(-x) \Rightarrow \cos y = \cos\left(\frac{\pi}{2} + x\right)$

$\Rightarrow y = 2n\pi \pm \left(\frac{\pi}{2} + x\right)$

Similarly,  $16^{\sin^2 x + \cos^2 y} = 16^{1/2}$

$\Rightarrow \sin^2 x + \cos^2 y = 1/2$

$\Rightarrow (\sin x + \cos y)^2 - 2\sin x \cdot \cos y = 1/2$

By (i)  $\Rightarrow -2\sin x \cdot \cos y = 1/2$

$\Rightarrow \sin^2 x = 1/4 \Rightarrow \sin^2 x = \sin^2 \frac{\pi}{6}$

$\Rightarrow x = n\pi \pm \frac{\pi}{6}$

Comparing the solution of x and y,  $\frac{\pi}{k} \sim \frac{\pi}{6}$

$\Rightarrow k = 6.$

10.  $\sqrt{\sin x} + 2^{1/4} \cos x = 0$

$\Rightarrow \sqrt{\sin x} = -2^{1/4} \cos x \Rightarrow \sin x = \sqrt{2} \cdot \cos^2 x$

$\Rightarrow -\sqrt{2} \cos^2 x + \sin x = 0 \Rightarrow -\sqrt{2}(1 - \sin^2 x) + \sin x = 0$

$\Rightarrow \sqrt{2} \sin^2 x - \sqrt{2} + \sin x = 0$

$\Rightarrow \sqrt{2} \sin^2 x + 2\sin x - \sin x - \sqrt{2} = 0$

$\Rightarrow (\sin x + \sqrt{2}) + (\sqrt{2} \sin x - 1) = 0$

$\Rightarrow \sin x = -\sqrt{2}$  or  $\sin x = -1/\sqrt{2}$

$\sin x = -\sqrt{2}$  is not possible

$x = 2n\pi + \frac{3\pi}{4}$

Comparing with  $\left(2n\pi + \frac{p\pi}{9}\right)$

$\Rightarrow p = 3, q = 4 \Rightarrow \sqrt{p^2 + q^2} = 5$



2.108 > Trigonometry

11.  $\sin^4 x + \cos^4 x + \sin 2x + \alpha = 0$   
 $\Rightarrow (\sin^2 x + \cos^2 x)^2 - 2\sin^2 x \cdot \cos^2 x + \sin 2x + \alpha = 0$   
 $= \frac{1 - \sin^2 2x}{2} + \sin 2x + \alpha = 0$   
 $\sin 2x = y$   
 $\Rightarrow -\frac{y^2}{2} + y + \alpha + 1 = 0 \Rightarrow y^2 - 2y - 2(\alpha + 1) = 0$   
 $\Rightarrow y = \frac{2 \pm \sqrt{4 + 8\alpha + 8}}{2}$   
 $= 1 - \sqrt{2\alpha + 3}$  (leaving the other solution greater than one)  
 $\Rightarrow \sin 2x = y \Rightarrow 2x = n\pi + (-1)^n \sin^{-1} y$   
 Comparing with  $x = \frac{n\pi}{2} + (-1)^n \frac{\beta}{2}$  where  
 $\beta = \sin^{-1} [1 - \sqrt{2\alpha + 3}]$   
 $\Rightarrow \beta = \sin^{-1} [1 - \sqrt{2\alpha + 3}]$   
 $\Rightarrow k = 3$

12.  $0 \leq \alpha, \beta \leq \pi$  and  $\cos \alpha \cdot \cos \beta \cos(\alpha + \beta) = -1/8$  .....(i)  
 $\Rightarrow \frac{1}{2} [2 \cos \alpha \cos \beta \cos(\alpha + \beta)] = -\frac{1}{8}$   
 $\Rightarrow \frac{1}{2} [\cos(\alpha + \beta) + \cos(\alpha - \beta)] \cos(\alpha + \beta) = -\frac{1}{8}$   
 $\Rightarrow 4 \cos(\alpha + \beta)^2 + 4 \cos(\alpha - \beta) \cdot \cos(\alpha + \beta) + 1 = 0$   
 Let  $\cos(\alpha + \beta) = x$   
 $\Rightarrow 4x^2 + 4 \cos(\alpha - \beta) \cdot x + 1 = 0$   
 For real values of  $x, D \geq 0$   
 $\Rightarrow 16 \cos^2(\alpha - \beta) - 16 \geq 0$   
 $\Rightarrow \cos^2(\alpha - \beta) \geq 1 \Rightarrow \cos^2(\alpha - \beta) = 1$   
 $\Rightarrow \alpha - \beta = -\pi, 0, \pi$  as  $0 \leq \alpha, \beta \leq \pi$   
 $\therefore \alpha - \beta = -\pi, 0, \pi$   
 $\Rightarrow \frac{\alpha}{\beta} = -\frac{\pi}{\beta} + 1, 1 \text{ or } \frac{\pi}{\beta} + 1$  .....(ii)

Also  $\cos \alpha \cos \beta \cos(\alpha + \beta) = -1/8$   
 $\Rightarrow \cos(\beta \pm \pi) \cos \beta \cos(\pm \pi + 2\beta) = -1/8$  or  $\cos \beta \cos \beta \cos 2\beta = -1/8$   
 $\Rightarrow \cos^2 \beta \cos 2\beta = -1/8 \Rightarrow \cos^2 \beta (2 \cos^2 \beta - 1) = -1/8$   
 $\Rightarrow (4 \cos^2 \beta - 1)^2 = 0$   
 $\Rightarrow \cos \beta = \pm 1/2 \Rightarrow \beta = \pi/3 \text{ or } 2\pi/3$  .....(iii)

$\therefore$  From (ii) and (iii), we get  
 $\frac{\alpha}{\beta} = \frac{-\pi}{\pi/3} + 1; \frac{-\pi}{2\pi/3} + 1; \frac{\pi}{\pi/3} + 1; \frac{\pi}{2\pi/3} + 1$   
 $\Rightarrow \frac{\alpha}{\beta} = -3 + 1; \frac{-3}{2} + 1; 1; 3 + 1; \frac{3}{2} + 1$   
 $\Rightarrow \frac{\alpha}{\beta} = -2, -\frac{1}{2}; 1; 4; 5/2$   
 $\therefore$  Integral values  $\frac{\alpha}{\beta} = -2, 1, 4$

$\therefore$  Number of integer value of  $\frac{\alpha}{\beta} = 3$

13.  $|x| + |y| = 4, \sin\left(\frac{\pi x^2}{3}\right) = 1$   
 $\Rightarrow \left. \begin{array}{l} \text{For } x, y \geq 0, x + y = 4 \\ \text{For } x, y \leq 0, x + y = -4 \\ \text{For } x \geq 0, y \leq 0, x - y = 4 \\ \text{For } x \leq 0, y \geq 0, x - y = -4 \end{array} \right\} \dots\dots(i)$

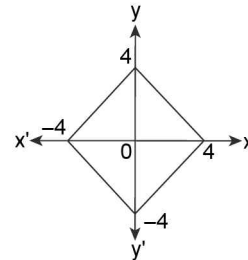

Now  $\sin\left(\frac{\pi x^2}{3}\right) = 1$

$\Rightarrow \frac{\pi x^2}{3} = 2n\pi + \frac{\pi}{2}; n \in \mathbb{Z} \Rightarrow \frac{x^2}{3} = \frac{(4n+1)}{2}, n \in \mathbb{Z}$   
 Now  $-4 \leq x \leq 4 \Rightarrow \frac{4n+1}{2} \in \left[0, \frac{16}{3}\right]$   
 $\Rightarrow 0 \leq x^2 \leq 16 \Rightarrow 0 \leq \frac{\pi x^2}{3} \leq \frac{16\pi}{3} = \frac{32}{3} \cdot \frac{\pi}{2}$   
 $\Rightarrow \frac{\pi x^2}{3} \in \left\{ \frac{\pi}{2}, 2\pi + \frac{\pi}{2}, 4\pi + \frac{\pi}{2} \right\} = \left\{ \frac{\pi}{2}, \frac{5\pi}{2}, \frac{9\pi}{2} \right\}$   
 $\Rightarrow x^2 \in \left\{ \frac{3}{2}, \frac{15}{2}, \frac{27}{2} \right\}$   
 $\Rightarrow x \in \left\{ \pm\sqrt{\frac{3}{2}}, \pm\sqrt{\frac{15}{2}}, \pm\sqrt{\frac{27}{2}} \right\} \in [-4, 4]$

Now for each choices of  $x$  +ve or -ve, there correspond two values of  $y$  in view of 1  
 $\therefore$  Total no of positive ordered pairs =  $6 \times 2 = 12$

14.  $f(x) = \sqrt{\ln(\cos(\sin x))}$  to be defined  
 $\Rightarrow \ln(\cos(\sin x)) \geq 0$   
 $\Rightarrow \cos(\sin x) \geq 1$ ; but  $\cos(\sin \pi) \leq 1 \times x \in \mathbb{R}$   
 $\Rightarrow \cos(\sin x) = 1$   
 $\Rightarrow \sin x = 2n\pi$  i.e.,  $\sin x = 0, \pm 2\pi, \pm 4\pi, \dots$   
 $\Rightarrow \sin x = 0 \Rightarrow x = n\pi$   
 Clearly the number of integer value of  $x$  is only one  $x = 0$ .  
 Number of integral values of  $x = 1$

15.  $\sin \pi x + \cos \pi x = 0$ , which can be written as  
 $\sqrt{2} \left( \frac{1}{\sqrt{2}} \sin \pi x + \frac{1}{\sqrt{2}} \cos \pi x \right) = 0 = \cos \left( \pi x - \frac{\pi}{4} \right) = 0$   
 $\Rightarrow \pi x - \frac{\pi}{4} = (2n+1) \frac{\pi}{2} \Rightarrow x = n + \frac{3}{4}$   
 Given  $x \in [0, 100]$ , hence  $n$  will range from 0 to 99.  
 $x$  will be  $\frac{3}{4}, \frac{7}{4}, \frac{11}{4}, \dots, \frac{399}{4}$   
 $S_n = \frac{n}{2} (2a + (n-1)d) = 50 \left( \frac{402}{4} \right) = 5025$

# Properties and Solution of Triangle

# 3 CHAPTER

## INTRODUCTION

Triangular shapes have fascinated us since our childhood. A triangle has six basic elements namely three angles and three sides. Of these only three elements are independent. The remaining are dependent on these three. This dependence can be expressed in terms of trigonometric ratios. Apart from the six elements, there are many other things associated with triangles e.g., altitudes, medians, perpendicular bisectors, etc., which you have learnt upto now. In fact, there are too many things associated with triangles which will be studied with their minute detail in this chapter.

You must have used different properties of triangle unconsciously but after studying this chapter you would have learnt where they are applied.

For a  $\triangle ABC$ , sides opposite to angles  $A$ ,  $B$  and  $C$  i.e.,  $BC$ ,  $CA$  and  $AB$  are represented by  $a$ ,  $b$  and  $c$  respectively. We denote half of the perimeter of the triangle by  $s$ , i.e.,  $2s = a + b + c$ .

### Geometrical properties of $A$ , $B$ , $C$ and $a$ , $b$ , $c$ .

1.  $A + B + C = 180^\circ$
2.  $a + b > c$ ,  $b + c > a$ ,  $c + a > b$
3.  $a > 0$ ,  $b > 0$ ,  $c > 0$

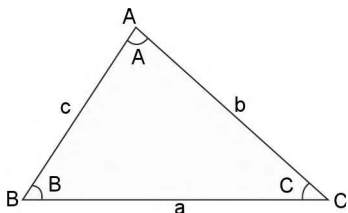

FIGURE 3.1

## PROPERTIES OF TRIANGLE ( $\Delta$ )

Any triangle  $ABC$  has six components i.e., three sides ( $a$ ,  $b$ ,  $c$ ) and three angles ( $\angle A$ ,  $\angle B$ ,  $\angle C$ ).

The identities relating these components are called properties of triangle.

$$\text{e.g., } A + B + C = \pi, \frac{a}{\sin A} = \frac{b}{\sin B} = \frac{c}{\sin C};$$

$$a^2 + b^2 - 2ab \cos C = c^2$$

Most of these properties are cyclic in nature due to periodicity of trigonometric functions.

## SOLUTION OF TRIANGLE ( $\Delta$ )

Given any three of the above six components, generally it is possible to find the remaining three unknown components of triangle using the properties of triangle, this process is known as solving the triangle and the obtained components are called solutions of triangle. For solving a  $\Delta$ , we need some basic tools such as sine formula, cosine formula Napier's Analogy, cotangent formulae, projection formulae etc. Let us discuss them one by one.

## SINE FORMULA

In any triangle  $ABC$ , the ratios of the sides to sine of the opposite angles are equal. i.e.,  $\frac{a}{\sin A} = \frac{b}{\sin B} = \frac{c}{\sin C} = 2R$ , where  $R$  is circumradius of  $\triangle ABC$ .

3.2 ➤ Trigonometry

**Case I:** Let the triangle  $ABC$  be acute angled.  $AD$  is perpendicular to  $BC$ .

$$\sin B = \frac{AD}{c} \text{ or } AD = c \sin B$$

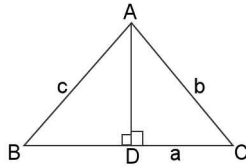

FIGURE 3.2

Again,  $\sin C = \frac{AD}{b}$  or  $AD = b \sin C$

$$\therefore b \sin C = c \sin B$$

$$\Rightarrow \frac{b}{\sin B} = \frac{c}{\sin C} \quad \dots(1)$$

In the similar manner, we can prove that

$$\frac{b}{\sin B} = \frac{a}{\sin A} \quad \dots(2)$$

From the diagram given below,  $\sin A = \frac{a/2}{R}$

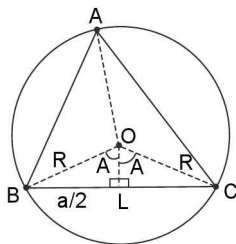

FIGURE 3.3

$$\Rightarrow \sin A = \frac{a}{2R} \Rightarrow \frac{a}{\sin A} = 2R \quad \dots(3)$$

From equations (1), (2) and (3),

$$\text{we have } \frac{a}{\sin A} = \frac{b}{\sin B} = \frac{c}{\sin C} = 2R$$

**Case II:** Let the triangle  $ABC$  be right angled triangle,  $\angle C = 90^\circ$ ,  $\sin C = 1$

$$\Rightarrow \sin A = a/c, \sin B = b/c$$

$$\Rightarrow \frac{a}{\sin A} = \frac{b}{\sin B} = \frac{c}{1} = \frac{c}{\sin C} \quad \dots(4)$$

Also  $\sin B = \frac{b}{2R}$

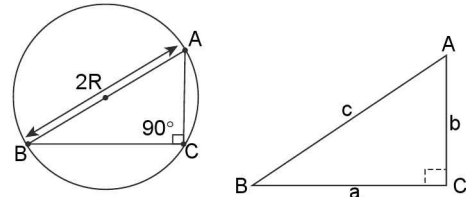

FIGURE 3.4

$$\text{or } \frac{b}{\sin B} = 2R \quad \dots(5)$$

from (4) and (5), we have  $\frac{a}{\sin A} = \frac{b}{\sin B} = \frac{c}{\sin C} = 2R$

**Case III:** Let the triangle  $ABC$  be an obtuse-angled triangle such that  $\angle C > 90^\circ$ .

In  $\triangle ABD$ ,  $\sin B = \frac{AD}{c} \Rightarrow AD = c \sin B$

In  $\triangle ACD$ ,  $\sin(\pi - C) = \frac{AD}{b} \Rightarrow AD = b \sin C$

$$\therefore b \sin C = c \sin B \Rightarrow \frac{b}{\sin B} = \frac{c}{\sin C}$$

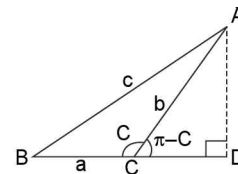

FIGURE 3.5

Similarly,  $\frac{b}{\sin B} = \frac{a}{\sin A} \Rightarrow \frac{a}{\sin A} = \frac{b}{\sin B} = \frac{c}{\sin C} \dots(6)$

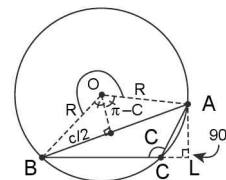

FIGURE 3.6

From the above figure, we have  $\sin(\pi - C) = \frac{c/2}{R}$

$$\Rightarrow \sin C = \frac{c}{2R} \Rightarrow \frac{c}{\sin C} = 2R \quad \dots(7)$$

therefore from (6) and (7), we have

$$\frac{a}{\sin A} = \frac{b}{\sin B} = \frac{c}{\sin C} = 2R.$$

## Applications of sine formula

- To solve a triangle with two angles and one side given.
- To solve a triangle with two sides, an angle opposite to one of sides is given.
- To convert a relation consisting of angles of  $\Delta$  into a relation containing sides.

e.g., Find all component of  $\Delta ABC$  of which

(a)  $a = 5, \angle A = 60^\circ, \angle B = 45^\circ, \angle C = 75^\circ$

(b)  $a = 4, b = 6, \angle A = 60^\circ$ .

**Sol.** (a)  $\frac{a}{\sin A} = \frac{b}{\sin B} = \frac{c}{\sin C}$

$$\Rightarrow \frac{5}{\sqrt{3}/2} = \frac{b}{1/\sqrt{2}} = \frac{c}{\sin 75^\circ}$$

$$\Rightarrow b = \frac{5}{\sqrt{2}} \times \frac{2}{\sqrt{3}}; c = \frac{10}{\sqrt{3}} \sin 75^\circ$$

$$\Rightarrow b = \frac{10}{\sqrt{6}}; c = \frac{10}{\sqrt{3}} \left( \frac{\sqrt{3}+1}{2\sqrt{2}} \right) = \frac{5(\sqrt{3}+1)}{\sqrt{6}}$$

(b) By sine formula

$$\Rightarrow \frac{a}{\sin A} = \frac{b}{\sin B}$$

$$\Rightarrow \sin B = \frac{b \sin A}{a} = \frac{6\sqrt{3}}{2(4)} = \frac{3\sqrt{3}}{4} > 1$$

which is impossible as  $\sin B \in (0, 1]$

$\therefore \Delta$  does not exist

## COSINE FORMULA

In a right angled triangle, an angle can be expressed in terms of the sides of the triangle. Can we express an angle of any triangle in terms of the sides of the triangle?

Yes, there is formula, which relates all sides, an angle.

The formula derived below is known as cosine rule.

$$\text{i.e., } \cos A = \frac{b^2 + c^2 - a^2}{2bc}, \cos B = \frac{a^2 + c^2 - b^2}{2ac},$$

$$\cos C = \frac{a^2 + b^2 - c^2}{2ab}$$

**Case 1:** Let us consider  $\Delta ABC$  to be acute angled triangle, where  $AD$  is perpendicular to  $BC$ , as shown in figure.

$$AB^2 = AD^2 + BD^2$$

$$\Rightarrow AB^2 = AD^2 + (BC - CD)^2 \{ \text{as } BC = BD + DC \}$$

$$\Rightarrow AB^2 = AD^2 + CD^2 + BC^2 - 2BC \cdot CD$$

$$\Rightarrow AB^2 = AC^2 + BC^2 - 2BC \cdot (AC \cos C)$$

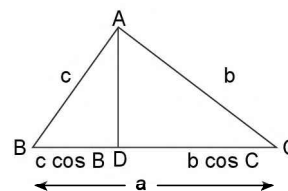

FIGURE 3.7

$$\left\{ \text{as, } AD^2 + DC^2 = AC^2 \text{ and } \frac{DC}{AC} = \cos C \right\}$$

$$\Rightarrow c^2 = b^2 + a^2 - 2a \cdot b \cos C$$

$$\{ \text{given } AB = c, BC = a, AC = b \}$$

$$\text{or } \cos C = \frac{a^2 + b^2 - c^2}{2ab}$$

Similarly,

$$\cos A = \frac{b^2 + c^2 - a^2}{2bc} \text{ and } \cos B = \frac{a^2 + c^2 - b^2}{2ac}$$

$$\Rightarrow \cos A = \frac{b^2 + c^2 - a^2}{2bc}, \cos B = \frac{a^2 + c^2 - b^2}{2ac} \text{ and}$$

$$\cos C = \frac{a^2 + b^2 - c^2}{2ab}$$

**Case 2:** Let  $ABC$  be an obtuse angled  $\Delta$ , obtuse angled at  $A$ . Draw  $BD$  perpendicular to  $AC$ . Then by Euclidean Geometry, we have

$$BC^2 = AB^2 + AC^2 + 2AC \cdot AD$$

$$\therefore a^2 = b^2 + c^2 - 2b \cdot c \cos A \quad \left\{ \because \frac{AD}{c} = \cos(\pi - A) \right\}$$

$$\Rightarrow \cos A = \frac{b^2 + c^2 - a^2}{2bc}$$

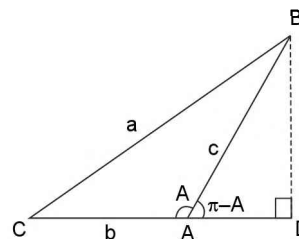

FIGURE 3.8

**Case 3:** Let  $ABC$  be a right angled  $\Delta$ . Then by Euclidean Geometry.

$$a^2 = b^2 + c^2 \text{ and } A = 90^\circ$$

$$\therefore a^2 = b^2 + c^2 - 2bc \cos A \quad (\because \cos A = \cos 90^\circ = 0)$$

$$\therefore \cos A = \frac{b^2 + c^2 - a^2}{2bc}$$

### 3.4 ➤ Trigonometry

Similarly, it may be shown that

$$\cos B = \frac{a^2 + c^2 - b^2}{2ac} \quad \text{and} \quad \cos C = \frac{a^2 + b^2 - c^2}{2ab}$$

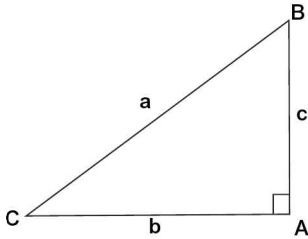

FIGURE 3.9

### Applications of cosine formula

Cosine formulae are used to find the angles of triangle if all the three sides ( $a, b, c$ ) are given.

i.e.,  $\cos A = \frac{b^2 + c^2 - a^2}{2bc}$  gives angle  $A$  when sides  $a, b, c$  are given.

- $\cos A > 0 \Leftrightarrow \angle A$  acute;  $\Leftrightarrow b^2 + c^2 - a^2 > 0$   
 $\Leftrightarrow b^2 + c^2 > a^2$
- $\cos A < 0 \Leftrightarrow \angle A$  obtuse;  $\Leftrightarrow b^2 + c^2 < a^2$
- $\cos A = 0 \Leftrightarrow \angle A = \pi/2 \Leftrightarrow b^2 + c^2 = a^2$

To solve the triangle if two sides and the included angle (e.g.,  $b, c, \angle A$ ) are given.

To solve the triangle if two sides and any one angle (e.g.,  $a, b, \angle A$ ) are given.

e.g., If  $a = 5, b = 7, c = 8$ , find angle  $B$ .

**Sol.**  $\cos B = \frac{a^2 + c^2 - b^2}{2ac}$

$$= \frac{25 + 64 - 49}{2 \times 5 \times 8} = \frac{40}{80} = \frac{1}{2} = \cos 60^\circ$$

$\therefore B = 60^\circ$ .

**ILLUSTRATION 1:** If  $\frac{\sin A}{\sin C} = \frac{\sin(A-B)}{\sin(B-C)}$ , prove that  $a^2, b^2, c^2$  are in AP.

**SOLUTION:**  $\sin A \sin(B-C) = \sin(A-B) \sin C$  [ $\because A+B+C = \pi$ ]  
 $\Rightarrow \sin(B+C) \sin(B-C) = \sin(A-B) \sin(A+B)$  [ $\because \sin(A+B) \sin(A-B) = \sin^2 A - \sin^2 B$ ]  
 $\Rightarrow \sin^2 B - \sin^2 C = \sin^2 A - \sin^2 B$   
 Using sine rule, we get  
 $\Rightarrow k^2 b^2 - k^2 c^2 = k^2 a^2 - k^2 b^2$ ; where  $k = 2R$ .  
 $\Rightarrow 2b^2 = a^2 + c^2 \qquad \qquad \qquad \Rightarrow a^2, b^2, c^2$  are in A.P.

**ILLUSTRATION 2:** If  $A, B, C$  are in A.P., prove that  $2 \cos \frac{A-C}{2} = \frac{a+c}{\sqrt{a^2 + c^2 - ac}}$

**SOLUTION:**  $\because A, B, C$  are in A.P.; we have  $2B = A + C$   
 But  $A + B + C = 180^\circ \Rightarrow B = 60^\circ$  and  $A + C = 120^\circ$   
 Now  $\cos B = \frac{a^2 + c^2 - b^2}{2ac} = \cos 60^\circ = \frac{1}{2}$   
 $\Rightarrow ac = a^2 + c^2 - b^2$   
 $\Rightarrow a^2 + c^2 - ac = b^2 \qquad \qquad \qquad \dots(i)$   
 $\text{R.H.S.} = \frac{a+c}{\sqrt{a^2 - ac + c^2}} = \frac{a+c}{b}$  [From (1)]  
 $= \frac{\sin A + \sin C}{\sin B}$  (Using sine Rule)  
 $= \frac{2 \sin \left( \frac{A+C}{2} \right) \cos \left( \frac{A-C}{2} \right)}{\sin 60^\circ} = \frac{2 \cos 30^\circ \cos \left( \frac{A-C}{2} \right)}{\sin 60^\circ} = 2 \cos \left( \frac{A-C}{2} \right) = \text{L.H.S.}$

**ILLUSTRATION 3:** Prove that,  $a \cos \frac{B-C}{2} = (b+c) \sin \frac{A}{2}$ .

**SOLUTION:** we have  $\frac{b+c}{a} = \frac{\sin B + \sin C}{\sin A} = \frac{2 \sin \frac{B+C}{2} \cos \frac{B-C}{2}}{2 \sin \frac{A}{2} \cos \frac{A}{2}} = \frac{\cos \frac{A}{2} \cos \frac{B-C}{2}}{\sin \frac{A}{2} \cos \frac{A}{2}} = \frac{\cos \frac{B-C}{2}}{\sin \frac{A}{2}}$ .

$\therefore (b+c) \sin \frac{A}{2} = a \cos \frac{B-C}{2}$ .

**ILLUSTRATION 4:** Prove that in a  $\triangle ABC$

(a)  $\frac{\cos B}{\cos C} = \frac{c - b \cos A}{b - c \cos A}$                       (b)  $\sum \frac{\cos A}{c \cos B + b \cos C} = \frac{a^2 + b^2 + c^2}{2abc}$

**SOLUTION:** (a) L.H.S =  $\frac{\cos B}{\cos C} = \frac{(a^2 + c^2 - b^2)/2ac}{(a^2 + b^2 - c^2)/2ab} = \frac{ba^2 + bc^2 - b^3}{ca^2 + cb^2 - c^3}$

R.H.S =  $\frac{c - b \cos A}{b - c \cos A} = \frac{c - b \left[ \frac{b^2 + c^2 - a^2}{2bc} \right]}{b - c \left[ \frac{b^2 + c^2 - a^2}{2bc} \right]} = \frac{2bc^2 - b(b^2 + c^2 - a^2)}{2b^2c - c(b^2 + c^2 - a^2)} = \frac{bc^2 - b^3 + ba^2}{b^2c - c^3 + a^2c}$

$\therefore$  **L.H.S = R.H.S**

(b) L.H.S =  $\sum \frac{\cos A}{c \cos B + b \cos C}$

Consider  $\frac{\cos A}{c \cos B + b \cos C} = \frac{(b^2 + c^2 - a^2)/2bc}{c \frac{(a^2 + c^2 - b^2)}{2ac} + b \frac{(a^2 + b^2 - c^2)}{2ab}} = \frac{(b^2 + c^2 - a^2)}{bc} \cdot \frac{a}{2a^2}$

$= \frac{b^2 + c^2 - a^2}{2abc} \Rightarrow \therefore \sum \frac{\cos A}{c \cos B + b \cos C} = \sum \frac{b^2 + c^2 - a^2}{2abc}$

$= \frac{(b^2 + c^2 - a^2) + (a^2 + c^2 - b^2) + (a^2 + b^2 - c^2)}{2abc} = \frac{a^2 + b^2 + c^2}{2abc} = \text{R.H.S}$

**ILLUSTRATION 5:** Prove that,  $b^2 \sin 2C + c^2 \sin 2B = 2bc \sin A$

**Proof:** L.H.S =  $b^2 \sin 2C + c^2 \sin 2B$

$= b^2 [2 \sin C \cos C] + c^2 [2 \sin B \cos B] = b^2 \left[ 2 \left( \frac{c}{2R} \right) \left( \frac{a^2 + b^2 - c^2}{2ab} \right) \right] + c^2 \left[ 2 \left( \frac{b}{2R} \right) \left( \frac{a^2 + c^2 - b^2}{2ac} \right) \right]$

$= \frac{bc}{2aR} (a^2 + b^2 - c^2) + \frac{bc}{2aR} (a^2 + c^2 - b^2) = \frac{bc}{2aR} (a^2 + b^2 - c^2 + a^2 + c^2 - b^2)$

$= \frac{bc(2a^2)}{2aR} = \frac{abc}{R} = 2bc \left( \frac{a}{2R} \right) = 2bc \sin A = \text{R.H.S. (By sine formula)}$



### PROJECTION FORMULA

Projection of a line segment  $AB$  on the other line  $L$  is a line segment having its end points as the feet of the perpendiculars drawn from  $A$  and  $B$  on  $L$ .

In a  $\triangle ABC$ ,  $BD$  and  $DC$  are the projections of  $AB$  and  $AC$  on  $BC$  where  $AD$  is perpendicular on  $BC$ .

$$a = BC = BD + DC = c \cos B + b \cos C$$

Similarly,  $b = a \cos C + c \cos A$  and  $c = a \cos B + b \cos A$ .

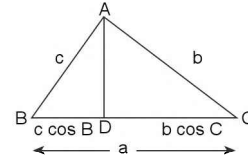

FIGURE 3.10

**ILLUSTRATION 6:** (a) Prove that  $a(\cos B + \cos C) = 2(b + c)\sin^2 A/2$

(b) Prove that  $a(\cos C - \cos B) = 2(b - c)\cos^2 A/2$

**SOLUTION:** (a) R.H.S. =  $2(b + c)\sin^2 A/2 = (b + c)2\sin^2 A/2$   
 $= (b + c)(1 - \cos A) = c + b - b \cos A - c \cos A$   
 $= a \cos B + b \cos A + c \cos A + a \cos C - b \cos A - c \cos A = a(\cos B + \cos C) = \text{L.H.S.}$   
 (b) R.H.S. =  $2(b - c)\cos^2 A/2 = (b - c)(1 + \cos A)$   
 $= b - c + b \cos A - c \cos A = c \cos A + a \cos C - a \cos B - b \cos A + b \cos A - c \cos A$   
 $= a(\cos C - \cos B)$  (putting for  $b$  and  $c$ ) = L.H.S.

**ILLUSTRATION 7:** For a  $\triangle ABC$  show that,  $b \cos B = c \cos(A - B) + a \cos(C + B)$ .

**SOLUTION:** Note that the rule of thumb is that whenever you have to prove something, always take up the bigger expression and reduce it to the smaller one.

Hence considering R.H.S.

$$\begin{aligned} &= c(\cos A \cos B + \sin A \sin B) + a(\cos C \cos B - \sin C \sin B) \\ &= [c \cos A + a \cos C] \cos B + [c \sin A - a \sin C] \sin B \\ &= b \cos B + [c \sin A - a \sin C] \sin B \quad (\text{By Projection rule}) \quad \dots (i) \end{aligned}$$

$$\begin{aligned} \text{Also from sine rule, } \frac{\sin A}{a} &= \frac{\sin C}{c} \Rightarrow c \sin A = a \sin C \\ \Rightarrow c \sin A - a \sin C &= 0 \end{aligned}$$

$\therefore$  (1) becomes,  $b \cos B = \text{R.H.S.}$  **Hence proved.**

**ILLUSTRATION 8:** Prove that  $(b + c) \cos A + (c + a) \cos B + (a + b) \cos C = a + b + c$ .

**Proof:**  $(b + c) \cos A + (c + a) \cos B + (a + b) \cos C$ .

$$\begin{aligned} \text{Consider } (b + c) \cos A &= (b + c) \left[ \frac{b^2 + c^2 - a^2}{2bc} \right] \\ &= \frac{1}{2abc} a(b + c)[b^2 + c^2 - a^2] = \frac{1}{2abc} (ab + ac)[b^2 + c^2 - a^2] \\ &= \frac{1}{2abc} (ab^3 + abc^2 - a^3b + ab^2c + ac^3 - a^3c) = \frac{1}{2abc} [(ab^3 - ba^3) + (ac^3 - a^3c) + abc(b + c)] \end{aligned}$$

$$\therefore \text{L.H.S.} = \sum (b + c) \cos A$$

$$\begin{aligned} &= \frac{1}{2abc} [abc(b + c) + abc(c + a) + (abc)(a + b)] \\ &= \frac{1}{2abc} (abc)[2(a + b + c)] = (a + b + c) = \text{R.H.S.} \quad \text{Hence Proved.} \end{aligned}$$

**Aliter:**

$$\begin{aligned}
 & b \cos A + c \cos A + c \cos B + a \cos B + a \cos C + b \cos C \\
 &= (a \cos B + b \cos A) + (b \cos C + c \cos B) + (a \cos C + c \cos A) = c + a + b = a + b + c.
 \end{aligned}$$

**ILLUSTRATION 9:** Prove that  $a(b^2 + c^2) \cos A + b(c^2 + a^2) \cos B + c(a^2 + b^2) \cos C = 3abc$

**SOLUTION:**  $(ab^2 \cos A + ba^2 \cos B) + (ac^2 \cos A + ca^2 \cos C) + (bc^2 \cos B + b^2c \cos C)$   
 $= ab(b \cos A + a \cos B) + ac(c \cos A + a \cos C) + bc(c \cos B + b \cos C)$   
 $= abc + acb + bca$  (by using projection formulae  $c = b \cos A + a \cos B$  etc)  $= 3abc$

**ILLUSTRATION 10:** Prove that  $\frac{\cos A + \cos C}{a + c} + \frac{\cos B}{b} - \frac{1}{b} = 0$

**SOLUTION:** L.H.S  $= \frac{\cos A + \cos C}{a + c} + \frac{\cos B}{b} - \frac{1}{b} = 0 = \frac{b \cos A + b \cos C + a \cos B + c \cos B}{b(a + c)} - \frac{1}{b}$   
 $= \frac{(b \cos A + a \cos B) + (b \cos C + c \cos B)}{b(a + c)} - \frac{1}{b}$   
 $= \frac{(c + a)}{b(a + c)} - \frac{1}{b} = \frac{1}{b} - \frac{1}{b} = 0 = R.H.S.$  **Hence Proved**

## TEXTUAL EXERCISE-1 (SUBJECTIVE)

- Prove that  $\sin \frac{B-C}{2} = \frac{b-c}{a} \cos A/2$
  - Prove that  $a(b \cos C - c \cos B) = b^2 - c^2$
  - Prove that  $\frac{\sin(B-C)}{\sin(B+C)} = \frac{b^2 - c^2}{a^2}$
  - In triangle  $ABC$ , if  $\frac{b+c}{11} = \frac{c+a}{10} = \frac{a+b}{9}$ , then prove that  $\frac{\cos A}{12} = \frac{\cos B}{9} = \frac{\cos C}{2}$ .
- In a triangle  $ABC$  if  $\frac{1}{a+c} + \frac{1}{b+c} = \frac{3}{a+b+c}$ , then find the measure of angle  $C$ .
  - Prove that  $a^2 + b^2 + c^2 = 2(bc \cos A + ca \cos B + ab \cos C)$
  - Prove that  $(a^2 - b^2 + c^2) \tan B = (a^2 + b^2 - c^2) \tan C$
  - Prove that  $c^2 - (a + b)^2 = (a - b)^2 \cos^2 C/2 + (a + b)^2 \sin^2 C/2$
- The sides of a triangle are 8 cm, 10 cm and 12 cm, then prove that the greatest angle is double that of the smallest angle.

4. In a triangle  $ABC$ , prove that:

$$\begin{aligned}
 & \frac{\cos^2 B - \cos^2 C}{b + c} + \frac{\cos^2 C - \cos^2 A}{c + a} + \\
 & \frac{\cos^2 A - \cos^2 B}{a + b} = 0
 \end{aligned}$$

5. In a triangle  $ABC$ , if  $2 \cos A = \frac{\sin B}{\sin C}$ , prove that the triangle is isosceles.

6. (a) In a triangle  $ABC$ , prove that  $\frac{b^2 - c^2}{a^2} \sin 2A + \frac{c^2 - a^2}{b^2} \sin 2B + \frac{a^2 - b^2}{c^2} \sin 2C = 0$

(b) In any  $\Delta ABC$ , prove that

(i)  $a \sin(B - C) + b \sin(C - A) + c \sin(A - B) = 0$

(ii)  $\sum \frac{a^2 \sin(B - C)}{\sin B + \sin C} = 0$

(iii)  $\sum \frac{a^2 \sin(B - C)}{b^2 - c^2} = \sin A + \sin B + \sin C$

7. In a triangle  $ABC$ , if  $\cos A + \cos B + \cos C = 3/2$ , prove that the triangle is equilateral.



3.8 > Trigonometry

8. In any triangle  $ABC$ , show that  $\frac{\sin^2 A + \sin A + 1}{\sin A} \geq 3$ .
9. (a) If in a  $\Delta ABC$ ,  $\frac{2 \cos A}{a} + \frac{\cos B}{b} + \frac{2 \cos C}{c} = \frac{a}{bc} + \frac{b}{ca}$  then find the angle  $A$ .  
 (b) In  $\Delta ABC$ ,  $D$  is the mid point of  $BC$ . If  $AD \perp AC$ , then prove that  $\cos A \cos C = \frac{2(c^2 - a^2)}{3ac}$   
 (c) If in a  $\Delta ABC$ ,  $\frac{\tan A}{1} = \frac{\tan B}{2} = \frac{\tan C}{3}$ , then prove that  $6\sqrt{2}a = 3\sqrt{5}b = 2\sqrt{10}c$ .
10. In  $\Delta ABC$ , prove that  $b \cos \theta = c \cos (A - \theta) + a \cos (C + \theta)$  if  $\theta$  be any angle.
11. Solve  $b \cos^2 C/2 + c \cos^2 B/2$  in terms of  $k$ , where  $k$  is perimeter of the  $\Delta ABC$ .
12. If in a  $\Delta ABC$ ,  $A = 90^\circ$  and  $c, \sin B, \cos B$  are rational numbers, then show that  $a$  and  $b$  are also rational numbers.
13. (a) The perimeter of a triangle is 6 times the A.M. of the sine of angles. If the side  $a$  is 1, then find angle  $A$ .
- (b) In  $\Delta ABC$ ,  $\angle B = \pi/3$  and  $\angle C = \pi/4$ . If  $D$  divides  $BC$  internally in the ratio 1:3, then find  $\frac{\sin \angle BAD}{\sin \angle CAD}$ .
- (c) In  $\Delta ABC$ , if  $A$  is greater than  $B$  and  $A, B$  are solutions of equation  $3 \sin x - 4 \sin^3 x - k = 0$ , where  $(0 < k < 1)$ , then find  $\angle C$ .
- (d) In  $\Delta ABC$ , if  $D$  divides  $BC$  internally in the ratio 1 : 3, and  $\angle BAD$  is  $\pi/4$ , where as  $\angle CAD$  is  $\pi/3$ , then find the ratio  $\sin B : \sin C$ .
14. In a  $\Delta ABC$  if  $\cot A \cot B, \cot C$  are in A.P., then find whether  $a^2, b^2, c^2$  are in A.P./G.P./H.P.
15. In a triangle  $ABC$ , if  $a$  is the arithmetic mean and  $b, c$  are the two geometric means between same two positive numbers. Then evaluate  $\frac{\sin^3 B + \sin^3 C}{\sin A \sin B \sin C}$ .
16. In a triangle  $ABC$ , if  $a = mb$  and  $\cos A = \frac{m+1}{2} \sqrt{\frac{1-m^2}{m}}$ , then show that there exists two values  $c_1$  and  $c_2$  of third side ( $0 < m < 1$ ) such that  $c_1 = mc_2$ .
17. If in a triangle  $\cos \frac{A}{2} = \frac{1}{2} \left( \frac{b}{c} + \frac{c}{b} \right)^{1/2}$ . Prove that the area of the square described with one side of triangle as diagonal is equal to that of the rectangle, its length and breadth as having other two sides of triangle.

Answer Keys

2. (a)  $C = 60^\circ$       9. (a)  $A = 90^\circ$       11.  $k/2$       13. (a)  $A = \pi/6$  or  $5\pi/6$     (b)  $1/\sqrt{6}$     (c)  $2\pi/3$     (d)  $\sqrt{6}$   
 14. A.P.      15. 2

TEXTUAL EXERCISE-1 (OBJECTIVE)

1. In a triangle  $ABC$ ,  $a = 5, b = 7$  and  $\sin A = 3/4$ , how many such triangles are possible?  
 (a) 1      (b) 0  
 (c) 2      (d) infinite
2. If the angles of triangle  $ABC$  be in A.P., then  
 (a)  $c^2 = a^2 + b^2 - ab$     (b)  $b^2 = a^2 + c^2 - ac$   
 (c)  $a^2 = b^2 + c^2 - ac$     (d)  $b^2 = a^2 + c^2$
3. In  $\Delta ABC$ ,  $\frac{\sin B}{\sin(A+B)}$  is equal to  
 (a)  $\frac{b}{a+b}$       (b)  $\frac{b}{c}$   
 (c)  $\frac{c}{b}$       (d) None of these
4. In  $\Delta ABC$ ,  $\frac{\sin(A-B)}{\sin(A+B)}$  is equal to  
 (a)  $\frac{a^2 - b^2}{c^2}$       (b)  $\frac{a^2 + b^2}{c^2}$   
 (c)  $\frac{c^2}{a^2 - b^2}$       (d)  $\frac{c^2}{a^2 + b^2}$
5. In a  $\Delta ABC$ , if  $c^2 + a^2 - b^2 = ac$ , then  $\angle B$  is equal to  
 (a)  $\frac{\pi}{6}$       (b)  $\frac{\pi}{4}$   
 (c)  $\frac{\pi}{3}$       (d) None of these
6. In  $\Delta ABC$ ,  $b^2 \cos 2A - a^2 \cos 2B$  is equal to  
 (a)  $b^2 - a^2$       (b)  $b^2 - c^2$   
 (c)  $c^2 - a^2$       (d)  $a^2 + b^2 + c^2$

7. In  $\triangle ABC$ ,  $a \sin(B - C) + b \sin(C - A) + c \sin(A - B)$  is equal to  
 (a) 0 (b)  $a + b + c$   
 (c)  $a^2 + b^2 + c^2$  (d)  $2(a^2 + b^2 + c^2)$
8. In  $\triangle ABC$ ,  $\operatorname{cosec}A(\sin B \cos C + \cos B \sin C)$  is equal to  
 (a)  $c/a$  (b)  $a/c$   
 (c) 1 (d)  $c/ab$
9. In  $\triangle ABC$ , if  $a = 3$ ,  $b = 4$ ,  $c = 5$ , then  $\sin 2B$  equals  
 (a)  $4/5$  (b)  $3/20$   
 (c)  $24/25$  (d)  $1/50$
10. In  $\triangle ABC$ ,  $2b^2 = a^2 + c^2$ , then  $\frac{\sin 3B}{\sin B}$  is equal to  
 (a)  $\frac{c^2 - a^2}{2ca}$  (b)  $\frac{c^2 - a^2}{ca}$   
 (c)  $\left(\frac{c^2 - a^2}{ca}\right)^2$  (d)  $\left(\frac{c^2 - a^2}{2ca}\right)^2$
11. If the angles of a triangle are in the ratio 1 : 2 : 3, then their corresponding sides are in the ratio  
 (a) 1 : 2 : 3 (b)  $1 : \sqrt{3} : 2$   
 (c)  $\sqrt{2} : \sqrt{3} : 3$  (d)  $1 : \sqrt{3} : 3$
12. If the angles  $A, B, C$ , of a triangle are in A.P., and the sides  $a, b, c$  opposite to these angles are in G.P., then  $a^2, b^2, c^2$  are in  
 (a) A. P. (b) H. P.  
 (c) G. P. (d) None of these
13. If  $a^2, b^2, c^2$  are in A.P., then which of the following are also in A.P.?  
 (a)  $\sin A, \sin B, \sin C$  (b)  $\tan A, \tan B, \tan C$   
 (c)  $\cot A, \cot B, \cot C$  (d) None of these
14. In a  $\triangle ABC$ , if  $\frac{b+c}{11} = \frac{c+a}{12} = \frac{a+b}{13}$ , then  $\cos C =$   
 (a)  $7/5$  (b)  $5/7$   
 (c)  $17/36$  (d)  $16/17$
15. In a  $\triangle ABC$ , if  $b = 20$ ,  $c = 21$  and  $\sin A = 3/5$ . then  $a$  is equal to  
 (a) 12 (b) 13  
 (c) 14 (d) 15
16. If the sides of triangle be 6, 10 and 14, then the triangle is  
 (a) Obtuse angled (b) Acute angled  
 (c) Right angled (d) Equilateral
17. In any  $\triangle ABC$  if  $a \cos B = b \cos A$ , then the triangle is  
 (a) Equilateral triangle (b) Isosceles triangle  
 (c) Scalene (d) Right angled
18. If in a triangle  $ABC$ ,  $2 \cos A = \sin B \operatorname{cosec} C$ , then  
 (a)  $a = b$  (b)  $b = c$   
 (c)  $c = a$  (d)  $2a = bc$

## Answer Keys

1. (b) 2. (b) 3. (b) 4. (a) 5. (c) 6. (a) 7. (a) 8. (c) 9. (c) 10. (d)  
 11. (b) 12. (a,b,c) 13. (c) 14. (b) 15. (b) 16. (a) 17. (b) 18. (c)

### ■ NAPIER'S ANALOGY (TANGENT RULE)

We have read about a sine formula and a cosine formula. Is there a tangent formula also?

Yes, the tangent rule is also called Napier's analogy.

Napier's Analogy states that

$$\text{in any triangle } ABC, \tan \frac{(A-B)}{2} = \frac{a-b}{a+b} \cot \frac{C}{2}.$$

**Proof:** In  $\triangle ABC$ ,  $\frac{a}{\sin A} = \frac{b}{\sin B} = \frac{c}{\sin C} = k$  (by sine rule)

$$\Rightarrow a = k \sin A, b = k \sin B, c = k \sin C, \text{ Now}$$

$$\text{R.H.S.} = \left(\frac{a-b}{a+b}\right) \cot \frac{C}{2} = \left(\frac{k \sin A - k \sin B}{k \sin A + k \sin B}\right) \cot \frac{C}{2}$$

$$\begin{aligned} &= \frac{2 \cos \left(\frac{A+B}{2}\right) \sin \left(\frac{A-B}{2}\right)}{2 \sin \left(\frac{A+B}{2}\right) \cos \left(\frac{A-B}{2}\right)} \cdot \frac{\cos \frac{C}{2}}{\sin \frac{C}{2}} \\ &= \frac{\sin \left(\frac{A-B}{2}\right)}{\cos \left(\frac{A-B}{2}\right)} \quad \therefore \begin{cases} \cos \left(\frac{A+B}{2}\right) = \sin \frac{C}{2} \\ \sin \left(\frac{A+B}{2}\right) = \cos \frac{C}{2} \end{cases} \\ &= \tan \left(\frac{A-B}{2}\right) = \text{L.H.S.} \quad \text{Hence proved.} \end{aligned}$$

Similarly, you can try it yourself to prove that

$$\tan \frac{B-C}{2} = \frac{b-c}{b+c} \cot \frac{A}{2}; \tan \frac{C-A}{2} = \frac{c-a}{c+a} \cot \frac{B}{2}$$

**ILLUSTRATION 11:** In any  $\triangle ABC$ , if  $a = 2$ ,  $b = \sqrt{3} + 1$  and  $C = 60^\circ$ , solve the triangle i.e, find other three elements of triangle  $ABC$ .

**SOLUTION:** Using tangent rule,  $\tan \frac{A-B}{2} = \frac{2 - (\sqrt{3} + 1)}{2 + (\sqrt{3} + 1)} \cot \frac{60^\circ}{2} = \frac{1 - \sqrt{3}}{\sqrt{3}(1 + \sqrt{3})} \cdot \sqrt{3} = \frac{(1 - \sqrt{3})}{(1 + \sqrt{3})} = \frac{-(\sqrt{3} - 1)}{(\sqrt{3} + 1)}$

$$\Rightarrow \frac{B-A}{2} = 15^\circ \left[ \because \tan 15^\circ = \frac{\sqrt{3}-1}{\sqrt{3}+1} \right] \quad \text{or, } B - A = 30^\circ$$

Also  $A + B = 120^\circ$  [As  $A + B + C = \pi$ ]

$\therefore B = 75^\circ$  and  $A = 45^\circ$

Using sine rule,  $\frac{2}{\sin 45^\circ} = \frac{c}{\sin 60^\circ} \Rightarrow c = \sqrt{6}$

**ILLUSTRATION 12:** If in a  $\triangle ABC$ ,  $b = 2c$ , then find the value of  $\cot \frac{A}{2} \cot \frac{B-C}{2}$ .

**SOLUTION:** By Napier's Analogy  $\tan \left( \frac{B-C}{2} \right) = \frac{b-c}{b+c} \cot \frac{A}{2}$

$$\Rightarrow \cot \frac{A}{2} \cot \left( \frac{B-C}{2} \right) = \frac{b+c}{b-c} = \frac{2c+c}{2c-c} = \frac{3c}{c} = 3$$

**ILLUSTRATION 13:** Let  $ABC$  be a right angled  $\triangle$  in which hypotenuse is four times the length of perpendicular drawn from the vertex containing right angle, then find the angles of  $\triangle$ .

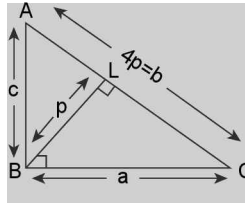

FIGURE 3.11

**SOLUTION:** Let  $ABC$  be a right  $\triangle$  with right  $\angle$  at vertex  $B$  and let  $BL \perp AC$  and  $BL = p$

$$\Rightarrow AC = 4p = b$$

$$\text{Now area of } \triangle ABC = \frac{1}{2}ac = \frac{1}{2}(4p)(p) \Rightarrow ac = 4p^2 \quad \dots(i)$$

$$\text{Now } (a + c)^2 = a^2 + c^2 + 2ac = a^2 + c^2 + 8p^2 = b^2 + 8p^2 = 16p^2 + 8p^2 = 24p^2$$

$$\text{and } (a - c)^2 = a^2 + c^2 - 2ac = b^2 - 2(4p^2) = 16p^2 - 8p^2 = 8p^2 \text{ (using (i))}$$

$$\therefore \left( \frac{a-c}{a+c} \right)^2 = \frac{8p^2}{24p^2} = \frac{1}{3} \Rightarrow \frac{a-c}{a+c} = \pm \frac{1}{\sqrt{3}} \quad \dots(ii)$$

By Napier's Analogy

$$\tan \left( \frac{A-C}{2} \right) = \frac{a-c}{a+c} \cot \frac{B}{2} = \frac{a-c}{a+c} \cot 45^\circ = \frac{a-c}{a+c} \quad \therefore \tan \left( \frac{A-C}{2} \right) = \pm \left( \frac{1}{\sqrt{3}} \right)$$

$$\Rightarrow \tan \left( \frac{A-C}{2} \right) = \frac{1}{\sqrt{3}} \text{ for } A > C \text{ and } \tan \left( \frac{A-C}{2} \right) = \frac{-1}{\sqrt{3}} \text{ for } A < C$$

$$\Rightarrow \frac{A-C}{2} = 30^\circ \text{ for } A > C \text{ and } \frac{A-C}{2} = -30^\circ \text{ for } A < C$$

$$\Rightarrow A - C = 60^\circ \text{ for } A > C \text{ and } C - A = 60^\circ \text{ for } A < C$$

$$\text{Also } A + C = 90^\circ \text{ as } \angle B = 90^\circ$$

$$\Rightarrow \angle A = 75^\circ, \angle B = 90^\circ, \angle C = 15^\circ \text{ for } A > C$$

$$\text{or } \angle A = 15^\circ, \angle B = 90^\circ, \angle C = 75^\circ \text{ for } A < C$$

**ILLUSTRATION 14:**  $\triangle ABC$  with  $\angle A$  acute,  $b = 2$  and  $c = (\sqrt{3} - 1)$  has area  $(\sqrt{3} - 1)/2$ , then find the measures of angles of triangle.

**SOLUTION:** ar  $\triangle ABC = \frac{1}{2}bc \sin A$

$$\Rightarrow \frac{\sqrt{3}-1}{2} = \frac{1}{2}(2)(\sqrt{3}-1)\sin A \Rightarrow \sin A = \frac{1}{2} \Rightarrow \angle A = 30^\circ$$

$$\text{By Napier's Analogy } \tan\left(\frac{B-C}{2}\right) = \frac{b-c}{b+c} \cot \frac{A}{2}$$

$$\Rightarrow \tan\left(\frac{B-C}{2}\right) = \frac{2-(\sqrt{3}-1)}{2+(\sqrt{3}-1)} \cot\left(\frac{30^\circ}{2}\right)$$

$$\Rightarrow \tan\left(\frac{B-C}{2}\right) = \frac{3-\sqrt{3}}{1+\sqrt{3}} \cot 15^\circ = \frac{3-\sqrt{3}}{\sqrt{3}+1} \times \frac{\sqrt{3}+1}{\sqrt{3}-1} = \sqrt{3}$$

$$\Rightarrow \frac{B-C}{2} = 60^\circ \Rightarrow B-C = 120^\circ$$

$$\text{Also } B + C = 150^\circ \text{ as } \angle A = 30^\circ$$

$$\Rightarrow \angle B = 135^\circ \text{ and } \angle C = 15^\circ$$

### ■ TO FIND THE SINE, COSINE AND TANGENT OF THE HALF-ANGLES IN TERMS OF THE SIDES

In any triangle  $ABC$ , we have  $\cos A = \frac{b^2 + c^2 - a^2}{2bc}$

$$\begin{aligned} \therefore 2\sin^2 \frac{A}{2} &= 1 - \cos A = -\frac{b^2 + c^2 - a^2}{bc} \\ &= \frac{2bc - (b^2 + c^2 - a^2)}{2bc} = \frac{a^2 - (b^2 + c^2 - 2bc)}{2bc} \\ &= \frac{a^2 - (b-c)^2}{2bc} = \frac{(a+b-c)(a-b+c)}{2bc} \end{aligned}$$

$$\text{Let } a + b + c = 2s, \text{ then } a + b - c = a + b + c - 2c = 2s - 2c = 2(s - c)$$

$$\text{and } a - b + c = a + b + c - 2b = 2s - 2b = 2(s - b)$$

$$\therefore 2\sin^2 \frac{A}{2} = \frac{2(s-c) \times 2(s-b)}{2bc}$$

$$\Rightarrow \sin^2 \frac{A}{2} = \frac{(s-c)(s-b)}{bc}$$

Since in a triangle,  $A$  is always less than  $180^\circ$ ,  $A/2$  is always less than  $90^\circ$ . Therefore sine of  $A/2$  is always positive.

$$\therefore \sin \frac{A}{2} = \sqrt{\frac{(s-b)(s-c)}{bc}}$$

Similarly, it can be proved that  $\sin \frac{B}{2} = \sqrt{\frac{(s-a)(s-c)}{ac}}$ ;

$$\sin \frac{C}{2} = \sqrt{\frac{(s-a)(s-b)}{ab}}$$

$$\begin{aligned} \text{Again, } 2\cos^2 \frac{A}{2} &= 1 + \cos A = 1 + \frac{b^2 + c^2 - a^2}{2bc} \\ &= \frac{2bc + b^2 + c^2 - a^2}{2bc} \end{aligned}$$

$$= \frac{(b+c)^2 - a^2}{2bc} = \frac{(b+c+a)(b+c-a)}{2bc};$$

$$\text{where } b + c - a = b + c + a - 2a = 2s - 2a = 2(s - a)$$

### 3.12 > Trigonometry

$$\Rightarrow 2 \cos^2 \frac{A}{2} = \frac{2s \times 2(s-a)}{2bc} \Rightarrow \cos^2 \frac{A}{2} = \frac{s(s-a)}{bc}$$

since  $A/2$  is less than  $90^\circ \Rightarrow \cos A/2 > 0$ .

$$\Rightarrow \cos \frac{A}{2} = \sqrt{\frac{s(s-a)}{bc}}$$

Similarly,  $\cos \frac{B}{2} = \sqrt{\frac{s(s-b)}{ac}}$  and

$$\cos \frac{C}{2} = \sqrt{\frac{s(s-c)}{ab}}$$

$$\text{Also } \tan \frac{A}{2} = \frac{\sin A/2}{\cos A/2} = \sqrt{\frac{(s-b)(s-c)}{bc}} \div \sqrt{\frac{s(s-a)}{bc}}$$

$$\therefore \tan \frac{A}{2} = \sqrt{\frac{(s-b)(s-c)}{s(s-a)}}$$

Similarly,  $\tan \frac{B}{2} = \sqrt{\frac{(s-a)(s-c)}{s(s-b)}}$  and

$$\tan \frac{C}{2} = \sqrt{\frac{(s-a)(s-b)}{s(s-c)}}$$

**ILLUSTRATION 15:** In any triangle prove that  $(a+b+c) \left( \tan \frac{A}{2} + \tan \frac{B}{2} \right) = 2c \cot \frac{C}{2}$ .

**SOLUTION:** L.H.S =  $2s \left[ \sqrt{\frac{(s-b)(s-c)}{s(s-a)}} + \sqrt{\frac{(s-c)(s-a)}{s(s-b)}} \right] = 2s \sqrt{\frac{s-c}{s}} \left[ \sqrt{\frac{s-b}{s-a}} + \sqrt{\frac{s-a}{s-b}} \right]$

$$= 2\sqrt{s(s-c)} \left[ \frac{s-b+s-a}{\sqrt{(s-a)(s-b)}} \right] = \frac{2\sqrt{s(s-c)} \cdot c}{\sqrt{(s-a)(s-b)}} = 2c \cot \frac{C}{2}$$

This identity may also be proved by substituting for the sides.

We have,  $\frac{a+b+c}{c} = \frac{\sin A + \sin B + \sin C}{\sin C}$  (by sine rule)

$$= \frac{4 \cos \frac{A}{2} \cos \frac{B}{2} \cos \frac{C}{2}}{2 \sin \frac{C}{2} \cos \frac{C}{2}} = \frac{2 \cos \frac{A}{2} \cos \frac{B}{2}}{\sin \frac{C}{2}}$$

$$\text{Also, } = \frac{2 \cot \frac{C}{2}}{\tan \frac{A}{2} + \tan \frac{B}{2}} = \frac{2 \cos \frac{C}{2} \cos \frac{A}{2} \cos \frac{B}{2}}{\sin \frac{C}{2} \left[ \sin \frac{A}{2} \cos \frac{B}{2} + \cos \frac{A}{2} \sin \frac{B}{2} \right]} = \frac{2 \cos \frac{A}{2} \cos \frac{B}{2} \cos \frac{C}{2}}{\sin \frac{C}{2} \sin \frac{A+B}{2}} = \frac{2 \cos \frac{A}{2} \cos \frac{B}{2}}{\sin \frac{C}{2}}$$

$$\therefore \frac{a+b+c}{c} = \frac{2 \cot \frac{C}{2}}{\tan \frac{A}{2} + \tan \frac{B}{2}}, \text{ So that } (a+b+c) \left( \tan \frac{A}{2} + \tan \frac{B}{2} \right) = 2c \cot \frac{C}{2}$$

### AREA OF TRIANGLE ABC

If  $\Delta$  represents the area of a triangle  $ABC$ , then

$$\Delta = (1/2) BC \cdot AD \quad \left( \because \Delta = \frac{1}{2} (\text{base}) \times \text{height} \right)$$

$$= \frac{1}{2} a (c \sin B) \quad \left( \text{as } \sin B = \frac{AD}{c} \right) = \frac{1}{2} ac \sin B$$

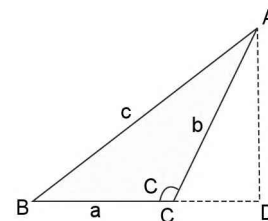
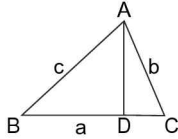

FIGURE 3.12

$$\text{Also } \sin C = \frac{AD}{b} \Rightarrow AD = b \sin C.$$

$$\therefore \Delta = \frac{1}{2} \cdot a \cdot b \sin C$$

$$\text{Similarly, } \Delta = \frac{1}{2} bc \sin A$$

**FIGURE 3.13**

$$\therefore \Delta = \frac{1}{2} ab \sin C = \frac{1}{2} bc \sin A = \frac{1}{2} ca \sin B$$

(i) *Area of a triangle in terms of sides (Heron's formula)*

$$\Delta = \frac{1}{2} bc \sin A = \frac{1}{2} bc \cdot 2 \sin \frac{A}{2} \cos \frac{A}{2}$$

$$= bc \sqrt{\frac{(s-b)(s-c)}{bc}} \sqrt{\frac{s(s-a)}{bc}}$$

$$\therefore \Delta = \sqrt{s(s-a)(s-b)(s-c)}$$

(ii) *Area of triangle in terms of one side and sine of three angles*

$$\Delta = \frac{1}{2} bc \sin A = \frac{1}{2} (k \sin B)(k \sin C) \sin A$$

$$= \frac{1}{2} k^2 \sin A \sin B \sin C = \frac{1}{2} \left( \frac{a}{\sin A} \right)^2 \sin A \sin B \sin C$$

$$= \frac{a^2}{2} \cdot \frac{\sin B \sin C}{\sin A}$$

$$\therefore \Delta = \frac{a^2}{2} \cdot \frac{\sin B \sin C}{\sin A} = \frac{b^2}{2} \cdot \frac{\sin A \sin C}{\sin B}$$

$$= \frac{c^2}{2} \cdot \frac{\sin A \sin B}{\sin C}$$

**ILLUSTRATION 16:** If  $\alpha, \beta, \gamma$  are the lengths of the altitudes of a triangle  $ABC$ , prove that

$$\alpha^{-2} + \beta^{-2} + \gamma^{-2} = \frac{(\cot A + \cot B + \cot C)}{\Delta}; \text{ where } \Delta \text{ is the area of the triangle}$$

$$\text{SOLUTION: } \Delta = \frac{1}{2} a\alpha = \frac{1}{2} b\beta = \frac{1}{2} c\gamma$$

$$\therefore \text{LHS} = \frac{a^2}{4\Delta^2} + \frac{b^2}{4\Delta^2} + \frac{c^2}{4\Delta^2} = \frac{a^2 + b^2 + c^2}{4\Delta^2} = \frac{1}{\Delta} \left( \frac{a^2 + b^2 - c^2}{4\Delta} + \frac{b^2 + c^2 - a^2}{4\Delta} + \frac{c^2 + a^2 - b^2}{4\Delta} \right)$$

$$\text{Now put } 4\Delta = 2bc \sin A = 2ac \sin B = 2ab \sin C$$

$$= \frac{1}{\Delta} \left[ \frac{a^2 + b^2 - c^2}{2ab \sin C} + \frac{b^2 + c^2 - a^2}{2bc \sin A} + \frac{c^2 + a^2 - b^2}{2ca \sin B} \right]$$

$$= \frac{1}{\Delta} \left[ \frac{\cos C}{\sin C} + \frac{\cos A}{\sin A} + \frac{\cos B}{\sin B} \right] = \frac{1}{\Delta} [\cot A + \cot B + \cot C] = R.H.S.$$

**ILLUSTRATION 17:** Prove that,  $\frac{\cot A/2 + \cot B/2 + \cot C/2}{\cot A + \cot B + \cot C} = \frac{(a+b+c)^2}{a^2 + b^2 + c^2}$

$$\text{SOLUTION: } \cot \frac{A}{2} = \frac{\sqrt{s(s-a)}}{\sqrt{(s-b)(s-c)}} \times \frac{\sqrt{s(s-a)}}{\sqrt{s(s-a)}} \quad \left( \text{Taking } \cot \frac{A}{2} = \frac{1}{\tan \frac{A}{2}} \text{ and multiplying by } \sqrt{s(s-a)} \text{ in the numerator and denominator.} \right)$$

$$\Rightarrow \cot \frac{A}{2} = \frac{s(s-a)}{\Delta}; \text{ (where } \Delta = \sqrt{s(s-a)(s-b)(s-c)} \text{),}$$

$$\text{Then } \cot \frac{A}{2} + \cot \frac{B}{2} + \cot \frac{C}{2} = \frac{s(3s - (a+b+c))}{\Delta} = \frac{s^2}{\Delta} = \frac{(a+b+c)^2}{4\Delta} \quad \dots(i)$$

$$\therefore \cot A = \frac{\cos A}{\sin A}$$

$$\Rightarrow \cot A = \frac{b^2 + c^2 - a^2}{2abck} \quad (\text{Using cosine Rule and sine rule})$$

$$\begin{aligned} \Rightarrow \cot A + \cot B + \cot C &= \frac{b^2 + c^2 - a^2}{2abck} + \frac{c^2 + a^2 - b^2}{2abck} + \frac{a^2 + b^2 - c^2}{2abck} \\ &= \frac{a^2 + b^2 + c^2}{2abck} = \frac{a^2 + b^2 + c^2}{2bc \sin A} \end{aligned}$$

$$\Rightarrow \cot A + \cot B + \cot C = \frac{a^2 + b^2 + c^2}{4\Delta}; \text{ where } \Delta = \frac{1}{2}bc \sin A \quad \dots(ii)$$

Now dividing (i) by (ii)

$$\frac{\cot \frac{A}{2} + \cot \frac{B}{2} + \cot \frac{C}{2}}{\cot A + \cot B + \cot C} = \frac{(a+b+c)^2}{a^2 + b^2 + c^2} \quad \text{Hence proved}$$

**ILLUSTRATION 18:** If points  $D, E$  and  $F$  divides sides  $BC, CA$  and  $AB$  respectively in ratio  $\lambda : 1$  (in order) and area of  $\Delta DEF$  is 40% of the total area of  $\Delta ABC$ , then find all possible values  $\lambda$ .

**SOLUTION:**

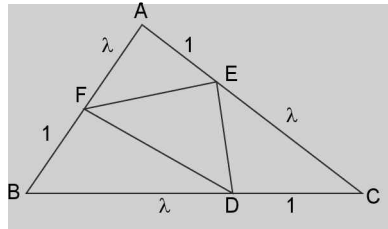

**FIGURE 3.14**

$$\text{ar } \Delta AEF = \frac{1}{2}(AF) \times (AE) \sin A = \frac{1}{2} \left( \frac{\lambda c}{\lambda + 1} \right) \left( \frac{b}{\lambda + 1} \right) \sin A = \frac{\lambda}{(\lambda + 1)^2} \left( \frac{1}{2} bc \sin A \right) = \frac{\lambda \Delta}{(\lambda + 1)^2}$$

$$\text{Similarly, ar } \Delta BDF = \frac{\lambda}{(\lambda + 1)^2} \left( \frac{1}{2} ac \sin B \right) = \frac{\lambda \Delta}{(\lambda + 1)^2}$$

$$\text{And ar } \Delta CDE = \frac{\lambda}{(\lambda + 1)^2} \left( \frac{1}{2} ab \sin C \right) = \frac{\lambda \Delta}{(\lambda + 1)^2}$$

Now, it is given that  $\text{ar } \Delta DEF = 40\% \text{ ar } \Delta ABC$

$$\Rightarrow \frac{\text{ar } \Delta DEF}{\text{ar } \Delta ABC} = \frac{2}{5}$$

$$\Rightarrow \frac{\text{ar } \Delta ABC - (\text{ar } \Delta AEF + \text{ar } \Delta BDF + \text{ar } \Delta CDE)}{\text{ar } \Delta ABC} = \frac{2}{5}$$

$$\Rightarrow \frac{\Delta - \left( \frac{3\lambda \Delta}{(\lambda + 1)^2} \right)}{\Delta} = \frac{2}{5} \quad \Rightarrow 1 - \frac{3\lambda}{(\lambda + 1)^2} = \frac{2}{5}$$

$$\begin{aligned} \Rightarrow \frac{3\lambda}{(\lambda+1)^2} &= \frac{3}{5} & \Rightarrow \frac{\lambda}{(\lambda+1)^2} &= \frac{1}{5} \\ \Rightarrow (\lambda+1)^2 &= 5\lambda & \Rightarrow \lambda^2 - 3\lambda + 1 &= 0 \\ \Rightarrow \lambda &= \frac{3 \pm \sqrt{9-4}}{2(1)} = \frac{3 \pm \sqrt{5}}{2} \\ \therefore \lambda &= \frac{3-\sqrt{5}}{2}, \frac{3+\sqrt{5}}{2} \text{ are possible values of } \lambda \end{aligned}$$

**ILLUSTRATION 19:** In  $\triangle ABC$ , M and N are mid-points of sides BC and AB respectively such that  $\angle MAC = \pi/8$  and  $\angle NCA = \pi/4$ , and  $AM = 5$ cm, then find area of  $\triangle ABC$ .

**SOLUTION:**

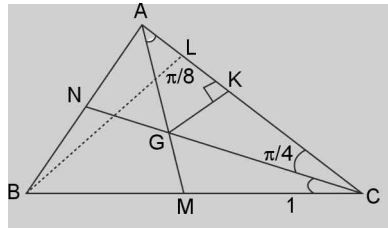

**FIGURE 3.15**

We know that centroid divides each median in the ratio 1 : 2 (1 towards side and 2 towards vertex) and hence by similarity of  $\Delta$ 's it can be proved easily that  $\perp$  rs drawn from G and B on side AC are in ratio 1 : 3.

$$\Rightarrow \frac{\text{ar } \triangle AGC}{\text{ar } \triangle ABC} = \frac{- \times AC \times GK}{- \times AC \times BL} \quad \frac{GK}{BL} = \frac{\frac{1}{3}BL}{BL} = \frac{1}{3}$$

$$\Rightarrow \text{ar } \triangle ABC = 3 \text{ar } \triangle AGC \quad \dots (i)$$

$$\text{Now ar } \triangle AGC = \frac{1}{2} AG \times GC \sin \angle AGC$$

$$= \frac{1}{2} AG \times GC \sin \left[ \pi - \left( \frac{\pi}{8} + \frac{\pi}{4} \right) \right] = \frac{1}{2} AG \times GC \sin \left( \frac{5\pi}{8} \right) \quad \dots (ii)$$

$$= \frac{1}{2} \left( \frac{2}{3} AM \right) \times \left[ \frac{AG \sin \pi/8}{\sin \pi/4} \right] \sin \left( \frac{5\pi}{8} \right)$$

$$= \frac{1}{3} (5) \times \frac{2}{3} (5) \frac{\sin \pi/8}{\sin \pi/4} \times \sin \left( \frac{5\pi}{8} \right) \quad \left[ \because \text{By sine formula } \frac{AG}{\sin \frac{\pi}{4}} = \frac{GC}{\sin \frac{\pi}{8}} \right]$$

$$= \frac{50}{9} \frac{\sin \frac{\pi}{8} \sin \left( \frac{5\pi}{8} \right)}{\sin \frac{\pi}{4}} = \frac{50}{9} \frac{\sin \frac{\pi}{8} \sin \left[ \frac{\pi}{2} + \frac{\pi}{8} \right]}{\sin \frac{\pi}{4}} = \frac{50}{9} \frac{\sin \frac{\pi}{8} \cos \frac{\pi}{8}}{\sin \frac{\pi}{4}} = \frac{50 \sin \frac{\pi}{8} \cos \frac{\pi}{8}}{18 \sin \frac{\pi}{8} \cos \frac{\pi}{8}} = \frac{25}{9}$$

$$\therefore \text{Area of } \triangle ABC = 3 \left( \frac{25}{9} \right) = \frac{25}{3}$$



■ 'm-n' THEOREM (COTANGENT THEOREM)

We have found relationship between elements of a triangle where perpendicular is drawn from vertices to the opposite sides. If instead of a perpendicular any line is drawn from a vertex to the opposite side, can we still find relation between various elements.

The expression you are looking for is called the m-n rule or cotangent theorem.

In any triangle ABC, if D is any point on the base BC such that  $BD : DC :: m : n$ ,

$\angle BAD = \alpha, \angle CAD = \beta, \angle CDA = \theta$ , then

$$(m + n) \cot \theta = m \cot \alpha - n \cot \beta = n \cot B - m \cot C.$$

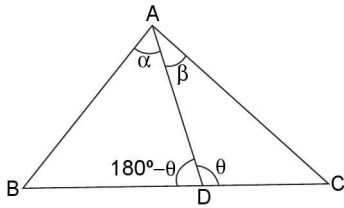

FIGURE 3.16

In  $\triangle ABD$ ,  $\frac{c}{\sin(180^\circ - \theta)} = \frac{AD}{\sin B} = \frac{BD}{\sin \alpha}$   
 (By sine formula)

$$\therefore \frac{c \sin \alpha}{\sin \theta} = BD \quad \dots (1)$$

$$\text{Similarly, } \frac{b}{\sin \theta} = \frac{CD}{\sin \beta} \Rightarrow CD = \frac{b \sin \beta}{\sin \theta} \quad \dots (2)$$

It is given that  $nBD = mDC$

$$\Rightarrow \frac{nc \sin \alpha}{\sin \theta} = \frac{mb \sin \beta}{\sin \theta}$$

$$\Rightarrow n \sin C \cdot \sin \alpha = m \sin B \sin \beta \quad \dots (3)$$

$$\Rightarrow n \sin [180^\circ - (\beta + \theta)] \sin \alpha = m \sin (\theta - \alpha) \sin \beta$$

$$\Rightarrow n \sin \alpha \sin (\beta + \theta) = m \sin (\theta - \alpha) \sin \beta$$

Dividing both sides by  $\sin \alpha \sin \beta \sin \theta$  we get,

$$n \frac{\sin(\beta + \theta)}{\sin \beta \sin \theta} = m \frac{\sin(\theta - \alpha)}{\sin \theta \sin \alpha}$$

$$\Rightarrow n(\cot \theta + \cot \beta) = m[\cot \alpha - \cot \theta]$$

$$\Rightarrow (m + n) \cot \theta = m \cot \alpha - n \cot \beta$$

Again from equation (3),

$$n \sin C \sin (\theta - B) = m \sin B \sin [180^\circ - (\theta + C)]$$

$$n \sin C \sin (\theta - B) = m \sin B \sin (\theta + C).$$

On simplifying, we get  $(m + n) \cot \theta = n \cot B - m \cot C$ .

**ILLUSTRATION 20:** The base of a triangle is divided into three equal parts. If  $t_1, t_2, t_3$  be the tangents of the angle subtended by these parts at the opposite vertices.

Prove that  $\left(\frac{1}{t_1} + \frac{1}{t_2}\right)\left(\frac{1}{t_2} + \frac{1}{t_3}\right) = 4\left(1 + \frac{1}{t_2^2}\right)$

**SOLUTION:** Let  $BD = DE = EC = x; t_1 = \tan \theta_1, t_2 = \tan \theta_2, t_3 = \tan \theta_3$

In  $\triangle ABC$ , applying  $m - n$  rule, we have

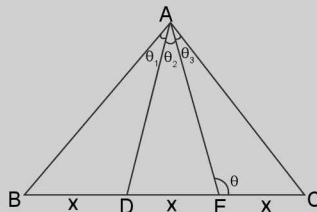

FIGURE 3.17

$$3x \cot(\theta) = 2x \cot(\theta_1 + \theta_2) - x \cot \theta_3 \quad \dots(1)$$

In  $\triangle ADC$ , applying  $m - n$  rule, we have

$$2x \cot \theta = x \cot \theta_2 - x \cot \theta_3 \quad \dots(2)$$

Dividing (1) by (2), we get  $\frac{3}{2} = \frac{2 \cot(\theta_1 + \theta_2) - \cot \theta_3}{\cot \theta_2 - \cot \theta_3}$

$$\begin{aligned}
 &\Rightarrow 3 \cot \theta_2 - 3 \cot \theta_3 = 4 \cot (\theta_1 + \theta_2) - 2 \cot \theta_3 \\
 &\Rightarrow 4 \cot (\theta_1 + \theta_2) + \cot \theta_3 - 3 \cot \theta_2 = 0 \\
 &\Rightarrow 4 \left( \frac{\cot \theta_1 \cot \theta_2 - 1}{\cot \theta_1 + \cot \theta_2} \right) - 3 \cot \theta_2 + \cot \theta_3 = 0 \\
 &\Rightarrow 4(\cot \theta_1 \cot \theta_2) - 4 - 3 \cot \theta_2 \cot \theta_1 - 3 \cot^2 \theta_2 + \cot \theta_3 \cot \theta_1 + \cot \theta_2 \cot \theta_3 = 0 \\
 &\Rightarrow \cot \theta_1 \cot \theta_2 + \cot \theta_2 \cot \theta_3 + \cot \theta_3 \cot \theta_1 + \cot^2 \theta_2 = 4(1 + \cot^2 \theta_2) \\
 &\quad \text{(Adding } 4\cot^2 \theta_2 \text{ on both sides)} \\
 &\Rightarrow (\cot \theta_1 + \cot \theta_2)(\cot \theta_2 + \cot \theta_3) = 4(1 + \cot^2 \theta_2) \\
 &\Rightarrow \left( \frac{1}{t_1} + \frac{1}{t_2} \right) \left( \frac{1}{t_2} + \frac{1}{t_3} \right) = 4 \left( 1 + \frac{1}{t_2^2} \right)
 \end{aligned}$$

**ILLUSTRATION 21:** If the median  $AM$  of a  $\triangle ABC$  subtends an angle  $3\pi/4$  with the side  $BC$ , then evaluate  $|\cot B - \cot C|$ .

**SOLUTION:**

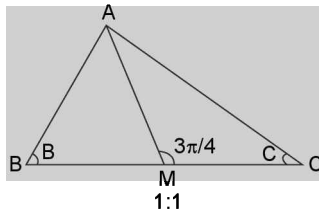

**FIGURE 3.18**

Let  $\angle AMC = 3\pi/4$  and  $M$  is the mid-point of  $BC$

$$\Rightarrow BM : MC = 1 : 1$$

$\therefore$  By cotangent theorem,  $(BM + MC) \cot \angle AMC = MC \cot B - BM \cot C$

$$\Rightarrow 2 \cot \angle AMC = \cot B - \cot C \Rightarrow 2 \cot(3\pi/4) = \cot B - \cot C$$

$$\Rightarrow -2 = \cot B - \cot C \Rightarrow |\cot B - \cot C| = 2$$

**ILLUSTRATION 22:** If in a  $\triangle ABC$ ,  $AB = 4$  cm,  $AC = 8$  cm and  $\cos\left(\frac{B-C}{2}\right) = \frac{1}{\sqrt{2}}$ ; then evaluate  $|2 \cot B - \cot C|$

**SOLUTION:** In  $\triangle ABC$ , let  $AD$  be the internal angle bisector of  $\angle A$  as shown below:

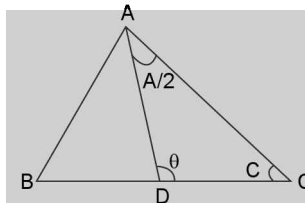

**FIGURE 3.19**

and let bisector  $AD$  subtends an angle  $\theta$  with  $BC$  as shown below. Then  $\theta = \pi - \left(\frac{A}{2} + C\right)$

$$\Rightarrow \sin \theta = \sin\left(\frac{A}{2} + C\right) = \sin\left(C + \frac{\pi}{2} - \left(\frac{B+C}{2}\right)\right) = \sin\left[\frac{\pi}{2} + \left(\frac{C}{2} - \frac{B}{2}\right)\right]$$

$$= \cos\left(\frac{C-B}{2}\right) = \cos\left(\frac{B-C}{2}\right) = \frac{1}{\sqrt{2}} \text{ (Given)}$$

$$\Rightarrow \theta = \pi/4 \text{ or } 3\pi/4$$

$$\Rightarrow \cot\theta = 1 \text{ or } -1$$

$\therefore$  By angle bisector theorem, we know that,  $BD : DC = AB : AC = 4 : 8 = 1 : 2$

$\therefore$  By 'm - n' theorem

$$\text{We have, } (DC + BD) \cot\theta = DC \cot B - BD \cot C$$

$$\Rightarrow (2 + 1) (\pm 1) = 2 \cot B - 1 \cot C$$

$$\Rightarrow \pm 3 = 2 \cot B - \cot C \Rightarrow |2 \cot B - \cot C| = 3$$

**TEXTUAL EXERCISE-2 (SUBJECTIVE)**

1. Prove that in a  $\Delta ABC$   $\frac{a+b}{a-b} = \tan \frac{A+B}{2} \cot \frac{A-B}{2}$ .
2. Consider the following statements concerning a triangle  $ABC$ :
  - (i) The sides  $a, b, c$  and area of  $\Delta$  are rational.
  - (ii)  $a, \tan A/2, \tan B/2, \tan C/2$  are rational.
  - (iii)  $a, \sin A, \sin B, \sin C$  are rational, then prove that (i)  $\Rightarrow$  (ii)  $\Rightarrow$  (iii)  $\Rightarrow$  (i)
3. (a) In a triangle  $ABC$ , if  $\cot A/2 \cot B/2 = c$ ,  $\cot B/2 \cot C/2 = a$  and  $\cot C/2 \cot A/2 = b$ , then prove that  $\frac{1}{s-a} + \frac{1}{s-b} + \frac{1}{s-c} = 2$ .  
 (b) In triangle  $ABC$ ,  $a = 18, b = 24$  and  $c = 30$ , then find  $\sin A, \sin B, \sin C$ . [without cosine Rule]
4. If  $\Delta = a^2 - (b - c)^2$ ; where  $\Delta$  is area of  $\Delta ABC$ , then show that  $\tan A = 8/15$ .
5. In a triangle  $ABC$ , if  $3a = b + c$ , prove that  $\cot B/2 \cot C/2 = 2$ .
6. In any  $\Delta ABC$ , if  $\cos\theta = \frac{a}{b+c}, \cos\phi = \frac{b}{a+c}, \cos\psi = \frac{c}{a+b}$ ; where  $\theta, \phi, \psi$  are angles of  $\Delta$ , then prove that  $\tan^2 \theta/2 + \tan^2 \phi/2 + \tan^2 \psi/2 = 1$  and hence or otherwise evaluate  $\tan \theta/2 \cdot \tan \phi/2 \cdot \tan \psi/2$ .
7. (a) In a  $\Delta ABC$ , evaluate  $\left(\frac{b-c}{a}\right) \cos^2 \frac{A}{2} + \left(\frac{c-a}{b}\right) \cos^2 \frac{B}{2} + \left(\frac{a-b}{c}\right) \cos^2 \frac{C}{2}$ .  
 (b) Prove that  $(b + c - a) (\cot B/2 + \cot C/2) = 2a \cot A/2$ .
8. If  $a, b$  and  $c$  represent the sides of a triangle  $ABC$ , and  $a, 2b, c$  are in A.P. then evaluate  $a \cos^2 C/2 + c \cos^2 A/2$  in terms of  $b$ .

9. If  $A$  is the area and  $2s$  the sum of the sides of a  $\Delta$ , then show that  
 (a)  $A \leq \frac{s^2}{3\sqrt{3}}$                       (b)  $A < \frac{s^2}{4}$
10. If  $a, b, c$  are in H.P., then prove that  $\sin^2 A/2, \sin^2 B/2, \sin^2 C/2$  are also in H.P.
11. In a triangle  $ABC$ , if  $\tan (A/2) = 5/36$  and  $\tan (B/2) = 12/5$ , then prove that the sides  $a, c, b$  of the triangle are in A.P.
12. If  $p_1, p_2, p_3$  are the altitudes of a triangle and  $\Delta$  be the area, then prove that  $\frac{1}{p_1} + \frac{1}{p_2} - \frac{1}{p_3} = \frac{(s-c)}{\Delta} = \frac{2ab}{(a+b+c)\Delta} \cos^2 \frac{C}{2}$
13. In a  $\Delta PQR$ ,  $PL$  and  $QM$  are the medians. If  $PL = 6$  cm.  $\angle QPL = \pi/6$  and  $\angle PQM = \pi/3$ , then show that area of  $\Delta PQR = 8\sqrt{3}$  cm<sup>2</sup>.
14. In any  $\Delta ABC$ , prove that  $a \sin A + b \sin B + c \sin C = \sqrt{a^2 + b^2 + c^2} \cdot \sqrt{\sin^2 A + \sin^2 B + \sin^2 C}$ .
15. In a triangle  $ABC$ , prove that  $a \sin(A/2 + B) = (b + c) \sin A/2$ .
16. (i) Find the value of  $\theta$  in the given figure.

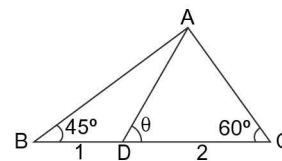

**FIGURE 3.20**

- (ii) Evaluate  $m + n$  in the given diagram if  $m : n$  is ratio in lowest form.

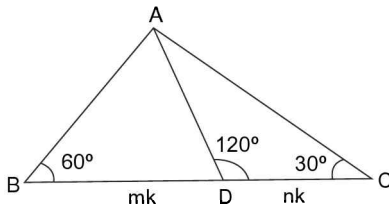
**FIGURE 3.21**

(iii) If the median of  $\triangle ABC$  through  $A$  is perpendicular to  $AB$ . Then prove that  $\tan A + 2 \tan B = 0$ .

17. The upper  $\left(\frac{3}{4}\right)^{\text{th}}$  portion of a vertical pole subtends an angle of  $\tan^{-1}\left(\frac{3}{5}\right)$  at a point in the horizontal plane through its foot and at a distance of 40 m from the foot. Find the height of the vertical pole.
18. Given a  $\triangle ABC$  with angle  $\angle A = 60^\circ$  and sides  $b$  and  $c$  are 3,  $2\sqrt{3}$  respectively. If  $D$  is a point on  $BC$  such that  $AD$  is internal angle bisector of  $\angle A$ , find the value of angle  $\theta$  and length of angle bisector  $AD$ .

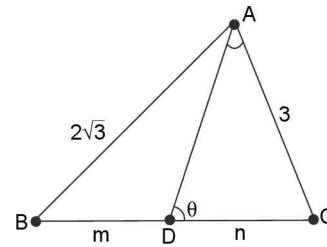
**FIGURE 3.22**

19. If in a triangle  $ABC$ ,  $A = 30^\circ$  and the area of  $\Delta$  is  $\frac{\sqrt{3}a^2}{4}$ , then prove that  $B = 4C$  or  $C = 4B$ .
20. In a triangle  $PQR$ , the median of side  $QR$  is of length  $\sqrt{\frac{7+5\sqrt{3}}{13}}$  and it divides angle  $P$  into angles of  $30^\circ$  and  $45^\circ$ . Find the length of side  $QR$ .
21. Two sides of a triangle are given by the roots of the equation  $x^2 - 2\sqrt{3}x + 2 = 0$ . The angle between the sides is  $\pi/3$ . Find the perimeter of triangle.

## Answer Keys

3. (b)  $\sin A = 3/5$ ,  $\sin B = 4/5$ ,  $\sin C = 1$       6.  $\frac{1}{3\sqrt{3}}$       7. (a) zero      8.  $5b/2$
16. (i)  $\left(\frac{2\sqrt{3}-1}{3\sqrt{3}}\right)$       (ii) 2      17. 160/9 m      18.  $\cot^{-1}\left(\frac{2\sqrt{3}-3}{2+\sqrt{3}}\right)$ ,  $\frac{6\sqrt{3}}{2+\sqrt{3}}$       20. 2      21.  $2\sqrt{3} + \sqrt{6}$

## TEXTUAL EXERCISE-2 (OBJECTIVE)

1. If in a triangle  $ABC$ ,  $(s-a)(s-b) = s(s-c)$ , then angle  $C$  is equal to  
 (a)  $90^\circ$       (b)  $45^\circ$   
 (c)  $30^\circ$       (d)  $60^\circ$
2. If in a  $\triangle ABC$ ,  $2s = a + b + c$  and  $(s-b)(s-c) = x \sin^2 \frac{A}{2}$ , then  $x =$   
 (a)  $bc$       (b)  $ca$   
 (c)  $ab$       (d)  $abc$
3. In triangle  $ABC$ ,  $(b+c)\cos A + (c+a)\cos B + (a+b)\cos C =$   
 (a) 0      (b) 1  
 (c)  $a+b+c$       (d)  $2(a+b+c)$
4. In  $\triangle ABC$ , if  $a = 16$ ,  $b = 24$  and  $c = 20$ , then  $\cos \frac{B}{2}$  is equal to  
 (a)  $3/4$       (b)  $1/4$   
 (c)  $1/2$       (d)  $1/3$
5. In  $\triangle ABC$ ,  $1 - \tan \frac{A}{2} \tan \frac{B}{2}$  is equal to  
 (a)  $\frac{2c}{a+b+c}$       (b)  $\frac{2a}{a+b+c}$   
 (c)  $\frac{2}{a+b+c}$       (d)  $\frac{4a}{a+b+c}$
6. In  $\triangle ABC$ , if  $\tan \frac{A}{2} \tan \frac{C}{2} = \frac{1}{2}$ , then  $a, b, c$  are in  
 (a) A. P.      (b) G. P.  
 (c) H. P.      (d) None of these

3.20 > Trigonometry

7. In triangle  $ABC$  if  $a, b, c$  are in A. P. then the value of

$$\frac{\sin \frac{A}{2} \sin \frac{C}{2}}{\sin \frac{B}{2}}$$
 is equal to

- (a) 1 (b)  $1/2$   
(c) 2 (d)  $-1$

8. If  $\tan \frac{B-C}{2} = x \cot \frac{A}{2}$ , then  $x =$

- (a)  $\frac{c-a}{c+a}$  (b)  $\frac{a-b}{a+b}$   
(c)  $\frac{b-c}{b+c}$  (d) None of these

9. If in a triangle,  $a \cos^2 \frac{C}{2} + c \cos^2 \frac{A}{2} = \frac{3b}{2}$ , then its sides will be in

- (a) A. P. (b) G. P.  
(c) H. P. (d) A. G.

10.  $\cot \left( \frac{A+B}{2} \right) \tan \left( \frac{A-B}{2} \right)$  is equal to

- (a)  $\frac{a+b}{a-b}$  (b)  $\frac{a-b}{a+b}$   
(c)  $\frac{a}{a+b}$  (d) None of these

11. In a  $\Delta ABC$ , if  $A = 30^\circ, b = 2, c = \sqrt{3} + 1$ , then  $\frac{C-B}{2}$  is equal to

- (a)  $15^\circ$  (b)  $30^\circ$   
(c)  $45^\circ$  (d) None of these

12. In any triangle  $ABC$ ,  $\frac{\tan \frac{A}{2} - \tan \frac{B}{2}}{\tan \frac{A}{2} + \tan \frac{B}{2}} =$

- (a)  $\frac{a-b}{a+b}$  (b)  $\frac{a-b}{c}$   
(c)  $\frac{a-b}{a+b+c}$  (d)  $\frac{c}{a+b}$

13. In a  $\Delta ABC$ ,  $2ac \sin \left( \frac{A-B+C}{2} \right)$  is equal to

- (a)  $a^2 + b^2 - c^2$  (b)  $c^2 + a^2 - b^2$   
(c)  $b^2 - c^2 - a^2$  (d)  $c^2 - a^2 - b^2$

14. In  $\Delta ABC$ , if  $2s = a + b + c$ , then the value of  $\frac{s(s-a)}{bc} - \frac{(s-b)(s-c)}{bc} =$

- (a)  $\sin A$  (b)  $\cos A$   
(c)  $\tan A$  (d) None of these

15. In a  $\Delta ABC$ ,  $\frac{c+b}{c-b} \cdot \tan \frac{A}{2}$  is equal to

- (a)  $\tan \left( \frac{A}{2} + B \right)$  (b)  $\cot \left( \frac{A}{2} + B \right)$   
(c)  $\tan \left( A + \frac{B}{2} \right)$  (d) none of these

16. In a  $\Delta ABC$ ,  $\cot \frac{A-B}{2} \cdot \cot \frac{C}{2}$  is equal to

- (a)  $\frac{a+b}{a-b}$  (b)  $\frac{a-b}{a+b}$   
(c)  $\frac{a(a-b)}{b(a+b)}$  (d) none of these

17. If in a triangle  $ABC$ ,  $\angle B = 90^\circ$ , then  $\tan^2 \left( \frac{A}{2} \right)$  is

- (a)  $\frac{b-c}{b+c}$  (b)  $\frac{b+c}{b-c}$   
(c)  $\frac{b-2c}{b+c}$  (d) none of these

18. If in a triangle  $ABC$  side  $a = (\sqrt{3} + 1)$  cm and  $\angle B = 30^\circ, \angle C = 45^\circ$ , then the area of the triangle is

- (a)  $\frac{\sqrt{3}+1}{3} \text{ cm}^2$  (b)  $\frac{\sqrt{3}+1}{2} \text{ cm}^2$   
(c)  $\frac{\sqrt{3}+1}{2\sqrt{2}} \text{ cm}^2$  (d)  $\frac{\sqrt{3}+1}{3\sqrt{2}} \text{ cm}^2$

19. If the area of a triangle  $ABC$  is  $\Delta$ , then  $a^2 \sin 2B + b^2 \sin 2A$  is equal to

- (a)  $3\Delta$  (b)  $2\Delta$   
(c)  $4\Delta$  (d) None of these

20. In a triangle  $ABC$ , if  $\frac{\cos A}{a} = \frac{\cos B}{b} = \frac{\cos C}{c}$  and the sides  $a = 2$ , then area of triangle is

- (a) 1 (b) 2  
(c)  $3\sqrt{2}$  (d)  $\sqrt{3}$

21. If  $c^2 = a^2 + b^2, 2s = a + b + c$ , then  $4s(s-a)(s-b)(s-c)$  is equal to

- (a)  $s^4$  (b)  $b^2 c^2$   
(c)  $c^2 a^2$  (d)  $a^2 b^2$

22. If  $R$  is the radius of the circumcircle of  $\Delta ABC$ , and  $\Delta$  is its area, then:

- (a)  $R = \frac{a+b+c}{\Delta}$  (b)  $R = \frac{a+b+c}{4\Delta}$   
(c)  $R = \frac{abc}{4\Delta}$  (d)  $R = \frac{abc}{\Delta}$

23. If the median  $AD$  of a  $\triangle ABC$ , makes an angle  $\theta$  with the side  $AB$ , then  $\sin(A - \theta)$  is equal to  
 (a)  $(b/c)\operatorname{cosec} \theta$       (b)  $(b/c)\sin \theta$   
 (c)  $(c/b)\sin \theta$       (d)  $(c/b)\operatorname{cosec} \theta$
24. If the bisector of angle  $A$  of triangle  $ABC$  makes an angle  $\theta$  with  $BC$ , then  $\sin \theta$  is equal to  
 (a)  $\cos(B - C)/2$       (b)  $\sin(B - C)/2$   
 (c)  $\sin(B - A)/2$       (d) None of these

## Answer Keys

1. (a)    2. (a)    3. (c)    4. (a)    5. (a)    6. (d)    7. (b)    8. (c)    9. (a)    10. (b)  
 11. (b)    12. (b)    13. (b)    14. (b)    15. (a)    16. (a)    17. (a)    18. (b)    19. (c)    20. (d)  
 21. (d)    22. (c)    23. (c)    24. (a)

### SOLUTION OF TRIANGLE

In a triangle, there are six elements or parts, three sides and three angles. If three of the elements are given, at least one of which must be a side, then the other three elements can be determined uniquely.

If the three angles alone are given, then it is clear from the formula  $\frac{a}{\sin A} = \frac{b}{\sin B} = \frac{c}{\sin C}$ , only ratios of the sides can be determined not their actual lengths. Thus the triangle cannot be uniquely solved. In such a case, there exists an infinite number of equiangular triangles all satisfying the given data. The method of determining the unknown parts from the known parts is called solving triangle and the unknown parts thus determined are called solution of triangle.

#### Case 1: When three sides of triangle are given:

In this case, the following formulae are generally used:

- (i)  $\sin \frac{A}{2} = \sqrt{\frac{(s-b)(s-c)}{bc}}$ ,  
 (ii)  $\cos \frac{A}{2} = \sqrt{\frac{s(s-a)}{bc}}$   
 (iii)  $\tan \frac{A}{2} = \sqrt{\frac{(s-b)(s-c)}{s(s-a)}}$   
 (iv)  $\cos A = \frac{b^2 + c^2 - a^2}{2bc}$ .

i.e., we use half angle formula or cosine formulae.

#### Case 2: When two sides and the included angle of the triangle are given:

Let  $b$ ,  $c$  and  $A$  be given, then 'a' can be found from the formula  $a^2 = b^2 + c^2 - 2bc \cos A$ .

Now angle  $B$  can be found from the formulae

$$\cos B = \frac{c^2 + a^2 - b^2}{2ac} \quad \text{or} \quad \sin B = \frac{b \sin A}{a} \quad \text{and } C \text{ from}$$

$$C = 180^\circ - A - B.$$

Another way to solve such triangle is, first to find  $\frac{B-C}{2}$  by using the formulae  $\tan\left(\frac{B-C}{2}\right) = \frac{b-c}{b+c} \cot \frac{A}{2}$  and  $\frac{B+C}{2} \left(= 90^\circ - \frac{A}{2}\right)$  and therefore by addition and subtraction  $B$  and  $C$  and the third side 'a' by  $a = \frac{b \sin A}{\sin B}$ .

#### Case 3: When two angles and included side of a triangle are given:

Let angle  $B$ ,  $C$  and side  $a$  be given. The angle  $A$  can be found from  $A = 180^\circ - B - C$  and the sides  $b$  and  $c$  from,

$$\text{sine rule } \frac{a}{\sin A} = \frac{b}{\sin B} = \frac{c}{\sin C}$$

$$\text{i.e., } b = \frac{a \sin B}{\sin A} \quad \text{and} \quad c = \frac{a \sin C}{\sin A}$$

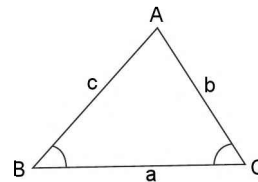

FIGURE 3.23

When an angle of a triangle is obtained with the help of sine rule, there may be ambiguity, since the sines of supplementary angles are equal in magnitude and are of the same sign, so that there are two angles less than  $180^\circ$  which have the same sine. When an angle is obtained through cosine formula, there is no ambiguity, since there is only one angle less than  $180^\circ$  whose cosine is equal to a given quantity.

$$\text{e.g., } \sin A = \frac{\sqrt{3}}{2} \Rightarrow A = 60^\circ \text{ or } 120^\circ$$

#### Case 4: Ambiguous case

When two sides  $a$  and  $b$  and the angle  $A$  opposite to one side  $a$  are given. There are three possibilities, either there is no such triangle or one triangle or two triangles which have the same given elements.

### 3.22 > Trigonometry

We have  $\frac{b}{\sin B} = \frac{a}{\sin A} \Rightarrow \sin B = \frac{b \sin A}{a}$  .... (i)

Also from cosine formula  $c^2 - 2(b \cos A) \cdot c + b^2 - a^2 = 0$  .... (ii)

gives  $c = b \cos A \pm \sqrt{a^2 - b^2 \sin^2 A}$  ... (iii)

Now, the following cases may rise

- (a) When  $a < b \sin A \Rightarrow \sin B > 1$  or from (iii)  $c$  is imaginary which is impossible. Hence no triangle is possible.

- (b) When  $b \sin A = a \Rightarrow$  from equation (i)

$\sin B = 1 \therefore B = 90^\circ$

and from equation (iii)  $c = b \cos A$ .

This value of  $c$  is admissible only when  $b \cos A$  is positive i.e., when the angle  $A$  is acute. In such case  $a < b$

( $\because b \sin A = a$ ) or  $A < B$ .

Hence only one definite triangle is possible.

#### NOTE

In this case  $a = b$  is not possible since  $A = B = 90^\circ$  which is not possible since no triangle can have two right angles.

- (c) When  $b \sin A < a$  and  $\sin B < 1$ . In this case, there are three possibilities:

(i) If  $a = b$ , then  $A = B$  and from equation (3), we get  $c = 2b \cos A$  or 0. Hence in this case we get only one triangle (since in this case it is must that  $A$  and  $B$  are acute angles).

(ii) If  $a < b$  then  $A < B$ , therefore  $A$  must be an acute angle.  $\therefore b \cos A > 0$  Further,  $a^2 < b^2$ .

$\Rightarrow a^2 < b^2 (\cos^2 A + \sin^2 A)$

$\Rightarrow \sqrt{a^2 - b^2 \sin^2 A} < b \cos A$ .

From equation (iii) it is clear that both values of  $c$  are positive so we get two triangles such that

$c_1 = b \cos A + \sqrt{a^2 - b^2 \sin^2 A}$  and

$c_2 = b \cos A - \sqrt{a^2 - b^2 \sin^2 A}$ .

It is also clear from equation (i) that there are two values of  $B$  which are supplementary.

(iii) If  $a > b$ , then  $A > B$  also  $a^2 - b^2 \sin^2 A > b^2 \cos^2 A$

or  $\sqrt{a^2 - b^2 \sin^2 A} > b \cos A$ .

Hence one value of  $c$  is positive and other negative for any value of angle  $A$ . Therefore we get only one solution.

Since, for given values of  $a$ ,  $b$  and  $A$ , there is a doubt or ambiguity in the determination of the triangle. Hence this case is called ambiguous case of the solution of triangles.

$\therefore CD = b \sin A$ . The following cases may arise:

- (a) If  $a < b \sin A$  i.e.,  $a < CD$  then the circle will not meet  $AX$  and hence there is no triangle satisfying the given condition.

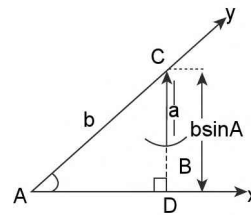

FIGURE 3.24

- (b) If  $a = b \sin A$ , the circle will touch  $AX$  at  $D$  (or  $B$ ) and only one right angled triangle is possible. In this case,  $B = 90^\circ$  and  $A < 90^\circ$

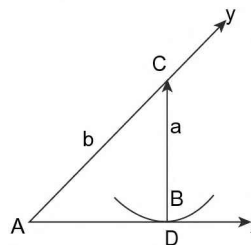

FIGURE 3.25

- (c) If  $a = b$ , then the circle will cut  $AX$  at  $B$  and passes through  $A$ . Hence we get only one solution of given data (as shown in figure).

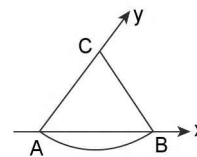

FIGURE 3.26

#### GEOMETRICAL DISCUSSION

Let  $a$ ,  $b$  and the angle  $A$  be given. Draw a line  $AX$ . At  $A$  construct angle  $\angle XAY = A$ . Cut a segment  $AC = b$  from  $AY$ . Now describe a circle with centre  $C$  and radius  $a$ . Also draw  $CD$  perpendicular to  $AX$ .

(d) If  $a > b \sin A$ , then the circle will cut  $AX$  at two distinct points (other than  $A$ ). Let the points be  $B_1$  and  $B_2$ .

**Case (i):** If  $b \sin A < a < b$ , then both  $B_1$  and  $B_2$  are on the same side of  $A$  as shown in figure and we get two distinct triangles  $ACB_1$  and  $ACB_2$ .

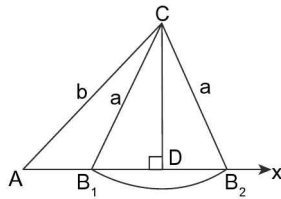

FIGURE 3.27

**Case (ii):** If  $a > b$ , then the two points  $B_1$  and  $B_2$  on the opposite sides of  $A$  and only one of the triangle  $ACB_1$  or  $ACB_2$  will satisfy the given data. If  $A$  is an acute angle, then  $\Delta CAB_2$  is the required triangle and if  $A$  is obtuse angle, then  $\Delta AB_1C$  is the required triangle.

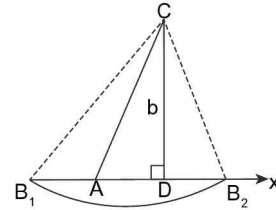

FIGURE 3.28

**ILLUSTRATION 23:** In any  $\Delta ABC$ , the sides are 6 cm, 10 cm, and 14 cm. Show that the triangle is obtuse-angled with the obtuse angle equal to  $120^\circ$ .

**SOLUTION:** Let  $a = 14$ ,  $b = 10$ ,  $c = 6$  cm.

As we know largest angle is opposite to the largest side,

$$\therefore \cos A = \frac{b^2 + c^2 - a^2}{2bc} = \frac{100 + 36 - 196}{2(10)(6)} = -\frac{1}{2} \Rightarrow A = 120^\circ.$$

**ILLUSTRATION 24:** If  $a$ ,  $b$  and  $A$  are given in a triangle and  $c_1$ ,  $c_2$  are the possible values of the third side, prove that:  $c_1^2 + c_2^2 - 2c_1c_2 \cos 2A = 4a^2 \cos^2 A$ .

**SOLUTION:**  $\cos A = \frac{b^2 + c^2 - a^2}{2bc}$

$$\Rightarrow c^2 - 2bc \cos A + b^2 - a^2 = 0, \text{ which is quadratic in 'c'.$$

$$\therefore \left. \begin{array}{l} c_1 + c_2 = 2b \cos A \\ \text{and } c_1 c_2 = b^2 - a^2 \end{array} \right\} \dots(i)$$

$$\begin{aligned} \therefore c_1^2 + c_2^2 - 2c_1c_2 \cos 2A &= (c_1 + c_2)^2 - 2c_1c_2 - 2c_1c_2 \cos 2A && \text{[using (i)]} \\ &= (c_1 + c_2)^2 - 2c_1c_2(1 + \cos 2A) \\ &= 4b^2 \cos^2 A - 2(b^2 - a^2) \cdot 2\cos^2 A = 4a^2 \cos^2 A \end{aligned}$$

$$\therefore c_1^2 + c_2^2 - 2c_1c_2 \cos A = 4a^2 \cos^2 A$$

**ILLUSTRATION 25:** In  $\Delta ABC$ ;  $b$ ,  $c$ ,  $B$  ( $c > b$ ) are given. Find condition for the third side to be real. If the third side

has, two values  $a_1$  and  $a_2$  such that  $a_1 = 3a_2$ , show that  $\sin B = \sqrt{\frac{4b^2 - c^2}{3c^2}}$ .

**SOLUTION:** We know,  $\cos B = \frac{a^2 + c^2 - b^2}{2ac} \Rightarrow a^2 - 2ac \cos B + c^2 - b^2 = 0$

$$\Rightarrow \text{For } a \text{ to be real } 4c^2 \cos^2 B - 4(c^2 - b^2) \geq 0$$

$$\Rightarrow c^2 \cos^2 B \geq (c^2 - b^2)$$

$$\Rightarrow \cos^2 B \geq \frac{(c^2 - b^2)}{c^2} \dots\dots(i)$$



$$\Rightarrow \cos B \notin \left( -\sqrt{1-\frac{b^2}{c^2}}, \sqrt{1-\frac{b^2}{c^2}} \right)$$

$$\Rightarrow B \notin \left( \cos^{-1} \sqrt{1-\frac{b^2}{c^2}}, \pi - \cos^{-1} \sqrt{1-\frac{b^2}{c^2}} \right)$$

$$B \in \left( 0, \cos^{-1} \sqrt{1-\frac{b^2}{c^2}} \right] \cup \left[ \pi - \cos^{-1} \sqrt{1-\frac{b^2}{c^2}}, \pi \right)$$

which is the required condition for the third side to be real. If  $a_1, a_2$  are two roots, then

$$a_1 + a_2 = 2c \cos B \quad \dots\dots(i)$$

$$\text{and } a_1 a_2 = c^2 - b^2 \quad \dots\dots(ii)$$

We are given  $a_1 = 3a_2$ , substituting in (i), we get,

$$4a_2 = 2c \cos B$$

$$\Rightarrow a_2 = \frac{c \cos B}{2}$$

$$\therefore a_1 = \frac{3c \cos B}{2}$$

$$\text{Hence (ii) become } \frac{3c^2 \cos^2 B}{4} = c^2 - b^2$$

$$3c^2 \cos^2 B - 4c^2 = -4b^2 \text{ or } \sin B = \sqrt{\frac{4b^2 - c^2}{3c^2}} \quad (\because \sin \theta > 0 \text{ for any angle } \theta \text{ of every } \Delta)$$

**ILLUSTRATION 26:** Find the angles of the triangles whose sides are:  $3 + \sqrt{3}, 2\sqrt{3}, \sqrt{6}$ .

**SOLUTION:** Let  $a = 3 + \sqrt{3}, b = 2\sqrt{3}, c = \sqrt{6}$

$$\Rightarrow \cos A = \frac{b^2 + c^2 - a^2}{2bc} = \frac{12 + 6 - (9 + 3 + 6\sqrt{3})}{12\sqrt{2}} = \frac{6 - 6\sqrt{3}}{12\sqrt{2}} = \frac{1 - \sqrt{3}}{2\sqrt{2}}$$

$$\Rightarrow \cos A = \cos(60^\circ + 45^\circ) \left\{ \text{as } \cos(60^\circ + 45^\circ) = \frac{1 - \sqrt{3}}{2\sqrt{2}} \right\}$$

$$\therefore A = 105^\circ$$

$$\text{Applying sine formula: } \frac{a}{\sin A} = \frac{b}{\sin B}$$

$$\Rightarrow \sin B = \frac{b}{a} \sin A = \frac{2\sqrt{3}}{3 + \sqrt{3}} \sin(105^\circ) = \frac{2\sqrt{3}}{3 + \sqrt{3}} \{ \sin 60^\circ \cdot \cos 45^\circ + \cos 60^\circ \cdot \sin 45^\circ \}$$

$$= \frac{2\sqrt{3}}{\sqrt{3}(\sqrt{3} + 1)} \left\{ \frac{\sqrt{3} + 1}{2\sqrt{2}} \right\}$$

$$\Rightarrow \sin B = \frac{1}{\sqrt{2}} = \sin 45^\circ \{ \because B \neq 180^\circ - 45^\circ \text{ as } B + A < 180^\circ \}$$

$$\Rightarrow B = 45^\circ$$

$$\text{Here, } A = 105^\circ, B = 45^\circ$$

$$\Rightarrow C = 180^\circ - (A + B) = 180^\circ - (150^\circ) = 30^\circ$$

$$\therefore \angle A = 105^\circ, \angle B = 45^\circ, \angle C = 30^\circ$$

**ILLUSTRATION 27:** The sides of a triangle are 8 cm, 10 cm and 12 cm. Prove that the greatest angle is double of the smallest angle.

**SOLUTION:** Let  $a = 8$  cm,  $b = 10$  cm and  $c = 12$  cm. Hence greatest angle is  $C$  and the smallest angle is  $A$ , {as we know greatest angle is opposite to greatest side and smallest angle is opposite to smallest side.}

Here, we have to prove  $C = 2A$ , applying cosine law, we get.

$$\cos C = \frac{a^2 + b^2 - c^2}{2ab} = \frac{64 + 100 - 144}{2 \cdot 8 \cdot 10} = \frac{1}{8} \quad \dots(i)$$

$$\text{and } \cos A = \frac{b^2 + c^2 - a^2}{2bc} = \frac{100 + 144 - 64}{2 \cdot 10 \cdot 12} = \frac{3}{4} \quad \dots(ii)$$

$$\cos 2A = 2 \cos^2 A - 1 = 2 \cdot \frac{9}{16} - 1 \quad \text{(using (ii))}$$

$$\therefore \cos 2A = \frac{1}{8} \quad \dots(iii)$$

from (i) and (iii), we get  $\cos 2A = \cos C \Rightarrow C = 2A$

**ILLUSTRATION 28:** With usual notations, if in a triangle  $ABC$ ,  $\frac{b+c}{11} = \frac{c+a}{12} = \frac{a+b}{13}$ , then prove that:

$$\frac{\cos A}{7} = \frac{\cos B}{19} = \frac{\cos C}{25}$$

**SOLUTION:** Let,  $\frac{b+c}{11} = \frac{c+a}{12} = \frac{a+b}{13} = k$  (say)

$$\Rightarrow 2(a+b+c) = 36k \quad \dots(i)$$

$$b+c = 11k, c+a = 12k, a+b = 13k \quad \dots(ii)$$

Solving (i) and (ii), we get  $a = 7k, b = 6k, c = 5k$

$$\text{Hence, } \cos A = \frac{b^2 + c^2 - a^2}{2bc} = \frac{36k^2 + 25k^2 - 49k^2}{60k^2} = \frac{12}{60} = \frac{1}{5} = \frac{7}{35}$$

$$\cos B = \frac{a^2 + c^2 - b^2}{2ac} = \frac{25k^2 + 49k^2 - 36k^2}{70k^2} = \frac{38}{70} = \frac{19}{35}$$

$$\cos C = \frac{a^2 + b^2 - c^2}{2ab} = \frac{49k^2 + 36k^2 - 25k^2}{84k^2} = \frac{60}{84} = \frac{5}{7} = \frac{25}{35}$$

$$\Rightarrow \frac{\cos A}{7} = \frac{\cos B}{19} = \frac{\cos C}{25}$$

**ILLUSTRATION 29:** Let  $O$  be a point inside a triangle  $ABC$ , such that  $\angle OAB = \angle OBC = \angle OCA = \omega$ . Then show that:  $\cot \omega = \cot A + \cot B + \cot C$ .

**SOLUTION:** In  $\triangle OAC$ , we have from sine law,  $\frac{\sin(A-\omega)}{OC} = \frac{\sin(180^\circ - A)}{b}$

$$(\because \angle AOC = 180^\circ - \angle OAC - \angle OCA = 180^\circ - (A - \omega) - \omega = 180^\circ - A)$$

$$\Rightarrow \frac{\sin(A-\omega)}{OC} = \frac{\sin A}{b} \quad \dots(i)$$

$$\text{Also in } \triangle OBC, \frac{\sin \omega}{OC} = \frac{\sin(180^\circ - C)}{a}$$

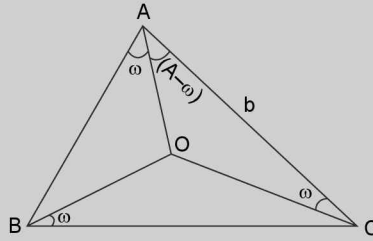

FIGURE 3.29

$$\Rightarrow \frac{\sin \omega}{OC} = \frac{\sin C}{a} \quad \dots(ii)$$

Dividing (i) by (ii), we get,  $\frac{\sin(A-\omega)}{\sin \omega} = \frac{a \sin A}{b \sin C}$

$$\Rightarrow \frac{\sin(A-\omega)}{\sin \omega} = \frac{k \sin A \cdot \sin A}{k \sin B \cdot \sin C} \quad \left\{ \text{as we know, } \frac{a}{\sin A} = \frac{b}{\sin B} = \frac{c}{\sin C} = k \right\}$$

$$\Rightarrow \frac{\sin A \cos \omega - \cos A \sin \omega}{\sin \omega} = \sin A \frac{\{\sin \pi - (B+C)\}}{\sin B \sin C}$$

$$\Rightarrow \sin A \cot \omega - \cos A = \sin A \left( \frac{\sin B \cos C + \cos B \sin C}{\sin B \sin C} \right)$$

$$\Rightarrow \sin A \cot \omega - \cos A = \sin A (\cot C + \cot B)$$

Dividing by  $\sin A$  on both sides, we get

$$\Rightarrow \cot \omega - \cot A = \cot B + \cot C \text{ or } \cot \omega = \cot A + \cot B + \cot C.$$

### TEXTUAL EXERCISE-3 (SUBJECTIVE)

1. (a) Solve the triangle  $ABC$  if
  - (i)  $\angle A = 105^\circ$ ,  $\angle C = 60^\circ$ ,  $b = 4$
  - (ii)  $\angle C = 60^\circ$ ,  $b = 4$ ,  $c = 4\sqrt{3}$
  - (iii)  $a = 2$ ,  $b = 4$  and  $\angle C = 60^\circ$ , then find  $\angle A$  and  $\angle B$ .
- (b) Given  $a = \sqrt{3}$ ,  $b = \sqrt{2}$ , and  $c = \frac{\sqrt{6} + \sqrt{2}}{2}$ , find the angles.
- (c) If  $\angle A = 60^\circ$ ,  $a = 5$ ,  $b = 2\sqrt{3}$  in  $\triangle ABC$ , then find angle  $B$ .
2.  $a = 2b$  and  $|A - B| = \pi/3$ , then determine the angle  $C$ .
3. If in a  $\triangle ABC$ ,  $\cos 3A + \cos 3B + \cos 3C = 1$ , then find the obtuse angle.
4.  $ABC$  is a triangle such that  $\sin(2A + B) = \sin(C - A) = -\sin(B + 2C) = \frac{1}{2}$ . If  $A$ ,  $B$  and  $C$  are in A. P., then find the angles of triangle.
5. If in a  $\triangle ABC$ ,  $\angle A = 45^\circ$ ,  $\angle C = 60^\circ$ , then prove that  $a + c\sqrt{2} = 2b$ .
6. Find the number of triangles  $ABC$  that can be formed with  $a = 3$ ,  $b = 8$  and  $\sin A = \frac{5}{13}$ .
7. In a right triangle  $AC = BC$  and  $D$  is the mid-point of  $AC$ . Find the cotangent of angle  $DBC$ .
8. If  $a$ ,  $b$  and  $c$  are the sides of a triangle such that  $a^4 + b^4 + c^4 = 2c^2(a^2 + b^2)$ , then find the possible angles opposite to the side  $c$ .
9. In  $\triangle ABC$ ,  $a = 5$ ,  $b = 4$ , and  $\cos(A - B) = \frac{31}{32}$ , then find side  $c$ .
10. In a  $\triangle ABC$ , if  $\tan \frac{A}{2} = \frac{5}{6}$  and  $\tan \frac{B}{2} = \frac{20}{37}$ , then prove that  $a > b > c$ .
11. In  $\triangle ABC$ , prove that 
$$\frac{(a+b+c)(b+c-a)(c+a-b)(a+b-c)}{4b^2c^2} = \sin^2 A$$

## Answer Keys

1. (a) (i)  $B : 15^\circ$ ,  $c = 2\sqrt{6}(\sqrt{3} + 1)$ ,  $a = 4(2 + \sqrt{3})$  (ii)  $\angle A = 90^\circ$ ,  $\angle B = 30^\circ$ ,  $a = 8$  (iii)  $30^\circ$ ,  $90^\circ$   
 (b)  $\angle A = 60^\circ$ ,  $\angle B = 45^\circ$ ,  $\angle C = 75^\circ$  (c)  $\sin^{-1}\left(\frac{3}{5}\right)$  2.  $C = \pi/3$  3.  $120^\circ$  4.  $45^\circ$ ,  $60^\circ$ ,  $75^\circ$   
 6. 0 7. 2 8.  $45^\circ$  or  $135^\circ$  9. 6

## TEXTUAL EXERCISE-3 (OBJECTIVE)

1. If in the  $\triangle ABC$ ,  $AB = 2BC$ , then  $\tan \frac{B}{2} : \cot \left( \frac{C-A}{2} \right)$   
 (a) 3 : 1 (b) 2 : 1  
 (c) 1 : 2 (d) 1 : 3
2. In a  $\triangle ABC$ ,  $A : B : C = 3 : 5 : 4$ . Then  $[a + b + c\sqrt{2}]$  is equal to  
 (a)  $2b$  (b)  $2c$   
 (c)  $3b$  (d)  $3a$
3. If the angles of a triangle are in the ratio 4:1:1, then the ratio of the longest side to the perimeter is  
 (a)  $\sqrt{3} : (2 + \sqrt{3})$  (b) 1 : 6  
 (c)  $1 : (2 + \sqrt{3})$  (d) 2 : 3
4. Let  $D$  be the middle point of the side  $BC$  of a triangle  $ABC$  such that  $\triangle ADC$  is equilateral, then  $a^2 : b^2 : c^2$  is equal to  
 (a) 1 : 4 : 3 (b) 4 : 1 : 3  
 (c) 4 : 3 : 1 (d) 3 : 4 : 1
5. If in triangle  $ABC$ ,  $\frac{a^2 - b^2}{a^2 + b^2} = \frac{\sin(A-B)}{\sin(A+B)}$ , then the triangle is  
 (a) Right angled  
 (b) Isosceles  
 (c) Right angled or isosceles  
 (d) Right angled isosceles
6. We are given  $b$ ,  $c$  and  $\sin B$  such that  $B$  is acute and  $b < c \sin B$ . Then  
 (a) No triangle is possible  
 (b) One triangle is possible  
 (c) Two triangles are possible  
 (d) A right angled triangle is possible
7. The sides of triangles are  $3x + 4y$ ,  $4x + 3y$  and  $5x + 5y$  units, where  $x, y > 0$ . The triangle is  
 (a) Right angled (b) Equilateral  
 (c) Obtuse angled (d) None of these
8. In a  $\triangle ABC$   $a, c, A$  are given and  $b_1, b_2$  are two values of the third side  $b$  such that  $b_2 = 2b_1$ . Then  $\sin A =$   
 (a)  $\sqrt{\frac{9a^2 - c^2}{8a^2}}$  (b)  $\sqrt{\frac{9a^2 - c^2}{8c^2}}$   
 (c)  $\sqrt{\frac{9a^2 + c^2}{8a^2}}$  (d) None of these
9. If a triangle  $ABC$  has its sides in A.P., then  $\cos A + 2\cos B + \cos C$  is equal to  
 (a) 2 (b) 4  
 (c) 1 (d) None of these
10. If in a  $\triangle ABC$ ,  $\angle B = 90^\circ$ , then  $\sqrt{\frac{b-c}{b+c}}$  is equal to  
 (a)  $\tan \frac{A}{2}$  (b)  $2 \tan \frac{A}{2}$   
 (c)  $3 \tan \frac{A}{2}$  (d) None of these
11. In a  $\triangle ABC$ ,  $a = 5$ ,  $b = 7$  and  $\sin A = \frac{3}{4}$ , how many such triangles are possible?  
 (a) 1 (b) 0  
 (c) 2 (d) None of these
12. In a  $\triangle ABC$ ,  $a = 13$  cm,  $b = 12$  cm and  $c = 5$  cm. The distance of  $A$  from  $BC$  is  
 (a)  $\frac{144}{13}$  (b)  $\frac{65}{12}$   
 (c)  $\frac{60}{13}$  (d)  $\frac{25}{13}$
13. The sides of a triangle are three consecutive natural numbers and its largest angle is twice the smallest one. Then the sides of the triangle are  
 (a) 3, 4, 5 (b) 4, 5, 6  
 (c) 2, 5, 3 (d) 4, 3, 7

3.28 > Trigonometry

14. In a triangle  $ABC$ ,  $\sin A + \sin B + \sin C = 1 + \sqrt{2}$ ;  $\cos A + \cos B + \cos C = \sqrt{2}$ , if the triangle is  
 (a) equilateral  
 (b) isosceles  
 (c) right angled  
 (d) right angle isosceles
15. If in a  $\triangle ABC$ ,  $2 \cos A \sin C = \sin B$ , then the triangle is:  
 (a) equilateral (b) isosceles  
 (c) right angled (d) None of these
16. In a  $\triangle ABC$ ,  $\cos B \cdot \cos C + \sin B \cdot \sin C \sin^2 A = 1$ . Then the triangle is:  
 (a) right-angled isosceles  
 (b) isosceles whose equal angles are greater than  $\pi/4$   
 (c) equilateral  
 (d) none of these
17. In a  $\triangle ABC$ , the angles  $A$  and  $B$  are two different values of  $\theta$  satisfying  $\sqrt{3} \cos \theta + \sin \theta = k$ ,  $|k| < 2$ . The triangle:  
 (a) is an acute angled  
 (b) is a right angled  
 (c) is an obtuse angled  
 (d) has one angle  $= \frac{\pi}{3}$
18. In  $\triangle ABC$   $\cos^2 \frac{A}{2} + \cos^2 \frac{B}{2} + \cos^2 \frac{C}{2}$  is equal to:  

$$\frac{a}{2} + \frac{b}{2} + \frac{c}{2}$$
  
 (a)  $\frac{s^2}{2abc}$  (b)  $\frac{s^2}{abc}$   
 (c)  $\frac{s^2}{3abc}$  (d) none of these

**Answer Keys**

1. (d)    2. (c)    3. (a)    4. (b)    5. (c)    6. (a)    7. (c)    8. (b)    9. (a)    10. (a)  
 11. (b)    12. (c)    13. (b)    14. (d)    15. (b)    16. (a)    17. (c)    18. (b)

**CENTROID OF TRIANGLE AND LENGTH OF MEDIAN**

The point of intersection of medians of a triangle is called centroid of triangle. It is denoted by **G**. **Centroid** divides each of the three medians in the ratio 2: 1, where 2 towards the vertex and 1 towards side containing mid-point.

In triangle  $ABC$ , the mid-point of sides  $BC$ ,  $CA$  and  $AB$  are  $D$ ,  $E$  and  $F$  respectively. The lines  $AD$ ,  $BE$  and  $CF$  are called medians of the triangle  $ABC$ , the point of concurrency of three medians is called centroid. Generally, it is represented by  $G$ .

By geometry,

$$AG = \frac{2}{3} AD, BG = \frac{2}{3} BE \text{ and } CG = \frac{2}{3} CF.$$

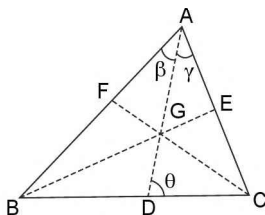

FIGURE 3.30

**Length of Medians:**

In  $\triangle ADC$ , by cosine formula,  
 $AD^2 = AC^2 + CD^2 - 2AC \cdot CD \cos C$   
 $\Rightarrow AD^2 = b^2 + a^2/4 - ab \cos C$   
 $\Rightarrow AD^2 = b^2 + a^2/4 - ab \left( \frac{b^2 + a^2 - c^2}{2ab} \right)$

$$\Rightarrow AD = \frac{1}{2} \sqrt{2b^2 + 2c^2 - a^2}$$

or  $AD = \frac{1}{2} \sqrt{b^2 + c^2 + 2bc \cos A}$

Similarly,  $BE = \frac{1}{2} \sqrt{2c^2 + 2a^2 - b^2}$

and  $CF = \frac{1}{2} \sqrt{2a^2 + 2b^2 - c^2}$

**The Angles that the Median Makes with Sides**

Let  $\angle BAD = \beta$ ,  $AD = x$  and  $\angle CAD = \gamma$ ,

we have  $\frac{\sin \gamma}{\sin C} = \frac{DC}{AD} = \frac{a}{2x}$  (Using sine formula in  $\triangle ADC$ )

$$\therefore \sin \gamma = \frac{a \sin C}{2x} = \frac{a \sin C}{\sqrt{2b^2 + 2c^2 - a^2}}$$

(By length of median AD)

$$\text{Similarly, } \sin \beta = \frac{a \sin B}{\sqrt{2b^2 + 2c^2 - a^2}}$$

$$\text{Again } \frac{\sin \theta}{\sin C} = \frac{AC}{AD} = \frac{b}{x}$$

$$\therefore \sin \theta = \frac{b \sin c}{x} = \frac{2b \sin c}{\sqrt{2b^2 + 2c^2 - a^2}}$$

### CIRCUMCIRCLE AND CIRCUMCENTRE OF TRIANGLE

The point of intersection of perpendicular bisectors of sides of a triangle is called **circumcentre** of triangle. It is denoted by **C**. The circle having its centre at circumcentre and circumscribing the triangle is called **circumcircle** of triangle. The radius of circumcircle is called **circumradius** of triangle and is denoted by **R**. In any triangle  $ABC$ ,

$$\frac{a}{\sin A} = \frac{b}{\sin B} = \frac{c}{\sin C} = 2R.$$

(i) **Radius of Circum Circle 'R' of any triangle**

Let  $ABC$  be the triangle, perpendicular bisectors of sides  $BC$  and  $CA$  meet in at  $O$ . By geometry  $O$  is the centre of the circum-circle. Join  $OB$  and  $OC$ . The point  $O$  may either lie within the triangle (figure-3.31), (acute angled triangle) outside the triangle (figure-3.32) (obtuse angled triangle) or upon one of the sides (figure-3.33) (right angled triangle).

In the figure  $\angle BOD = \frac{1}{2} \angle BOC = \angle BAC = A$

$$\text{also } \sin \angle BOD = \frac{BD}{BO} = \frac{a/2}{R} \therefore \sin A = \frac{a}{2R}$$

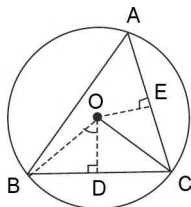

FIGURE 3.31

$$\therefore R = \frac{a}{2 \sin A} \text{ from the above figure, we have}$$

$$\therefore \angle BOD = \frac{1}{2} \angle BOC = \angle BLC = 180^\circ - A$$

$$\therefore \sin(\angle BOD) = \sin(180^\circ - A) = \sin A$$

$$\text{also } \sin \angle BOD = \frac{BD}{BO} = \frac{a/2}{R} \therefore R = \frac{a}{2 \sin A}$$

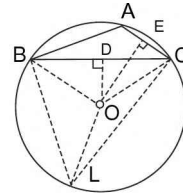

FIGURE 3.32

If  $A$  is a right angle as in figure-3.31, we have  $R = OA$

$$= OC = a/2 = \frac{a}{2 \sin A}$$

( $\because \sin A = \sin 90^\circ = 1$ )

Thus the relation found above is true for all triangles. Hence, in all three cases, we have

$$\frac{a}{\sin A} = \frac{b}{\sin B} = \frac{c}{\sin C} = 2R$$

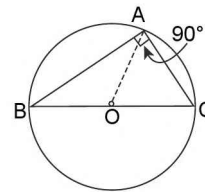

FIGURE 3.33

(ii) **The circumradius may be expressed in terms of sides of triangle.**

$$R = \frac{a}{2 \sin A} = \frac{a}{2 \cdot \frac{\Delta}{bc}} = \frac{abc}{4\Delta} \left( \because \Delta = \frac{1}{2} bc \sin A \right)$$

$$\Rightarrow R = \frac{abc}{4\Delta}$$

### INCIRCLE OF A TRIANGLE

The circle which can be inscribed within the triangle so as to touch each of the sides is called its **inscribed circle** or more briefly its **incircle**. The centre of this circle is called **incentre**. It is denoted by **I** and its radius always denoted by **r**. In-centre is the point of concurrency of **internal angles bisectors** of the triangle.

(i) **Radius r of the incircle of triangle ABC**

Let the bisector of internal angles  $B$  and  $C$  meet in  $I$ .

By geometry  $I$  is the centre of incircle. Join  $IA$  and draw  $ID, IE$  and  $IF$  perpendicular to three sides.

3.30 > Trigonometry

Then  $ID = IE = IF = r$

We have, area of  $\triangle ABC = \frac{1}{2}ID \cdot BC = \frac{1}{2}ra$

area of  $\triangle ICA = \frac{1}{2}IE \cdot CA = \frac{1}{2}rb$

area of  $\triangle IAB = \frac{1}{2}IF \cdot AB = \frac{1}{2}rc$

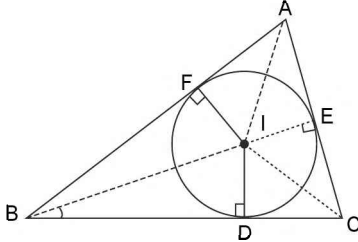

FIGURE 3.34

since  $\Delta = \text{Area } \triangle ABC + ar(\triangle ICA) + ar(\triangle IAB)$

$$\Rightarrow \Delta = \frac{1}{2}ar + \frac{1}{2}br + \frac{1}{2}cr = \frac{1}{2}(a + b + c)r$$

$$\therefore \Delta = sr \Rightarrow r = \Delta/s$$

- (ii) **To express the radius of incircle in terms of sides and tangent of the half angle.**

In the given figure (3.34),

$BD = BF$  (tangents drawn from  $B$  are equal in length)

$AE = AF$  (tangents drawn from  $A$  are equal in length)

$CE = CD$  (tangents drawn from  $C$  are equal in length)

Hence  $2BD + 2AF + 2CE = BD + CD + CE + AE + AF + BF$

$$\Rightarrow 2BD + 2AC = BC + CA + AB$$

$$2BD + 2b = a + b + c = 2s$$

$$\therefore BD = s - b = BF$$

Similarly,  $CE = s - c = CD$

and  $AF = s - a = AE$

Now in  $\triangle BID$ ,  $\frac{ID}{BD} = \tan \angle IBD = \tan B/2$

$$\therefore r = BD \tan B/2 = (s - b) \tan B/2$$

Similarly,  $r = CE \tan \angle ICE = (s - c) \tan C/2$

and  $r = IF = AF \tan \angle IAF = (s - a) \tan A/2$

$$\text{Hence } r = (s - a) \tan \frac{A}{2} = (s - b) \tan \frac{B}{2} = (s - c) \tan \frac{C}{2}$$

- (iii) **To express the radius of incircle in terms of one side and the functions of the half angles:**

From figure-3.34,  $BI$  and  $CI$  are angle bisectors so that  $\angle IBD = \angle B/2$  and  $\angle ICD = \angle C/2$

We have  $a = BD + CD = ID \cot \angle IBD + ID \cot \angle ICD$

$$= r \cot B/2 + r \cot C/2 = r \left[ \frac{\cos B/2}{\sin B/2} + \frac{\cos C/2}{\sin C/2} \right]$$

$$\Rightarrow a = r \left[ \frac{\cos \frac{B}{2} \sin \frac{C}{2} + \cos \frac{C}{2} \sin \frac{B}{2}}{\sin \frac{B}{2} \sin \frac{C}{2}} \right]$$

$$\Rightarrow a \sin B/2 \sin C/2 = r \left[ \sin \frac{C}{2} \cos \frac{B}{2} + \cos \frac{C}{2} \sin \frac{B}{2} \right]$$

$$= r \sin (B/2 + C/2)$$

$$= r \sin (90^\circ - A/2) = r \cos A/2$$

$$\Rightarrow r = \frac{a \sin B/2 \sin C/2}{\cos A/2}$$

$$\text{Thus } r = \frac{a \sin B/2 \sin C/2}{\cos A/2} = \frac{b \sin A/2 \sin C/2}{\cos B/2}$$

$$r = \frac{c \sin A/2 \sin B/2}{\cos C/2}$$

(2nd and 3rd parts can proved similarly)

Cor: since  $a = 2R \sin A = 4R \sin A/2 \cos A/2$

$$\therefore r = 4R \sin A/2 \sin B/2 \sin C/2.$$

**ESCRIBED CIRCLES**

A circle touching any one side of triangle and other two sides on producing is called an escribed circle. The centre of escribed circle is called ex-centre. The circle which touches the sides  $BC$  and two sides  $AB$  and  $AC$  (produced) of triangle  $ABC$  is called escribed circle opposite to angle  $A$ . The centre of escribed circle is called ex-centre and it is denoted by  $I_1$  or  $I_A$  and radius by  $r_1$  or  $r_A$ .

Similarly,  $r_2$  or  $r_B$  denotes the radius of the escribed circle which touches the side  $CA$  and the two sides  $BC$  and  $BA$  produced and its centre by  $I_2$ . Also  $r_3$  denotes the radius of the circle touching  $AB$  and two sides  $CA$  and  $CB$  produced and its centre by  $I_3$ .

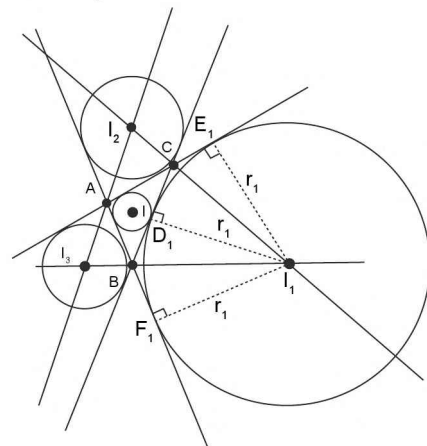

FIGURE 3.35

**(i) Radius of escribed circle of a triangle**

Let  $I_1$  be the centre of the circle touching the side  $BC$  and two sides  $AB$  and  $AC$  produced. Let  $D_1, E_1, F_1$  be the point of contact, then  $I_1D_1, I_1E_1$  and  $I_1F_1$  are perpendiculars to the sides  $BC, AC$  and  $AB$  respectively. Let  $r_1$  be the radius of the circle, then

$$\begin{aligned} \Delta &= \text{area of } \triangle ABC \\ &= \text{area of } \triangle BI_1A + \text{area of } \triangle CI_1A - \text{area of } \triangle BI_1C \\ &= \frac{1}{2}cr_1 + \frac{1}{2}br_1 - \frac{1}{2}ar_1 = \frac{1}{2}(b+c-a)r_1 \\ &= \frac{1}{2}(a+b+c-2a)r_1 = (s-a)r_1 \Rightarrow r_1 = \frac{\Delta}{s-a} \end{aligned}$$

Similarly, if  $r_2, r_3$  be the radii of the escribed circles opposite to the angles  $B$  and  $C$  respectively, then

$$r_2 = \frac{\Delta}{s-b}, r_3 = \frac{\Delta}{s-c}$$

**(ii) Radii of the escribed circles in terms of sides and the tangents of half angle**

In the figure - 3.35,  $AE_1$  and  $AF_1$  are tangents

$\therefore AE_1 = AF_1$  (tangents drawn from an external point are equal in lengths)

Similarly,  $BF_1 = BD_1$  and  $CE_1 = CD_1$

$$\begin{aligned} \therefore AB + BC + AC &= AB + BD_1 + D_1C + AC \\ &= (AB + BF_1) + (CE_1 + AC) \\ &= AF_1 + AE_1 = 2AF_1 \quad (\because AE_1 = AF_1) \\ &= 2AE_1 \end{aligned}$$

$$\Rightarrow AF_1 = s = AE_1 \quad \{ \because AB + BC + AC = 2s \}$$

$$\text{In } \triangle AF_1I_1, \frac{I_1F_1}{AF_1} = \tan \angle I_1AF_1$$

$$\therefore r_1 = s \tan A/2$$

Similarly,  $r_2 = s \tan B/2, r_3 = s \tan C/2$

**(iii) Radii of the escribed circles in terms of one side and function of half angles:**

In  $\triangle I_1BD_1$

$$\angle I_1BD_1 = \frac{\pi - B}{2}$$

$$\Rightarrow \frac{BD_1}{I_1D_1} = \cot \left( \frac{\pi - B}{2} \right)$$

$$\Rightarrow BD_1 = r_1 \tan B/2 \quad \dots(i)$$

$$\text{||}^y CD_1 = r_1 \tan C/2 \quad \dots(ii)$$

Adding (i) and (ii), we have

$$BD_1 + CD_1 = r_1 \left[ \tan \frac{B}{2} + \tan \frac{C}{2} \right]$$

$$\Rightarrow BC = r_1 \left[ \frac{\sin \frac{B}{2} \cos \frac{C}{2} + \sin \frac{C}{2} \cos \frac{B}{2}}{\cos \frac{B}{2} \cos \frac{C}{2}} \right]$$

$$\Rightarrow a = r_1 \left( \frac{\sin(B/2) \cos(C/2) + \sin(C/2) \cos(B/2)}{\cos(B/2) \cos(C/2)} \right)$$

$$\Rightarrow r_1 \sin \left( \frac{B+C}{2} \right) = a \cos(B/2) \cos(C/2)$$

$$\Rightarrow r_1 = \frac{a \cos(B/2) \cos(C/2)}{\cos A/2}$$

$$\text{Similarly, } r_2 = \frac{b \cos(C/2) \cos(A/2)}{\cos(B/2)}$$

$$\text{and } r_3 = \frac{c \cos(A/2) \cos(B/2)}{\cos(C/2)}$$

**Corollary:**

$$\text{since } a = 2R \sin A = 4R \sin(A/2) \cos(A/2)$$

$$\Rightarrow r_1 = 4R \sin(A/2) \cos(B/2) \cos(C/2)$$

$$r_2 = 4R \cos(A/2) \sin(B/2) \cos(C/2)$$

$$\text{and } r_3 = 4R \cos(A/2) \cos(B/2) \sin(C/2)$$

**ILLUSTRATION 30:** In a triangle  $ABC$ , prove that the area of the in-circle is to the area of the triangle itself

$$\text{is } \pi \cdot \cot \frac{A}{2} \cot \frac{B}{2} \cot \frac{C}{2}.$$

$$\text{SOLUTION: } \frac{\text{area of circle}}{\text{area of triangle}} = \frac{\pi r^2}{\Delta} = \frac{\pi}{\Delta} \cdot \frac{\Delta^2}{s^2} = \pi \cdot \frac{\Delta}{s^2} \quad \dots(i) \quad (\because r = \Delta/s)$$

$$\begin{aligned} \text{Now } \cot \frac{A}{2} \cdot \cot \frac{B}{2} \cot \frac{C}{2} &= \left[ \frac{s(s-a)}{(s-b)(s-c)} \cdot \frac{s(s-b)}{(s-c)(s-a)} \cdot \frac{s(s-c)}{(s-a)(s-b)} \right]^{1/2} \\ &= \left[ \frac{s^3}{(s-a)(s-b)(s-c)} \right]^{1/2} = \left[ \frac{s^4}{s(s-a)(s-b)(s-c)} \right]^{1/2} = s^2/\Delta \end{aligned}$$



$$\text{Now } \frac{\pi}{\cot \frac{A}{2} \cot \frac{B}{2} \cot \frac{C}{2}} = \frac{\pi}{s^2/\Delta} = \frac{\pi\Delta}{s^2} \quad \dots(\text{ii})$$

Hence from (1) and (2), we proved the required relation.

**ILLUSTRATION 31:** In any triangle, prove that  $\cos A + \cos B + \cos C = 1 + \frac{r}{R}$

**SOLUTION:** L.H.S. =  $\cos A + \cos B + \cos C$

$$\begin{aligned} &= 2 \cos \frac{A+B}{2} \cos \frac{A-B}{2} + 1 - 2 \sin^2 \frac{C}{2} \\ &= 1 + 2 \sin \frac{C}{2} \left[ \cos \frac{A-B}{2} - \cos \frac{(A+B)}{2} \right] \left\{ \because \frac{\pi}{2} = \frac{A+B}{2} - \frac{C}{2} \right\} \\ &= 1 + 4 \sin \frac{C}{2} \sin \frac{A}{2} \sin \frac{B}{2} \left\{ \because r = 4R \sin \frac{A}{2} \cdot \sin \frac{B}{2} \cdot \sin \frac{C}{2} \right\} \\ &= 1 + \frac{r}{R} = \text{R.H.S} \end{aligned}$$

**ILLUSTRATION 32:**  $r_1(s-a) = r_2(s-b) = r_3(s-c) = rs = \Delta$ .

**SOLUTION:**  $r_1(s-a) = \frac{\Delta}{s-a}(s-a) = \Delta$ .

$$r_2(s-b) = \frac{\Delta}{s-b}(s-b) = \Delta$$

$$r_3(s-c) = \frac{\Delta}{s-c}(s-c) = \Delta$$

Also  $rs = \frac{\Delta}{s} \cdot s = \Delta$ . **hence proved.**

**ILLUSTRATION 33:** In a triangle  $a : b : c = 4 : 5 : 6$ . Find the ratio of the radius of the circumcircle to that of the incircle.

**SOLUTION:** Let  $a = 4\lambda$ ,  $b = 5\lambda$  and  $c = 6\lambda$

$$\begin{aligned} \text{Now } \frac{R}{r} &= \frac{abc}{4\Delta r} = \frac{sabc}{4\Delta^2} \left[ \because r = \frac{\Delta}{s} \right] \\ &= \frac{(4\lambda \cdot 5\lambda \cdot 6\lambda) \left( \frac{15}{2} \lambda \right)}{4 \left( \frac{15}{2} \lambda \right) \left( \frac{7}{2} \lambda \right) \left( \frac{5}{2} \lambda \right) \left( \frac{3}{2} \lambda \right)} = \frac{900\lambda^4}{4 \left( \frac{15}{2} \lambda \right) \left( \frac{7}{2} \lambda \right) \left( \frac{5}{2} \lambda \right) \left( \frac{3}{2} \lambda \right)} = \frac{16}{7} \text{ Ans.} \end{aligned}$$

**ILLUSTRATION 34:** In any  $\triangle ABC$ , prove that  $\frac{1}{ab} + \frac{1}{bc} + \frac{1}{ca} = \frac{1}{2Rr}$

**SOLUTION:** L.H.S. =  $\frac{1}{ab} + \frac{1}{bc} + \frac{1}{ca} = \frac{c+a+b}{abc} = \frac{2s}{abc} = \frac{2rs}{rabc} = \frac{2\Delta}{rabc} = \frac{2}{r} \cdot \frac{1}{4R} = \frac{1}{2Rr}$

$\left( \because \Delta = \frac{abc}{4R} \right)$  **Hence proved.**

**ILLUSTRATION 35:** In any  $\Delta ABC$ , prove that  $4\left(\frac{s}{a}-1\right)\left(\frac{s}{b}-1\right)\left(\frac{s}{c}-1\right) = r/R$

**SOLUTION:**

$$4\left(\frac{s}{a}-1\right)\left(\frac{s}{b}-1\right)\left(\frac{s}{c}-1\right) = \frac{4}{abc}(s-a)(s-b)(s-c)$$

$$= \frac{4s(s-a)(s-b)(s-c)}{sabc} = \frac{\Delta(4\Delta)}{sabc} = \left(\frac{\Delta}{s}\right) \cdot \left(\frac{4\Delta}{abc}\right) = (r) \left(\frac{1}{R}\right) = \frac{r}{R}$$

$\left[ \because r = \frac{\Delta}{s} \text{ and } R = \frac{abc}{4\Delta} \right]$  Hence proved.

### TEXTUAL EXERCISE-4 (SUBJECTIVE)

- In a  $\Delta ABC$ , if  $a = 13$ ,  $b = 4$ ,  $\cos C = -5/13$ , find the value of  $R$ ,  $r$ ,  $r_1$ ,  $r_2$ ,  $r_3$ .
- If in a triangle  $ABC$ ;  $R$ ,  $r$ ,  $r_1$ ,  $r_2$ ,  $r_3$  are circumradius, inradius and exradii respectively and  $\Delta$ ,  $s$ ,  $a$ ,  $b$ ,  $c$  have their usual meanings, then prove the following results:
  - $r \cdot r_1 \cdot r_2 \cdot r_3 = \Delta^2$
  - $r_1 r_2 + r_2 r_3 + r_3 r_1 = s^2$
  - $(r_1 - r)(r_2 - r)(r_3 - r) = 4Rr^2$
  - $\Delta = 2R^2 \sin A \cdot \sin B \cdot \sin C$
  - $\frac{1}{bc} + \frac{1}{ca} + \frac{1}{ab} = \frac{1}{2Rr}$
  - $\frac{r_1}{r_2 r_3} = \tan^2 A/2$ .
  - $r^3 \cdot \cot^2 A/2 \cot^2 B/2 \cot^2 C/2 = r_1 r_2 r_3$
  - $r r_1 \cot A/2 = \Delta$
- If in a triangle  $ABC$ ;  $R$ ,  $r$ ,  $r_1$ ,  $r_2$ ,  $r_3$  are circumradius, inradius and exradii respectively and  $\Delta$ ,  $s$ ,  $a$ ,  $b$ ,  $c$  have their usual meanings, then prove the following results:
  - (i)  $1/r_1 + 1/r_2 + 1/r_3 = 1/r$
  - (ii)  $\frac{b-c}{r_1} + \frac{c-a}{r_2} + \frac{a-b}{r_3} = 0$
  - (iii)  $a(r r_1 + r_2 r_3) = b(r r_2 + r_3 r_1) = c(r r_3 + r_1 r_2) = abc$
  - (iv)  $4R \sin A \sin B \sin C = a \cos A + b \cos B + c \cos C$
  - (v)  $\Delta = 4R r \cos A/2 \cos B/2 \cos C/2$
- If  $(r_2 - r_1)(r_3 - r_1) = 2 r_2 r_3$ , prove that triangle is right angled.
- In right angled triangle, prove that  $r + 2R = s$ .
- Prove that area of triangle  $ABC$  i.e.,  $\Delta = \frac{1}{2} ab \sin C$ 

$$= \sqrt{s(s-a)(s-b)(s-c)} = \frac{abc}{4R} = \frac{a^1 \sin B \sin C}{2 \sin A} = \frac{abc}{3}$$

$$\cos A/2 \cos B/2 \cos C/2 = 4 R r \cos A/2 \cdot \cos B/2 \cdot \cos C/2$$
; where  $r$  and  $R$  are inradius and circumradius of  $\Delta ABC$  and  $S =$  perimeter of  $\Delta$ .
- In a triangle  $ABC$ 
  - If  $r_1 = r_2 + r_3 + r$ , prove that the triangle is right angled.
  - $r \cot B/2 \cdot \cot C/2 = r_1$ .
  - $\frac{1}{r^2} + \frac{1}{r_1^2} + \frac{1}{r_2^2} + \frac{1}{r_3^2} = \frac{a^2 + b^2 + c^2}{\Delta^2}$
  - $r_1 + r_2 + r_3 - r = 4R$
- The exradii  $r_1, r_2, r_3$  of  $\Delta ABC$  are in H.P. Show that its sides  $a, b, c$  are in A.P.
- If  $O$  is circumcentre of  $\Delta ABC$  and  $R_1, R_2, R_3$  are circumradii of triangles  $OBC, OCA$  and  $OAB$ , then prove that  $\frac{a}{R_1} + \frac{b}{R_2} + \frac{c}{R_3} = \frac{abc}{R^3}$ .
- In an acute angled triangle  $ABC$ , the circle on the altitude  $AD$  as diameter cuts  $AB$  at  $P$  and  $AC$  at  $Q$ . Show that  $PQ = 2R \sin A \sin B \sin C = \Delta/R$ .
- Find the ratios of  $IA:IB:IC$ , where  $I$  is the in centre of  $\Delta ABC$ .
- In a triangle  $ABC$ , prove that  $1 - \tan \frac{A}{2} \tan \frac{B}{2} = \frac{2c}{a+b+c}$

## Answer Keys

1.  $R = 65/8, r = 3/2, r_1 = 8, r_2 = 2, r_3 = 24$       9.  $\operatorname{cosec} A/2; \operatorname{cosec} B/2; \operatorname{cosec} C/2$

### TEXTUAL EXERCISE-4 (OBJECTIVE)

- In  $\triangle ABC$ ,  $2R^2 \sin A \sin B \sin C =$ 
  - $s^2$
  - $ab + bc + ca$
  - $\Delta$
  - None of these
- In  $\triangle ABC$ , if  $b = 6, c = 8$  and  $\angle A = 90^\circ$ , then  $R$  equals
  - 3
  - 4
  - 5
  - 7
- If the sides of a triangle are in ratio 3 : 7 : 8, then  $R : r$  is equal to
  - 2 : 7
  - 7 : 2
  - 3 : 7
  - 7 : 3
- If the sides of a triangle are 13, 14, 15, then the radius of its incircle is
  - $\frac{67}{8}$
  - $\frac{65}{4}$
  - 4
  - 24
- The inradius of the triangle whose sides are 3, 5, 6, is
  - $\sqrt{8/7}$
  - $\sqrt{8}$
  - $\sqrt{7}$
  - $\sqrt{7/8}$
- In an equilateral triangle the inradius is 1, then the circum-radius is
  - 1 cm
  - $\sqrt{3}$  cm
  - 2 cm
  - $2\sqrt{3}$  cm
- In an equilateral triangle the inradius and the circum-radius are connected by
  - $r = 4R$
  - $r = R/2$
  - $r = R/3$
  - None of these
- If the sides of the triangle are  $5K, 6K, 5K$  and radius of incircle is 6, then value of  $K$  is equal to
  - 4
  - 5
  - 6
  - 7
- In a triangle  $ABC$ , if  $b = 2, B = 30^\circ$ , then the area of circumcircle of triangle  $ABC$  in square units is
  - $\pi$
  - $2\pi$
  - $4\pi$
  - $6\pi$
- The circum-radius of the triangle whose sides are 13, 12 and 5 is
  - 15
  - $13/2$
  - $15/2$
  - 6
- If  $r_1, r_2$  and  $r_3$  are in A.P.,  $\cot(A/2), \cot(B/2)$  and  $\cot(C/2)$  are in
  - A.P.
  - H.P.
  - G.P.
  - None of these
- If  $r_1 = 2r_2 = 3r_3$ , then  $a + b + c$  is equal to
  - $3a$
  - $3b$
  - $3c$
  - None of these
- In any  $\triangle ABC$ ,  $2r(\sin A + \sin B + \sin C)$  is equal to
  - $\Delta$
  - $2\Delta$
  - $3\Delta$
  - $2\Delta/R$
- In any  $\triangle ABC$ ,  $r^2 \cot \frac{A}{2} \cot \frac{B}{2} \cot \frac{C}{2}$  is equal to
  - $\Delta$
  - $2\Delta$
  - $3\Delta$
  - None of these
- In a right angled triangle  $R$  is equal to
  - $\frac{s+r}{2}$
  - $\frac{s-r}{2}$
  - $s-r$
  - $\frac{s+r}{4}$
- In an equilateral triangle:
  - $r_1 = r_2 = r_3 = 2r$
  - $r_1 = r_2 = r_3 = r$
  - $r_1 = r_2 = r_3 = 3r$
  - None of these

## Answer Keys

1. (c)    2. (c)    3. (b)    4. (c)    5. (a)    6. (c)    7. (b)    8. (a)    9. (c)    10. (b)  
 11. (b)    12. (b)    13. (d)    14. (a)    15. (b)    16. (c)

## ORTHOCENTRE, PEDAL TRIANGLE AND ITS PROPERTIES

The point of intersection of the altitudes of a triangle is called **orthocentre** of triangle. It is denoted by  $O$  or  $H$ .

Let  $ABC$  be any triangle and let  $D, E, F$  be the feet of the perpendiculars from the angular points on the opposite sides of the triangle  $ABC$ , then  $DEF$  is known as **Pedal Triangle** of  $ABC$ .

The three perpendiculars  $AD, BE$  and  $CF$  always meet in a single point  $H$  which is called the orthocentre of triangle  $ABC$ .

**(i) Sides and Angles of the Pedal Triangle:**

In the fig angles  $HDC$  and  $HEC$  are right angles. Hence the points  $H, D, C$  and  $E$  are concyclic.

$$\therefore \angle HDE = \angle HCE = 90^\circ - A$$

$$\{\because \text{In } \triangle ACF, \angle AFC = 90^\circ \Rightarrow \angle ACF = 90^\circ - A\}$$

Similarly,  $H, D, B, F$  are concyclic therefore,  $\angle HDF = \angle HBF = 90^\circ - A$

Hence  $\therefore \angle FDE = 180^\circ - 2A$ ; so  $\angle DEF = 180^\circ - 2B$  and  $\angle EFD = 180^\circ - 2C$ . Thus the angles of Pedal Triangle  $FDE$  are

$$180^\circ - 2A, 180^\circ - 2B, 180^\circ - 2C.$$

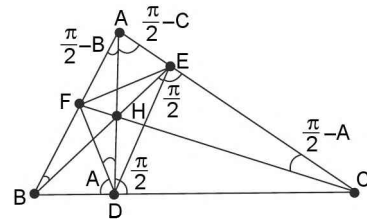

**FIGURE 3.36**

Angles of pedal  $\Delta$  are supplement of double of opposite angle of  $\Delta$ .

Again in  $\triangle BFD, \angle FDB = 90^\circ - \angle HDF$   
 $= 90^\circ - (90^\circ - A) = A$

$$\therefore \frac{FD}{\sin B} = \frac{BF}{\sin A} \Rightarrow FD = \frac{\sin B}{\sin A} \cdot BF = \frac{\sin B}{\sin A} \cdot BC \cdot \cos B$$

$$= \frac{a \sin B \cos B}{\sin A} = 2R \sin B \cos B = b \cos B$$

Similarly,  $EF = a \cos A$  and  $DE = c \cos C$ .

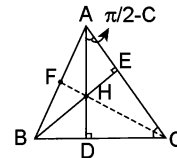

**FIGURE 3.37**

Thus the sides of the pedal triangle are  $a \cos A, b \cos B$  and  $c \cos C$ . In terms of  $R$ , the equivalent terms become  $R \sin 2A, R \sin 2B, R \sin 2C$ .

**REMARK**

If the angle  $ACB$  of the given triangle is obtuse, the expressions  $180^\circ - 2C$  and  $c \cos C$  are both negative and the values we have obtained, require some modification. In this case the angles are  $2A, 2B, 2C - 180^\circ$  and the sides are  $a \cos A, b \cos B, -c \cos C$

**(ii) Perimeter of Pedal Triangle:**

$$= 4R \cos A \cos B \sin C \text{ if } C \text{ is obtuse angle}$$

$$= 4R \cos A \sin B \cos C \text{ if } B \text{ is obtuse angle}$$

$$= 4R \sin A \cos B \cos C \text{ if } A \text{ is obtuse angle}$$

$$= R(\sin 2A + \sin 2B + \sin 2C) = 4R \sin A \sin B \sin C$$

If  $ABC$  is acute angled  $\Delta$

**(iii) Distance of the orthocentre from the angular points of the triangle:**

In  $\triangle ABC$  if  $AD, BE$  are altitude and  $H$  is orthocentre, then

$$AH = AE \sec(90^\circ - C) = AE \operatorname{cosec} C, \text{ Also } \frac{AE}{AB} = \cos A$$

$$\Rightarrow AH = AB \cdot \cos A \cdot \operatorname{cosec} C = c \cos A \cdot \frac{1}{\sin C} = 2R \cos A$$

$$= a \cot A$$

Similarly,  $BH = 2R \cos B = b \cot B \Rightarrow CH = 2R \cos C = c \cot C$

**(iv) Distances of the orthocentre from the sides of the triangle:**

From the fig, in  $\triangle BHD$

$$HD = BD \tan \angle HBD = AB \cos B \cdot \tan(90^\circ - C) = c \cos B \cdot \cot C$$

$$= \frac{c}{\sin C} \cdot \cos B \cdot \cos C = 2R \cos B \cos C$$

Similarly,  $HE = 2R \cos A \cos C$  and  $HF = 2R \cos A \cos B$

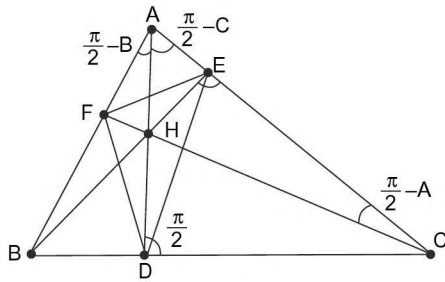

FIGURE 3.38

Cor.  $\frac{AH}{HD} = \frac{2R \cos A}{2R \cos B \cos C} = \frac{\sin A}{\cos B \cos C}$   
 $= \frac{\sin(B+C)}{\tan A}$   
 $= \frac{\cos B \cos C}{\tan A}$   
 $= \frac{\tan B + \tan C}{\tan A}$  i.e., orthocentre divides the altitude through  $A$  in ratio  $(\tan B + \tan C) : \tan A$

(v) **Area and Circum-radius of the Pedal Triangle:**  
 (For acute angled  $\Delta$ )

Area of triangle =  $\frac{1}{2}$  (product of two sides)  $\times$  (sin of included angle)

$= \frac{1}{2} (R \sin 2B) \cdot (R \sin 2C) \cdot \sin(180^\circ - 2A)$

$= \frac{1}{2} R^2 \sin 2A \sin 2B \sin 2C$

Circumradius =  $\frac{EF}{2 \sin FDE} = \frac{R \sin 2A}{2 \sin(180^\circ - 2A)} = \frac{R}{2}$

The in-radius of the Pedal Triangle  $DEF$

$DEF = \frac{\text{Ar}(\triangle DEF)}{\text{Semi Perimeter of } \triangle DEF}$

$= \frac{\frac{1}{2} R^2 \sin 2A \sin 2B \sin 2C}{2R \sin A \sin B \sin C}$

$= 2R \cos A \cos B \cos C$

(vi) **In-Centre of Pedal Triangle:**

We have proved that  $HD$ ,  $HE$  and  $HF$  bisect the angles  $FDE$ ,  $DEF$  and  $EFD$  respectively. So that  $H$  is the incentre of the triangle  $DEF$ . Thus the orthocentre of a triangle is the in-centre of the pedal triangle.

(vii) **The distance of the orthocentre from the circumcentre:** Let  $O \equiv$  Circumcentre,  $P \equiv$  Orthocentre

$\Rightarrow AO = R, AP = 2R \cos A$

$\Rightarrow OP^2 = OA^2 + AP^2 - 2OA \cdot AP \cdot \cos \theta$

$\Rightarrow \theta = A - 2(90^\circ - B) = A + 2B - \pi = B - C$

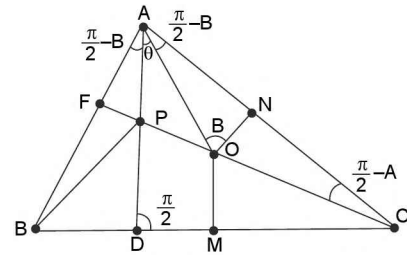

FIGURE 3.39

$\therefore OP^2 = R^2 + 4R^2 \cos^2 A - 4R^2 \cos A \cdot \cos(C - B)$   
 $= R^2 + 4R^2 \cos A [\cos A - \cos(C - B)]$   
 $= R^2 - 4R^2 \cos A [\cos(B + C) + \cos(C - B)]$   
 $= R^2 - 4R^2 \cos A \cdot 2 \cdot \cos B \cdot \cos C = R^2 - 8R^2 \cos A \cdot \cos B \cdot \cos C.$

$\therefore OP = R \sqrt{1 - 8 \cos A \cdot \cos B \cdot \cos C}.$

### CIRCUMCIRCLE OF PEDAL TRIANGLE (NINE POINT CIRCLE)

The circumcircle of pedal triangle for any  $\Delta ABC$  is called a nine point circle.

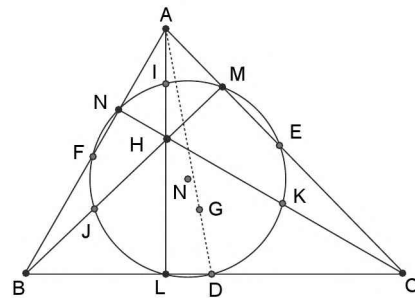

FIGURE 3.40

### Properties of nine point circle

1. It passes through nine points of triangle  $L, M, N$  (feet of altitudes)  $D, E, F$ ; (mid points of sides) and mid-points of  $HA, HB, HC$ ; where  $H$  is orthocentre of triangle  $ABC$ .
2. Its centre is called nine points centre ( $N$ ). It is circum-centre of pedal triangle.
3. Its radius is  $R_9 = \frac{1}{2}R$ .
4.  $O$  (orthocentre),  $N, G, C$  (circumcentre) are collinear.
  - $N$  divides  $OC$  in ratio 1:1
  - $G$  divides  $OC$  in ratio 2:1
5. If circumcentre of triangle be origin and centroid has coordinate  $(x, y)$ , then coordinate of orthocentre =  $(3x, 3y)$ ; coordinate of nine point centre =  $\left(\frac{3x}{2}, \frac{3y}{2}\right)$

**ILLUSTRATION 36:** If in a  $\Delta ABC$ ,  $a = 2$ ,  $b = 4$  and  $c = 3$ , then find the nine point radius of  $\Delta ABC$ .

**SOLUTION:** We know that  $R = \frac{abc}{4\Delta}$

$$= \frac{(2)(4)(3)}{4\sqrt{(s)(s-a)(s-b)(s-c)}} = \frac{6}{\sqrt{\left(\frac{9}{2}\right)\left(\frac{9}{2}-2\right)\left(\frac{9}{2}-4\right)\left(\frac{9}{2}-3\right)}}$$

$$= \frac{6}{\sqrt{\frac{9}{2} \times \frac{5}{2} \times \frac{1}{2} \times \frac{3}{2}}} = \frac{6 \times 4}{\sqrt{9 \times 5 \times 3}} = \frac{6 \times 4}{3\sqrt{15}} = \frac{8}{\sqrt{15}}$$

$\therefore$  Nine point radius  $= R_9 = 1/2(R) = \frac{4}{\sqrt{15}}$

**ILLUSTRATION 37:** If in a  $\Delta ABC$ ,  $a = 4$ ,  $c = 6$  and  $\Delta A = 60^\circ$ , then find nine point radius of  $\Delta ABC$ .

**SOLUTION:** By sine formula  $\frac{a}{\sin A} = \frac{b}{\sin B} = \frac{c}{\sin C} = 2R$

$$\Rightarrow \frac{4}{\sin 60^\circ} = \frac{b}{\sin B} = \frac{6}{\sin C} = 2R$$

$$\Rightarrow 2R = 4 \left( \frac{2}{\sqrt{3}} \right) = \frac{8}{\sqrt{3}} \Rightarrow R = \frac{4}{\sqrt{3}}$$

$\therefore$  Nine point radius  $= R/2 = \frac{2}{\sqrt{3}}$

**ILLUSTRATION 38:** The sides of pedal  $\Delta$  of a  $\Delta ABC$  are 2, 5 and 4 units. Find the nine point radius of  $\Delta ABC$ .

**SOLUTION:** Area of pedal  $\Delta$  of  $\Delta ABC$

$$\Delta' = \sqrt{\left(\frac{11}{2}\right)\left(\frac{11}{2}-2\right)\left(\frac{11}{2}-5\right)\left(\frac{11}{2}-4\right)} = \sqrt{\left(\frac{11}{2}\right)\left(\frac{7}{2}\right)\left(\frac{1}{2}\right)\left(\frac{3}{2}\right)} = \frac{\sqrt{77 \times 3}}{4} = \frac{\sqrt{231}}{4}$$

$$\text{Circum radius of pedal } \Delta = \frac{p \cdot q \cdot r}{4\Delta'} = \frac{(2)(5)(4)}{4 \left( \frac{\sqrt{231}}{4} \right)} = \frac{40}{\sqrt{231}}$$

## THE EX-CENTRAL TRIANGLE

Let  $ABC$  be a triangle and  $I$  be the centre of incircle. Let  $I_A, I_B, I_C$  be the centres of the escribed circles which are opposite to  $A, B$  and  $C$  respectively then  $I_A, I_B, I_C$  is called

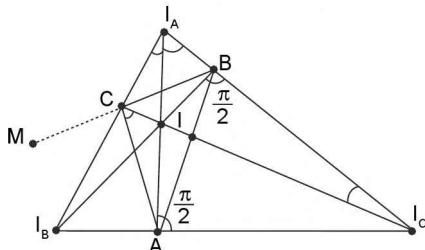

**FIGURE 3.41**

the ex-central triangle of  $\Delta ABC$ . By geometry  $IC$  bisects the angle  $ACB$  and  $I_B C$  bisects the angle  $ACM$ .

$$\angle I C I_B = \angle A C I + \angle A C I_B = \frac{1}{2}$$

$$\angle A C B + \frac{1}{2} \angle A C M = \frac{1}{2} \angle (180^\circ) = 90^\circ$$

Similarly,  $\angle I C I_A = 90^\circ$

Hence  $I_A I_B$  is a straight line perpendicular to  $IC$ . Similarly,  $AI$  is perpendicular to the straight line  $I_B I_C$  and  $BI$  is perpendicular to the straight line  $I_A I_C$ .

Also since  $IA$  and  $I_A A$  both bisect the angle  $BAC$ , hence  $A, I$  and  $I_A$  are collinear, similarly,  $B I I_B$  and  $C I I_C$  are straight lines.

Hence  $I_A, I_B, I_C$  is a triangle, thus the triangle  $ABC$  is the pedal triangle of its ex-central triangle  $I_A, I_B, I_C$ . The angles

**3.38** ➤ Trigonometry

$IBI_A$  and  $ICI_A$  are right angles, hence the points  $B, I, C, I_A$  are concyclic. Similarly,  $C, I, A, I_B$  and the points  $A, I, B, I_C$  are concyclic.

The lines  $AI_{A'}, BI_{B'}, CI_{C'}$  meet at the incentre  $I$ , which is therefore, the orthocentre of the ex-central triangle  $I_{A'} I_{B'} I_{C'}$ .

**REMARKS**

Each of the four points  $I, I_{A'}, I_{B'}, I_{C'}$  is the orthocentre of the triangle formed by joining the other three points.

■ **THE CENTROID LIES ON THE LINE JOINING THE CIRCUMCENTRE TO THE ORTHOCENTRE**

Let  $O$  and  $H$  represent the circum-centre and orthocentre respectively.  $OM$  is perpendicular to  $BC$ . Let  $AM$  meet  $HO$  at  $G$ . The two triangles  $AHG$  and  $GMO$  are equiangular.

$$AH = 2R \cos A \text{ and in } \triangle OMC, OM = R \cos A$$

$$\Rightarrow \frac{AH}{OM} = \frac{2R \cos A}{R \cos A} = 2$$

$$\text{Hence by similar triangles } \frac{AG}{GM} = \frac{HG}{GO} = \frac{AH}{OM} = 2$$

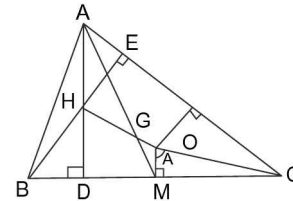

**FIGURE 3.42**

⇒  $G$  divides  $AM$  in the ratio  $2 : 1$ . Clearly,  $G$  is the centroid of  $\triangle ABC$  and  $G$  divides  $HO$  in the ratio  $2 : 1$ , thus centroid lies on the line joining the orthocentre to the circum-centre and divides it in the ratio  $2 : 1$ .

**REMARK**

The circumcentre, the centroid, the centre of the nine point circle and the orthocentre all lie on a straight line.

**ILLUSTRATION 39:** Prove that the distance between the incentre and circumcentre is given by

$$\sqrt{R^2 - 2Rr} = R \sqrt{1 - 8 \sin \frac{A}{2} \sin \frac{B}{2} \sin \frac{C}{2}}$$

**SOLUTION:** Let  $O$  be the circumcentre and  $I$  be the incentre of  $\triangle ABC$ .

$$\begin{aligned} \angle IAO &= \angle IAD - \angle OAD = \frac{A}{2} - (90^\circ - C) = \frac{A}{2} + C - 90^\circ = \frac{A}{2} + C - \left(\frac{A+B+C}{2}\right) \\ &= \left(\frac{C-B}{2}\right) \end{aligned} \quad \dots \text{(i)}$$

In  $\triangle OAI$ , by cosine formula

$$\begin{aligned} OP^2 &= (OA)^2 + (AI)^2 - 2(OA)(AI) \cos \angle IAO \\ &= R^2 + (AI)^2 - 2R(AI) \cos \left(\frac{C-B}{2}\right) \end{aligned} \quad \dots \text{(ii)}$$

Also in  $\triangle AIE$ ,  $\sin \frac{A}{2} = \frac{IE}{AI}$

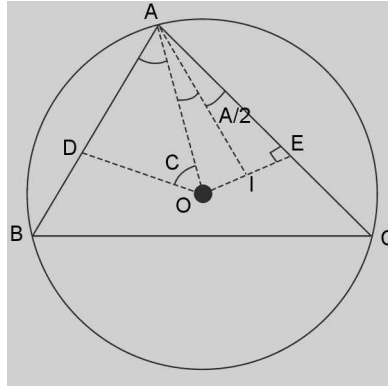
**FIGURE 3.43**

$$\Rightarrow AI = \frac{IE}{\sin \frac{A}{2}} = \frac{r}{\sin \frac{A}{2}} = \frac{4R \sin \frac{A}{2} \sin \frac{B}{2} \sin \frac{C}{2}}{\sin \frac{A}{2}}$$

$$\Rightarrow AI = 4R \sin \frac{B}{2} \sin \frac{C}{2} \quad \dots \text{(iii)}$$

$\therefore$  from (ii) and (iii) we have

$$OI^2 = R^2 + 16R^2 \sin^2 \frac{B}{2} \sin^2 \frac{C}{2} - 8R^2 \sin \frac{B}{2} \sin \frac{C}{2} \cos \left( \frac{C-B}{2} \right).$$

$$\begin{aligned} \Rightarrow \frac{(OI)^2}{R^2} &= 1 + 16 \sin^2 \frac{B}{2} \sin^2 \frac{C}{2} - 8 \sin \frac{B}{2} \sin \frac{C}{2} \left( \cos \frac{C}{2} \cos \frac{B}{2} + \sin \frac{C}{2} \sin \frac{B}{2} \right) \\ &= 1 - 8 \sin \frac{B}{2} \sin \frac{C}{2} \left[ \cos \frac{C}{2} \cos \frac{B}{2} + \sin \frac{C}{2} \sin \frac{B}{2} - 2 \sin \frac{B}{2} \sin \frac{C}{2} \right] \\ &= 1 - 8 \sin \frac{B}{2} \sin \frac{C}{2} \left[ \cos \frac{C}{2} \cos \frac{B}{2} - \sin \frac{B}{2} \sin \frac{C}{2} \right] = 1 - 8 \sin \frac{B}{2} \sin \frac{C}{2} \cos \left[ \frac{B}{2} + \frac{C}{2} \right] \\ &= 1 - 8 \sin \frac{B}{2} \sin \frac{C}{2} \cos \left[ 90^\circ - \frac{A}{2} \right] = 1 - 8 \sin \frac{A}{2} \sin \frac{B}{2} \sin \frac{C}{2} \end{aligned}$$

$$\begin{aligned} \therefore OI &= R \sqrt{1 - 8 \sin \frac{B}{2} \sin \frac{C}{2} \sin \frac{A}{2}} \Rightarrow OI = \sqrt{R^2 - 2R \left( 4R \sin \frac{A}{2} \sin \frac{B}{2} \sin \frac{C}{2} \right)} \\ &= \sqrt{R^2 - 2Rr} = R \sqrt{1 - \frac{2r}{R}}. \end{aligned}$$

$\therefore$  Distance between incentre and circumcentre of  $\triangle ABC$  is given by,

$$OI = R \sqrt{1 - 8 \sin \frac{A}{2} \sin \frac{B}{2} \sin \frac{C}{2}} = \sqrt{R^2 - 2Rr} \Rightarrow R \sqrt{1 - \frac{2r}{R}}$$

**ILLUSTRATION 40:** Find the distances of excentres from the circumcentre.

**SOLUTION:** Let  $O$  be the circumcentre and  $I$  be the incentre of  $\triangle ABC$ . Produce  $AI$  to meet circle at a point  $D$ . Let  $I_1$  be the excentre of  $\triangle ABC$  opposite to vertex  $A$ . Join  $B$  and  $C$  to  $D$ .

Now  $BD$  and  $CD$  subtend equal angles  $A/2$  at  $A$

$$\Rightarrow BD = CD$$



Join  $B$  and  $C$  to  $I_1$

Now  $\angle IBI_1 = \angle ICI_1 = 90^\circ$

⇒ If a circle is drawn taking  $II_1$  as diameter then it would pass through the points  $I, B, I_1$  and  $C$

$$\therefore BD = DC = DI_1 = DI = \frac{1}{2} (II_1) = \frac{1}{2} (4R \sin \frac{A}{2}) \left[ \because II_1 = 4R \sin \frac{A}{2} \right]$$

$$\Rightarrow BD = DC = DI = 2R \sin \frac{A}{2} \tag{1}$$

$$\text{Also } OI_1^2 - R^2 = (I_1T)^2 = I_1D \cdot I_1A \Rightarrow OI_1^2 = \left( 2R \sin \frac{A}{2} \right) \left( r_1 \operatorname{cosec} \frac{A}{2} \right)$$

$$\therefore OI_1^2 = R^2 + 2Rr_1$$

$$= R^2 + 2R \left( 4R \sin \frac{A}{2} \cos \frac{B}{2} \cos \frac{C}{2} \right) = R^2 + 8R^2 \sin \frac{A}{2} \cos \frac{B}{2} \cos \frac{C}{2}$$

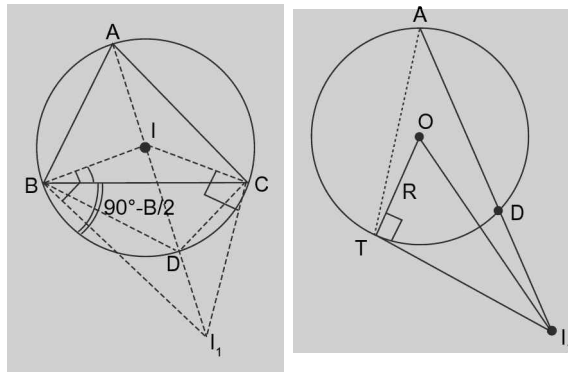

FIGURE 3.44

$$\therefore OI_1 = R \sqrt{1 + 8 \sin \frac{A}{2} \cos \frac{B}{2} \cos \frac{C}{2}}$$

$$\therefore OI_1 = \sqrt{R^2 + 2Rr_1} = R \sqrt{1 + \frac{2r_1}{R}} = R \sqrt{1 + 8 \sin \frac{A}{2} \cos \frac{B}{2} \cos \frac{C}{2}}$$

$$OI_2 = \sqrt{R^2 + 2Rr_2} = R \sqrt{1 + \frac{2r_2}{R}} = R \sqrt{1 + 8 \cos \frac{A}{2} \sin \frac{B}{2} \cos \frac{C}{2}}$$

$$OI_3 = \sqrt{R^2 + 2Rr_3} = R \sqrt{1 + \frac{2r_3}{R}} = R \sqrt{1 + 8 \cos \frac{A}{2} \cos \frac{B}{2} \sin \frac{C}{2}}$$

**ILLUSTRATION 41:** If  $x, y, z$  are the distances of the vertices of the triangle  $ABC$  respectively from the orthocentre

the  $n$ , prove that  $\frac{a}{x} + \frac{b}{y} + \frac{c}{z} = \frac{abc}{xyz}$ .

**SOLUTION:** Given:  $OA = x$ ;  $OB = y$ ;  $OC = z$

In quadrilateral  $ALOM$

$$\angle LOM = \pi - A$$

$$\Rightarrow \angle BOC = \pi - A \text{ (vertically opposite angles)}$$

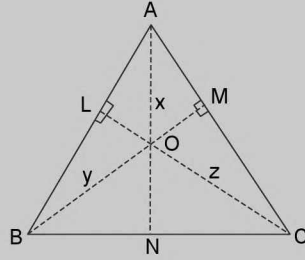

FIGURE 3.45

$$\begin{aligned} \Rightarrow \text{Ar } \triangle OBC &= \frac{1}{2} OB \cdot OC \cdot \sin \angle BOC = \frac{1}{2} yz \sin A \\ \text{Similarly, ar } \triangle AOC &= \frac{1}{2} xz \sin B \text{ and area of } \triangle AOB = \frac{1}{2} xy \sin C \\ \text{Now, ar } \triangle ABC &= \text{ar } \triangle AOB + \text{ar } \triangle BOC + \text{ar } \triangle AOC \\ \Rightarrow \Delta &= \frac{1}{2} (xy \sin C + yz \sin A + xz \sin B) \\ &= \frac{xyz}{2} \left( \frac{\sin A}{x} + \frac{\sin B}{y} + \frac{\sin C}{z} \right) = \frac{xyz}{2} \frac{1}{2R} \left( \frac{a}{x} + \frac{b}{y} + \frac{c}{z} \right) \quad (\text{By sine formula}) \end{aligned}$$

$$\begin{aligned} \text{Also we known that } \Delta &= \frac{abc}{4R} \\ \therefore \frac{abc}{4R} &= \frac{xyz}{4R} \left( \frac{a}{x} + \frac{b}{y} + \frac{c}{z} \right) \Rightarrow \frac{a}{x} + \frac{b}{y} + \frac{c}{z} = \frac{abc}{xyz} \text{ hence proved.} \end{aligned}$$

**ILLUSTRATION 42:** If  $g, h, k$  denotes the sides of a pedal triangle then prove that  $\frac{g}{a^2} + \frac{h}{b^2} + \frac{k}{c^2} = \frac{a^2 + b^2 + c^2}{2abc}$ .

**SOLUTION:** We know that sides of pedal  $\Delta$  are given by  $a \cos A, b \cos B$  and  $c \cos C$ .

$$\begin{aligned} \text{Let } g &= a \cos A, h = b \cos B \text{ and } k = c \cos C \\ \therefore \frac{g}{a^2} + \frac{h}{b^2} + \frac{k}{c^2} &= \frac{a \cos A}{a^2} + \frac{b \cos B}{b^2} + \frac{c \cos C}{c^2} \\ &= \frac{\cos A}{a} + \frac{\cos B}{b} + \frac{\cos C}{c} \\ &= \left( \frac{b^2 + c^2 - a^2}{2abc} \right) + \left( \frac{a^2 + c^2 - b^2}{2abc} \right) + \left( \frac{a^2 + b^2 - c^2}{2abc} \right) \quad (\text{by cosine formula}) \\ &= \frac{a^2 + b^2 + c^2}{2abc}. \text{ Hence proved.} \end{aligned}$$

### ■ THE LENGTH OF ANGLE BISECTOR AND THE ANGLE THAT THE BISECTOR MAKES WITH THE SIDES

Let  $AD$  be the bisector of angle  $A$  and  $x$  and  $y$  be the portions of base  $BC$ . From geometry

$$\frac{BD}{DC} = \frac{AB}{AC} \text{ or } \frac{x}{c} = \frac{y}{b} = \frac{x+y}{b+c} = \frac{a}{b+c}$$

$$\therefore x = \frac{ac}{b+c} \text{ and } y = \frac{ab}{b+c} \quad \dots(i)$$

Further  $\triangle ABC = \triangle ABD + \triangle ADC$

$$\frac{1}{2} bc \sin A = \frac{1}{2} cz \sin A/2 + \frac{1}{2} bz \sin A/2$$

$$z = \left( \frac{bc}{b+c} \right) \cdot \frac{\sin A}{\sin A/2} = \left( \frac{2bc}{b+c} \right) \cos A/2 \quad \dots(ii)$$

3.42 > Trigonometry

$$= \frac{abc}{2R(b+c)} \operatorname{cosec} \frac{A}{2} = \frac{2\Delta}{(b+c)} \operatorname{cosec} \frac{A}{2}$$

Also  $\theta = \angle BAD + B = A/2 + B$

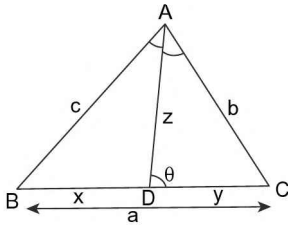

FIGURE 3.46

■ THE PERIMETER AND AREA OF A REGULAR POLYGON OF  $n$ -SIDES INSCRIBED IN A CIRCLE

Let  $DA$ ,  $AB$  and  $BC$  be three successive sides of the polygon of  $n$  sides. Let  $r$  be the radius of the circle  $OL$  is the bisector of  $\angle AOB$ , then  $OL$  is perpendicular to  $AB$  and

$$\angle AOB = \frac{1}{n}(2\pi) = \frac{2\pi}{n} \therefore \angle AOB = \frac{1}{2} \angle AOB = \frac{\pi}{n}$$

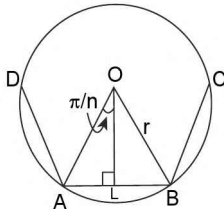

FIGURE 3.47

$$\therefore AL = OA \sin \angle AOB = r \sin \frac{\pi}{n}$$

$$\text{Perimeter of polygon} = nAB = 2nAL = 2nr \sin \frac{\pi}{n}$$

$$\text{Area of polygon} = n(\text{Area of triangle } AOB)$$

$$= \frac{nr^2}{2} \sin \frac{2\pi}{n}$$

■ THE PERIMETER AND AREA OF REGULAR POLYGON OF  $n$ -SIDES CIRCUMSCRIBED ABOUT A GIVEN CIRCLE

Let  $DA$ ,  $AB$  and  $BC$  be three successive sides of the polygon of  $n$  sides. Let  $r$  be the radius of given circle.  $OL$  is perpendicular to  $AB$

$$\text{In } \triangle AOL, AL = OL \tan \frac{\pi}{n}$$

$$\therefore \text{Perimeter of Polygon} = nAB = 2nAL$$

$$= 2nOL \tan \frac{\pi}{n} = 2nr \tan \frac{\pi}{n}$$

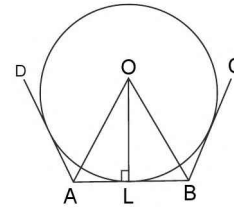

FIGURE 3.48

$$\text{Area of Polygon} = n(\text{Area of triangle } AOB)$$

$$= n \frac{(OL \cdot AB)}{2} = nr^2 \tan \frac{\pi}{n}$$

■ THE RADII OF THE INSCRIBED AND CIRCUMSCRIBING CIRCLES OF A REGULAR POLYGON

Let  $DA$ ,  $AB$  and  $BC$  be three successive sides of the polygon of  $n$  sides;  $OL$  is the bisector of  $\angle AOB$ ; therefore  $OL$  is perpendicular to  $AB$ .

By geometry  $O$  is the centre of both the incircle and the circum circle of the Polygon.

$$\text{Let } OA = OB = R \text{ (radius of circum circle) and } OL = r \text{ (radius of in-circle); } \angle AOB = \frac{4 \text{ right angle}}{n} = \frac{2\pi}{n} \text{ radians}$$

$$\therefore \angle BOL = \angle AOB = \frac{1}{2} \angle AOB = \frac{\pi}{n}$$

If  $a$  be the sides of polygon, we have

$$a = AB = 2AL = 2R \sin \frac{\pi}{n}$$

$$\therefore R = \frac{a}{2 \sin \pi/n} = \frac{a}{2} \operatorname{cosec} \frac{\pi}{n}$$

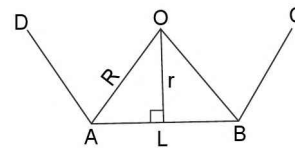

FIGURE 3.49

$$\text{Again } a = 2AL = 2 \cdot OL \tan \frac{\pi}{n} = 2r \tan \frac{\pi}{n}$$

$$\therefore r = \frac{a}{2 \tan \pi/n} = \frac{a}{2} \cot \frac{\pi}{n}$$

**ILLUSTRATION 43:** If  $A_0, A_1, A_2, A_3, A_4$  and  $A_5$  be the consecutive vertices of a regular hexagon inscribed in a unit circle. Then find the product of length of  $A_0A_1, A_0A_2$  and  $A_0A_4$ .

**SOLUTION:**  $A_0A_1 = 1$

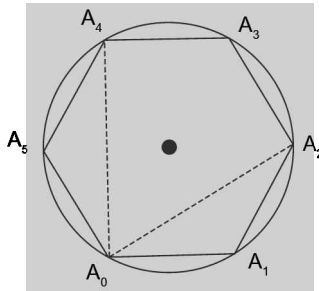

FIGURE 3.50

$$\Rightarrow \angle A_0A_1A_2 = \frac{n-2}{n} \times 180^\circ = \frac{6-2}{6} \times 180^\circ = 120^\circ$$

$$\therefore \text{By cosine formula } \cos 120^\circ = \frac{(A_0A_1)^2 + (A_1A_2)^2 - (A_0A_2)^2}{2(A_0A_1)(A_1A_2)}$$

$$\Rightarrow \frac{-1}{2} = \frac{1+1-(A_0A_2)^2}{2 \times 1 \times 1} \Rightarrow A_0A_2 = \sqrt{3}$$

Similarly,  $A_0A_4 = \sqrt{3}$

$$\therefore (A_0A_1)(A_0A_2)(A_0A_4) = 1 \times \sqrt{3} \times \sqrt{3} = 3 \text{ Ans.}$$

**ILLUSTRATION 44:** If the area of circle is  $A_1$  and area of regular pentagon inscribed in the circle is  $A_2$ , find the ratio of area of two.

**SOLUTION:** Let  $r$  be the radius of circle and ' $a$ ' be each side of regular pentagon inscribed in circle.

$$\therefore A_1 = \text{area of circle} = \pi r^2 \quad \dots (i)$$

$$\text{and } A_2 = \text{area of regular pentagon} = 5 \times \left( \frac{1}{4} a^2 \cot 36^\circ \right)$$

$$\left[ \begin{array}{l} \because \operatorname{cosec} 36^\circ = \frac{2r}{a} \\ \frac{r}{a} = \frac{1}{2 \sin 36^\circ} \end{array} \right]$$

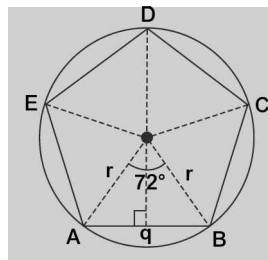

FIGURE 3.51

$$\begin{aligned} \therefore \frac{A_1}{A_2} &= \frac{4\pi r^2}{5a^2 \cot 36^\circ} = \frac{4\pi}{5} \left( \frac{r}{a} \right)^2 \times \tan 36^\circ = \frac{4\pi}{5} \left( \frac{1}{2 \sin 36^\circ} \right)^2 \tan 36^\circ \\ &= \frac{\pi}{5} \times \frac{1}{\sin 36^\circ \cos 36^\circ} = \frac{2\pi}{5 \sin 72^\circ} = \frac{2\pi}{5 \left[ \frac{\sqrt{10+2\sqrt{5}}}{4} \right]} = \frac{8\pi}{5\sqrt{10+2\sqrt{5}}} \end{aligned}$$

**ILLUSTRATION 45:** A regular pentagon and a regular decagon have the same perimeter, prove that their areas are as  $2 : \sqrt{5}$ .

**SOLUTION:** Let  $a$  and  $b$  be each side of regular pentagon and regular decagon respectively. A.T.Q.

$$5a = 10b \Rightarrow a = 2b \quad \dots (i)$$

$$\begin{aligned} \therefore \frac{A_1}{A_2} &= \frac{\text{area of regular pentagon}}{\text{area of regular decagon}} = \frac{\frac{5}{4}a^2 \cot 36^\circ}{\frac{10}{4}b^2 \cot 18^\circ} = \frac{2b^2}{b^2} \left( \frac{2 \cos^2 18^\circ - 1}{2 \cos^2 18^\circ} \right) \\ &= 2 \left[ 1 - \frac{1}{2} \cdot \frac{16}{10 + 2\sqrt{5}} \right] = 2 \left[ 1 - \frac{4}{5 + \sqrt{5}} \right] = 2 \left[ \frac{1 + \sqrt{5}}{5 + \sqrt{5}} \right] = \frac{2}{\sqrt{5}}. \text{ Hence proved.} \end{aligned}$$

**ILLUSTRATION 46:** A circle is inscribed in an equilateral triangle of side  $a$  find the area of any equilateral triangle inscribed in the circle.

**SOLUTION:**  $\therefore AD = \text{Altitude} = \text{Angle bisector (median)}$

$$\therefore OD = r = \frac{1}{3} \sqrt{\frac{3a^2}{4}} = \frac{a}{2\sqrt{3}} \text{ or } \frac{a}{2} \cot \frac{\pi}{3} = \frac{a}{2\sqrt{3}}$$

$$\therefore \text{Area of } \triangle GHI = 3 (\text{ar } \triangle OHI) = 3 \left( \frac{1}{2} r^2 \sin 120^\circ \right) = 3 \left( \frac{1}{2} \cdot \left( \frac{a^2}{12} \right) \frac{\sqrt{3}}{2} \right) = \frac{\sqrt{3}}{16} a^2 \text{ square units.}$$

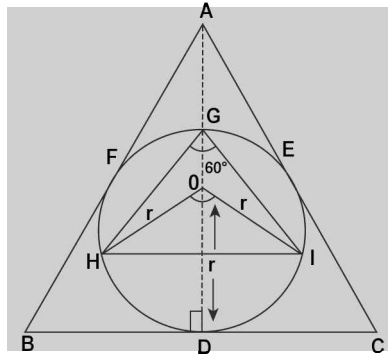

FIGURE 3.52

**ILLUSTRATION 47:** A circle is inscribed in an equilateral  $\Delta$  having each side =  $a$  units, An equilateral  $\Delta$  is again constructed with in the circle, then find the length of each side of new constructed equilateral triangle.

**SOLUTION:** From above example are a of new constructed equilateral triangle.

$$= \frac{\sqrt{3}}{16} a^2 = \frac{\sqrt{3}}{4} x^2 \quad (x = \text{each side new equilaterals})$$

$$\Rightarrow x^2 = \frac{a^2}{4} \Rightarrow x = a/2 \text{ unit.}$$

**ILLUSTRATION 48:** In a  $\Delta ABC$  bisector of  $LA$  meets  $BC$  at  $D$  and the circumcircle of  $\Delta ABC$  at  $G$ , then find the maximum value of  $AD.DG$ .

**SOLUTION:** By properties of circle  $AD.DG = BD.DC$

$$\text{Now, by } AM \geq GM \text{ we have, } \frac{BD + DC}{2} \geq \sqrt{BD.DC}$$

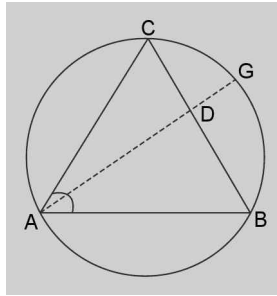
**FIGURE 3.53**

$$\Rightarrow \frac{a}{2} \geq \sqrt{BD \cdot DC} \Rightarrow BD \cdot DC \leq \frac{a^2}{4} \Rightarrow AD \cdot DG \leq \frac{a^2}{4}$$

$$\therefore \text{Maximum value of } AD \cdot DG = \frac{a^2}{4}$$

**ILLUSTRATION 49:** Find the largest side of  $\triangle ABC$  that can be inscribed in a circle so that  $\frac{a^3 + b^3 + c^3}{\sin^3 A + \sin^3 B + \sin^3 C} = 64$ .

**SOLUTION:** 
$$\frac{8R^3 (\sin^3 A + \sin^3 B + \sin^3 C)}{(\sin^3 A + \sin^3 B + \sin^3 C)} = 64 \Rightarrow R^3 = 8 \Rightarrow R = 2 \text{ units}$$

We know that the length of any side of  $\triangle$  that can be inscribed in a circle has maximum value equal to the diameter of circle = 4 units.

**ILLUSTRATION 50:** In a cubical hall  $G$  is the centre of cube and  $M$  is the mid point of one of the base edges, then find the angle subtended by  $GM$  with the base, given that each edge of cube is 10 cm.

**SOLUTION:** In rt  $\triangle AMLG$ ,  $MG = \sqrt{ML^2 + LG^2} = \sqrt{25 + 25} = \sqrt{50} = 5\sqrt{2}$  cm

$$\therefore \sin \theta = \frac{GL}{MG} = \frac{5}{5\sqrt{2}} = \frac{1}{\sqrt{2}} \Rightarrow \theta = 45^\circ$$

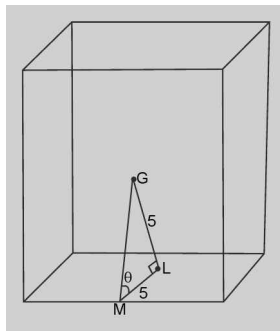
**FIGURE 3.54**

**ILLUSTRATION 51:** Each side of an equilateral triangle subtend an angle of  $60^\circ$  at a P at a height  $H$  metre above the centre of  $\triangle$ , then show that  $2a^2 = 3H^2$ , where  $a$  is each side of  $\triangle$ .

**SOLUTION:** Due to symmetry,  $AP = BP$

$\Rightarrow \triangle ABP$  is also an equilateral  $\triangle$

$$\therefore BP = a, OP = H$$

$$\text{In } \triangle OBL, \sec 30^\circ = \frac{OB}{a/2} \Rightarrow OB = \frac{a}{2} \sec 30^\circ$$

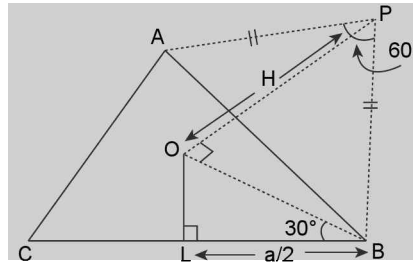

FIGURE 3.55

Now in rt  $\angle \Delta OBP$

$$OB^2 + OP^2 = BP^2 \Rightarrow \left(\frac{a}{2} \sec 30^\circ\right)^2 + H^2 = a^2 \Rightarrow \frac{a^2}{4} \left(\frac{4}{3}\right) + H^2 = a^2 \Rightarrow H^2 = a^2 - \frac{1}{3}a^2$$

$$\Rightarrow H^2 = \frac{2}{3}a^2 \Rightarrow 2a^2 = 3H^2 \text{ Hence Proved.}$$

**ILLUSTRATION 52:** In a cyclic quadrilateral, find the product of diagonals in terms of sides of quadrilateral.

**SOLUTION:** Let  $AC = p$  and  $BD = q$

$$\therefore \cos B = \frac{a^2 + b^2 - p^2}{2ab} \Rightarrow p^2 = a^2 + b^2 - 2ab \cos B \quad \dots (i)$$

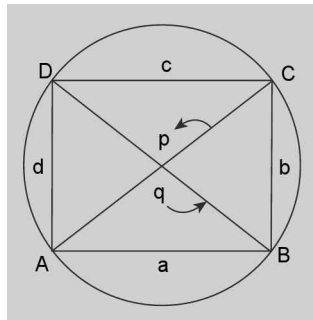

FIGURE 3.56

$$\text{Also } p^2 = c^2 + d^2 - 2cd \cos D = c^2 + d^2 + 2cd \cos (\pi - B) = c^2 + d^2 + 2cd \cos B \quad \dots (ii)$$

$$\therefore a^2 + b^2 - 2ab \cos B = c^2 + d^2 + 2cd \cos B$$

$$\Rightarrow \cos B = \frac{a^2 + b^2 - c^2 - d^2}{2(ab + cd)}$$

$$\therefore \text{From (i) } p^2 = a^2 + b^2 - \frac{ab(a^2 + b^2 - c^2 - d^2)}{(ab + cd)} = \frac{(a^2 + b^2)(ab + cd) - ab(a^2 + b^2 - c^2 - d^2)}{(ab + cd)}$$

$$= \frac{(a^2 + b^2)cd + ab(c^2 + d^2)}{(ab + cd)} = \frac{ac(ad + bc) + bd(bc + ad)}{(ab + cd)} = \frac{(ac + bd)(bc + ad)}{(ab + cd)}$$

$$\text{Similarly, } q^2 = \frac{(ac + bd)(ab + cd)}{(ad + bc)}$$

$$\therefore p^2 \cdot q^2 = (ac + bd)^2 \Rightarrow p \cdot q = (ac + bd).$$

$\therefore$  Product of diagonals of a cyclic quadrilateral is equal to sum of product of opposites sides

**ILLUSTRATION 53:** If a regular pentagon and regular decagon have the same perimeter, then find the ratio of their areas.

**SOLUTION:** Let  $5a = 10b = p$  (perimeter)

$$\Rightarrow a = \frac{p}{5}; b = \frac{p}{10}$$

$$\text{area of regular pentagon} = 5 \left[ \frac{1}{2} \times a \left( \frac{a}{2} \cot 36^\circ \right) \right]$$

$$A_1 = \frac{5}{4} a^2 \cot 36^\circ$$

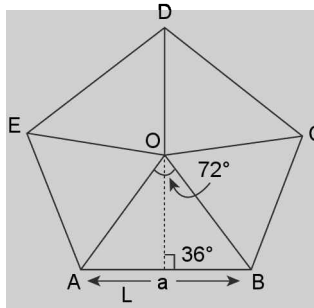

**FIGURE 3.57**

$$\left[ \because \cot 36^\circ = \frac{OL}{AL} \Rightarrow OL = AL \cot 36^\circ = \frac{a}{2} \cot 36^\circ \right]$$

$$\text{and Area of regular decagon} = 10 \left[ \frac{1}{2} \times b \times \frac{b}{2} \cot 18^\circ \right]$$

$$A_2 = \frac{10}{4} b^2 \cot 18^\circ$$

$$\therefore \frac{A_1}{A_2} = \frac{\frac{1}{4} a^2 \cot 36^\circ}{\frac{10}{4} b^2 \cot 18^\circ} = \frac{1}{2} (2)^2 \frac{\cot 36^\circ}{\cot 18^\circ} = 2 \frac{\cot 36^\circ}{\cot 18^\circ} = 2 \left[ \frac{1 - \tan^2 18^\circ}{2 \tan 18^\circ \cot 18^\circ} \right]$$

$$= 1 - \tan^2 18^\circ$$

.....(i)

$$= 1 - \left( \frac{\sqrt{25 - 10\sqrt{5}}}{5} \right)^2 = 1 - \left( \frac{25 - 10\sqrt{5}}{25} \right) = 1 - \left( 1 - \frac{2}{5}\sqrt{5} \right) = 1 - 1 + \frac{2}{\sqrt{5}} = \frac{2}{\sqrt{5}}$$

**ILLUSTRATION 54:** A quadrilateral  $ABCD$  in which  $AB = a$ ,  $BC = b$ ,  $CD = c$  and  $DA = d$  a circle is inscribed in it,

and another circle is circumscribed about it, then show that  $\cos A = \frac{ad - bc}{ad + bc}$ .

**SOLUTION:**  $\cos A = \frac{a^2 + d^2 - p^2}{2ad}$ ,  $\cos(\pi - A) = \frac{c^2 + b^2 - p^2}{2cb}$

$$\therefore \cos A = \frac{p^2 - c^2 - b^2}{2cb} \Rightarrow p^2 = a^2 + d^2 - 2ad \cos A; p^2 = c^2 + b^2 + 2cb \cos A$$

$$\Rightarrow a^2 + d^2 - 2ad \cos A = c^2 + b^2 + 2cb \cos A \Rightarrow 2 \cos A (-cb - ad) = b^2 + c^2 - a^2 - d^2$$

$$\Rightarrow \cos A = \frac{-b^2 - c^2 + a^2 + d^2}{2(bc + ad)} = \frac{a^2 + d^2 - b^2 - c^2}{2(ad + bc)}$$

.....(i)



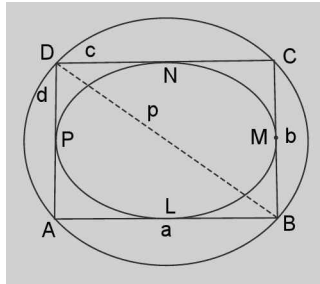

FIGURE 3.58

$$\begin{aligned}
 & \left. \begin{array}{l} AL = AP \\ BL = BM \\ DN = DP \\ CN = CM \end{array} \right\} \Rightarrow \begin{array}{l} a + c = d + b \\ a - d = b - c \end{array} \Rightarrow a^2 + d^2 - 2ad = b^2 + c^2 - 2bc \\
 \Rightarrow a^2 + d^2 - b^2 - c^2 &= 2(-bc + ad) \Rightarrow \cos A = \frac{(ad - bc)}{ad + bc}
 \end{aligned}$$

**ILLUSTRATION 55:** If  $r$  is the radius of incircle of a right angled  $\Delta$  having right angle  $\angle C$  and  $R$  is its circumradius, then prove that  $2(r + R) = a + b$ .

**SOLUTION:**  $CL = CM$ ;  $LB = BN$ ,  $AM = AN$

$$\Rightarrow AC + BC = AM + MC + CL + LB = AN + r + r + BN = AN + BN + 2r$$

$$\Rightarrow AC + BC = AB + 2r$$

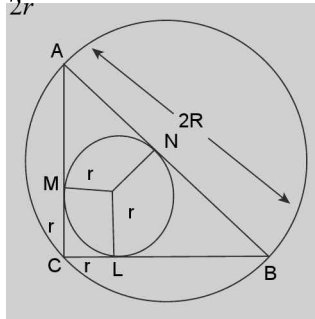

FIGURE 3.59

$$\Rightarrow b + a = c + 2r \Rightarrow b + a = 2R + 2r \Rightarrow 2(r + R) = a + b.$$

**ILLUSTRATION 56:** A circle is inscribed in an equilateral  $\Delta$  of side 4 unit. Find the area of square inscribed in this circle.

**SOLUTION:** Let  $ABC$  be a  $\Delta$  of each side 4 units and a circle of radius ( $r$ ) be inscribed in  $\Delta ABC$ , having its centre at  $O$ . Since the  $\Delta$  is equilateral, the incentre  $O$ , centroid and orthocentre coincide.

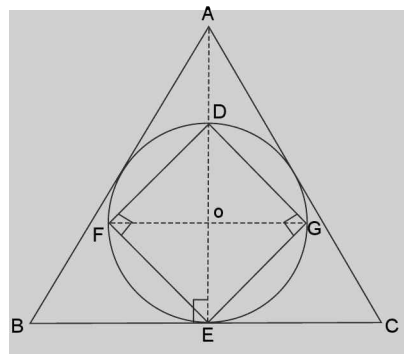

FIGURE 3.60

$$\therefore DE = 2r \text{ units and area of square} = \frac{1}{2}(d)^2 = \frac{1}{2}(2r)^2 = \frac{1}{2}(4r^2) = 2r^2$$

$$\text{Now, } r = OE = \frac{1}{3}AE = \frac{1}{3} \left[ \sqrt{(AB^2) - (BE)^2} \right] = \frac{1}{3} \sqrt{(4)^2 - (2)^2} = \frac{1}{3} \sqrt{16 - 4} = \frac{1}{3} \sqrt{12} = \frac{1}{3} \times 2\sqrt{3}$$

$$\therefore \text{Area of square} = 2 \left( \frac{2}{\sqrt{3}} \right)^2 = \frac{8}{3} \text{ sq. units}$$

**ILLUSTRATION 57:** Can the sides of a quadrilateral (not necessarily taken in order) be in  $AP$  in which a circle can be inscribed?

**SOLUTION:**  $\{EB = BF; AE = AH; DG = DH; GC = CF\}$  Adding we get

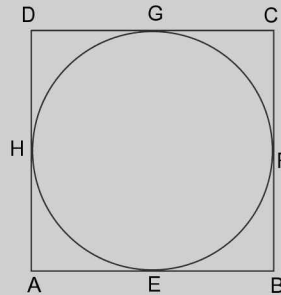

**FIGURE 3.61**

$$AB + DC = BC + AD$$

which is not possible if the sides are in  $AP$  in order, as  $AB = a$ ,  $BC = a + d$ ,  $CD = a + 2d$ ,  $AD = a + 3d \Rightarrow AB + CD = 2a + 2d$  where as  $BC + AD = 2a + 4d$  but possible if they are in any order.

e.g., if  $AB = a - 3d$ ,  $CD = a + 3d$

$$BC = a - d \text{ and } AD = a + d, \text{ then } AB + CD = BC + AD = 2a$$

## TEXTUAL EXERCISE-5 (SUBJECTIVE)

- Find the sum of the radii of inscribed and circumscribed circles for an  $n$  sided regular polygon of side  $a$ .
- The area of a circle is  $A_1$  and area of a regular pentagon inscribed in the circle is  $A_2$ . Then find the ratio  $A_1 : A_2$ .
- Find the ratio of area of the circle and the regular polygon of  $n$  sides and of equal perimeter.
- A circle is inscribed in an equilateral triangle of side  $a$ . Find the area of any square inscribed in the circle.
- Three equal circles each of radius  $r$  touch one another. Find the radius of the circle touching all the three given circles internally.
- If the lengths of medians  $AD$ ,  $BE$ ,  $CF$  of  $\Delta ABC$  are  $l_1$ ,  $l_2$  and  $l_3$  respectively. Then show that  $\frac{3}{2}s < \sum l_i < 3s$ .
- In a  $\Delta ABC$ , find the minimum value of  $\tan^2(A/2) + \tan^2(B/2) + \tan^2(C/2)$ .
- If  $a_1, a_2, \dots, a_n$  are the sides of polygon  $A_1A_2A_3 \dots A_n$  then show that  $\frac{a_1^2 + a_2^2 + \dots + a_{n-1}^2}{a_n^2} > \frac{1}{n-1}$ .
- In a  $\Delta ABC$ ,  $\angle A = 30^\circ$ ,  $BC = 2 + \sqrt{5}$ , then distance of vertex  $A$  from orthocenter of  $\Delta$  is  $(\sqrt{k} + \sqrt{k+1})\sqrt{k-1}$  then  $k$  equals
- $I_n$  is the area of  $n$  sided regular polygon inscribed in a circle of unit radius and  $O_n$  be the area of the polygon circumscribing the given circle, prove that  $I_n = \frac{O_n}{2} \left( 1 + \sqrt{1 - \left( \frac{2I_n}{n} \right)^2} \right)$

**3.50** > Trigonometry

11. Show that in any triangle the distance  $d$  between the in-centre  $I$  and circum-centre  $S$  is given by  $d^2 = R^2 - 2rR$  where  $R$  is the circum-radius and  $r$  is the in-radius.
12. Let  $ABC$  be a triangle with altitudes  $h_1, h_2, h_3$  and in-radius  $r$ . Prove that  $\frac{h_1+r}{h_1-r} + \frac{h_2+r}{h_2-r} + \frac{h_3+r}{h_3-r} \geq 6$
13. Three circles whose radii are  $a, b, c$  touch one another externally, and the tangents at their point of contact meet in a point. Prove that the distance of this point from either of their points of contact is  $\left(\frac{abc}{a+b+c}\right)^{1/2}$
14.  $A_1A_2A_3 \dots A_n$  is a regular polygon of  $n$  sides circumscribed to a circle of centre  $O$  and radius  $a$ .  $P$  is any point distant  $c$  from  $O$ . Show that the sum of the squares of the perpendiculars from  $P$  on the sides of the polygon is  $n \left(a^2 + \frac{c^2}{2}\right)$
15. In a  $\Delta ABC$ ,  $r_A, r_B, r_C$  are the radii of the circles which touch the incircle and the sides emanating from the vertices  $A, B, C$  respectively. Prove that  $\sqrt{r_A r_B} + \sqrt{r_B r_C} + \sqrt{r_C r_A} = r$
16. Let points  $P_1, P_2, \dots, P_{n-1}$  divide the side  $BC$  of triangle  $ABC$  into  $n$  parts. Let  $r_1, r_2, \dots, r_n$  be the radii of inscribed circles and let  $p_1, p_2, \dots, p_n$  be the radii of escribed circles corresponding to vertex  $A$  for the triangles  $ABP_1, AP_1P_2, AP_{n-1}C$  and let  $r$  and  $p$  be the corresponding radii for the  $\Delta ABC$ . Show that :  $\frac{r_1}{p_1} \cdot \frac{r_2}{p_2} \dots \frac{r_n}{p_n} = \frac{r}{p}$

**Answer Keys**

1.  $\frac{a}{2} \cot\left(\frac{\pi}{2n}\right)$       2.  $\frac{2\pi}{5} \operatorname{cosec}\left(\frac{2\pi}{5}\right)$       3.  $\tan\left(\frac{\pi}{n}\right) : \frac{\pi}{n}$       4.  $\frac{a^2}{6}$       5.  $\frac{(2+\sqrt{3})r}{\sqrt{3}}$
7. 1      9. 4

**TEXTUAL EXERCISE-5 (OBJECTIVE)**

1. In an acute angled triangle  $ABC$ ,  $AD$  and  $AM$  are the median and altitude respectively. Then  $DM =$
- (a)  $\frac{|a^2 - b^2|}{2c}$       (b)  $\frac{|c^2 - b^2|}{2a}$
- (c)  $\frac{|a^2 - c^2|}{2b}$       (d) None of these
2. In a  $\Delta ABC$ ,  $AD, BE$  and  $CF$  are the altitudes and  $R$  is the circum radius, then the radius of the circle  $DEF$  is
- (a)  $R/3$       (b)  $R/4$
- (c)  $R/2$       (d) None of these
3. A right angled  $\Delta ABC$  of maximum area is inscribed in a circle of radius  $R$ , then which of the following statements is correct?
- (a)  $\Delta = R^2$
- (b)  $r = (\sqrt{2} - 1)R$
- (c)  $\frac{1}{r_1} + \frac{1}{r_2} + \frac{1}{r_3} = \frac{\sqrt{2} - 1}{R}$
- (d)  $s = (1 + \sqrt{2})R$
4. A circular ring of radius 5 cm is suspended horizontally from a point 12 cm vertically above the centre by 4 strings attached at equal intervals to its circumference. If the angle between two consecutive strings be  $\theta$ , then  $\sqrt{\cos \theta}$  is:
- (a)  $\frac{5}{12}$       (b)  $\frac{12}{13}$
- (c)  $\frac{5}{13}$       (d) None of these
5.  $k$  non-overlapping regular polygons of  $n_1, n_2, \dots, n_k$  sides have one vertex in common so that no gap is left at that vertex, then  $\sum_{i=1}^k \frac{1}{n_i}$  is equal to
- (a)  $k/2$       (b)  $(k - 2)/2$
- (c)  $(k + 2)/2$       (d) None of these
6. The area of cyclic quadrilateral  $PQRS$  is  $4\sqrt{3}$  units. The radius of the circumcircle of  $\Delta PQR$  is 2. If  $PQ = 2$ ,  $QS = 2\sqrt{3}$ , then the value of product  $QR$  and  $RS$  is
- (a) 12      (b) 8
- (c)  $8\sqrt{3}$       (d) None of these

7. The sides of a triangle inscribed in a given circle subtend angle  $\psi, \theta, \phi$  at the centre. The minimum value of the A.M. of  $\cos\left(\psi + \frac{\pi}{2}\right), \cos\left(\theta + \frac{\pi}{2}\right), \cos\left(\phi + \frac{\pi}{2}\right)$  is equal to:
- (a)  $\frac{3}{2}$  (b)  $\frac{\sqrt{3}}{2}$   
 (c)  $-\frac{\sqrt{3}}{2}$  (d) None of these
8. For a regular polygon, let  $r$  and  $R$  be the radii of the inscribed and the circumscribed circles. A false statement among the following is
- (a) There is a regular polygon with  $\frac{r}{R} = \frac{\sqrt{3}}{2}$   
 (b) There is a regular polygon with  $\frac{r}{R} = \frac{1}{2}$   
 (c) There is a regular polygon with  $\frac{r}{R} = \frac{1}{\sqrt{2}}$   
 (d) There is a regular polygon with  $\frac{r}{R} = \frac{2}{3}$
9. Let  $A, A_1, A_2, A_3$  be the areas of the inscribed and escribed circles of  $\Delta ABC$ , then:
- (a)  $\sqrt{A_1} + \sqrt{A_2} + \sqrt{A_3} = \sqrt{\pi}(r_1 + r_2 + r_3)$   
 (b)  $\sqrt{A_1} + \sqrt{A_2} + \sqrt{A_3} = \sqrt{\pi}(4R + r)$   
 (c)  $\frac{1}{\sqrt{A_1}} + \frac{1}{\sqrt{A_2}} + \frac{1}{\sqrt{A_3}} = \frac{1}{\sqrt{A}}$   
 (d)  $\frac{1}{\sqrt{A_1}} + \frac{1}{\sqrt{A_2}} + \frac{1}{\sqrt{A_3}} = \frac{s^2}{\sqrt{\pi \cdot r_1 \cdot r_2 \cdot r_3}}$
10. Let  $H$  be the orthocentre of triangle  $ABC$  then angle subtended by side  $BC$  at the centre of in-circle of  $\Delta CHB$  is:
- (a)  $\frac{A}{2} + 90$  (b)  $\frac{B+C}{2} + 90$   
 (c)  $\frac{B-C}{2} + 90$  (d) None of these
11. A point  $\theta$  is selected at random inside the equilateral triangle. If sum of lengths of perpendicular dropped on sides from  $Q$  is  $P$ , then length of altitude of  $\Delta$  is-
- (a)  $\frac{P}{2}$  (b)  $\frac{P}{3}$   
 (c)  $P$  (d) None of these
12. If the diameter of an ex-circle be equal to the perimeter of the triangle then the triangle is-
- (a) Right angled  
 (b) Isosceles  
 (c) Right angled isosceles  
 (d) Equilateral
13. A regular polygon of nine sides, each of length 2 is inscribed in a circle. The radius of the circle is
- (a)  $\operatorname{cosec}\left(\frac{\pi}{9}\right)$  (b)  $\operatorname{cosec}\left(\frac{\pi}{3}\right)$   
 (c)  $\cot\left(\frac{\pi}{9}\right)$  (d)  $\tan\left(\frac{\pi}{9}\right)$
14. A pole stands vertically inside a triangular part  $\Delta ABC$ . If the angle of elevation of the top of the pole from each corner of the part is same, then in  $\Delta ABC$  the foot of the pole is at the
- (a) centroid (b) circumcentre  
 (c) incentre (d) orthocentre
15. If distance between incentre & one of the excentre of equilateral triangle is 4 unit. Then inradius of triangle is:
- (a) 2 unit (b) 1 unit  
 (c)  $\sqrt{\frac{3}{2}}$  unit (d)  $\frac{1}{2}$  unit
16. If  $r_1, r_2, r_3$  are the radii of the escribed circles of a triangle  $ABC$  and  $r$  is the radius of its incircle then the root(s) of the equation  $x^2 - r(r_1r_2 + r_2r_3 + r_3r_1)x + r_1r_2r_3 - 1 = 0$  is/are
- (a) 1 (b)  $r_1 + r_2 + r_3$   
 (c)  $r$  (d)  $r_1r_2r_3 - 1$

## Answer Keys

1. (b) 2. (c) 3. (a, b, d) 4. (b) 5. (b) 6. (a, b) 7. (c) 8. (d) 9. (a, b, c, d)  
 10. (b) 11. (c) 12. (a) 13. (a) 14. (b) 15. (b) 16. (a, d)

## MULTIPLE CHOICE QUESTIONS

### SECTION-I

#### OBJECTIVE SOLVED EXAMPLES

1. In a triangle if  $r_1 > r_2 > r_3$ , then

- (a)  $a > b > c$                       (b)  $a < b < c$   
 (c)  $a > b$  and  $b < c$             (d)  $a < b$  and  $b > c$

**Solution:** (a) We have  $r_1 > r_2 > r_3$

$$\Rightarrow \frac{\Delta}{s-a} > \frac{\Delta}{s-b} > \frac{\Delta}{s-c}$$

$$\text{Dividing each by } \Delta, \text{ then } \frac{1}{s-a} > \frac{1}{s-b} > \frac{1}{s-c}$$

$$\Rightarrow s-a < s-b < s-c \text{ (subtracting } s \text{ from each)}$$

$$\Rightarrow -a < -b < -c \Rightarrow a > b > c$$

2. If in a  $\Delta ABC$ ;  $\sin C + \cos C + \sin(2B + C) - \cos(2B + C) = 2\sqrt{2}$ , then

- (a) triangle is right angled  
 (b) triangle is equilateral  
 (c) triangle is isosceles  
 (d) triangle is isosceles right angled

**Solution:** (d) We have

$$\sin C + \cos C + \sin(2B + C) - \cos(2B + C) = 2\sqrt{2}$$

$$\Rightarrow [\sin(2B+C) + \sin C] + [\cos C - \cos(2B+C)] = 2\sqrt{2}$$

$$\Rightarrow 2\sin(B+C) \cos B + 2\sin(B+C) \sin B = 2\sqrt{2}$$

$$\Rightarrow \sin(180^\circ - A) \cos B + \sin(180^\circ - A) \sin B = \sqrt{2}$$

$$\Rightarrow \sin A (\cos B + \sin B) = \sqrt{2}$$

$$\Rightarrow \sin A \left( \frac{1}{\sqrt{2}} \cos B + \frac{1}{\sqrt{2}} \sin B \right) = 1$$

$$\Rightarrow \sin A \sin \left( \frac{\pi}{4} + B \right) = 1$$

$$\text{It is possible only when } \sin A = 1 \text{ and } \sin \left( \frac{\pi}{4} + B \right) = 1$$

$$\Rightarrow \angle A = 90^\circ \text{ and } \angle B = 45^\circ \text{ then } \angle C = 45^\circ$$

Hence  $\Delta ABC$  is isosceles right angled triangle.

3. The radius of the circle passing through the centre of incircle of  $ABC$  and through the end points of  $BC$  is given by

(a)  $\frac{a}{2}$                                       (b)  $\frac{a}{2} \sec A/2$

(c)  $\frac{a}{2} \sin A$                             (d)  $a \sec A/2$

**Solution:** (b)  $\angle BIC + \angle BDC = 180^\circ$

$$\therefore \angle BDC = 90^\circ - A/2 \quad (\because \angle BIC = 90^\circ + A/2)$$

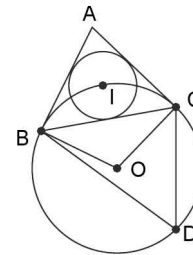

Let  $O$  be the centre of the required circle and  $R_1$  is the radius.

$$\text{Then } \angle BOC = 2 \angle BDC = (180^\circ - A) ; \quad BC = a.$$

In  $\Delta BOC$ ,

$$\cos(180^\circ - A) = \frac{R_1^2 + R_1^2 - a^2}{2R_1R_1}$$

$$\Rightarrow -2R_1^2 \cos A = 2R_1^2 - a^2$$

$$\Rightarrow a^2 = 2R_1^2(1 + \cos A) \Rightarrow a^2 = 4R_1^2 \cos^2 A/2$$

$$\Rightarrow R_1^2 = \frac{a^2}{4} \sec^2 A/2 \Rightarrow R_1 = \frac{a}{2} \sec A/2$$

4. Three equal circles each of radius  $r$  touch one another. The radius of the circle touching all the three given circles is

(a)  $(2 + \sqrt{3})r$                       (b)  $\frac{(2 + \sqrt{3})r}{\sqrt{3}}$

(c)  $\frac{(2 - \sqrt{3})r}{\sqrt{3}}$                             (d)  $(2 - \sqrt{3})r$

**Solution:** (b, c)  $\Delta DEF$  is equilateral with side  $2r$ , let the radius of circum-circle of triangle  $DEF$  be  $R_1$ .

$$\text{Now, area of } \Delta DEF = \frac{\sqrt{3}}{4} (2r)^2 = \sqrt{3} r^2$$

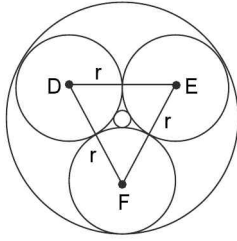

$$\Rightarrow \sqrt{3} r^2 = \frac{2r \cdot 2r \cdot 2r}{4R_1} \Rightarrow R_1 = \frac{2r}{\sqrt{3}} \left( \because \Delta = \frac{abc}{4R} \right)$$

Radius of the circle touching all the three given circles =  $R_1 + r$  or  $R_1 - r$

$$= r + \frac{2r}{\sqrt{3}} = \frac{(2 + \sqrt{3})r}{\sqrt{3}} \text{ or } = \frac{(2 - \sqrt{3})r}{\sqrt{3}}$$

5. The perimeter of a  $\Delta ABC$  is 6 times the arithmetic mean of the sines of its angles. If the side  $a$  is 1, then the angle  $A$  is

- (a)  $\pi/6$  (b)  $\pi/3$   
 (c)  $\pi/2$  (d)  $\pi$

**Solution:** (a) We have,

$$a + b + c = \frac{6(\sin A + \sin B + \sin C)}{3}$$

$$\Rightarrow k(\sin A + \sin B + \sin C) = 2(\sin A + \sin B + \sin C).$$

$$\text{where } k = \frac{a}{\sin A} = \frac{b}{\sin B} = \frac{c}{\sin C}$$

$$\Rightarrow k = 2 \left[ \because \sin A + \sin B + \sin C \neq 0 \right]$$

$$\Rightarrow \frac{a}{\sin A} = 2 \Rightarrow \sin A = 1/2 \Rightarrow A = \pi/6$$

6. If  $\cot \frac{A}{2} = \frac{b+c}{a}$ , then the  $\Delta ABC$  is

- (a) isosceles (b) equilateral  
 (c) right angled (d) None of these

**Solution:** (c)

$$\cot \frac{A}{2} = \frac{b+c}{a} \Rightarrow \frac{\cos A/2}{\sin A/2} = \frac{\sin B + \sin C}{\sin A}$$

$$\Rightarrow \frac{\cos A/2}{\sin A/2} = \frac{2 \sin \left( \frac{B+C}{2} \right) \cos \left( \frac{B-C}{2} \right)}{2 \sin \frac{A}{2} \cos \frac{A}{2}}$$

$$\Rightarrow \cos \frac{A}{2} \cos \left( \frac{B-C}{2} \right)$$

$$\Rightarrow \frac{A}{2} = \frac{B-C}{2} \Rightarrow A = B - C$$

$$\Rightarrow A + C = B$$

$$\text{But } A + B + C = \pi. \text{ Therefore, } B = \frac{\pi}{2}$$

7. If  $c^2 = a^2 + b^2$ ,  $2s = a + b + c$ , then  $4s(s-a)(s-b)(s-c)$  is equal to

- (a)  $s^4$  (b)  $b^2 c^2$   
 (c)  $c^2 a^2$  (d)  $a^2 b^2$

$$\text{Solution: (d) } c^2 = a^2 + b^2 \Rightarrow \angle C = \frac{\pi}{2}$$

$$\therefore \Delta = \frac{1}{2} ab \sin C = \frac{1}{2} ab$$

$$\Rightarrow \sqrt{s(s-a)(s-b)(s-c)} = \frac{1}{2} ab$$

$$\Rightarrow 4s(s-a)(s-b)(s-c) = a^2 b^2$$

8. In a triangle the length of the two larger sides are 24 and 22, respectively. if the angles are in AP, then the third side is

- (a)  $12 + 2\sqrt{13}$  (b)  $12 - 2\sqrt{13}$   
 (c)  $2\sqrt{3} + 2$  (d)  $2\sqrt{3} - 2$

**Solution:** (a, b) As the angles are in AP, therefore

$$2B = A + C \Rightarrow 3B = A + B + C \Rightarrow B = 60^\circ$$

$$\Rightarrow A + C = 120^\circ$$

Therefore either  $a$  is the smallest side or  $c$  is smallest side. Let  $c$  be the smallest side. Then the two larger sides are  $a$  and  $b$ . Let  $a = 24$ ,  $b = 22$

$$\text{Now, } B = 60^\circ \Rightarrow \cos B = 1/2 \Rightarrow \frac{c^2 + a^2 - b^2}{2ac} = \frac{1}{2}$$

$$\Rightarrow \frac{c^2 + 576 - 484}{48c} = \frac{1}{2} \Rightarrow c = 12 \pm 2\sqrt{13}$$

9. In a  $\Delta ABC$ ,  $a, c, A$  are given and  $b_1, b_2$  are two values of the third side  $b$  such that  $b_2 = 2b_1$ . Then  $\sin A =$

- (a)  $\sqrt{\frac{9a^2 - c^2}{8a^2}}$  (b)  $\sqrt{\frac{9a^2 - c^2}{8c^2}}$   
 (c)  $\sqrt{\frac{9a^2 + c^2}{8a^2}}$  (d) None of these

$$\text{Solution: (b) We have: } \cos A = \frac{b^2 + c^2 - a^2}{2bc}$$

$$\Rightarrow b^2 - 2bc \cos A + (c^2 - a^2) = 0 \text{ (quadratic in } b)$$

It is given that  $b_1$  and  $b_2$  are roots of this equation.

$$\text{Therefore } b_1 + b_2 = 2c \cos A \text{ and } b_1 b_2 = c^2 - a^2.$$

3.54 > Trigonometry

$$\Rightarrow 3b_1 = 2c \cos A \text{ and } 2b_1^2 = c^2 - a^2$$

[  $b_2$   $2b_1$  given ]

$$\Rightarrow 2(-\cos A) = c^2 - a^2$$

$$\Rightarrow 8c^2(1 - \sin^2 A) = 9c^2 - 9a^2$$

$$\Rightarrow \sin A = \sqrt{\frac{a^2 - c^2}{c^2}} \quad (\text{In a } \Delta \sin A > 0)$$

10. In a  $\Delta ABC$ ,  $a, b, A$  are given and  $c_1, c_2$  are two values of the third side  $c$ . The sum of the areas of two triangles with sides  $a, b, c_1$  and  $a, b, c_2$  is
- (a)  $(1/2) b^2 \sin 2A$       (b)  $(1/2) a^2 \sin 2A$   
 (c)  $b^2 \sin 2A$               (d) None of these

**Solution:** (a) Since we know that

$$\cos A = \frac{c^2 + b^2 - a^2}{2bc} \Rightarrow c^2 - 2bc \cos A + b^2 - a^2 = 0$$

It is given that  $c_1$  and  $c_2$  are roots of the equation.

$$\text{Therefore, } c_1 + c_2 = 2b \cos A$$

$$\text{and } c_1 c_2 = b^2 - a^2$$

$$\Rightarrow k(\sin C_1 + \sin C_2) = 2k \sin B \cos A$$

( $\because \sin B_1 = \sin B_2 = \sin B$  (say))

$$\Rightarrow \sin C_1 + \sin C_2 = 2 \sin B \cos A$$

Now, sum of the areas of two triangles

$$= \frac{1}{2} ab \sin C_1 + \frac{1}{2} ab \sin C_2$$

$$\Rightarrow \frac{1}{2} ab (\sin C_1 + \sin C_2) = \frac{1}{2} ab (2 \sin B \cos A)$$

$$= ab \sin B \cos A = (b^2 \sin A) \cos A = \frac{1}{2} b^2 \sin 2A.$$

11. If the area of a  $\Delta ABC$  be  $\lambda$ , then  $a^2 \sin 2B + b^2 \sin 2A$  is equal to
- (a)  $2\lambda$                               (b)  $4\lambda$   
 (c)  $\lambda$                                 (d) None of these

**Solution:** (b)  $a^2 \sin 2B + b^2 \sin 2A = 2a^2 \sin B \cdot \cos B + 2b^2 \sin A \cos A$

$$= \frac{a^2 b}{R} \cos B + \frac{b^2 a}{R} \cos A$$

$$\left( \because \frac{\sin A}{a} = \frac{1}{2R} = \frac{\sin B}{b} \right)$$

$$= \frac{ab}{R} (a \cos B + b \cos A) = \frac{abc}{R} = 2bc \sin A$$

$$= 4 \left( \frac{1}{2} bc \sin A \right) = 4\lambda$$

12. In a  $\Delta ABC$ ,  $B = \pi/8$  and  $C = 5\pi/8$ , then length of altitude ( $p$ ) dropped from  $A$  is
- (a)  $a/\sqrt{2}$                               (b)  $2a$   
 (c)  $1/2(b+c)$                       (d) None of these

**Solution:** (a)

$$\frac{1}{2} pa = \text{area} = \frac{1}{2} bc \sin \frac{\pi}{4}; \quad \therefore p = \frac{bc}{a\sqrt{2}}$$

$$\text{Also } \frac{a}{\sin \frac{\pi}{4}} = \frac{b}{\sin \frac{\pi}{8}} = \frac{c}{\sin \frac{5\pi}{8}}$$

$$\Rightarrow b = \sqrt{2}a \sin \frac{\pi}{8}, c = \sqrt{2}a \sin \frac{5\pi}{8}$$

$$\therefore p = \frac{2a^2 \sin \frac{\pi}{8} \sin \frac{5\pi}{8}}{a\sqrt{2}} = \frac{a}{\sqrt{2}}$$

$$\left[ \because \left( \cos \frac{4\pi}{8} - \cos \frac{6\pi}{8} \right) = \frac{1}{\sqrt{2}} \right]$$

13. In a  $\Delta ABC$ , the line segments  $AD, BE$  and  $CF$  are three altitudes. If  $R$  is the circumradius of the  $\Delta ABC$ , then a side of the  $\Delta DEF$  will be
- (a)  $R \sin 2A$                               (b)  $\cos B$   
 (c)  $a \sin A$                               (d)  $b \cos B$

**Solution:** (a, d) From Geometry

$$\angle AOF = B, \angle AOE = C$$

$$\text{Also } OF = b \cos A \tan(90^\circ - B)$$

$$= b \cos A \cot B = 2R \cos A \cos B.$$

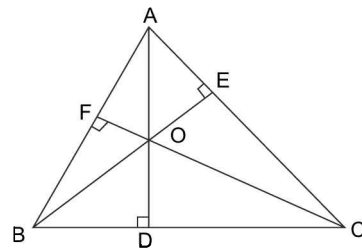

Similarly,  $OE = 2R \cos A \cos C.$

$$\text{In } \Delta OEF, \cos(B+C) = \frac{OE^2 + OF^2 - EF^2}{2 \cdot OE \cdot OF}$$

$$\Rightarrow -\cos A = \frac{4R^2 \cos^2 A (\cos^2 B + \cos^2 C) - EF^2}{8R^2 \cos^2 A \cos B \cos C}$$

$$\Rightarrow EF^2 = 4R^2 \cos^2 A [\cos^2 B + \cos^2 C + 2 \cos A \cos B \cos C]$$

$$= 4R^2 \cos^2 A \sin^2 A$$

(because in  $\Delta ABC$   $\cos^2 B + \cos^2 C + \cos^2 A = 1 - 2\cos A \cos B \cos C$ )

$$\therefore EF = R \sin 2A = \frac{a}{2 \sin A} \sin 2A = a \cos A.$$

Similarly,  $DF = b \cos B$ .

14. The sides of a triangle are in the ratio 3 : 4 : 5, the relation between  $r$  and  $R$  for the triangle is

- (a)  $r = \frac{R}{2}$                       (b)  $r = \frac{2R}{5}$   
 (c)  $r = \frac{R}{5}$                       (d) None of these

**Solution:** (b) Clearly, the  $\Delta$  is a right angled triangle. Let the sides be  $3k, 4k$  and  $5k$ . The area of the triangle

$$\frac{(3k)(4k)}{2} = 6k^2$$

$$\text{Semi perimeter} = 6k \Rightarrow r = \frac{6k^2}{6k} = k \text{ and } R = \frac{5k}{2}$$

$$\Rightarrow R = \frac{5r}{2} \text{ or } r = \frac{2R}{5}$$

15. In any triangle  $ABC$ ,  $\frac{a^2 + b^2 + c^2}{R^2}$  has the maximum value

- (a) 3                                      (b) 6  
 (c) 9                                      (d) None of these

**Solution:** (c) In triangle  $ABC$ ,  $\frac{a^2 + b^2 + c^2}{R^2} = 4$

$$[\sin^2 A + \sin^2 B + \sin^2 C]$$

$$= 8 [1 + \cos A \cos B \cos C] \leq 8 \left[1 + \frac{1}{8}\right] = 9$$

16. In a triangle  $ABC$ , if  $P, Q, R$  divide sides  $BC, CA$  and  $AB$  respectively in the ratio  $k:1$  (in order). If the ratio  $\left(\frac{\text{area } PQR}{\text{area } ABC}\right)$  is  $\frac{1}{3}$ , then  $k$  is equal to

- (a) 1                                      (b) 2  
 (c)  $1/2$                                   (d) None of these

**Solution:** (b,c) Area of triangle

$$ARQ = \frac{b}{(k+1)} \cdot \frac{kc}{(k+1)} \cdot \frac{1}{2} \sin A \Rightarrow \frac{k\Delta}{(k+1)^2}$$

$$\text{Similarly, } ar(\Delta BPR) = ar(\Delta PCQ) = \frac{k\Delta}{(k+1)^2}$$

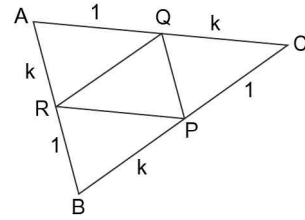

$$\Rightarrow ar(\Delta PQR) = \Delta - \frac{3k\Delta}{(k+1)^2} = \left(\frac{k^2 - k + 1}{k^2 + 2k + 1}\right)\Delta$$

$$\text{Ratio} = \left(\frac{k^2 - k + 1}{k^2 + 2k + 1}\right) = \frac{1}{3} \Rightarrow k = 2 \text{ or } k = 1/2$$

17. In a right angled triangle, the acute angles  $\alpha, \beta$  are satisfying  $\tan \alpha + \tan \beta + \tan^2 \alpha + \tan^2 \beta = 4$ . If the hypotenuse is of length ' $d$ ', then the area of the triangle is

- (a)  $\frac{\sqrt{3}}{4} d^2$                       (b)  $\frac{\sqrt{3}}{8} d^2$   
 (c)  $\frac{d^2}{4}$                                   (d) None of these

**Solution:** (c) Here  $\alpha + \beta = 90^\circ$  and  $\tan \alpha + \cot \alpha + \tan^2 \alpha + \cot^2 \alpha = 4$  (given)

$$\text{Let } \tan \alpha = y \Rightarrow \left(y + \frac{1}{y}\right) + \left(y^2 + \frac{1}{y^2}\right) = 4$$

$$\left[\because x + \frac{1}{x} \geq 2 \forall x > 0 \text{ and } x + \frac{1}{x} = 2 \text{ for } x = 1\right]$$

$$\Rightarrow y = 1 \Rightarrow \alpha = \beta = \frac{\pi}{4}$$

Hence area of an isosceles right angles triangle =  $\frac{d^2}{4}$ .

18. If in a triangle  $\frac{r}{r_1} = \frac{r_2}{r_3}$ , where  $r, r_1, r_2, r_3$  have their usual meanings, then

- (a)  $A = 90^\circ$                       (b)  $B = 90^\circ$   
 (c)  $C = 90^\circ$                       (d) None of these

**Solution:** (c) Given that  $\frac{r}{r_1} = \frac{r_2}{r_3}$

$$\Rightarrow \frac{\Delta(s-a)}{s\Delta} = \frac{\Delta(s-c)}{(s-b)\Delta}$$

$$\Rightarrow (s-a)(s-b) = s(s-c)$$

$$\Rightarrow ab = s(a+b-c)$$

$$\Rightarrow a^2 + b^2 = c^2 \Rightarrow \text{the triangle is right angled at } C.$$



3.56 > Trigonometry

19. If the sides  $a, b, c$  of a triangle  $ABC$  are respectively

$$k \left( \sqrt{\cot \frac{B}{2} \cot \frac{C}{2} - 1} \right) \cos \frac{A}{2},$$

$$k \left( \sqrt{\cot \frac{C}{2} \cot \frac{A}{2} - 1} \right) \cos \frac{B}{2},$$

and  $k \left( \sqrt{\cot \frac{A}{2} \cot \frac{B}{2} - 1} \right) \cos \frac{C}{2}$ , then  $k$  is equal to

(a)  $2\sqrt{Rr}$  (b)  $2(R+r)$

(c)  $2(R-r)$  (d)  $\frac{R}{r}$

**Solution:** (a) In  $\triangle ABC$ ,  $a = 2R \sin A$

$$\Rightarrow k \left( \sqrt{\cot \frac{B}{2} \cot \frac{C}{2} - 1} \right) \cos \frac{A}{2} = 4R \sin \frac{A}{2} \cos \frac{A}{2}$$

$$\Rightarrow k = 4R \sqrt{\sin \frac{A}{2} \sin \frac{B}{2} \sin \frac{C}{2}} \Rightarrow k = 2\sqrt{Rr}$$

20. If  $a, b, c$ , are the sides of a triangle, then the minimum

value of  $\frac{a}{b+c-a} + \frac{b}{c+a-b} + \frac{c}{a+b-c}$  is equal to

(a) 3 (b) 6

(c) 9 (d) 12

**Solution:** (a) Given expression is

$$\frac{1}{2} \sum \frac{2a}{b+c-a} = \frac{1}{2} \sum \left( \frac{2a}{b+c-a} + 1 \right) - \frac{3}{2}$$

$$= \frac{1}{2} (a+b+c) \sum \left( \frac{1}{b+c-a} \right) - \frac{3}{2}$$

Now, as  $(a+b+c) = \sum(b+c-a)$ .

Applying A.M.  $\geq$  H.M.

$$\text{Minimum value of the expression} = \frac{1}{2} \times 9 - \frac{3}{2} = 3$$

21. Let in  $\triangle ABC$ ,  $x, y, z$  are the lengths of altitudes drawn from  $A, B, C$  respectively. If  $x, y, z$  are in A.P. then

(a)  $\cos A, \cos B, \cos C$  are in A.P.

(b)  $\cos A, \cos B, \cos C$  are in H.P.

(c)  $\sin A, \sin B, \sin C$  are in H.P.

(d)  $\sin A, \sin B, \sin C$  are in A.P.

**Solution:** (c)  $\Delta = \frac{1}{2} ax \Rightarrow x = \frac{2\Delta}{a} = \frac{2\Delta}{2R \sin A} = \frac{\Delta}{R \sin A}$

Similarly,  $y = \frac{\Delta}{R \sin B}, z = \frac{\Delta}{R \sin C}$

Given  $x, y, z$  are in A.P.

$$\Rightarrow \frac{\Delta}{R \sin A}, \frac{\Delta}{R \sin B}, \frac{\Delta}{R \sin C} \text{ are in A.P.}$$

$$\Rightarrow \sin A, \sin B, \sin C \text{ are in H.P.}$$

22. In triangle  $ABC$  if  $\angle A = 60^\circ$  and  $AD$  is the angle bisector,  $D$  is point of  $BC$ , then length  $AD$  is equal to

(a)  $\frac{bc}{b+c}$

(b)  $\frac{2bc}{b+c}$

(c)  $\frac{\sqrt{3}bc}{b+c}$

(d) None of these

**Solution:** (c) Area of  $\triangle ABC = \text{Area of } \triangle ABD + \text{Area of } \triangle ADC$

$$\Rightarrow \frac{1}{2} bc \sin 60^\circ = \frac{1}{2} c \cdot AD \sin 30^\circ + \frac{1}{2} b \cdot AD \sin 30^\circ$$

$$\Rightarrow bc \frac{\sqrt{3}}{2} = \frac{1}{2} (b+c) AD \Rightarrow AD = \frac{\sqrt{3}bc}{b+c}$$

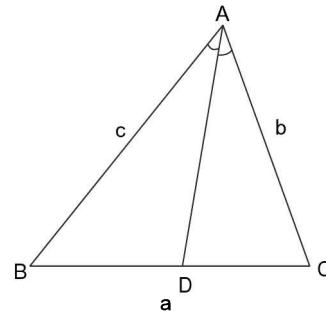

23. In an acute angled triangle  $ABC$  if  $\cos A, 1 - \cos B, \cos C$  are in A.P. and  $\sin A + \sin C = 1$ , then  $\angle B$  is equal to

(a)  $\frac{\pi}{4}$

(b)  $\frac{\pi}{3}$

(c)  $\frac{\pi}{6}$

(d) None of these

**Solution:** (c) Given  $\cos A + \cos C = 2(1 - \cos B)$

$$\Rightarrow 2 \cos \frac{A+C}{2} \cos \frac{A-C}{2} = 4 \sin^2 \frac{B}{2}$$

$$\Rightarrow \sin \frac{B}{2} \left[ \cos \frac{A-C}{2} - 2 \cos \frac{A+C}{2} \right] = 0 \text{ as}$$

$$\sin \frac{B}{2} \neq 0 \text{ so } \cos \frac{A-C}{2} = 2 \sin \frac{B}{2}$$

multiplying both sides by  $2 \cos \frac{B}{2}$ , we get

$$2 \cos \frac{B}{2} \cos \frac{A-C}{2} = 2 \sin B$$



3.58 > Trigonometry

**Solution:** (b)  $\sin\theta + \cos\theta = \frac{b}{a}$  ;  $\sin\theta - \cos\theta = \frac{c}{a}$

$\therefore (\sin\theta + \cos\theta)^2 = 1 + 2\sin\theta \cos\theta = 1 + 2 \cdot \frac{c}{a}$

$\Rightarrow \frac{b^2}{a^2} = 1 + 2 \frac{c}{a}$

$\Rightarrow b^2 = a^2 + 2ac$

$\Rightarrow b^2 - a^2 = 2ac$

Now  $\cos B = \frac{a^2 + c^2 - b^2}{2ac} = \frac{c^2 - (b^2 - a^2)}{2ac} = \frac{c^2 - 2ac}{2ac}$   
 $= \left( \frac{c}{2a} - 1 \right)$

30. In a  $\Delta ABC$  if  $r_1 = 2r_2 = 3r_3$ , then which are correct?

- (a)  $\cos B = 9/15$  (b)  $\cos C = 4/5$   
 (c)  $\Delta ABC$  is a rt.  $\Delta$  (d) None of these

**Solution:** (a,b,c)  $r_1 = 2r_2 = 3r_3 = k$  (say)

$\Rightarrow r_1 = k$  ;  $r_2 = \frac{k}{2}$  ;  $r_3 = \frac{k}{3}$

$\Rightarrow \frac{\Delta}{s-a} = k$  ;  $\frac{\Delta}{s-b} = \frac{k}{2}$  ;  $\frac{\Delta}{s-c} = \frac{k}{3}$

$\Rightarrow (s-a) = \frac{\Delta}{k}$  ;  $s-b = \frac{2\Delta}{k}$  ;  $s-c = \frac{3\Delta}{k}$

$\Rightarrow (s-a) = \lambda$  ;  $s-b = 2\lambda$  ;  $s-c = 3\lambda$  ; where  $\lambda = \Delta/k$

Adding we get,  $3s - (a + b + c) = 6\lambda$

$\Rightarrow 3s - 2s = 6\lambda \Rightarrow s = 6\lambda$

$\Rightarrow a = 5\lambda$  ;  $b = 4\lambda$  ;  $c = 3\lambda$

$\therefore \cos A = \frac{b^2 + c^2 - a^2}{2bc}$  ;  $\cos B = \frac{a^2 + c^2 - b^2}{2ac}$  ;

$\cos C = \frac{a^2 + b^2 - c^2}{2ab}$

$\Rightarrow \cos A = 0$  ;  $\cos B = 9/15$  ;  $\cos C = 4/5$

31. If in a  $\Delta ABC$   $(r_2 - r_1)(r_3 - r_1) = 2r_2r_3$ , then the  $\Delta ABC$  is

- (a) Acute angled (b) obtuse angled  
 (c) equilateral  $\Delta$  (d) right angled  $\Delta$

**Solution:** (d) Given  $(r_2 - r_1)(r_3 - r_1) = 2r_2r_3$

$\Rightarrow \left[ \frac{\Delta}{s-b} - \frac{\Delta}{s-a} \right] \left[ \frac{\Delta}{s-c} - \frac{\Delta}{s-a} \right] = 2 \frac{\Delta}{(s-b)} \cdot \frac{\Delta}{(s-c)}$

$\Rightarrow \left[ \frac{(s-a) - (s-b)}{(s-a)(s-b)} \right] \left[ \frac{(s-a) - (s-c)}{(s-c)(s-a)} \right]$

$= \frac{2}{(s-b)(s-c)}$

$\Rightarrow \left[ \frac{(b-a)(c-a)}{(s-a)^2} \right] = 2$

$\Rightarrow (b-a)(c-a) = 2(s-a)^2 \Rightarrow 2(b-a)(c-a) = [2s-2a]^2$

$\Rightarrow 2(b-a)(c-a) = [b+c-a]^2$

$\Rightarrow 2(bc - ab - ac + a^2) = b^2 + c^2 + a^2 + 2bc - 2ca - 2ab$

$\Rightarrow a^2 = b^2 + c^2$

$\therefore \Delta ABC$  is a rt.  $\Delta$

32. In an equilateral  $\Delta$ , the ratio of inradius, circumradius and one of the exradii is

- (a) 1 : 2 : 4 (b) 2 : 3 : 4  
 (c) 1 : 2 : 3 (d) None of these

**Solution:** (c) Let  $a$  be the side of equilateral  $\Delta$

Then  $\Delta = \frac{\sqrt{3}}{4} a^2$ ,  $s = \frac{3a}{2}$

$\therefore r = \frac{\Delta}{s} = \frac{\left( \frac{\sqrt{3}}{4} a^2 \right)}{\left( \frac{3}{2} a \right)} = \frac{\sqrt{3}}{4} \times \frac{2}{3} a = \frac{1}{2\sqrt{3}} a$

Also  $R = \frac{abc}{4\Delta} = \frac{a^3}{4 \left( \frac{\sqrt{3}}{4} a^2 \right)} = \frac{a}{\sqrt{3}}$

$r_1 = \frac{\Delta}{s-a} = \frac{\frac{\sqrt{3}}{4} a^2}{a/2} = \frac{\sqrt{3}}{4} \times 2a = \frac{\sqrt{3}}{2} a$

Also  $r_2 = \frac{\Delta}{s-b} = r_3 = \frac{\Delta}{s-c} = \frac{\Delta}{s-a} = \frac{\sqrt{3}}{2} a$

$\therefore r : R : r_1 = r : R : r_2 = r : R : r_3 = \frac{a}{2\sqrt{3}} : \frac{a}{\sqrt{3}} : \frac{\sqrt{3}}{2} a$   
 $= \frac{1}{2} : 1 : \frac{3}{2} = 1 : 2 : 3$

33. If in a  $\Delta ABC$   $a^2 + c^2 = 2013b^2$ , then the value of

$\frac{\cot A + \cot C}{\cot B}$  equals

- (a)  $\frac{1}{2012}$  (b)  $\frac{1}{1006}$   
 (c) 2012 (d) 1006

**Solution:** (b)

$\frac{\cot A + \cot C}{\cot B} = \frac{(\cos A \sin C + \sin A \cos C)}{\sin A \sin C \cos B} \sin B$

$= \frac{\sin(A+C) \sin B}{\sin A \sin C \cos B} = \frac{\sin[\pi - B] \sin B}{\sin A \sin C \cos B}$

$= \frac{\sin^2 B}{\sin A \sin C \cos B}$

$$\begin{aligned}
 &= \frac{b^2}{4R^2 \left(\frac{a}{2R}\right) \left(\frac{c}{2R}\right) \cos B} = \frac{b^2}{ac \cos B} \\
 &= \frac{2b^2}{2ac \cos B} = \frac{2b^2}{a^2 + c^2 - b^2} = \frac{2b^2}{2013b^2 - b^2} \\
 &= \frac{2b^2}{2012b^2} = \frac{1}{1006}
 \end{aligned}$$

34. If P is a point on the altitude AL of  $\triangle ABC$  such that  $\angle PBC = B/3$ , then the relation between Ap (= x) and BP (= y) is

- (a)  $x^2 + y^2 = 2c^2$       (b)  $x^2 + cy = c^2$   
 (c)  $x^2 + cy^2 = c^2$       (d) None of these

**Solution:** (b) In  $\triangle ABP$ , by sine formula,

$$\frac{AP}{\sin \frac{2B}{3}} = \frac{BP}{\sin(90^\circ - B)} = \frac{AB}{\sin(90^\circ + B/3)}$$

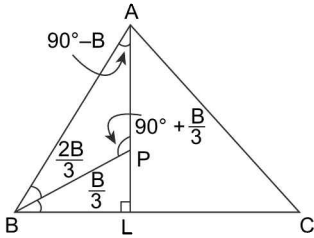

$$\begin{aligned}
 \Rightarrow \frac{AP}{\sin \frac{2B}{3}} &= \frac{BP}{\cos B} = \frac{c}{\cos B/3} \\
 \Rightarrow AP &= \frac{c \sin 2B/3}{\cos B/3}; BP = \frac{c \cos B}{\cos B/3} \\
 \Rightarrow AP &= 2c \sin \frac{B}{3}; BP = c \left[ 4 \cos^2 B/3 - 3 \right] \\
 &= c \left[ 4(1 - \sin^2 B/3) - 3 \right] \\
 &= c \left[ 1 - 4 \sin^2 B/3 \right] = c - \frac{4}{c} c^2 \sin^2 B/3 \\
 &= c - \frac{1}{c} (2c \sin B/3)^2 = c - \frac{1}{c} (AP)^2 \\
 \Rightarrow y &= c - \frac{x^2}{c} \Rightarrow cy = c^2 - x^2 \\
 \Rightarrow x^2 + cy &= c^2
 \end{aligned}$$

35. If in a right angled  $\triangle$  greatest side is 'a', then  $\tan(C/2)$  equals

- (a)  $\frac{a-b}{c}$       (b)  $\frac{a+b}{c}$   
 (c)  $\frac{a \pm b}{c}$  (both possible)      (d) None of these

**Solution:** (a)  $\because$  Greatest side is 'a'

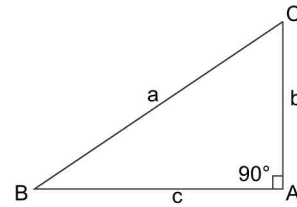

$$\begin{aligned}
 \Rightarrow \angle A &= 90^\circ \\
 \Rightarrow b^2 + c^2 &= a^2 \\
 \therefore \sin C &= c/a \\
 \Rightarrow \frac{2 \tan(C/2)}{1 + \tan^2(C/2)} &= \frac{c}{a} \\
 \Rightarrow 2at &= ct^2 + c; \text{ where } t = \tan C/2 \\
 \Rightarrow ct^2 - 2at + c &= 0
 \end{aligned}$$

$$\begin{aligned}
 \Rightarrow t &= \frac{2a \pm \sqrt{4a^2 - 4c^2}}{2c} \\
 \Rightarrow t &= \frac{2a \pm \sqrt{4(a^2 - c^2)}}{2c} = \frac{2a \pm \sqrt{4b^2}}{2c}
 \end{aligned}$$

$$\Rightarrow t = \frac{a \pm b}{c}$$

$$\therefore \tan C/2 = \frac{a+b}{c} \text{ or } \frac{a-b}{c}$$

$$\text{If } \tan \frac{C}{2} = \frac{a+b}{c} > \frac{c}{c} = 1 \text{ [By } \Delta \text{ inequality]}$$

$$\therefore \tan \frac{C}{2} > 1 \Rightarrow \frac{C}{2} > \frac{\pi}{4} \Rightarrow C > \frac{\pi}{2}$$

which is impossible for right  $\triangle \Delta$

$$\therefore \tan \frac{C}{2} = \frac{a-b}{c}$$

36. In a  $\triangle ABC$ ,  $\sum \sin A = 1 + \sqrt{2}$ ,  $\sum \cos A = \sqrt{2}$ , if the triangle is

- (a) equilateral      (b) right angled  
 (c) isosceles      (d) right angled isosceles  $\triangle$

**Solution:** (d) In an equilateral  $\triangle$ ,  $A = B = C = 60^\circ$

$$\Rightarrow \sum \sin A = \frac{3\sqrt{3}}{2} \neq 1 + \sqrt{2}$$

An equilateral  $\triangle$  is also isosceles  $\triangle$ .

So,  $ABC$  can't be an isosceles  $\triangle$  as it is the example of special isosceles  $\triangle$  which doesnot satisfy the given data.

If  $ABC$  is a right angled with  $\angle A = 90^\circ$ ,  $\angle B = 60^\circ$ ,  $\angle C = 30^\circ$ , then

$$\begin{aligned}
 \sum \sin A &= 1 + \frac{\sqrt{3}}{2} + \frac{1}{2} = \frac{3}{2} + \frac{\sqrt{3}}{2} \\
 &= \frac{1}{2} (3 + \sqrt{3}) \neq 1 + \sqrt{2}
 \end{aligned}$$

**3.60** ➤ Trigonometry

If  $ABC$  is right  $\Delta$  isosceles, then let

$$A = 90^\circ, B = 45^\circ, C = 45^\circ$$

$$\Rightarrow \sum \sin A = 1 + \frac{1}{\sqrt{2}} + \frac{1}{\sqrt{2}} = 1 + \sqrt{2}$$

$$\text{and } \sum \cos A = 0 + \frac{1}{\sqrt{2}} + \frac{1}{\sqrt{2}} = \sqrt{2}$$

$\therefore \Delta ABC$  must be an isosceles right  $\Delta$

**37.** If in a  $\Delta ABC$ ,  $\sum \sin 3A = 0$ , then at least one angle of  $\Delta ABC$  is

- (a)  $60^\circ$                       (b)  $30^\circ$   
 (c)  $90^\circ$                       (d)  $45^\circ$

**Solution:** (a)  $\sum \sin 3A = 0$

$$\Rightarrow \sin 3A + \sin 3B + \sin 3C = 0$$

$$\Rightarrow 2 \sin \left[ \frac{3A+3B}{2} \right] \cos \left[ \frac{3A-3B}{2} \right] +$$

$$2 \sin \frac{3C}{2} \cos \frac{3C}{2} = 0$$

$$\Rightarrow 2 \sin \frac{3}{2}(\pi - C) \cos \frac{3}{2}(A - B) + 2 \sin \frac{3C}{2} \cos \frac{3C}{2} = 0$$

$$\Rightarrow 2 \sin \left[ \frac{3\pi}{2} - \frac{3C}{2} \right] \cos \left( \frac{3A}{2} - \frac{3B}{2} \right) +$$

$$2 \sin \frac{3C}{2} \cos \frac{3C}{2} = 0$$

$$\Rightarrow -2 \cos \frac{3C}{2} \cos \left( \frac{3A}{2} - \frac{3B}{2} \right) + 2 \sin \frac{3C}{2} \cos \frac{3C}{2} = 0$$

$$\Rightarrow 2 \cos \frac{3C}{2} \left[ \sin \frac{3C}{2} - \cos \left( \frac{3A}{2} - \frac{3B}{2} \right) \right] = 0$$

$$\Rightarrow 2 \cos \frac{3C}{2} \left[ \sin 3 \left[ \frac{\pi}{2} - \frac{(A+B)}{2} \right] - \cos \left( \frac{3A}{2} - \frac{3B}{2} \right) \right] = 0$$

$$\Rightarrow 2 \cos \frac{3C}{2} \left[ -\cos \left( \frac{3A}{2} + \frac{3B}{2} \right) - \cos \left( \frac{3A}{2} - \frac{3B}{2} \right) \right] = 0$$

$$\Rightarrow -\cos \frac{3C}{2} \left( 2 \cos \frac{3A}{2} \cos \frac{3B}{2} \right) = 0$$

$$\Rightarrow 4 \cos \frac{3A}{2} \cos \frac{3B}{2} \cos \frac{3C}{2} = 0$$

$$\Rightarrow \cos \frac{3A}{2} \text{ or } \cos \frac{3B}{2} \text{ or } \cos \frac{3C}{2} = 0$$

$$\Rightarrow \frac{3A}{2} = \frac{\pi}{2} \text{ or } \frac{3B}{2} = \frac{\pi}{2} \text{ or } \frac{3C}{2} = \frac{\pi}{2}$$

$$\Rightarrow A = \frac{\pi}{3} \text{ or } B = \frac{\pi}{3} \text{ or } C = \frac{\pi}{3}$$

$\Rightarrow$  At least one angle of  $\Delta ABC$  is  $60^\circ$

**38.** If in a  $\Delta ABC$   $\sum \cos 3A = 1$ , then exactly one angle of  $\Delta$  is

- (a)  $60^\circ$                       (b)  $30^\circ$   
 (c)  $120^\circ$                     (d)  $150^\circ$

**Solution:** (c)  $\sum \cos 3A = 1$

$$\Rightarrow \cos 3A + \cos 3B + \cos 3C = 1$$

$$\Rightarrow 2 \cos \left( \frac{3A+3B}{2} \right) \cos \left( \frac{3A-3B}{2} \right) + \cos 3C = 1$$

$$\Rightarrow 2 \cos \frac{3}{2}[\pi - C] \cos \left( \frac{3A}{2} - \frac{3B}{2} \right) + \cos 3C = 1$$

$$\Rightarrow 2 \cos \left( \frac{3\pi}{2} - \frac{3C}{2} \right) \cos \left( \frac{3A}{2} - \frac{3B}{2} \right) + 1 - 2 \sin^2 \frac{3C}{2} = 1$$

$$\Rightarrow -2 \sin \frac{3C}{2} \cos \left( \frac{3A}{2} - \frac{3B}{2} \right) - 2 \sin^2 \frac{3C}{2} = 0$$

$$\Rightarrow -2 \sin \frac{3C}{2}$$

$$\left[ \cos \left( \frac{3A}{2} - \frac{3B}{2} \right) + \sin \left[ \frac{3\pi}{2} - \left( \frac{3A}{2} + \frac{3B}{2} \right) \right] \right] = 0$$

$$\Rightarrow -2 \sin \frac{3C}{2} \left[ \cos \left( \frac{3A}{2} - \frac{3B}{2} \right) - \cos \left( \frac{3A}{2} + \frac{3B}{2} \right) \right] = 0$$

$$\Rightarrow -2 \sin \frac{3C}{2} \times 2 \sin \frac{3A}{2} \sin \frac{3B}{2} = 0$$

$$\Rightarrow \sin \frac{3A}{2} \sin \frac{3B}{2} \sin \frac{3C}{2} = 0$$

$$\Rightarrow \text{either } \frac{3A}{2} \text{ or } \frac{3B}{2} \text{ or } \frac{3C}{2} = 180^\circ$$

$$\Rightarrow A \text{ or } B \text{ or } C = 120^\circ$$

But exactly one of  $A, B$  and  $C$  can be  $120^\circ$

**39.** In a  $\Delta ABC$ ,  $\angle A = 30^\circ$ ,  $BC = 4$  cm, then the distance of vertex  $A$  from orthocentre is

- (a)  $\frac{\sqrt{3}}{2}$                       (b)  $2\sqrt{3}$   
 (c)  $4\sqrt{3}$                     (d) None of these

**Solution:** (c) We know that the distance of vertex  $A$  from orthocentre is given by  $2R \cos A$

$$= 2R \cos 30^\circ = 2R \left( \frac{\sqrt{3}}{2} \right) = \sqrt{3}R \dots (i)$$

By sine formula

$$\frac{a}{\sin A} = 2R \Rightarrow \frac{4}{\sin 30^\circ} = 2R \Rightarrow \frac{4}{\frac{1}{2}} = R$$

$$\Rightarrow R = 4 \therefore \text{from (i) reqd distance} = 4\sqrt{3}$$

## SECTION-II

### SUBJECTIVE SOLVED EXAMPLES

1. In a triangle  $ABC$ , three circles of radii  $x, y, z$  are drawn touching the sides  $(AB, AC)$ ;  $(BC, BA)$ ;  $(CA, CB)$  and the inscribed circle of the triangle  $ABC$ , then show that,  $r = \sqrt{xy} + \sqrt{yz} + \sqrt{zx}$ ; ( $r$  = radius of incircle of  $\Delta ABC$ .)

$$\text{or } \frac{\sqrt{xyz}}{(\sqrt{x} + \sqrt{y} + \sqrt{z})}$$

**Solution:**  $X_1F = \sqrt{(r+x)^2 - (r-x)^2} = 2\sqrt{xr}$

Similarly,  $Y_1F = 2\sqrt{yr}$  and  $Z_1D = 2\sqrt{zr}$

$$\tan \frac{A}{2} = \frac{r-x}{\sqrt{4xr}} = \frac{\Delta}{s(s-a)}$$

$$\left[ \because \frac{\Delta}{s} = r = (s-a) \tan \frac{A}{2} \right]$$

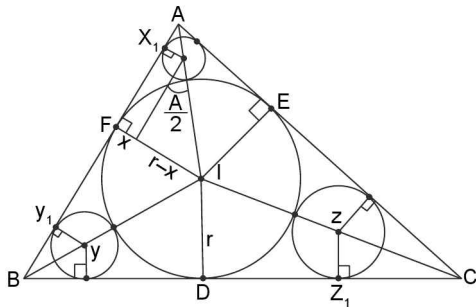

Hence  $\frac{r}{s-a} = \frac{r-x}{\sqrt{4xr}}$

$$\Rightarrow s-a = \frac{2r\sqrt{xr}}{r-x}$$

Similarly,  $s-b = \frac{2r\sqrt{yr}}{r-y}$  and  $s-c = \frac{2r\sqrt{zr}}{r-z}$

But  $r = \frac{\Delta}{s} = \frac{\sqrt{s(s-a)(s-b)(s-c)}}{s}$ .

Hence  $r^2 s = (s-a)(s-b)(s-c)$

$$r^2 [(s-a) + (s-b) + (s-c)] = (s-a)(s-b)(s-c)$$

Substituting the values of  $(s-a)$ ,  $(s-b)$  and  $(s-c)$  and simplifying

$$r^2 (\sqrt{x} + \sqrt{y} + \sqrt{z}) -$$

$$r \left[ \sqrt{xyz} + (\sqrt{xy} + \sqrt{yz} + \sqrt{zx})(\sqrt{x} + \sqrt{y} + \sqrt{z}) \right] + \sqrt{xyz} (\sqrt{xy} + \sqrt{yz} + \sqrt{zx}) = 0$$

which factor out as,  $((\sqrt{x} + \sqrt{y} + \sqrt{z})r - \sqrt{xyz})$

$$(r - (\sqrt{xy} + \sqrt{yz} + \sqrt{zx})) = 0$$

$$\Rightarrow r = \sqrt{xy} + \sqrt{yz} + \sqrt{zx} \text{ or } r = \frac{\sqrt{xyz}}{\sqrt{x} + \sqrt{y} + \sqrt{z}}$$

2. A man standing on the straight sea shore observes two boats in the same direction, the line through them making an angle  $\alpha$  with the shore. He then walks along the shore a distance 'a' where he finds the boats subtend an angle  $\alpha$  at his eye; and on walking a further distance 'b' he finds that they again subtend an angle  $\alpha$  at his eye. Show that the distance between the boats is

$$\left(a + \frac{b}{2}\right) \sec \alpha - 2a \left(\frac{a+b}{2a+b}\right) \cos \alpha. \text{ Neglect the}$$

height of the man's eye above the sea.

**Solution:** Let  $\angle OPA = \theta$ ;  $\angle PAQ = \alpha$  (given)

$\Rightarrow \angle QAB = \theta$ , Draw QM perpendicular AB, clearly APQB is cyclic quadrilateral

Note that QAB is an isosceles  $\Delta$ ;

$$OQ = \left(a + \frac{b}{2}\right) \sec \alpha$$

Now  $PQ = OQ - OP$

$$\therefore PQ = \left(a + \frac{b}{2}\right) \sec \alpha - OP$$

Also  $OP \cdot OQ = OA \cdot OB$  (By theorem of circle)

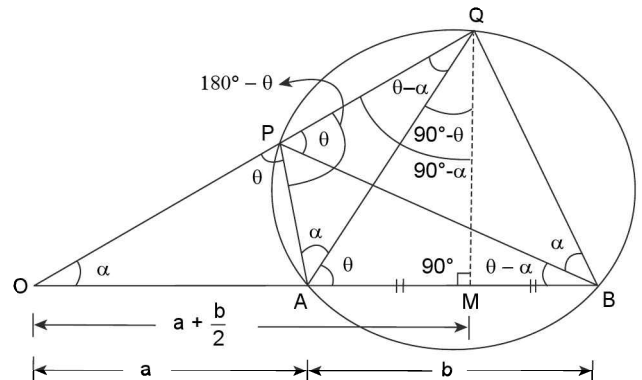

3.62 > Trigonometry

$$\Rightarrow OP = \frac{OA \cdot OB}{OQ}$$

$$\Rightarrow OP = \frac{2a \cdot (a+b) \cos \alpha}{(2a+b)}$$

$$\Rightarrow PQ = \left(a + \frac{b}{2}\right) \sec \alpha - \frac{2a(a+b)}{2a+b} \cos \alpha.$$

3. A church tower stands on the bank of a river which is  $p$  metres wide and on the top of the tower a spire  $q$  metres high. To an observer on opposite bank of the river, the spire subtends the same angle that a pole of  $\frac{p}{q}$  metres high subtends when placed upright on the ground at the foot of the tower. Show that the height of the tower is the root of the equation,  $x^2 + qx + p^2 - pq^2 = 0$ . Neglect the height of the observer.

**Solution:**  $\tan \theta = \frac{p}{q} \cdot \frac{1}{p} = \frac{1}{q}$

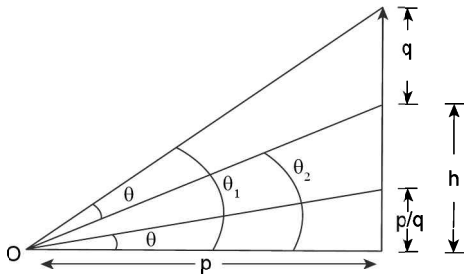

Also  $\theta = \theta_1 - \theta_2 \Rightarrow \tan \theta = \frac{\frac{h+q}{p} - \frac{h}{p}}{1 + \frac{h+q}{p} \cdot \frac{h}{p}}$

$$\frac{1}{q} = \frac{qp}{p^2 + h(h+q)} \Rightarrow h^2 + qh + p^2 - pq^2 = 0$$

$\Rightarrow h$  is a root of quadratic equation  $x^2 + qx + p^2 - pq^2 = 0$

4. If in a  $\Delta ABC$ ,  $\tan A + \tan B + \tan C > 0$ , then show that the triangle is an acute angled triangle.

**Solution:** As  $\tan A + \tan B + \tan C > 0$

$$\Rightarrow \tan A \cdot \tan B \cdot \tan C > 0$$

$$[\because \text{in } \Delta \tan A + \tan B + \tan C = \tan A \cdot \tan B \cdot \tan C]$$

which is possible when two of the angle is obtuse or all are acute.

Two angles can't be obtuse

$\therefore$  all the angles of triangle must be acute.

5. In right triangle  $ABC$ ,  $D$  is the mid-point of hypotenuse  $AB$  and  $E$  is the mid-point of  $AC$ . segments  $BE$  and  $CD$  intersect at  $F$ . If  $AC = \sqrt{2}$  and  $BC = 1$ , then find  $\cos \angle BFC$ .

**Solution:** Slope of  $CD = \frac{\frac{1}{2}}{\frac{1}{\sqrt{2}}} = \frac{1}{\sqrt{2}}$

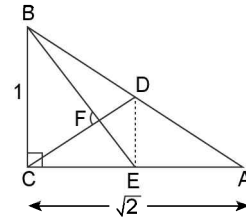

Slope of  $BE = -\sqrt{2} \Rightarrow CD \perp BE$

$$\Rightarrow \angle BFC = 90^\circ \Rightarrow \cos \angle BFC = 0.$$

6. Rectangle I is inscribed in rectangle II so that each side of rectangle II contains one and only vertex of rectangle I. If the dimensions of rectangle I are 1 and 2 and the area of rectangle II is  $\frac{22}{5}$ , then find the perimeter of rectangle II.

**Solution:** Area of rectangle

$$II = (\cos \theta + 2 \sin \theta)(\sin \theta + 2 \cos \theta)$$

$$= \cos \theta \sin \theta + 2 \sin^2 \theta + 2 \cos^2 \theta + 4 \sin \theta \cos \theta$$

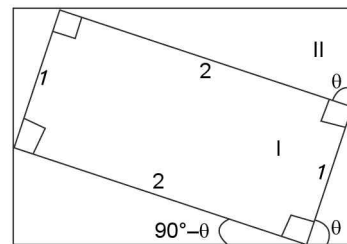

$$\Rightarrow 2 + 5 \sin \theta \cos \theta = \frac{22}{5}$$

$$\Rightarrow 5 \sin \theta \cos \theta = \frac{22}{5} - 2 = \frac{12}{5}$$

$$\Rightarrow 5 \sin \theta \cos \theta = \frac{12}{5}$$

Perimeter of II and rectangle =  $6(\sin \theta + \cos \theta)$

$$= 6\sqrt{1 + 2 \sin \theta \cos \theta} = 6\sqrt{1 + \frac{24}{25}} = 6 \times \frac{7}{5} = \frac{42}{5}$$

7.  $M$  is the mid-point of side  $AB$  of an equilateral triangle  $ABC$ .  $P$  is a point on  $BC$  such that  $AP + PM$  is minimum. If  $AB = 20$ , then evaluate  $AP + PM$ .

**Solution:** Reflect triangle  $ABC$  in  $BC$ .

Then  $PM = PM'$

$AP + PM = AP + PM' = AM'$  which is minimum if  $APM'$  is a straight line and equal to  $AM'$

In  $\triangle AM'C, \cos 120^\circ = \frac{AC^2 + CM'^2 - AM'^2}{2AC \cdot CM'}$

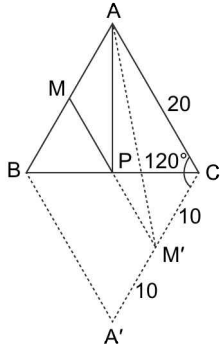

$$\Rightarrow -\frac{1}{2} = \frac{400 + 100 - AM'^2}{2 \cdot 20 \cdot 10}$$

$$\Rightarrow AM' = 500 + 200 \Rightarrow AM' = 10\sqrt{7}$$

8. If  $a, b, c$  are the sides of a triangle such that  $b \cdot c = \lambda^2$ , for some positive  $\lambda$ , then show that  $a \geq 2\lambda \sin \frac{A}{2}$ .

**Solution:** A.M.  $\geq$  G.M.

$$\frac{b+c}{2} \geq \sqrt{bc} = \sqrt{\lambda^2} = |\lambda| = \lambda (\because \lambda > 0) \quad \dots(i)$$

$$\text{and } \frac{a}{\sin A} = \frac{b}{\sin B} = \frac{c}{\sin C} = \frac{b+c}{\sin B + \sin C}$$

$$\Rightarrow \frac{a}{2 \sin \frac{A}{2} \cos \frac{A}{2}} = \frac{b+c}{2 \sin \left(\frac{B+C}{2}\right) \cos \left(\frac{B-C}{2}\right)}$$

$$\Rightarrow a = \frac{(b+c) \sin A/2}{\cos \left(\frac{B-C}{2}\right)} \quad \dots(ii)$$

$\cos \left(\frac{B-C}{2}\right)$  is always positive and  $\frac{1}{\cos \left(\frac{B-C}{2}\right)} \geq 1$

$\therefore$  from (i) and (ii)  $a \geq 2\lambda \sin \frac{A}{2}$ .

9. In a triangle  $ABC$ ,  $B > C$  and both  $B$  and  $C$  satisfy the equation  $3 \tan x - \tan^3 x = k \sec^3 x$ ,  $0 < k < 1$ , then find  $\angle A$ .

**Solution:**  $3 \tan x - \tan^3 x = k \sec^3 x$

$$\Rightarrow 3 \sin x \cos^2 x - \sin^3 x = k \Rightarrow \sin 3x = k$$

$$\Rightarrow \sin 3B = k \text{ and } \sin 3C = k$$

$$\Rightarrow \sin 3B - \sin 3C = 0$$

$$\Rightarrow 2 \cos \frac{3(B+C)}{2} \cdot \sin \frac{3(B-C)}{2} = 0$$

$$\Rightarrow \frac{3(B+C)}{2} = \frac{\pi}{2} \quad \left( \begin{array}{l} \because B > C \Rightarrow B-C \neq 0 \\ \Rightarrow \sin 3 \frac{(B-C)}{2} \neq 0 \end{array} \right)$$

$$\Rightarrow B + C = \frac{\pi}{3} \Rightarrow A = \frac{2\pi}{3}$$

10. Tangents at  $P, Q, R$  on a circle of radius  $r$  form a triangle whose sides are  $3r, 4r, 5r$ , then find  $PR^2 + RQ^2 + QP^2$ .

**Solution:**

$$\text{In } \triangle ARQ = \frac{RQ}{\sin A} = 2AI = \frac{2r}{\sin \left(\frac{A}{2}\right)}; RQ = 4r \cos \left(\frac{A}{2}\right)$$

Similarly,  $RP = 4r \cos \left(\frac{B}{2}\right), PQ = 4r \cos \left(\frac{C}{2}\right)$

$$\therefore PR^2 + RQ^2 + QP^2$$

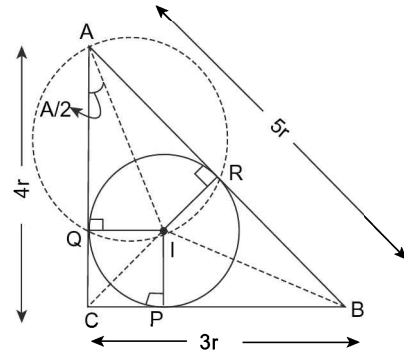

$$= 16r^2 \left[ \cos^2 \left(\frac{A}{2}\right) + \cos^2 \left(\frac{B}{2}\right) + \cos^2 \left(\frac{C}{2}\right) \right]$$

$$= 16r^2 \left[ \frac{1 + \cos A}{2} + \frac{1 + \cos B}{2} + \frac{1}{2} \right]$$

$$= 8r^2 \left[ 3 + \frac{3}{5} + \frac{4}{5} \right] = 8r^2 \left[ \frac{15+7}{5} \right] = \frac{176r^2}{5}$$

11. In a triangle  $ABC$ ;  $\cos A + \cos B + \cos C = \frac{7}{4}$ , then evaluate  $\frac{R}{r}$ .

**Solution:**  $\cos A + \cos B + \cos C = \frac{7}{4}$

$$\Rightarrow 1 + 4 \sin \frac{A}{2} \sin \frac{B}{2} \sin \frac{C}{2} = \frac{7}{4}$$

$$\Rightarrow 4 \sin \frac{A}{2} \sin \frac{B}{2} \sin \frac{C}{2} = \frac{3}{4} \Rightarrow \frac{R}{r} = \frac{3}{4}$$



3.64 > Trigonometry

12. In a  $\Delta ABC$  show that  $\cot A/2 + \cot B/2 + \cot C/2 = \Delta/r^2$

**Solution:**

$$\cot \frac{A}{2} + \cot \frac{B}{2} + \cot \frac{C}{2} = \frac{s(s-a)}{\Delta} + \frac{s(s-b)}{\Delta} + \frac{s(s-c)}{\Delta}$$

$$= \frac{s}{\Delta} [3s - (a+b+c)] = \frac{s[3s-2s]}{\Delta} = \frac{s^2}{\Delta}$$

$$\left[ \begin{array}{l} \because r = (s-a) \tan \frac{A}{2} \\ \Rightarrow \frac{\Delta}{s} = (s-a) \tan \frac{A}{2} \end{array} \right]$$

$$\text{also } \frac{s^2}{\Delta} = \frac{\Delta^2}{r^2 \Delta} = \frac{\Delta}{r^2}$$

13. In acute angled triangle  $ABC$ ,  $r + r_1 = r_2 + r_3$ , and  $\angle B > \frac{\pi}{3}$  then show that  $b + 3c < 3a < 3b + 3c$ .

**Solution:**  $r - r_2 = r_3 - r_1$

$$\Rightarrow \frac{1}{s} - \frac{1}{s-b} = \frac{1}{s-c} - \frac{1}{s-a}, \quad \frac{-b}{s(s-b)} = \frac{-a+c}{(s-a)(s-c)}$$

$$\frac{(s-a)(s-c)}{s(s-b)} = \frac{a-c}{b} \quad \left[ \because \tan \frac{B}{2} = \sqrt{\frac{(s-a)(s-c)}{s(s-b)}} \right]$$

$$\tan^2(B/2) = \frac{a-c}{b}$$

$$\text{But } \frac{B}{2} \in \left( \frac{\pi}{6}, \frac{\pi}{4} \right) \Rightarrow \tan^2 \frac{B}{2} \in \left( \frac{1}{3}, 1 \right)$$

$$\Rightarrow \frac{1}{3} < \frac{a-c}{b} < 1$$

$$\Rightarrow b < 3a - 3c < 3b$$

$$\Rightarrow b + 3c < 3a < 3b + 3c$$

14. Let  $ABC$  be an isosceles triangle with base  $BC$ . If ' $r$ ' is the radius of the circle inscribed in the  $\Delta ABC$  and  $\rho$  be the radius of the circle escribed opposite to the angle  $A$ , then find the product  $\rho r$ .

**Solution:**  $r = \frac{\Delta}{s}, \rho = \frac{\Delta}{s-a}$

$$\rho r = \frac{\Delta^2}{s(s-a)} = \frac{s(s-a)(s-b)(s-c)}{s(s-a)}$$

$$= (s-b)(s-c) = (s-b)^2 \quad (\because b=c)$$

$$= \frac{(2s-2b)^2}{4} = \frac{(a+b+c-2b)^2}{4} \quad (\because b=c)$$

$$= \frac{a^2}{4} = \frac{4R^2 \sin^2 A}{4} = R^2 \sin^2 A \quad (\because a = 2R \sin A)$$

Also if  $\angle B = \theta \Rightarrow \angle A = \pi - 2\theta$

$$\rho r = R^2 \sin^2(\pi - 2\theta) = R^2 \sin^2 2\theta = R^2 \sin^2 2B = R^2 \sin^2 2A$$

$$\therefore \rho r = R^2 \sin^2 2A \quad \text{or} \quad R^2 \sin^2 2B$$

15. The sides of a  $\Delta ABC$  satisfy the equation,  $2a^2 + 4b^2 + c^2 = 4ab + 2ac$ , then find  $\angle A$  and  $\angle B$ .

**Solution:** Given expression  $(a-c)^2 + (a-2b)^2 = 0$

$$\Rightarrow a = 2b \text{ and } c = a. \text{ Sides are } 2b, b, 2b$$

$$\Rightarrow \Delta \text{ is isosceles and } \cos B = \frac{7}{8} \text{ and } \cos A = \frac{1}{4}$$

$$\therefore \cos B = \frac{a^2 + c^2 - b^2}{2ac} = \frac{7b^2}{8b^2} = \frac{7}{8} \Rightarrow B = \cos^{-1}(7/8)$$

$$\text{and } \cos A = \frac{b^2 + c^2 - a^2}{2ac} = \frac{1}{4} \Rightarrow A = \cos^{-1}(1/4)$$

16. If in a triangle  $ABC$ ,  $p, q, r$  are the altitudes from the vertices  $A, B, C$  to the opposite sides, then show that

$$(i) \left( \sum p \right) \left( \sum \frac{1}{p} \right) = \left( \sum a \right) \left( \sum \frac{1}{a} \right)$$

$$(ii) \left( \sum p \right) \left( \sum pq \right) (\Pi a) = \left( \sum a \right) \left( \sum ab \right) (\Pi p)$$

$$(iii) \left( \sum \frac{1}{p} \right) \Pi \left( \frac{1}{p} + \frac{1}{q} - \frac{1}{r} \right) \Pi a^2 = 16R^2$$

**Solution:**  $p = \frac{2\Delta}{a}, q = \frac{2\Delta}{b}, r = \frac{2\Delta}{c}$

$$(i) \left( \sum p \right) \left( \sum \frac{1}{p} \right)$$

$$= 2\Delta \left( \frac{1}{a} + \frac{1}{b} + \frac{1}{c} \right) \left( \frac{a+b+c}{2\Delta} \right) = \left( \sum a \right) \left( \sum \frac{1}{a} \right)$$

$$(ii) \left( \sum p \right) \left( \sum pq \right) \Pi a$$

$$= \left( \frac{2\Delta}{a} + \frac{2\Delta}{b} + \frac{2\Delta}{c} \right) \left( \frac{4\Delta^2}{ab} + \frac{4\Delta^2}{bc} + \frac{4\Delta^2}{ca} \right) abc$$

$$= \frac{2\Delta(ab+bc+ca)}{abc} \cdot 4\Delta^2(b+c+a)$$

$$= \frac{8\Delta^3(a+b+c)(ab+bc+ca)}{abc}$$

$$= \left( \frac{2\Delta}{a} \right) \left( \frac{2\Delta}{b} \right) \left( \frac{2\Delta}{c} \right) \times (ab+bc+ca)(a+b+c)$$

$$= \left( \sum a \right) \left( \sum ab \right) (\Pi p)$$

$$(iii) \left( \sum \frac{1}{p} \right) \Pi \left( \frac{1}{p} + \frac{1}{q} - \frac{1}{r} \right) \Pi a^2$$

$$= \left( \frac{a+b+c}{2\Delta} \right) \left( \frac{a+b-c}{2\Delta} \right)$$

$$\left( \frac{a-b+c}{2\Delta} \right) \left( \frac{b+c-a}{2\Delta} \right) a^2 b^2 c^2$$

$$= \frac{s}{\Delta} \cdot \frac{(s-c)}{\Delta} \cdot \frac{(s-b)}{\Delta} \cdot \frac{(s-a)}{\Delta} (abc)^2$$

$$= \left( \frac{abc}{\Delta} \right)^2 = (4R)^2 = 16R^2$$

17. A pole is situated at a point on the boundary of a circular ground. From some point on the boundary the angle of elevation of top of pole is  $30^\circ$ . On moving further 20 ft. along the boundary the angle of elevation of top of pole is again  $30^\circ$ . On moving a further 10 ft, it is found to be  $60^\circ$ . Find the height of pole and radius of circular ground.

**Solution:** Let  $A$  be the point on the boundary of circular ground at which the pole is situated. Let  $AB$  be the diameter of circular ground and let  $P$  and  $Q$  be the points at which the angles of elevations are  $30^\circ$ . Since angles of elevation of top of pole are equal at  $P$  and  $Q$ , they must be situated symmetrically about point  $B$  such that arc  $(PB) = \text{arc}(BQ) = 10$  ft. Let  $R$  be the point at which the angle of elevation is  $60^\circ$  and  $(QR) = 10$  ft. as shown below

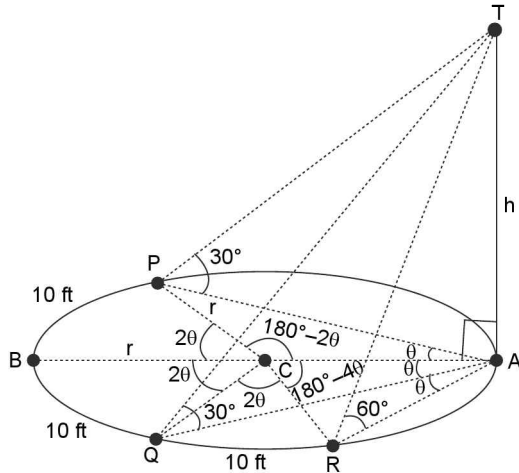

$$\therefore l(\widehat{BP}) = l(\widehat{BQ}) = l(\widehat{QR}) = \theta$$

$$\angle PCB = \angle BCQ = \angle QCR = 2\theta \text{ (say)}$$

$$\text{In rt. } \triangle \Delta APT, AP = h \cot 30^\circ = h\sqrt{3}$$

$$\text{In rt. } \triangle \Delta AQT, AQ = h \cot 30^\circ = h\sqrt{3}$$

$$\text{and } AR = h \cot 60^\circ = h/\sqrt{3}$$

In  $\triangle ACP$ , by sine formula

$$\frac{AP}{\sin(180^\circ - 2\theta)} = \frac{CP}{\sin \theta} \Rightarrow \frac{h\sqrt{3}}{\sin 2\theta} = \frac{r}{\sin \theta}$$

$$\Rightarrow \frac{h\sqrt{3}}{2 \cos \theta} = r \Rightarrow \cos \theta = \frac{\sqrt{3}h}{2r} \dots (i)$$

In  $\triangle ACR$ ,

$$\frac{CR}{\sin 2\theta} = \frac{AR}{\sin(180^\circ - 4\theta)}$$

$$\Rightarrow \frac{r}{\sin 2\theta} = \frac{h/\sqrt{3}}{\sin 4\theta} \Rightarrow \frac{r}{\sin 2\theta} = \frac{h}{\sqrt{3}(2 \sin 2\theta \cos 2\theta)}$$

$$\Rightarrow r = \frac{h}{2\sqrt{3} \cos 2\theta} \Rightarrow \cos 2\theta = \frac{h}{2\sqrt{3}r}$$

$$\Rightarrow 2 \cos^2 \theta - 1 = \frac{h}{2\sqrt{3}r} \Rightarrow 2 \left( \frac{\sqrt{3}h}{2r} \right)^2 - 1 = \frac{h}{2\sqrt{3}r}$$

$$\Rightarrow \frac{2(3h^2)}{4r^2} - 1 = \frac{h}{2\sqrt{3}r} \Rightarrow \frac{3h^2}{2r^2} - \frac{1}{2\sqrt{3}} \frac{h}{r} - 1 = 0$$

$$\Rightarrow \frac{h}{r} = \frac{1}{2\sqrt{3}} \pm \sqrt{\left( \frac{-1}{2\sqrt{3}} \right)^2 - 4 \left( \frac{3}{2} \right) (-1)}$$

$$\Rightarrow \frac{h}{r} = \frac{1}{2\sqrt{3}} \pm \sqrt{\frac{1}{12} + 6}$$

$$\Rightarrow \frac{h}{r} = \frac{1}{2\sqrt{3}} \pm \sqrt{\frac{73}{12}} \Rightarrow \frac{h}{r} = \frac{1}{2\sqrt{3}} \pm \frac{\sqrt{73}}{2\sqrt{3}} = \frac{(1 + \sqrt{73})}{6\sqrt{3}}$$

$\therefore$  From equation (i)

$$\cos \theta = \frac{\sqrt{3}h}{2r} = \frac{\sqrt{3}}{2} \left( \frac{\sqrt{73} + 1}{6\sqrt{3}} \right) = \frac{\sqrt{73} + 1}{12}$$

$$\text{Also } 2\theta = \frac{10}{r} \Rightarrow r = \frac{5}{\theta} = \frac{5}{\cos^{-1} \left( \frac{\sqrt{73} + 1}{12} \right)}$$

$$\text{Also } \frac{h}{r} = \frac{\sqrt{73} + 1}{6\sqrt{3}}$$

$$\Rightarrow h = \frac{(\sqrt{73} + 1)}{6\sqrt{3}} r = \frac{\sqrt{73} + 1}{6\sqrt{3}} \cdot \frac{5}{\cos^{-1} \left( \frac{\sqrt{73} + 1}{12} \right)}$$

$$= \frac{5 \left( \frac{\sqrt{73} + 1}{\sqrt{3}} \right)}{\cos^{-1} \left( \frac{\sqrt{73} + 1}{12} \right)}$$

18. The perimeter of a triangle is 6 times the arithmetic mean of the sines of its angles. If the side  $b$  is 1, then

$$\text{evaluate } \lim_{A \rightarrow C} \frac{\sqrt{1 - 4(2 - \sqrt{3}) \sin A \sin C}}{|A - C|}$$

$$\text{Solution: Given, } a + b + c = 6 \left( \frac{\sin A + \sin B + \sin C}{3} \right)$$

$$\Rightarrow a + b + c = 2(\sin A + \sin B + \sin C) \dots (i)$$

$$\therefore \frac{a}{\sin A} = \frac{b}{\sin B} = \frac{c}{\sin C}$$

$$\Rightarrow a = \frac{\sin A}{\sin B}; c = \frac{\sin C}{\sin B} \quad (\because b = 1)$$

$$\begin{aligned} \therefore \text{ from (i) } \frac{\sin A}{\sin B} + 1 + \frac{\sin C}{\sin B} &= 2(\sin A + \sin B + \sin C) \\ \Rightarrow \sin A + \sin B + \sin C &= 2(\sin A + \sin B + \sin C) \\ & \quad (\sin B) \\ \Rightarrow (\sin A + \sin B + \sin C)(2\sin B - 1) &= 0 \\ \Rightarrow 2\sin B - 1 = 0 \quad [\because \text{ In a } \Delta \sin A, \sin B, \sin C > 0, \\ & \quad \sin A + \sin B + \sin C \neq 0] \\ \Rightarrow \sin B = 1/2 \\ \Rightarrow \cos B = \frac{\sqrt{3}}{2} \\ \therefore \text{ By cosine formula} \\ \cos B &= \frac{a^2 + c^2 - b^2}{2ac} \\ \Rightarrow \frac{\sqrt{3}}{2} &= \frac{a^2 + c^2 - b^2}{2ac} \\ \Rightarrow \sqrt{3} &= \frac{a^2 + c^2 - b^2}{ac} \\ \Rightarrow \sqrt{3}ac &= a^2 + c^2 - b^2 \\ \sqrt{3}ac - 2ac &= a^2 + c^2 - 2ac - b^2 \\ \Rightarrow (\sqrt{3} - 2)ac &= (a - c)^2 - b^2 \\ \Rightarrow (a - c)^2 &= b^2 - (2 - \sqrt{3})ac \\ \Rightarrow (a - c)^2 &= b^2 - (2 - \sqrt{3})ac \\ \Rightarrow |a - c| &= \sqrt{b^2 - (2 - \sqrt{3})ac} \\ \Rightarrow |2R\sin A - 2R\sin C| \\ &= \sqrt{4R^2 \sin^2 B - (2 - \sqrt{3})4R^2 \sin A \sin C} \\ \Rightarrow |\sin A - \sin C| &= \sqrt{\sin^2 B - (2 - \sqrt{3})\sin A \sin C} \\ \Rightarrow \left| 2\cos \frac{A+C}{2} \sin \frac{A-C}{2} \right| &= \sqrt{\frac{1}{4} - (2 - \sqrt{3})\sin A \sin C} \\ \Rightarrow 2\cos \left( \frac{A+C}{2} \right) \left| \sin \left( \frac{A-C}{2} \right) \right| \\ &= \frac{1}{2} \sqrt{1 - 4(2 - \sqrt{3})\sin A \sin C} \\ \Rightarrow \sqrt{1 - 4(2 - \sqrt{3})\sin A \sin C} \\ &= 4\cos \left( \frac{A+C}{2} \right) \left| \sin \left( \frac{A-C}{2} \right) \right| \\ \Rightarrow \sqrt{\frac{1 - 4(2 - \sqrt{3})\sin A \sin C}{|A-C|}} \\ &= \frac{4\cos \left( \frac{A+C}{2} \right) \left| \sin \left( \frac{A-C}{2} \right) \right|}{|A-C|} \end{aligned}$$

$$\begin{aligned} \Rightarrow \lim_{A \rightarrow C} \frac{\sqrt{1 - 4(2 - \sqrt{3})\sin A \sin C}}{|A-C|} \\ = \lim_{A \rightarrow C} 4\cos \left( \frac{A+C}{2} \right) \left| \frac{\sin \left( \frac{A-C}{2} \right)}{2 \left( \frac{A-C}{2} \right)} \right| = 2 \end{aligned}$$

19. If in  $\Delta ABC$ ,  $BC = 6$ ,  $CA = 3$  and  $AB = 4$  and  $D$  and  $E$  trisect  $BC$  and  $\angle CAE = \theta$ , then find  $\tan \theta$ .

**Solution:**

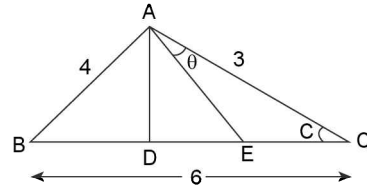

$$\begin{aligned} \because D \text{ and } E \text{ trisect } BC \\ \Rightarrow BD = DE = EC = 6/3 = 2 \\ \text{Now in } \Delta ACE, \text{ by cosine formula} \\ \cos C = \frac{(AC)^2 + (CE)^2 - (AE)^2}{2(AC)(CE)} \\ \Rightarrow \cos C = \frac{9 + 4 - (AE)^2}{2(3)(2)} \\ \Rightarrow \frac{(6)^2 + (3)^2 - (4)^2}{2(6)(3)} = \frac{13 - (AE)^2}{12} \quad [\text{Using cosine} \\ \text{Formula in } \Delta ABC] \\ \Rightarrow \frac{29}{3} = 13 - (AE)^2 \\ \Rightarrow (AE)^2 = 13 - \frac{29}{3} = \frac{10}{3} \Rightarrow AE = \sqrt{\frac{10}{3}} \\ \text{From } \Delta ACE, \text{ by cosine formula} \\ \cos \theta = \frac{(AC)^2 + (AE)^2 - (EC)^2}{2(AC)(AE)} = \frac{9 + \left(\frac{10}{3}\right) - (4)}{2(3)\left(\sqrt{\frac{10}{3}}\right)} \\ \Rightarrow \cos \theta = \frac{\frac{25}{3}}{2\sqrt{30}} = \frac{25}{3} \times \frac{1}{2\sqrt{30}} = \frac{25}{6\sqrt{30}} \\ \Rightarrow \sec \theta = \frac{6\sqrt{30}}{25} \\ \therefore \tan \theta = \sqrt{\sec^2 \theta - 1} = \sqrt{\frac{36 \times 30}{625} - 1} \\ = \sqrt{\frac{1080 - 625}{625}} = \sqrt{\frac{455}{625}} = \sqrt{\frac{91}{125}} \end{aligned}$$

**Assertion/Reasoning Type**

The questions given below consist of an assertion (A) and the reason (R). Use the following key to choose the appropriate answer.

- (a) If both assertion and reason are correct and reason is the correct explanation of the assertion.
- (b) If both assertion and reason are correct but reason is not correct explanation of the assertion.
- (c) If assertion is correct, but reason is incorrect
- (d) If assertion is incorrect, but reason is correct

Now consider the following statements:

**20. A:** In a  $\Delta ABC$ , if  $a < b < c$  and  $r$  is inradius and  $r_1, r_2, r_3$  are the exradii opposite to angle  $A, B, C$  respectively, then  $r < r_1 < r_2 < r_3$

**R:** For,  $\Delta ABC$   $r_1 r_2 + r_2 r_3 + r_3 r_1 = \frac{r_1 r_2 r_3}{r}$

**Solution: (b) A:**  $a < b < c$

$$\Rightarrow s > s - a > s - b > s - c$$

$$\Rightarrow \frac{\Delta}{s} < \frac{\Delta}{s-a} < \frac{\Delta}{s-b} < \frac{\Delta}{s-c}$$

$$\Rightarrow r < r_1 < r_2 < r_3$$

**R:**  $r_1 = \frac{\Delta}{s-a}, r_2 = \frac{\Delta}{s-b}, r_3 = \frac{\Delta}{s-c}, r = \frac{\Delta}{s}$

$$\frac{1}{r_1} + \frac{1}{r_2} + \frac{1}{r_3} = \frac{s}{\Delta} = \frac{1}{r} \Rightarrow r_1 r_2 + r_2 r_3 + r_3 r_1 = \frac{r_1 r_2 r_3}{r}$$

$\therefore$  Assertion/Reason both are correct but Reason is not the correct explanation of Assertion.

**21. Match the following type:**

**Column-I**

(i) In a  $\Delta ABC$   $(a + b + c)(b + c - a) = \lambda bc$ , where  $\lambda \in \mathbb{Z}$ , then greatest value of  $\lambda$  is

(ii) In a  $\Delta ABC$ ,  $\tan A + \tan B + \tan C = 9$ . If  $\tan^2 A + \tan^2 B + \tan^2 C = k$ , then least value of  $k$  satisfying is

(iii) In a triangle  $ABC$ , the line joining the circumcentre to the incentre is parallel to  $BC$ , then value of  $\cos B + \cos C$  is

(iv) If in a  $\Delta ABC$ ,  $a = 5, b = 4$  and  $\cos(A - B) = \frac{31}{32}$ ,

then the third side  $c$  is equal to

**Column-II**

(a) 3

(b)  $3(9)^{2/3}$

(c) 1

(d) 6

**Ans.** (i)  $\rightarrow$  (a), (ii)  $\rightarrow$  (b), (iii)  $\rightarrow$  (c), (iv)  $\rightarrow$  (d)

**Solution:** (i)  $(b + c)^2 - a^2 = \lambda bc$

$$\text{or } b^2 + c^2 - a^2 = (\lambda - 2)bc$$

$$\frac{b^2 + c^2 - a^2}{2bc} = \frac{\lambda - 2}{2}$$

$$\cos A = \frac{\lambda - 2}{2} < 1$$

$$\text{or } \lambda - 2 < 2$$

$$\lambda < 4 \Rightarrow \text{Greatest integer value of } \lambda = 3$$

(ii)  $\tan A + \tan B + \tan C = 9$  (given) in any triangle,  
 $\tan A + \tan B + \tan C = \tan A \tan B \tan C$

$$\text{and } \frac{\tan^2 A + \tan^2 B + \tan^2 C}{3} \geq (\tan A \tan B \tan C)^{2/3}$$

(by AM  $\geq$  GM)

$$k \geq 3(9)^{2/3}$$

$$k \geq 9 \cdot (3)^{1/3}$$

(iii) since the line joining the circumcentre to the incentre is parallel to  $BC$

$$\therefore r = R \cos A$$

$$\therefore 4R \sin \frac{A}{2} \sin \frac{B}{2} \sin \frac{C}{2} = R \cos A$$

$$\therefore -1 + \cos A + \cos B + \cos C = \cos A$$

$$\therefore \cos B + \cos C = 1$$

(iv)  $a = 5, b = 4$

$$\cos(A - B) = \frac{31}{32}$$

$$\tan \frac{A - B}{2} = \frac{a - b}{a + b} \cot \frac{C}{2} = \frac{1}{9} \cot \frac{C}{2}$$

$$\Rightarrow \cos(A - B) = \frac{1 - \tan^2 \frac{A - B}{2}}{1 + \tan^2 \frac{A - B}{2}}$$

$$\Rightarrow \frac{31}{32} = \frac{1 - \frac{1}{81} \cot^2 \frac{C}{2}}{1 + \frac{1}{81} \cot^2 \frac{C}{2}}$$

$$\Rightarrow 31 + \frac{31}{81} \cot^2 \frac{C}{2} = 32 - \frac{32}{81} \cot^2 \frac{C}{2} \Rightarrow \frac{7}{9} \cot^2 \frac{C}{2} = 1$$

$$\Rightarrow \cos C = \frac{1 - \tan^2 \frac{C}{2}}{1 + \tan^2 \frac{C}{2}} = \frac{1 - \frac{7}{9}}{1 + \frac{7}{9}} = \frac{2}{16} = \frac{1}{8}$$

$$\Rightarrow \cos C = \frac{a^2 + b^2 - c^2}{2ab} \Rightarrow \frac{25 + 16 - c^2}{2 \times 20} = \frac{1}{8}$$

$$\Rightarrow 25 + 16 - c^2 = 5$$

$$\Rightarrow c^2 = 36$$

$$\Rightarrow c = 6$$

22. Match the following type:

Column-I

- (i) In a  $\Delta ABC$  if  $\cos A + \cos B + \cos C = \frac{5}{3}$ , then  $\frac{3r}{R}$  equals
- (ii) If a chord of length unity subtends an angle  $\theta$  at the circumference of a circle whose radius is  $R$ , then  $4R \sin \theta$  equals
- (iii) In a  $\Delta ABC$ , if  $r = \frac{1}{3}$  and  $\alpha, \beta, \gamma$  are lengths of altitudes of a  $\Delta ABC$ , then  $\frac{1}{\alpha} + \frac{1}{\beta} + \frac{1}{\gamma}$  equals
- (iv) Incircle of radius 4 cm of a triangle  $ABC$  touches the side  $BC$  at  $D$ . If  $BD = 6, DC = 8$  and  $\Delta$  be the area of triangle, then  $\sqrt{\Delta - 3}$  equals

Column-II

- (a) 5
- (b) 3
- (c) 2
- (d) 4

Ans. (i)  $\rightarrow$  (c), (ii)  $\rightarrow$  (c), (iii)  $\rightarrow$  (b), (iv)  $\rightarrow$  (b)

**Solution:** (i)  $\cos A + \cos B + \cos C = \frac{5}{3}$   
 we know that  $\cos A + \cos B + \cos C = 1 + 4 \sin \frac{A}{2} \sin \frac{B}{2} \sin \frac{C}{2} = 1 + \frac{r}{R}$   
 $\therefore \frac{5}{3} = 1 + \frac{r}{R} \Rightarrow \frac{r}{R} = \frac{2}{3} \Rightarrow \frac{3r}{R} = 2$

(ii) In triangle  $AMC$

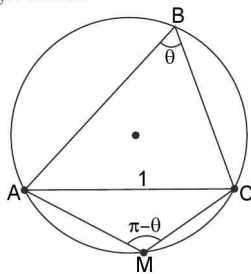

$$\sin(\pi - \theta) = \frac{1}{2R} \text{ (By sine formula)}$$

$$\therefore R \sin \theta = \frac{1}{2}$$

$$\Rightarrow 4R \sin \theta = 2$$

$$(iii) \alpha = \frac{2\Delta}{a} \therefore \frac{1}{\alpha} = \frac{a}{2\Delta}$$

$$\therefore \sum \frac{1}{\alpha} = \sum \frac{a}{2\Delta} = \frac{s}{\Delta} = \frac{1}{r} = 3$$

(iv)

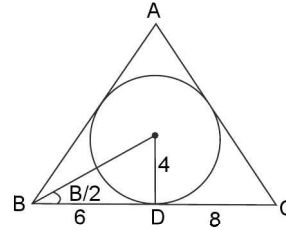

$$\tan \frac{B}{2} = \frac{4}{6} = \frac{2}{3}, \tan \frac{C}{2} = \frac{1}{2}$$

$$\tan \left( \frac{A}{2} \right) = \tan \left( \frac{\pi}{2} - \left( \frac{B}{2} + \frac{C}{2} \right) \right) = \cot \left( \frac{B}{2} + \frac{C}{2} \right)$$

$$\tan \left( \frac{A}{2} \right) = \frac{1 - \tan \frac{B}{2} \cdot \tan \frac{C}{2}}{\tan \left( \frac{B}{2} \right) + \tan \left( \frac{C}{2} \right)}$$

$$\Rightarrow \frac{r}{s-a} = \frac{1 - \frac{2}{3} \times \frac{1}{2}}{\frac{2}{3} + \frac{1}{2}} = \frac{4}{7} \Rightarrow \frac{4}{s-a} = \frac{4}{7}$$

$$\Rightarrow s-a = 7; a = 14$$

$$\Rightarrow s = 21$$

$$\therefore \Delta = rs = 84 \Rightarrow \sqrt{\Delta - 3} = 3$$

23. Column-I

- (i) If  $a, b, c$  are in A.P., then
- (ii) If  $a^2, b^2, c^2$  are in A.P., then
- (iii) If  $a, b, c$  are in H.P., then

Column II

(a)  $\sin^2 \frac{A}{2}, \sin^2 \frac{B}{2}, \sin^2 \frac{C}{2}$  are in H.P.

(b)  $\cot \frac{A}{2}, \cot \frac{B}{2}, \cot \frac{C}{2}$  are in A.P.

(c)  $\cot A, \cot B, \cot C$  are in A.P.

Ans. (i)  $\rightarrow$  (b); (ii)  $\rightarrow$  (c); (iii)  $\rightarrow$  (a).

**Solution:** (ii)  $a, b, c$  are in A.P.

$$\Rightarrow b - a = c - b \Rightarrow \sin B - \sin A = \sin C - \sin B$$

$$\Rightarrow 2 \cos \frac{B+A}{2} \sin \frac{B-A}{2} = 2 \cos \frac{C+B}{2} \sin \frac{C-B}{2}$$

$$\Rightarrow 2 \sin \frac{C}{2} \sin \frac{B-A}{2} = 2 \sin \frac{A}{2} \sin \frac{C-B}{2}$$

$$\Rightarrow \sin \frac{C}{2} \left( \sin \frac{B}{2} \cos \frac{A}{2} - \cos \frac{B}{2} \sin \frac{A}{2} \right) =$$

$$\sin \frac{A}{2} \left( \sin \frac{C}{2} \cos \frac{B}{2} - \cos \frac{C}{2} \sin \frac{B}{2} \right)$$

$$\Rightarrow \cot \frac{A}{2} - \cot \frac{B}{2} = \cot \frac{B}{2} - \cot \frac{C}{2}$$

$$\Rightarrow \cot \frac{A}{2}, \cot \frac{B}{2}, \cot \frac{C}{2} \text{ are in A.P.}$$

(ii)  $a^2, b^2, c^2$  are in A.P.  
 $\Rightarrow -2a^2, -2b^2, -2c^2$  are in A.P.  
 $\Rightarrow b^2 + c^2 - a^2, c^2 + a^2 - b^2, a^2 + b^2 - c^2$  are in A.P.  
 (adding  $a^2 + b^2 + c^2$  to each term).

$\Rightarrow 2bc \cos A, 2ca \cos B, 2ab \cos C$  are in A.P.  
 $\Rightarrow \cot A, \cot B, \cot C$  are in A.P.  
 (dividing throughout by  $4\Delta = 2bc \sin A$  etc.)

(iii)  $a, b, c$  are in H.P.  
 $\Rightarrow \frac{1}{a}, \frac{1}{b}, \frac{1}{c}$  are in A.P.  $\Rightarrow \frac{s}{a}, \frac{s}{b}, \frac{s}{c}$  are in A.P.

$\Rightarrow \frac{s-a}{a}, \frac{s-b}{b}, \frac{s-c}{c}$  are in A.P.  
 (subtracting 1 from each)

$$\Rightarrow \frac{bc}{(s-b)(s-c)}, \frac{ca}{(s-c)(s-a)}, \frac{ab}{(s-a)(s-b)}$$

are in A.P. (multiplying each by  $\frac{abc}{(s-a)(s-b)(s-c)}$ )

$\Rightarrow \frac{1}{\sin^2 \frac{A}{2}}, \frac{1}{\sin^2 \frac{B}{2}}, \frac{1}{\sin^2 \frac{C}{2}}$  are in A.P.

$\therefore \sin^2 \left(\frac{A}{2}\right), \sin^2 \left(\frac{B}{2}\right), \sin^2 \left(\frac{C}{2}\right)$  are in H.P.

**Comprehension Type**

**A:** Let us consider a triangle  $ABC$  with lengths of sides  $a, b, c$  and angles opposite to sides  $a, b, c$  be  $A, B, C$  respectively. cosine of angles is given by  $\cos A = \frac{b^2 + c^2 - a^2}{2bc}$ ,  $\cos B = \frac{a^2 + c^2 - b^2}{2ac}$ ,  $\cos C = \frac{a^2 + b^2 - c^2}{2ab}$ .

24. If  $a = 2, b = \sqrt{6}, c = \sqrt{3} - 1$ , then  $\tan C =$
- (a)  $\sqrt{3}$  (b)  $\frac{1}{\sqrt{3}}$   
 (c)  $\sqrt{2} - 1$  (d)  $2 - \sqrt{3}$

**Solution: (d)**

$$\cos C = \frac{a^2 + b^2 - c^2}{2ab} = \frac{(2)^2 + (\sqrt{6})^2 - (\sqrt{3} - 1)^2}{2 \cdot 2 \cdot \sqrt{6}}$$

$$\Rightarrow \cos C = \frac{\sqrt{3} + 1}{2\sqrt{2}} \Rightarrow C = 15^\circ$$

$$\Rightarrow \tan C = \tan 15^\circ = 2 - \sqrt{3}$$

25. If  $a : b : c = 7 : 8 : 9$ , then  $\cos A : \cos B : \cos C =$
- (a)  $7 : 9 : 11$  (b)  $14 : 11 : 6$   
 (c)  $7 : 19 : 25$  (d)  $8 : 6 : 5$

**Solution:** (b)  $a : b : c = 7 : 8 : 9$   
 $\Rightarrow a = 7k, b = 8k, c = 9k$

$$\Rightarrow \cos A = \frac{(8k)^2 + (9k)^2 - (7k)^2}{2(8k)(9k)} = \frac{2}{3}$$

$$\Rightarrow \cos B = \frac{(7k)^2 + (9k)^2 - (8k)^2}{2(7k)(9k)} = \frac{11}{21}$$

$$\Rightarrow \cos C = \frac{(7k)^2 + (8k)^2 - (9k)^2}{2(7k)(8k)} = \frac{2}{7}$$

$$\Rightarrow \cos A : \cos B : \cos C = \frac{2}{3} : \frac{11}{21} : \frac{2}{7} = 14 : 11 : 6$$

**B:** Consider a triangle  $ABC$ , where  $x, y, z$  are the length of perpendicular drawn from the vertices of the triangle to the opposite sides  $a, b, c$  respectively. Let the letters  $R, r, s, \Delta$  denote the circumradius, inradius, semiperimeter and area of the triangle respectively.

26. If  $\frac{bx}{c} + \frac{cy}{a} + \frac{az}{b} = \frac{a^2 + b^2 + c^2}{k}$ , then the value of  $k$  is

- (a)  $R$  (b)  $S$   
 (c)  $2R$  (d)  $3/2R$

**Solution: (c)**

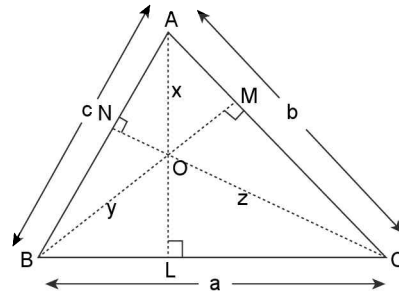

Clearly,  $2\Delta = ax = by = cz$ ,

$$\therefore \frac{b^2 xa + c^2 yb + a^2 zc}{abc} = \frac{a^2 + b^2 + c^2}{k}$$

$$\Rightarrow \frac{b^2(2\Delta) + c^2(2\Delta) + a^2(2\Delta)}{abc} = \frac{a^2 + b^2 + c^2}{k}$$

3.70 > Trigonometry

$$\Rightarrow \frac{2\Delta}{abc} = \frac{1}{k} \Rightarrow k = \frac{abc}{2\Delta} = 2R$$

$$\Rightarrow \left[ \because \Delta = \frac{abc}{4R} \right]$$

27. If  $\cot A + \cot B + \cot C = k \left( \frac{1}{x^2} + \frac{1}{y^2} + \frac{1}{z^2} \right)$ , then the value of  $k$  is

- (a)  $R^2$  (b)  $rR$   
 (c)  $\Delta$  (d)  $a^2 + b^2 + c^2$

**Solution:** (c)

$$\frac{1}{x^2} + \frac{1}{y^2} + \frac{1}{z^2} = \frac{a^2}{4\Delta^2} + \frac{b^2}{4\Delta^2} + \frac{c^2}{4\Delta^2} = \frac{a^2 + b^2 + c^2}{4\Delta^2}$$

$$\text{and } \cot A + \cot B + \cot C = \frac{R}{abc}$$

$$(b^2 + c^2 - a^2 + c^2 + a^2 - b^2 + a^2 + b^2 - c^2)$$

$$= \frac{R}{abc} (b^2 + c^2 + a^2) = \frac{R}{abc} \left( \frac{4\Delta^2}{x^2} + \frac{4\Delta^2}{y^2} + \frac{4\Delta^2}{z^2} \right)$$

$$= \frac{4\Delta^2 R}{abc} \left( \frac{1}{x^2} + \frac{1}{y^2} + \frac{1}{z^2} \right)$$

$$= \frac{4\Delta R}{abc} \cdot \Delta \left( \frac{1}{x^2} + \frac{1}{y^2} + \frac{1}{z^2} \right) = \Delta \left( \frac{1}{x^2} + \frac{1}{y^2} + \frac{1}{z^2} \right)$$

$$\therefore k = \Delta$$

28. The value of

$$\frac{c \sin B + b \sin C}{x} + \frac{a \sin C + c \sin A}{y} + \frac{b \sin A + a \sin B}{z}$$

is equal to

- (a)  $\frac{R}{r}$  (b)  $\frac{S}{R}$   
 (c) 2 (d) 6

$$\text{Solution: (d) } \sum \frac{c \sin B + b \sin C}{x}, \sum \frac{x+x}{x} = 6$$

**C:**  $AP, BQ, CR$  are the diameters of the circumcircle of a  $\Delta ABC$ . Let  $\Delta_1, \Delta_2, \Delta_3, \Delta$  be the areas of  $\Delta BPC, \Delta CQA, \Delta ARB$  and  $\Delta ABC$  respectively, then

29.  $\Delta_1 =$

- (a)  $2R^2 \cos B \cos C \sin A$   
 (b)  $R^2 \sin B \sin C \cos A$   
 (c)  $R^2 \cos B \cos C \sin A$   
 (d)  $2R^2 \sin B \sin C \cos A$

**Solution:** (a)  $AP = 2R,$

$$BP^2 = AP^2 - AB^2 = 4R^2 - c^2$$

$$= 4R^2 - 4R^2 \sin^2 C = 4R^2 \cos^2 C$$

Similarly,  $CP^2 = 4R^2 - b^2 = 4R^2 \cos^2 B$

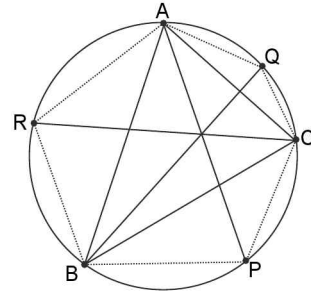

$$\therefore \Delta_1^2 = \frac{1}{4} \cdot BP^2 \cdot PC^2 \sin^2 A = \frac{1}{4}$$

$$(4R^2 \cos^2 C \cdot 4R^2 \cos^2 B) \sin^2 A$$

$$(\because BPC = \pi - A) = 4R^4 \cos^2 B \cos^2 C \sin^2 A$$

$$\therefore \Delta_1 = 2R^2 \cos B \cos C \sin A \text{ numerically.}$$

30.  $\Delta_1 + \Delta_2 + \Delta_3 =$

- (a)  $\Delta$  (b)  $2\Delta$   
 (c)  $\frac{\Delta}{2}$  (d)  $4\Delta$

**Solution:** (a)  $\Delta_1 + \Delta_2 + \Delta_3 = 2R^2 (\cos B \cos C \sin A + \cos C \cos A \sin B + \cos A \cos B \sin C)$   
 $= 2R^2 \{ \cos B \sin(A+C) + \cos C \cos A \sin B \}$   
 $= 2R^2 \{ \cos B \sin B + \cos C \cos A \sin B \}$   
 $= R^2 \sin B \{ 2 \cos B + \cos(A+C) + \cos(A-C) \}$   
 $= R^2 \sin B \{ \cos B + \cos(A-C) + (\cos(A+C) + \cos B) \}$   
 $= 2R^2 \sin A \sin B \sin C = \Delta$

31.  $BP^2 + CQ^2 + AR^2 =$

- (a)  $4R^2 [1 - 2 \cos A \cos B \cos C]$   
 (b)  $4R^2 [1 + 2 \cos A \cos B \cos C]$   
 (c)  $8R^2 \cos A \cos B \cos C$   
 (d)  $4R^2 [1 + 2 \sin A \sin B \sin C]$

**Solution:** (a)  $BP^2 = 4R^2 \cos^2 C$  (already proved).

Similarly,  $CQ^2 = 4R^2 \cos^2 A$  and

$$AR^2 = 4R^2 \cos^2 B$$

$$\therefore BP^2 + CQ^2 + AR^2 = 4R^2 (\cos^2 A + \cos^2 B + \cos^2 C)$$

$$= 4R^2 \left\{ \frac{3}{2} + \frac{1}{2} (\cos 2A + \cos 2B + \cos 2C) \right\}$$

$$= 4R^2 \left\{ \frac{3}{2} - \frac{1}{2} - 2 \cos A \cos B \cos C \right\}$$

$$= 4R^2 \{ 1 - 2 \cos A \cos B \cos C \}$$

## SECTION—III

### OBJECTIVE TYPE (ONLY ONE CORRECT ANSWER)

1. If in a  $\Delta ABC$ ,  $c = 2b$  and  $\angle C = \angle B + \frac{\pi}{3}$ , then the measure of  $\angle A$  is
  - (a)  $\frac{\pi}{2}$
  - (b)  $\frac{\pi}{3}$
  - (c)  $\frac{\pi}{6}$
  - (d)  $\frac{\pi}{4}$
2. In a  $\Delta ABC$ ,  $\angle B = \frac{\pi}{8}$  and  $\angle C = \frac{5\pi}{8}$  and the altitude  $AD = h$ . Then  $h : a$  is equal to
  - (a) 1:2
  - (b) 2:1
  - (c) 1:4
  - (d) None of these
3. Which of the following pieces of data does not determine a unique  $\Delta ABC$ ; ( $R =$  circumradius)?
  - (a)  $a, \sin A, \sin B$
  - (b)  $a, b, c$
  - (c)  $a, \sin B, R$
  - (d)  $a, \sin A, R$
4. If semiperimeter of a triangle is 15, then the value of :  $(b + c) \cos (B + C) + (c + a) \cos (C + A) + (a + b) \cos (A + B)$  is equal to
  - (a) 15
  - (b) 30
  - (c) cannot be determined
  - (d) None of these
5. If in a  $\Delta ABC$ ,  $\frac{a}{\cos A} = \frac{b}{\cos B}$ , then
  - (a)  $2 \sin A \sin B \sin C = 1$
  - (b)  $\sin^2 A + \sin^2 B = \sin^2 C$
  - (c)  $2 \sin A \cos B = \sin C$
  - (d) None of these
6. In a  $\Delta ABC$ , the value of  $a^2 (\sin^2 B - \sin^2 C) + b^2 (\sin^2 C - \sin^2 A) + c^2 (\sin^2 A - \sin^2 B)$  is
  - (a)  $2 \sum a^2 b^2$
  - (b)  $2(a^2 + b^2 + c^2)$
  - (c)  $(a + b + c)^2$
  - (d) 0
7. In a  $\Delta ABC$ , the tangent of half the difference of two angles is one-third the tangent of half the sum of the two angles. The possible ratio of the sides opposite the angles is
  - (a) 2 : 3
  - (b) 1 : 3
  - (c) 1 : 2
  - (d) 3 : 4.
8. In a  $\Delta ABC$   $a \cos^2 C/2 + c \cos^2 A/2 = 3b/2$ , the sides of the triangle
  - (a) are in A.P.
  - (b) are in G.P.
  - (c) are in H.P.
  - (d) satisfy  $a = c$
9. In a  $\Delta ABC$ , the value of  $\frac{a \cos A + b \cos B + c \cos C}{a + b + c}$  is equal to
  - (a)  $R/r$
  - (b)  $R/2r$
  - (c)  $r/R$
  - (d)  $2r/R$
10. If in a  $\Delta ABC$ ;  $\sin C + \cos C + \sin(2B + C) - \cos(2B + C) = 2\sqrt{2}$ , then
  - (a) triangle is right angled and scalene
  - (b) triangle is equilateral
  - (c) triangle is isosceles and acute angled
  - (d) triangle is isosceles right angled
11. In a triangle  $ABC$ ,  $2ac \sin \frac{A-B+C}{2}$  is equal to
  - (a)  $a^2 + b^2 - c^2$
  - (b)  $c^2 + a^2 - b^2$
  - (c)  $b^2 - c^2 - a^2$
  - (d)  $c^2 - a^2 - b^2$
12. If the radius of the circumcircle of an isosceles triangle  $ABC$  is equal to  $AB = AC$ , then the angle  $A$  is
  - (a)  $\frac{\pi}{6}$
  - (b)  $\frac{\pi}{3}$
  - (c)  $\frac{\pi}{2}$
  - (d)  $\frac{2\pi}{3}$
13. In an isosceles triangle  $ABC$ ,  $AB = AC$ . If vertical angle  $A$  is  $20^\circ$ , then  $a^3 + b^3$  is equal to
  - (a)  $3ac^2$
  - (b)  $3a^2b$
  - (c)  $abc$
  - (d) None of these
14. Three vertical poles of heights  $h_1, h_2$  and  $h_3$  at the vertices  $A, B$  and  $C$  of a  $\Delta ABC$  subtend angles  $\alpha, \beta$  and  $\gamma$  respectively at the circumcentre of the triangle. If  $\cot \alpha, \cot \beta, \cot \gamma$  are in A.P., then heights  $h_1, h_2, h_3$  are in
  - (a) AP
  - (b) GP
  - (c) HP
  - (d) none of these.
15. The angle of elevation of the top of a hill from each of the vertices  $A, B, C$  of a horizontal triangle is  $\alpha$ . The height of the hill is
  - (a)  $b \tan \alpha \cdot \operatorname{cosec} B$
  - (b)  $\frac{1}{2} a \tan \alpha \cdot \operatorname{cosec} A$
  - (c)  $\frac{1}{2} c \tan \alpha \cdot \operatorname{cosec} C$
  - (d) None of these.



3.72 > Trigonometry

16. If the median  $AD$  of a triangle  $ABC$  makes an angle  $\alpha$  with  $AB$ , then  $\sin(A - \alpha)$  is equal to
- (a)  $\frac{b \sin \alpha}{c}$  (b)  $\frac{c \sin \alpha}{b}$   
 (c)  $\frac{b}{c \sin \alpha}$  (d)  $\frac{c}{b \sin \alpha}$
17. If the area of a  $\Delta ABC$  be  $\lambda$ , then  $a^2 \sin 2B + b^2 \sin 2A$  is equal to  
 (a)  $2\lambda$  (b)  $\lambda$   
 (c)  $4\lambda$  (d) None of these
18. In a  $\Delta ABC$ ,  $2s =$  perimeter and  $R =$  circumradius. Then  $s/R$  is equal to  
 (a)  $\sin A + \sin B + \sin C$   
 (b)  $\cos A + \cos B + \cos C$   
 (c)  $\sin(A/2) + \sin(B/2) + \sin(C/2)$   
 (d) None of these
19. In a  $\Delta ABC$ , the sides are in the ratio 4:5:6. The ratio of the circumradius and the inradius is equal to  
 (a) 8:7 (b) 3:2  
 (c) 7:3 (d) 16:7
20. In a triangle  $ABC$ ,  $\tan \frac{A}{2} = \frac{5}{6}$ ,  $\tan \frac{C}{2} = \frac{2}{5}$ , then  
 (a)  $a, c, b$  are in A.P. (b)  $a, b, c$  are in A.P.  
 (c)  $b, a, c$  are in A.P. (d)  $a, b, c$  are in G.P.
21. In a triangle  $ABC$ ,  $\angle C = 60^\circ$ ,  $\angle A = 75^\circ$ . If  $D$  is a point on  $AC$  such that area of  $\Delta BAD$  is  $\sqrt{3}$  times that of  $\Delta BCD$ , then  $\angle ABD$  is  
 (a)  $30^\circ$  (b)  $15^\circ$   
 (c)  $22\frac{1}{2}^\circ$  (d) None of these
22. In a  $\Delta ABC$ , if  $b + c = 3a$ , then the value of  $\cot B/2 \cot C/2$  is  
 (a) 1 (b) 2  
 (c) 3 (d) 3
23. In a  $\Delta ABC$ ,  $\angle A = \frac{2\pi}{3}$ ,  $b - c = 3\sqrt{3}$  cm and ar ( $\Delta ABC$ ) =  $\frac{9\sqrt{3}}{2}$  cm<sup>2</sup>. Then  $a$  is  
 (a)  $6\sqrt{3}$  cm (b) 9 cm  
 (c) 18 cm (d) none of these
24. In a  $\Delta ABC$ ,  $B = 90^\circ$ ,  $AC = h$  and the length of the perpendicular from  $B$  to  $AC$  is  $p$  such that  $h = 4p$ . If  $AB < BC$ , then  $\angle C$  has the measure
- (a)  $\frac{5\pi}{12}$  (b)  $\frac{\pi}{6}$   
 (c)  $\frac{\pi}{12}$  (d) none of these
25. In an isosceles right triangle  $ABC$ ,  $\angle B = 90^\circ$ ,  $AD$  is the median, then  $\frac{\sin \angle BAD}{\sin \angle CAD}$  is  
 (a)  $1/\sqrt{2}$  (b)  $\sqrt{2}$   
 (c) 1 (d) None of these
26. In a triangle  $ABC$ ,  $(a + b + c)(b + c - a) = k(bc)$  if  
 (a)  $k < 0$  (b)  $k > 6$   
 (c)  $0 < k < 4$  (d)  $k > 4$
27. If in a triangle  $\left(1 - \frac{r_1}{r_2}\right)\left(1 - \frac{r_1}{r_3}\right) = 2$ , then the triangle is  
 (a) right angled (b) isosceles  
 (c) equilateral (d) None of these
28. If in  $\Delta ABC$ ,  $\frac{a \cos A + b \cos B + c \cos C}{a \sin B + b \sin C + c \sin A} = \frac{a + b + c}{9R}$ , then the triangle  $ABC$  is  
 (a) isosceles (b) equilateral  
 (c) right angled (d) None of these
29. In a triangle if  $r_1 > r_2 > r_3$ , then  
 (a)  $a > b > c$  (b)  $a < b < c$   
 (c)  $a > b$  and  $b < c$  (d)  $a < b$  and  $b > c$
30. The sides of a triangle are in the ratio 3 : 4 : 5, the relation between  $r$  and  $R$  for the triangle is  
 (a)  $r = \frac{R}{2}$  (b)  $r = \frac{2R}{5}$   
 (c)  $r = \frac{R}{5}$  (d) None of these
31. If in a triangle  $\frac{r}{r_1} = \frac{r_2}{r_3}$ , where  $r, r_1, r_2, r_3$  have their usual meanings, then  
 (a)  $\angle A = 90^\circ$  (b)  $\angle B = 90^\circ$   
 (c)  $\angle C = 90^\circ$  (d) None of these
32. Let in  $\Delta ABC$ ,  $x, y, z$  are the lengths of altitudes drawn from  $A, B, C$  respectively. If  $x, y, z$  are in A.P. then  
 (a)  $\cos A, \cos B, \cos C$  are in A.P.  
 (b)  $\cos A, \cos B, \cos C$  are in H.P.  
 (c)  $\sin A, \sin B, \sin C$  are in H.P.  
 (d)  $\sin A, \sin B, \sin C$  are in A.P.

33. In an acute angled triangle  $ABC$  if  $\cos A, 1 - \cos B, \cos C$  are in A.P. and  $\sin A + \sin C = 1$ , then  $\angle B$  is equal to
- (a)  $\frac{\pi}{4}$  (b)  $\frac{\pi}{3}$   
 (c)  $\frac{\pi}{6}$  (d) None of these
34. A vertical pole  $PO$  is standing at the centre  $O$  of a square  $ABCD$ . If  $AC$  subtends an angle  $90^\circ$  at the top,  $P$ , of the pole, then the angle subtended by a side of the square at  $P$  is
- (a)  $45^\circ$  (b)  $30^\circ$   
 (c)  $60^\circ$  (d) none of these.
35. A vertical lamp-post of height 9 metres stands at a corner of a rectangular field. The angle of elevation of its top from the farthest corner is  $30^\circ$ , while from another corner it is  $45^\circ$ . The area of the field is
- (a)  $81\sqrt{2}$  metre<sup>2</sup> (b)  $9\sqrt{2}$  metre<sup>2</sup>  
 (c)  $81\sqrt{3}$  metre<sup>2</sup> (d)  $9\sqrt{3}$  metre<sup>2</sup>.
36. In a  $\Delta ABC$ , the sides  $a, b$  and  $c$  are such that they are the roots of  $x^3 - 11x^2 + 38x - 40 = 0$ . Then  $\frac{\cos A}{a} + \frac{\cos B}{b} + \frac{\cos C}{c}$  is equal to
- (a)  $3/4$  (b) 1  
 (c)  $3/2$  (d)  $9/16$
37.  $AD$  is a median of the  $\Delta ABC$ . If  $AE$  and  $AF$  are medians of the triangles  $ABD$  and  $ADC$  respectively, and  $AD = m_1, AE = m_2, AF = m_3$ , then  $\frac{a^2}{8}$  is equal to
- (a)  $m_2^2 + m_3^2 - 2m_1^2$  (b)  $m_1^2 + m_2^2 - 2m_3^2$   
 (c)  $m_2^2 + m_3^2 - m_1^2$  (d) None of these
38. The ratio of the distances of the orthocentre of an acute angled  $\Delta ABC$  from the sides  $BC, AC$  and  $AB$  is.
- (a)  $\cos A : \cos B : \cos C$  (b)  $\sin A : \sin B : \sin C$   
 (c)  $\sec A : \sec B : \sec C$  (d) None of these
39. If for a  $\Delta ABC, \cot A \cdot \cot B \cdot \cot C > 0$ , then the triangle is
- (a) right angled  
 (b) acute angled  
 (c) obtuse angled  
 (d) all these options are possible.
40. In a triangle with one angle of  $120^\circ$ , the length of the sides form an A.P. If the length of the greatest side is 7 cm, the area of the triangle is
- (a)  $3\sqrt{(15/4)}$  cm<sup>2</sup> (b)  $15\sqrt{3/4}$  cm<sup>2</sup>  
 (c)  $15/4$  cm<sup>2</sup> (d) None of these
41. If the radius of the circum-circle of an isosceles triangle  $PQR$  is equal to  $PQ (= PR)$ , then the angle  $P$  is
- (a)  $\pi/6$  (b)  $\pi/3$   
 (c)  $\pi/2$  (d)  $2\pi/3$
42. In a right-angled triangle, the hypotenuse is  $2\sqrt{2}$  times the length of perpendicular drawn from the opposite vertex on the hypotenuse. Then the other two angles are
- (a)  $\pi/3, \pi/6$  (b)  $\pi/4, \pi/4$   
 (c)  $\pi/8, 3\pi/8$  (d)  $\pi/12, 5\pi/12$
43. If  $a, b, c, d$  are the sides of a quadrilateral, then the value of  $\frac{a^2 + b^2 + c^2}{d^2}$  is always greater than
- (a) 1 (b)  $1/2$   
 (c)  $1/3$  (d)  $1/4$
44. If  $a, b$  and  $c$  are sides of a triangle such that  $b \cdot c = k^2$ , then
- (a)  $a \leq 2k \sin(A/2)$  (b)  $a \geq 2k \sin(A/2)$   
 (c)  $a \geq 2k \sin(A/4)$  (d)  $a \leq 2k \sin(A/4)$
45. If exradii of a  $\Delta ABC$  are 3, 4 and 6, then its inradius is
- (a)  $\frac{3}{4}$  (b)  $\frac{4}{3}$   
 (c)  $\frac{5}{6}$  (d) None of these
46. A circle of radius 4 unit is inscribed in an equilateral triangle  $ABC$ . Sides  $AB$  and  $AC$  of triangle are produced and a circle is drawn touching the sides  $BC$  and produced part of sides  $AB$  and  $AC$ . The area of the circle drawn is
- (a)  $16\pi$  sq. unit (b)  $64\pi$  sq. unit  
 (c)  $144\pi$  sq. unit (d)  $256\pi$  sq. unit
47. If in a triangle  $ABC, \angle C = 90^\circ$ , then the maximum value of  $\sin A \sin B$  is
- (a)  $1/2$  (b) 1  
 (c) 2 (d) None of these
48. If  $p_1, p_2, p_3$  are the altitude of a  $\Delta ABC$  and  $2s$  denotes its perimeter then  $1/p_1 + 1/p_2 + 1/p_3$  is equal to
- (a)  $\Delta/s$  (b)  $s/\Delta$   
 (c)  $s \cdot \Delta$  (d) None of these
49. The radius of the circle passing through the centre of incircle of  $ABC$  and through the end points of  $BC$  is given by
- (a)  $\frac{a}{2}$  (b)  $\frac{a}{2} \sec A/2$   
 (c)  $\frac{a}{2} \sin A$  (d)  $a \sec A/2$

3.74 > Trigonometry

50. In a  $\triangle ABC$ ,  $a, b, A$  are given and  $c_1, c_2$  are two values of the third side  $c$ . The sum of the areas of two triangles with sides  $a, b, c_1$  and  $a, b, c_2$  is  
 (a)  $(1/2) b^2 \sin 2A$  (b)  $(1/2) a^2 \sin 2A$   
 (c)  $b^2 \sin 2A$  (d) None of these
51. In a  $\triangle ABC$ ,  $A = 90^\circ$ . Then  $\tan^{-1} \frac{b}{a+c} + \tan^{-1} \frac{c}{a+b}$  is equal to  
 (a)  $\pi/4$  (b)  $\pi/2$   
 (c)  $\tan^{-1} \frac{a}{b+c}$  (d) none of these.
52. If  $BD, BE$  and  $CF$  are the medians of a  $\triangle ABC$  then  $(AD^2 + BE^2 + CF^2) : (BC^2 + CA^2 + AB^2)$  is equal to  
 (a) 4 : 3 (b) 3 : 2  
 (c) 3 : 4 (d) 2 : 3.
53. In any triangle  $ABC$ ;  $\frac{a^2 + b^2 + c^2}{R^2}$  has the maximum value  
 (a) 3 (b) 6  
 (c) 9 (d) None of these
54. A 6-ft-tall man finds that the angle of elevation of the top of a 24-ft-high pillar and the angle of depression of its base are complementary angles. The distance of the man from the pillar is  
 (a)  $2\sqrt{3}$  ft (b)  $8\sqrt{3}$  ft  
 (c)  $6\sqrt{3}$  ft (d) none of these.
55. A rocket of height  $h$  metres is fired vertically upwards. Its velocity at time  $t$  seconds is  $(2t + 3)$  metres/second. If the angle of elevation of the top of the rocket from a point on the ground after 1 second of firing is  $\pi/6$  and after 3 seconds it is  $\pi/3$ , then the distance of the point from the rocket is  
 (a)  $14\sqrt{3}$  metres  
 (b)  $7\sqrt{3}$  metres  
 (c)  $2\sqrt{3}$  metres  
 (d) cannot be found without the value of  $h$ .
56. A piece of paper in the shape of a sector of a circle of radius 10 cm and of angle  $216^\circ$  just covers the lateral surface of a right circular cone of vertical angle  $2\theta$ . Then  $\sin \theta$  is  
 (a)  $3/5$  (b)  $4/5$   
 (c)  $3/4$  (d) None of these.
57. The angle of elevation of the top of a vertical pole when observed from each vertex of a regular hexagon is  $\pi/3$ . If the area of the circle circumscribing the hexagon be  $A$  (metre)<sup>2</sup> then the area of the hexagon is  
 (a)  $\frac{3\sqrt{3}}{8} A$  metre<sup>2</sup> (b)  $\frac{\sqrt{3}}{\pi} A$  metre<sup>2</sup>  
 (c)  $\frac{3\sqrt{3}}{4\pi} A$  metre<sup>2</sup> (d)  $\frac{3\sqrt{3}}{2\pi} A$  metre<sup>2</sup>.
58. A vertical lamp-post, 6 m high, stands at a distance of 2 m from a wall, 4 m high. A 1.5-m-tall man starts to walk away from the wall on the other side of the wall, in line with the lamp-post. The maximum distance to which the man can walk remaining in the shadow is  
 (a)  $\frac{5}{2} m$  (b)  $\frac{3}{2} m$   
 (c)  $4m$  (d) none of these.
59. A circular ring of radius 3 cm is suspended horizontally from a point 4 cm vertically above the centre by 4 strings attached at equal intervals to its circumference. If the angle between two consecutive strings be  $\theta$  then  $\cos \theta$  is  
 (a)  $4/5$  (b)  $4/25$   
 (c)  $16/25$  (d) none of these.
60. A flagstaff stands vertically on a pillar, the height of the flagstaff being double the height of the pillar. A man on the ground at a distance finds that both the pillar and the flagstaff subtend equal angles at his eyes. The ratio of the height of the pillar and the distance of the man from the pillar, is (neglecting the height of man)  
 (a)  $\sqrt{3} : 1$  (b)  $1 : 3$   
 (c)  $1 : \sqrt{3}$  (d)  $\sqrt{3} : 2$

## SECTION-IV

### OBJECTIVE TYPE (MORE THAN ONE CORRECT ANSWERS)

1. If two sides of a  $\triangle$  are  $\sqrt{12}$  and  $\sqrt{8}$ , the angle opposite to the shorter side is  $45^\circ$ , then the third side is  
 (a)  $2\sqrt{2} - \sqrt{6}$  (b)  $\sqrt{2} + \sqrt{6}$   
 (c)  $\sqrt{20 - 8\sqrt{3}}$  (d) None of these

2. In a triangle, the lengths of the two larger sides are 10 and 9 respectively. If the angles are in A.P., then the length of third side can be  
 (a)  $5 - \sqrt{6}$  (b)  $3\sqrt{3}$   
 (c) 5 (d)  $5 + \sqrt{6}$

3. If  $l$  is the median from the vertex  $A$  to side  $BC$  of a  $\Delta ABC$ , then
- $4l^2 = 2b^2 + 2c^2 - a^2$
  - $4l^2 = b^2 + c^2 + 2bc \cos A/2$
  - $4l^2 = a^2 + 4bc \cos A$
  - $4l^2 = (2s - a)^2 - 4bc \sin^2 A/2$
4. There exists a triangle  $ABC$  satisfying the conditions:
- $b \sin A = a, A < \pi/2$
  - $b \sin A > a, A > \pi/2$
  - $b \sin A > a, A < \pi/2$
  - $b \sin A < a, b > a, A < \pi/2$
5. Given an isosceles triangle with equal sides of length  $b$  base angle  $\alpha < \pi/4$ .  $r$  the radii and  $O, I$  the centres of the circumcircle and incircle respectively. Then
- $R = b/2 \operatorname{cosec} \alpha$
  - $\Delta = 2b^2 \sin 2\alpha$
  - $r = \frac{b \sin 2\alpha}{4(1 + \cos \alpha)}$
  - None of these
6. Three equal circles each of radius  $r$  touch one another. The radius of the circle touching all the three given circles  $DEF$  is
- $(2 - \sqrt{3})r$
  - $\frac{(2 + \sqrt{3})}{\sqrt{3}}r$
  - $\frac{(2 - \sqrt{3})}{\sqrt{3}}r$
  - $(2 - \sqrt{3})r$
7. In a triangle  $\frac{\sin A}{\sin C} = \frac{\sin(A - B)}{\sin(B - C)}$ , then
- $\cot A, \cot B, \cot C$  are in A.P.
  - $\sin 2A, \sin 2B, \sin 2C$  are in A.P.
  - $\cos 2A, \cos 2B, \cos 2C$  are in A.P.
  - $a \sin A, b \sin B, c \sin C$  are in A.P.
8. If in a triangle  $ABC, \angle B = 60^\circ$  then
- $(a - b)^2 = c^2 - ab$
  - $(b - c)^2 = a^2 - bc$
  - $(c - a)^2 = b^2 - ac$
  - $a^2 + b^2 + c^2 = 2b^2 + ac$
9. If  $\tan A, \tan B$  are the roots of the quadratic  $abx^2 - c^2x + ab = 0$ , where  $a, b, c$  are the sides of a triangle, then
- $\tan A = a/b$  or  $b/a$
  - $\tan B = b/a$  or  $a/b$
  - $\cos C = 0$
  - $\tan A + \tan B = \frac{c^2}{ab}$
10. A man standing between two vertical posts finds that the angle subtended at his eyes by the tops of the posts is a right angle. If the heights of the two posts are two times and four times the height of the man, and the distance between them is equal to the length of the longer post, then the ratio of the distances of the man from the shorter and the longer post is
- 3 : 1
  - 2 : 3
  - 3 : 2
  - 1 : 3.
11. If the angles  $A, B$ , and  $C$  of a triangle  $ABC$  are in A.P. and the sides  $a, b, c$  are in G.P., then  $a^2, b^2, c^2$  are in
- G.P.
  - A.P.
  - H.P.
  - None of these

## SECTION-V

### ASSERTION AND REASON TYPE QUESTIONS

The questions given below consist of an assertion (A) and the reason (R). Use the following key to choose the appropriate answer.

- If both assertion and reason are correct and reason is the correct explanation of the assertion.
- If both assertion and reason are correct but reason is not correct explanation of the assertion.
- If assertion is correct, but reason is incorrect
- If assertion is incorrect, but reason is correct

Now consider the following statements:

1. **A:** If in a triangle,  $\tan A : \tan B : \tan C = 1 : 2 : 3$ , then  $A = 45^\circ$   
**R:** If  $\alpha : \beta : \gamma = 1 : 2 : 3$ , then  $\alpha = 1$

2. **A:** If two sides of a triangle are 2 and 3, then its area can not exceeds 3.

**R:** Area of a triangle =  $1/2 bc \sin A$  and  $\sin A \leq 1$

3. **A:** If  $\Delta$  be the area of a triangle with side lengths  $a, b, c$ , then  $\Delta \leq \frac{1}{4} \sqrt{(a+b+c)abc}$

**R:**  $AM \geq GM$

4. **A:** In a  $\Delta ABC$ ,

if  $\cos^2 \frac{A}{2} + \cos^2 \frac{B}{2} + \cos^2 \frac{C}{2} = y \left( x^2 + \frac{1}{x^2} \right)$ , then

the maximum value of  $y$  is  $\frac{9}{8}$

**R:** In a  $\Delta ABC$ ,  $\sin \frac{A}{2} \cdot \sin \frac{B}{2} \cdot \sin \frac{C}{2} \leq \frac{1}{8}$

3.76 > Trigonometry

5. **A:** The statement that circumradius and inradius of a triangle are 12 and 8 respectively can not be correct.  
**R:** Circumradius  $\geq 2$  ( inradius)
6. **A:** In acute angled triangle  $\tan A \tan B \tan C = 1$   
**R:** In obtuse angled triangle  $\tan A \tan B \tan C$  is negative quantity.
7. **A:** In any triangle  $ABC$ , the square of the length of the bisector  $AD$  is  $bc \left( 1 - \frac{a^2}{(b+c)^2} \right)^{1/2}$

- R:** In any triangle  $ABC$ , length of bisector  $AD$  is  $\frac{2bc}{(b+c)} \cos(A/2)$
8. **A:** In any right angled triangle  $\frac{a^2 + b^2 + c^2}{R^2}$  is always equal to 8.  
**R:**  $a^2 = b^2 + c^2$  or  $b^2 = c^2 + a^2$  or  $c^2 = a^2 + b^2$
9. **A:** If  $A, B, C, D$  are angles of a cyclic quadrilateral then  $\sum \sin A = 0$   
**R:** If  $A, B, C, D$  are angles of cyclic quadrilateral then,  $\sum \cos A = 0$

## SECTION-VI

### LINKED COMPREHENSION TYPE QUESTIONS

**A:** If  $p_1, p_2, p_3$  are altitudes of a triangle  $ABC$  from the vertices  $A, B, C$  respectively and  $\Delta$  is the area of the triangle and  $s$  is semi perimeter of the triangle.

1. If  $\frac{1}{p_1} + \frac{1}{p_2} + \frac{1}{p_3} = \frac{1}{2}$ , then the least value of  $p_1 p_2 p_3$  is  
 (a) 8 (b) 27  
 (c) 125 (d) 216
2. The value of  $\frac{\cos A}{p_1} + \frac{\cos B}{p_2} + \frac{\cos C}{p_3}$  is  
 (a)  $\frac{1}{r}$  (b)  $\frac{1}{R}$   
 (c)  $\frac{a^2 + b^2 + c^2}{2R}$  (d)  $\frac{1}{\Delta}$
3. The minimum value of  $\frac{b^2 p_1}{c} + \frac{c^2 p_2}{a} + \frac{a^2 p_3}{b}$  is  
 (a)  $\Delta$  (b)  $2\Delta$   
 (c)  $3\Delta$  (d)  $6\Delta$
4. The value of  $p_1^{-2} + p_2^{-2} + p_3^{-2}$  is  
 (a)  $\frac{(\sum a)^2}{4\Delta^2}$  (b)  $\frac{(\prod a)^3}{8\Delta^3}$   
 (c)  $\frac{\sum a^2}{4\Delta^2}$  (d)  $\frac{\pi a^2}{8\Delta^2}$
5. In the triangle  $ABC$ , the altitudes are in  $AP$ , then  
 (a)  $a, b, c$  are in AP  
 (b)  $a, b, c$  are in HP

- (c)  $a, b, c$  are in GP  
 (d) angles  $A, B, C$  are in AP.
- B:** A polygon has  $n$  sides. If all the sides and all the angles are same, then this polygon is called regular polygon. Let  $A_1, A_2, A_3, \dots, A_n$  be a regular polygon of  $n$  sides.  $R$  be the radius of circumscribed circle of regular polygon and  $r$  be the radius of inscribed circle of regular polygon.
6. The value of  $A_j A_j$  ( $j = 1, 2, 3, \dots, n$ ) is  
 (a)  $2R \sin \left\{ (j-1) \frac{\pi}{2n} \right\}$   
 (b)  $R \sin \left\{ (j-1) \frac{2\pi}{n} \right\}$   
 (c)  $2R \sin \left\{ (j-1) \frac{\pi}{n} \right\}$   
 (d)  $R \sin \left\{ (j-1) \frac{\pi}{n} \right\}$
7. The value of  $r$  is  
 (a)  $\frac{a}{2} \tan \left( \frac{\pi}{n} \right)$  (b)  $\frac{a}{2} \cot \left( \frac{\pi}{n} \right)$   
 (c)  $\frac{a}{4} \tan \left( \frac{\pi}{2n} \right)$  (d)  $\frac{a}{2} \cot \left( \frac{\pi}{2n} \right)$
8. The value of  $r + R$  is  
 (a)  $\frac{a}{2} \cot \left( \frac{\pi}{n} \right)$  (b)  $a \cot \left( \frac{\pi}{2n} \right)$   
 (c)  $\frac{a}{4} \cot \left( \frac{\pi}{2n} \right)$  (d)  $\frac{a}{2} \cot \left( \frac{\pi}{2n} \right)$

9. The area of a regular polygon of  $n$  sides is
- (a)  $\frac{nR^2}{2} \sin\left(\frac{2\pi}{n}\right)$  (b)  $nR^2 \tan\left(\frac{\pi}{n}\right)$   
 (c)  $\frac{nr^2}{2} \sin\left(\frac{2\pi}{n}\right)$  (d)  $nr^2 \tan\left(\frac{2\pi}{n}\right)$
10. A regular pentagon and a regular decagon have the same perimeter, then their areas are in the ratio
- (a)  $\sqrt{5} : 1$  (b)  $\sqrt{5} : 2$   
 (c)  $1 : \sqrt{5}$  (d)  $2 : \sqrt{5}$
- C:** When any two sides and one of the opposite acute angles are given, under certain additional conditions two triangles are possible. The case when two triangles are possible is called the ambiguous case.  
 In fact when any two sides and the angle opposite to one of them are given either no triangle is possible or two triangles are possible.  
 In the ambiguous case, let  $a$ ,  $b$  and  $\angle A$  are given and  $c_1$ ,  $c_2$  are two values of the third side  $c$ .
11. Two different triangles are possible when
- (a)  $b \sin A < a$   
 (b)  $b \sin A < a$  and  $b > a$   
 (c)  $b \sin A < a$  and  $b < a$   
 (d)  $b \sin A < a$  and  $a = b$
12. The difference between two values of  $c$  is
- (a)  $2\sqrt{(a^2 - b^2)}$  (b)  $\sqrt{(a^2 - b^2)}$   
 (c)  $2\sqrt{(a^2 - b^2 \sin^2 A)}$  (d)  $\sqrt{(a^2 - b^2 \sin^2 A)}$
13. The value of  $c_1^2 - 2c_1c_2 \cos 2A + c_2^2$  is
- (a)  $4a \cos A$  (b)  $4a^2 \cos A$   
 (c)  $4a \cos^2 A$  (d)  $4a^2 \cos^2 A$
14. If  $\angle A = 45^\circ$  and in ambiguous case ( $a$ ,  $b$ ,  $A$  are given)  $c_1$ ,  $c_2$  are two values of  $c$  and if  $\theta$  the angle between the two positions of the ambiguous side  $c$ , then  $\cos \theta$  is
- (a)  $\frac{c_1c_2}{c_1^2 + c_2^2}$  (b)  $\frac{2c_1c_2}{c_1^2 + c_2^2}$   
 (c)  $\frac{\sqrt{c_1c_2}}{(c_1 + c_2)}$  (d)  $\frac{2\sqrt{c_1c_2}}{(c_1 + c_2)}$
- D:** In a triangle, if the sum of two sides is  $x$  and their product is  $y$  ( $x \geq 2\sqrt{y}$ ) such that  $(x + z)(x - z) = y$ , where  $z$  is the third side of the triangle.
15. Greatest angle of the triangle is
- (a)  $105^\circ$  (b)  $120^\circ$   
 (c)  $135^\circ$  (d)  $150^\circ$
16. Circumradius of the triangle is
- (a)  $x$  (b)  $y$   
 (c)  $z$  (d) None of these
17. Inradius of the triangle is
- (a)  $\frac{y}{2(z+x)}$  (b)  $\frac{z}{2(x+y)}$   
 (c)  $\frac{y\sqrt{3}}{(z+x)}$  (d)  $\frac{z\sqrt{3}}{(x+y)}$
18. Area of the triangle is
- (a)  $\frac{y\sqrt{3}}{4}$  (b)  $\frac{x\sqrt{3}}{4}$   
 (c)  $\frac{z\sqrt{3}}{4}$  (d) None of these
19. The sides of the triangle are
- (a)  $\frac{x \pm \sqrt{(x^2 - 4y)}}{2}$ ,  $z$  (b)  $\frac{y \pm \sqrt{(y^2 - 4z)}}{2}$ ,  $z$   
 (c)  $\frac{z \pm \sqrt{(z^2 - 4x)}}{2}$ ,  $z$  (d) None of these
- E:**  $AL$ ,  $BM$  and  $CN$  are perpendiculars from angular points of a triangle  $ABC$  on the opposite side  $BC$ ,  $CA$  and  $AB$  respectively.  $\Delta$  is the area of triangle  $ABC$ ,  $r$  and  $R$  are the inradius and circumradius, then answer the following questions.
20. If perimeters of  $\Delta LMN$  and  $\Delta ABC$  are  $\lambda$  and  $\mu$ , the value of  $\frac{\lambda}{\mu}$  is
- (a)  $\frac{r}{R}$  (b)  $\frac{R}{r}$   
 (c)  $\frac{rR}{\Delta}$  (d)  $\frac{\Delta}{rR}$
21. If areas of  $\Delta$ 's  $AMN$ ,  $BNL$  and  $CLM$  are  $\Delta_1$ ,  $\Delta_2$  and  $\Delta_3$  respectively, then the value of  $\Delta_1 + \Delta_2 + \Delta_3$  is
- (a)  $\Delta(2 + 2 \cos A \cos B \cos C)$   
 (b)  $\Delta(2 + 2 \sin A \sin B \sin C)$   
 (c)  $\Delta(1 - 2 \cos A \cos B \cos C)$   
 (d)  $\Delta(1 - 2 \sin A \sin B \sin C)$
22. If area of  $\Delta LMN$  is  $\Delta'$ , then the value of  $\frac{\Delta'}{\Delta}$  is
- (a)  $2 \sin A \sin B \sin C$  (b)  $2 \cos A \cos B \cos C$   
 (c)  $\sin A \sin B \sin C$  (d)  $\cos A \cos B \cos C$
23. Radius of the circumcircle of  $\Delta LMN$  is
- (a)  $2R$  (b)  $R$   
 (c)  $\frac{R}{2}$  (d)  $\frac{R}{4}$

3.78 > Trigonometry

24. If radius of the incircle of  $\Delta LMN$  is  $r'$ , then the value of  $r' \sec A \sec B \sec C$  is  
 (a)  $4R$  (b)  $3R$   
 (c)  $2R$  (d)  $R$

**F:** In a  $\Delta ABC$ , let D,E,F be feet of normal drawn from the vertices  $A, B, C$  to opposite sides respectively, then we have learnt earlier that the altitude AD, BE, CF are concurrent and their point of concurrency is called ortho centre denoted by H.

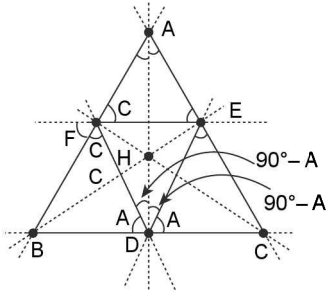

The triangle formed by joining D,E,F is called pedal triangle of  $\Delta ABC$  and  $\Delta ABC$  is excentral  $\Delta$  of  $\Delta DEF$  i.e., AD, BE, CF are internal angle bisectors of  $\Delta DEF$  where as AB, BC, CA are external angle bisectors of  $\Delta DEF$  therefore the angular point  $A, B, C$  are excentres of  $\Delta DEF$ , and also analysing the figure given we can observe many cyclic quadrilaterals and therefore very important conclusions can be drawn which may prove useful in answering following problems:

25. Orthocentre of  $\Delta ABC$  is same point as  
 (a) Circumcentre of  $\Delta DEF$   
 (b) Centroid of  $\Delta DEF$   
 (c) incentre of  $\Delta DEF$   
 (d) Radical centre of the diameter circles draw on AB, BC, CA.
26. The quadrilateral AFHE is  
 (a) a Trapezium (b) a square  
 (c) a parallelogram (d) a cyclic quadrilateral
27. Which of the following is true?  
 (a) There are 6 cyclic quadrilaterals in the shown figure  
 (b) There are 4 cyclic quadrilaterals in the shown figure  
 (c) There are 8 cyclic quadrilaterals in the shown figure  
 (d) None of these
28. Which of the following is true?  
 (a) Angles of triangle DEF are supplementary of double the opposite angle of  $\Delta ABC$ .  
 (b)  $\angle AFE = \angle AHE = \angle BFD = \angle ACB$

- (c)  $\angle BAD = \angle BED = \frac{\pi}{2} - B$   
 (d) All the above are incorrect
29. Distance of orthocentre H from corresponding vertices of  $A, B, C$  are given respectively as  
 (a)  $2R \cos A, 2R \cos B, 2R \cos C$   
 (b)  $R \cos A, R \cos B, R \cos C$   
 (c)  $a \cot A, b \cot B, c \cot C$   
 (d) None of these
30. Distance of orthocentre from corresponding sides AB, BC, CA of  $\Delta ABC$  respectively are  
 (a)  $R \cos B \cos A, R \cos B \cos C, R \cos C \cos A$   
 (b)  $2R \cos A \cos B, 2R \cos B \cos C, 2R \cos A \cos C$   
 (c)  $2R \cos A, 2R \cos B, 2R \cos C$   
 (d) None of these
31. **A:** Orthocentre divides the altitude AD in ratio AH : HD ::  $\tan B + \tan C : \tan A$   
**R:**  $AH = 2R \cos A, HD = 2R \cos B \cos C$  and  
 $\frac{HA}{HD} = \left( \frac{\sin(B+C)}{\cos B \cos C} \right) / \tan A$   
 (a) both A & R are true & R explains A correctly  
 (b) both A and R are true but R does not explains A correctly  
 (c) A is true but R is false  
 (d) A is false but R is true
32. Perimeter of pedal triangle DEF is given as  
 (a)  $\sum a \cos A$   
 (b)  $R \sum \sin 2A$   
 (c)  $4R \sin A \sin B \sin C$   
 (d)  $\frac{2\Delta}{R}$  where  $\Delta$  and R are area and circum radius of  $\Delta ABC$
33. Area of PEDAL triangle DEF ( $\Delta_p$ ) is given as  
 (a)  $2\Delta \cos A \cos B \cos C$   
 (b)  $\frac{1}{2} R^2 \sin 2A \sin 2B \sin 2C$   
 (c)  $R \sin 2A \sin 2B \sin 2C$   
 (d) None of these
34. Which of the following is true about pedal triangle DEF?  
 (a) Circum circle of triangle DEF is called nine point circle of  $\Delta ABC$   
 (b) Circum circle of  $\Delta DEF$  has radius  $R_p = \frac{R}{2}$   
 (c) in radius of  $\Delta DEF$   $r_p = 2R \cos A \cos B \cos C$   
 (d) For equilateral  $\Delta ABC$   $R_p = r = \frac{R}{2} = 2r_p$

## SECTION-VII

### MATRIX MATCH TYPE QUESTIONS

#### 1. Column-I

- (i) In a triangle  $ABC$ , if  $a^4 - 2(b^2 + c^2)a^2 + b^4 + b^2c^2 + c^4 = 0$ , then  $\angle A$  is
- (ii) In a triangle  $ABC$ , If  $a^4 + b^4 + c^4 = a^2b^2 + 2b^2c^2 + 2c^2a^2$ , then  $\angle C$  is
- (iii) In a triangle  $ABC$ , If  $a^4 + b^4 + c^4 + 2a^2c^2 = 2a^2b^2 + 2b^2c^2$ , then  $\angle B$  is

#### Column-II

- (a)  $30^\circ$   
 (b)  $60^\circ$   
 (c)  $90^\circ$   
 (d)  $120^\circ$   
 (e)  $150^\circ$

#### 2. Column-I

- (i) In a  $\Delta ABC$ , if  $2a^2 + b^2 + c^2 = 2ac + 2ab$ , then
- (ii) In a  $\Delta ABC$ , if  $a^2 + b^2 + c^2 = \sqrt{2}b(c + a)$ , then
- (iii) In a  $\Delta ABC$ , if  $a^2 + b^2 + c^2 = bc + ca \sqrt{3}$

#### Column-II

- (a)  $\Delta ABC$  is equilateral triangle  
 (b)  $\Delta ABC$  is right angled triangle  
 (c)  $\Delta ABC$  is scalane triangle

- (d)  $\Delta ABC$  is isosceles right angled triangle  
 (e) Angles  $B, C, A$  are in A.P.

3. In a triangle  $ABC$ , AD is perpendicular to BC and DE is perpendicular to AB

#### Column-I

- (i) area of  $\Delta ADB$   
 (ii) area of  $\Delta ADC$   
 (iii) area of  $\Delta ADE$   
 (iv) area of  $\Delta BDC$

#### Column-II

- (a)  $\left(\frac{b^2}{4}\right) \sin 2C$   
 (b)  $\left(\frac{c^2}{4}\right) \cos^2 B \sin 2B$   
 (c)  $\left(\frac{c^2}{4}\right) \sin 2B$   
 (d)  $\left(\frac{c^2}{4}\right) \sin^2 B \sin 2B$   
 (e)  $\left(\frac{b^2}{4}\right) \sin^2 C \sin^2 B$

## SECTION VIII

### INTEGER TYPE QUESTIONS

1. If the sides of a triangle are  $3 + \sqrt{3}$ ,  $2\sqrt{3}$  and  $\sqrt{6}$  then find the difference of the greatest angle and the least angle in degrees.
2. A tower subtends angle  $\theta$ ,  $2\theta$  and  $3\theta$  at three points  $A, B$  and  $C$  respectively, lying on a horizontal line through the foot of the tower, then the ratio  $\frac{AB}{BC}$  equals  $\frac{\sin \lambda \theta}{\sin \mu \theta}$ ; then evaluate  $(\lambda + \mu)$ .
3. G be the centroid of triangle ABC with  $BC = 3$  and  $AC = 4$ . Medians AD and BE are perpendicular to each other.  
 A circle is drawn by taking AG as diameter which intersects AB at M, then find the value of  $BC \cdot AB \cdot BM$ .

4. In a  $\Delta ABC$ , the angle  $B > A$ . If the values of the angles of  $A$  and  $B$  satisfy the equation  $3\sin x - 4\sin^3 x - k = 0$ ,  $0 < k < 1$ , then find the value of  $C$  in degrees.
5. If the value of expression 
$$\frac{(a+b+c)(b+c-a)(c+a-b)(a+b-c)}{4b^2c^2} = (\sin \lambda A)^\mu;$$
 then evaluate  $\lambda + \mu$ .
6. If in a  $\Delta ABC$ ,  $\cos A + \cos B + \cos C = k + r/R$ ; where  $r = \text{inradius}$  and  $R = \text{circumradius}$  of  $\Delta ABC$ . then find the value of  ${}^{k+\mu}\sqrt{196}$ .
7. The sides of a triangle are  $a = 2x + 3$ ,  $b = x^2 + 3x + 3$ ,  $c = x^2 + 2x$ , then find angle  $B$  in degrees.
8. In  $\Delta ABC$  if  $b^2 + c^2 = 2a^2$ , then evaluate  $\frac{8\cot A}{\cot B + \cot C}$
9. In  $\Delta ABC$ , find the minimum value of  $\tan^2(A/2) + \tan^2(B/2) + \tan^2(C/2)$ .



**3.80** > Trigonometry

10. If in a  $\Delta ABC$ ,  $\angle A = 60^\circ$ , then find the value of  $\left(1 + \frac{a}{c} + \frac{b}{c}\right)\left(1 + \frac{c}{b} - \frac{a}{b}\right)$ .
11. In a triangle  $ABC$ , the line joining the circumcentre to the incentre is parallel to  $BC$ , then evaluate  $\cos B + \cos C$
12. In  $\Delta ABC$  if the maximum of  $\frac{a \cos^2 \frac{A}{2} + b \cos^2 \frac{B}{2} + c \cos^2 \frac{C}{2}}{a + b + c}$  is  $\lambda$ , then evaluate  $4\lambda$
13. Tangents are drawn to the incircle of  $\Delta ABC$  which are parallel to its sides. If  $x, y, z$  are the length of the

tangents intercepted between the sides of triangle and  $a, b, c$  that of sides  $BC, CA$  and  $AB$  respectively, then find  $\frac{2x}{a} + \frac{2y}{b} + \frac{2z}{c}$ .

14. In a  $\Delta ABC$ , the median to the side  $BC$  is of length  $\frac{1}{\sqrt{11-6\sqrt{3}}}$  and it divides angle  $A$  into the angles of measure  $\frac{\pi}{6}$  and  $\frac{\pi}{4}$ . Find the length of side  $BC$ .
15. In any triangle  $ABC$ , find the minimum value of  $\frac{r_1 + r_2 + r_3}{r}$ , where  $r, r_1, r_2, r_3$  are respectively the radius of incircle and escribed circles.

## Answer Keys

### SECTION-III

- |         |         |         |         |         |         |         |         |         |         |
|---------|---------|---------|---------|---------|---------|---------|---------|---------|---------|
| 1. (b)  | 2. (a)  | 3. (d)  | 4. (d)  | 5. (c)  | 6. (d)  | 7. (c)  | 8. (a)  | 9. (c)  | 10. (d) |
| 11. (b) | 12. (d) | 13. (a) | 14. (c) | 15. (b) | 16. (b) | 17. (c) | 18. (a) | 19. (d) | 20. (b) |
| 21. (a) | 22. (b) | 23. (b) | 24. (c) | 25. (b) | 26. (c) | 27. (a) | 28. (b) | 29. (a) | 30. (b) |
| 31. (c) | 32. (c) | 33. (c) | 34. (c) | 35. (a) | 36. (d) | 37. (a) | 38. (c) | 39. (b) | 40. (b) |
| 41. (d) | 42. (c) | 43. (c) | 44. (b) | 45. (b) | 46. (c) | 47. (a) | 48. (b) | 49. (b) | 50. (a) |
| 51. (a) | 52. (c) | 53. (c) | 54. (c) | 55. (b) | 56. (a) | 57. (d) | 58. (a) | 59. (c) | 60. (c) |

### SECTION-IV

- |            |               |           |           |           |           |              |           |                 |
|------------|---------------|-----------|-----------|-----------|-----------|--------------|-----------|-----------------|
| 1. (b, c)  | 2. (a, d)     | 3. (a, d) | 4. (a, d) | 5. (a, c) | 6. (b, c) | 7. (a, c, d) | 8. (c, d) | 9. (a, b, c, d) |
| 10. (a, d) | 11. (a, b, c) |           |           |           |           |              |           |                 |

### SECTION-V

- |        |        |        |        |        |        |        |        |        |
|--------|--------|--------|--------|--------|--------|--------|--------|--------|
| 1. (c) | 2. (a) | 3. (a) | 4. (d) | 5. (a) | 6. (d) | 7. (a) | 8. (a) | 9. (d) |
|--------|--------|--------|--------|--------|--------|--------|--------|--------|

### SECTION-VI

- |            |         |         |                  |            |                  |         |               |         |         |
|------------|---------|---------|------------------|------------|------------------|---------|---------------|---------|---------|
| 1. (d)     | 2. (b)  | 3. (d)  | 4. (c)           | 5. (b)     | 6. (c)           | 7. (b)  | 8. (d)        | 9. (a)  | 10. (d) |
| 11. (b)    | 12. (c) | 13. (d) | 14. (b)          | 15. (b)    | 16. (d)          | 17. (c) | 18. (a)       | 19. (a) | 20. (a) |
| 21. (c)    | 22. (b) | 23. (c) | 24. (c)          | 25. (c, d) | 26. (d)          | 27. (a) | 28. (a, b, c) |         |         |
| 29. (a, c) | 30. (b) | 31. (a) | 32. (a, b, c, d) | 33. (a, b) | 34. (a, b, c, d) |         |               |         |         |

### SECTION-VII

- |                             |                           |  |
|-----------------------------|---------------------------|--|
| 1. (i) $\rightarrow$ (b, d) | (ii) $\rightarrow$ (a, e) | (iii) $\rightarrow$ (c)                                |
| 2. (i) $\rightarrow$ (a, e) | (ii) $\rightarrow$ (b, d) | (iii) $\rightarrow$ (b, c, e)                          |
| 3. (i) $\rightarrow$ (c)    | (ii) $\rightarrow$ (a)    | (iii) $\rightarrow$ (d, e)      (iv) $\rightarrow$ (b) |

### SECTION-VIII

- |       |       |       |        |       |       |        |      |      |       |
|-------|-------|-------|--------|-------|-------|--------|------|------|-------|
| 1. 75 | 2. 4  | 3. 4  | 4. 120 | 5. 3  | 6. 14 | 7. 120 | 8. 4 | 9. 1 | 10. 3 |
| 11. 1 | 12. 3 | 13. 2 | 14. 2  | 15. 9 |       |        |      |      |       |

## HINTS AND SOLUTIONS

### TEXTUAL EXERCISE-1 (SUBJECTIVE)

1. (a) R.H.S. =  $\frac{b-c}{a} \cos \frac{A}{2}$ ; using sine rule.

$$= \frac{k \sin B - k \sin C}{K \sin A} \times \cos \frac{A}{2}$$

$$= \frac{2 \cos \left( \frac{B+C}{2} \right) \sin \left( \frac{B-C}{2} \right)}{2 \sin \frac{A}{2} \cos \frac{A}{2}} \times \cos \frac{A}{2} = \sin \left( \frac{B-C}{2} \right)$$

= L.H.S.

(b) L.H.S. =  $a(b \cos C - c \cos B) = ab \cos C - ac \cos B$

$$= ab \left( \frac{a^2 + b^2 - c^2}{2ab} \right) - ac \left( \frac{a^2 + c^2 - b^2}{2ac} \right)$$

(using cosine formula)

$$= \frac{1}{2} (a^2 + b^2 - c^2 - a^2 - c^2 + b^2) = b^2 - c^2 = \text{R.H.S.}$$

(c) R.H.S. =  $\frac{b^2 - c^2}{a^2} = \frac{\sin^2 B - \sin^2 C}{\sin^2 A}$  (By sine rule)

$$= \frac{\sin(B+C) \sin(B-C)}{\sin^2(\pi - (B+C))} = \frac{\sin(B-C)}{\sin(B+C)} = \text{L.H.S.}$$

(d) Let  $\frac{b+c}{11} = \frac{c+a}{10} = \frac{a+b}{9} = k$

$\Rightarrow b + c = 11k; c + a = 10k; a + b = 9k$   
 $\Rightarrow 2(a + b + c) = 30k \Rightarrow a + b + c = 15k$   
 $\Rightarrow a = 4k, b = 5k, c = 6k$   
 $\Rightarrow a : b : c = 4 : 5 : 6$

Now  $\cos A = \frac{b^2 + c^2 - a^2}{2bc} = \frac{25 + 36 - 16}{2(5)(6)} = \frac{45}{60} = \frac{3}{4}$

$\cos B = \frac{a^2 + c^2 - b^2}{2ac} = \frac{16 + 36 - 25}{2(4)(6)} = \frac{27}{48} = \frac{9}{16}$

$\cos C = \frac{a^2 + b^2 - c^2}{2ab} = \frac{16 + 25 - 36}{2(4)(5)} = \frac{1}{8}$

$\Rightarrow \cos A : \cos B : \cos C = \frac{3}{4} : \frac{9}{16} : \frac{1}{8} = 12 : 9 : 2$

$\Rightarrow \frac{\cos A}{12} = \frac{\cos B}{9} = \frac{\cos C}{2}$  **Hence Proved**

2. (a)  $\frac{1}{a+c} + \frac{1}{b+c} = \frac{3}{a+b+c}$

$\Rightarrow \frac{a+b+2c}{(a+c)(b+c)} = \frac{3}{a+b+c}$

$\Rightarrow (a+b+c)^2 + ac + bc + c^2 = 3ab + 3ac + 3bc + 3c^2$

$\Rightarrow a^2 + b^2 - c^2 = ab$

$\Rightarrow \frac{a^2 + b^2 - c^2}{2ab} = \frac{1}{2} \Rightarrow \cos C = \frac{1}{2} \Rightarrow C = 60^\circ$

(b) By cosine formula,  
 $a^2 + b^2 - c^2 = 2ab \cos C$  .....(i)

$b^2 + c^2 - a^2 = 2bc \cos A$  .....(ii) and

$c^2 + a^2 - b^2 = 2ca \cos B$  .....(iii)

Adding (i), (ii) and (iii) we get,

$a^2 + b^2 + c^2 = 2(bc \cos A + ca \cos B + ab \cos C)$

(c)  $\cos B = \frac{a^2 + c^2 - b^2}{2ac}; \cos C = \frac{a^2 + b^2 - c^2}{2ab}$   
 (By cosine formula)

$\sin B = \frac{b}{2R}; \sin C = \frac{c}{2R}$  (By sine Formula)

$\Rightarrow \tan B = \frac{abc}{R} \cdot \frac{1}{a^2 + c^2 - b^2}; \tan C = \frac{abc}{R} \cdot \frac{1}{a^2 + b^2 - c^2}$

$\Rightarrow (a^2 + c^2 - b^2) \tan B = (a^2 + b^2 - c^2) \tan C$

(d) R.H.S. =  $(a-b)^2 \cos^2 C/2 + (a+b)^2 \sin^2 C/2$

$= (a-b)^2 \left( \frac{1 + \cos C}{2} \right) + (a+b)^2 \left( \frac{1 - \cos C}{2} \right)$

$= \frac{(a-b)^2}{2} \left[ 1 + \frac{a^2 + b^2 - c^2}{2ab} \right] + \frac{(a+b)^2}{2} \left[ 1 - \frac{a^2 + b^2 - c^2}{2ab} \right]$

$= \frac{(a-b)^2}{2} \left[ \frac{(a+b)^2 - c^2}{2ab} \right] + \frac{(a+b)^2}{2} \left[ \frac{c^2 - (a+b)^2}{2ab} \right]$

$= \frac{1}{4(ab)} \cdot [(a+b)^2 - c^2] \cdot [(a-b)^2 - (a+b)^2]$

$= \frac{1}{4ab} [(a+b)^2 - c^2] \cdot [-4ab] = c^2 - (a+b)^2 = \text{L.H.S.}$

3. Let  $a = 8\text{cm}, b = 10\text{cm}, c = 12\text{cm}$

$\therefore$  Greatest angle  $\angle C$  and smallest angle  $\angle A$ . Also  $a^2 + b^2 - c^2, a^2 + c^2 - b^2, b^2 + c^2 - a^2 > 0$

$\Rightarrow A, B, C$  are acute angle

To prove:  $C = 2A$  or  $C - A = A$

Now,  $\cos C = \frac{a^2 + b^2 - c^2}{2ab} = \frac{64 + 100 - 144}{2(8)(10)} = \frac{1}{8}$

And  $\cos 2A = 2\cos^2 A - 1 = 2 \left[ \frac{100 + 144 - 64}{2(10)(12)} \right]^2 - 1 = \frac{1}{8}$

$\Rightarrow C = 2n\pi \pm 2A; n \in \mathbb{Z}$

$\Rightarrow C = 2A$  or  $2\pi - 2A$  (impossible)

Since otherwise  $A \in (0, \pi/2)$

$\Rightarrow 2A \in (0, \pi)$

$\Rightarrow -2A \in (-\pi, 0)$

$\Rightarrow 2\pi - 2A \in (\pi, 2\pi)$

$\Rightarrow C > \pi$ , but  $C$  is acute

$\therefore C = 2A$

4.  $\frac{\cos^2 B - \cos^2 C}{b+c} = \frac{\sin^2 C - \sin^2 B}{b+c} = \frac{k^2 c^2 - k^2 b^2}{b+c} = k^2(c-b)$

$\therefore \Sigma \frac{\cos^2 B - \cos^2 C}{b+c} = k^2 \Sigma (c-b) = 0$  **Hence Proved**

3.82 > Trigonometry

5. Given  $2\cos A = \frac{\sin B}{\sin C} \Rightarrow 2\left[\frac{b^2+c^2-a^2}{2abc}\right] = \frac{b}{c}$   
 $\Rightarrow b^2+c^2-a^2 = b^2$   
 $\Rightarrow C = a$  (as  $c, a > 0$ )  $\Rightarrow \Delta ABC$  is an isosceles  $\Delta$ .

6. (a)  $\frac{b^2-c^2}{a^2}\sin 2A + \frac{c^2-a^2}{b^2}\sin 2B + \frac{a^2-b^2}{c^2}\sin 2C = 0$   
 Consider  $\frac{b^2-c^2}{a^2}\sin 2A = \frac{b^2-c^2}{a^2}[2\sin A \cos A]$   
 $= \frac{b^2-c^2}{a^2}\left[2ak\frac{(b^2+c^2-a^2)}{2bc}\right] = \frac{k}{abc}[(b^2-c^2)(b^2+c^2-a^2)]$   
 $\Rightarrow \sum \frac{b^2-c^2}{a^2}\sin 2A = \frac{k}{abc}\sum (b^2-c^2)(b^2+c^2-a^2) = 0$   
 $= \frac{k}{abc}(\sum b^4 - \sum c^4 - \sum a^2b^2 + \sum a^2c^2) = \frac{k}{abc}(0) = 0$

(b) In  $\Delta ABC$ , to prove

(i)  $a \sin(B-C) + b \sin(C-A) + c \sin(A-B) = 0$   
 L.H.S =  $\sum a \sin(B-C)$   
 $= \sum a[\sin B \cos C - \cos B \sin C]$   
 $= \sum a\left[bk\left(\frac{a^2+b^2+c^2}{2ab}\right) - ck\left(\frac{a^2+c^2-b^2}{2ac}\right)\right]$   
 $= \sum\left[\frac{k}{2}(a^2+b^2+c^2) - \frac{k}{2}(a^2+c^2-b^2)\right]$   
 $= \frac{k}{2}\sum 2(b^2-c^2) = k\sum(b^2-c^2) = 0$  R.H.S

(ii)  $\sum \frac{a^2 \sin(B-C)}{\sin B + \sin C} = 0$

L.H.S =  $\sum \frac{a^2 \sin(B-C)}{\sin B + \sin C}$   
 $= \sum \frac{a^2(\sin B \cos C - \cos B \sin C)}{\sin B + \sin C}$   
 $= \sum \frac{a^2\left[kb\left(\frac{a^2+b^2+c^2}{2ab}\right) - kc\left(\frac{a^2+c^2-b^2}{2ac}\right)\right]}{kb+kc}$   
 $= \sum \frac{ka\left[(a^2+b^2+c^2) - (a^2+c^2-b^2)\right]}{k(b+c)}$   
 $= \sum \frac{2a(b^2-c^2)}{(b+c)}$   
 $= 2\sum a(b-c) = 2\sum(ab-ac) = 0$

(iii)  $\sum \frac{a^2 \sin(B-C)}{b^2-c^2} = \sin A + \sin B + \sin C$

L.H.S =  $\sum \frac{a^2 \sin(B-C)}{b^2-c^2} = \sum \frac{a^2(\sin B \cos C - \cos B \sin C)}{b^2-c^2}$   
 $= \sum \frac{a^2}{b^2-c^2}\left[\frac{bk(a^2+b^2+c^2)}{2ab} - \frac{ck(a^2+c^2-b^2)}{2ac}\right]$   
 $= \frac{k}{2}\sum \frac{2a}{b^2-c^2}(b^2-c^2) = k\sum a$   
 $= \sum ka = \sin A + \sin B + \sin C =$  R.H.S

7.  $\cos A + \cos B + \cos C = \frac{3}{2}$

$\Rightarrow \sum \frac{b^2+c^2-a^2}{2bc} = \frac{3}{2}$   
 $\Rightarrow \Sigma(ab^2+ac^2-a^3) = 3abc$   
 $\Rightarrow ab^2+ac^2+bc^2+ba^2+ca^2+cb^2-a^3-b^3-c^3 = 3abc$   
 $\Rightarrow ab^2+ac^2+bc^2+ba^2+ca^2+cb^2-3abc = a^3+b^3+c^3$   
 $\Rightarrow ab^2+ac^2+bc^2+ba^2+ca^2+cb^2-6abc = a^3+b^3+c^3-3abc$   
 $\Rightarrow a(b^2+ac^2-2bc) + b(c^2+a^2-2ac) + c(a^2+b^2-2ab)$   
 $= (a+b+c)(a^2+b^2+c^2-ab-bc-ca)$   
 $\Rightarrow a(b-c)^2 + b(c-a)^2 + c(a-b)^2 = \frac{(a+b+c)}{2} [(a-b)^2$   
 $+ (b-c)^2 + (c-a)^2]$   
 $\Rightarrow (a-b)^2 [2c-(a+b+c)] + (b-c)^2 [2a-(a+b+c)] +$   
 $(c-a)^2 [2b-(a+b+c)] = 0$   
 $\Rightarrow (a-b)^2 [a+b-c] + (b-c)^2 [b+c-a] + (c-a)^2 [a$   
 $+c-b] = 0$   
 $\therefore$  In a triangle sum of two sides is greater than the third side,  $a+b-c$  etc. are positive.  
 $\Rightarrow (a-b)^2 = (b-c)^2 = (c-a)^2 = 0$   
 $\Rightarrow a = b = c$   
 $\Rightarrow \Delta$  is an equilateral triangle.

8.  $\therefore A$  is an angle of  $\Delta$

$\Rightarrow A \in (0, \pi) \Rightarrow \sin A > 0$   
 Using A.M.  $\geq$  G.M. for 1,  $\sin A$  and  $\sin^2 A$ , we get  
 $\frac{\sin^2 A + \sin A + 1}{3} \geq \sqrt[3]{\sin^2 A \cdot \sin A \cdot 1}$   
 $\Rightarrow \frac{\sin^2 A + \sin A + 1}{\sin A} \geq 3$  Hence proved.

9. (a) Given,  $\frac{2\cos A}{a} + \frac{\cos B}{b} + \frac{2\cos C}{c} = \frac{a}{bc} + \frac{b}{ca}$   
 $\Rightarrow \frac{2(b^2+c^2-a^2)}{2bca} + \frac{(a^2+c^2-b^2)}{2acb} + 2\frac{(a^2+b^2-c^2)}{2abc}$   
 $= \frac{a^2+b^2}{abc}$

$\Rightarrow 2(b^2+c^2-a^2) + (a^2+c^2-b^2) + 2(a^2+b^2-c^2) = 2a^2+2b^2$   
 $\Rightarrow -a^2+b^2+c^2 = 0$   
 $\Rightarrow b^2+c^2 = a^2$   
 $\Rightarrow \angle A = 90^\circ$

(b) Given D is mid point of BC

$\Rightarrow BD = DC = a/2$ . Also  $AD \perp AC$  as shown in figure given below

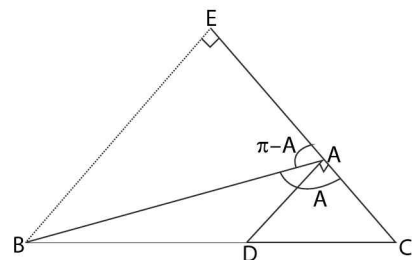

Produce CA and draw perpendicular BE to CA produced. Clearly  $\triangle ADC$  and  $\triangle EBC$  are similar

$$\Rightarrow \frac{CD}{BC} = \frac{CA}{CE} = \frac{AD}{EB} \Rightarrow \frac{1}{2} = \frac{CA}{CE} = \frac{AD}{EB}$$

$$\Rightarrow CE = 2CA \text{ and } EB = 2AD$$

$$\Rightarrow CE = 2b \text{ and } EB = 2(DC^2 - AC^2)^{1/2} = 2 \left( \frac{a^2}{4} - b^2 \right)^{1/2}$$

$$\Rightarrow AE = b, EB = 2\sqrt{\frac{a^2}{4} - b^2}$$

$$\text{Now } \cos(\pi - A) = \frac{AE}{AB}$$

$$\Rightarrow \cos A = \frac{-AE}{AB} = \frac{-b}{c} \dots\dots(i)$$

$$\text{Also } \cos C = \frac{AC}{DC} = \frac{b}{a/2} = \frac{2b}{a} \dots\dots(ii)$$

$$\therefore \text{ From (1) and (2) } \cos A \cdot \cos C = \frac{-2b^2}{ac} \dots\dots(iii)$$

Now in right  $\angle d \triangle ACD$ ,  $CD^2 = AD^2 + AC^2$

$$\Rightarrow \frac{a^2}{4} = AD^2 + b^2 \dots\dots(iv)$$

And in right  $\angle d \triangle EAB$ ,  $AB^2 = AE^2 + BE^2$

$$\Rightarrow c^2 = b^2 + 4AD^2 \dots\dots(v)$$

$$\therefore \text{ From (iv) and (v), we get; } c^2 = b^2 + 4 \left( \frac{a^2}{4} - b^2 \right)$$

$$\Rightarrow c^2 = b^2 + a^2 - 4b^2 \Rightarrow c^2 = a^2 - 3b^2$$

$$\Rightarrow b^2 = \frac{a^2 - c^2}{3} \dots\dots(vi)$$

$$\therefore \text{ From (iii) and (vi), we get; } \cos A \cos C = -\frac{2}{3ac}(a^2 - c^2)$$

$$\Rightarrow \cos A \cdot \cos C = \frac{2(c^2 - a^2)}{3ac} \text{ Hence proved.}$$

$$(c) \frac{\tan A}{1} = \frac{\tan B}{2} = \frac{\tan C}{3} = k(\text{say})$$

In a  $\triangle$ ,  $\tan A + \tan B + \tan C = \tan A \cdot \tan B \cdot \tan C$

$$\Rightarrow 6k = 6k^3 \Rightarrow 6k(k^2 - 1) \Rightarrow k = 0 \text{ or } k = \pm 1$$

But, if  $k = -1$ , then, each of A, B, C would be obtuse angles, so  $k = 1$

$$\Rightarrow \tan A = 1, \tan B = 2, \tan C = 3$$

$$\Rightarrow \sec A = \sqrt{2}, \sec B = \sqrt{5}, \sec C = \sqrt{10}$$

$$\Rightarrow \sin A = 1/\sqrt{2}, \sin B = 2/\sqrt{5}, \sin C = 3/\sqrt{10}$$

$$\Rightarrow \frac{a}{1/\sqrt{2}} = \frac{b}{2/\sqrt{5}} = \frac{c}{3/\sqrt{10}} \text{ (By sine rule)}$$

$$\Rightarrow \sqrt{2}a = \frac{\sqrt{5}b}{2} = \frac{\sqrt{10}c}{3} \Rightarrow 6\sqrt{2}a = 3\sqrt{5}b = 2\sqrt{10}c$$

$$10. \quad c \cos(A - \theta) + a \cos(C + \theta) = c \cos A \cos \theta + c \sin A \sin \theta + a \cos C \cos \theta - a \sin C \sin \theta$$

$$= c \cos \theta \left( \frac{b^2 + c^2 - a^2}{2bc} \right) + \sin \theta (a \sin C) +$$

$$a \cos \theta \left( \frac{a^2 + b^2 - c^2}{2ab} \right) - a \sin C \sin \theta$$

( $\because$  By sine rule,  $a \sin C = c \sin A$ )

$$= \frac{\cos \theta}{2b} (b^2 + c^2 - a^2 + a^2 + b^2 - c^2) = b \cos \theta = \text{L.H.S.}$$

$$11. \quad b \cos^2 C / 2 + c \cos^2 B / 2 = b \left( \frac{1 + \cos C}{2} \right) + c \left( \frac{1 + \cos B}{2} \right)$$

$$= \left( \frac{b+c}{2} \right) + \frac{1}{2} (b \cos C + c \cos B)$$

$$= \frac{b+c}{2} + \frac{1}{2} (a) \text{ (By projection formula)}$$

$$= \frac{1}{2} (a+b+c) = \frac{k}{2}; \text{ where } k = \text{perimeter of } \triangle ABC.$$

$$12. \quad \text{By sine formula, } \frac{a}{1} = \frac{b}{\sin B} = \frac{c}{\sin C} \dots\dots(i)$$

Also  $\sin B, \cos B$  are rationals

$\Rightarrow \tan B$  is rational

$\Rightarrow b/c$  is rational

$\Rightarrow b$  is rational as  $C$  is rational (given)

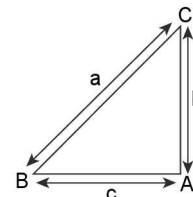

$\therefore$  From (1)  $a = \frac{b}{\sin B} = \frac{\text{rational}}{\text{rational}} = \text{rational}$ . This  $a$  and  $b$  are rational numbers.

$$13. (a) \quad (a+b+c) = 6 \left( \frac{\sin A + \sin B + \sin C}{3} \right) \text{ (Given)}$$

But given  $a = 1$

$$\Rightarrow 1 + b + c = 2 (\sin A + \sin B + \sin C)$$

$$\Rightarrow 1 + \frac{\sin B}{\sin A} + \frac{\sin C}{\sin A} = 2 (\sin A + \sin B + \sin C)$$

( $\because \sin A + \sin B + \sin C > 0$  in a  $\triangle ABC$ )

$$\Rightarrow \frac{1}{\sin A} = 2 \Rightarrow \sin A = \frac{1}{2}$$

$$\Rightarrow A = \frac{\pi}{6} \text{ or } \frac{5\pi}{6}$$

$$(b) \quad \text{Given } B = \frac{\pi}{3}; C = \frac{\pi}{4}$$

$$\Rightarrow A = \frac{5\pi}{12}$$

Given  $BD: DC = 1: 3$

$$\Rightarrow BD = \frac{1}{4}a \text{ and } DC = \frac{3}{4}a$$

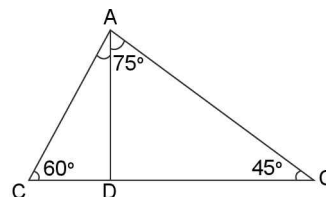

3.84 > Trigonometry

$$\begin{aligned} \therefore \text{ By sine formula, in } \triangle ABD, \frac{AD}{\sin 60^\circ} &= \frac{BD}{\sin \angle BAD} \\ \Rightarrow \frac{AD}{\sqrt{3}/2} &= \frac{a/4}{\sin \angle BAD} \\ \Rightarrow \sin \angle BAD &= \frac{\sqrt{3}}{8} a / AD \quad \dots\dots(i) \end{aligned}$$

$$\begin{aligned} \text{Similarly, in } \triangle ACD, \frac{AD}{\sin 45^\circ} &= \frac{DC}{\sin \angle CAD} \\ \Rightarrow \sin \angle CAD &= \frac{1}{\sqrt{2}} \cdot \frac{3}{4} a / AD \quad \dots\dots(ii) \end{aligned}$$

$$\therefore \frac{\sin \angle BAD}{\sin \angle CAD} = \frac{\sqrt{3}/8}{3/4\sqrt{2}} = \frac{1}{\sqrt{6}} \quad (\text{Dividing (i) by (ii)})$$

(c)  $A > B$ ;  $A, B$  are roots of equation  $3 \sin x - 4 \sin^3 x - k = 0$ ;  $k \in (0, 1)$

$$\begin{aligned} \Rightarrow \sin 3x &= k \in (0, 1) \\ \Rightarrow 3x &= n\pi + (-1)^n \sin^{-1} k; n \in \mathbb{Z} \\ \Rightarrow x &= \frac{n\pi + (-1)^n \sin^{-1} k}{3}; n \in \mathbb{Z} \end{aligned}$$

Since  $A, B$  is angles of  $\triangle ABC$

$$\Rightarrow A, B \in (0, \pi)$$

$$\therefore n = 0$$

$$\Rightarrow x = \frac{\sin^{-1} k}{3} \text{ and } n = 1 \Rightarrow x = \frac{\pi - \sin^{-1} k}{3}$$

Clearly  $k \in (0, 1) \Rightarrow \sin^{-1} k \in (0, \pi/2)$

$$\Rightarrow \frac{\sin^{-1} k}{3} \in \left(0, \frac{\pi}{6}\right) \Rightarrow \frac{-\sin^{-1} k}{3} \in \left(\frac{-\pi}{6}, 0\right)$$

$$\Rightarrow \frac{\pi}{3} - \frac{\sin^{-1} k}{3} \in \left(\frac{\pi}{6}, \frac{\pi}{3}\right)$$

$$\text{So } A = \frac{\pi}{3} - \frac{\sin^{-1} k}{3} \text{ and } B = \frac{\sin^{-1} k}{3} \quad (\because A > B \text{ given})$$

$$\Rightarrow A = \frac{\pi}{3} - B \Rightarrow A + B = \frac{\pi}{3}$$

$$\Rightarrow C = \pi - \frac{\pi}{3} = \frac{2\pi}{3}$$

(d) Given  $BD : DC = 1 : 3$

$$\Rightarrow BD = \frac{1}{4}a \text{ and } DC = \frac{3}{4}a$$

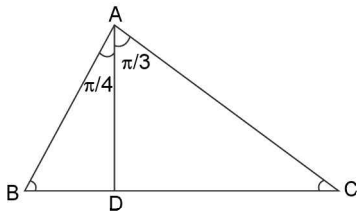

$$\text{By sine formula, in } \triangle ABD, \frac{\sin B}{AD} = \frac{\sin \pi/4}{BD}$$

$$\Rightarrow \sin B = \frac{1}{\sqrt{2}} AD / \frac{1}{4}a$$

$$\text{Similarly } \sin C = \frac{\sqrt{3}}{2} AD / \frac{3}{4}a \Rightarrow \frac{\sin B}{\sin C} = \sqrt{6}$$

14.  $\cot A, \cot B, \cot C$  are in A.P.

$$\begin{aligned} \Rightarrow 2 \cot B &= \cot A + \cot C \\ \Rightarrow 2 \frac{\cos B}{\sin B} &= \frac{\cos A}{\sin A} + \frac{\cos C}{\sin C} \\ \Rightarrow \frac{2 \cos B}{b} &= \frac{\cos A}{a} + \frac{\cos C}{c} \\ \Rightarrow \frac{2}{b} \left( \frac{a^2 + c^2 - b^2}{2ac} \right) &= \frac{1}{a} \left( \frac{b^2 + c^2 - a^2}{2bc} \right) + \frac{1}{c} \left( \frac{a^2 + b^2 - c^2}{2ab} \right) \\ \Rightarrow 2(a^2 + c^2 - b^2) &= b^2 + c^2 - a^2 + a^2 + b^2 - c^2 \\ \Rightarrow 2a^2 + 2c^2 - 2b^2 &= 2b^2 \\ \Rightarrow a^2 + c^2 &= 2b^2 \quad \Rightarrow a^2, b^2, c^2 \text{ are in A.P.} \end{aligned}$$

15. Let  $p, q > 0$  be given positive numbers

$$\therefore a = \frac{p+q}{2}; p, b, c, q \text{ are in G.P.}$$

$$\Rightarrow b = p \left( \frac{q}{p} \right)^{\frac{1}{3}}; c = p \left( \frac{q}{p} \right)^{\frac{2}{3}}$$

$$\begin{aligned} \text{Now, } \frac{\sin^3 B + \sin^3 C}{\sin A \sin B \sin C} &= \frac{b^3 + c^3}{abc} = \frac{p^3 \left( \frac{p}{q} \right) + p^3 \left( \frac{p}{q} \right)^2}{\left( \frac{p+q}{2} \right) p^2 \left( \frac{p}{q} \right)} \\ &= \frac{p + p \left( \frac{q}{p} \right)}{\left( \frac{p+q}{2} \right)} = 2 \end{aligned}$$

16.  $a = mb$  and  $\cos A = \frac{m+1}{2} \sqrt{\frac{1-m^2}{m}}$

$$\text{Now, } \cos A = \left( \frac{m+1}{2} \right) \sqrt{\frac{1-m^2}{m}}$$

$$\Rightarrow \frac{b^2 + c^2 - a^2}{2bc} = \left( \frac{m+1}{2} \right) \sqrt{\frac{1-m^2}{m}}$$

$$\Rightarrow \frac{b^2 + c^2 - m^2 b^2}{2bc} = \left( \frac{m+1}{2} \right) \sqrt{\frac{1-m^2}{m}}$$

$$\Rightarrow b^2(1-m^2) + c^2 = (bc)(m+1) \sqrt{\frac{1-m^2}{m}}$$

$$\Rightarrow c^2 - b(m+1) \sqrt{\frac{1-m^2}{m}} \cdot c + b^2(1-m^2) = 0$$

$$\Rightarrow c_1 + c_2 = b(m+1) \sqrt{\frac{1-m^2}{m}}; c_1 c_2 = b^2(1-m^2)$$

$$(c_1 + c_2)^2 = b^2(m+1)^2 \left( \frac{1-m^2}{m} \right); c_1 c_2 = b^2(1-m)^2$$

$$\Rightarrow \frac{(c_1 + c_2)^2}{c_1 c_2} = \frac{(m+1)^2}{m}$$

$$\Rightarrow \frac{c_1^2 + c_2^2}{c_1 c_2} + 2 = \frac{m^2 + 1}{m} + 2$$

$$\Rightarrow \frac{c_1^2 + c_2^2}{c_1 c_2} = \frac{m^2 + 1}{m}$$

$$\Rightarrow mc_1^2 + mc_2^2 - m^2 c_1 c_2 - c_1 c_2 = 0$$

$$\begin{aligned} &\Rightarrow mc_1(c_1 - mc_2) + c_2(mc_2 - c_1) = 0 \\ &\Rightarrow (mc_1)(c_1 - mc_2) - c_2(c_1 - mc_2) = 0 \\ &\Rightarrow (c_1 - mc_2)(mc_1 - c_2) = 0 \\ &\Rightarrow c_1 = mc_2 \text{ or } c_2 = mc_1 \end{aligned}$$

$$\begin{aligned} 17. \quad \cos \frac{A}{2} &= \frac{1}{2} \left( \frac{b}{c} + \frac{c}{b} \right)^{1/2} \\ &\Rightarrow 2\cos^2 \frac{A}{2} = \frac{b^2 + c^2}{2bc} \\ &\Rightarrow 1 + \cos A = \frac{b^2 + c^2}{2bc} \\ &\Rightarrow 1 + \frac{b^2 + c^2 - a^2}{2bc} = \frac{b^2 + c^2}{2bc} \\ &\Rightarrow 1 - \frac{a^2}{2bc} = 0 \\ &\Rightarrow a^2 = 2bc \quad \Rightarrow \quad \frac{1}{2}a^2 = bc \end{aligned}$$

⇒ Area of the square described with side 'a' as diagonal is equal to the area of rectangle having its two sides equal to other two sides 'b' and 'c'.

### TEXTUAL EXERCISE-1 (OBJECTIVE)

- (b)  $a = 5, b = 7, \sin A = 3/4$   
 $\Rightarrow \cos A = \sqrt{1 - \frac{9}{16}} = \frac{\sqrt{7}}{4}$   
 By cosine formula,  $\cos A = \frac{b^2 + c^2 - a^2}{2bc}$   
 $\Rightarrow \frac{\sqrt{7}}{4} = \frac{49 + c^2 - 25}{2(7)c} \Rightarrow \frac{7\sqrt{7}}{2} = \frac{24 + c^2}{c}$   
 $\Rightarrow 2c^2 + 48 - 7\sqrt{7}c = 0 \Rightarrow \text{Disc.} = 343 - 384 < 0$   
 ⇒ No triangle is possible
- (b) since A, B, C are in A.P.  
 $\Rightarrow 2B = A + C = \pi - B \Rightarrow B = \pi/3$   
 $\Rightarrow \cos B = \frac{1}{2}$   
 $\Rightarrow \frac{a^2 + c^2 - b^2}{2ac} = \frac{1}{2} \Rightarrow a^2 + c^2 - b^2 = ac$   
 $\Rightarrow b^2 = a^2 + c^2 - ac$
- (b)  $\frac{\sin B}{\sin(A+B)} = \frac{\sin B}{\sin C} = \frac{b}{c}$
- (a)  $\frac{\sin(A-B)}{\sin(A+B)} = \frac{\sin(A-B)}{\sin C}$   
 $= \frac{\left[ \frac{a(a^2 + c^2 - b^2)}{2ac} - b \frac{(b^2 + c^2 - a^2)}{2bc} \right]}{c}$   
 $= \frac{1}{2c^2} [a^2 + c^2 - b^2 - b^2 - c^2 + a^2] = \frac{a^2 - b^2}{c^2}$

- (c)  $\because c^2 + a^2 - b^2 = ac$   
 $\Rightarrow \frac{c^2 + a^2 - b^2}{2ac} = \frac{1}{2} \Rightarrow \cos B = \cos \frac{\pi}{3}$   
 $\Rightarrow \angle B = \frac{\pi}{3}$
- (a)  $b^2 \cos 2A - a^2 \cos 2B = b^2(1 - 2\sin^2 A) - a^2(1 - 2\sin^2 B)$   
 $= (b^2 - a^2) + 2[a^2 \sin^2 B - b^2 \sin^2 A] = (b^2 - a^2) + 2(0) = b^2 - a^2$   
 $(\because a \sin B = b \sin A \text{ by sine formula})$
- (a)  $\sum a \sin(B-C) = \sum a(\sin B \cos C - \cos B \sin C)$   
 $= \sum a \left[ kb \left( \frac{a^2 + b^2 - c^2}{2ab} \right) - kc \left( \frac{a^2 + c^2 - b^2}{2ac} \right) \right]$   
 $= \sum \frac{k}{2} (a^2 + b^2 - c^2 - a^2 - c^2 + b^2) = \sum k(b^2 - c^2)$   
 $= k \sum b^2 - k \sum c^2 = 0$
- (c)  $\operatorname{cosec} A (\sin B \cos C + \cos B \sin C)$   
 $\Rightarrow \frac{1}{\sin A} \sin(B+C) = \frac{\sin A}{\sin A} = 1$
- (c)  $a = 3, b = 4, c = 5$   
 $\sin 2B = 2 \sin B \cos B = 2\sqrt{1 - \cos^2 B} \cdot \cos B$   
 Now, as  $\cos B = \frac{a^2 + c^2 - b^2}{2ac} = \frac{9 + 25 - 16}{2(3)(5)} = \frac{3}{5}$   
 $\Rightarrow \sin 2B = 2\sqrt{1 - \frac{9}{25}} \left( \frac{3}{5} \right) = \frac{24}{25}$
- (d)  $\frac{\sin 3B}{\sin B} = \frac{3\sin B - 4\sin^3 B}{\sin B}$   
 $= 3 - 4\sin^2 B = 3 - 4(1 - \cos^2 B)$   
 $= 4\cos^2 B - 1 = 4 \left( \frac{a^2 + c^2 - b^2}{2ac} \right)^2 - 1 = \frac{4}{4} \left( \frac{b^2}{ac} \right)^2 - 1$   
 $= \frac{b^4}{a^2 c^2} - 1 = \frac{1}{4a^2 c^2} (a^2 + c^2)^2 - 1 = \frac{1}{4a^2 c^2} (a^2 - c^2)^2$   
 $= \left( \frac{c^2 - a^2}{2ac} \right)^2$
- (b) Let  $A = k, B = 2k, C = 3k$   
 $\Rightarrow 6k = 180^\circ \Rightarrow k = 30^\circ$   
 $\therefore A = 30^\circ, B = 60^\circ, C = 90^\circ$   
 $\therefore$  By sine formula,  $a : b : c = \sin A : \sin B : \sin C = \frac{1}{2} : \frac{\sqrt{3}}{2} : 1$   
 $= 1 : \sqrt{3} : 2$
- (a, b, c) Since angles A, B, C are in A.P.  
 $\Rightarrow B = 60^\circ$   
 $\therefore$  Let  $A = 60^\circ - d$  and  $C = 60^\circ + d$ ; where d is the common difference of A.P.  
 Now a, b, c are in G.P. Let r be the common ratio  
 $\Rightarrow a = a, b = ar, c = ar^2$

$$\begin{aligned} \therefore \text{ By cosine formula, } \cos B &= \frac{a^2 + c^2 - b^2}{2ac} \\ \Rightarrow \frac{1}{2} &= \frac{a^2 + a^2 r^4 - a^2 r^2}{2a^2 r^2} \Rightarrow r^2 = 1 + r^4 - r^2 \\ \Rightarrow r^4 - 2r^2 + 1 &= 0 \\ \Rightarrow (r^2 - 1)^2 &= 0 \quad \Rightarrow r^2 = 1 \\ \Rightarrow r &= 1 \\ \therefore a &= a, b = a, c = a \\ \Rightarrow a^2, b^2, c^2 &\text{ are in A.P., G.P. as well in H.P.} \end{aligned}$$

13. (c)  $a^2, b^2, c^2$  are in A.P.

$$\begin{aligned} \Rightarrow 2b^2 &= a^2 + c^2 \\ \Rightarrow \cos B &= \frac{b^2}{2ac} \text{ (By cosine formula)} \\ &= \frac{\sin^2 B}{2 \sin A \sin C} \text{ (By sine formula)} \\ \Rightarrow 2 \sin A \sin C \cos B &= \sin^2 B \\ \Rightarrow 2 \cot B &= \frac{\sin B}{\sin A \sin C} = \frac{\sin(A+C)}{\sin A \sin C} \\ \Rightarrow 2 \cot B &= \frac{\sin A \cos C + \cos A \sin C}{\sin A \sin C} \\ \Rightarrow 2 \cot B &= \cot C + \cot A \\ \Rightarrow \cot A, \cot B, \cot C &\text{ are in A.P.} \end{aligned}$$

14. (b)  $\frac{b+c}{11} = \frac{c+a}{12} = \frac{a+b}{13} = \frac{2(a+b+c)}{36}$   
 $= \frac{a+b+c}{18} = k$  (say)

$$\begin{aligned} \Rightarrow a &= 7k; b = 6k; c = 5k \\ \Rightarrow \cos C &= \frac{a^2 + b^2 - c^2}{2ab} = \frac{49 + 36 - 25}{2(7)(6)} = \frac{5}{7} \end{aligned}$$

15. (b)  $b = 20, c = 21$  and  $\sin A = 3/5$

$$\begin{aligned} \Rightarrow \cos A &= 4/5 \quad \Rightarrow \frac{4}{5} = \frac{(20)^2 + (21)^2 - a^2}{2(20)(21)} \\ \Rightarrow a^2 &= 841 - 672 = 169 \Rightarrow a = 13 \end{aligned}$$

16. (a)  $a = 6, b = 10, c = 14$

$$\begin{aligned} \therefore a^2 + b^2 - c^2 &= 36 + 100 - 196 < 0 \\ \Rightarrow \cos C &< 0 \\ \Rightarrow C &\text{ is obtuse angle } \Delta \text{ is obtuse angled } \Delta. \end{aligned}$$

17. (b)  $a \cos B = b \cos A$

$$\begin{aligned} \Rightarrow \sin A \cos B &= \sin B \cos A \quad \text{(Using sine formula)} \\ \Rightarrow \sin A \cos B - \cos A \sin B &= 0 \\ \Rightarrow \sin(A - B) &= 0 \quad \Rightarrow A = B \\ \Rightarrow \Delta &\text{ is an isosceles } \Delta. \end{aligned}$$

18. (c)  $2 \cos A = \sin B \operatorname{cosec} C$

$$\begin{aligned} \Rightarrow 2 \sin C \cos A &= \sin B = \sin(A + C) = \sin A \cos C + \cos A \sin C \\ \Rightarrow \sin C \cos A &= \sin A \cos C \\ \Rightarrow \sin(A - C) &= 0 \quad \Rightarrow A = C \\ \Rightarrow \sin A &= \sin C \quad \Rightarrow a = c \end{aligned}$$

TEXTUAL EXERCISE-2 (SUBJECTIVE)

1. By Napier's analogy,  $\tan\left(\frac{A-B}{2}\right) = \frac{a-b}{a+b} \cot \frac{C}{2}$

$$\Rightarrow \frac{a+b}{a-b} = \cot\left(\frac{A-B}{2}\right) \cdot \cot\left(\frac{\pi}{2} - \left(\frac{A+B}{2}\right)\right)$$

$$\text{Thus } \frac{a+b}{a-b} = \tan\left(\frac{A+B}{2}\right) \cdot \cot\left(\frac{A-B}{2}\right)$$

2. (i)  $\rightarrow$  (ii) i.e., given  $a, b, c$  and area of  $\Delta$  are rational. To prove:  $a, \tan B/2, \tan C/2$  are rational.

$$\tan \frac{B}{2} = \frac{\sqrt{(s-a)(s-c)}}{s(s-b)} = \frac{\Delta}{[s(s-b)]} = \frac{\text{rational}}{\text{rational}} = \text{rational}$$

as,  $a, b, c$  as rationals

$\Rightarrow s, s - b$  are also rationals

$\Rightarrow$  Similarly  $\tan \frac{C}{2}$  is also rational.

(ii)  $\rightarrow$  (iii) i.e., given  $a, \tan \frac{B}{2}, \tan \frac{C}{2}$  are rationals.

$$\Rightarrow \sin B = \frac{2 \tan \frac{B}{2}}{1 + \tan^2 \frac{B}{2}}, \text{ which is rational as } \tan \frac{B}{2} \text{ is rational}$$

$\Rightarrow$  Similarly  $\sin C$  is rational

$$\text{Now, } \tan\left(\frac{A}{2}\right) = \tan\left(\frac{\pi}{2} - \left(\frac{B+C}{2}\right)\right) = \cot\left(\frac{B+C}{2}\right)$$

$$= \frac{1 - \tan \frac{B}{2} \tan \frac{C}{2}}{\tan \frac{B}{2} + \tan \frac{C}{2}}$$

$$\Rightarrow \sin A \text{ is rational as } \sin A = \frac{2 \tan \frac{A}{2}}{1 + \tan^2 \frac{A}{2}}$$

(iii)  $\rightarrow$  (i) i.e., given  $a, \sin A, \sin B, \sin C$  are rational

To prove:  $a, b, c$  and area of  $\Delta$  are rational

$$\text{By sine formula, } \frac{a}{\sin A} = \frac{b}{\sin B} = \frac{c}{\sin C}$$

$$\Rightarrow b = \frac{a \sin B}{\sin A} \text{ and } c = \frac{a \sin C}{\sin A}$$

$\Rightarrow b$  and  $c$  are rational

Now area of  $\Delta = 1/2 bc \sin A$ , which is clearly rational as  $b, c$  and  $\sin A$  are rationals

Thus (iii)  $\rightarrow$  (i)

**Remark:** The above implications conclude that all the above statements are equivalent.

3. (a)  $\cot \frac{A}{2} \cot \frac{B}{2} = c; \cot \frac{B}{2} \cot \frac{C}{2} = a$  and  $\cot \frac{C}{2} \cot \frac{A}{2} = b;$

$$\Rightarrow \sqrt{\frac{s(s-a)}{(s-b)(s-c)}} \times \sqrt{\frac{s(s-b)}{(s-a)(s-c)}} = c$$

$$\Rightarrow \frac{s}{s-c} = c \quad \Rightarrow \frac{1}{s-c} = \frac{c}{s}$$

Similarly  $\frac{1}{s-a} = \frac{a}{s}$  and  $\frac{1}{s-b} = \frac{b}{s}$

$\therefore \frac{1}{s-a} + \frac{1}{s+b} + \frac{1}{s-c} = \frac{1}{s}(a+b+c) = \frac{2s}{s} = 2$

(b)  $a = 18, b = 24, c = 30 \Rightarrow s = 36$

$$\sin A = \frac{2\Delta}{bc} = \frac{2\sqrt{s(s-a)(s-b)(s-c)}}{bc}$$

$$= \frac{2\sqrt{36 \times 18 \times 12 \times 6}}{24 \times 30} = \frac{2 \times 6 \times 6 \times 6}{24 \times 30} = \frac{3}{5}$$

Similarly  $\sin B = \frac{2\Delta}{ac} = \frac{2 \times 6 \times 6 \times 6}{18 \times 30} = \frac{4}{5}$  and

$$\sin C = \frac{2\Delta}{ab} = \frac{2 \times 6 \times 6 \times 6}{18 \times 24} = 1$$

4. Given  $\Delta = a^2 - (b-c)^2$ ;

$\Rightarrow \Delta = [a - (b-c)][a + (b-c)] = (a+c-b)(a+b-c)$   
 $\Rightarrow \Delta = 2(s-b) \cdot 2(s-c) = 4(s-b)(s-c)$  .....(i)

Now  $\Delta = \frac{1}{2}bc \sin A \Rightarrow \sin A = \frac{2\Delta}{bc}$

$= \frac{8(s-b)(s-c)}{bc}$  (using (i))

$\Rightarrow \sin A = 8 \cdot \sin^2 A/2 \left( \text{using } \sin \frac{A}{2} = \frac{\sqrt{(s-b)(s-c)}}{bc} \right)$

$\Rightarrow 2\sin \frac{A}{2} \cos \frac{A}{2} - 8\sin^2 \frac{A}{2} = 0$

$\Rightarrow 2\sin \frac{A}{2} \left( \cos \frac{A}{2} - 4\sin \frac{A}{2} \right) = 0$

$\Rightarrow \sin \frac{A}{2} = 0$  or  $\tan \frac{A}{2} = \frac{1}{4}$

But  $\sin \frac{A}{2} = 0$  is impossible,  $\tan \frac{A}{2} = \frac{1}{4}$

$\therefore \tan A = \frac{2 \tan A/2}{1 - \tan^2 A/2} = \frac{2(1/4)}{1 - \frac{1}{16}} = \frac{1/2}{15/16} = \frac{8}{15}$

5. Given  $3a = b + c \Rightarrow 4a = 2s$

$\Rightarrow s = 2a$  .....(i)

$$\cos \frac{B}{2} \cdot \cot \frac{C}{2} = \sqrt{\frac{s(s-b)}{(s-a)(s-c)} \cdot \frac{s(s-c)}{(s-a)(s-b)}}$$

(Using half angle formula)

$= \frac{S}{s-a} = \frac{2a}{2a-a} = 2$  (using (i))

6.  $\cos \theta = \frac{a}{b+c} \Rightarrow \frac{1 - \tan^2 \theta/2}{1 + \tan^2 \theta/2} = \frac{a}{b+c}$

$\Rightarrow \frac{2}{-2 \tan^2 \theta/2} = \frac{2s}{-2(s-a)}$

$\Rightarrow \tan^2 \frac{\theta}{2} = \frac{s-a}{s}$

Similarly  $\tan^2 \frac{\phi}{2} = \frac{s-b}{s}$  and  $\tan^2 \frac{\psi}{2} = \frac{s-c}{s}$

$\therefore \tan^2 \frac{\theta}{2} + \tan^2 \frac{\phi}{2} + \tan^2 \frac{\psi}{2}$   
 $= \frac{(s-a) + (s-b) + (s-c)}{s} = 1$  .....(i)

In  $\Delta, \frac{\theta}{2} + \frac{\phi}{2} + \frac{\psi}{2} = \frac{\pi}{2}$

$\Rightarrow \frac{\theta}{2} + \frac{\phi}{2} = \frac{\pi}{2} - \frac{\psi}{2}$

$\Rightarrow \tan \left( \frac{\theta}{2} + \frac{\phi}{2} \right) = \cot \frac{\psi}{2}$

$\Rightarrow \sum \tan \frac{\theta}{2} \cdot \tan \frac{\psi}{2} = 1$  .....(ii)

Also  $\left( \tan \frac{\theta}{2} + \tan \frac{\phi}{2} + \tan \frac{\psi}{2} \right)^2$

$= \sum \tan^2 \frac{\theta}{2} + 2 \sum \tan \frac{\theta}{2} \cdot \tan \frac{\psi}{2} = 1 + 2(1) = 3$

$\Rightarrow \tan \frac{\theta}{2} + \tan \frac{\phi}{2} + \tan \frac{\psi}{2} = \sqrt{3}$  .....(iii)

$\left[ \because \frac{\theta}{2}, \frac{\phi}{2}, \frac{\psi}{2} \in \left( 0, \frac{\pi}{2} \right) \right]$

Now,  $\sum \tan^2 \frac{\theta}{2} - \sum \tan \frac{\theta}{2} \cdot \tan \frac{\psi}{2} = 1 - 1 = 0$

$\Rightarrow \frac{1}{2} \left[ \sum \left( \tan \frac{\theta}{2} - \tan \frac{\phi}{2} \right)^2 \right] = 0$

$\Rightarrow \tan \frac{\theta}{2} = \tan \frac{\phi}{2} = \tan \frac{\psi}{2} = \frac{1}{\sqrt{3}}$  ( $\because$  of (iii))

$\Rightarrow \tan \frac{\theta}{2} \cdot \tan \frac{\phi}{2} \cdot \tan \frac{\psi}{2} = \left( \frac{1}{\sqrt{3}} \right)^3 = \frac{1}{3\sqrt{3}}$

7. (a)  $\left( \frac{b-c}{2} \right) \cos^2 \frac{A}{2} + \left( \frac{c-a}{b} \right) \cos^2 \frac{B}{2} + \left( \frac{a-b}{c} \right) \cos^2 \frac{C}{2}$

$= \sum \left( \frac{b-c}{a} \right) \cos^2 \frac{A}{2} = \sum \frac{(b-c) \left[ \frac{s(s-a)}{bc} \right]}$

$= \frac{s}{abc} \sum (b-c) + (s-a) = \frac{s}{abc} \sum \frac{(b-c) + (b+c-a)}{2}$

$= \frac{s}{abc} \sum (b^2 - c^2) + (ac - ab)$

$= \frac{s}{2abc} (\sum b^2 - \sum c^2 + \sum ac - \sum ab) = 0$

(b)  $(b+c-a) \left( \cot \frac{B}{2} + \cot \frac{C}{2} \right)$

$= (b+c-a) \left[ \sqrt{\frac{s(s-b)}{(s-a)(s-c)}} + \sqrt{\frac{s(s-c)}{(s-a)(s-b)}} \right]$

$= 2(s-a) \left[ \frac{\sqrt{s(s-b)} + \sqrt{s(s-c)}}{\sqrt{(s-a)(s-b)(s-c)}} \right] = \frac{2\sqrt{s} \cdot a \sqrt{s-a}}{\sqrt{(s-b)(s-c)}}$

$= 2a \sqrt{\frac{s(s-a)}{(s-b)(s-c)}} = 2a \cot \frac{A}{2}$



3.88 > Trigonometry

8. Given a, 2b, c are in AP

$$\Rightarrow 4b = a + c \quad \Rightarrow 5b = 2s \quad \dots (i)$$

$$\text{Now, } a \cos^2 C/2 + c \cos^2 A/2 = a \left( \frac{s(s-c)}{ab} \right) + c \left( \frac{s(s-a)}{bc} \right)$$

$$= \frac{s(s-c)}{b} + \frac{s(s-a)}{b} = \frac{s}{b} [2s - (a+c)] = \frac{s}{b} [2s - (2s-b)]$$

$$= \frac{s}{b} \times b = \frac{5b}{2} \text{ (using (i))}$$

9. In a  $\Delta$ , the sum of two sides is greater than the third side,  $a + b - c > 0$  etc.

$$\Rightarrow 2(s-c) > 0 \quad \Rightarrow s-c > 0 \text{ etc.}$$

(a) Using A.M  $\geq$  G.M. for  $(s-a)$ ,  $(s-b)$  and  $(s-c)$ , we have  $\frac{(s-a)+(s-b)+(s-c)}{3} \geq \sqrt[3]{(s-a)(s-b)(s-c)}$

$$\Rightarrow \frac{s}{3} \geq \sqrt[3]{(s-a)(s-b)(s-c)}$$

$$\Rightarrow \frac{s^3}{27} \geq (s-a)(s-b)(s-c) \Rightarrow \frac{s^4}{27} \geq A^2$$

$\Rightarrow A \leq \frac{s^2}{3\sqrt{3}}$ ; Here equality holds when  $a = b = c$  i.e.,  $\Delta$  is an equilateral  $\Delta$ .

(b) Using A.M.  $\geq$  G.M. for  $s$ ,  $(s-a)$ ,  $(s-b)$  and  $(s-c)$ , we have

$$\frac{s+(s-a)+(s-b)+(s-c)}{4} \geq \sqrt[4]{s(s-a)(s-b)(s-c)}$$

$$\Rightarrow \frac{s}{2} \geq \sqrt[4]{s(s-a)(s-b)(s-c)}$$

$$\Rightarrow \frac{s^4}{16} \geq A^2 \Rightarrow A \leq \frac{s^2}{4}$$

Here equality holds when  $S = (s-a) = (s-b) = (s-c)$ .

$\Rightarrow a = b = c = 0$ . Which is never possible.

$$\therefore A \neq \frac{s^2}{4} \Rightarrow A < \frac{s^2}{4}$$

10. Given: a, b, c are in H.P.

$$\Rightarrow \frac{1}{a}, \frac{1}{b}, \frac{1}{c} \text{ are in A.P. and } b = \frac{2ac}{a+c} \quad \dots (i)$$

Now  $\sin^2 \frac{A}{2}, \sin^2 \frac{B}{2}, \sin^2 \frac{C}{2}$  will be in H.P.

$$\text{iff } \sin^2 \frac{B}{2} = \frac{2 \sin^2 \frac{A}{2} \cdot \sin^2 \frac{C}{2}}{\sin^2 \frac{A}{2} + \sin^2 \frac{C}{2}}$$

$$\Rightarrow \frac{(s-a)(s-c)}{ac} = \frac{\frac{2(s-b)(s-c)}{bc} \cdot \frac{(s-a)(s-b)}{ab}}{\frac{(s-b)(s-c)}{bc} + \frac{(s-a)(s-b)}{ab}}$$

$$\Rightarrow \frac{(s-a)(s-c)}{ac} = \frac{2(s-a)(s-b)^2(s-c)}{ab^2c} \times \frac{abc}{(s-b)[a(s-c)+c(s-a)]}$$

$$\Rightarrow \frac{b}{2ac} = \frac{(s-b)}{[a(s-c)+c(s-a)]} = \frac{b}{2ac} = \frac{(s-b)}{[s(a+c)-2ac]}$$

$$\Rightarrow \frac{1}{(a+c)} = \frac{(s-b)}{[s(a+c)-2ac]} = \frac{s - \left( \frac{2ac}{a+c} \right)}{[s(a+c)-2ac]}$$

(using (i))

$$\Rightarrow \frac{1}{a+c} = \frac{1}{(a+c)}, \text{ which is true}$$

11.  $\tan \frac{A}{2} = \frac{5}{36}; \tan \frac{B}{2} = \frac{12}{5}$

$$\Rightarrow \sqrt{\frac{(s-b)(s-c)}{s(s-a)}} = \frac{5}{36} \quad \dots (i)$$

$$\Rightarrow \sqrt{\frac{(s-a)(s-c)}{s(s-b)}} = \frac{12}{5} \quad \dots (ii)$$

From equation (i)  $\times$  (ii), we get

$$\sqrt{\frac{(s-b)(s-c)}{s(s-a)} \times \frac{(s-a)(s-c)}{s(s-b)}} = \frac{5}{36} \times \frac{12}{5} = \frac{1}{3}$$

$$\Rightarrow \frac{s-c}{s} = \frac{1}{3}$$

$$\Rightarrow 3s - 3c = s$$

$$\Rightarrow 2s = 3c$$

$$\Rightarrow a + b + c = 3c$$

$$\Rightarrow a + b = 2c$$

$$\Rightarrow a, c, b \text{ are in A.P.}$$

12.  $\Delta = \frac{ap_1}{2} = \frac{bp_2}{2} = \frac{cp_3}{2}$

$$\Rightarrow \frac{1}{p_1} + \frac{1}{p_2} + \frac{1}{p_3} = \frac{a}{2\Delta} + \frac{b}{2\Delta} + \frac{c}{2\Delta}$$

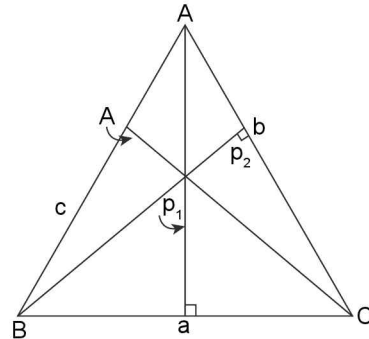

$$= \frac{2(s-c)}{2\Delta} = \frac{s-c}{\Delta} = \frac{2s(s-c)}{(a+b+c)\Delta}$$

$$= \frac{2ab}{(a+b+c)} \cdot \left( \frac{s(s-c)}{ab} \right) = \frac{2ab}{(a+b+c)\Delta} \cos^2 \frac{C}{2}$$

13. Clearly PL and PM being medians intersect each other at centroid G. Further PL = 6 cm

$$\Rightarrow PG = \frac{2}{3} PL = \frac{2}{3}(6) = 4 \text{ cm. and } GL = \frac{1}{3}(6) = 2 \text{ cm}$$

$$\therefore \text{In } \Delta PQG, \tan \frac{\pi}{6} = \frac{QG}{PG}$$

$$\Rightarrow QG = PG \frac{\pi}{6} = \frac{4}{\sqrt{3}}$$

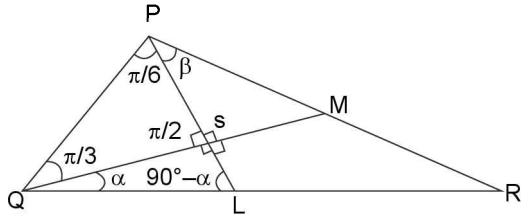

∴ Area of  $\Delta PQR = 2ar \Delta PQL$   
 $= 2\left(\frac{1}{2}PL \times QL\right) = 6 \times \frac{4}{\sqrt{3}} = 8\sqrt{3} \text{ cm}^2$   
 Alternatively area of  $\Delta PQR = 3ar \Delta PQR = 3$   
 $\left(\frac{1}{2}PG \times QG\right) = \frac{3}{2} \times 4 \times \frac{4}{\sqrt{3}} = 8\sqrt{3} \text{ cm}^2$

14. L.H.S. =  $a \sin A + b \sin B + c \sin C = k(a^2 + b^2 + c^2)$ ;

$\left(\because \frac{a}{\sin A} = \frac{b}{\sin B} = \frac{c}{\sin C} = \frac{1}{k}\right)$

R.H.S. =  $\sqrt{a^2 + b^2 + c^2} = \sqrt{\sin^2 A + \sin^2 B + \sin^2 C}$   
 $= \sqrt{a^2 + b^2 + c^2} \sqrt{a^2 k^2 + b^2 k^2 + c^2 k^2} = k(a^2 + b^2 + c^2)$

∴ L.H.S. = R.H.S.

15. L.H.S. =  $a \sin\left(\frac{A}{2} + B\right) = a \sin\left(\frac{A+2B}{2}\right)$   
 $= a \sin\left(\frac{A+B+B}{2}\right) = a \sin\left(\frac{\pi - C + B}{2}\right)$   
 $= a \sin\left(\frac{\pi}{2} - \left(\frac{C-B}{2}\right)\right) = a \cos\left(\frac{C-B}{2}\right)$   
 $= a \left[\cos \frac{C}{2} \cos \frac{B}{2} + \sin \frac{C}{2} \sin \frac{B}{2}\right]$   
 $= a \left[\sqrt{\frac{s(s-a)s(s-b)}{ab \cdot ac}} + \sqrt{\frac{(s-a)(s-b)(s-a)(s-s)}{ab \cdot ac}}\right]$   
 $= (s + s - a) \sqrt{\frac{(s-b)(s-c)}{bc}} = (b+c) \sin \frac{A}{2}$

16. (i) By m - n theorem,  $(1+2) \cot \theta = 2 \cot 45^\circ - 1 \cot 60^\circ$

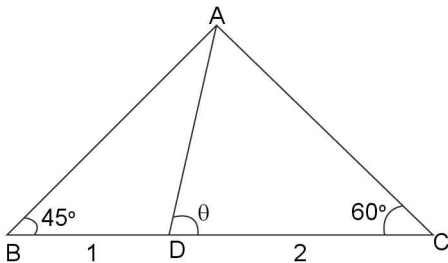

$\Rightarrow \cot \theta = \frac{2 - \frac{1}{\sqrt{3}}}{3} = \frac{2\sqrt{3} - 1}{3\sqrt{3}}$

(ii) ∴ BD : DC = mk : nk = m : n

By m-n theorem,  $(m+n) \cot 120^\circ = n \cot 60^\circ - m \cot 30^\circ$

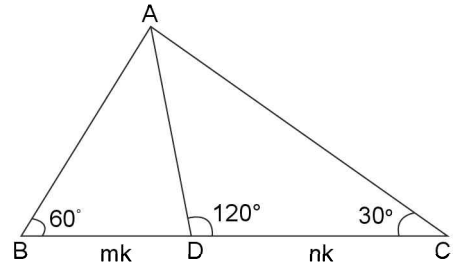

$\Rightarrow (m+n) (-\cot 60^\circ) = n \left(\frac{1}{\sqrt{3}}\right) - m(\sqrt{3})$

$\Rightarrow (m+n) \left(-\frac{1}{\sqrt{3}}\right) = \frac{n-3m}{\sqrt{3}}$

$\Rightarrow m+n = 3m-n \Rightarrow m=n$

$\Rightarrow m : n = 1 : 1$  (lowest form)

$\Rightarrow (m+n) = 2$

17.  $\alpha = \tan^{-1}\left(\frac{3}{5}\right)$ ;  $CL = 40m$

By m - n theorem,  $(LB + AB) = LB \cot B - AB \cot \alpha$

$\Rightarrow h = \frac{h}{4} \cot \beta - \frac{3}{4}h \left(\frac{5}{3}\right)$

$\Rightarrow \frac{5}{4}h + h = \frac{h}{4} \cot \beta \Rightarrow \frac{9}{4}h = \frac{h}{4} \cot \beta$

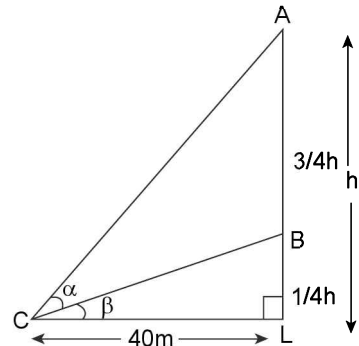

$\Rightarrow \cot \beta = 9 \Rightarrow \frac{40}{h/4} = 9 \Rightarrow h = \left(\frac{160}{9}\right)m$

18.  $\angle A = 60^\circ, b = 3, c = 2\sqrt{3}$

Since AD is angle bisector of  $\angle A$

$\Rightarrow \alpha = \beta = 30^\circ$

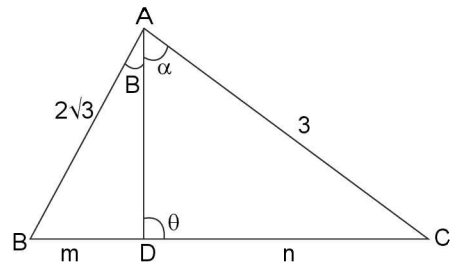

3.90 > Trigonometry

By angle bisector theorem,  $m : n = 2\sqrt{3} : 3 = 2 : \sqrt{3}$

$$\begin{aligned} \therefore \text{By } m-n \text{ theorem } (2 + \sqrt{3}) \cot \theta &= 2 \cot \beta - \sqrt{3} \cot \alpha = \\ &= 2 \cot 30^\circ - \sqrt{3} \cot 30^\circ = 2\sqrt{3} - \sqrt{3} \cdot \sqrt{3} \\ \Rightarrow \cot \theta &= \frac{2\sqrt{3} - 3}{2 + \sqrt{3}} \Rightarrow \theta = \cot^{-1} \left( \frac{2\sqrt{3} - 3}{2 + \sqrt{3}} \right) \end{aligned}$$

$$\begin{aligned} \Rightarrow \text{Further length at angle bisector is given by } &\frac{2bc}{b+c} \cos \frac{A}{2} \\ &= \frac{2(3)2(\sqrt{3})}{3+2\sqrt{3}} \cos 30^\circ = \frac{12\sqrt{3}}{\sqrt{3}(2+\sqrt{3})} \cdot \frac{\sqrt{3}}{2} = \frac{6\sqrt{3}}{2+\sqrt{3}} \text{ units} \end{aligned}$$

19. Area of  $\Delta ABC = \frac{1}{2} bc \sin 30^\circ = \frac{1}{4} bc = \frac{\sqrt{3}}{4} a^2$  (given)

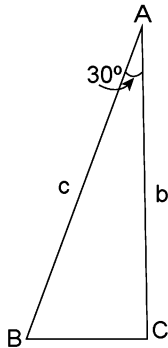

$$\Rightarrow bc = \sqrt{3} a^2 \Rightarrow \sin B \sin C = \sqrt{3} \sin^2 A$$

$$\Rightarrow \sin B \sin C = \sqrt{3} \cdot \frac{1}{4} \Rightarrow 2 \sin B \sin C = \frac{\sqrt{3}}{2}$$

$$\Rightarrow \cos(B - C) - \cos(B + C) = \sqrt{\frac{3}{2}}$$

$$\Rightarrow \cos(B - C) + \frac{\sqrt{3}}{2} = \frac{\sqrt{3}}{2}$$

$$\Rightarrow \cos(B - C) = 0 \Rightarrow B - C = \pm \pi/2$$

$$\Rightarrow B - C = \pi/2 \text{ or } C - B = \pi/2$$

$$\text{But } B + C = 5\pi/6$$

$$\Rightarrow B = 2\pi/3 \text{ or } C = 2\pi/3$$

$$\Rightarrow \text{When } B = 2\pi/3, C = \pi/6 \text{ and when } C = 2\pi/3, B = \pi/6$$

$$\Rightarrow C = 4B \text{ or } B = 4C$$

20.  $PM = \frac{\sqrt{7+5\sqrt{3}}}{13}$ ;  $QR = ?$

By m - n theorem,  $2 \cot \theta = \cot 45^\circ - \cot 30^\circ$

$$\Rightarrow 2 \cot \theta = 1 - \sqrt{3}$$

$$\Rightarrow \cot \theta = \frac{1 - \sqrt{3}}{2} \Rightarrow \sin \theta = \frac{\sqrt{2}}{\sqrt{4 - \sqrt{3}}}$$

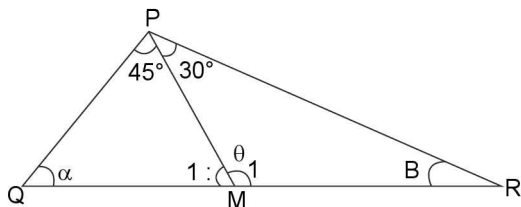

In  $\Delta PMR$ , by sine formula,  $\frac{MR}{\sin 30^\circ} = \frac{PM}{\sin \beta} \Rightarrow 2MR = \frac{PM}{\sin \beta}$

$$\Rightarrow QR = \frac{PM}{\sin B} = \frac{PM}{\sin[180^\circ - (\theta + 30^\circ)]} = \frac{PM}{\sin(\theta + 30^\circ)} \quad (\because 2MR = QM)$$

$$= \frac{PM}{\sin \theta \cdot \frac{\sqrt{3}}{2} + \cos \theta \cdot \frac{1}{2}} = \frac{2(PM)}{(\sqrt{3} \sin \theta + \cos \theta)}$$

$$\begin{aligned} &= \frac{2(PM)}{\sin \theta \cdot (\sqrt{3} + \cos \theta)} = \frac{2(PM)}{\sqrt{4 - \sqrt{3}} \left( \sqrt{3} + \frac{1 - \sqrt{3}}{2} \right)} \\ &= \frac{2(PM)}{\sqrt{\frac{2}{4 - \sqrt{3}} \times \frac{\sqrt{3} + 1}{2}}} = \frac{2(PM)}{\sqrt{\frac{\sqrt{3} + 1}{4 - \sqrt{3}}}} = \frac{2(PM)}{\sqrt{(\sqrt{3} + 1)(4 + \sqrt{3})}} \end{aligned}$$

$$= \frac{2(PM)}{\sqrt{\frac{7 + 5\sqrt{3}}{13}}} = \frac{2 \left( \sqrt{\frac{7 + 5\sqrt{3}}{13}} \right)}{\left( \sqrt{\frac{7 + 5\sqrt{3}}{13}} \right)} = 2$$

21. Let  $a$  and  $b$  be two sides of  $\Delta ABC$ , given by roots of quadratic equation  $x^2 - 2\sqrt{3}x + 2 = 0$

$$\Rightarrow a, b = \frac{2\sqrt{3} \pm \sqrt{12 - 8}}{2} = \sqrt{3} \pm 1$$

Let  $a = \sqrt{3} + 1$  and  $b = \sqrt{3} - 1$  angle between sides ' $a$ ' and ' $b$ ' is  $\pi/3$ .

$$\Rightarrow \angle C = \pi/3$$

$$\therefore \text{By cosine formula, } \cos C = \frac{a^2 + b^2 - c^2}{2ab}$$

$$\Rightarrow \frac{1}{2} = \frac{8 - c^2}{2(2)} \Rightarrow c = \sqrt{6}$$

$$\therefore \text{Perimeter of } \Delta = a + b + c = 2\sqrt{3} + \sqrt{6}$$

TEXTUAL EXERCISE-2 (OBJECTIVE)

1 (a)  $(s - a)(s - b)$ ,

$$\tan \frac{C}{2} = \sqrt{\frac{(s - a)(s - b)}{s(s - c)}} = \sqrt{1} = 1$$

$$\Rightarrow C = 90^\circ$$

2. (a)  $2S = a + b + c$ ;  $(s - b)(s - c) = x \sin^2 A/2$ ;  $x = ?$

$$\sin^2 \frac{A}{2} = \frac{(s - b)(s - c)}{bc} \Rightarrow x = bc$$

3. (c)  $\Sigma(b + c) \cos A = (b + c) \cos A + (c + a) \cos B + (a + b) \cos C$   
 $= (b \cos A + a \cos B) + (c \cos A + a \cos C) + (c \cos B + b \cos C)$   
 $= (c + b + a)$  (By using projection formula)

4. (a)  $a = 16$ ,  $b = 24$ ,  $c = 20$

$$2 \cos^2 \frac{B}{2} = 1 + \cos B = 1 + \left( \frac{a^2 + c^2 - b^2}{2ac} \right)$$

$$= 1 + \left[ \frac{256 + 400 - 576}{2(16)(20)} \right] = 1 + \frac{80}{2 \times 16 \times 20} \Rightarrow \cos \frac{B}{2} = \frac{3}{4}$$

$$\begin{aligned}
 5. \text{ (a)} \quad 1 - \tan \frac{A}{2} \tan \frac{B}{2} &= 1 - \sqrt{\frac{(s-b)(s-c)}{s(s-a)}} \times \frac{(s-a)(s-c)}{s(s-b)} \\
 &= 1 - \frac{s-c}{s} = \frac{c}{s} = \frac{2c}{a+b+c}
 \end{aligned}$$

$$\begin{aligned}
 6. \text{ (d)} \quad \tan \frac{A}{2}, \tan \frac{C}{2} &= \frac{1}{2} = \frac{s-b}{s} = \frac{1}{2} \\
 \Rightarrow 2s - 2b &= s \quad \Rightarrow a + b + c = 4b \\
 \Rightarrow a, b, c &\text{ are non of A.P., G.P. and H.P.}
 \end{aligned}$$

$$\begin{aligned}
 7. \text{ (b)} \quad \frac{\sin \frac{A}{2} \sin \frac{C}{2}}{\sin \frac{B}{2}} &= \sqrt{\frac{(s-b)(s-c)}{bc} \cdot \frac{(s-a)(s-b)}{ab}} \\
 &= \sqrt{\frac{(s-a)(s-b)^2(s-c)}{ab^2c}} \times \frac{ac}{(s-a)(s-c)} \\
 &= \frac{s-b}{b} = \frac{a+c-b}{2b} \\
 &= \frac{2b-b}{2b} = \frac{b}{2b} = \frac{1}{2}
 \end{aligned}$$

$$\begin{aligned}
 8. \text{ (c)} \quad \tan \left( \frac{B-C}{2} \right) &= x \cot \frac{A}{2} \\
 \Rightarrow x &= \frac{b-c}{b+c} \quad (\text{By Napier's Analogy})
 \end{aligned}$$

$$\begin{aligned}
 9. \text{ (a)} \quad a \cos^2 \frac{C}{2} + c \cos^2 \frac{A}{2} &= \frac{3b}{2} \\
 \Rightarrow a \left( \frac{s(s-c)}{ab} \right) + c \left( \frac{s(s-a)}{bc} \right) &= \frac{3b}{2} \\
 \Rightarrow \frac{s(s-c)}{b} + \frac{s(s-a)}{b} &= \frac{3b}{2} \\
 \Rightarrow \frac{s}{b} [2s - (a+c)] &= \frac{3b}{2} \\
 \Rightarrow \frac{s}{b} [b] &= \frac{3b}{2} \quad \Rightarrow 2s = 3b \\
 \Rightarrow a + b + c &= 3b \quad \Rightarrow a + c = 2b \\
 \Rightarrow a, b, c &\text{ are in A.P.}
 \end{aligned}$$

$$\begin{aligned}
 10. \text{ (b)} \quad \text{By Napier's analogy, } \tan \left( \frac{A-B}{2} \right) &= \frac{a-b}{a+b} \cot \frac{C}{2} = \\
 \frac{a-b}{a+b} \cot \left( \frac{\pi}{2} - \left( \frac{A+B}{2} \right) \right) &= \frac{a-b}{a+b} \tan \left( \frac{A+B}{2} \right) \\
 \Rightarrow \cot \left( \frac{A+B}{2} \right) \cdot \tan \left( \frac{A-B}{2} \right) &= \frac{a-b}{a+b}
 \end{aligned}$$

$$\begin{aligned}
 11. \text{ (b)} \quad A = 30^\circ, b = 2, c = \sqrt{3} + 1, \frac{C-B}{2} &= ? \\
 \tan \left( \frac{C-B}{2} \right) &= \frac{c-b}{c+b} \cot \frac{A}{2} = \frac{\sqrt{3}-1}{\sqrt{3}+3} \cot 15^\circ \\
 &= \frac{\sqrt{3}-1}{\sqrt{3}(\sqrt{3}+1)} \cot(45^\circ - 30^\circ)
 \end{aligned}$$

$$\begin{aligned}
 &= \frac{\sqrt{3}-1}{\sqrt{3}(\sqrt{3}+1)} \left[ \frac{\cot 30^\circ + 1}{\cot 30^\circ - 1} \right] = \frac{\sqrt{3}-1}{\sqrt{3}(\sqrt{3}+1)} \left[ \frac{\sqrt{3}+1}{\sqrt{3}-1} \right] = \frac{1}{\sqrt{3}} \\
 \Rightarrow \frac{C-B}{2} &= \frac{\pi}{6} = 30^\circ
 \end{aligned}$$

$$\begin{aligned}
 12. \text{ (b)} \quad \frac{\tan \frac{A}{2} - \tan \frac{B}{2}}{\tan \frac{A}{2} + \tan \frac{B}{2}} &= \frac{\sin \left( \frac{A-B}{2} \right)}{\sin \left( \frac{A+B}{2} \right)} \\
 &= \frac{\sin \left( \frac{A-B}{2} \right) \sin \left( \frac{A+B}{2} \right)}{\sin^2 \left( \frac{A+B}{2} \right)} = \frac{\sin^2 \frac{A}{2} - \sin^2 \frac{B}{2}}{\cos^2 \frac{C}{2}} \\
 &= \frac{(s-b)(s-c) - (s-a)(s-c)}{bc} \cdot \frac{ac}{s(s-c)} \\
 &= \frac{(s-c) \left[ \frac{a(s-b) - b(s-a)}{ab} \right]}{c} \times \frac{ab}{s(s-c)} = \frac{a-b}{c}
 \end{aligned}$$

$$\begin{aligned}
 13. \text{ (b)} \quad 2ac \sin \left( \frac{A-B+C}{2} \right) &= 2ac \sin \left[ \frac{\pi}{2} - B \right] = 2ac \cos B \\
 &= 2ac \left[ \frac{a^2 + c^2 - b^2}{2ac} \right] = a^2 + c^2 - b^2
 \end{aligned}$$

$$14. \text{ (b)} \quad \frac{s(s-a)}{bc} - \frac{(s-b)(s-c)}{bc} = \cos^2 \frac{A}{2} - \sin^2 \frac{A}{2} = \cos A$$

$$\begin{aligned}
 15. \text{ (a)} \quad \frac{c+b}{c-b} \tan \frac{A}{2} &= \cot \left( \frac{C-B}{2} \right) \cot \frac{A}{2} \tan \frac{A}{2} \\
 &\quad (\text{By Napier's Analogy}) \\
 &= \cot \left( \frac{C-B}{2} \right) = \cot \left( \frac{\pi}{2} - \left( \frac{A+B}{2} \right) - \frac{B}{2} \right) \\
 &= \cot \left[ \frac{\pi}{2} - B - \frac{A}{2} \right] = \tan \left( \frac{A}{2} + B \right)
 \end{aligned}$$

$$16. \text{ (a)} \quad \cot \frac{A-B}{2} \cdot \cot \frac{C}{2} = \frac{a+b}{a-b} \tan \frac{C}{2} \cdot \cot \frac{C}{2} = \frac{a+b}{a-b}$$

$$\begin{aligned}
 17. \text{ (a)} \quad \text{Here } \cos A = \frac{c}{b} \Rightarrow \tan^2 \frac{A}{2} &= \frac{1 - \cos A}{1 + \cos A} \\
 &= \frac{1 - c/b}{1 + c/b} = \frac{b-c}{b+c}
 \end{aligned}$$

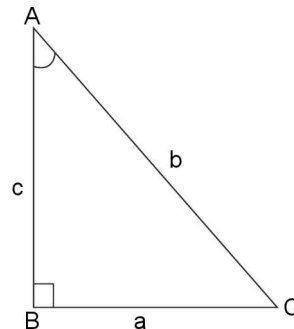

3.92 > Trigonometry

18. (b)  $a = (\sqrt{3} + 1)$ ;  $\angle B = 30^\circ$ ,  $\angle C = 45^\circ$   
 $\Rightarrow \angle A = 180^\circ - 75^\circ = 105^\circ$   
 By sine formula,  $\frac{a}{\sin A} = \frac{b}{\sin B} = \frac{c}{\sin 45^\circ}$   
 $\Rightarrow \frac{\sqrt{3} + 1}{\sin 105^\circ} = \frac{b}{\sin 30^\circ} = \frac{c}{\sin 45^\circ}$   
 $\Rightarrow b = \frac{(\sqrt{3} + 1)\sin 30^\circ}{\sin 105^\circ} = \frac{(\sqrt{3} + 1)}{2\sin(45^\circ + 60^\circ)} = \sqrt{2}$   
 $\therefore$  Area of  $\Delta = \frac{1}{2}ab \sin C = \frac{1}{2}(\sqrt{3} + 1)(\sqrt{2})\frac{1}{\sqrt{2}}$   
 $= \frac{\sqrt{3} + 1}{2} \text{ cm}^2$

19. (c) Area of  $\Delta ABC = \Delta$ , Now,  $a^2 \sin 2B + b^2 \sin 2A = 2a^2 \sin B \cos B + 2b^2 \sin A \cos A$   
 $= \frac{2a^2b}{2R} \cos B + \frac{2b^2a}{2R} \cos A$   
 $= \frac{a^2b}{R} \left( \frac{a^2 + c^2 - b^2}{2ac} \right) + \frac{b^2a}{R} \left( \frac{b^2 + c^2 - a^2}{2bc} \right)$   
 $= \frac{ab}{2cR} (a^2 + c^2 - b^2) + \frac{ab}{cR} (b^2 + c^2 - a^2)$   
 $= \frac{a}{2cR} (ba^2 + bc^2 - b^3 + bc^2 - ba^2)$   
 $= \frac{a}{2cR} (2bc^2) = \frac{abc}{R} = 4\Delta$

20. (d) Let  $\frac{\cos A}{a} = \frac{\cos B}{b} = \frac{\cos C}{c} = k$  (say) (given) and  
 $\frac{\sin A}{a} = \frac{\sin B}{b} = \frac{\sin C}{c} = k'$  (say) (by sine formula)  
 $\Rightarrow \frac{1}{a} = \frac{k}{\cos A} = \frac{k'}{\sin A} \Rightarrow \tan A = \frac{k'}{k}$   
 Similarly  $\tan B = \frac{k'}{k}$  and  $\tan C = \frac{k'}{k}$   
 $\Rightarrow \tan A = \tan B = \tan C$   
 $\Rightarrow A = B = C = \frac{\pi}{3}$   
 $\Rightarrow$  Area of  $\Delta ABC = \frac{\sqrt{3}}{4}(a^2) = \sqrt{3}$  ( $\because a = 2$  given)

21. (d)  $c^2 = a^2 + b^2$ ,  $2s = a + b + c$ ,  $4s(s - a)(s - b)(s - c) = 4\Delta^2 = 4 [1/2ab]^2 = a^2b^2$   
 $(\because c^2 = a^2 + b^2 \Rightarrow \Delta$  is right  $\angle d \Delta \Rightarrow$  area of  $\Delta = 1/2 ab)$

22. (c)  $\Delta = \frac{1}{2}ab \sin C = \frac{1}{2}ab \left( \frac{c}{2R} \right) = \frac{abc}{4R}$  (By sine formula)  
 $\Rightarrow R = \frac{abc}{4\Delta}$

23. (c) By sine formula  $\frac{a}{2\sin \theta} = \frac{x}{\sin B} = \frac{c}{\sin \alpha}$  ... (i)  
 and  $\frac{a}{2\sin(A - \theta)} = \frac{x}{\sin C} = \frac{b}{\sin \alpha}$  ... (ii)

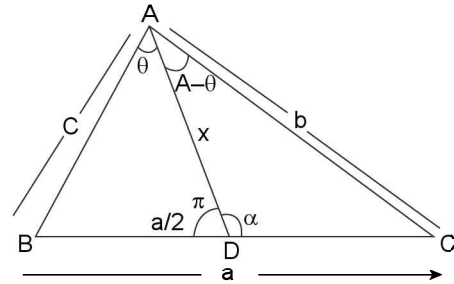

From (i)  $a \sin \alpha = (\sin \theta)(2c)$  and from (ii)  $a \sin \alpha = [\sin(A - \theta)](2b)$   
 $\Rightarrow \sin(A - \theta) = c/b (\sin \theta)$

24. (a) In  $\Delta ABD$ ,  $\pi - \theta = \pi - \left( B - \frac{A}{2} \right)$   
 $\Rightarrow \sin \theta = \sin \left( B + \frac{A}{2} \right)$

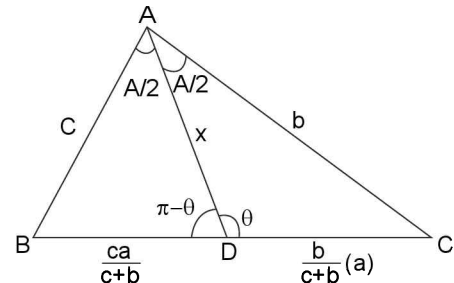

$= \sin \left( B + \frac{\pi}{2} - \left( \frac{B+C}{2} \right) \right) = \sin \left( \frac{\pi}{2} + \frac{B-C}{2} \right) = \cos \left( \frac{B-C}{2} \right)$

TEXTUAL EXERCISE-3 (SUBJECTIVE)

1. (a) (i)  $\angle A = 105^\circ$ ,  $\angle C = 60^\circ$ ,  $b = 4$ ; clearly  $\angle B = 15^\circ$

By sine formula,  $\frac{a}{\sin 105^\circ} = \frac{4}{\sin 15^\circ} = \frac{c}{\sin 60^\circ}$

$\Rightarrow a = \frac{4 \sin 105^\circ}{\sin 15^\circ} = 4 \cot 15^\circ = 4(2 + \sqrt{3})$

and  $c = \frac{4 \sin 60^\circ}{\sin 15^\circ} = 2\sqrt{6}(\sqrt{3} + 1)$

(ii)  $\angle C = 60^\circ$ ,  $b = 4$ ,  $c = 4\sqrt{3}$

By, sine formula  $\frac{a}{\sin A} = \frac{b}{\sin B} = \frac{c}{\sin C}$

$\Rightarrow \frac{a}{\sin A} = \frac{4}{\sin B} = \frac{4\sqrt{3}}{\sqrt{3}/2} = 8$

$\Rightarrow \sin B = 1/2$

$\Rightarrow \angle B = 30^\circ$  and hence  $\angle A = 90^\circ$

$\Rightarrow a = 8$ ;  $\sin 90^\circ = 8$

(iii)  $a = 2$ ,  $b = 4$ ,  $\angle C = 60^\circ$

By cosine formula,  $\frac{1}{2}$

$= \frac{4 + 16 - c^2}{2(2 \times 4)} \Rightarrow c^2 = 12 \Rightarrow c = 2\sqrt{3}$

$$\therefore \text{By sine formula, } \frac{2}{\sin A} = \frac{4}{\sin B} = \frac{2\sqrt{3}}{\sqrt{3}/2} = 4$$

$$\Rightarrow \sin A = 1/2; \sin B = 1$$

$$\Rightarrow A = \pi/6; B = \pi/2$$

$$(b) a = \sqrt{3}, b = \sqrt{2} \text{ and } c = \frac{\sqrt{6} + \sqrt{2}}{2}$$

$$\cos A = \frac{b^2 + c^2 - a^2}{2bc} = \frac{2 + \left(\frac{8 + 2\sqrt{12}}{4}\right) - 3}{2\left(\frac{\sqrt{6} + \sqrt{2}}{\sqrt{2}}\right)}$$

$$= \frac{2 + (2 + \sqrt{3}) - 3}{\sqrt{12} + 2} = \frac{1 + \sqrt{3}}{2(1 + \sqrt{3})} = \frac{1}{2}$$

$$\Rightarrow A = \pi/3$$

$$\text{Now by sine formula, } \frac{\sqrt{3}}{\sqrt{3}/2} = \frac{\sqrt{2}}{\sin B} = \frac{\sqrt{6} + \sqrt{2}}{\sin C}$$

$$\Rightarrow \sin B = 1/\sqrt{2} \quad \Rightarrow B = \pi/4$$

$$\Rightarrow C = 5\pi/12$$

$$(c) \angle A = 60^\circ, a = 5, b = 2\sqrt{3}, \angle B = ?$$

$$\text{By sine formula, } \frac{a}{\sin A} = \frac{b}{\sin B} = \frac{c}{\sin C}$$

$$\Rightarrow \frac{5}{\sin 60^\circ} = \frac{2\sqrt{3}}{\sin B} \quad \Rightarrow \sin B = \frac{2\sqrt{3}}{5} \times \frac{\sqrt{3}}{2} = \frac{3}{5}$$

$$\Rightarrow B = \sin^{-1}\left(\frac{3}{5}\right) \text{ or } 180^\circ - \sin^{-1}\frac{3}{5} \text{ (obtuse angle)}$$

$$\text{But } a = 5, b = 2\sqrt{3} \quad \Rightarrow a > b$$

$$\Rightarrow \angle A > \angle B$$

$$\Rightarrow \angle B \text{ must be acute } \therefore \angle B = \sin^{-1}\frac{3}{5}$$

$$2. a = 2b \text{ and } |A - B| = \pi/3, \angle C = ?$$

$$\text{By Napier's analogy, } \tan\left(\frac{A-B}{2}\right) = \left(\frac{a-b}{a+b}\right) \cot \frac{C}{2}$$

$$\Rightarrow \tan\left(\pm \frac{\pi}{6}\right) = \frac{b}{3b} \cot \frac{C}{2} \Rightarrow \pm \sqrt{3} = \cot \frac{C}{2}$$

$$\Rightarrow \frac{C}{2} = \frac{\pi}{6} \text{ or } \frac{5\pi}{6} \quad \Rightarrow C = \frac{\pi}{3} \text{ or } \frac{5\pi}{3} \text{ (impossible)}$$

$$\Rightarrow C = \pi/3$$

$$3. \cos 3A + \cos 3B + \cos 3C = 1$$

$$\Rightarrow 2 \cos \left[ \frac{3(A+B)}{2} \right] \cos \left[ \frac{3(A-B)}{2} \right] + \cos 3C = 1$$

$$\Rightarrow 2 \cos \left[ 3 \left[ \frac{\pi}{2} - \frac{C}{2} \right] \right] \cos \left[ 3 \left( \frac{A-B}{2} \right) \right] + \cos 3C = 1$$

$$\Rightarrow -2 \sin \left[ \frac{3C}{2} \right] \cos \left( 3 \left( \frac{A-B}{2} \right) \right) + \cos 3C = 1$$

$$\Rightarrow -2 \sin \frac{3C}{2} \cos \left( \frac{3A-3B}{2} \right) - 2 \sin^2 \frac{3C}{2} = 0$$

$$\Rightarrow \left( 2 \sin \frac{3C}{2} \right) \left[ \cos \left( \frac{3A-3B}{2} \right) + \sin \left( \frac{3C}{2} \right) \right] = 0$$

$$\Rightarrow \left( 2 \sin \frac{3C}{2} \right) \left[ \cos \left( \frac{3A-3B}{2} \right) + \sin \left( \frac{3\pi}{2} - \left( \frac{3A+3B}{2} \right) \right) \right] = 0$$

$$\Rightarrow 2 \sin \frac{3C}{2} \cdot 2 \sin \frac{3A}{2} \sin \frac{3B}{2} = 0$$

$$\Rightarrow \text{At least one of } A, B \text{ or } C \text{ is } 2\pi/3 \left( \because \frac{3A}{2} = \pi \Rightarrow A = \frac{2\pi}{3} \right)$$

$$\therefore \text{Obtuse angle is } \frac{2\pi}{3} = 120^\circ$$

$$4. \sin(2A + B) = \sin(C - A) = -\sin(B + 2C) = 1/2; A, B, C \text{ are in A.P.}$$

$$\therefore A, B, C \text{ are in A.P. } \Rightarrow \angle B = \pi/3$$

$$\therefore \sin(2A + \pi/3) = \sin(C - A) = -\sin\left(\frac{\pi}{3} + 2C\right) = \frac{1}{2}$$

$$\Rightarrow \text{Also } C + A = 2\pi/3 \quad \dots\dots(i)$$

$$\text{And } (C - A) \in (-\pi, \pi) \text{ and } \sin(C - A) = 1/2$$

$$\Rightarrow C - A = \pi/6 \text{ or } 5\pi/6 \quad \dots\dots(ii)$$

$$\therefore \text{from (i) and (ii), } C = \frac{5\pi}{12} \text{ or } C = \frac{3\pi}{4} \text{ (Impossible as } \angle A$$

$$\text{becomes } -15^\circ)$$

$$\Rightarrow \angle A = \pi/4, \angle B = \pi/3, \angle C = 5\pi/12$$

$$\text{i.e., } \angle A = 45^\circ, \angle B = 60^\circ, \angle C = 75^\circ$$

$$5. \angle A = 45^\circ; \angle C = 60^\circ$$

$$\text{To prove: } a + c\sqrt{2} = 2b. \text{ Clearly } \angle B = 75^\circ$$

$$\Rightarrow a = k \sin A; b = k \sin B; c = k \sin C$$

$$\Rightarrow a = k \cdot 1/\sqrt{2}; b = k \left[ \frac{1}{\sqrt{2}}, \frac{\sqrt{3}}{2} + \frac{1}{\sqrt{2}} \cdot \frac{1}{2} \right]; c = k \cdot \frac{\sqrt{3}}{2}$$

$$\therefore a + c\sqrt{2} = k \left[ \frac{1}{\sqrt{2}} + \frac{\sqrt{3}}{2} \right] = \frac{k(\sqrt{3} + 1)}{\sqrt{2}}$$

$$\text{and } 2b = \frac{k(\sqrt{3} + 1)}{\sqrt{2}}$$

$$\therefore a + c\sqrt{2} = 2b$$

$$6. a = 3, b = 8 \sin A = 5/13$$

$$\therefore \cos A = \frac{b^2 + c^2 - a^2}{2bc}$$

$$\Rightarrow C^2 - (2b \cos A)c + (b^2 - a^2) = 0$$

$$\Rightarrow C = \frac{2b \cos A \pm \sqrt{4b^2 \cos^2 A - 4(b^2 - a^2)}}{2}$$

$$\Rightarrow C = b \cos A \pm \sqrt{b^2 \cos^2 A - b^2 + a^2}$$

$$\Rightarrow C = b \cos A \pm \sqrt{a^2 - b^2 \sin^2 A}$$

$$\text{Now } a^2 - b^2 \sin^2 A = 9 - 64 \left( \frac{25}{169} \right) = \frac{1521 - 1600}{169} < 0$$

$$\Rightarrow C \text{ has imaginary values}$$

$$\Rightarrow \text{No triangle is possible}$$

$$7. \text{ Given: } D \text{ is mid point of } AC; \angle C = \pi/2$$

$$\text{To find: } \cot \angle DBC = \cot \theta = ?$$

3.94 > Trigonometry

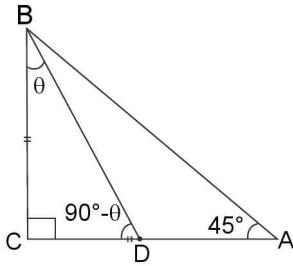

By m-n theorem,  $(1 + 1) \cot(90^\circ - \theta) = 1 \cot 45^\circ - 1 \cot 90^\circ$   
 $\Rightarrow 2 \tan \theta = 1 \quad \Rightarrow \cot \theta = 2$

8.  $a^4 + b^4 + c^4 = 2c^2(a^2 + b^2)$  ... (i)

$$\cos C = \frac{a^2 + b^2 - c^2}{2ab}$$

$$\Rightarrow \cos^2 C = \frac{a^4 + b^4 + c^4 + 2a^2b^2 - 2b^2c^2 - 2a^2c^2}{4a^2b^2}$$

$$= \frac{2a^2c^2 + 2b^2c^2 + 2a^2b^2 - 2b^2c^2 - 2a^2c^2}{4a^2b^2} \quad (\text{using (i)})$$

$$\Rightarrow \cos C = \pm \frac{1}{\sqrt{2}} \Rightarrow C = \frac{\pi}{4} \text{ or } \frac{3\pi}{4}$$

9.  $a = 5, b = 4 \cos(A - B) = \frac{31}{32}, C = ?$

$$\cos(A - B) = \frac{1 - \tan^2\left(\frac{A - B}{2}\right)}{1 + \tan^2\left(\frac{A - B}{2}\right)} = \frac{31}{32}$$

$$\Rightarrow \frac{-2\tan^2\left(\frac{A - B}{2}\right)}{2} = \frac{-1}{63} \Rightarrow \tan^2\left(\frac{A - B}{2}\right) = \frac{1}{63}$$

$$\Rightarrow \tan\left(\frac{A - B}{2}\right) = \pm \frac{1}{3\sqrt{7}}; \text{ But } \cos(A - B) = \frac{31}{32}$$

$$\Rightarrow A - B \text{ is acute} \Rightarrow \tan\left(\frac{A - B}{2}\right) = \frac{1}{3\sqrt{7}}$$

$$\therefore \text{ By Napier's analogy, } \frac{a - b}{a + b} \cot \frac{C}{2} = \frac{1}{3\sqrt{7}}$$

$$\Rightarrow \frac{1}{9} \cot \frac{C}{2} = \frac{1}{3\sqrt{7}} \Rightarrow \cot \frac{C}{2} = \frac{3}{\sqrt{7}} \Rightarrow \cos \frac{C}{2} = \frac{3}{4}$$

$$\Rightarrow \cos C = 2\left(\frac{3}{4}\right)^2 - 1 = \frac{1}{8}$$

$$\Rightarrow \frac{1}{8} = \frac{25 + 16 - C^2}{48} \Rightarrow C^2 = 36 \Rightarrow C = 6$$

10.  $\tan \frac{A}{2} = \frac{5}{6}; \tan \frac{B}{2} = \frac{20}{27}$

$$\text{In a } \triangle ABC, \tan \frac{C}{2} = \tan \left[ \frac{\pi}{2} - \left( \frac{A}{2} + \frac{B}{2} \right) \right]$$

$$= \cot \left( \frac{A}{2} + \frac{B}{2} \right) = \frac{1 - \tan \frac{A}{2} \cdot \tan \frac{B}{2}}{\tan \frac{A}{2} + \tan \frac{B}{2}} = \frac{1 - \frac{5}{6} \times \frac{20}{27}}{\frac{5}{6} + \frac{20}{27}} = \frac{2}{5}$$

$\therefore \frac{A}{2}, \frac{B}{2}, \frac{C}{2} \in (0, \pi/2)$  and  $\tan \theta$  is increasing function

function in  $(0, \pi/2)$  and  $\frac{5}{6} > \frac{28}{37} > \frac{2}{5}$

$$\Rightarrow \tan \frac{A}{2} > \tan \frac{B}{2} > \tan \frac{C}{2}$$

$$\Rightarrow A > B > C \quad \Rightarrow a > b > c$$

11. 
$$\frac{(a + b + c)(b + c - a)(c + a - b)(a + b - c)}{4b^2c^2}$$

$$= \frac{(2s)(2s - 2a)(2s - 2b)(2s - 2c)}{4b^2c^2} = \frac{4\Delta^2}{b^2c^2}$$

$$= \left( \frac{a^2b^2c^2}{4b^2c^2R^2} \right) = \frac{a^2}{4R^2} = \left( \frac{a}{2R} \right)^2 \quad \left( \because \Delta = \frac{abc}{4R} \right)$$

$$= \sin^2 A \quad (\text{By sine formula})$$

TEXTUAL EXERCISE-3 (OBJECTIVE)

1. (d)  $AB = 2BC \Rightarrow c = 2a$

$$\text{By Napier's analogy, } \tan \left( \frac{C - A}{2} \right) = \frac{c - a}{c + a} \cot \frac{B}{2}$$

$$\Rightarrow \frac{\tan \frac{B}{2}}{\cot \left( \frac{C - A}{2} \right)} = \frac{a}{3a} = \frac{1}{3}$$

2. (c) Let  $\angle A = 3x, \angle B = 5x, \angle C = 4x$

$$\Rightarrow 12x = 180^\circ \Rightarrow x = 15^\circ$$

$$\Rightarrow \angle A = 45^\circ, \angle B = 76^\circ, \angle C = 60^\circ$$

$$\therefore \text{ By sine formula, } \frac{a}{1/\sqrt{2}} = \frac{b}{\left[ \frac{\sqrt{3} + 1}{2\sqrt{2}} \right]} = \frac{c}{\sqrt{3}/2}$$

$$\Rightarrow \sqrt{2}a = \frac{2\sqrt{2}b}{\sqrt{3} + 1} = \frac{2c}{\sqrt{3}} = k(\text{say})$$

$$\Rightarrow a = \frac{k}{\sqrt{2}}, b = \frac{(\sqrt{3} + 1)k}{2\sqrt{2}}, c = \frac{\sqrt{3}k}{2}$$

$$\therefore (a + b + \sqrt{2}) = k \left[ \frac{1}{\sqrt{2}} + \frac{(\sqrt{3} + 1)}{2\sqrt{2}} + \frac{\sqrt{3}}{\sqrt{2}} \right]$$

$$= \frac{k}{2\sqrt{2}} [2 + \sqrt{3} + 1 + 2\sqrt{3}]$$

$$= \frac{k}{2\sqrt{2}} [3 + 3\sqrt{3}] = \frac{k^3}{2\sqrt{2}} [1 + \sqrt{3}] = 3b$$

3. (a) Let  $\angle A = 4x, \angle B = x, \angle C = x$

$$\Rightarrow 6x = 180^\circ \Rightarrow x = 30^\circ$$

$$\Rightarrow \angle A = 120^\circ, \angle B = 30^\circ, \angle C = 30^\circ$$

$$\therefore \text{ By sine formula } a = k \frac{\sqrt{3}}{2}, b = \frac{k}{2}, c = \frac{k}{2}$$

$$\therefore \text{ Longest side: Perimeter} = \frac{\sqrt{3}/2}{\left( \frac{\sqrt{3}}{2} + 1 \right)} = \frac{\sqrt{3}}{\sqrt{3} + 2}$$

4. (b) Clearly  $\angle A = 90^\circ$ ,  $\angle B = 30^\circ$ ,  $\angle C = 60^\circ$

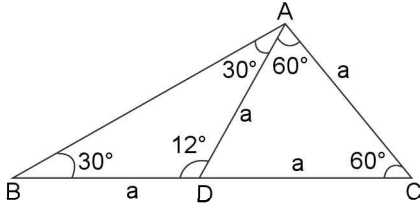

$\therefore$  By sine formula,  $a^2 : b^2 : c^2 = 1 : \frac{1}{4} : \frac{3}{4} = 4 : 1 : 3$

5. (c)  $\frac{a^2 - b^2}{a^2 + b^2} = \frac{\sin(A-B)}{\sin(A+B)}$ . Using componendo and divi-

dendo.

$$\begin{aligned} \frac{2a^2}{-2b^2} &= \frac{2\sin A \cos B}{-2\cos A \sin B} \Rightarrow \frac{a^2}{b^2} = \frac{\sin A \cos B}{\cos A \sin B} \\ \Rightarrow \frac{a}{b} &= \frac{\cos B}{\cos A} \Rightarrow \frac{\sin A}{\sin B} = \frac{\cos B}{\cos A} \Rightarrow \sin 2A = \sin 2B \\ \Rightarrow 2A &= n\pi + (-1)^n 2B; n \in \mathbb{Z} \\ \Rightarrow 2A &= 2B \text{ or } 2A + 2B = \pi \Rightarrow \\ \Delta &\text{ is isosceles or right angled} \end{aligned}$$

(Note: It is interesting to notice that option (a), (b) (c) and (d) are false as their negations does not imply the negation of given statement ( $p \Rightarrow q \Leftrightarrow \sim q \Rightarrow \sim p$ ))

6. (a)  $b, c$  and  $\sin B, \angle B$  is acute,  $b < c \sin B$ ;  $\cos B = \frac{a^2 + c^2 - b^2}{2ac}$

$$\begin{aligned} \Rightarrow a^2 - (2c \cos B)a + (c^2 - b^2) &= 0 \\ \Rightarrow \text{Disc.} &= 4c^2 \cos^2 B - 4(c^2 - b^2) = 4(b^2 - c \sin^2 B) < 0 \text{ as } \\ &b < c \sin B \\ \Rightarrow a &\text{ is imaginarily} \Rightarrow \text{No triangle is possible} \end{aligned}$$

7. (c) Sides are  $3x + 4y$ ,  $4x + 3y$  and  $5x + 5y$  units,  $x, y > 0$

$$a^2 = (3x + 4y)^2 = 9x^2 + 16y^2 + 24xy$$

$$b^2 = (4x + 3y)^2 = 16x^2 + 9y^2 + 24xy$$

$$c^2 = (5x + 5y)^2 = 25x^2 + 25y^2 + 50xy$$

$$\therefore a^2 + b^2 - c = -2xy < 0 \text{ as } x > 0, y > 0$$

$$\Rightarrow \cos C < 0 \Rightarrow C \text{ must be obtuse angle}$$

8. (b)  $\cos A = \frac{b^2 + c^2 - a^2}{2bc}$

$$\Rightarrow b^2 - (2c \cos A)b + (c^2 - a^2) = 0$$

Its roots are  $b_1, b_2$

$$\Rightarrow b_1 + b_2 = 2c \cos A; b_1 b_2 = (c^2 - a^2)$$

$$\text{Also given } b_2 = 2b_1 \Rightarrow b_1 = \frac{2c \cos A}{3}; 2b_1^2 = c^2 - a^2$$

$$\Rightarrow 2 \left( \frac{4c^2 \cos^2 A}{9} \right) = c^2 - a^2$$

$$\Rightarrow \cos^2 A = \frac{9(c^2 - a^2)}{8c^2}$$

$$\Rightarrow \sin A = \sqrt{1 - \frac{9(c^2 - a^2)}{8c^2}} = \sqrt{\frac{9a^2 - c^2}{8c^2}}$$

9. (a)  $\because a, b, c$  are in A.P.

$$\Rightarrow 2b = a + c \Rightarrow 2\sin B = \sin A + \sin C$$

$$\Rightarrow 4 \sin \frac{B}{2} \cos \frac{B}{2} = 2 \sin \left( \frac{A+C}{2} \right) \cos \left( \frac{A-C}{2} \right)$$

$$= 2 \cos \frac{B}{2} \cos \left( \frac{A-C}{2} \right)$$

$$\Rightarrow 2 \sin \frac{B}{2} = \cos \left( \frac{A-C}{2} \right) \Rightarrow \sin \frac{B}{2}$$

$$= \cos \left( \frac{A-C}{2} \right) - \cos \left( \frac{A+C}{2} \right)$$

$$\Rightarrow \sin \frac{B}{2} = 2 \sin \frac{A}{2} \sin \frac{C}{2} \quad \dots (i)$$

Now  $\cos A + 2\cos B + \cos C = (\cos A + \cos C) + \cos B + \cos B$

$$= 2 \cos \frac{A+C}{2} \cos \frac{A-C}{2} + \left( 1 - 2\sin^2 \frac{B}{2} \right) + \cos B$$

$$= 2 \sin \frac{B}{2} \cos \frac{A-C}{2} - \sin^2 \frac{B}{2} + \cos B + 1$$

$$= 2 \sin \frac{B}{2} \left[ \cos \left( \frac{A-C}{2} \right) - \cos \left( \frac{A+C}{2} \right) \right] + \cos B + 1$$

$$= 4 \sin \frac{A}{2} \sin \frac{B}{2} \sin \frac{C}{2} + \cos B + 1 \text{ (using (i))}$$

$$= 2 \sin^2 \frac{B}{2} + 2 \cos^2 \frac{B}{2} = 2$$

10. (a)  $\angle B = 90^\circ \Rightarrow A + C = \pi/2 \Rightarrow \frac{A}{2} + \frac{C}{2} = \frac{\pi}{4}$

$$\Rightarrow \frac{\tan \frac{A}{2} + \tan \frac{C}{2}}{1 - \tan \frac{A}{2} \tan \frac{C}{2}} = 1 \quad \dots (i)$$

Now, by Napier's analogy,  $\tan \left( \frac{B-C}{2} \right) = \frac{b-c}{b+c} \cot \frac{A}{2}$

$$\Rightarrow \frac{b-c}{b+c} = \tan \frac{A}{2} \tan \left( \frac{B-C}{2} \right) = \tan \frac{A}{2} \left[ \frac{\tan \frac{B}{2} - \tan \frac{C}{2}}{1 + \tan \frac{B}{2} \tan \frac{C}{2}} \right]$$

$$= \tan \frac{A}{2} \left[ \frac{1 - \tan \frac{C}{2}}{1 + \tan \frac{C}{2}} \right] \quad (\because B/2 = \pi/4)$$

$$= \tan \frac{A}{2} \cdot \frac{\tan \frac{A}{2} (1 + \tan \frac{C}{2})}{(1 + \tan \frac{C}{2})} \text{ (By using (i))}$$

$$= \tan^2 A/2 \Rightarrow \sqrt{\frac{b-c}{b+c}} = \tan \frac{A}{2}$$

11. (b)  $a = 5, b = 7, \sin A = \frac{3}{4}, b \sin A = \frac{21}{4} > a$

$$\Rightarrow a < b \sin A$$

$\Rightarrow$  No triangle is possible



**3.96** ➤ Trigonometry

- 12. (c)**  $a = 13$  cm,  $b = 12$  cm,  $c = 5$  cm  
Clearly  $\Delta$  is right angled  $\Delta$  with  $\angle A = 90^\circ$   
 $\Rightarrow \frac{1}{2}h(BC) = \frac{1}{2}cb \Rightarrow \frac{1}{2}h(13) = \frac{1}{2}(5)(12)$   
 $\Rightarrow h = \frac{60}{13}$
- 13. (b)** Let  $a = n - 1$ ,  $b = n$ ,  $c = n + 1$ ;  $n \in \mathbb{N}$  and  $n \geq 2$   
 $\therefore$  Largest angle = C and smallest angle = A  
 A.T.Q,  $C = 2A$   
 $\sin C = \sin 2A$   
 $\Rightarrow \sin C = 2 \sin A \cos A$   
 $\Rightarrow \frac{c}{2a} = \cos A \Rightarrow \frac{b^2 + c^2 - a^2}{2bc} = \frac{c}{2a}$   
 $\Rightarrow \frac{(n^2)(n+1)^2 - (n-1)^2}{(n)(n+1)} = \frac{n+1}{2(n-1)}$   
 $\Rightarrow n = 5 \Rightarrow a = 4, b = 5, c = 6$

- 14. (d)**  $\sin A + \sin B + \sin C = 1 + \sqrt{2}$  ... (i)  
 $\cos A + \cos B + \cos C = \sqrt{2}$  ... (ii)  
 From (i),  $4 \cos \frac{A}{2} \cos \frac{B}{2} \cos \frac{C}{2} = 1 + \sqrt{2}$  ... (iii)  
 From (ii)  $4 \sin \frac{A}{2} \sin \frac{B}{2} \sin \frac{C}{2} + 1 = \sqrt{2}$   
 $\Rightarrow 4 \sin \frac{A}{2} \sin \frac{B}{2} \sin \frac{C}{2} = \sqrt{2} - 1$  ... (iv)  
 (iii)  $\times$  (iv) gives,  $2 \sin A \sin B \sin C = 1$   
 $\Rightarrow \sin A \sin B \sin C = 1/2$   
 Obviously the above equation is invalid for equilateral  $\Delta$ 's as well as for general isosceles  $\Delta$ . e.g., if  $\angle A = 30^\circ$ ,  $\angle B = 30^\circ$ ,  $\angle C = 120^\circ$ , the  $\sin A \cdot \sin B \cdot \sin C = \frac{\sqrt{3}}{8} \neq \frac{1}{2}$ .  
 Also it is not valid for right angled  $\Delta$ , e.g., if  $\angle A = 90^\circ$ ,  $\angle B = 60^\circ$ ,  $\angle C = 30^\circ$ , the  $\sin A \cdot \sin B \cdot \sin C = \frac{\sqrt{3}}{4} \neq \frac{1}{2}$ .  
 But it is true for right angled isosceles  $\Delta$ .

- 15. (b)**  $2 \cos A \sin C = \sin B \Rightarrow 2 \cos A = \frac{b}{c}$   
 $\Rightarrow \frac{b^2 + c^2 - a^2}{bc} = \frac{b}{c}$   
 $\Rightarrow c^2 = a^2 \Rightarrow \Delta$  is isosceles
- 16. (a)**  $\cos B \cdot \cos C + \sin B \sin C \cdot \sin^2 A = 1$   
 $\Rightarrow \cos B \cos C + \sin B \sin C (1 - \cos^2 A) = 1$   
 $\Rightarrow \cos B \cos C + \sin B \sin C = 1 + \sin B \sin C \cos^2 A$   
 $\Rightarrow \cos(B - C) = 1 + \sin B \sin C \cos^2 A$  ... (i)  
 Clearly for a  $\Delta$ , R.H.S  $\geq 1$ , but L.H.S  $\leq 1$   
 $\Rightarrow$  (i) must hold when both sides are equal to 1  
 $\Rightarrow B = C$  and  $A = \pi/2$   
 $\Rightarrow \Delta$  is isosceles right angled.
- 17. (c)**  $\sqrt{3} \cos \theta + \sin \theta = k, |k| < 2$   
 $\Rightarrow 2 \sin \left( \theta + \frac{\pi}{3} \right) = k$

$$\Rightarrow \sin \left( \theta + \frac{\pi}{3} \right) = \frac{k}{2} \in (-1, 1) \dots \dots (i)$$

Now A and B are two different values of  $\theta$  satisfying (i)

$$\Rightarrow \sin \left( A + \frac{\pi}{3} \right) = \sin \left( B + \frac{\pi}{3} \right) = \frac{k}{2}$$

$$\Rightarrow \sin \left( A + \frac{\pi}{3} \right) = \sin \left( B + \frac{\pi}{3} \right)$$

$$\Rightarrow A + \frac{\pi}{3} = n\pi + (-1)^n \left( B + \frac{\pi}{3} \right)$$

$$\Rightarrow A + \frac{\pi}{3} = B + \frac{\pi}{3} \text{ at } n = 0 \text{ or } A + \frac{\pi}{3} = \pi - B - \frac{\pi}{3} \text{ at } n = 1$$

$$\Rightarrow A = B \text{ or } A + B = \pi/3. \text{ But } A \text{ and } B \text{ are different.}$$

$$\Rightarrow A + B = \pi/3 \Rightarrow C = 2\pi/3$$

$$\Rightarrow \Delta \text{ is obtuse angled.}$$

**18. (b)**  $\frac{\cos^2 \frac{A}{2}}{a} + \frac{\cos^2 \frac{B}{2}}{b} + \frac{\cos^2 \frac{C}{2}}{c}$   
 $= \frac{(1 + \cos A)}{2a} + \frac{(1 + \cos B)}{2b} + \frac{1 + \cos C}{2c}$   
 $= \frac{1}{2} \left( \frac{1}{a} + \frac{1}{b} + \frac{1}{c} \right) + \frac{1}{2} \left[ \frac{\cos A}{a} + \frac{\cos B}{b} + \frac{\cos C}{c} \right]$   
 $= \frac{1}{2} \left( \frac{bc + ac + ab}{abc} \right) + \frac{1}{2} \left[ \frac{b^2 + c^2 - a^2 + a^2 + c^2 - b^2 + a^2 + b^2 - c^2}{2abc} \right]$   
 $= \frac{(a + b + c)^2}{4abc} = \frac{4s^2}{4abc} = \frac{s^2}{abc}$

**TEXTUAL EXERCISE-4 (SUBJECTIVE)**

- 1.**  $a = 13, b = 4, \cos C = -5/13$   
 By cosine formula,  $\cos C = \frac{a^2 + b^2 - c^2}{2ab}$   
 $\Rightarrow \frac{-5}{13} = \frac{169 + 16 - c^2}{2(13)(4)}$   
 $\Rightarrow -40 = 185 - c^2$   
 $\Rightarrow c^2 = 225$   
 $\Rightarrow c = 15$   
 Now  $\sin C = \sqrt{1 - \frac{25}{109}} = \frac{12}{13}$   
 $\therefore \Delta = \frac{1}{2} ab \sin C = \frac{1}{2} (13)(4) \left( \frac{12}{13} \right) = 24$  s units  
 Now  $R = \frac{abc}{4\Delta} = \frac{(13)(4)(15)}{4(24)} = \frac{65}{8}$   
 $r = \frac{\Delta}{s} = \frac{24 \times 2}{a + b + c} = \frac{48}{13 + 4 + 15} = \frac{3}{2}$   
 $r_1 = \frac{\Delta}{s - a} = \frac{2\Delta}{(b + c - a)} = \frac{48}{4 + 15 - 13} = 8$

$$r_2 = \frac{\Delta}{s-b} = \frac{2\Delta}{a+c-b} = \frac{48}{13+15-4} = 2$$

$$r_3 = \frac{\Delta}{s-c} = \frac{2\Delta}{a+b-c} = \frac{48}{13+4-15} = 24$$

$$2. \text{ (a) } r_1 r_2 r_3 = \frac{\Delta}{s} \cdot \frac{\Delta}{s-a} \cdot \frac{\Delta}{s-b} \cdot \frac{\Delta}{s-c} = \frac{\Delta^4}{\Delta^2} = \Delta^2$$

$$\text{(b) } r_1 r_2 + r_2 r_3 + r_3 r_1$$

$$= \frac{\Delta^2}{(s-a)(s-b)} + \frac{\Delta^2}{(s-b)(s-c)} + \frac{\Delta^2}{(s-c)(s-a)}$$

$$= \left[ \frac{(s-c) + (s-a) + (s-b)}{(s-a)(s-b)(s-c)} \right] \Delta^2 = \frac{s\Delta^2}{\Delta^2/s} = s^2$$

$$\text{(c) } (r_1 - r)(r_2 - r)(r_3 - r) = \pi \left( \frac{\Delta}{(s-a)} - \frac{\Delta}{s} \right)$$

$$= \pi \Delta \left[ \frac{a}{s(s-a)} \right] = \frac{abc\Delta^3}{s^3(s-a)(s-b)(s-c)}$$

$$= \frac{(4R\Delta)(\Delta^3)}{s^2\Delta^2} = \frac{4R\Delta^2}{s^2} = 4Rr^2$$

$$\text{(d) } \Delta = 2R^2 \sin A \cdot \sin B \cdot \sin C$$

$$\text{R.H.S.} = 2R^2 \sin A \cdot \sin B \cdot \sin C$$

$$= 2R^2 \left( \frac{a}{2R} \right) \left( \frac{b}{2R} \right) \left( \frac{c}{2R} \right) = \frac{abc}{4R} = \Delta$$

$$\text{(e) } \frac{1}{bc} + \frac{1}{ca} + \frac{1}{ab} = \frac{a+b+c}{abc} = \frac{2s}{abc}$$

$$= 2 \left( \frac{\Delta}{r} \right) \cdot \frac{1}{abc} = \frac{2}{r(abc)} \cdot \frac{abc}{4R} = \frac{1}{2Rr}$$

$$\text{(f) } \left( \begin{array}{l} \because r_1 = s \tan \frac{A}{2}, r_2 = s \tan \frac{B}{2}, r_3 = s \tan \frac{C}{2}, \\ r = (s-a) \tan \frac{A}{2} = (s-b) \tan \frac{B}{2} = (s-c) \tan \frac{C}{2} \end{array} \right)$$

$$\text{And R.H.S.} = \tan^2 \frac{A}{2} = \frac{(s-b)(s-c)}{s(s-a)} = \frac{\frac{r}{\tan \frac{B}{2}} \cdot \frac{r}{\tan \frac{C}{2}}}{\frac{r}{\tan \frac{A}{2}} \cdot \left( \frac{r}{\tan \frac{A}{2}} \right)}$$

$$= \frac{r}{r_3} \cdot \frac{\tan A/2}{\tan B/2} = \frac{r}{r_3} \cdot \frac{r_1/s}{r_2/s} = \frac{r r_1}{r_2 r_3} = \text{L.H.S.}$$

$$\text{(g) } r^3 \cot^2 A/2 \cdot \cot^2 B/2 \cdot \cot^2 C/2 = r_1 r_2 r_3$$

$$\text{From last part (f)}$$

$$\cot^2 A/2 = \frac{r_2 r_3}{r r_1}, \cot^2 B/2 = \frac{r_1 r_3}{r r_2}, \cot^2 C/2 = \frac{r_1 r_2}{r r_3}$$

$$\Rightarrow \cot^2 \frac{A}{2} \cdot \cot^2 \frac{B}{2} \cdot \cot^2 \frac{C}{2} = \frac{r_1^2 r_2^2 r_3^2}{r^3 \cdot r_1 r_2 r_3} = \frac{r_1 r_2 r_3}{r^3}$$

$$\Rightarrow r^3 \cot^2 \frac{A}{2} \cdot \cot^2 \frac{B}{2} \cdot \cot^2 \frac{C}{2} = r_1 r_2 r_3$$

$$\text{(h) } r r_1 \cot A/2 = \Delta$$

$$\text{or } r r_1 = \Delta \tan \frac{A}{2} \text{ or } r_1 = \frac{\Delta}{r} \tan \frac{A}{2}$$

$$\text{or } r_1 s = \tan \frac{A}{2} \text{ which is standard result.}$$

$$3. \text{ (a) (i) } \frac{1}{r_1} + \frac{1}{r_2} + \frac{1}{r_3} = \frac{1}{r}, \text{ L.H.S.} = \frac{1}{r_1} + \frac{1}{r_2} + \frac{1}{r_3}$$

$$= \frac{s-a}{\Delta} + \frac{s-b}{\Delta} + \frac{s-c}{\Delta} = \frac{s}{\Delta} = \frac{1}{r} = \text{R.H.S.}$$

$$\text{(ii) } \frac{b-c}{r_1} + \frac{c-a}{r_2} + \frac{a-b}{r_3} = \frac{1}{\Delta} [(b-c)(s-a) + (c-a)(s-b) + (a-b)(s-c)]$$

$$= 1/\Delta = [s(b-c+c-a+a-b) + (-ab+ca-cb+ab-ac+bc)] = 0$$

$$\text{(iii) } a(r r_1 + r_2 r_3) = a \left[ \frac{\Delta}{s} \cdot \frac{\Delta}{s-a} + \frac{\Delta}{(s-b)} \cdot \frac{\Delta}{(s-c)} \right] = \frac{a\Delta^2}{\Delta^2}$$

$$= \frac{a\Delta^2}{\Delta^2} [(s-b)(s-c) + s(s-a)]$$

$$= a[(s-b)(s-c) + s(s-a)] = a[2s^2 - s(a+b+c) + bc]$$

$$= a[2s^2 - 2s^2 + bc] = abc$$

$$\text{Similarly } b(r r_2 + r_1 r_3) = c(r r_3 + r_1 r_2) = abc$$

$$\text{(iv) R.H.S.} = a \cos A + b \cos B + c \cos C$$

$$= 2R \sin A \cos A + 2R \sin B \cos B + 2R \sin C \cos C = R[\sin 2A + \sin 2B + \sin 2C]$$

$$= R[2\sin(A+B) \cos(A-B) + 2\sin C \cos C]$$

$$= 2R \sin C [\cos(A-B) - \cos(A+B)] = 4R \sin A \sin B \sin C = \text{L.H.S.}$$

$$\text{(v) } \Delta = \frac{1}{2} ab \sin C = \frac{1}{2} (2R \sin A) (2R \sin B) \sin C = 2R^2 \sin A \sin B \sin C$$

$$= 2R^2 \left( 2\sin \frac{A}{2} \cos \frac{A}{2} \right) \left( 2\sin \frac{B}{2} \cos \frac{B}{2} \right) \left( 2\sin \frac{C}{2} \cos \frac{C}{2} \right) = 16R^2 \left( \sin \frac{A}{2} \sin \frac{B}{2} \sin \frac{C}{2} \right) \left( \cos \frac{A}{2} \cos \frac{B}{2} \cos \frac{C}{2} \right)$$

$$= 16R^2 \frac{r}{4R} \cdot \cos \frac{A}{2} \cdot \cos \frac{B}{2} \cdot \cos \frac{C}{2} \left( r \quad 4R \sin \frac{A}{2} \sin \frac{B}{2} \sin \frac{C}{2} \right)$$

$$= 4Rr \cos \frac{A}{2} \cdot \cos \frac{B}{2} \cdot \cos \frac{C}{2}$$

$$\text{(b) } (r_2 - r_1)(r_3 - r_1) = 2r_2 r_3$$

$$\Rightarrow \left[ \frac{1}{s-b} - \frac{1}{s-a} \right] \left[ \frac{1}{s-c} - \frac{1}{s-a} \right] = 2 \left( \frac{1}{s-b} \right) \left( \frac{1}{s-c} \right)$$

$$\Rightarrow \frac{(b-a)(c-a)}{(s-a)^2 (s-b)(s-c)} = \frac{2}{(s-b)(s-c)}$$

$$\Rightarrow \frac{(b-a)(c-a)}{(s-a)^2} = 2$$

$$\Rightarrow (b-a)(c-a) = 2 \left( \frac{b+c-a}{4} \right)^2$$

$$\Rightarrow b^2 + c^2 = a^2 \quad \Rightarrow \Delta \text{ is a right } \angle d \Delta.$$

3.98 > Trigonometry

(c) To prove  $r + 2R = s$  in a rt.  $\triangle ABC$

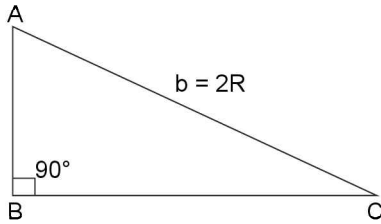

$$\begin{aligned} \text{Here, } r + 2R &= \frac{\Delta}{s} + b = \frac{1}{2} \frac{ac}{s} + b = \frac{ac + b(a+b+c)}{(a+b+c)} \\ &= \frac{ac + (ba + b^2 + bc)}{(a+b+c)} = \frac{2b^2 + 2ab + 2bc + 2ca}{2(a+b+c)} \\ &= \frac{b^2 + (b^2) + 2ab + 2bc + 2ca}{2(a+b+c)} \quad (\because b^2 = a^2 + c^2) \\ &= \frac{(a+b+c)^2}{2(a+b+c)} = \frac{a+b+c}{2} = s \end{aligned}$$

$$\begin{aligned} 4. \Delta &= \frac{1}{2} (\text{base}) \times (\text{altitude}) = \frac{1}{2} a \times AD = \frac{1}{2} a (b \sin C) \\ &= \frac{1}{2} ab \left( 2 \sin \frac{C}{2} \cos \frac{C}{2} \right) = ab \sqrt{\frac{(s-a)(s-b)}{ab}} \sqrt{\frac{s(s-c)}{ab}} \\ &= \sqrt{s(s-a)(s-b)(s-c)} \\ \text{Again } \Delta &= \frac{1}{2} ab \sin C = \frac{1}{2} ab \left( \frac{C}{2R} \right) = \frac{abc}{4R}, \\ &\quad \left( \because \frac{a}{\sin A} = \frac{b}{\sin B} = \frac{c}{\sin C} = 2R \right) \\ \text{Further } \Delta &= \frac{1}{2} ab \sin C = \frac{1}{2} k^2 \sin A \sin B \sin C \\ &= \frac{1}{2} \left( \frac{a}{\sin A} \right)^2 \sin A \sin B \sin C \\ &= \frac{a^2 \sin B \sin C}{2 \sin A} \\ \text{Now, } \Delta &= \frac{abc}{4R} = \frac{abc \cdot abc}{4R(4R\Delta)}, \left( \because \Delta = \frac{abc}{4R} \Rightarrow abc = 4R\Delta \right) \\ &= \frac{Rabc}{2\Delta} \cdot \frac{a}{2R} \cdot \frac{b}{2R} \cdot \frac{c}{2R} = \frac{Rabc}{2rs} \cdot \sin A \cdot \sin B \cdot \sin C \\ &\quad \left( \because \Delta = rs \text{ and } \frac{a}{2R} = \sin A \text{ etc.} \right) \\ &= \frac{Rabc \cdot \sin A \cdot \sin B \cdot \sin C}{2s \left( 4R \sin \frac{A}{2} \sin \frac{B}{2} \sin \frac{C}{2} \right)} = \frac{abc \cdot \cos \frac{A}{2} \cos \frac{B}{2} \cos \frac{C}{2}}{8} \\ &= \frac{4R\Delta}{5} \cos \frac{A}{2} \cos \frac{B}{2} \cos \frac{C}{2} \\ &= 4Rs \cos \frac{A}{2} \cos \frac{B}{2} \cos \frac{C}{2} \quad (\text{using } r = \Delta/s) \end{aligned}$$

5. (a) Given  $r_1 + r_2 + r_3 + r$ , To Prove:  $\Delta$  is right angled

$$\begin{aligned} \Rightarrow \frac{\Delta}{s-a} &= \frac{\Delta}{s-b} + \frac{\Delta}{s-c} + \frac{\Delta}{s} \\ \Rightarrow \frac{1}{s-a} &= \frac{1}{s-b} + \frac{1}{s-c} + \frac{1}{s} \\ \Rightarrow \frac{2}{b+c-a} &= \frac{2}{a+c-b} + \frac{2}{a+b-c} + \frac{2}{a+b+c} \\ \Rightarrow \frac{1}{(b+c)-a} - \frac{1}{(b+c)+a} &= \frac{1}{a+c-b} + \frac{1}{a+b-c} \\ \Rightarrow b^2 + c^2 &= a^2 \text{ (on simplification)} \\ \Rightarrow \Delta &\text{ is a right angled} \end{aligned}$$

$$\begin{aligned} \text{(b) L.H.S.} &= r \cot \frac{B}{2} \cdot \cot \frac{C}{2} = r \\ &= \sqrt{\frac{s(s-b)}{(s-a)(s-c)}} \times \frac{s(s-c)}{(s-a)(s-b)} \\ &= r \cdot \frac{s}{(s-a)} = \frac{rs}{(s-a)} = \frac{\Delta}{(s-a)} = r_1 = \text{R.H.S.} \end{aligned}$$

$$\begin{aligned} \text{(c) L.H.S.} &= \frac{s^2}{\Delta^2} + \frac{(s-a)^2}{\Delta^2} + \frac{(s-b)^2}{\Delta^2} + \frac{(s-c)^2}{\Delta^2} = \frac{1}{\Delta^2} \\ &[s^2 + (s-a)^2 + (s-b)^2 + (s-c)^2] \\ &= \frac{1}{\Delta^2} [4s^2 + s(-2a - 2b - 2c) + a^2 + b^2 + c^2] \\ &= \frac{1}{\Delta^2} [4s^2 - 4s^2 + a^2 + b^2 + c^2] = \frac{a^2 + b^2 + c^2}{\Delta^2} = \text{R.H.S.} \end{aligned}$$

$$\begin{aligned} \text{(d) L.H.S.} &= 4R \sin \frac{A}{2} \cos \frac{B}{2} \cos \frac{C}{2} + 4R \cos \frac{A}{2} \sin \frac{B}{2} \cos \frac{C}{2} \\ &+ 4R \cos \frac{A}{2} \cos \frac{B}{2} \sin \frac{C}{2} - 4R \sin \frac{A}{2} \sin \frac{B}{2} \sin \frac{C}{2} \\ &= 4R \left[ \cos \frac{C}{2} \left( \sin \left( \frac{A}{2} + \frac{B}{2} \right) \right) + \sin \frac{C}{2} \left( \cos \left( \frac{A}{2} + \frac{B}{2} \right) \right) \right] \\ &= 4R \left[ \cos^2 \frac{C}{2} + \sin^2 \frac{C}{2} \right] = 4R = \text{R.H.S.} \end{aligned}$$

6.  $r_1, r_2, r_3$  are in H.P.

$$\begin{aligned} \Rightarrow \frac{1}{r_1}, \frac{1}{r_2}, \frac{1}{r_3} &\text{ are in AP} \Rightarrow \frac{1}{r_2} - \frac{1}{r_1} = \frac{1}{r_3} - \frac{1}{r_2} \\ \Rightarrow \frac{(s-b)}{\Delta} - \frac{(s-a)}{\Delta} &= \frac{(s-c)}{\Delta} - \frac{(s-b)}{\Delta} \\ \Rightarrow s-b-s+a &= s-c-s+b \\ \Rightarrow a-b &= b-c \Rightarrow a+c=2b \\ \Rightarrow a, b, c &\text{ are in A.P.} \end{aligned}$$

7. By sine formula in a  $\triangle ABC$ ,

$$\frac{a}{\sin A} = 2R \Rightarrow \frac{a}{R} = 2 \sin A \quad \dots \dots (i)$$

Similarly in  $\triangle OBC$ ,  $\frac{a}{R_1} = 2 \sin \angle BOC$ ; In  $\triangle OCA$ ,  $\frac{b}{R_2} = 2 \sin \angle COA$ ; and in  $\triangle OAB$ ,  $\frac{c}{R_3} = 2 \sin \angle AOB$ ;

$$\therefore \text{L.H.S.} = \frac{a}{R_1} + \frac{b}{R_2} + \frac{c}{R_3} = 2 [\sin \angle BOC + \sin \angle COA + \sin \angle AOB]$$

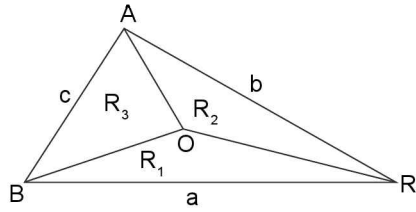

$$= 2[\sin 2A + \sin 2B + \sin 2C] = 2[4 \sin A \sin B \sin C] \text{ (on simplification)}$$

$$= 8 \left( \frac{a}{2R} \right) \left( \frac{b}{2R} \right) \left( \frac{c}{2R} \right) = \frac{abc}{R^3} = \text{R.H.S.}$$

8. In right  $\angle d \triangle ABD$ ,  $AD = AB \sin B = c \sin B = 2R \sin C \sin B$  (by sine formula)  
But  $AD$  is the diameter of circum circle ( $=2R'$ , say) of  $\triangle APQ$

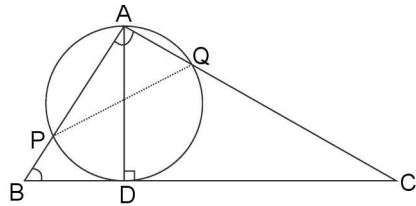

$$\Rightarrow 2R' = 2R \sin C \sin B \quad \dots(i)$$

$\therefore$  By using sine formula to  $\triangle APQ$ , we have,  $\frac{PQ}{\sin A} = 2R'$

$$\Rightarrow PQ = 2R' \sin A = 2R \sin A \sin B \sin C \text{ (from (i))}$$

$$= 2R \left( \frac{a}{2R} \right) \left( \frac{b}{2R} \right) \left( \frac{c}{2R} \right) = \frac{abc}{4R^2} = \frac{abc / 4R}{R} = \frac{\Delta}{R}$$

$$\text{Thus } PQ = 2R \sin A \sin B \sin C = \frac{\Delta}{R}$$

9. In right  $\angle d \triangle AIL$ ,  $\sin \angle IAL = \frac{IL}{AI} = \frac{r}{AI} \Rightarrow AI = r / \sin \angle IAL$

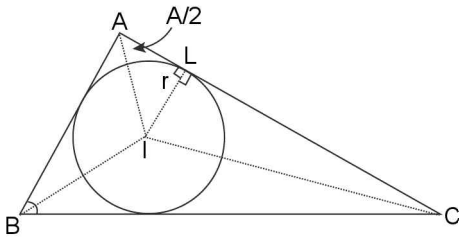

$$\Rightarrow AI = r \sin (A/2) (\because AI \text{ is internal angle bisector of } \angle A)$$

$$\Rightarrow AI = r \operatorname{cosec} (A/2)$$

Similarly  $BI = r \operatorname{cosec} (B/2)$  and  $CI = r \operatorname{cosec} (C/2)$

$$AI : BI : CI = \operatorname{cosec} \frac{A}{2} : \operatorname{cosec} \frac{B}{2} : \operatorname{cosec} \frac{C}{2}$$

10. In a  $\triangle ABC$ ,  $\tan \left( \frac{A}{2} + \frac{B}{2} \right) = \frac{\tan \frac{A}{2} + \tan \frac{B}{2}}{1 - \tan \frac{A}{2} \tan \frac{B}{2}}$

$$\Rightarrow 1 - \tan \frac{A}{2} \tan \frac{B}{2} = \tan \frac{A}{2} \tan \frac{C}{2} + \tan \frac{B}{2} \tan \frac{C}{2}$$

$$= \frac{r_1}{s} \cdot \frac{r_2}{s} + \frac{r_2}{s} \cdot \frac{r_3}{s} \quad \left( \because r_1 = s \tan \frac{A}{2} \text{ etc.} \right)$$

$$= \frac{1}{s^2} \left[ \frac{\Delta^2}{(s-a)(s-c)} + \frac{\Delta^2}{(s-b)(s-c)} \right]$$

$$\left( \because r_1 = \frac{\Delta}{(s-a)} \text{ etc.} \right)$$

$$= \frac{\Delta^2}{s^2} \left[ \frac{(s-b) + (s-a)}{(s-a)(s-b)(s-c)} \right] = \frac{\Delta}{r^2} \left[ \frac{c}{(s-a)(s-b)(s-c)} \right]$$

$$= \frac{\Delta^2}{s} \cdot \frac{c}{\Delta^2} = \frac{c}{s} = \frac{2c}{a+b+c}$$

**TEXTUAL EXERCISE-4 (OBJECTIVE)**

- (c)  $2R^2 \sin A \sin B \sin C = 1/2 (2R \sin A) (2R \sin B) \sin C = 1/2 ab \sin C = \Delta$
- (c)  $b = 6, c = 8, \angle A = 90^\circ$ . In a right  $\angle d \triangle$ ,  $2R$  hypotenuse  
 $\Rightarrow 2R = a = \sqrt{b^2 + c^2} = \sqrt{100} = 10$   
 $\Rightarrow R = 5$
- (b)  $a = 3k, b = 7k, c = 8k$   
 $r = 4R \sin A/2, \sin B/2, \sin C/2$   
 $\Rightarrow \frac{R}{r} = \frac{1}{4 \sin \frac{A}{2} \sin \frac{B}{2} \sin \frac{C}{2}}$   
 $= \frac{1}{4 \sqrt{\frac{(s-b)(s-c)}{bc} \times \frac{(s-a)(s-c)}{ac} \times \frac{(s-a)(s-b)}{ab}}}$   
 $= \frac{abc}{4(s-a)(s-b)(s-c)} = \frac{(3k)(7k)(8k)}{4(6k)(2k)(k)} = \frac{7}{2}$   
 $\therefore R = r = 7 : 2$
- (c) Given  $a = 13, b = 14, c = 15 \Rightarrow s = 42/5 = 21$

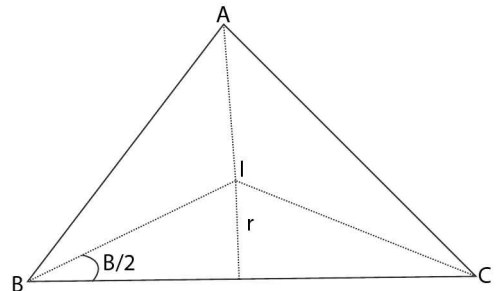

$$r = \frac{\Delta}{s} = \frac{\sqrt{s(s-a)(s-b)(s-c)}}{s} = \sqrt{\frac{(s-a)(s-b)(s-c)}{s}}$$

$$= \sqrt{\frac{(8)(7)(6)}{21}} = 4$$

**3.100** > Trigonometry

5. (a)  $a = 3, b = 5, c = 6 \Rightarrow s = 7$

$$\therefore r = \frac{\Delta}{s} = \frac{\sqrt{(s-a)(s-b)(s-c)}}{s} = \frac{\sqrt{(4)(2)(1)}}{7} = \sqrt{\frac{8}{7}}$$

6. (c)  $a = b = c, r = 1, R = ?$

$$\therefore r = 4R \sin \frac{A}{2} \sin \frac{B}{2} \sin \frac{C}{2}$$

$$\Rightarrow 1 = 4R \sin \frac{\pi}{6} \sin \frac{\pi}{6} \sin \frac{\pi}{6}$$

$$\Rightarrow 1 = 4R \left(\frac{1}{2}\right) \left(\frac{1}{2}\right) \left(\frac{1}{2}\right) \Rightarrow R = 2$$

7. (b) From the above question 6.

$$r = R/2$$

8. (a)  $a = 5k, b = 6k, c = 5k, r = 6, k = ?$

$$\therefore r = \Delta/3 = r = \frac{\Delta}{s} = \frac{\sqrt{(s-a)(s-b)(s-c)}}{s}$$

$$\Rightarrow 6 = \sqrt{\frac{(3k)(2k)(3k)}{8k}} \Rightarrow 6 = 3/2 k$$

$$\Rightarrow k = 4$$

9. (c)  $b = 2, B = 30^\circ$ . To find area of circumcircle of  $\Delta ABC$

$$2R = \frac{b}{\sin B} = \frac{2}{\sin 30^\circ} = 4 \Rightarrow R = 2$$

$$\therefore \text{Area of circumcentre} = \pi R^2 = 4\pi$$

10. (b)  $a = 13, b = 12, c = 5, s = 15$

$$\therefore R = \frac{abc}{4\Delta}$$

$$\Rightarrow R = \frac{(13)(12)(5)}{4\sqrt{s(s-a)(s-b)(s-c)}} = \frac{195}{\sqrt{15(2)(3)(10)}}$$

$$= \frac{195}{30} = \frac{13}{2}$$

11. (b) Given  $r_1, r_2$  and  $r_3$  are in A.P.

$$\Rightarrow s \tan \frac{A}{2}, s \tan \frac{B}{2}, s \tan \frac{C}{2} \text{ are in A.P.}$$

$$\Rightarrow \tan \frac{A}{2}, \tan \frac{B}{2}, \tan \frac{C}{2} \text{ are in A.P.}$$

$$\Rightarrow \cot \frac{A}{2}, \cot \frac{B}{2}, \cot \frac{C}{2} \text{ are in H.P.}$$

12. (b) Given  $r_1 = 2r_2 = 3r_3$ .

$$\Rightarrow s \tan \frac{A}{2} = 2s \tan \frac{B}{2} = 3s \tan \frac{C}{2}$$

$$\Rightarrow \tan \frac{A}{2} = 2 \tan \frac{B}{2} = 3 \tan \frac{C}{2} = k(\text{say})$$

$$\Rightarrow \tan \frac{A}{2} = k; \tan \frac{B}{2} = \frac{k}{2}; \tan \frac{C}{2} = \frac{k}{3}$$

$$\text{Now, } \sum \tan \frac{A}{2} \cdot \tan \frac{B}{2} = 1 \text{ (In } \Delta ABC)$$

$$\Rightarrow \frac{k^2}{2} + \frac{k^2}{6} + \frac{k^2}{3} = 1 \Rightarrow k^2 = 1$$

$$\Rightarrow k = 1$$

( $\because \tan A/2$  etc are +ve)

$$\Rightarrow \tan \frac{A}{2} = 1, \tan \frac{B}{2} = \frac{1}{2}, \tan \frac{C}{2} = \frac{1}{3}$$

$$\Rightarrow A = \pi/2 \quad \Rightarrow R = a/2$$

$$b = 2R \sin B = a \left[ \frac{2 \tan \left(\frac{B}{2}\right)}{1 + \tan^2 \left(\frac{B}{2}\right)} \right] = a \left[ \frac{1}{1 + \frac{1}{4}} \right] = \frac{4a}{5} \text{ and}$$

$$c = 2R \sin C = a \left[ \frac{2 \tan \left(\frac{C}{2}\right)}{1 + \tan^2 \left(\frac{C}{2}\right)} \right] = \frac{\frac{2}{3}a}{1 + \frac{1}{9}} = \frac{3}{5}a$$

$$\therefore (a + b + c) = a + \frac{4a}{5} + \frac{3a}{5} = \frac{12a}{5} = \frac{12}{5} \left(\frac{5}{4}b\right) = \frac{12}{5} \left(\frac{5}{3}c\right)$$

$$\Rightarrow (a + b + c) = \frac{12}{5}a = 3b = 4c$$

13. (d)  $2r (\sin A + \sin B + \sin C)$

$$= 2r \left( \frac{a}{2R} + \frac{b}{2R} + \frac{c}{2R} \right) = \frac{r}{R} (a + b + c) = \frac{r}{R} (2s) = 2\Delta/R$$

$$(\because 2s = \Delta)$$

14. (a)  $r^2 \cot \frac{A}{2} \cot \frac{B}{2} \cot \frac{C}{2}$

$$= r^2 \sqrt{\frac{s(s-a)}{(s-b)(s-c)} \times \frac{s(s-b)}{(s-a)(s-c)} \times \frac{s(s-c)}{(s-a)(s-b)}}$$

$$= r^2 \cdot s = \sqrt{\frac{s^3}{(s-a)(s-b)(s-c)}} = \frac{r^2 \cdot s^2}{\Delta} = \frac{\Delta^2}{\Delta} = \Delta$$

15. (b) In a right angled  $\Delta$ ,  $r + 2R = s$

$$\Rightarrow R = \frac{s-r}{2}$$

16. (c) In an equilateral  $\Delta$ ;  $r_1 = s \tan \frac{A}{2} = \frac{s}{\sqrt{3}} = \frac{\sqrt{3}a}{2}$ ;

$$r_2 = s \tan \frac{B}{2} = \frac{s}{\sqrt{3}} = \frac{\sqrt{3}a}{2}; r_3 = s \tan \frac{C}{2} = \frac{s}{\sqrt{3}} = \frac{\sqrt{3}a}{2}$$

$$r = (s-a) \tan \frac{A}{2} = \frac{a}{2\sqrt{3}} \Rightarrow r_1 = r_2 = r_3 = 3r$$

**TEXTUAL EXERCISE-5 (SUBJECTIVE)**

1.  $R = \frac{a}{2} \operatorname{cosec} \frac{\pi}{n}, r = \frac{a}{2} \cot \frac{\pi}{n}$

$$\therefore R + r = \frac{a}{2} \left[ \operatorname{cosec} \frac{\pi}{n} + \cot \frac{\pi}{n} \right] = \frac{a}{2} \left[ \frac{1}{\sin \pi/n} + \frac{\cos \pi/n}{\sin \pi/n} \right]$$

$$= \frac{a}{2} \left[ \frac{1 + \cos \pi/n}{\sin \pi/n} \right] = \frac{a}{2} \left[ \frac{2 \cos^2 \pi/2n}{2 \sin \frac{\pi}{2n} \cdot \cos \frac{\pi}{2n}} \right] = \frac{a}{2} \cot \left( \frac{\pi}{2n} \right)$$

2. Let the radius of circle be  $r$ , then  $A_1 = \pi r^2$  ... (i)

Also area of regular pentagon is given by

$$A_2 = n \left( \frac{1}{2} r^2 \sin \frac{2\pi}{n} \right); n = 5$$

$$\Rightarrow A_2 = \frac{5}{2} r^2 \sin \left( \frac{2\pi}{5} \right) \quad \dots \dots (ii)$$

$$\therefore \frac{A_1}{A_2} = \frac{\pi r^2}{\frac{5}{2} r^2 \sin \left( \frac{2\pi}{5} \right)} = \frac{2\pi}{5} \operatorname{cosec} \left( \frac{2\pi}{5} \right)$$

3. Let r be the radius of circle.

∴ Perimeter of circle = circumference = 2πr

∴ Perimeter of regular polygon = 2πr

⇒ Each side of regular polygon 2πr/n = a(say)

∴ Area of regular polygon of n-sides

$$= n \frac{a^2}{4} \cot \left( \frac{\pi}{n} \right) = \frac{n}{4} \left( \frac{2\pi r}{n} \right)^2 \cdot \cot \frac{\pi}{n}$$

$$\therefore \frac{\text{Area of circle}}{\text{Area of regular polygon } n\text{-sides}} = \frac{\pi r^2}{\frac{\pi^2 r^2}{n} \cot \left( \frac{\pi}{n} \right)}$$

$$= \frac{n}{\pi \cot \frac{\pi}{n}} = \left( \tan \frac{\pi}{n} \right) : \frac{\pi}{n}$$

4. AB = BC = AC = a ⇒ r =  $\frac{a}{2} \cot \frac{\pi}{n}$ ; n = 3

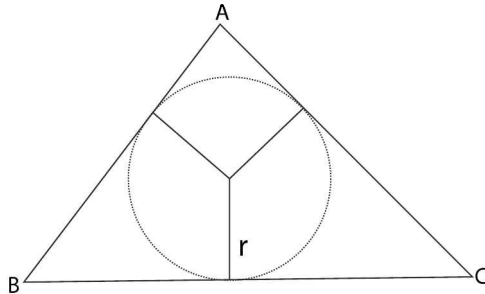

$$\Rightarrow r = \frac{a}{2} \cot \frac{\pi}{3} = \frac{a}{2\sqrt{3}} \quad \dots \dots (i)$$

Now,

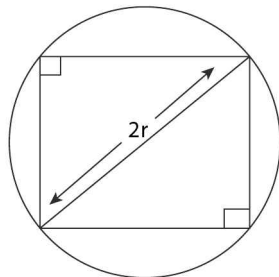

Area of square inscribed in a circle of radius 'r' is given

$$A = \frac{1}{2} (2r)^2 = 2 \left( \frac{a}{2\sqrt{3}} \right)^2 = \frac{a^2}{6} \text{ square units.}$$

5. In right ∠d Δ OLC,  $\cos \frac{\pi}{6} = \frac{LC}{OC} = \frac{r}{OC}$

$$\Rightarrow OC = r \sec \frac{\pi}{6} = \frac{2r}{\sqrt{3}}$$

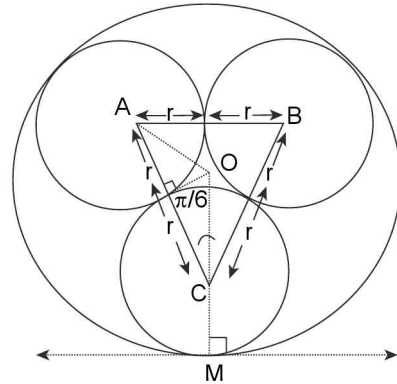

$$\therefore R = MC + OC = r + \frac{2r}{\sqrt{3}} = \frac{(2 + \sqrt{3})r}{\sqrt{3}}$$

6. Here AG + BG > AB ⇒  $\frac{2}{3} l_1 + \frac{2}{3} l_2 > c$

Similarly  $\frac{2}{3} l_2 + \frac{2}{3} l_3 > a$  and  $\frac{2}{3} l_1 + \frac{2}{3} l_3 > b$

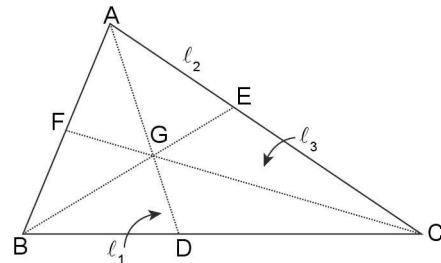

$$\Rightarrow \frac{4}{3} (l_1 + l_2 + l_3) > 2s \Rightarrow l_1 + l_2 + l_3 > 3/2s$$

$$\text{i.e., } \sum l_i > \frac{3}{2}s \quad \dots \dots (i)$$

$$\text{Also } AD < AB + BD \Rightarrow l_1 < c + \frac{a}{2}$$

Similarly  $l_2 < a + b/2$  and  $l_3 < b + c/2$

$$\Rightarrow \sum l_i < \frac{3}{2} (a + b + c) = 3s$$

$$\Rightarrow \sum l_i < 3s \quad \dots \dots (ii)$$

∴ From (i) and (ii),  $\frac{3}{2}s < \sum l_i < 3s$

7. since  $\tan^2 \frac{A}{2}, \tan^2 \frac{B}{2}, \tan^2 \frac{C}{2}$  are positive for ΔABC

∴ By A.M. ≥ G.M.

$$\sum \tan^2 \frac{A}{2} \geq 3 \sqrt{\tan^2 \frac{A}{2} \cdot \tan^2 \frac{B}{2} \cdot \tan^2 \frac{C}{2}}$$

and the minimum value exists for

3.102 > Trigonometry

$$\tan^2 \frac{A}{2} = \tan^2 \frac{B}{2} = \tan^2 \frac{C}{2} \text{ in } \Delta ABC$$

$$\Rightarrow A = B = C = \pi/3$$

$$\Rightarrow \tan^2 \frac{A}{2} = \tan^2 \frac{B}{2} = \tan^2 \frac{C}{2} = \frac{1}{3}$$

$$\therefore \sum \tan^2 \frac{A}{2} \geq 3 \cdot \sqrt[3]{\frac{1}{27}} = 1$$

$$\therefore \text{Minimum value of } \sum \tan^2 \frac{A}{2} = 1$$

8. We have  $\sum_{1 \leq i < j \leq (n-1)} (a_i - a_j)^2 \geq 0$

$$\Rightarrow (n-2) [a_1^2 + a_2^2 + a_3^2 + \dots + a_{n-1}^2] \geq 2 \sum_{1 \leq i < j \leq n-1} a_i a_j$$

$$\Rightarrow (n-2) \sum_{i=1}^{n-1} a_i^2 + \sum_{i=1}^{n-1} a_i^2 \geq \sum_{i=1}^{n-1} a_i^2 + 2 \sum_{1 \leq i < j \leq n-1} a_i a_j$$

$$\Rightarrow (n-1) \left( \sum_{i=1}^{n-1} a_i^2 \right) \geq \left( \sum_{i=1}^{n-1} a_i \right)^2$$

$$\Rightarrow (n-1) (a_1^2 + a_2^2 + a_3^2 + \dots + a_{n-1}^2) \geq$$

$$(a_1 + a_2 + a_3 + \dots + a_{n-1})^2 > a_n^2$$

$$(\because a_1 + a_2 + a_3 + \dots + a_{n-1} > a_n)$$

$$\Rightarrow \frac{a_1^2 + a_2^2 + a_3^2 + \dots + a_{n-1}^2}{a_n^2} > \frac{1}{(n-1)}$$

9.  $\therefore R = \frac{a}{2 \sin A} = \frac{2 + \sqrt{5}}{2 \cdot \sin 30^\circ}$

$$R = 2 + \sqrt{5}$$

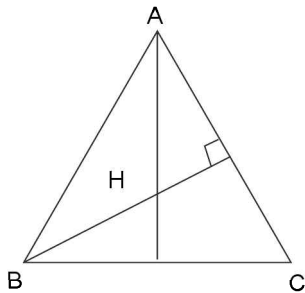

Now  $AH = 2R \cos A$

$$= 2(2 + \sqrt{5}) \cos 30^\circ = (2 + \sqrt{5}) \sqrt{3} = (\sqrt{4} + \sqrt{5}) \sqrt{3}$$

$$\therefore k = 4$$

10.  $\angle A_1 O I_1 = \pi/n$

$$I_n = 2n \times \text{area of } \Delta O A_1 I_1$$

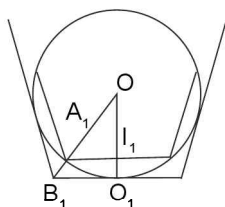

$$= 2n \times \frac{1}{2} \times A_1 I_1 \times O I_1 = n \times \sin \frac{\pi}{n} \times \cos \frac{\pi}{n} = \frac{n}{2} \sin \frac{2\pi}{n}$$

$$O_n = 2n \times \text{area of } \Delta O B_1 O_1 = 2n \times \frac{1}{2} \times B_1 O_1 \times O_1$$

$$= n \times \tan \frac{\pi}{n} \times 1 = n \tan \frac{\pi}{n}$$

Now R.H.S.  $\frac{O_n}{2} \left[ 1 + \sqrt{1 - \sin^2 \frac{2\pi}{n}} \right]$

$$= \frac{O_n}{2} \left[ 1 + \cos \frac{2\pi}{n} \right] = \frac{O_n}{2} \times 2 \cos^2 \frac{\pi}{n} = O_n \cos^2 \frac{\pi}{n}$$

$$= n \tan \frac{\pi}{n} \cos^2 \frac{\pi}{n} = \frac{n}{2} \sin \frac{2\pi}{n} = I_n$$

11. Let IF be the in-radius of triangle ABC.

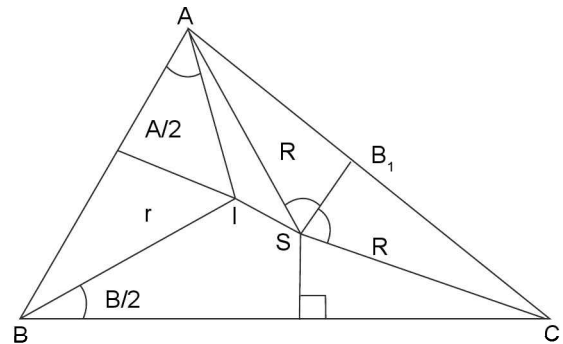

In  $\Delta AIF$ , we have  $\frac{AI}{\sin 90^\circ} = \frac{r}{\sin \frac{A}{2}}$

$$\Rightarrow AI = \frac{r}{\sin \frac{A}{2}} \quad (\text{By sine formula})$$

$$\Rightarrow AI = \frac{4R \sin \frac{A}{2} \sin \frac{B}{2} \sin \frac{C}{2}}{\sin \frac{A}{2}}$$

$$= 4R \sin \frac{B}{2} \sin \frac{C}{2}$$

Also  $\angle SAB_1 = 90^\circ - \angle ASB_1$

$$= 90^\circ - \frac{1}{2} \angle ASC$$

$$= 90^\circ - \angle B$$

$$\angle IAS = \angle IAC - \angle SAC$$

$$= \frac{A}{2} - (90^\circ - \angle B) = \frac{B-C}{2}$$

In  $\Delta ASI$ ,

$$(SI)^2 = (AS)^2 + (AI)^2 - 2(AS)(AI) \cos \angle IAS \text{ (by cosine formula)}$$

$$\Rightarrow (SI)^2 = R^2 + 16R^2 \sin^2 \frac{B}{2} \sin^2 \frac{C}{2} - 2R \times 4R \sin \frac{B}{2} \sin \frac{C}{2} \cos \frac{B-C}{2}$$

$$\begin{aligned}
 &= R^2 \left[ 1 + 8 \sin \frac{B}{2} \sin \frac{C}{2} \left( 2 \sin \frac{B}{2} \sin \frac{C}{2} - \cos \frac{B-C}{2} \right) \right] \\
 &= R^2 \left[ 1 - 8 \sin \frac{B}{2} \sin \frac{C}{2} \cos \frac{B+C}{2} \right] \\
 &= R^2 \left[ 1 - 8 \sin \frac{A}{2} \sin \frac{B}{2} \sin \frac{C}{2} \right] \\
 &= R^2 \left[ 1 - \frac{2}{R} \left( 4R \sin \frac{A}{2} \sin \frac{B}{2} \sin \frac{C}{2} \right) \right] \\
 &= R^2 \left[ 1 - \frac{2r}{R} \right] = R^2 - 2rR \\
 \Rightarrow d^2 &= R^2 - 2rR
 \end{aligned}$$

12. Given,

$$\Delta = \frac{1}{2} ah_1 \quad \Rightarrow h_1 = \frac{2\Delta}{a}$$

Similarly,  $h_2 = \frac{2\Delta}{b}$  and  $h_3 = \frac{2\Delta}{c}$

$$\begin{aligned}
 \therefore \frac{h_1+r}{h_1-r} + \frac{h_2+r}{h_2-r} + \frac{h_3+r}{h_3-r} &= \frac{\frac{2\Delta}{a} + \frac{\Delta}{s}}{\frac{2\Delta}{a} - \frac{\Delta}{s}} + \frac{\frac{2\Delta}{b} + \frac{\Delta}{s}}{\frac{2\Delta}{b} - \frac{\Delta}{s}} + \frac{\frac{2\Delta}{c} + \frac{\Delta}{s}}{\frac{2\Delta}{c} - \frac{\Delta}{s}} \\
 &= \frac{2s+a}{2s-a} + \frac{2s+b}{2s-b} + \frac{2s+c}{2s-c} \\
 &= \frac{4s}{2s-a} + \frac{4s}{2s-b} + \frac{4s}{2s-c} - 3 \\
 &= 3 \left[ \frac{1}{3} \left\{ \frac{4s}{2s-a} + \frac{4s}{2s-b} + \frac{4s}{2s-c} \right\} \right] \\
 -3 &\geq 3 \left[ \frac{3}{\frac{4s}{2s-a} + \frac{4s}{2s-b} + \frac{4s}{2s-c}} \right] - 3 \\
 &\geq 6 \text{ [Using A.M.} \geq \text{H.M.]}
 \end{aligned}$$

13. Let  $I_1, I_2, I_3$  be the centres of the circles of radii  $a, b, c$  respectively which touch externally at points  $D, E$  and  $F$ . If the tangents at  $D, E, F$  meet at  $I$ , then  $ID = IE = IF$  also.  $ID \perp I_2I_3, IE \perp I_3I_1$  and  $IF \perp I_1I_2$   
Hence  $I$  is the incentre of the  $\Delta I_1I_2I_3$ , whose sides are of lengths  
 $I_2I_3 = b + c, I_3I_1 = c + a$  and  $I_1I_2 = a + b$   
Perimeter of  $\Delta I_1I_2I_3 = I_2I_3 + I_3I_1 + I_1I_2$   
 $2s = 2(a + b + c)$   
 $\therefore s = (a + b + c)$   
 $\therefore ID = IE = IF = \text{radius of inscribed circle of } \Delta I_1I_2I_3$   
 $= \frac{\Delta}{s} = \frac{\sqrt{s(s-I_2I_3)(s-I_3I_1)(s-I_1I_2)}}{s}$

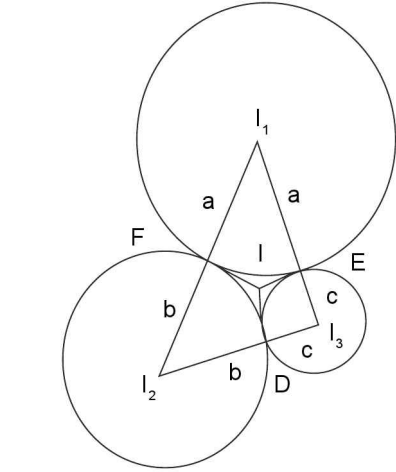

$$\begin{aligned}
 &= \frac{\sqrt{(a+b+c)abc}}{(a+b+c)} \\
 &= \sqrt{\frac{abc}{a+b+c}} = \left( \frac{abc}{a+b+c} \right)^{1/2}
 \end{aligned}$$

14.  $\therefore \angle A_1OA_2 = \angle A_2OA_3 = \dots \dots \dots$   
 $= \angle A_nOA_1 = \frac{2\pi}{n}$

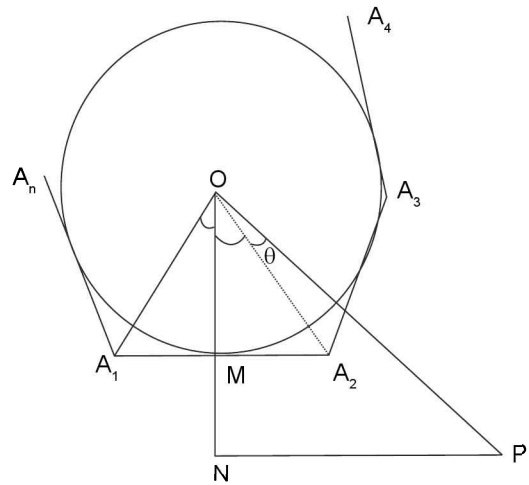

Given  $OP = c,$   
Let  $\angle POA_2 = \theta, OM = a,$   
 $\therefore MN = ON - OM = OP \cos \left( \frac{\pi}{n} + \theta \right) - a$   
 $MN = c \cos \left( \frac{\pi}{n} + \theta \right) - a$   
Similarly length of other perpendiculars are  
 $c \cos \left( \frac{3\pi}{n} + \theta \right) - a, c \cos \left( \frac{5\pi}{n} + \theta \right) - a, \dots \dots$   
 $\therefore \text{sum of squares of the perpendicular P on the sides of polygon} =$



3.104 > Trigonometry

$$\begin{aligned}
 &= \left[ c \cos \left( \theta + \frac{\pi}{n} \right) - a \right]^2 + \left[ c \cos \left( \theta + \frac{3\pi}{n} \right) - a \right]^2 \\
 &+ \left[ c \cos \left( \theta + \frac{5\pi}{n} \right) - a \right]^2 + \dots + n \text{ terms} \\
 &= na^2 - 2ac \left[ \cos \left( \theta + \frac{\pi}{n} \right) + \cos \left( \theta + \frac{3\pi}{n} \right) + \dots + n \text{ term} \right] \\
 &+ c^2 \left[ \cos^2 \left( \theta + \frac{\pi}{n} \right) + \cos^2 \left( \theta + \frac{3\pi}{n} \right) + \dots + n \text{ term} \right] \\
 &= na^2 - 2ac \cdot 0 + \frac{c^2}{2} [n + 0] = n(a^2 + c^2/2)
 \end{aligned}$$

15. Let the circle of radius  $r_A$  touch the sides AB and AC at D and E, whereas the incircle touches these sides at D and E. Let O and O' be the centres of the inscribed and that of the circle with radius  $r_A$ . O and O' lie on the bisector of angle A.

$$\text{Also, } AO' = OD' \operatorname{cosec} \frac{A}{2} = r_A \operatorname{cosec} \frac{A}{2}$$

$$AO = OD \operatorname{cosec} \frac{A}{2} = r \operatorname{cosec} \frac{A}{2}$$

$$\text{Hence, } OO' = r + r_A = AO - AO'$$

$$r + r_A = r \left( \operatorname{cosec} \frac{A}{2} \right) - r_A \left( \operatorname{cosec} \frac{A}{2} \right)$$

$$\therefore \frac{r_A}{r} = \frac{\operatorname{cosec} \frac{A}{2} - 1}{\operatorname{cosec} \frac{A}{2} + 1} \Rightarrow r_A = r \tan^2 \left( \frac{\pi - A}{4} \right)$$

$$\text{Similarly, } r_B = r \tan^2 \frac{\pi - B}{4}, r_C = r \tan^2 \frac{\pi - C}{4}$$

$$\text{Hence, } \sqrt{r_A r_B} + \sqrt{r_B r_C} + \sqrt{r_C r_A}$$

$$= r \left\{ \frac{\tan \frac{\pi - A}{4} \cdot \tan \frac{\pi - B}{4} + \tan \frac{\pi - B}{4} \cdot \tan \frac{\pi - C}{4} + \tan \frac{\pi - C}{4} \cdot \tan \frac{\pi - A}{4}}{\tan \frac{\pi - C}{4} \cdot \tan \frac{\pi - A}{4}} \right\}$$

$$= \frac{r}{\cos \frac{\pi - A}{4} \cos \frac{\pi - B}{4} \cos \frac{\pi - C}{4}}$$

$$\left\{ \sum \sin \frac{\pi - A}{4} \sin \frac{\pi - B}{4} \cos \frac{\pi - C}{4} \right\}$$

$$= \frac{r}{\pi \cos \frac{\pi - A}{4}}$$

$$\left\{ \sin \frac{\pi - A}{4} \left( \sin \frac{\pi - B}{4} \cos \frac{\pi - C}{4} + \sin \frac{\pi - C}{4} \cos \frac{\pi - B}{4} \right) \right.$$

$$\left. + \sin \frac{\pi - B}{4} \sin \frac{\pi - C}{4} \cos \frac{\pi - A}{4} \right\}$$

$$= \frac{r}{\pi \cos \frac{\pi - A}{4}}$$

$$\begin{aligned}
 &\left[ \frac{\cos \pi + A}{4} \cdot \cos \frac{\pi - A}{4} + \sin \frac{\pi - B}{4} \cdot \sin \frac{\pi - C}{4} \cdot \cos \frac{\pi - A}{4} \right] \\
 &= \frac{r \cos \frac{\pi - A}{4}}{\cos \frac{\pi - A}{4} \cdot \cos \frac{\pi - B}{4} \cdot \cos \frac{\pi - C}{4}}
 \end{aligned}$$

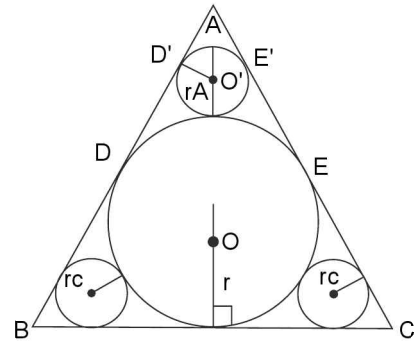

$$\begin{aligned}
 &= \left[ \cos \frac{\pi - B + \pi - C}{4} + \sin \frac{\pi - B}{4} \cdot \sin \frac{\pi - C}{4} \right] \\
 &= \frac{r \cos \frac{\pi - A}{4} \cdot \cos \frac{\pi - B}{4} \cdot \cos \frac{\pi - C}{4}}{\cos \frac{\pi - A}{4} \cdot \cos \frac{\pi - B}{4} \cdot \cos \frac{\pi - C}{4}} = r
 \end{aligned}$$

16. Here

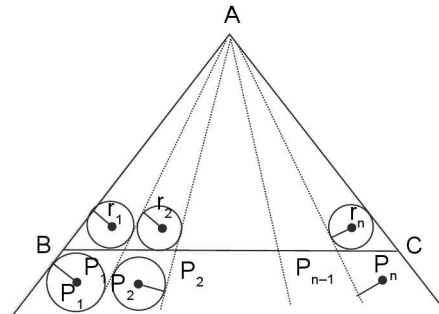

$$r = \frac{\Delta}{s}, P = \frac{\Delta}{s - a}$$

$$\therefore \frac{r}{P} = \frac{s - a}{s}$$

$$\text{Also, } \tan \frac{B}{2} \cdot \tan \frac{C}{2} = \frac{s - a}{s}$$

$$\Rightarrow \frac{r}{P} = \tan \frac{B}{2} \cdot \tan \frac{C}{2} \quad \dots \text{ (i)}$$

$$\text{Let } \angle AP_1 B = \alpha_1, \angle AP_2 P_1 = \alpha_2,$$

$$\angle AP_3 P_2 = \alpha_3, \dots, \angle AP_{n-1} P_{n-2} = \alpha_{n-1}$$

$$\therefore \frac{r_1}{P_1} = \tan \frac{B}{2} \tan \frac{\alpha_1}{2} \quad \dots \text{ (ii)}$$

$$\frac{r_2}{P_2} = \tan \left( \frac{\pi - \alpha_1}{2} \right) \tan \frac{\alpha_2}{2} \quad \dots \text{ (iii)}$$

$$\frac{r_3}{P_3} = \tan\left(\frac{\pi - \alpha_2}{2}\right) \tan \frac{\alpha_3}{2} \quad \dots \text{(iv)}$$

$$\frac{r_n}{P_n} = \tan\left(\frac{\pi - \alpha_{n-1}}{2}\right) \tan \frac{C}{2} \quad \dots \text{(v)}$$

Multiplying all above equations, we get

$$\frac{r_1}{P_1} \cdot \frac{r_2}{P_2} \dots \frac{r_n}{P_n} = \tan \frac{B}{2} \cdot \tan \frac{C}{2} = \frac{r}{P} \quad [\text{using (i)}]$$

**TEXTUAL EXERCISE-5 (OBJECTIVE)**

1. (b)  $c^2 = AM^2 + BM^2$

$b^2 = AM^2 + MC^2$

$$c^2 - b^2 = BM^2 - MC^2 = \left[\frac{a}{2} - x\right]^2 - \left[x + \frac{a}{2}\right]^2$$

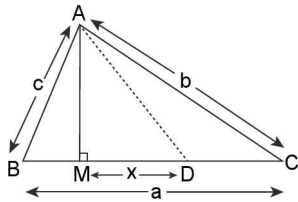

On simplification  $\frac{c^2 - b^2}{2a} = -x$

$\Rightarrow DM = \frac{b^2 - c^2}{2a}$  for  $b > c$  and  $DM = \frac{c^2 - b^2}{2a}$  for  $c > b$

$\therefore DM = \frac{c^2 - b^2}{2a}$

2. (c) Circle through D, E, F is nine point circle having its radius equal to half the circum radius of  $\Delta ABC$  is  $R/2$ .

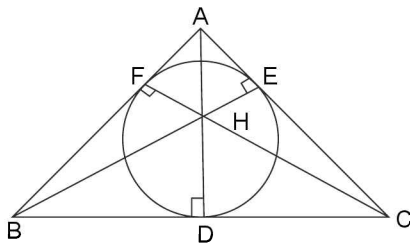

3. (a, b, d)

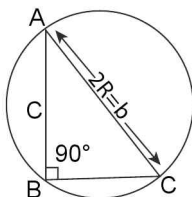

(a)  $\Delta = \frac{1}{2}ac = \frac{1}{2}a\sqrt{b^2 - a^2} = \frac{1}{2}a\sqrt{4R^2 - a^2} \quad \dots \text{(i)}$

By A.M.  $\geq$  G.M., we have,  $a^2 + (4R^2 - a^2) \geq 2\sqrt{a^2 \cdot (4R^2 - a^2)}$

$\Rightarrow 4R^2 \geq 2a\sqrt{4R^2 - a^2} \Rightarrow \frac{1}{2}a\sqrt{4R^2 - a^2} \leq R^2 \quad \dots \text{(ii)}$

$\therefore$  From (i) and (ii), we get  $\Delta \leq R^2$

$\therefore$  Area of triangle with maximum area is  $R^2$

$\therefore$  (a) is correct

(b) Now, for maximum area  $\Delta$ ,  $a^2 = 4R^2 - a^2$

$\Rightarrow a^2 = 2R^2 \quad \Rightarrow a = \sqrt{2}R$

$\Rightarrow c = \sqrt{2}R$

Thus  $a = \sqrt{2}R, b = 2R, c = \sqrt{2}R$

$\Rightarrow \angle A = \angle C = \pi/4, \angle B = \pi/2$

Now,  $r = \frac{\Delta}{s} = \frac{R^2}{(2\sqrt{2} + 2)R} = \frac{R}{\sqrt{2} + 1} = (\sqrt{2} - 1)R$

$\therefore$  (b) is correct

(c)  $\frac{1}{r_1} + \frac{1}{r_2} + \frac{1}{r_3} = \frac{1}{\Delta} (s - a + s - b + s - c)$

$= \frac{s}{\Delta} = \frac{1}{r} = \frac{1}{(\sqrt{2} - 1)R} = \frac{\sqrt{2} + 1}{R}$

$\Rightarrow$  (c) is incorrect

(d)  $s = 1/2 (a + b + c) = 1/2 (2R + 2\sqrt{2}R) = (1 + \sqrt{2})R$

$\Rightarrow$  (d) is correct

4. (b) In right  $\angle d \Delta AQC$ ,  $AQ = \sqrt{(QC)^2 + (AC)^2} = 13\text{cm}$

$\therefore$  Length of each shing = 13cm

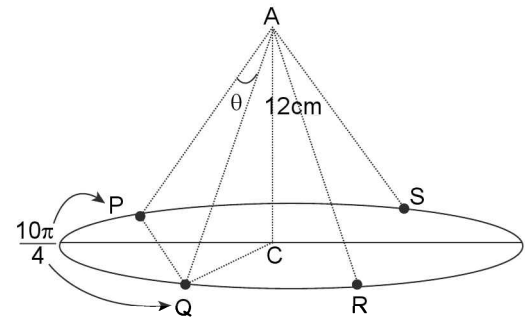

Now PQRS is a rhombus inscribed in a circle of radius  $R = 5$  with each side 'a'

$\Rightarrow R = \frac{a}{2\sin \frac{\pi}{4}} \quad \Rightarrow 5 = \frac{a}{\sqrt{2}}$

$\Rightarrow a = 5\sqrt{2} \text{ cm} \quad \Rightarrow PQ = 5\sqrt{2} \text{ cm}$

$\therefore$  In  $\Delta APQ$ ,  $\cos \theta = \frac{(AP)^2 + (AQ)^2 - (PQ)^2}{2(AP)(AQ)}$

$\Rightarrow \cos \theta = \frac{(13)^2 + (13)^2 - (5\sqrt{2})^2}{2(13)(13)}$

$\Rightarrow \cos \theta = \frac{144}{169} \Rightarrow \sqrt{\cos \theta} = \frac{12}{13}$

3.106 > Trigonometry

5. (b) Since no gap is left at common vertex  
 ⇒ Sum of interior angles of polygons must be  $2\pi$   
 ⇒  $\alpha_1 + \alpha_2 + \alpha_3 + \dots + \alpha_k = 2\pi$   
 ⇒  $\sum_{i=1}^k \left( \frac{n_i - 2}{n_i} \right) \pi = 2\pi \Rightarrow \sum_{i=1}^k \left( 1 - \frac{2}{n_i} \right) = 2$   
 ⇒  $k - 2 \sum_{i=1}^k \frac{1}{n_i} = 2 \Rightarrow \sum_{i=1}^k \frac{1}{n_i} = \frac{(k-2)}{2}$

6. (a, b) Area of PQRS =  $4\sqrt{3}$  ... (i)  
 ⇒  $\frac{1}{2}(ad + bc) \sin P = 4\sqrt{3}$   
 ⇒  $(2d + bc) \sin P = 8\sqrt{3}$  ... (ii)

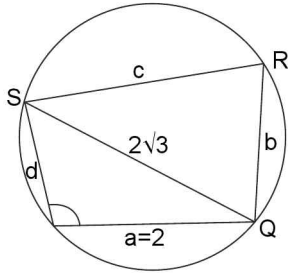

In  $\Delta PQS$ , by sine formula,  $\frac{2\sqrt{3}}{\sin P} = 2R$ ;  $R$  = radius of circumscribed  $\Delta PQR$  which is same as that for  $\Delta PQR = 2$  (given)

- ⇒  $\sin P = \sqrt{3}/2 \Rightarrow \cos P = \pm 1/2$  ... (iii)  
 ⇒  $\pm \frac{1}{2} = \frac{4 + d^2 - 12}{2(2)(d)} \Rightarrow \pm 2d = d^2 - 8$   
 ⇒  $d^2 \mp 2d - 8 = 0$   
 ⇒  $d = 2$  or  $d = 4$  ... (iv)  
 ∴ From (ii) and (iii) and (iv);  $bc = 16 - 2d = 12$  or  $8$   
 ⇒  $(QR) \cdot (SR) = 12$  or  $8$

7. (c)  $\cos\left(\psi + \frac{\pi}{2}\right), \cos\left(\theta + \frac{\pi}{2}\right), \cos\left(\phi + \frac{\pi}{2}\right) = -\sin\psi, -\sin\theta,$   
 $-\sin\phi = -\sin 2A, -\sin 2B, -\sin 2C$

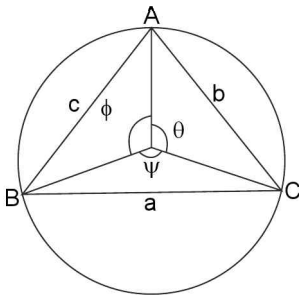

Now,  $\sin 2A + \sin 2B + \sin 2C = 4 \sin A \sin B \sin C$

Now,  $\sin A, \sin B, \sin C > 0$  for  $\Delta ABC$

⇒  $\sqrt[3]{\sin A \cdot \sin B \cdot \sin C} \leq \frac{\sin A + \sin B + \sin C}{3}$

And maximum value exists for  $\sin A = \sin B = \sin C = \sqrt{3}/2$

- ⇒  $\sin A \cdot \sin B \cdot \sin C \leq \left(\frac{\sqrt{3}}{2}\right)^3 = \frac{3\sqrt{3}}{8}$   
 ⇒  $4 \sin A \cdot \sin B \cdot \sin C \leq \frac{3\sqrt{3}}{2}$   
 ⇒  $-4 \sin A \cdot \sin B \cdot \sin C \geq \frac{-3\sqrt{3}}{2}$   
 ⇒  $-\sin 2A - \sin 2B - \sin 2C \geq \frac{-3\sqrt{3}}{2}$   
 ⇒  $\frac{-\sin 2A - \sin 2B - \sin 2C}{3} \geq \frac{\sqrt{3}}{2}$   
 ⇒ A.M of  $\cos\left(\psi + \frac{\pi}{2}\right), \cos\left(\theta + \frac{\pi}{2}\right), \cos\left(\phi + \frac{\pi}{2}\right) \geq \frac{-\sqrt{3}}{2}$   
 ⇒ Minimum value of  $\cos\left(\psi + \frac{\pi}{2}\right), \cos\left(\theta + \frac{\pi}{2}\right), \cos\left(\phi + \frac{\pi}{2}\right)$  is  $-\sqrt{3}/2$

8. (d)  $r = \frac{a}{2} \cot \frac{\pi}{n}; R = \frac{a}{n} \operatorname{cosec} \frac{\pi}{n}$

∴  $\frac{r}{R} = \frac{\cot \frac{\pi}{n}}{\operatorname{cosec} \frac{\pi}{n}} = \cos \frac{\pi}{n}; n \geq 3$  and  $\frac{\pi}{n} > 0$

For  $n = 3, \frac{r}{R} = \cos \frac{\pi}{3} = \frac{1}{2} \Rightarrow$  (b) is true

For  $n = 4, \frac{r}{R} \cos \frac{\pi}{4} = \frac{1}{\sqrt{2}} \Rightarrow$  (c) is true

For  $n = 5, r/R = \cos \pi/5$

For  $n = 6, r/R = \cos \pi/6 = \sqrt{3}/2$

⇒ (a) is true

In  $[0, \pi]$ ,  $\cos x$  is a decreasing function.

⇒  $\cos \frac{\pi}{3} < \cos \frac{\pi}{4} < \cos \frac{\pi}{5} < \cos \frac{\pi}{6}$

⇒  $0.5 < 0.707 < \cos \pi/5 < 0.867$

and  $\frac{2}{3} \approx 0.67 \in \left(\cos \frac{\pi}{3}, \cos \frac{\pi}{4}\right)$

And hence it can't be attained by  $\cos \pi/n$  for any natural number  $n$ .

9. (a, b, c, d)  $A = \pi r^2; r = \Delta/s;$

$A_1 = \pi r_1^2; r_1 = \frac{\Delta}{s-a}; A_2 = \pi r_2^2; r_2 = \frac{\Delta}{s-b};$

$A_3 = \pi r_3^2; r_3 = \frac{\Delta}{(s-c)}$

∴  $\sqrt{A_1} + \sqrt{A_2} + \sqrt{A_3} = \sqrt{\pi}(r_1 + r_2 + r_3)$

⇒ (a) is true

Also  $r_1 + r_2 + r_3 = r + 4R$  is true

⇒  $\sqrt{A_1} + \sqrt{A_2} + \sqrt{A_3} = \sqrt{\pi}(4R + r)$

⇒ (b) is also true

$$\begin{aligned} \text{Now, } & \frac{1}{\sqrt{A_1}} + \frac{1}{\sqrt{A_2}} + \frac{1}{\sqrt{A_3}} \\ &= \frac{1}{\sqrt{\pi}} \cdot \left( \frac{1}{r_1} + \frac{1}{r_2} + \frac{1}{r_3} \right) = \frac{1}{\sqrt{\pi}} \cdot \frac{1}{r} = \sqrt{\frac{1}{\pi r^2}} = \frac{1}{\sqrt{A}} \end{aligned}$$

⇒ (c) is also true

$$\begin{aligned} \text{Also } & \frac{1}{\sqrt{A_1}} + \frac{1}{\sqrt{A_2}} + \frac{1}{\sqrt{A_3}} = \frac{1}{\sqrt{\pi}} \cdot \frac{1}{r} = \frac{1}{\sqrt{\pi}} \left( \frac{1}{r_1} + \frac{1}{r_2} + \frac{1}{r_3} \right) \\ &= \frac{1}{\sqrt{\pi}} \left( \frac{r_2 r_3 + r_1 r_3 + r_1 r_2}{r_1 r_2 r_3} \right) \\ &= \frac{1}{\sqrt{\pi}} \left[ \frac{\Delta^2}{(s-b)(s-c)} + \frac{\Delta^2}{(s-a)(s-c)} + \frac{\Delta^2}{(s-a)(s-b)} \right] \cdot \frac{1}{r_1 r_2 r_3} \\ &= \frac{\Delta^2}{\sqrt{\pi}} \left[ \frac{(s-a) + (s-b) + (s-c)}{(s-a)(s-b)(s-c)} \right] \cdot \frac{1}{r_1 r_2 r_3} \\ &= \frac{\Delta^2}{\sqrt{\pi}} \left[ \frac{s}{(s-a)(s-b)(s-c)} \right] \cdot \frac{1}{r_1 r_2 r_3} = \frac{1}{\sqrt{\pi}} \frac{s^2}{r_1 r_2 r_3} \end{aligned}$$

⇒ (d) is correct

10. (b)  $\angle BIC = 180 - \frac{90-C}{2} - \frac{90-B}{2}$

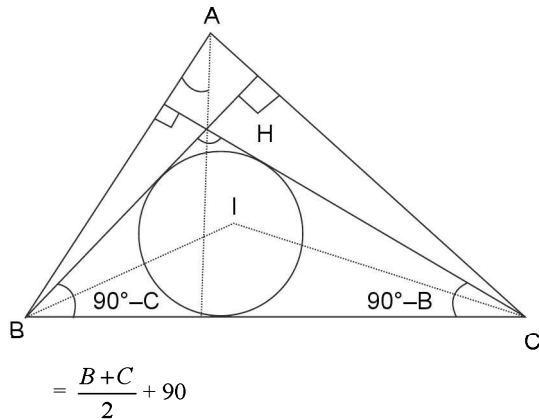

11. (c) Given  $a = b = c$

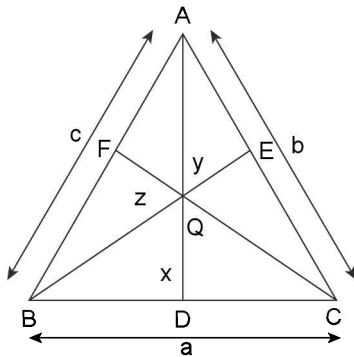

Area of triangle ABC =  $\frac{\sqrt{3}}{4} a^2$  = area of triangle ABQ + area of triangle BQC + area of triangle CQA

$$\frac{\sqrt{3}}{4} a^2 = \frac{1}{2} ax + \frac{1}{2} by + \frac{1}{2} cz$$

$$\frac{\sqrt{3}}{2} a = (x + y + z) = P$$

12. (a)  $r_1 = s \tan A/2$ ,

Given  $2s \tan A/2 = 2s$ ,  $\tan A/2 = 1$ ,  $A = \pi/2$ .

You can not say about right angled triangle.

13. (a) Let  $AB = 1$  be one of the sides of the polygon.

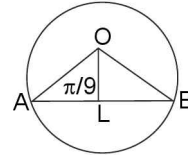

Then AB subtends an angle of  $2\pi/9$  at the centre O of the circle. Let  $OL \perp AB$ .

Radius of the circle =  $OA = AL \operatorname{cosec}(\pi/9)$   
 $\operatorname{cosec}(\pi/9)$

14. (b) Let O be the foot of the tower of height h and  $\alpha$  be the angle of elevation.

Hence  $OA = OB = OC = h \cot \alpha$

Therefore ABC has O as a point of circumcentre

15. (b)  $\because 4R \sin \frac{A}{2} = 4$

$$\Rightarrow R = 2$$

$$\therefore R = 2r = 2$$

$$\Rightarrow r = 1$$

16. (a, d) We have  $r(r_1 r_2 + r_2 r_3 + r_3 r_1)$

$$= \frac{\Delta^3}{(s-a)(s-b)(s-c)} \text{ and}$$

$$r_1 r_2 r_3 = \frac{\Delta^3}{(s-a)(s-b)(s-c)}$$

$\therefore x^2 - r(r_1 r_2 + r_2 r_3 + r_3 r_1)x + r_1 r_2 r_3 - 1 = 0$  is satisfied by  $x = 1$ .  
So, one root is  $x = 1$  and other root is therefore  $r_1 r_2 r_3 - 1$ .

**SECTION-III (ONLY ONE CORRECT ANSWER)**

1. (b)  $C = 2b$ ,  $\angle C = \angle B + \pi/3 = \angle A = ?$

By sine formula  $\frac{a}{\sin A} = \frac{b}{\sin B} = \frac{2b}{\sin C}$

$$\Rightarrow 2 \sin B = \sin C = \sin \left( B + \frac{\pi}{3} \right)$$

$$\Rightarrow 2 \sin B = \sin C = \sin \left( B + \frac{\pi}{3} \right)$$

$$\Rightarrow 2 \sin B = (\sin B) \frac{1}{2} + (\cos B) \frac{\sqrt{3}}{2}$$

$$\Rightarrow 4 \sin B = \sin B + \sqrt{3} \cos B$$

$$\Rightarrow \tan B = 1/\sqrt{3} \quad \Rightarrow \angle B = \pi/6$$

$$\Rightarrow \angle C = \pi/2 \quad \Rightarrow \angle A = \pi/3$$

3.108 > Trigonometry

2. (a)  $\angle B = \pi/8, \angle C = 5\pi/8 : AD = h; h : a ?$   
 $\Rightarrow \angle A = \pi - \left(\frac{\pi}{8} + \frac{5\pi}{8}\right) = \frac{\pi}{4}$

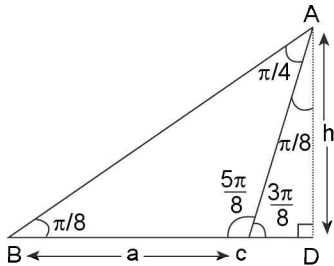

$\Rightarrow \angle CAD = \pi/8$  and  $\angle ACD = 3\pi/8$

In  $\triangle ABC, \frac{a}{\sin \frac{\pi}{4}} = \frac{b}{\sin \frac{\pi}{8}} \Rightarrow b = \frac{a}{\sin \frac{\pi}{4}} \left(\sin \frac{\pi}{8}\right)$

and in  $\triangle ACD, \frac{h}{\sin \frac{3\pi}{8}} = \frac{b}{\sin \frac{\pi}{2}}$

$\Rightarrow \frac{h}{\sin \frac{3\pi}{8}} = \sqrt{2} a \sin \frac{\pi}{8} \Rightarrow \frac{h}{a} = \sqrt{2} \sin \frac{\pi}{8} \sin \frac{3\pi}{8} = \frac{1}{2}$

Thus  $h : a = 1 : 2$ .

3. (d) By sine formula,  $\frac{a}{\sin A} = \frac{b}{\sin B} = \frac{c}{\sin C} = 2R$  .....(i)

- (a) Knowing  $a, \sin A, \sin B; b, \sin C$  and  $C$  can be determined and hence uniquely determine a  $\triangle ABC$ .  
 (b) Clearly  $a, b, c$ , uniquely determine a  $\triangle ABC$ .  
 (c) Knowing  $a$  and  $R$  gives  $\sin A$  and hence  $\angle A$ . Since  $\sin B$  is given,  $\angle C$  can be determined. Finally  $b$  and  $c$  can be determined.  
 (d) Knowing  $a, \sin A$  and  $R$  is not sufficient to determine the other components i.e.,  $b, c$  and  $\angle B, \angle C$ .

4. (d)  $s = 15$

$\therefore \sum (b+c) \cos(B+C)$   
 $= \sum (b+c) \cos(\pi - A) = -\sum (b+c) \cos A$   
 $= -[(b+c) \cos A + (a+c) \cos B + (a+b) \cos C]$   
 $= -[(a \cos B + b \cos A) + (b \cos C + c \cos B) + (c \cos A + a \cos C)] = -[c + a + b] = -2s = -(30)$

5. (c)  $\frac{a}{\cos A} = \frac{b}{\cos B}$

$\Rightarrow \sin A \cos B - \cos A \sin B = 0$   
 $\Rightarrow \sin(A - B) = 0 \Rightarrow A = B$   
 $\Rightarrow c = \pi - 2A$

- (a)  $2\sin A \sin B \sin C = 2\sin^2 A \sin 2A = 4 \sin^3 A \cos A \neq 1$   
 (b)  $\sin^2 A + \sin^2 B = 2\sin^2 A \neq \sin^2 C$  as  $\sin^2 C = \sin^2 2A$   
 (c)  $2\sin A \cos B = 2\sin A \cos A = \sin 2A = \sin C$

6. (d)  $a^2(\sin^2 B - \sin^2 C) + b^2(\sin^2 C - \sin^2 A) + c^2(\sin^2 A - \sin^2 B)$   
 $= \sum a^2(\sin^2 B - \sin^2 C)$

$= \sum a^2 \left( \frac{b^2}{4R^2} - \frac{c^2}{4R^2} \right) = \frac{1}{4R^2}$

$\sum a^2(b^2 - c^2) = \frac{1}{4R^2} [\sum a^2 b^2 - \sum a^2 c^2] = 0$

7. (c)  $\tan\left(\frac{A-B}{2}\right) = \frac{1}{3} \tan\left(\frac{A+B}{2}\right); a : b = ?$

$\Rightarrow \tan\left(\frac{A-B}{2}\right) = \frac{1}{3} \cot \frac{C}{2}$

$\Rightarrow \tan\left(\frac{A-B}{2}\right) \tan \frac{C}{2} = \frac{1}{3}$

$\Rightarrow \frac{a-b}{a+b} = \frac{1}{3} \Rightarrow \frac{2a}{-2b} = \frac{4}{-2} \Rightarrow \frac{a}{b} = \frac{2}{1}$

$\Rightarrow a : b = 2 : 1$

Had we taken  $\tan\left(\frac{B-A}{2}\right) = \frac{1}{3} \left(\frac{B+A}{2}\right)$

Then  $\frac{b}{a} = 2 : 1 \Rightarrow a : b = 1 : 2$

$\Rightarrow a : b = 1 : 2$  or  $2 : 1$

8. (a) Given  $a\left(\frac{s(s-c)}{ab}\right) + c\left(\frac{s(s-a)}{bc}\right) = \frac{3b}{2}$

Now, L.H.S.  $\frac{s}{b}(s-c) + \frac{s}{b}(s-a) = \frac{s}{b}[2s - (a+c)] = 3;$

R.H.S.  $= \frac{3b}{2}$

$\therefore s = \frac{3b}{2} \Rightarrow 2s = 3b \Rightarrow a + b + c = b$

$\Rightarrow a + c = 2b$

$\Rightarrow a, b, c$  are in A.P.

9. (c)  $\frac{a \cos A + b \cos B + c \cos C}{a + b + c}$

$= \frac{R \sin 2A + R \sin 2B + R \sin 2C}{R \sin A + 2R \sin B + 2R \sin C} = \frac{1}{2} \left[ \frac{4 \sin A \sin B \sin C}{4 \cos \frac{A}{2} \cos \frac{B}{2} \cos \frac{C}{2}} \right]$

$= \frac{1}{2} \left( 8 \sin \frac{A}{2} \sin \frac{B}{2} \sin \frac{C}{2} \right) = 4 \sin \frac{A}{2} \sin \frac{B}{2} \sin \frac{C}{2} = \frac{r}{R}$

10. (d)  $\sin C + \cos C + \sin(2B + C) - \cos(2B + C) = 2\sqrt{2}$

$\Rightarrow \sin C + \cos C + \sin(B + \pi - A) - \cos(B + \pi - A) = 2\sqrt{2}$

$\Rightarrow \sin C + \cos C + \sin(A - B) + \cos(A - B) = 2\sqrt{2}$

$\Rightarrow \sin(A + B) - \cos(A + B) + \sin(A - B) + \cos(A - B) = 2\sqrt{2}$

$\Rightarrow \sin(A + B) + \sin(A - B) + \cos(A - B) - \cos(A + B) = 2\sqrt{2}$

$\Rightarrow 2\sin A \cos B + 2\sin A \sin B = 2\sqrt{2}$

$\Rightarrow \sin A (\cos B + \sin B) = \sqrt{2}$

$\Rightarrow \sin A \left( \cos B \cdot \frac{1}{\sqrt{2}} + \sin B \cdot \frac{1}{\sqrt{2}} \right) = 1$

$\Rightarrow \sin A \cdot \cos(B - \pi/4) = 1$   
 $\Rightarrow \sin A = 1; \cos(B - \pi/4) = 1$   
 $\Rightarrow A = \pi/2; B = \pi/4; c = \pi/4$   
 $\Rightarrow \Delta ABC$  is isosceles and right angled.

11. (b)  $2ac \sin\left(\frac{A-B+C}{2}\right) = 2ac \sin\left[\frac{A+C}{2} - \frac{B}{2}\right]$   
 $= 2ac \sin\left(\frac{\pi}{2} - B\right) = 2ac \cos B = a^2 + c^2 - b^2$

12. (d) Given  $R = c = b$ ;  
 $\therefore$  By sine formula,  $\frac{a}{\sin A} = \frac{R}{\sin B} = \frac{R}{\sin C} = 2R$   
 $\Rightarrow \sin B = \sin C = 1/2 \Rightarrow A = \frac{2\pi}{3}$

13. (a)  $c = b; \angle A = 20^\circ; a^3 + b^3 = ? \Rightarrow \angle B = \angle C = 80^\circ$

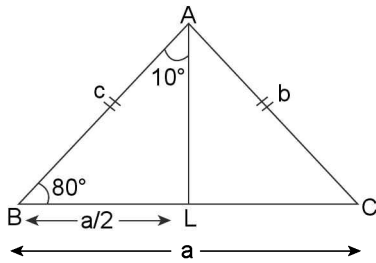

In  $\Delta ABL$ ,  $\sin 10^\circ = \frac{a}{2c} = \frac{a}{2b}$

$\Rightarrow a = 2b \sin 10^\circ$  .....(i)

Now  $a^3 + b^3 = 8b^3 \sin^3 10^\circ + b^3 = b^3 (8\sin^3 10^\circ + 1)$  .....(ii)

Now  $\sin 3\theta = 3 \sin \theta - 4 \sin^3 \theta$

$\Rightarrow 4\sin^3 \theta = 3 \sin \theta - \sin 3\theta$

$\therefore$  For  $\theta = 10^\circ$

$\Rightarrow 4\sin^3 10^\circ = 3 \sin 10^\circ - \sin 30^\circ$

$\Rightarrow 8\sin^3 10^\circ = 6 \sin 10^\circ - 1$

$\Rightarrow 8\sin^3 10^\circ + 1 = 6 \sin 10^\circ$  .....(iii)

Using (iii) in (ii), we get

$a^3 + b^3 = b^3 (6 \sin 10^\circ) = 6b^3 \left(\frac{a}{2b}\right)$  ..... (Using (i))

$= 3ab^2 = 3ac^2$

14. (c)  $\cot \alpha = \frac{R}{h_1} \Rightarrow h_1 = \frac{R}{\cot \alpha}$

$\Rightarrow h_1 = \frac{1}{\left[\frac{\cot \alpha}{R}\right]}$

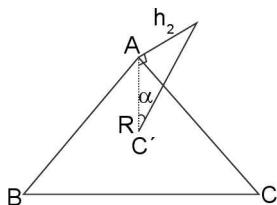

Similarly  $h_2 = \frac{1}{\left[\frac{\cot \beta}{R}\right]}$  and  $h_3 = \frac{1}{\left[\frac{\cot \gamma}{R}\right]}$ . Since  $\cot \alpha, \cot \beta, \cot \gamma$  are in AP.

$\Rightarrow \frac{\cot \alpha}{R}, \frac{\cot \beta}{R}, \frac{\cot \gamma}{R}$  are in A.P.

$\Rightarrow h_1, h_2, h_3$  are in H.P.

15. (b) Let PM be the height with P as its foot. Then  
 $\tan \alpha = \frac{h}{BP} = \frac{h}{AP} = \frac{h}{CP}$  .....(i)

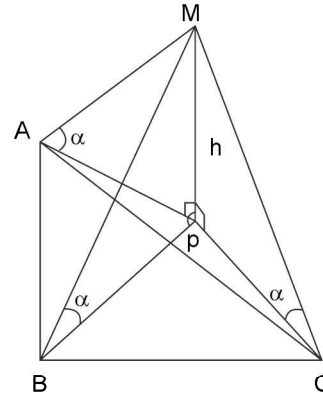

$\Rightarrow AP = BP = CP$

$\Rightarrow P$  is the circumcentre of  $\Delta ABC$

$\Rightarrow AP = BP = CP = R$  (circum radius)

$\therefore$  From (i),  $h = BP \tan \alpha = R \tan \alpha$

$\Rightarrow h = \frac{a}{2 \sin A} \tan \alpha = \frac{b}{2 \sin B} \tan \alpha = \frac{c}{2 \sin C} \tan \alpha$

$\Rightarrow h = \frac{a}{2} \tan \alpha \operatorname{cosec} A = \frac{b}{2} \tan \alpha \operatorname{cosec} B = \frac{c}{2} \tan \alpha \operatorname{cosec} C$

16. (b) In  $\Delta ABD$   $\frac{a}{2 \sin \alpha} = \frac{AD}{\sin B}$  .....(i)

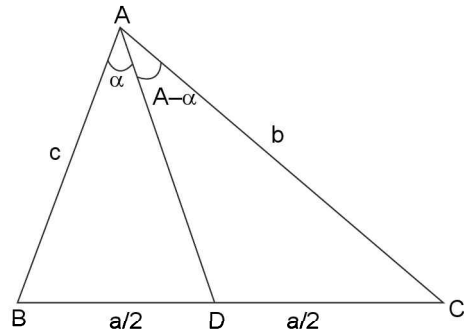

And in  $\Delta ACD$   $\frac{a}{2 \sin(A - \alpha)} = \frac{AD}{\sin C}$  .....(ii)

$\therefore$  from (ii),  $\sin(A - \alpha) = \frac{a \sin C}{2 \cdot AD}$  .....(iii)

Now from (i),  $AD = \frac{a \sin B}{2 \sin \alpha}$  .....(iv)

Using (iv) in (iii) we get,  $\sin(A - \alpha) = \frac{\sin C}{\sin B} \sin \alpha = \frac{c}{b} \sin \alpha$

3.110 > Trigonometry

17. (c)  $a^2 \sin 2B + b^2 \sin 2A = 2a^2 \sin B \cos B + 2b^2 \sin A \cos A =$   
 $\frac{2a^2 b}{2R} \cos B + \frac{2b^2}{2R} \cos A$   
 $= \frac{1}{R} ab (a \cos B + b \cos A) = \frac{1}{R} (abc)$   
 $\left[ \because \Delta = \frac{abc}{4R} = \lambda \right]$   
 $= 4\lambda$

18. (a)  $\frac{s}{R} = \frac{a+b+c}{2R} = \frac{a}{2R} + \frac{b}{2R} + \frac{c}{2R} = \sin A + \sin B + \sin C$

19. (d)  $a : b : c = 4 : 5 : 6$   
 $\Rightarrow \sin A : \sin B : \sin C = 4 : 5 : 6$   
 Let  $\sin A = 4k$ ,  $\sin B = 5k$  and  $\sin C = 6k$   
 Now, we are to evaluate  $R/r = \frac{abc / 4\Delta}{\Delta / s} = \frac{abc}{4\Delta^2} (s)$   
 $= \frac{abc s}{4s(s-a)(s-b)(s-c)} = \frac{abc}{4(s-a)(s-b)(s-c)}$   
 $= \frac{4 \times 5 \times 6}{4 \times \frac{7}{2} \times \frac{5}{2} \times \frac{3}{2}} = \frac{16}{7} = 16 : 7$

20. (b)  $\tan \frac{A}{2} \cdot \tan \frac{C}{2} = \frac{1}{3}$   
 $\Rightarrow \sqrt{\frac{(s-b)(s-c)}{s(s-a)}} \times \sqrt{\frac{(s-a)(s-b)}{s(s-c)}} = \frac{1}{3}$   
 $\Rightarrow \frac{s-b}{s} = \frac{1}{3} \Rightarrow a + c = 2b$   
 $\Rightarrow a, b, c$  are in A.P.

21. (a)  $\angle C = 60^\circ, \angle A = 75^\circ, \angle B = 40^\circ$

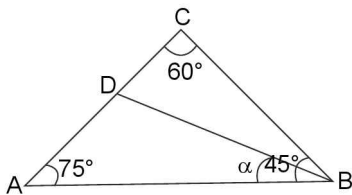

Given: area of  $\Delta BAD = \sqrt{3}$  (area of  $\Delta BCD$ )

$\Rightarrow \frac{1}{2} AD = \frac{1}{2} (DC) \sqrt{3}$   
 $\Rightarrow \frac{AD}{DC} = \frac{\sqrt{3}}{1} \dots (i)$

By sine formula, In  $\Delta ABD$ ,  $\frac{AD}{DB} = \frac{\sin \alpha}{\sin 75^\circ} \dots (ii)$

And in  $\Delta BCD$ ,  $\frac{DC}{DB} = \frac{\sin(45^\circ - \alpha)}{\sin 60^\circ} \dots (iii)$

$\therefore$  From (i), (ii), (iii) we get,  $\frac{\sqrt{3}}{1} = \frac{\sin \alpha}{\sin 75^\circ} \times \frac{\sin 60^\circ}{\sin(45^\circ - \alpha)}$

$\Rightarrow \sin a = 2 \sin 75^\circ \sin(45^\circ - a) = \cos(30^\circ + a) - \cos(120^\circ - a)$

$\Rightarrow \sin a = \sqrt{3} \cos a$  (on simplification)  
 $\Rightarrow a = \pi/6 \Rightarrow \angle ABD = 30^\circ$

22. (b)  $b + c = 3a$   
 $\Rightarrow 2s = 4a \dots (i)$   
 Now  $\cot \frac{B}{2} \cdot \cot \frac{C}{2} = \frac{s}{s-a} = \frac{2s}{2s-2a} = \frac{4a}{2a} = 2$

23. (b)  $\angle A = 2\pi/3; b - c = 3\sqrt{3};$  Area of  $DABC = \frac{9\sqrt{3}}{2}$

$\Rightarrow \frac{1}{2} (bc) \sin A = \frac{9\sqrt{3}}{2} \Rightarrow \frac{1}{2} bc \left( \sin \frac{2\pi}{3} \right) = \frac{9\sqrt{3}}{2}$

$\Rightarrow bc \left( \frac{\sqrt{3}}{2} \right) = 9\sqrt{3} \Rightarrow bc = 18$

Now,  $\cos A = \frac{b^2 + c^2 - a^2}{2bc}$

$\Rightarrow \frac{-1}{2} = \frac{(b-c)^2 + 2bc - a^2}{2bc}$

$\Rightarrow -18 = (3\sqrt{3})^2 + 2(18) - a^2$   
 $\Rightarrow a = 9$

24. (c) To find  $\angle C = ?; AC = 4p$

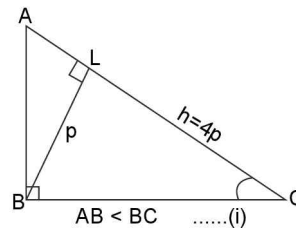

$\Rightarrow AL + LC = 4p$   
 $\Rightarrow p \cot A + p \cot C = 4p$   
 $\Rightarrow \cot A + \cot C = 4$   
 $\Rightarrow \cot \left( \frac{\pi}{2} - C \right) + \cot C = 4$   
 $\Rightarrow \frac{1}{2 \sin C \cos C} = \frac{4}{2}$   
 $\Rightarrow \sin 2C = 1/2$

$\Rightarrow 2C = \frac{\pi}{6}$  or  $\frac{5\pi}{6}$  (as  $2C \in (0, 2\pi)$ )

$\Rightarrow C = \frac{\pi}{12}$  or  $\frac{5\pi}{12}$   
 If  $C = \pi/12; A = 5\pi/12$  and if  $C = 5\pi/12; A = \pi/12$   
 But  $AB < BC \Rightarrow C < A$   
 $\Rightarrow C = \pi/12$

25. (b) In  $\Delta ABD$ ,  $\frac{BD}{\sin \alpha} = \frac{AD}{\sin 90^\circ} \dots (i)$

And  $\frac{DC}{\sin(45^\circ - \alpha)} = \frac{AD}{\sin 45^\circ} \dots (ii)$

From (i) and (ii), we get,  $\sin a = \sin(45^\circ - a) \cdot \sqrt{2}$

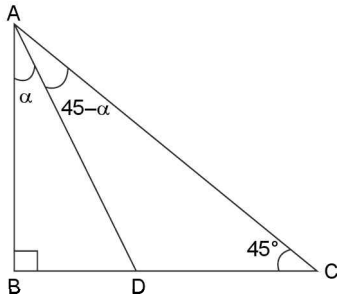

$$\Rightarrow \frac{\sin \alpha}{\sin(45^\circ - \alpha)} = \sqrt{2} \Rightarrow \frac{\sin \angle BAD}{\sin \angle CAD} = \frac{\sqrt{2}}{1}$$

26. (c)  $(a + b + c)(b + c - a) = k(bc)$

$$\Rightarrow (2s)(2s - 2a) = k(bc)$$

$$\Rightarrow 4s(s - a) = k(bc)$$

$$\Rightarrow \frac{s(s - a)}{bc} = \frac{k}{4} \Rightarrow \cos^2\left(\frac{A}{2}\right) = \frac{k}{4}$$

$$\Rightarrow \frac{k}{4} \in (0, 1)$$

$$\Rightarrow 0 < k < 4$$

27. (a)  $\left(1 - \frac{r_1}{r_2}\right)\left(1 - \frac{r_1}{r_3}\right) = 2$

$$\Rightarrow \left[1 - \frac{(s-b)}{(s-a)}\right]\left[1 - \frac{(s-c)}{(s-a)}\right] = 2$$

$$\Rightarrow \left[\frac{b-a}{s-a}\right]\left[\frac{c-a}{s-a}\right] = 2$$

$$\Rightarrow \left[\frac{2b-2a}{b+c-a}\right]\left[\frac{2c-2a}{b+c-a}\right] = 2$$

$$\Rightarrow 2(b-a)(c-a) = (b+c-a)^2$$

$$\Rightarrow b^2 + c^2 - a^2 = 0 \text{ (on simplification)}$$

$$\Rightarrow \angle A = \pi/2$$

28. (b)  $\frac{a \cos A + b \cos B + c \cos C}{a \sin B + b \sin C + c \sin A} = \frac{a + b + c}{9R}$

$$\Rightarrow \frac{\sum 2R \sin A \cos A}{\sum 2R \sin A \sin B} = \frac{2R(\sin A + \sin B + \sin C)}{9R}$$

$$\Rightarrow \frac{\sum \sin 2A}{2 \sum \sin A \sin B} = \frac{2}{9} \sum \sin A$$

$$\Rightarrow \frac{4 \sin A \sin B \sin C}{2 \sum \sin A \sin B} = \frac{2}{9} \sum \sin A$$

$$\Rightarrow \frac{2}{\sum \left(\frac{1}{\sin A}\right)} = \frac{2}{9} \sum \sin A$$

$$\Rightarrow \frac{3}{\sum \left(\frac{1}{\sin A}\right)} = \frac{\sum \sin A}{3}$$

$\Rightarrow$  H.M. of  $\sin A, \sin B, \sin C =$  A.M. of  $\sin A, \sin B, \sin C$

$\Rightarrow \sin A = \sin B = \sin C \Rightarrow A = B = C = \pi/3$

$\Rightarrow \Delta ABC$  is an equilateral  $\Delta$ .

29. (a)  $r_1 > r_2 > r_3 \Rightarrow \frac{\Delta}{(s-a)} > \frac{\Delta}{(s-b)} > \frac{\Delta}{(s-c)}$

$$\Rightarrow \frac{2}{(b+c-a)} > \frac{2}{(c+a-b)} > \frac{2}{(a+b-c)}$$

$$\Rightarrow (b+c-a) < c+a-b < a+b-c$$

$$\Rightarrow b < a \text{ and } c < b$$

$$\therefore c < b < a$$

30. (b)  $a = 3k, b = 4k, c = 5k$

$$\Rightarrow \frac{r}{4R} = \frac{\Delta/s}{abc/\Delta} = \frac{\Delta}{s} \times \frac{\Delta}{abc} = \frac{(s-a)(s-c)(s-b)}{abc}$$

$$= \frac{3 \times 2 \times 1}{3 \times 4 \times 5} = \frac{1}{10}$$

$$\Rightarrow 10r = 4R$$

$$\Rightarrow 5r = 2R \Rightarrow r = \frac{2R}{5}$$

31. (c)  $\frac{r}{r_1} = \frac{r_2}{r_3} \Rightarrow \frac{\frac{\Delta}{s}}{\frac{\Delta}{s-a}} = \frac{\frac{\Delta}{s-b}}{\frac{\Delta}{s-c}} \Rightarrow \frac{s-a}{s} = \frac{s-c}{s-b}$

$$\Rightarrow ab + s^2 - (a+b)s = s^2 - cs$$

$$\Rightarrow ab = (a+b-c)s \Rightarrow 2ab = (a+b)^2 - c^2$$

$$\Rightarrow a^2 + b^2 = c^2 \Rightarrow \angle C = 90^\circ$$

32. (c) Area of  $\Delta = \frac{1}{2}ax = \frac{1}{2}by = \frac{1}{2}cz$

$$\Rightarrow 2D = ax = by = cz \Rightarrow x = \frac{2\Delta}{a}, y = \frac{2\Delta}{b}, z = \frac{2\Delta}{c}$$

Since  $x, y, z$  are in A.P.

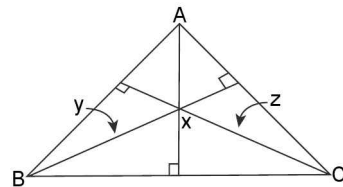

$$\Rightarrow \frac{2R}{\sin A}, \frac{2R}{\sin B}, \frac{2R}{\sin C} \text{ are in A.P.}$$

$$\Rightarrow \frac{1}{\sin A}, \frac{1}{\sin B}, \frac{1}{\sin C} \text{ are in A.P.}$$

$$\Rightarrow \sin A, \sin B, \sin C \text{ are in H.P.}$$

33. (c)  $\cos A, 1 - \cos B, \cos C$  are in A.P. ....(i)

And  $\sin A + \sin C = 1$  ....(ii)

Now  $2(1 - \cos B) = \cos A + \cos C$

$$\Rightarrow \left(4 \sin^2 \frac{B}{2}\right) = 2 \cos \frac{A+C}{2} \cos \frac{A-C}{2} \dots(\text{iii})$$

And from (ii), we get,  $1 = 2 \sin\left(\frac{A+C}{2}\right) \cos\left(\frac{A-C}{2}\right) \dots(\text{iv})$



3.112 > Trigonometry

Equation (iii)+(iv) gives  $4\sin^2 \frac{B}{2} = \cot\left(\frac{A+C}{2}\right)$

- $\Rightarrow 4\sin^2 B/2 = \tan B/2$
- $\Rightarrow 4 \sin B/2 \cdot \cos B/2 = 1 \Rightarrow \sin B = 1/2$
- $\Rightarrow B = \pi/6$  or  $5\pi/6$ . But  $\triangle ABC$  is acute angled.
- $\Rightarrow B = \pi/6$

34. (c) Given: ABCD is a square with each side: a (say)  
Such that  $\angle APC = \pi/2$ . To find  $\angle BPC = \theta$  (say) = ?

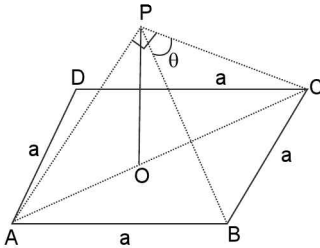

By symmetry, clearly  $AP = CP = BP = k$  (say), then in right  $\triangle APC$ ,  $2k^2 = 2a^2$

- $\Rightarrow k = a$  ... (i)
- Thus  $\triangle PBC$  is equilateral  $\triangle$  with each side = a
- $\Rightarrow \angle BPC = \theta = \pi/3$

35. (a) In  $\triangle ABP$ ,  $\cot 45^\circ = a/9 \Rightarrow a = 9$  ... (i)  
And in right  $\triangle ACP$ ,  $\cot 30^\circ = \frac{AC}{AP}$

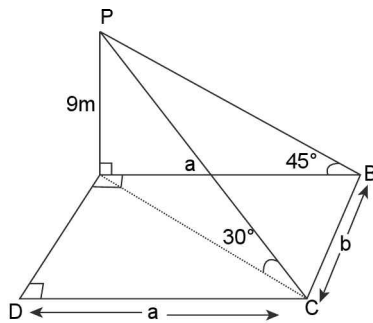

$\Rightarrow \sqrt{3} = \frac{\sqrt{a^2 + b^2}}{9} \Rightarrow \sqrt{3} = \frac{\sqrt{(9)^2 + b^2}}{9}$

$\Rightarrow b = 9\sqrt{2}$

$\therefore$  Area of rectangular field ABCD =  $ab = 81\sqrt{2} \text{ m}^2$

36. (d) Clearly roots of cubic equation  $x^3 - 11x^2 + 38x - 40 = 0$  are 2, 4 and 5.

So let  $a = 2$ ,  $b = 4$  and  $c = 5$

$\therefore \frac{\cos A}{2} + \frac{\cos B}{4} + \frac{\cos C}{5}$   
 $= \left(\frac{b^2 + c^2 - a^2}{4bc}\right) + \left(\frac{a^2 + c^2 - b^2}{8ac}\right) + \left(\frac{a^2 + b^2 - c^2}{10ab}\right)$   
 $= \frac{37}{80} + \frac{13}{80} - \frac{5}{80} = \frac{9}{16}$

37. (a) Clearly D is the mid point of EF, with  $ED = DF = a/4$  and  $EF = a/2$

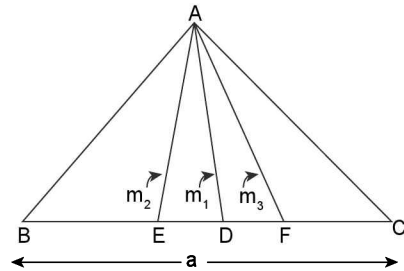

We know that length of median from vertex A is given

by  $\ell = \frac{1}{2}\sqrt{2b^2 + 2c^2 - a^2}$

$\therefore m_1 = \frac{1}{2}\sqrt{2m_2^2 + 2m_3^2 - (EF)^2}$

$\Rightarrow m_1 = \frac{1}{2}\sqrt{2m_2^2 + 2m_3^2 - \left(\frac{a}{2}\right)^2}$

$\Rightarrow 4m_1^2 = 2m_2^2 + 2m_3^2 - \frac{a^2}{4}$

$\Rightarrow \frac{a^2}{8} = m_2^2 + m_3^2 - 2m_1^2$

38. (c) In right  $\triangle ABL$ ,  $\cos B = \frac{BL}{AB} \Rightarrow BL = c \cos B$  ... (i)

Now, in right  $\triangle BLH$ ,  $\cot C = HL/BL$

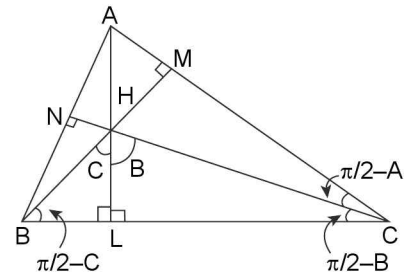

$\Rightarrow HL = BL \cot C = c \cos B \cot C$

$\Rightarrow HL = 2R \cos B \cos C$

Similarly  $HM = 2R \cos C \cos A$  and  $HN = 2R \cos A \cos B$

$\therefore HL : HM : HN = \sec A : \sec B : \sec C$

39. (b)  $\cot A \cdot \cot B \cdot \cot C > 0 \Rightarrow \cot A, \cot B, \cot C > 0$ , or any two of  $\cot A, \cot B$  and  $\cot C$  are negative and the third one is positive

$\Rightarrow$  Either each of A, B and C are acute angles or any two of A, B and C are obtuse and the third one is acute, But the later case is impossible as in a triangle two angles can't be obtuse. Thus the triangle must be an acute angled triangle.

40. (b) Let the sides  $a = b - 2k$ ;  $c = b - k$ , then  $a, c, b$  are in A.P.

Now,  $\cos B = \frac{a^2 + c^2 - b^2}{2ac}$

$\Rightarrow \frac{1}{2} = \frac{(7-2k)^2 + (7-k)^2 - 49}{2(7-2k)(7-k)}$

$\Rightarrow -(7-2k)(7-k) = (7-2k)^2 + (7-k)^2 - 49 = 0$   
 $\Rightarrow k = 2$  or  $k = 7$

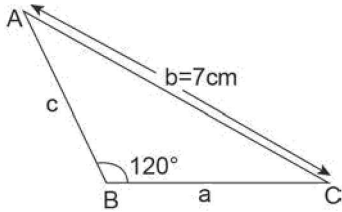

But for  $k = 7, c = 0 \therefore k = 2$

$\therefore a = 3, b = 7, c = 5$

$\therefore$  Area of  $\triangle ABC = \frac{1}{2} a c \sin 120^\circ = \frac{1}{2} (15) \sin 60^\circ = \frac{15\sqrt{3}}{4}$   
 square cm

41. (d)  $PQ = PR = R$  (radius of circum-circle)

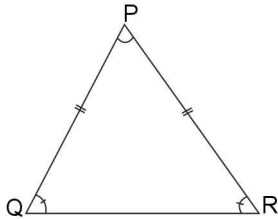

By sine formula  $\frac{R}{\sin R} = \frac{R}{\sin Q} = 2R$

$\Rightarrow \sin R = \sin Q = 1/2 \Rightarrow \angle R = \angle Q = \pi/6$

$\Rightarrow \angle P = 2\pi/3$

42. (c) Now,  $b = AL + CL \Rightarrow 2\sqrt{2} p \cot A + p \cot C$

$\Rightarrow 2\sqrt{2} = \cot A + \cot C$

$\Rightarrow 2\sqrt{2} = \frac{\cos A}{\sin A} + \frac{\cos C}{\sin C}$

$\Rightarrow 2\sqrt{2} = \frac{\sin C \cos A + \cos C \sin A}{\sin A \sin C}$

$\Rightarrow 2\sqrt{2} \sin A \sin C = \sin(A + C)$

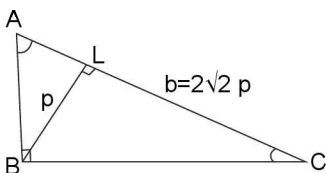

$\Rightarrow 2\sqrt{2} \sin A \sin C = \sin B$

$\Rightarrow 2\sqrt{2} \sin A \sin C = 1 \Rightarrow 2 \sin A \sin C = 1/\sqrt{2}$

$\Rightarrow \cos(A - C) - \cos(A + C) = 1/\sqrt{2}$

$\Rightarrow \cos(A - C) + \cos B = 1/\sqrt{2}$

$\Rightarrow \cos(A - C) = 1/\sqrt{2} \Rightarrow A - C = \pm \pi/4$

$\Rightarrow A - C = \pi/4$

Also  $A + C = \pi/2 \Rightarrow A = 3\pi/8; C = \pi/8$

By taking  $A - C = -\pi/4$ ; we get  $A = \pi/8; C = 3\pi/8$

43. (c)  $(a - b)^2 + (b - c)^2 + (c - a)^2 \geq 0$

$\Rightarrow 2(a^2 + b^2 + c^2) \geq 2ab + 2bc + 2ca \dots(i)$

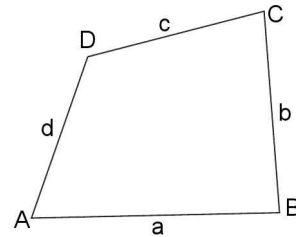

$\Rightarrow 3(a^2 + b^2 + c^2) \geq (a + b + c)^2 > d^2$

$\Rightarrow \frac{a^2 + b^2 + c^2}{d^2} > \frac{1}{3}$

$\Rightarrow$  The value of  $\frac{a^2 + b^2 + c^2}{d^2}$  is always greater than 1/3.

44. (b)  $b.c = k^2 \Rightarrow \cos A = \frac{b^2 + c^2 - a^2}{2bc}$

$\Rightarrow \cos A = \frac{b^2 + c^2 - a^2}{2k^2}$

$\Rightarrow a^2 = b^2 + c^2 - 2k^2 \cos A \geq 2bc - 2k^2 \cos A$

(By A.M  $\geq$  G.M)

$\Rightarrow a^2 \geq 2k^2 - 2k^2 \cos A$

$\Rightarrow a^2 \geq 2k^2 (2\sin^2 A/2)$

$\Rightarrow a \geq 2k \sin A/2$

45. (b)  $r_1 = 3, r_2 = 4, r_3 = 6 = r = ?$

$\therefore \frac{1}{r_1} + \frac{1}{r_2} + \frac{1}{r_3} = \frac{1}{r} \Rightarrow \frac{1}{3} + \frac{1}{4} + \frac{1}{6} = \frac{1}{r}$

$\Rightarrow r = 4/3$

46. (c) Here  $r = 4 \Rightarrow R = 8$

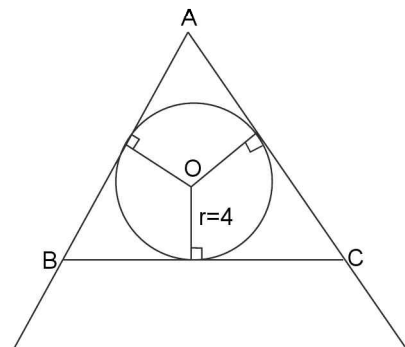

3.114 > Trigonometry

$$\therefore a = 2\sin A = 2(8) \sin 60^\circ = 16 \left( \frac{\sqrt{3}}{2} \right) = 8\sqrt{3}$$

$$\text{Now, } r_1 = s \tan \frac{A}{2} = 12\sqrt{3} \left( \frac{1}{\sqrt{3}} \right) = 12$$

\(\therefore\) Area of drawn circle =  $144\pi$  square units.

47. (a) \(\because\)  $\sin 2A + \sin 2B + \sin 2C = 4 \sin A \sin B \sin C$  and  $\angle C = 90^\circ$   
 $\Rightarrow \sin 2A + \sin 2B = 4 \sin A \sin B$

$$\Rightarrow \sin A \cdot \sin B = 1/4 (\sin 2A + \sin 2B) \leq \frac{2}{4} = \frac{1}{2}$$

And attains for  $A = B = \pi/4$

48. (b)  $\frac{1}{2}ap_1 = \frac{1}{2}bp_2 = \frac{1}{2}cp_3$

$$\Rightarrow \frac{1}{p_1} + \frac{a}{2\Delta}; \frac{1}{p_2} = \frac{b}{2\Delta}; \frac{1}{p_3} = \frac{c}{2\Delta}$$

$$\Rightarrow \frac{1}{p_1} + \frac{1}{p_2} + \frac{1}{p_3} = \frac{s}{\Delta}$$

49. (b) In  $\Delta O'BC$ ,  $\frac{a}{\sin(\pi - A)} = \frac{R}{\sin \frac{A}{2}}$

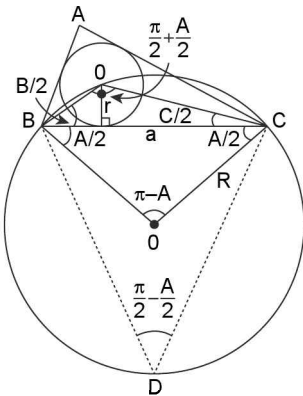

$$\Rightarrow R = \frac{a \sin \frac{A}{2}}{\sin A} = \frac{a}{2} \sin \frac{A}{2}$$

50. (a)  $AB_1 = c_1; AB_2 = c_2$

$$\text{Area of } \Delta ACB_1 + \text{area of } \Delta ACB_2 = \frac{1}{2}c_1 h + \frac{1}{2}c_2 h =$$

$$\frac{1}{2}(c_1 + c_2)h = \frac{1}{2}(c_1 + c_2) \cdot b \sin A \quad \dots\dots(i)$$

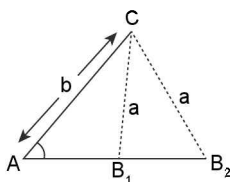

$$\text{Now } \cos A = \frac{b^2 + c^2 - a^2}{2bc}$$

$$\Rightarrow c^2 - (2b \cos A)c + (b^2 - a^2) = 0$$

$$\Rightarrow c_1 + c_2 = 2b \cos A \quad \dots\dots(ii)$$

$$\therefore \text{ from (i) and (ii), sum of areas} = \frac{1}{2}(2b \cos A)b \sin A = \frac{1}{2}b^2 \sin^2 A$$

51. (a) \(\because\)  $\tan^{-1} x + \tan^{-1} y = \tan^{-1} \left( \frac{x+y}{1-xy} \right)$

For  $xy < 1$

$$\text{Now } b < a + c \Rightarrow \frac{b}{a+c} < 1 \text{ and } \frac{c}{a+b} < 1$$

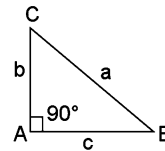

$$\Rightarrow \left( \frac{b}{a+c} \right) \left( \frac{c}{a+b} \right) < 1$$

$$\therefore \tan^{-1} \left( \frac{b}{a+c} \right) + \tan^{-1} \left( \frac{c}{a+b} \right)$$

$$= \tan^{-1} \left[ \frac{\frac{b}{a+c} + \frac{c}{a+b}}{1 - \frac{bc}{(a+c)(a+b)}} \right]$$

$$= \tan^{-1} \left[ \frac{ab + b^2 + ac + c^2}{a^2 + ab + ac + bc - bc} \right]$$

$$= \tan^{-1} \left[ \frac{ab + a^2 + ac}{a^2 + ab + ac} \right] \quad (\because c^2 + b^2 = a^2)$$

$$= \tan^{-1}(1) = \frac{\pi}{4}$$

52. (c)  $AD^2 + BE^2 + CF^2$

$$= \frac{1}{4} [2b^2 + 2c^2 - a^2 + 2a^2 + 2c^2 - b^2 + 2a^2 + 2b^2 - c^2]$$

$$= \frac{1}{4} [3a^2 + 3b^2 + 3c^2] = \frac{3}{4}(a^2 + b^2 + c^2)$$

$$\Rightarrow \frac{AD^2 + BE^2 + CF^2}{BC^2 + CA^2 + AB^2} = \frac{3}{4}$$

53. (c)  $\frac{a^2 + b^2 + c^2}{R^2} = 4 \left[ \left( \frac{a}{2R} \right)^2 + \left( \frac{b}{2R} \right)^2 + \left( \frac{c}{2R} \right)^2 \right] = 4 [\sin^2 A + \sin^2 B + \sin^2 C]$

$$= 4 \left[ \frac{1 - \cos 2A}{2} + \frac{1 - \cos 2B}{2} + \frac{1 - \cos 2C}{2} \right]$$

$$= 4 \left( \frac{3}{2} \right) - 2(\cos 2A + \cos 2B + \cos 2C) = 6 - 2 [-1 -$$

$$4 \cos A \cos B \cos C] = 8 + 8 \cos A \cos B \cos C$$

Now for maximum value  $\cos A, \cos B, \cos C$  must be positive.

∴ By G.M. ≤ A.M.

$$\Rightarrow (\cos A \cdot \cos B \cdot \cos C)^{1/3} \leq \left( \frac{\cos A + \cos B + \cos C}{3} \right) \text{ or}$$

$$\cos A \cos B \cos C \leq \left[ \frac{\cos A + \cos B + \cos C}{3} \right]^3$$

and maximum exists for  $A = B = C$

$$\Rightarrow \cos A \cdot \cos B \cdot \cos C \leq \frac{1}{8}$$

$$\Rightarrow 8 + 8 \cos A \cdot \cos B \cdot \cos C \leq 9$$

54. (c)  $\tan \theta = \frac{18}{x}$  ..... (i)

$$\tan\left(\frac{\pi}{2} - \theta\right) = \frac{6}{x}$$
 ..... (ii)

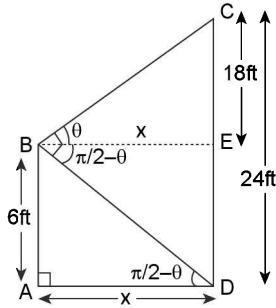

$$\Rightarrow \frac{18}{x} \times \frac{6}{x} = 1 \Rightarrow x = \sqrt{27 \times 4}$$

$$\Rightarrow x = 6\sqrt{3} \text{ ft}$$

55. (b)  $v = \frac{ds}{dt} = 2t + 3 \Rightarrow s = t^2 + 3t$

Now BC = Distance travelled by rocket in 1 second = 4m and BD = Distance travelled by rocket in 3 second = 18m.

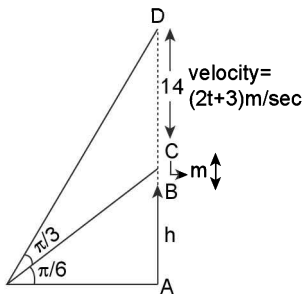

$$\Rightarrow CD = (18 - 4) = 14\text{m}$$

$$\therefore x = (h + 4) \cot \frac{\pi}{6} = (h + 18) \cot \frac{\pi}{3}$$

$$\Rightarrow x = (h + 4) \cdot \sqrt{3} = (h + 18) \frac{1}{\sqrt{3}}$$

$$\Rightarrow 3h + 12 = h + 18 \Rightarrow h = 3\text{m.}$$

$$\Rightarrow x = (h + 4) \cot \frac{\pi}{6} \Rightarrow x = 7\sqrt{3}\text{m.}$$

56. (a) Clearly above sectorial area is the lateral surface area of right circular cone.

$$\Rightarrow S = \frac{216}{360} \cdot \pi(10)^2 = 60\pi \text{ sq.cm.}$$

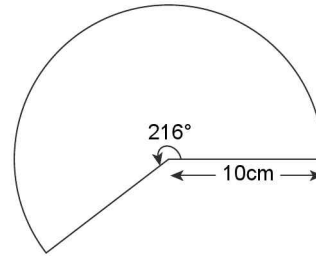

$$\Rightarrow \pi r l = 60\pi \Rightarrow r l = 60; \text{ ..... (i)}$$

$r$  = radius of cone,  $l$  = slant height of cone and given the semi-vertical angle  $\theta$

$$\Rightarrow \sin \theta = \frac{r}{l} \text{ ..... (ii)}$$

Clearly,  $l = 10 \text{ cm} \Rightarrow r = 6 \therefore \sin \theta = \frac{r}{l} = \frac{3}{5}$

57. (d) Clearly the pole must start at the centre of regular hexagon.

$R$  = radius of regular hexagon with each side 'a' is given by  $R = \frac{a}{2} \operatorname{cosec}\left(\frac{\pi}{n}\right); n = 6$  i.e.,  $R = \frac{a}{2} \operatorname{cosec}\left(\frac{\pi}{6}\right) = a$

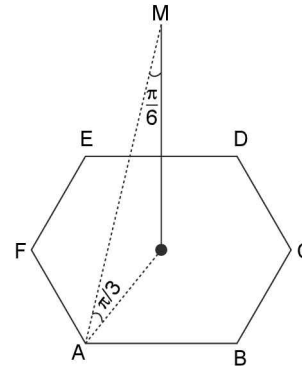

Now area of circum-circle =  $\pi R^2 = \pi a^2 = A$  (given)

$$\Rightarrow a = \sqrt{\frac{A}{\pi}}$$

$$\therefore \text{Area of hexagon} = 6 \left( \frac{\sqrt{3}}{4} a^2 \right) = 6 \left( \frac{\sqrt{3}}{4} \times \frac{A}{\pi} \right) = \frac{3\sqrt{3}}{2} \cdot \frac{A}{\pi}$$

58. (a) Here in  $\triangle DEF$ ;  $\tan \theta = \frac{DE}{EF} = \frac{2.5}{x}$  ..... (1)

Also in  $\triangle EDF$ ,  $\tan \theta = 1$

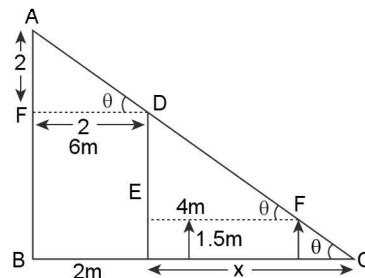

$$\Rightarrow x = 2.5 = \frac{5}{2}\text{m.}$$

59. (c)  $\cos \theta = \frac{(5)^2 + (5)^2 - (BC)^2}{2(5)(5)}$  .....(i)

Also  $BC = R = \frac{a}{2} \operatorname{cosec} \left( \frac{\pi}{n} \right)$

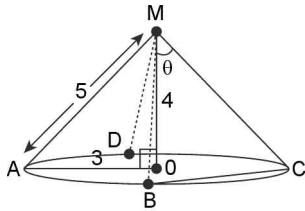

$\Rightarrow 3 = \frac{a}{2} \operatorname{cosec} \left( \frac{\pi}{4} \right) \Rightarrow a = \frac{6}{\sqrt{2}} = 3\sqrt{2}$

$\therefore$  From (i)  $\cos \theta = \frac{50 - 18}{50} = \frac{16}{25}$

60. (c)  $\tan \theta = \frac{h}{x}$  and  $\tan 2\theta = \frac{3h}{x}$

$\Rightarrow 2 \left( \frac{\frac{h}{x}}{1 - \frac{h^2}{x^2}} \right) = \frac{3h}{x}$

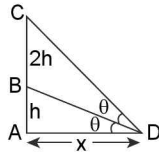

$\Rightarrow 2 \left[ \frac{hx}{x^2 - h^2} \right] = \frac{3h}{x} \Rightarrow 2x^2 = 3(x^2 - h^2)$

$\Rightarrow x^2 = 3h^2 \Rightarrow \frac{h}{x} = \frac{1}{\sqrt{3}}$

**SECTION-IV (MORE THAN ONE CORRECT ANSWER)**

1. (b, c)  $a = \sqrt{12}, b = \sqrt{8}$

i.e.,  $a = 2\sqrt{3}, b = 2\sqrt{2}$ , C be third side

Case (i): If b is the shortest side, then  $\angle B = 45^\circ$

$\therefore \frac{a}{\sin A} = \frac{b}{\sin B} = \frac{c}{\sin C}$

$\Rightarrow \sin A = \frac{a \sin B}{b} = \frac{2\sqrt{3}}{2\sqrt{2}} \times \frac{1}{\sqrt{2}} = \frac{\sqrt{3}}{2}$

$\Rightarrow A = 60^\circ \Rightarrow C = 75^\circ$

$\Rightarrow c = \frac{b \sin C}{\sin B} = \frac{2\sqrt{2} \sin 75^\circ}{(1/\sqrt{2})} = 4 \left( \frac{\sqrt{3} + 1}{2\sqrt{2}} \right) = \sqrt{6} + \sqrt{2}$

Case (ii): If C is the shortest side, then  $\angle C = 45^\circ$

$\Rightarrow \cos C = \frac{a^2 + b^2 - c^2}{2ab} \Rightarrow \frac{1}{\sqrt{2}} = \frac{12 + 8 - c^2}{2(2\sqrt{3})(2\sqrt{2})}$

$\Rightarrow 8\sqrt{3} = 20 - c^2 \Rightarrow c = \sqrt{20 - 8\sqrt{3}}$

2. (a, d)  $a = 10, b = 9; c =$  third side

$\therefore$  a and b are larger side

$\Rightarrow a > b > c \Rightarrow \angle A > \angle B > \angle C$

$\therefore \angle A, \angle B, \angle C$  are in AP. Let them be  $60^\circ + d, 60^\circ, 60^\circ - d$  respectively.

$\Rightarrow \cos B = \frac{a^2 + c^2 - b^2}{2ac} \Rightarrow \frac{1}{2} = \frac{100 + c^2 - 81}{2(10)(c)}$

$\Rightarrow 10c = 19 + c^2 \Rightarrow c^2 - 10c + 19 = 0$

$\Rightarrow c = \frac{10 \pm \sqrt{100 - 76}}{2} \Rightarrow c = 5 \pm \sqrt{6}$

3. (a, d) Length of median is given by  $\ell = \frac{1}{2} \sqrt{2b^2 + 2c^2 - a^2}$

or  $\ell = \frac{1}{2} \sqrt{b^2 + c^2 + 2bc \cos A}$

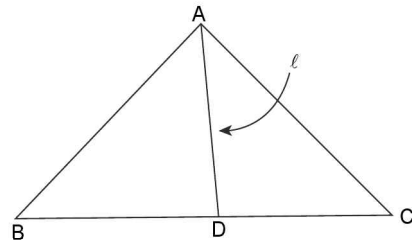

$\Rightarrow 4\ell^2 = 2b^2 + 2c^2 - a^2$  or  $4\ell^2 = b^2 + c^2 + 2bc \cos A$  or  $4\ell^2 = (b + c)^2 - 2bc + 2bc \cos A$  or  $4\ell^2 = (b + c)^2 - 2bc(1 - \cos A)$

$\Rightarrow 4\ell^2 = (b + c)^2 - 2bc \left( 2\sin^2 \frac{A}{2} \right)$

$\Rightarrow 4\ell^2 = (2s - a)^2 - 4bc \sin^2 A/2$

4. (a, d)  $\cos A = \frac{b^2 + c^2 - a^2}{2bc}$

$\Rightarrow 2bc \cos A = b^2 + c^2 - a^2$

$\Rightarrow c^2 - (2b \cos A) c + (b^2 - a^2) = 0$

$\Rightarrow c = \frac{2b \cos A \pm \sqrt{4b^2 \cos^2 A - 4(b^2 - a^2)}}{2}$

$\Rightarrow c = b \cos A \pm \sqrt{a^2 - b^2 \sin^2 A}$  .....(i),

Also  $\frac{a}{\sin A} = \frac{b}{\sin B} = \frac{c}{\sin C}$

$\Rightarrow \sin B = \frac{b \sin A}{a}$

Now, if  $a < b \sin A$ , then no triangle is possible

( $\therefore$  of(1))

$\Rightarrow$  (b) and (c) are impossible

Also if  $b \sin A = a \Rightarrow \sin B = 1$

$\Rightarrow \angle B = \pi/2 \Rightarrow \angle A < \pi/2$

$\Rightarrow$  (a) is possible

Now if  $a > b \sin A$ , then from (i),  $\Delta$  is possible and from

(ii)  $\sin B < 1 \Rightarrow \angle B \neq \pi/2$

If  $a < b \Rightarrow \angle A < \angle B$

$\Rightarrow \angle A$  is acute  $\Rightarrow \angle A < \pi/2$

5. (a, c) Let the sides be a, b, b  $\angle A = \alpha < \frac{\pi}{4}$

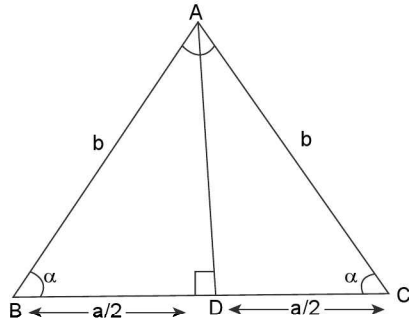

By sine formula,  $R = a/2 \operatorname{cosec} 2\alpha$ . But  $\frac{a}{2} = b \cos \alpha$

$$\Rightarrow R = b \cos \alpha \cdot \frac{1}{\sin 2\alpha}$$

$$\Rightarrow R = \frac{b}{2} \operatorname{cosec} \alpha \Rightarrow \text{(a) is correct}$$

Also  $\Delta = 1/2 b^2 \sin (180^\circ - 2\alpha) = b^2/2 \sin 2\alpha$

$$\text{Further } r = \frac{\Delta}{3} = \frac{\Delta}{(a+2b)} = \frac{\Delta}{2b \cos \alpha + 2b} = \frac{b^2 \sin 2\alpha}{4b(1 + \cos \alpha)}$$

$$\Rightarrow r = \frac{b \sin 2\alpha}{4(1 + \cos \alpha)}, \text{ which is option (c)}$$

6. (b, c) Let  $r_1$  and  $r_2$  be the radii of circles touching the given circles externally and internally respectively

$$\cos B = \frac{LB}{OB} = \frac{r}{r_1 + r}$$

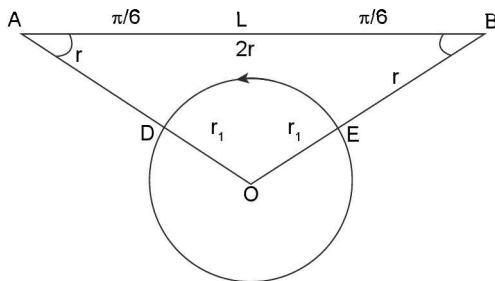
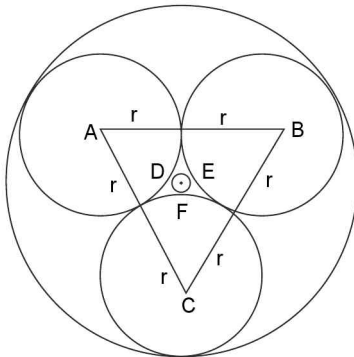

$$\Rightarrow \frac{\sqrt{3}}{2} = \frac{r}{r_1 + r} \Rightarrow r_1 + r = \frac{2r}{\sqrt{3}}$$

$$\Rightarrow r_1 = r \left( \frac{2 - \sqrt{3}}{\sqrt{3}} \right) \Rightarrow \text{(c) is the correct option}$$

$$\text{Again } r_2 = r_1 + 2r = \left( \frac{2 - \sqrt{3}}{\sqrt{3}} \right) r + 2r = \frac{(2 - \sqrt{3} + 2\sqrt{3})r}{\sqrt{3}}$$

$$= \left( \frac{2 + \sqrt{3}}{\sqrt{3}} \right) r \Rightarrow \text{(b) is the correct option}$$

7. (a, c, d)  $\frac{\sin A}{\sin C} = \frac{\sin(A-B)}{\sin(B-C)} \dots (i)$

$$\Rightarrow \frac{\sin(B+C)}{\sin(A+B)} = \frac{\sin(A-B)}{\sin(B-C)}$$

$$\Rightarrow \sin(B+C) \cdot \sin(B-C) = \sin(A-B) \cdot \sin(A+B)$$

$$\Rightarrow \sin^2 B - \sin^2 C = \sin^2 A - \sin^2 B$$

$$\Rightarrow \sin^2 A, \sin^2 B, \sin^2 C \text{ are in AP}$$

$$\Rightarrow \cos 2A, \cos 2B, \cos 2C \text{ are in AP}$$

$$\text{Also } \sin^2 A = \frac{a \sin A}{2R} \text{ etc.}$$

$$\Rightarrow a \sin A, b \sin B, c \sin C \text{ are in AP.}$$

$$\text{Also from (i), we get } \frac{\sin(B-C)}{\sin C} = \frac{\sin(A-B)}{\sin A}$$

$$\Rightarrow \frac{\sin(B-C)}{\sin B \sin C} = \frac{\sin(A-B)}{\sin A \sin B}$$

$$\Rightarrow \cot C - \cot B = \cot B - \cot A$$

$$\Rightarrow \cot A, \cot B, \cot C \text{ are in AP}$$

8. (c, d)  $\cos \beta = \frac{a^2 + c^2 - b^2}{2ac}$

$$\Rightarrow \frac{1}{2} = \frac{a^2 + c^2 - b^2}{2ac}$$

$$\Rightarrow ac = a^2 + c^2 - b^2 \dots (i)$$

$$\Rightarrow -ac = a^2 + c^2 - 2ac - b^2$$

$$\Rightarrow -ac = (c-a)^2 - b^2$$

$$\Rightarrow (c-a)^2 = b^2 - ac$$

$$\Rightarrow \text{option (c) is correct}$$

$$\text{Also from (i), } a^2 + c^2 + b^2 = 2b^2 + ac$$

9. (a, b, c, d)  $\tan A, \tan B$  are roots of equation  $abx^2 - c^2x + ab = 0$

$$\Rightarrow \tan A + \tan B = \frac{c^2}{ab} \text{ and } \tan A \cdot \tan B = 1$$

$$\Rightarrow \tan(A+B) = \infty$$

$$\Rightarrow A+B = \pi/2$$

$$\Rightarrow C = \pi/2$$

$$\Rightarrow \cot C = 0$$

$$\Rightarrow \tan A = a/b ; \tan B = b/a \text{ or } \tan A = b/a ; \tan B = a/b$$

10. (a, d)  $\tan \alpha = \frac{AB}{BM} = \frac{3h}{y} \dots (i)$

$$\text{and } \tan \left( \frac{\pi}{2} - \alpha \right) = \frac{FG}{MG} = \frac{h}{x}$$

3.118 > Trigonometry

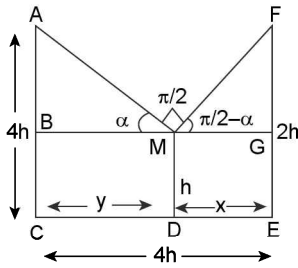

$$\Rightarrow \cot \alpha = \frac{h}{x} \quad \dots \text{(ii)}$$

$$\text{Also } x + y = 4h \quad \dots \text{(iii)}$$

$$\text{Equation (i)} \times \text{(ii) gives, } xy = 3h^2 \quad \dots \text{(iv)}$$

$\therefore$  from (iii) and (iv) we get,  $x = 3h, y = h$  or  $x = h, y = 3h$

$$\Rightarrow \frac{x}{y} = \frac{1}{3} \text{ or } \frac{3}{1}$$

11. (a, b, c),  $\therefore$  angles of  $\triangle ABC$  are in A.P.

$$\Rightarrow \frac{\pi}{3} - D, \frac{\pi}{3}, \frac{\pi}{3} + D$$

Will be the angles of  $\triangle ABC$ , a, b, c are in G.P.

$$\Rightarrow b^2 = ac$$

$$\text{Now } \cos \frac{\pi}{3} = \frac{a^2 + c^2 - b^2}{2ac}$$

$$\Rightarrow \frac{1}{2} = \frac{a^2 + c^2 - ac}{2ac} \Rightarrow a^2 + c^2 - 2ac = 0$$

$$\Rightarrow (a - c)^2 = 0 \Rightarrow a = c$$

$$\therefore b^2 = ac \Rightarrow b^2 = a^2$$

$$\Rightarrow b = a$$

$$\therefore a = b = c \Rightarrow a^2 = b^2 = c^2$$

$$\Rightarrow a^2, b^2, c^2 \text{ are in A.P. G.P. and H.P.}$$

**SECTION-V (ASSERTION AND REASON TYPE ANSWERS)**

1. (c) In a  $\triangle ABC$ ,  $\tan A + \tan B + \tan C = \tan A \cdot \tan B \cdot \tan C$

$$\Rightarrow k + 2k + 3k = k \cdot 2k \cdot 3k$$

$$\Rightarrow 6k^3 - 6k = 0$$

$$\Rightarrow k = 0 \text{ or } k = \pm 1$$

But for  $k = 0$  and  $k = -1$ , all angles are zeros or supplementary. So  $k = 1$

$$\Rightarrow \tan A = 1$$

$$\Rightarrow A = 45^\circ$$

$$\text{But } \alpha : \beta : \gamma = 1 : 2 : 3$$

$$\Rightarrow \alpha = 1$$

So, assertion is correct but reason incorrect.

2. (a) Let  $b = 2$  and  $c = 3$

$$\text{Then area of } \triangle ABC = \frac{1}{2} bc \sin A = 3 \sin A \leq 3$$

Thus area can't exceed 3.

$\therefore$  Assertion and reason are correct and reason correct explain the assertion.

3. (a)  $\because s - a, s - b, s - c$  are +ve &  $AM \geq GM$

$$\frac{a}{2} = \frac{s - b + s - c}{2} \geq \sqrt{(s - b)(s - c)} \quad \dots \text{(i)}$$

$$\frac{b}{2} = \frac{s - c + s - a}{2} \geq \sqrt{(s - c)(s - a)} \quad \dots \text{(ii)}$$

$$\frac{c}{2} = \frac{s - a + s - b}{2} \geq \sqrt{(s - a)(s - b)} \quad \dots \text{(iii)}$$

Multiplying three inequality, we get

$$\frac{abc}{8} \geq (s - a)(s - b)(s - c)$$

$$\frac{(a + b + c)}{16} abc \geq s(s - a)(s - b)(s - c)$$

$$\Rightarrow \frac{abc(a + b + c)}{16} \geq \Delta^2$$

$$\Rightarrow \frac{\sqrt{(a + b + c)abc}}{4} \geq \Delta$$

A is true & R as well Also R explains A

4. (d)  $\cos^2 \frac{A}{2} + \cos^2 \frac{B}{2} + \cos^2 \frac{C}{2}$

$$= \frac{1 + \cos A}{2} + \frac{1 + \cos B}{2} + \frac{1 + \cos C}{2}$$

$$= \frac{3}{2} + \frac{1}{2}(\cos A + \cos B + \cos C)$$

$$= \frac{3}{2} + \frac{1}{2} \left[ 1 + 4 \sin \frac{A}{2} \sin \frac{B}{2} \sin \frac{C}{2} \right]$$

$$= 2 + 2 \sin \frac{A}{2} \sin \frac{B}{2} \sin \frac{C}{2} \quad \dots \text{(i)}$$

$$\text{Also, } 0 < \sin \frac{A}{2} \cdot \sin \frac{B}{2} \cdot \sin \frac{C}{2} \leq \frac{1}{8}$$

$$\therefore \cos^2 \frac{A}{2} + \cos^2 \frac{B}{2} + \cos^2 \frac{C}{2} \leq 2 + 2 \cdot \frac{1}{8} = \frac{9}{8}$$

$$\Rightarrow y \left( x^2 + \frac{1}{x^2} \right) \leq \frac{9}{8} \Rightarrow 0 < y \leq \left( \frac{9/8}{x^2 + \frac{1}{x^2}} \right) \leq \frac{9}{16}$$

$$\left[ \begin{array}{l} \because x^2 + \frac{1}{x^2} \geq 2 \\ \Rightarrow 0 < \frac{1}{\left( x^2 + \frac{1}{x^2} \right)} \leq \frac{1}{2} \end{array} \right]$$

$\therefore$  Assertion is incorrect, and reason is correct

5. (a)  $r = 4R \sin \frac{A}{2} \sin \frac{B}{2} \sin \frac{C}{2}$  but  $\sin \frac{A}{2} \cdot \sin \frac{B}{2} \cdot \sin \frac{C}{2} \in \left( 0, \frac{1}{8} \right]$

$$\Rightarrow r \in \left( 0, \frac{R}{2} \right) \Rightarrow R \geq 2r$$

$\Rightarrow$  Reason is correct

$$\therefore \text{ If } R = 12, r \in (0, 6] \Rightarrow r \neq 8$$

6. (d)  $\tan A \tan B \tan C = 1$  does not hold for all acute angled triangle.

e.g., If  $\angle A = 75^\circ, \angle B = 75^\circ, \angle C = 30^\circ$  then  $\tan A \tan B \tan C = (2 + \sqrt{3})^2 \left(\frac{1}{\sqrt{3}}\right) = 4 + \frac{7}{\sqrt{3}} \neq 1$

But if  $\Delta$  is obtuse angled one of  $\tan A, \tan B$  and  $\tan C$  is negative and other two positive thus  $\tan A \tan B \tan C$  is negative

$\therefore$  Assertion is incorrect but reason correct

7. (a) It is true that length of angle bisector AD is given by

$$\begin{aligned} \frac{2bc}{(b+c)} \cos(A/2) &= \frac{2bc}{(b+c)} \left[ \sqrt{\frac{1+\cos A}{2}} \right] \\ &= \frac{2bc}{(b+c)} \left[ \sqrt{\frac{1+\left(\frac{b^2+c^2-a^2}{2bc}\right)}{2}} \right] \\ &= \frac{2bc}{(b+c)} \frac{\sqrt{(b+c)^2 - a^2}}{4bc} = bc \sqrt{1 - \frac{a^2}{(b+c)^2}} \end{aligned}$$

$\Rightarrow$  Assertion and reason both are correct and reason correctly explains the assertion

8. (a) Let  $\angle A = \pi/2 \Rightarrow a^2 = b^2 + c^2$

$$\begin{aligned} \therefore \frac{a^2 + b^2 + c^2}{R^2} &= \frac{2a^2}{R^2} = 2 \left[ \frac{a}{R} \right]^2 = 2(2\sin A)^2 \\ &= 2[4\sin^2 \pi/2] = 8 \end{aligned}$$

9. (d) In a cyclic quadrilateral ABCD,  $\angle A + \angle C = \pi; \angle B + \angle D = \pi$

$$\Rightarrow \cos A = \cos(\pi - C); \cos B = \cos(\pi - D)$$

$$\Rightarrow \cos A + \cos C = \cos B + \cos D = 0$$

$$\Rightarrow \Sigma \cos A = 0$$

$\therefore$  Reason is correct, but assertion is incorrect as each of A, B, C, D lies in the interval  $(0, \pi)$  in which  $\sin A, \sin B, \sin C, \sin D$  are positive.

$$\Rightarrow \Sigma \sin A \neq 0$$

Also we have a counter example when ABCD is a rectangle, where  $\Sigma \sin A = 4$  and  $\neq 0$

**SECTION-VI (LINKED COMPREHENSION TYPE ANSWERS)**

**Passage A:**

1. (d)  $\Delta = \frac{1}{2} ap_1 \Rightarrow \frac{1}{p_1} = \frac{a}{2\Delta}$ . Similarly  $\frac{1}{p_2} = \frac{b}{2\Delta}; \frac{1}{p_3} = \frac{c}{2\Delta}$

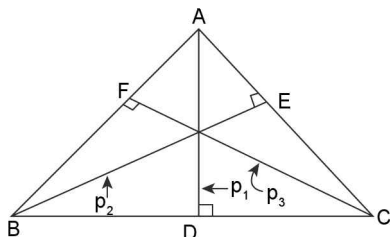

$$\therefore \frac{1}{p_1} + \frac{1}{p_2} + \frac{1}{p_3} = \frac{1}{2}$$

$$\Rightarrow \frac{1}{\Delta}(a+b+c) = 1 \Rightarrow \Delta = a+b+c \geq 3\sqrt[3]{abc}$$

$$\Rightarrow \Delta^3 \geq 27(abc) \dots\dots(i)$$

$$\text{Now, } p_1 \cdot p_2 \cdot p_3 = \frac{8\Delta^3}{abc} \geq \frac{(27abc)}{abc}$$

$$\Rightarrow p_1 \cdot p_2 \cdot p_3 \geq 216$$

2. (b)  $\frac{\cos A}{p_1} + \frac{\cos B}{p_2} + \frac{\cos C}{p_3} = \frac{a \cos A}{2\Delta} + \frac{b \cos B}{2\Delta} + \frac{c \cos C}{2\Delta}$

$$= \frac{R \sin 2A}{2\Delta} + \frac{R \sin 2B}{2\Delta} + \frac{R \sin 2C}{2\Delta}$$

$$= \frac{R}{2\Delta} (\sin 2A + \sin 2B + \sin 2C)$$

$$= \frac{R}{2\Delta} (4 \sin A \sin B \sin C) = \frac{4R}{2\Delta} \cdot \frac{a}{2R} \cdot \frac{b}{2R} \cdot \frac{c}{2R}$$

$$= \left(\frac{abc}{4\Delta}\right) \cdot \left(\frac{1}{R^2}\right) = R \cdot \frac{1}{R^2} \left(\because \frac{abc}{4\Delta} = R\right) = \frac{1}{R}$$

3. (d)  $\frac{b^2 p_1}{c} + \frac{c^2 p_2}{a} + \frac{a^2 p_3}{b} = \frac{b^2 (2\Delta)}{c} + \frac{c^2 (2\Delta)}{a} + \frac{a^2 (2\Delta)}{b}$

$$= 2\Delta \left( \frac{b^2}{ac} + \frac{c^2}{ab} + \frac{a^2}{bc} \right) \dots\dots(i)$$

By A.M.  $\geq$  G.M.,  $\frac{b^2}{ac} + \frac{c^2}{ab} + \frac{a^2}{bc} \geq 3$

$\therefore$  From (i) minimum value =  $6\Delta$

4. (c)  $p_1^{-2} + p_2^{-2} + p_3^{-2} = \frac{1}{p_1^2} + \frac{1}{p_2^2} + \frac{1}{p_3^2}$

$$= \frac{a^2}{4\Delta^2} + \frac{b^2}{4\Delta^2} + \frac{c^2}{4\Delta^2} = \frac{\Sigma a^2}{4\Delta^2}$$

5. (b)  $p_1, p_2, p_3$  are in A.P.  $\Rightarrow \frac{2\Delta}{a}, \frac{2\Delta}{b}, \frac{2\Delta}{c}$  are in A.P.

$\Rightarrow a, b, c$  are in H.P.

**Passage B:**

6. (c)  $A_1 A_2 = 2A_1 L = 2R \sin \pi/n$

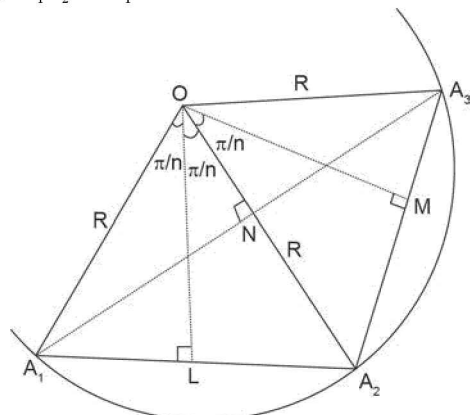



**3.120** > Trigonometry

Similarly  $A_1A_3 = 2A_1N = 2R \sin 2(\pi/n)$  and so on. Finally

$$A_1A_3 = 2R \sin \left\{ (j-1) \frac{\pi}{n} \right\}$$

7. (b)  $\tan \frac{\pi}{n} = \frac{a}{2r}$

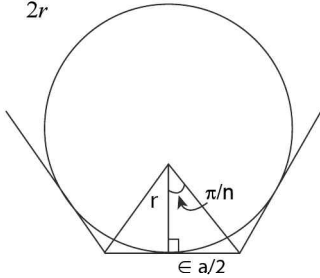

$$\Rightarrow r = \frac{a}{2} \cot \left( \frac{\pi}{n} \right)$$

8. (d) Also  $R = \frac{a}{2} \operatorname{cosec} \frac{\pi}{n}$

$$\therefore r + R = \frac{a}{2} \left[ \cot \frac{\pi}{n} + \operatorname{cosec} \frac{\pi}{n} \right] = \frac{a}{2} \left[ \frac{1 + \cos(\pi/n)}{\sin(\pi/n)} \right]$$

$$= \frac{a}{2} \left[ \frac{2 \cos^2 \left( \frac{\pi}{2n} \right)}{2 \sin \left( \frac{\pi}{2n} \right) \cos \left( \frac{\pi}{2n} \right)} \right] = \frac{a}{2} \cot \left( \frac{\pi}{2n} \right)$$

9. (a) Area of regular polygon of n-sides

$$= n \left( \frac{1}{2} R^2 \sin \left( \frac{2\pi}{n} \right) \right) = \frac{nR^2}{2} \sin \left( \frac{2\pi}{n} \right)$$

10. (d) Perimeter of regular pentagon = perimeter of regular decagon

$$\Rightarrow 5a_1 = 10a_2; a_1 = \text{side length}$$

$$\Rightarrow \frac{a_1}{a_2} = 2$$

$$\Rightarrow \frac{2R_1 \sin \left( \frac{\pi}{5} \right)}{2R_2 \sin \left( \frac{\pi}{10} \right)} = 2 \Rightarrow \frac{R_1}{R_2} = \frac{2 \sin(\pi/10)}{\sin(\pi/5)}$$

$$\Rightarrow \frac{A_1}{A_2} = \frac{\left( 5 \frac{R_1^2}{2} \sin \left( \frac{2\pi}{5} \right) \right)}{10 \frac{R_2^2}{2} \sin \left( \frac{2\pi}{10} \right)} = \frac{1}{2} \frac{R_1^2}{R_2^2} \frac{\sin \frac{2\pi}{5}}{\sin \left( \frac{2\pi}{5} \right)}$$

$$= \frac{1}{2} \left( \frac{4 \sin^2 \pi/10}{\sin^2 \pi/5} \right) \cdot \frac{2 \sin \frac{\pi}{5} \cos \frac{\pi}{5}}{\left( \sin \frac{\pi}{5} \right)} \frac{\cos \frac{\pi}{5}}{\cos^2 \pi/10} = \frac{2 \cos \pi/5}{\cos^2 \pi/10} = \frac{2 \cos \pi/5}{1 + \cos \pi/5}$$

$$\text{But } \cos \frac{\pi}{5} = \frac{\sqrt{5} + 1}{4} \Rightarrow \frac{A_1}{A_2} = \frac{2}{\sqrt{5}}$$

**Passage C**

a, b,  $\angle A$  are give,  $\cos A = \frac{b^2 + c^2 - a^2}{2bc}$

$$\Rightarrow c^2 - (2b \cos A)c + b^2 - a^2 = 0$$

$$\Rightarrow c = \frac{2b \cos A \pm \sqrt{4b^2 \cos^2 A - 4(b^2 - a^2)}}{2}$$

$$\Rightarrow c = b \cos A \pm \sqrt{a^2 - b^2 \sin^2 A}$$

$$\therefore \Delta\text{'s are possible when } a > b \sin A \quad \dots \text{(i)}$$

Also two  $\Delta\text{'s}$  are possible when two values of c are positive.

11. (b) i.e.,  $b \cos A + \sqrt{a^2 - b^2 \sin^2 A} > 0 \quad \dots \text{(ii)}$

And  $b \cos A - \sqrt{a^2 - b^2 \sin^2 A} > 0 \quad \dots \text{(iii)}$

Also  $\frac{a}{\sin A} = \frac{b}{\sin B} \Rightarrow \sin B = \frac{b \sin A}{a} \quad \dots \text{(iv)}$

Now if  $a > b$ , then  $a > b \sin A$

$$\Rightarrow a^2 - b^2 \sin^2 A > b^2 - b^2 \sin^2 A$$

$$\Rightarrow \sqrt{a^2 - b^2 \sin^2 A} > b \cos A$$

$$\Rightarrow b \cos A - \sqrt{a^2 - b^2 \sin^2 A} < 0$$

$\therefore$  If  $a < b$ , then  $a^2 - b^2 \sin^2 A < b^2 - b^2 \sin^2 A$

$$\Rightarrow \sqrt{a^2 - b^2 \sin^2 A} < b \cos A$$

$$\Rightarrow b \cos A - \sqrt{a^2 - b^2 \sin^2 A} > 0$$

Thus  $a > \sin A$  and  $a < b$

12. (c)  $|c_1 - c_2| = 2\sqrt{a^2 - b^2 \sin^2 A}$

13. (d)  $c_1^2 - 2c_1c_2 \cos 2A + c_2^2 = (c_1 + c_2)^2 - 2c_1c_2 - 2c_1c_2 \cos 2A = (c_1 + c_2)^2 - 2c_1c_2(1 + \cos 2A) = (2b \cos A)^2 - 2(b^2 - a^2)(1 + \cos 2A) = 4b^2 \cos^2 A - 2(b^2 - a^2)(2 \cos^2 A) = 4 \cos^2 A [b^2 - b^2 + a^2] = 4a^2 \cos^2 A$

14. (b) Let AD, AB be two possible positions of the side C

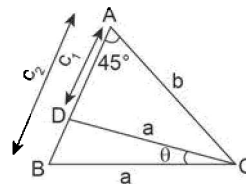

By cosine rule,  $\cos \theta = \frac{2a^2 - (c_2 - c_1)^2}{2a^2} \quad \dots \text{(i)}$

By cosine rule in  $\Delta ADC$ ,  $\frac{1}{\sqrt{2}} = \frac{b^2 - c_2^2 - a^2}{2bc_2}$

$$\Rightarrow a^2 = b^2 + c_2^2 - \sqrt{2}bc_2 \quad \dots \text{(ii)}$$

By cosine rule in  $\Delta ABC$ ,  $\frac{1}{\sqrt{2}} = \frac{b^2 + c_1^2 - a^2}{2bc_1}$

$$\Rightarrow a^2 = b^2 + c_1^2 - \sqrt{2}bc_1 \quad \dots \text{(iii)}$$

Subtracting equation (iii) - (ii), we get  $c_1^2 - c_2^2 = \sqrt{2}b(c_1 - c_2)$

$$\Rightarrow c_1 + c_2 = \sqrt{2}b \quad \dots\dots\dots (iv)$$

Putting equation (iv) in (ii), we get

$$a^2 = b^2 - c_1c_2 = \left(\frac{c_1 + c_2}{\sqrt{2}}\right)^2 - c_1c_2 \text{ from (iv)} = \frac{c_1^2 + c_2^2}{2}$$

Putting  $a^2 = \frac{c_1^2 + c_2^2}{2}$  in equation (i), we get

$$\cos\theta = \frac{2\sqrt{c_1c_2}}{c_1^2 + c_2^2}$$

**Passage D**

$$a + b = x \quad \dots\dots (i)$$

$$a \cdot b = y \quad \dots\dots (ii)$$

$$(x \geq 2\sqrt{y})$$

$$(x + z)(x - z) = y; \quad \dots\dots (iii)$$

and z is third side of  $\Delta$  opposite to vertex C.

15. (b) From (iii),  $(a + b + z)(a + b - z) = ab$

$$\Rightarrow \frac{a^2 + b^2 - z^2 + 2ab}{ab} = 1$$

$$\Rightarrow \frac{a^2 + b^2 - z^2}{2ab} = \frac{-1}{2} \Rightarrow \cos C = \frac{-1}{2}$$

$$\Rightarrow C = \frac{2\pi}{3} \text{ or } 120^\circ$$

16. (d) By sine formula  $\frac{z}{\sin C} = 2R$

$$\Rightarrow R = \frac{z}{2\sin C} = \frac{z}{2\sin \frac{2\pi}{3}} = \frac{z}{\sqrt{3}}$$

$$17. (c) r = \frac{\Delta}{s} = \frac{\frac{1}{2}ab\sin C}{\frac{1}{2}(x+z)} = \frac{ab\sin C}{(x+z)} = \frac{y\sqrt{3}}{2(x+z)}$$

$$18. (a) \Delta = \text{area of } \Delta = \frac{1}{2} ab \sin C = \frac{y}{2} \cdot \frac{\sqrt{3}}{2} = \frac{\sqrt{3}y}{4}$$

19. (a)  $a + b = x, ab = y$

$$\Rightarrow a + \frac{y}{a} = x \Rightarrow a^2 - ax + y = 0$$

$$\Rightarrow a, b = \frac{x \pm \sqrt{x^2 - 4y}}{2}$$

Thus sides are given by  $\frac{x \pm \sqrt{x^2 - 4y}}{2}, z$

**Passage E**

20. (a) LMN is a pedal  $\Delta$ , with sides  $NM = a\cos A, NL = b\cos B,$  and  $LM = c\cos C$

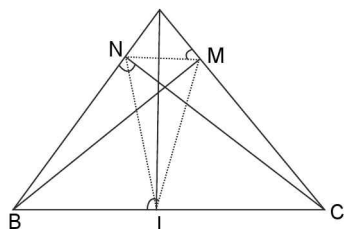

$$\begin{aligned} \Rightarrow \lambda (\text{perimeter of LMN}) &= a\cos A + b\cos B + c\cos C = \Sigma 2R\sin A\cos A = R \Sigma \sin 2A = R(4\sin A \sin B \sin C) \\ &= 4R \left(\frac{a}{2R}\right) \left(\frac{b}{2R}\right) \left(\frac{c}{2R}\right) = \frac{abc}{2R^2} = \frac{4R\Delta}{2R^2} \left(\because \Delta = \frac{abc}{4R}\right) \\ &= \frac{2\Delta}{R} = \frac{2(rs)}{R} = \frac{r}{R}(2s) \Rightarrow \lambda = \frac{r}{R}(\mu) \Rightarrow \frac{\lambda}{\mu} = \frac{r}{R} \end{aligned}$$

21. (c)  $\Delta_1 + \Delta_2 + \Delta_3 = \Delta - (\text{area of pedal } \Delta LMN)$   
 $= \Delta - \frac{1}{2}R^2 \sin 2A \sin 2B \sin 2C \quad \dots\dots (i)$

Also  $\Delta = \frac{1}{2} ab \sin C$   
 $\Rightarrow \Delta = \frac{1}{2} (2R \sin A) (2R \sin B) (\sin C)$   
 $\Rightarrow \Delta = 2R^2 \sin A \sin B \sin C \quad \dots\dots (ii)$

From (i), we get,  $\Delta_1 + \Delta_2 + \Delta_3 = \Delta - 2(2R^2 \sin A \sin B \sin C) \times \cos A \cos B \cos C = \Delta - 2\Delta \cos A \cos B \cos C$  (from (ii))  $= \Delta (1 - 2\cos A \cos B \cos C)$

22 (b) Area of pedal  $\Delta LMN$  is given by  $\Delta' = \frac{1}{2} R^2 \sin 2A \sin 2B \sin 2C = \frac{1}{2} R^2 (8 \sin A \cos A \cdot \sin B \cos B \cdot \sin C \cos C) = 2[2R^2 \sin A \sin B \sin C] \cos A \cos B \cos C = 2\Delta \cos A \cos B \cos C$   
 $\Rightarrow \frac{\Delta'}{\Delta} = 2\cos A \cos B \cos C$

23. (c) By sine formula applied to  $\Delta LMN$ , we have  $\frac{NM}{\sin \angle NLM} = 2R'$ ;  $R'$  = circum radius of  $\Delta LMN$ .  
 $\Rightarrow \frac{a \cos A}{\sin(180^\circ - 2A)} = 2R'$   
 $\Rightarrow \frac{a \cos A}{2\sin A \cos A} = 2R'$   
 $\Rightarrow R = 2R' \quad (\because a = 2R \sin A)$   
 $\Rightarrow R' = R/2$

24. (c)  $r' = \text{inradius of Pedal } \Delta LMN = \frac{\text{Area of } \Delta LMN}{\text{semi perimeter of } \Delta LMN}$   
 $= \frac{\frac{1}{2}R^2 \sin 2A \sin 2B \sin 2C}{\frac{1}{2}(R\sin 2A + R\sin 2B + R\sin 2C)}$   
 $= \frac{R^2 \sin 2A \sin 2B \sin 2C}{R(4\sin A \sin B \sin C)}$   
 $= \frac{R(8\sin A \sin B \sin C)(\cos A \cos B \cos C)}{(4\sin A \sin B \sin C)} = 2R \cos A \cos B \cos C$   
 $\Rightarrow r' \sec A \sec B \sec C = 2R$

**Passage F**

25. (c, d) Clearly orthocentre of  $\Delta ABC$  is the same as incentre of pedal triangle. So option (c) is the correct option. Further we know that the point of intersection of radical axes of three circles taken pair wise is called radical centre.

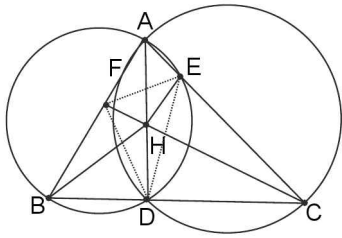

Now AD being the common chord of diameter circles on AB and AC, implies AD is the radical axis of these two circles. Similarly BE and CF will be the radical axis of circles with diameter AB, BC and that of circles with diameter AC, BC respectively. Hence they intersect at H (orthocenter of  $\Delta ABC$ ). Thus H is the radical centre of circles with their diameter on AB, BC and CA. So, (d) is also correct option.

26. (d) Clearly AFHE is cyclic quadrilateral as  $\angle AFH + \angle AEH = 180^\circ$
27. (a) AFHE, BFHD, CDHE are clearly cyclic quadrilateral as each of two opposite angles of a pair are right angles. Also in quadrilateral FECB,  $\angle BFD = C$  and  $\angle DFE = 180^\circ - 2C$   
 $\Rightarrow \angle BFE = C + 180^\circ - 2C = 180^\circ - C$   
 $\Rightarrow \angle BFE + \angle BCE = 180^\circ - C + C = 180^\circ$   
 $\Rightarrow$  FECB is a cyclic quadrilateral, similarly FDCA and DEAB are cyclic quadrilaterals.  
 Thus total 6 cyclic quadrilaterals are there.
28. (a, b, c) Angles of pedal triangle are supplement of double of opposite angle i.e.,  $180^\circ - 2A, 180^\circ - 2C, 180^\circ - 2C$ . Thus (a) is correct.  
 Also  $\angle AFE = \angle AHE = \angle C$  ( $\because$  AFHE is cyclic) and  $\angle BFD = \angle ACB = \angle C$   
 $\Rightarrow$  (b) is correct  
 Further  $\angle BAD = \pi/2 - B$  and  $\angle BED = \pi/2 - B$   
 $\Rightarrow$  (c) is also correct
29. (a, c) In  $\Delta AHE, AH = AE \sec(90^\circ - C)$   
 $\Rightarrow AH = AE \operatorname{cosec} C$  ... (i)

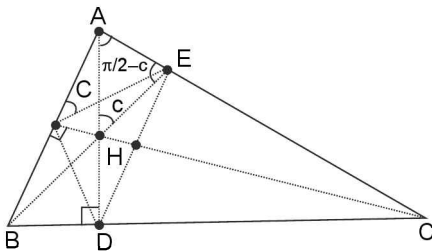

Also in  $\Delta ABE, \cos A = \frac{AE}{AB}$   
 $\Rightarrow AE = AB \cos A$  ..... (ii)  
 $\therefore$  From (i) and (ii),  $AH = AB \cos A \operatorname{cosec} C$   
 $\Rightarrow AH = \frac{c \cos A}{\sin C} = 2R \cos A = a \cot A$   
 $\Rightarrow a \cot A$

Thus distance of orthocenter from vertices A, B and C are respectively  $2R \cos A, 2R \cos B, 2R \cos C$  or a  $\cot A, b \cot B, c \cot C$  respectively.

30. (b) In  $\Delta AHF, \angle HAF = \pi/2 - B$   
 $\sin\left(\frac{\pi}{2} - B\right) = \frac{HF}{AH}$   
 $\Rightarrow HF = AH \cos B \quad \Rightarrow HF = 2R \cos A \cos B$
31. (a)  $\frac{AH}{HD} = \frac{2R \cos A}{2R \cos B \cos C} = \frac{\cos A}{\cos B \cos C}$   
 $= \frac{\left(\frac{1}{\cos B \cos C}\right)}{\left(\frac{1}{\cos A}\right)} = \frac{\left(\frac{\sin A}{\cos B \cos C}\right)}{\left(\frac{\sin A}{\cos A}\right)} = \frac{\left[\frac{\sin(B+C)}{\cos B \cos C}\right]}{\tan A}$   
 $= \frac{\tan B + \tan C}{\tan A}$   
 Thus assertion and reason both are correct and reason explains the assertions correctly.
32. (a, b, c, d) Perimeter of pedal  
 $\Delta = \Sigma R \sin 2A$  ..... (option (b))  
 $= \Sigma \frac{a}{2 \sin A} \sin 2A = \Sigma a \cos A$  ..... (option (a))  
 Also  $\Sigma R \sin 2A = 4R \sin A \sin B \sin C$  ..... (option (c))  
 Also Area of  $\Delta ABC = \Delta = \frac{1}{2} ab \sin C = \frac{1}{2} (2R \sin A)(2R \sin B) \sin C = 2R^2 \sin A \sin B \sin C$   
 $\therefore$  Perimeter =  $4R \sin A \sin B \sin C = 4R \left(\frac{\Delta}{2R^2}\right) = \frac{2\Delta}{R}$
33. (a, b) Area of pedal  $\Delta DEF = \frac{1}{2} DE \times EF \sin \angle DEF = \frac{1}{2} (R \sin 2C) \times (R \sin 2A) \times \sin(180^\circ - 2B)$   
 $= \frac{1}{2} R^2 \sin A \sin 2B \sin 2C$ . Also  $\Delta = 2R^2 \sin A \sin B \sin C$   
 $\Rightarrow$  Area of pedal  $\Delta DEF = 2\Delta \cos A \cos B \cos C$
34. (a, b, c, d) Nine point circle is the circle passing through 3 feet of altitudes, mid points of sides, and mid-points of line segments joining the orthocenter and vertices.  
 $\Rightarrow$  Circumcircle of pedal  $\Delta DEF$  is a nine point circle  
 $\Rightarrow$  Option (a) is correct  
 Also circumradius of nine point circle = Circum radius of pedal  $\Delta$   
 $= \frac{EF}{2 \sin \angle EDF} = \frac{R \sin 2A}{2 \sin(180^\circ - 2A)} = \frac{R}{2}$   
 $\Rightarrow$  Option (b) is correct  
 Now relation between inradius and circumradius is  
 $r = 4R \sin \frac{A}{2} \sin \frac{B}{2} \sin \frac{C}{2}$  for  $\Delta ABC$   
 $\therefore$  For pedal  $\Delta DEF$ ;  
 $r_p = 4R_q \sin\left(\frac{180^\circ - 2A}{2}\right) \sin\left(\frac{180^\circ - 2B}{2}\right) \sin\left(\frac{180^\circ - 2C}{2}\right)$

$$\Rightarrow r_p = 4\left(\frac{R}{2}\right)\cos A\cos B\cos C$$

$$\Rightarrow r_p = 2R \cos A \cos B \cos C$$

$\Rightarrow$  (c) is correct

For equilateral  $\Delta ABC$ ,  $r = \frac{R}{2}$  and  $r_p = 2R\left(\frac{1}{2}\right)\left(\frac{1}{2}\right)\left(\frac{1}{2}\right)$

$$\Rightarrow r = \frac{R}{2} \text{ and } r_p = \frac{R}{4} \Rightarrow 2r_p = \frac{R}{2} \text{ and circumradius of pedal}$$

$$\Delta = R_p = R/2$$

$$\therefore R_p = r = \frac{R}{2} = 2r_p \Rightarrow \text{(d) is correct}$$

**SECTION-VII (MATRIX MATCH TYPE ANSWERS)**

1. (i)  $\rightarrow$  (b, d); (ii)  $\rightarrow$  (a, e); (iii)  $\rightarrow$  (c)

(i)  $a^4 - 2(b^2 + c^2)a^2 + b^4 + b^2c^2 + c^4 = 0$ ,

$$a^2 = \frac{2(b^2 + c^2) \pm \sqrt{4(b^2 + c^2)^2 - 4(b^4 + b^2c^2 + c^4)}}{2}$$

$$\Rightarrow a^2 = (b^2 + c^2) \pm \sqrt{b^2c^2}$$

$$\Rightarrow a^2 = b^2 + c^2 \pm bc \Rightarrow b^2 + c^2 - a^2 = \pm bc$$

$$\Rightarrow \frac{b^2 + c^2 - a^2}{2bc} = \pm \frac{1}{2} \Rightarrow \cos A = \pm \frac{1}{2}$$

$$\Rightarrow A = 60^\circ \text{ or } 120^\circ$$

(ii)  $a^4 + b^4 + c^4 = a^2b^2 + 2b^2c^2 + 2c^2a^2$

$$= c^4 - (2b^2 + 2a^2)c^2 + (a^4 + b^4 - a^2b^2) = 0$$

$$\Rightarrow c^2 = \frac{2(b^2 + a^2) \pm \sqrt{4(b^2 + a^2)^2 - 4(a^4 + b^4 - a^2b^2)}}{2}$$

$$\Rightarrow \angle C = (b^2 + a^2) \pm \sqrt{3a^2b^2}$$

$$\Rightarrow c^2 = b^2 + a^2 \pm \sqrt{3ab} \Rightarrow a^2 + b^2 - c^2 = \pm \sqrt{3ab}$$

$$\Rightarrow \frac{a^2 + b^2 - c^2}{2ab} = \pm \frac{\sqrt{3}}{2} \Rightarrow \cos C = \pm \frac{\sqrt{3}}{2}$$

$$\Rightarrow C = \frac{\pi}{6} \text{ or } \frac{5\pi}{6}$$

(iii)  $a^4 + b^4 + c^4 + 2a^2c^2 = 2a^2b^2 + 2b^2c^2$

$$\Rightarrow b^4 - 2(a^2 + c^2)b^2 + a^4 + c^4 + 2a^2c^2 = 0$$

$$\Rightarrow b^2 = \frac{2(a^2 + c^2) \pm \sqrt{4(a^2 + c^2)^2 - 4(a^4 + c^4 + 2a^2c^2)}}{2}$$

$$\Rightarrow b^2 = a^2 + c^2 \pm \sqrt{0} \Rightarrow a^2 + c^2 - b^2 = 0$$

$$\Rightarrow \cos B = 0 \Rightarrow \angle B = \pi/2$$

2. (i)  $\rightarrow$  (a, e); (ii)  $\rightarrow$  (b, d); (iii)  $\rightarrow$  (b, c, e)

(i)  $2a^2 + b^2 + c^2 = 2ac + 2ab$

$$\Rightarrow a^2 + b^2 - 2ab + a^2 + c^2 - 2ac = 0$$

$$\Rightarrow (a - b)^2 + (a - c)^2 = 0$$

$$\Rightarrow a = b = c$$

$\Rightarrow \Delta ABC$  is equilateral  $\Delta$ . Also B, C, A are in A.P. with common difference 0.

$\Rightarrow$  (e) is also correct

(ii)  $a^2 + b^2 + c^2 = \sqrt{2}b(c + a)$ ,  $a^2 + b^2 + c^2 = \sqrt{2}bc + \sqrt{2}ab$

$$\Rightarrow a^2 + b^2 - \sqrt{2}ab + c^2 - \sqrt{2}bc = 0$$

$$\Rightarrow a^2 + \frac{b^2}{2}\sqrt{2ab} + \frac{b^2}{2} + c^2 - \sqrt{2}bc = 0$$

$$\Rightarrow a^2\left(\frac{b}{\sqrt{2}}\right)^2 - 2(a)\left(\frac{b}{\sqrt{2}}\right) + c^2 + \left(\frac{b}{\sqrt{2}}\right)^2 - 2(c)\left(\frac{b}{\sqrt{2}}\right) = 0$$

$$\Rightarrow \left(a - \frac{b}{\sqrt{2}}\right)^2 + \left(c - \frac{b}{\sqrt{2}}\right)^2 = 0$$

$$\Rightarrow a = c = \frac{b}{\sqrt{2}} \Rightarrow a^2 + c^2 = \frac{b^2}{2} + \frac{b^2}{2} = b^2$$

$\Rightarrow \Delta$  is right angled and isosceles

(iii)  $a^2 + b^2 + c^2 = bc + ca \sqrt{3}a$

$$\Rightarrow a^2 + b^2 - bc + c^2 - \sqrt{3}ca = 0$$

$$\Rightarrow a^2 + b^2 - 2\left(\frac{bc}{2}\right) + c^2 - 2\left(\frac{\sqrt{3}ca}{2}\right) = 0$$

$$\Rightarrow b^2 - 2\left(b \cdot \frac{c}{2}\right) + c^2 + a^2 - 2\left(a \cdot \frac{\sqrt{3}c}{2}\right) = 0$$

$$\Rightarrow b^2 - 2\left(b \cdot \frac{c}{2}\right) + \frac{c^2}{4} + \frac{3c^2}{4} + a^2 - 2\left(a \cdot \frac{\sqrt{3}c}{2}\right) = 0$$

$$\Rightarrow \left(b - \frac{c}{2}\right)^2 + \left(\frac{\sqrt{3}c}{2} - a\right)^2 = 0$$

$$\Rightarrow b = \frac{c}{2} \text{ and } a = \frac{\sqrt{3}c}{2} \Rightarrow a = \frac{\sqrt{3}c}{2}, b = \frac{c}{2}, c = c$$

$\Rightarrow \Delta$  is scalene. Also  $a^2 + b^2 = c^2$

$\Rightarrow \Delta$  is right angled with  $\angle C = \pi/2$

$\therefore$  By sine formula  $\frac{a}{\sin A} = \frac{b}{\sin B} = \frac{c}{1}$

$$\Rightarrow \frac{\frac{\sqrt{3}c}{2}}{\sin A} = \frac{\frac{c}{2}}{\sin B} = \frac{c}{1} \Rightarrow \sin A = \sqrt{3}/2; \sin B = 1/2$$

$$\Rightarrow A = \frac{\pi}{3}; B = \frac{\pi}{3}$$

$\Rightarrow B, C, A$  are in A.P.

3. (i)  $\rightarrow$  (c); (ii)  $\rightarrow$  (a); (iii)  $\rightarrow$  (d, e); (iv)  $\rightarrow$  (b)

(i) Area of  $\Delta ADB = -BD \times AD = \frac{1}{2}(AB) \cos B \times (AB)$

$$\sin B = \frac{1}{2}c^2 \left(\frac{1}{2}\sin 2B\right) = \frac{1}{4}c^2 \sin 2B$$

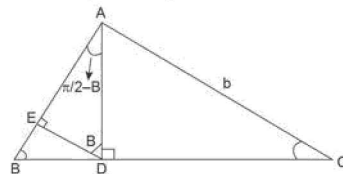

(ii) Area of  $\Delta ADC = \frac{1}{2}(DC) \times (AD)$

$$= \frac{1}{2}(AC \cos C) \times (AC \sin C) = \frac{1}{4}b^2 \sin 2C$$

(iii) Area of  $\Delta ADE = \frac{1}{2}(DE) \times (AE)$

$$= \frac{1}{2}(AD \cos B)(AD \sin B) = \frac{1}{2}AD^2 \sin B \cos B$$

$$= \frac{1}{2}(b \sin C)^2 \sin B \cos B = \frac{1}{4}b^2 \sin^2 C \sin 2B$$

3.124 > Trigonometry

Also area of  $\triangle ADE = \frac{1}{2} AD^2 \sin B \cos B$  and  $AD = c \sin B$

$$\therefore \text{Area of } \triangle ADE = \frac{1}{2} (c \sin B)^2 \sin B \cos B$$

$$= \frac{1}{4} c^2 \sin^2 B \sin 2B$$

(iv) Area of  $\triangle BDE = \frac{1}{2} (DE) \times (BE)$

$$= \frac{1}{2} (BD \sin B) \times (BD \cos B)$$

$$= \frac{1}{4} (BD)^2 \sin 2B = \frac{1}{4} (AB \cos B)^2 \sin 2B$$

$$= \frac{1}{4} c^2 \cos^2 B \sin 2B$$

SECTION-VIII (INTEGER TYPE ANSWERS)

1.  $3 + \sqrt{3} > 2\sqrt{3} > \sqrt{6}$ . Let  $a = 3 + \sqrt{3}$ ,  $b = 2\sqrt{3}$ ,  $c = \sqrt{6}$

$\therefore$  A is the greatest angle and C is least.

$$\text{Now } \cos A = \frac{b^2 + c^2 - a^2}{2bc}$$

$$= \frac{2(\sqrt{3})^2 + (\sqrt{6})^2 - (3 + \sqrt{3})^2}{2(2\sqrt{3})(\sqrt{6})} = \frac{1 - \sqrt{3}}{2\sqrt{2}} = \frac{1}{2} \cdot \frac{1}{\sqrt{2}} - \frac{\sqrt{3}}{2} \cdot \frac{1}{\sqrt{2}}$$

$$= \cos 60^\circ \cos 45^\circ - \sin 60^\circ \sin 45^\circ = \cos(60^\circ + 45^\circ) = \cos 105^\circ$$

$$\Rightarrow \angle A = 105^\circ \text{ and}$$

$$\cos C = \frac{a^2 + b^2 - c^2}{2ab} = \frac{(3 + \sqrt{3})^2 + (2\sqrt{3})^2 - (\sqrt{6})^2}{2(3 + \sqrt{3})(2\sqrt{3})} = \frac{\sqrt{3}}{2}$$

$$\Rightarrow C = 30^\circ \quad \therefore A - C = 150^\circ - 30^\circ = 75^\circ$$

2. Clearly  $\angle AMB = \theta$  and  $\angle BMC = \theta$

( $\therefore$  Exterior angle equals sum of interior opposite angles of  $\triangle$ )

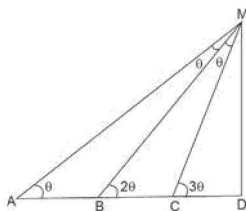

$\Rightarrow$  MB is angle bisector of  $\angle AMC$

$\therefore$  By angle bisector theorem

$$AB : BC = AM : MC \quad \dots (i)$$

In right  $\angle d \triangle AMD$ ,  $\sin \theta = \frac{MD}{AM}$

$$\Rightarrow AM = \frac{MD}{\sin \theta} \quad \dots (ii)$$

Similarly in right  $\angle d \triangle MCD$ ,  $CM = \frac{MD}{\sin 3\theta} \quad \dots (iii)$

Using (ii) and (iii) in (i) we get,  $AB : BC = \frac{\sin 3\theta}{\sin \theta} = \frac{\sin \lambda \theta}{\sin \mu \theta}$

(given)

$$\Rightarrow \lambda = 3, \mu = 1$$

$$\Rightarrow (\lambda + \mu) = 4$$

3. In right  $\angle d \triangle ABG$ ,  $AG^2 + BG^2 = AB^2 = C^2$

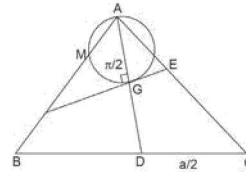

$$\Rightarrow \left(\frac{2}{3}AD\right)^2 + \left(\frac{2}{3}BE\right)^2 = c^2$$

$$\Rightarrow \frac{4}{9} \left[ \frac{1}{4}(2c^2 + 2b^2 - a^2) \right] + \frac{4}{9} \left[ \frac{1}{4}(2a^2 + 2c^2 - b^2) \right] = c^2$$

$$\Rightarrow \frac{1}{9} [4c^2 + b^2 + a^2] = c^2$$

$$\Rightarrow a^2 + b^2 = 5c^2 \quad \Rightarrow c^2 = 5$$

$$\Rightarrow c = \sqrt{5}$$

Also, BGE is tangent to circle

$$\therefore BG^2 = BA \cdot BM$$

$$\Rightarrow \left[ \frac{2}{3}(BE) \right]^2 = BA \cdot BM$$

$$\Rightarrow \frac{4}{9} \left[ \frac{1}{4}(2a^2 + 2c^2 - b^2) \right] = c \cdot BM$$

$$\Rightarrow \frac{1}{9} (18 + 10 - 16) = \sqrt{5} BM \quad \Rightarrow BM = \frac{4}{3\sqrt{5}}$$

$$\therefore BC \cdot AB \cdot BM = (a)(c) \cdot BM = (3)\sqrt{5} \left( \frac{4}{3\sqrt{5}} \right) = 4$$

4. Given  $B > A$ . A and B satisfy the equation  $3\sin x - 4\sin^3 x - k = 0$

$$\Rightarrow \sin 3x = k$$

$$\Rightarrow \sin 3A = k \text{ and } \sin 3B = k$$

$$\Rightarrow \sin 3A = \sin 3B$$

$$\Rightarrow 3A = n\pi + (-1)^n (3B); n \in \mathbb{Z}$$

$$\Rightarrow A = \frac{n\pi}{3} + (-1)^n B; n \in \mathbb{Z}$$

$$n = 0 \quad \Rightarrow A = B, \text{ but } A < B \text{ (given)}$$

$$n = -\text{ve odd integer provides -ve values of } A$$

$$n = 1 \quad \Rightarrow A + B = \pi/3$$

$$n = 2 \quad \Rightarrow A = 2\pi/3 + B$$

$$\Rightarrow A > B$$

$$n = -2 \quad \Rightarrow A + B = -2\pi/3 \text{ (impossible)}$$

$$n = 4 \quad \Rightarrow A = 4\pi/3 + B > \pi$$

(impossible)

$$n = -4 \quad \Rightarrow A = -4\pi/3 + B$$

$$\Rightarrow B - A = 4\pi/3 \text{ (impossible) as in a } \triangle, \text{ difference of two angles can't exceed } \pi.$$

$|n| \geq 4$  are impossible as they provide difference of angles of triangle or sum of angles exceeding  $\pi$ .

Thus only possibility is  $A + B = \pi/3$ , for  $n = 1$

$$c = 2\pi/3 \quad \Rightarrow c = 120^\circ$$

5. Given

$$\frac{(a+b+c)(b+c-a)(c+a-b)(a+b-c)}{4b^2c^2} = (\sin \lambda A)^n$$

$$\begin{aligned} \text{Now L.H.S.} &= \frac{2s(2s-2a)(2s-2b)(2s-2c)}{4b^2c^2} \\ &= \frac{4s(s-a)(s-b)(s-c)}{b^2c^2} = \frac{4\Delta^2}{b^2c^2} = \frac{4}{b^2c^2} \left( \frac{a^2b^2c^2}{16R^2} \right) = \frac{a^2}{4R^2} \\ &\quad \left( \because \Delta = \frac{abc}{4R} \right) \end{aligned}$$

$$= \left( \frac{a}{2R} \right)^2 = \sin^2 A = (\sin \lambda A)^\mu \quad (\text{given})$$

$$\Rightarrow \lambda = 1; \mu = 2 \quad \Rightarrow \lambda + \mu = 3$$

$$6. \cos A + \cos B + \cos C = k + \frac{r}{R} \quad \dots (i)$$

$$\text{Now, } \cos A + \cos B + \cos C = 2 \cos \left( \frac{A+B}{2} \right) \cos \left( \frac{A-B}{2} \right) + \cos C$$

$$= 2 \sin \frac{C}{2} \cos \left( \frac{A-B}{2} \right) + 1 - 2 \sin^2 \frac{C}{2}$$

$$= 1 + 2 \sin \frac{C}{2} \left[ \cos \left( \frac{A-B}{2} \right) - \cos \left( \frac{A+B}{2} \right) \right] = 1 + 4$$

$$\sin \frac{A}{2} \sin \frac{B}{2} \sin \frac{C}{2} = 1 + \frac{r}{R}; \left( \because r = 4R \sin \frac{A}{2} \sin \frac{B}{2} \sin \frac{C}{2} \right)$$

$$\therefore \text{ From (i), we have } k = 1$$

$$\therefore \sqrt[4]{196} = \sqrt[2]{196} = 14$$

$$7. a = 2x + 3, b = x^2 + 3x + 3; c = x^2 + 2x,$$

$$\therefore \cos B = \frac{a^2 + c^2 - b^2}{2ac}$$

$$\Rightarrow \cos B = \frac{(2x+3)^2 + (x^2+2x)^2 - (x^2+3x+3)^2}{2(2x+3)(x^2+2x)}$$

$$= \frac{-(2x^3 + 7x^2 + 6x)}{2(2x^3 + 7x^2 + 6x)} = \frac{-1}{2} \Rightarrow B = 120$$

$$8. \frac{8 \cot A}{\cot B + \cot C} = \frac{8 \frac{\cos A}{\sin A}}{\frac{\cos B}{\sin B} + \frac{\cos C}{\sin C}}$$

$$= \frac{8 \left( \frac{b^2 + c^2 - a^2}{2bca} \right) \cdot 2R}{\frac{a^2 + c^2 - b^2}{2ac \cdot b} \cdot 2R + \frac{a^2 + b^2 - c^2}{2ab \cdot c} \cdot 2R} = \frac{8[b^2 + c^2 - a^2]}{2a^2}$$

$$= \frac{8(a^2)}{2a^2} = 4$$

$$9. \therefore \frac{A}{2} + \frac{B}{2} = \frac{\pi}{2} - \frac{C}{2}$$

$$\Rightarrow \tan \left( \frac{A}{2} + \frac{B}{2} \right) = \cot \frac{C}{2}$$

$$\Rightarrow \frac{\tan \frac{A}{2} + \tan \frac{B}{2}}{1 - \tan \frac{A}{2} \tan \frac{B}{2}} = \frac{1}{\tan \frac{C}{2}}$$

$$\Rightarrow \sum \tan \frac{A}{2} \tan \frac{B}{2} = 1 \quad \dots (i)$$

$$\text{Now } \sum \tan^2 \frac{A}{2} = \left( \sum \tan \frac{A}{2} \right)^2 - 2 \sum \tan \frac{A}{2} \tan \frac{B}{2}$$

$$\Rightarrow \sum \tan^2 \frac{A}{2} = \left( \sum \tan \frac{A}{2} \right)^2 - 2 \quad (\text{from (i)}) \quad \dots (ii)$$

$$\therefore \tan \frac{A}{2} \text{ etc. are positive by A.M} \geq \text{G.M.}$$

$$\sum \tan \frac{A}{2} \geq 3 \sqrt[3]{\pi \tan \frac{A}{2}}$$

$$\Rightarrow \sum \tan \frac{A}{2} \geq 3 \sqrt[3]{\left( \frac{1}{\sqrt{3}} \right)^3} = \sqrt{3}$$

( $\because$  Equality holds for equal terms)

$$\Rightarrow \left( \sum \tan \frac{A}{2} \right)^2 \geq 3$$

$$\therefore \text{ From (ii) } \sum \tan^2 \frac{A}{2} \geq 3 - 2 = 1$$

$$\begin{aligned} 10. \left( 1 + \frac{a}{c} + \frac{b}{c} \right) \left( 1 + \frac{c}{b} - \frac{a}{b} \right) &= \left( \frac{c+a+b}{c} \right) \left( \frac{b+c-a}{b} \right) \\ &= \frac{(b+c)^2 - a^2}{bc} = \frac{b^2 + c^2 + 2bc - a^2}{bc} = \frac{b^2 + c^2 - a^2}{bc} + 2 \\ &= 2 \left( \frac{b^2 + c^2 - a^2}{2bc} \right) + 2 = 2 \cos A + 2 = 2 \cos 60^\circ + 2 = 3 \end{aligned}$$

$$11. \text{ In } \triangle OBL, \cos A = \frac{OL}{OB} = \frac{r}{R}$$

$$\Rightarrow R \cos A = r$$

$$\Rightarrow R \cos A = 4R \sin \frac{A}{2} \sin \frac{B}{2} \sin \frac{C}{2}$$

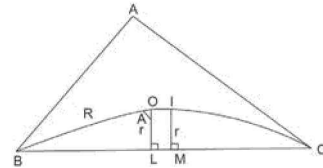

$$\Rightarrow \cos A = 4 \sin \frac{A}{2} \sin \frac{B}{2} \sin \frac{C}{2}$$

$$\Rightarrow \cos A = \cos A + \cos B + \cos C - 1$$

$$\Rightarrow 0 = \cos B + \cos C - 1$$

$$\Rightarrow \cos B + \cos C = 1$$

$$12. \frac{a \cos^2 \frac{A}{2} + b \cos^2 \frac{B}{2} + c \cos^2 \frac{C}{2}}{a + b + c}$$

$$= \frac{a \left( \frac{1 + \cos A}{2} \right) + b \left( \frac{1 + \cos B}{2} \right) + c \left( \frac{1 + \cos C}{2} \right)}{(a + b + c)}$$

$$= \frac{1}{2} + \frac{1}{2} \frac{(a \cos A + b \cos B + c \cos C)}{(a + b + c)}$$

$$= \frac{1}{2} + \frac{1}{4s} R (\sin 2A + \sin 2B + \sin 2C)$$

$$= \frac{1}{2} + \frac{1}{4s} R (4 \sin A \sin B \sin C) = \frac{1}{2} + \frac{R}{s} \left( \frac{a}{2R} \times \frac{b}{2R} \times \frac{c}{2R} \right)$$

3.126 > Trigonometry

$$\begin{aligned}
 &= \frac{1}{2} + \frac{abc}{8sR^2} = \frac{1}{2} + \frac{4R\Delta}{8sR^2} = \frac{1}{2} + \frac{\Delta}{2sR} = \frac{1}{2} + (r) \frac{1}{2R} \quad \left( \because r = \frac{\Delta}{s} \right) \\
 &= \frac{1}{2} + \frac{r}{2R} = \frac{1}{2} \left( 1 + \frac{r}{R} \right) \leq \frac{1}{2} \left( 1 + \frac{1}{2} \right) = \frac{3}{4} \\
 &\left[ \because r = 4R \sin \frac{A}{2} \sin \frac{B}{2} \sin \frac{C}{2} \leq 4R \cdot \frac{1}{8} \right] \\
 &\Rightarrow r \leq \frac{R}{2} \Rightarrow \frac{r}{R} \leq \frac{1}{2} \\
 \therefore \text{Expression} &\leq \frac{3}{4} \Rightarrow \lambda = \frac{3}{4} \Rightarrow 4\lambda = 3
 \end{aligned}$$

13. Applying sine rule to  $\triangle ADE$ , we have  $\frac{x}{\sin A} = \frac{AE}{\sin B} = \frac{AD}{\sin C}$

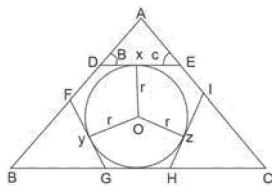

$$\begin{aligned}
 \Rightarrow AE &= \frac{x \sin B}{\sin A} \text{ and } AD = \frac{x \sin C}{\sin A} \\
 \Rightarrow \text{Perimeter of } \triangle ADE &= AD + AE + DE = \frac{x \sin C}{\sin A} + \frac{x \sin B}{\sin A} + x = x \cdot \frac{c}{a} + x \cdot \frac{b}{a} + x \\
 &= \frac{x}{a}(a+b+c) \\
 \therefore \text{Semi perimeter of } \triangle ADE &= \frac{x(a+b+c)}{2a} \\
 \Rightarrow s' &= \frac{sx}{a}; \quad s = \text{semi perimeter of } \triangle ABC \\
 \text{Clearly incircle of } \triangle ABC, &\text{ is the escribed circle of } \triangle ADE \\
 \Rightarrow r &= s' \tan \frac{A}{2} \Rightarrow r = \frac{sx}{a} \tan \frac{A}{2} \\
 \Rightarrow (s-a) \tan \frac{A}{2} &= \frac{sx}{a} \tan \frac{A}{2} \\
 \Rightarrow (s-a) &= \frac{sx}{a} \\
 \Rightarrow \frac{x}{a} &= \frac{s-a}{a}; \text{ Similarly } \frac{y}{b} = \frac{s-b}{b} \text{ and } \\
 \frac{z}{c} &= \frac{s-c}{c} \therefore \frac{2x}{a} + \frac{2y}{b} + \frac{2z}{c} = 2 \\
 \left[ \frac{s-a}{s} + \frac{s-b}{s} + \frac{s-c}{s} \right] &= \frac{2}{s}(3s-2s) = 2
 \end{aligned}$$

14. By m-n theorem,  $2 \cot \theta = \cot \frac{\pi}{6} - \cot \frac{\pi}{4}$

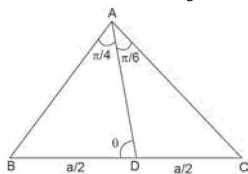

$$\begin{aligned}
 \Rightarrow 2 \cot \theta &= \sqrt{3} - 1 \\
 \Rightarrow \cot \theta &= \frac{\sqrt{3}-1}{2} \Rightarrow \theta \text{ is acute}
 \end{aligned}$$

Again applying sine rule to  $\triangle ABD$ , we have

$$\begin{aligned}
 \frac{AD}{\sin B} &= \frac{AB}{\sin \theta} = \frac{BD}{\sin \pi/4} \\
 \Rightarrow \frac{AD}{\sin \left( \pi - \frac{\pi}{4} - \theta \right)} &= \frac{c}{\sin \theta} = \frac{a/\sqrt{2}}{1/\sqrt{2}} \\
 \Rightarrow \frac{AD}{\sin \left( \frac{\pi}{4} + \theta \right)} &= \frac{c}{\sin \theta} = \frac{a}{\sqrt{2}} \\
 \Rightarrow AD &= \frac{a}{\sqrt{2}} \sin \left( \frac{\pi}{4} + \theta \right) \\
 \Rightarrow AD &= \frac{a}{\sqrt{2}} \left[ \frac{1}{\sqrt{2}} \cos \theta + \frac{1}{\sqrt{2}} \sin \theta \right] \\
 \Rightarrow AD &= \frac{a}{2} (\sin \theta + \cos \theta) \\
 \Rightarrow AD &= \frac{a}{2} \left[ \frac{2}{4-\sqrt{3}} + \sqrt{\frac{4-2\sqrt{3}}{8-2\sqrt{3}}} \right] \\
 \Rightarrow AD &= \frac{a}{2} \left[ \frac{2}{\sqrt{8-\sqrt{3}}} + \sqrt{\frac{4-2\sqrt{3}}{8-2\sqrt{3}}} \right] \\
 \Rightarrow AD &= \frac{a}{2} \left[ \frac{2+\sqrt{4-2\sqrt{3}}}{\sqrt{8-2\sqrt{3}}} \right] \\
 \Rightarrow AD &= \frac{a}{2} \left[ \frac{\sqrt{3}+1}{\sqrt{8-2\sqrt{3}}} \right] \\
 \Rightarrow BC = a &= \frac{2AD(\sqrt{8-2\sqrt{3}})}{(\sqrt{3}+1)} \\
 &= 2 \times \frac{1}{\sqrt{11-6\sqrt{3}}} \times \frac{\sqrt{8-2\sqrt{3}}}{(\sqrt{3}+1)} = \frac{2\sqrt{8-2\sqrt{3}}}{\sqrt{(11-6\sqrt{3})(4+2\sqrt{3})}} \\
 &= 2 \sqrt{\frac{8-2\sqrt{3}}{8-2\sqrt{3}}} = 2. \text{ Thus } BC = 2
 \end{aligned}$$

15.  $\because r_1 + r_2 + r_3 = r + 4R$   
 $\Rightarrow \frac{r_1 + r_2 + r_3}{r} = 1 + \frac{4R}{r}$  ... (i)

Now,  $r = 4R \sin A/2 \sin B/2 \sin C/2$

$$\Rightarrow \frac{4R}{r} = \frac{1}{\sin \frac{A}{2} \sin \frac{B}{2} \sin \frac{C}{2}} \geq \left[ \frac{3}{\sin \frac{A}{2} + \sin \frac{B}{2} + \sin \frac{C}{2}} \right]^3$$

(By A.M.  $\geq$  G.M.)  $\geq \left[ 3 \left( \frac{2}{3} \right) \right]^3 = 8$

$\therefore \frac{4R}{r} \geq 8$  ... (ii)

$\therefore$  From (i) and (ii),  $\frac{r_1 + r_2 + r_3}{r} \geq 1 + 8 = 9$

# Inverse Trigonometric Functions

# 4 CHAPTER

## INTRODUCTION

The study of trigonometry began on Indian soil, long back in 5th century A.D. The ancient Indian mathematician, Aryabhata (476 A.D.), Brahmagupta (598 A.D.), Bhaskara I (600 A.D.) and Bhaskara II (1114 A.D.) derived important results on trigonometry. All this knowledge went from India to Arabia and then from there to Europe. The Greeks had also started the study of trigonometry but their approach was so clumsy that when the Indian approach became known, it was immediately adopted throughout the world.

In India, the predecessor of the modern trigonometric functions, known as the sine of an angle, and the introduction of the sine function represents one of the main contributions of the Siddhantas (Sanskrit astronomical works) to mathematics.

Bhaskara I (about 600 A.D.) gave formulae to find the values of sine functions for angles more than  $90^\circ$ . A sixteenth century Malayalam work Yuktibhasa contains a proof for the expansion of  $\sin(A + B)$ . Exact expressions for sines or cosines of  $18^\circ$ ,  $36^\circ$ ,  $54^\circ$ ,  $72^\circ$ , etc., were given by Bhaskara II.

The symbols  $\sin^{-1}x$ ,  $\cos^{-1}x$ , etc., for arc  $\sin x$ , arc  $\cos x$ , etc., were suggested by the astronomer Sir John F.W. Herschel (1813).

In the Chapter functions (refer to our book Functions and Graphs), we have studied that the inverse of a function  $f$ , denoted by  $f^{-1}$ , exist if  $f$  is one-one and onto (bijection). There are many functions which are not bijection and hence we can not talk of their inverse. In class XI, we studied that trigonometric functions are not one-one and onto over their natural domains and ranges and hence their inverse do not exist. In present chapter, we shall learn about the restrictions on domains and ranges of trigonometric functions which ensure the existence of their inverse and observe their behaviour through graphical representation. Besides, some elementary properties will also be discussed.

The inverse trigonometric function plays an important role in calculus for they serve to define many integrals. The concepts of inverse trigonometric functions is also used in science and engineering.

## INVERSE FUNCTION

If a function is one to one and onto from  $A$  to  $B$ , then function  $g$  which associates each element  $y \in B$  to one and only one element  $x \in A$ , such that  $y = f(x)$  is called the inverse function of  $f$ , denoted by  $x = g(y)$ . Usually, we denote  $g = f^{-1}$  [Read as  $f$  inverse]

$$\therefore x = f^{-1}(y)$$

### REMARK

If  $y = f(x)$  and  $x = g(y)$  are two functions such that  $f(g(y)) = y$  and  $g(f(x)) = x$ , then  $f$  and  $g$  are said to be inverse functions of each other.  $f^{-1}(x)$  is not reciprocal of  $f(x)$  i.e.,  $1/f(x)$



### INVERSE TRIGONOMETRIC FUNCTION

Consider,  $\sin \frac{\pi}{6} = \frac{1}{2}$ ,  $\sin \frac{5\pi}{6} = \frac{1}{2}$ ,  $\sin \frac{13\pi}{6} = \frac{1}{2}$ ,  $\sin \frac{17\pi}{6} = \frac{1}{2}$ ,

$\sin\left(-\frac{11\pi}{6}\right) = \frac{1}{2}$ ,  $\sin\left(-\frac{7\pi}{6}\right) = -\frac{1}{2}$ , ..... etc. Therefore for the

question ‘which is that real angle whose sine is  $\frac{1}{2}$ ’, there are infinite answers. The problem is, if the trigonometrical equation is  $\sin y = x$ , then for the given value  $x = \frac{1}{2}$ , we have

$y = \dots, -\frac{7\pi}{6}, -\frac{11\pi}{6}, \frac{\pi}{6}, \frac{5\pi}{6}, \frac{13\pi}{6}, \dots$  i.e., for given value of  $x$ , we get infinite value of  $y$ .

∴ Correspondence from set =  $\{x : x \in \mathbb{R}; -1 \leq x \leq 1\}$  to the set =  $\{y : y \in \mathbb{R}; \sin y = x\}$  is one to many correspondence and so it cannot be a function. {∴ one-many and many-many relations are not functions}. However, if

the question is ‘which is the numerically smallest angle or real number whose sine is  $1/2$ ?’

Then the answer is  $\pi/6$ . This is one and only one answer i.e.,  $\pi/6$  is the unique answer. In this case, the relation  $\sin \pi/6 = 1/2$  is also written as:  $\pi/6 = \sin^{-1}(1/2)$  { Read as sine inverse  $1/2$ } or  $\text{arc sin}(1/2)$ . It must therefore, be noted that  $\sin^{-1}x$  is an angle and denotes the smallest numerical angle, whose sine is  $x$ .

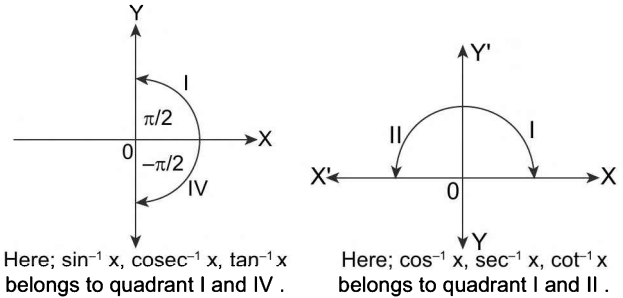

FIGURE 4.1

#### REMARKS

1.  $\sin 5\pi/6 = 1/2$  But  $5\pi/6 \neq \sin^{-1}(1/2)$  ∴  $\sin^{-1}x, \cos^{-1}x, \tan^{-1}x$ , denotes angles or real number; ‘whose sine is  $x$ ’, ‘whose cosine is  $x$ ’ and ‘whose tangent is  $x$ ’, provided that the answers given are numerically smallest available.
2. If there are two angles one positive and the other negative having same numerical value. Then we shall take the positive value. e.g.,  $\cos \frac{\pi}{4} = \frac{1}{\sqrt{2}}$  and  $\cos\left(-\frac{\pi}{4}\right) = \frac{1}{\sqrt{2}}$  But we write  $\cos^{-1}\left(\frac{1}{\sqrt{2}}\right) = \frac{\pi}{4}$  and  $\cos^{-1}\left(\frac{1}{\sqrt{2}}\right) \neq -\frac{\pi}{4}$ .
3. Quadrant I is common to all the inverse functions.
4. Quadrant III is not used in inverse function.
5. Quadrant IV is used in the clockwise direction i.e.,  $-\pi/2 \leq y \leq 0$ .

### GRAPHS OF INVERSE CIRCULAR FUNCTIONS AND THEIR DOMAIN AND RANGE

As of now we know that for a function  $f(x) = \{(x_1, y_1), (x_2, y_2), (x_3, y_3)\}$

$f^{-1}(x) = \{(y_1, x_1), (y_2, x_2), (y_3, x_3)\}$ , therefore graph of  $f^{-1}(x)$  is mirror image of graph of  $f(x)$  (corresponding to principal domain) in the line mirror  $y = x$ .

1.  $y = \sin^{-1}x$ : If  $\sin y = x$ , then  $y = \sin^{-1}x$ , under certain condition.

$$-1 \leq \sin y \leq 1; \text{ but } \sin y = x.$$

$$\therefore -1 \leq x \leq 1$$

Again,  $\sin y = -1 \Rightarrow y = -\pi/2$  and

$$\sin y = 1$$

$$\Rightarrow y = \pi/2$$

Keeping in mind numerically smallest angles or real numbers.

$$\therefore -\pi/2 \leq y \leq \pi/2$$

These restrictions on the values of  $x$  and  $y$  provide us with the domain and range for the function  $y = \sin^{-1}x$ . i.e., Domain:  $x \in [-1, 1]$ ; Range:  $y \in [-\pi/2, \pi/2]$ . To draw graph of  $y = \sin^{-1}x$ , sketch  $x = \sin y \forall y \in \left[-\frac{\pi}{2}, \frac{\pi}{2}\right]$  or reflect  $y = \sin x \forall x \in \left[-\frac{\pi}{2}, \frac{\pi}{2}\right]$  in the line  $y = x$ .

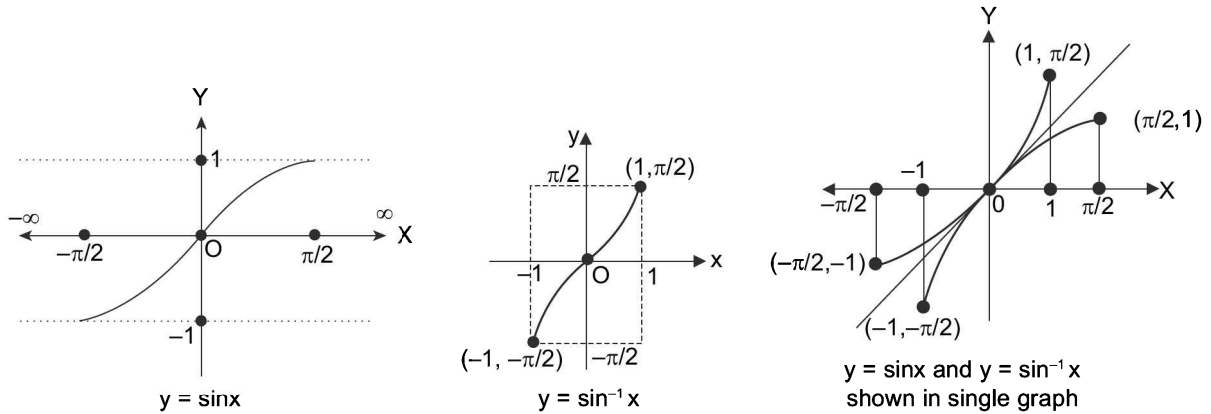

FIGURE 4.2

2.  $y = \cos^{-1}x$ : Let  $\cos y = x$  then  $y = \cos^{-1}x$ , under certain conditions  $-1 \leq \cos y \leq 1$ .  
 $\Rightarrow -1 \leq x \leq 1$ ;  $\cos y = -1 \Rightarrow y = \pi$ ,  $\cos y = 1 \Rightarrow y = 0$   
 $\therefore 0 \leq y \leq \pi$  {as  $\cos x$  is a decreasing function in  $[0, \pi]$ ; hence  $\cos \pi \leq \cos y \leq \cos 0$ }

These restrictions on the values of  $x$  and  $y$  provide us the domain and range for the function  $y = \cos^{-1}x$ .  
 i.e., Domain:  $x \in [-1, 1]$ ; Range:  $y \in [0, \pi]$ . To draw the graph of  $y = \cos^{-1}x$ . Draw  $x = \cos y$  for  $y \in [0, \pi]$  or reflect the graph of  $y = \cos x \forall x [0, \pi]$  in  $y = x$ .

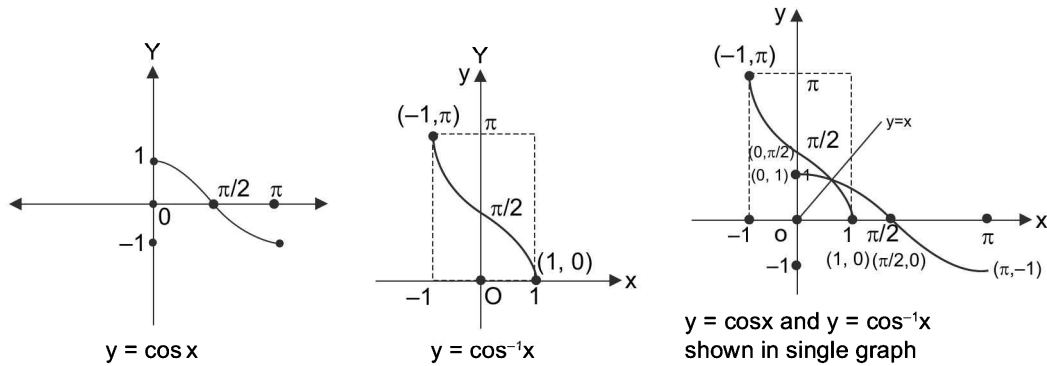

FIGURE 4.3

3.  $y = \tan^{-1}x$ : If  $\tan y = x$  then  $y = \tan^{-1}x$ , under certain conditions. Here  $\tan y \in \mathbb{R} \Rightarrow x \in \mathbb{R} \Rightarrow -\infty < \tan y < \infty \Rightarrow -\pi/2 < y < \pi/2$ . Thus, domain  $x \in \mathbb{R}$ ; Range

$y \in (-\pi/2, \pi/2)$ . To draw the graph of  $y = \tan^{-1}x$ . Sketch  $x = \tan y \forall y \in (-\pi/2, \pi/2)$  or reflect the graph of  $y = \tan x \forall x \in (-\pi/2, \pi/2)$  in line  $y = x$ .

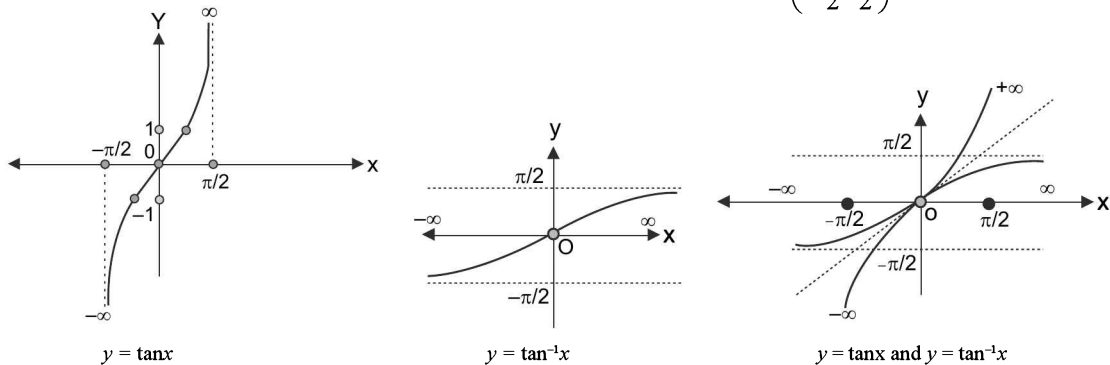

FIGURE 4.4

4.4 > Trigonometry

4.  $y = \cot^{-1}x$ : If  $\cot y = x$ , then  $y = \cot^{-1}x$  (under certain conditions)

$$\cot y \in \mathbb{R} \Rightarrow x \in \mathbb{R}; -\infty < \cot y < \infty \\ \Rightarrow 0 < y < \pi$$

These conditions on  $x$  and  $y$  make the function,  $\cot y = x$  one-one and onto so that the inverse function exists. i.e.,  $y = \cot^{-1}x$  is meaningful. To sketch the graph of  $y = \cot^{-1}x$ , draw  $x = \cot y \forall y \in (0, \pi)$  or reflect  $y = \cot x \forall x \in (0, \pi)$  in line  $y = x$ .

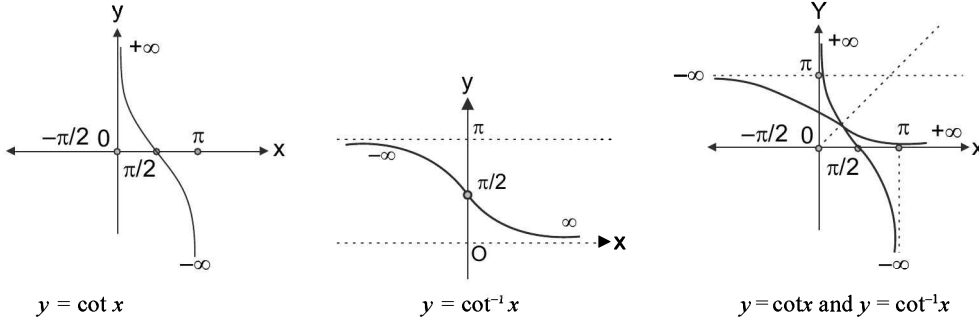

FIGURE 4.5

5.  $y = \sec^{-1}x$ : If  $\sec y = x$ , then  $y = \sec^{-1}x$ , where  $|x| \geq 1$  and

$$0 \leq y \leq \pi, y \neq \pi/2$$

Here, Domain:  $x \in \mathbb{R} - (-1, 1)$ ,

Range:  $y \in [0, \pi] - \{\pi/2\}$ . To obtain  $y = \sec^{-1}x$ , draw  $x = \sec y \forall y \in [0, \pi] - \{\pi/2\}$  or reflect  $y = \sec x \forall x \in [0, \pi] - \{\pi/2\}$  in line  $y = x$ .

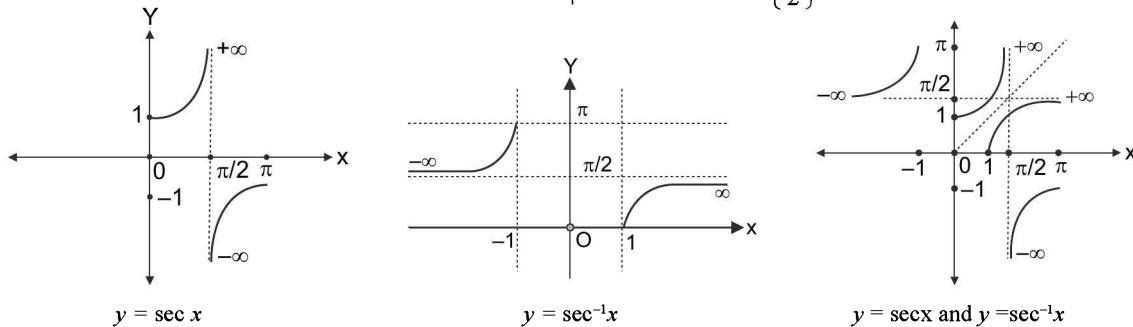

FIGURE 4.6

6.  $y = \operatorname{cosec}^{-1}x$ : If  $\operatorname{cosec} y = x$  then  $y = \operatorname{cosec}^{-1}x$ , where

$$|x| \geq 1 \text{ and } -\pi/2 \leq y \leq \pi/2, y \neq 0$$

Here, Domain:  $\mathbb{R} - (-1, 1)$ ;

Range:  $[-\pi/2, \pi/2] - \{0\}$ . To sketch  $y = \operatorname{cosec}^{-1}x$ , draw  $x = \operatorname{cosec} y \forall y \in [-\pi/2, \pi/2] - \{0\}$  or reflect  $y = \operatorname{cosec} x \forall x \in [-\pi/2, \pi/2] - \{0\}$  in line  $y = x$ .

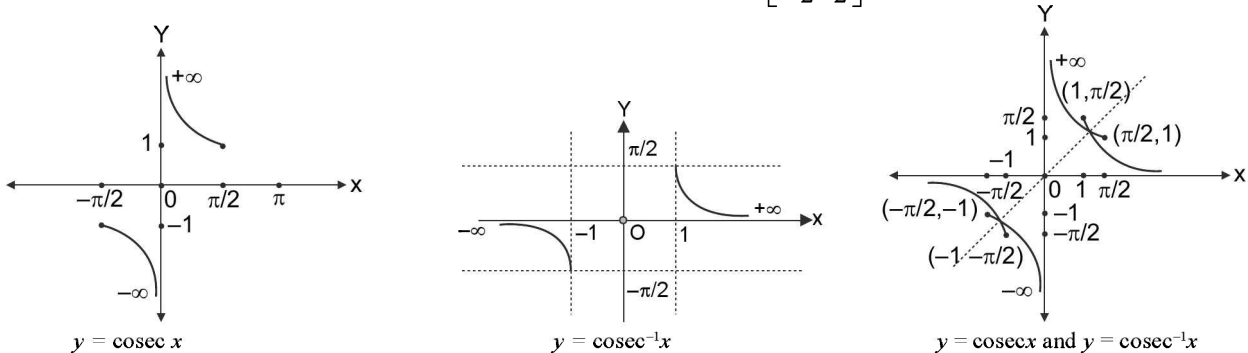

FIGURE 4.7

Table 4.1 Following table shows the domain and range of inverse circular functions

Function	Domain	Range	Principal value branch
$y = \sin^{-1}x$	$[-1, 1]$	$[-\pi/2, \pi/2]$	$-\pi/2 \leq y \leq \pi/2$
$y = \cos^{-1}x$	$[-1, 1]$	$[0, \pi]$	$0 \leq y \leq \pi$
$y = \tan^{-1}x$	$\mathbb{R}$	$(-\pi/2, \pi/2)$	$-\pi/2 < y < \pi/2$
$y = \cot^{-1}x$	$\mathbb{R}$	$(0, \pi)$	$0 < y < \pi$
$y = \sec^{-1}x$	$(-\infty, -1] \cup [1, \infty)$	$[0, \pi] - \{\pi/2\}$	$0 \leq y \leq \pi, y \neq \pi/2$
$y = \operatorname{cosec}^{-1}x$	$(-\infty, -1] \cup [1, \infty)$	$[-\pi/2, \pi/2] - \{0\}$	$-\pi/2 \leq y \leq \pi/2, y \neq 0$

**REMARK**

If no branch of an inverse trigonometric function is mentioned, then it means the principal value branch of the function.

**ILLUSTRATION 1:** Find the principal values of the following:

- (i)  $\cos^{-1}\left(-\frac{1}{\sqrt{2}}\right)$  (ii)  $\operatorname{cosec}^{-1}\left(-\sqrt{2}\right)$   
 (iii)  $\sin^{-1}(-1)$  (iv)  $\tan^{-1}\left(\frac{1}{\sqrt{3}}\right)$

- SOLUTION:**
- (i) Range of  $\cos^{-1}x$  is  $[0, \pi]$   
 for  $x < 0$ ,  $\cos^{-1}x \in (\pi/2, \pi]$ .  
 Let  $\cos^{-1}(-1/\sqrt{2}) = \theta \Rightarrow \cos \theta = (-1/\sqrt{2}) \Rightarrow \theta = (\pi - \pi/4) = 3\pi/4$
- (ii) Range of  $\operatorname{cosec}^{-1}x$  is  $[-\pi/2, \pi/2] - \{0\}$   
 for  $x < 0$ ,  $\operatorname{cosec}^{-1}x \in [-\pi/2, 0)$   
 Let  $\operatorname{cosec}^{-1}(-\sqrt{2}) = \theta \Rightarrow \operatorname{cosec} \theta = -\sqrt{2} \Rightarrow \theta = -\pi/4$
- (iii) Range of  $\sin^{-1}x$  is  $[-\pi/2, \pi/2]$   
 for  $x < 0$ ,  $\sin^{-1}x \in [-\pi/2, 0)$   
 Let  $\sin^{-1}(-1) = \theta \Rightarrow \sin \theta = -1 \Rightarrow \theta = (-\pi/2)$
- (iv) Range of  $\tan^{-1}x$  is  $(-\pi/2, \pi/2)$   
 for  $x > 0$ ,  $\tan^{-1}x \in (0, \pi/2)$   
 Let  $\tan^{-1}(1/\sqrt{3}) = \theta \Rightarrow \tan \theta = 1/\sqrt{3} \Rightarrow \theta = (\pi/6)$

**ILLUSTRATION 2:** Find the value of

- (i)  $\tan^{-1}(\sqrt{3}) + \tan^{-1}\left(-\frac{1}{\sqrt{3}}\right) + \tan^{-1}(1)$  (ii)  $\sin^{-1}(1) + \cos^{-1}(1) + \tan^{-1}(1)$   
 (iii)  $\sin^{-1}(1/2) + \cos^{-1}\left(\frac{1}{\sqrt{2}}\right) - \tan^{-1}\left(-\frac{1}{\sqrt{3}}\right)$  (iv)  $2\sec^{-1}(2) - 3\sin^{-1}\left(-\frac{1}{2}\right) + \cot^{-1}(\sqrt{3})$

- SOLUTION:**
- (i)  $\tan^{-1}(\sqrt{3}) + \tan^{-1}\left(-\frac{1}{\sqrt{3}}\right) + \tan^{-1}1 = \frac{\pi}{3} + \left(-\frac{\pi}{6}\right) + \frac{\pi}{4} = \frac{\pi}{6} + \frac{\pi}{4} = \frac{5\pi}{12}$
- (ii)  $\sin^{-1}1 + \cos^{-1}1 + \tan^{-1}1 = \frac{\pi}{2} + 0 + \frac{\pi}{4} = \frac{\pi}{2} + \frac{\pi}{4} = \frac{3\pi}{4}$

$$(iii) \sin^{-1}\left(\frac{1}{2}\right) + \cos^{-1}\left(\frac{1}{\sqrt{2}}\right) - \tan^{-1}\left(-\frac{1}{\sqrt{3}}\right) = \frac{\pi}{6} + \frac{\pi}{4} - \left(-\frac{\pi}{6}\right) = \frac{\pi}{6} + \frac{\pi}{4} + \frac{\pi}{6} = \frac{7\pi}{12}$$

$$(iv) 2\sec^{-1}(2) - 3\sin^{-1}\left(-\frac{1}{2}\right) + \cot^{-1}(\sqrt{3}) = 2\left(\frac{\pi}{3}\right) - 3\left(-\frac{\pi}{6}\right) + \left(\frac{\pi}{6}\right)$$

$$= \frac{2\pi}{3} + \frac{\pi}{2} + \frac{\pi}{6} = \frac{4\pi + 3\pi + \pi}{6} = \frac{4\pi}{3}$$

**ILLUSTRATION 3:** If  $\sum_{i=1}^{2n} \cos^{-1} x_i = 0$ , then find the value of  $\sum_{i=1}^{2n} x_i$ .

**SOLUTION:**  $\because \cos^{-1} x_i \in [0, \pi] \forall i \in \{1, 2, 3, \dots, n\}$

$\therefore \sum_{i=1}^{2n} \cos^{-1} x_i = 0$  is possible only when  $\cos^{-1} x_i = 0 \forall i$  as all term are non-negative

$\therefore x_i = 1 \forall i \in \{1, 2, 3, \dots, n\}$

$\therefore \sum_{i=1}^{2n} x_i = \sum_{i=1}^{2n} 1 = 2n$

**ILLUSTRATION 4:** If  $\sin^{-1} x + \sin^{-1} y + \sin^{-1} z = \frac{3\pi}{2}$ , then find the value of  $x^{100} + y^{100} + z^{100} - \frac{3}{x^{101} + y^{101} + z^{101}}$ .

**SOLUTION:**  $\because \sin^{-1} \theta \in \left[-\frac{\pi}{2}, \frac{\pi}{2}\right]$

$\therefore \sin^{-1} x + \sin^{-1} y + \sin^{-1} z = \frac{3\pi}{2}$  is possible only when  $\sin^{-1} x = \sin^{-1} y = \sin^{-1} z = \frac{\pi}{2}$

$\Rightarrow x = y = z = 1$

$\therefore x^{100} + y^{100} + z^{100} - \frac{3}{x^{101} + y^{101} + z^{101}} = 1 + 1 + 1 - \frac{3}{1+1+1} = 3 - \frac{3}{3} = 3 - 1 = 2$

**ILLUSTRATION 5:** If  $\sin^{-1}(x-1) + \cos^{-1}(x-3) + \tan^{-1}\left(\frac{x}{2-x^2}\right) = \cos^{-1} k + \pi$ , then find the value of  $k$ .

**SOLUTION:** First of all analysing the domain of expression we get, for  $\sin^{-1}(x-1)$ ;  $-1 \leq x-1 \leq 1$

$\Rightarrow 0 \leq x \leq 2$  ....(i)

For;  $\cos^{-1}(x-3)$ ;  $-1 \leq x-3 \leq 1$

$\Rightarrow 2 \leq x \leq 4$  ....(ii)

$\therefore$  From (i) and (ii) clearly,  $x = 2$

$$\therefore \sin^{-1}(x-1) + \cos^{-1}(x-3) + \tan^{-1}\left(\frac{x}{2-x^2}\right) = \sin^{-1} 1 + \cos^{-1}(-1) + \tan^{-1}(-1)$$

$$= \frac{\pi}{2} + \pi - \frac{\pi}{4} = \frac{3\pi}{2} - \frac{\pi}{4} = \frac{6\pi - \pi}{4} = \frac{5\pi}{4}$$

$$\therefore A.T.Q: \frac{5\pi}{4} = \cos^{-1} k + \pi$$

$$\Rightarrow \cos^{-1} k = \frac{5\pi}{4} - \pi = \frac{\pi}{4} \qquad \Rightarrow k = \cos \frac{\pi}{4}$$

$$\Rightarrow k = \frac{1}{\sqrt{2}}$$

**ILLUSTRATION 6:** Find the solution set of inequality  $\log_{1/2} \sin^{-1}x > \log_{1/2} \cos^{-1}x$ .

**SOLUTION:**  $\log_{1/2} \sin^{-1}x > \log_{1/2} \cos^{-1}x$  ... (i) is valid when  $\sin^{-1}x, \cos^{-1}x > 0$ , therefore  $\sin^{-1}x, \cos^{-1}x \in (0, \pi/2)$   
 $\Rightarrow x \in (0, 1)$

Now from (i)  $\sin^{-1}x < \cos^{-1}x$  for  $x \in (0, 1)$

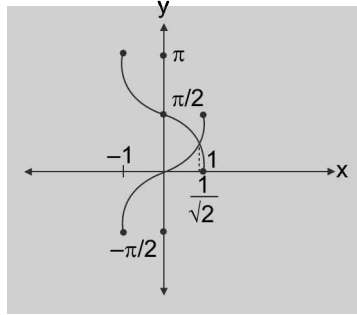

**FIGURE 4.8**

$\therefore \cos^{-1}x > \sin^{-1}x$ , where  $x \in (0, 1)$  has solution set  $x \in \left(0, \frac{1}{\sqrt{2}}\right)$  as observed from the graph.

**Aliter:**  $\sin^{-1}x < \cos^{-1}x \Rightarrow \sin^{-1}x < \frac{\pi}{2} - \sin^{-1}x \Rightarrow \sin^{-1}x < \frac{\pi}{4} \Rightarrow 0 < \sin^{-1}x < \frac{\pi}{4}$

Operating same, we get  $0 < x < \frac{1}{\sqrt{2}}$

**ILLUSTRATION 7:** Show that  $\cos [\cos^{-1}x + \sin^{-1}(x-2)] = 0$ .

**Proof:**  $\cos^{-1}x$  is defined for  $x \in [-1, 1]$  .....(i)

and  $\sin^{-1}(x-2)$  is defined for  $-1 \leq x-2 \leq 1 \Rightarrow 1 \leq x \leq 3$  .....(ii)

$\therefore \cos^{-1}x + \sin^{-1}(x-2)$  is defined for  $x = 1$  only

$\therefore \cos(\cos^{-1}x + \sin^{-1}(x-2)) = \cos[\cos^{-1}1 + \sin^{-1}(-1)]$   
 $= \cos[0 - \pi/2] = \cos\pi/2 = 0$

Hence proved.

**ILLUSTRATION 8:** Find the real values of  $x$  for which the equation  $\cos^{-1}\sqrt{x-1} = \sin^{-1}\sqrt{2-x}$  holds good.

**SOLUTION:** The given equation is meaningful for  $0 \leq \sqrt{x-1} \leq 1$ ;  $x-1 \geq 0$

and  $0 \leq \sqrt{2-x} \leq 1$ ;  $2-x \geq 0$

$\Rightarrow 0 \leq x-1 \leq 1$ ;  $x \geq 1$  and  $0 \leq 2-x \leq 1$ ;  $x \leq 2$

$\Rightarrow 1 \leq x \leq 2$ ;  $x \geq 1$  and  $1 \leq x \leq 2$ ;  $x \leq 2$

$\Rightarrow 1 \leq x \leq 2$

Now let  $\cos^{-1}\sqrt{x-1} = \theta \in \left[0, \frac{\pi}{2}\right]$  .....(i)

$\Rightarrow \sqrt{x-1} = \cos\theta$

$\Rightarrow \sin\theta = \sqrt{1-\cos^2\theta}$  as  $\theta \in \left[0, \frac{\pi}{2}\right] = \sqrt{1-(x-1)} = \sqrt{2-x}$

$\Rightarrow \theta = \sin^{-1}\sqrt{2-x}$

$\Rightarrow \cos^{-1}\sqrt{x-1} = \sin^{-1}\sqrt{2-x}$ ; which is always true  $\forall 1 \leq x \leq 2$

$\therefore [1, 2]$

**ILLUSTRATION 9:** Find the subset of set of real numbers in which  $\cos^{-1}(x-1) > \cos^{-1}(2x+1)$ .

**SOLUTION:** The given inequality holds for  $x-1 \in [-1, 1]$  and  $2x+1 \in [-1, 1]$  and  $x-1 < (2x+1)$  as  $y = \cos^{-1}x$  is a decreasing function

$$\therefore -1 \leq x-1 \leq 1 \text{ and } -1 \leq 2x+1 \leq 1 \text{ and } x > -2$$

$$\Rightarrow 0 \leq x \leq 2 \text{ and } -1 \leq x \leq 0 \text{ and } x > -2 \text{ (taking intersection of sets)}$$

$$\Rightarrow x = 0$$

$$\therefore \{0\}$$

**ILLUSTRATION 10:** If  $\tan(x+y) = 33$ ;  $x = \tan^{-1}(3)$ , then evaluate  $y$

**SOLUTION:**  $\tan(x+y) = \frac{\tan x + \tan y}{1 - \tan x \tan y}$

$$\therefore x = \tan^{-1} 3 \text{ i.e., } \tan x = 3$$

$$\therefore \tan(x+y) = \frac{3 + \tan y}{1 - 3 \tan y}$$

$$\Rightarrow 33 = \frac{3 + \tan y}{1 - 3 \tan y}$$

$$\Rightarrow 33 - 99 \tan y = 3 + \tan y$$

$$\Rightarrow \tan y = \frac{3}{10} = 0.3 \text{ i.e., } y = \tan^{-1}(0.3)$$

**ILLUSTRATION 11:** Find the domain of definition of the following functions. (Read the symbols  $[*]$  and  $\{*\}$  as greatest integers and fractional part functions respectively.)

(i)  $f(x) = \arccos \frac{2x}{1+x}$

(ii)  $f(x) = \sqrt{\cos(\sin x)} + \sin^{-1} \frac{1+x^2}{2x}$

(iii)  $f(x) = \sin^{-1} \left( \frac{x-3}{2} \right) - \log_{10}(4-x)$

(iii)  $f(x) = \log_{10}(1 - \log_7(x^2 - 5x + 13)) + \cos^{-1} \left( \frac{1}{2 + \sin \frac{9\pi x}{2}} \right)$

(iv)  $f(x) = e^{\sin^{-1} \left( \frac{x}{2} \right)} + \tan^{-1} \left[ \frac{x}{2} - 1 \right] + \ln(\sqrt{x - [x]})$

**SOLUTION:** (i)  $f(x) = \arccos \left( \frac{2x}{1+x} \right)$  to be defined  $-1 \leq \frac{2x}{1+x} \leq 1$

$$\Rightarrow \frac{2x}{x+1} + 1 \geq 0 \text{ and } \frac{2x}{x+1} - 1 \leq 0$$

$$\Rightarrow \frac{3x+1}{x+1} \geq 0 \text{ and } \frac{x-1}{x+1} \leq 0$$

$$\Rightarrow x \in (-1, 1] \text{ and } x \in (-\infty, -1) \cup [-1/3, \infty)$$

Now taking intersection we get, domain  $\left[-\frac{1}{3}, 1\right]$

(ii)  $f(x) = \sqrt{\cos(\sin x)} + \sin^{-1}\left(\frac{1+x^2}{2x}\right)$  to be defined  $\cos(\sin x) \geq 0$  and  $-1 \leq \frac{1+x^2}{2x} \leq 1$

$$x \in \mathbb{R} \text{ and } x \in \{-1, 1\}$$

$\because \sin x \in [-1, 1] \forall x \in \mathbb{R} \cos x > 0 \forall x \in [-1, 1]$  and solving other inequality we get  $x \in \{-1, 1\}$  and taking intersection we get, domain  $\{-1, 1\}$

(iii)  $f(x) = \sin^{-1}\left(\frac{x-3}{2}\right) - \log_{10}(4-x)$  to be real and finite

$$-1 \leq \frac{x-3}{2} \leq 1 \text{ and } 4-x > 0$$

$$-2 \leq x-3 \leq 2 \text{ and } x < 4$$

$$1 \leq x \leq 5 \text{ and } x < 4, \text{ therefore domain : } [1, 5] \cap (-\infty, 4) = [1, 4)$$

(iv)  $f(x) = \log_{10}(1 - \log_7(x^2 - 5x + 13)) + \cos^{-1}\left(\frac{1}{2 + \sin \frac{9\pi x}{2}}\right)$

$$1 - \log_7(x^2 - 5x + 13) > 0 \text{ and } x^2 - 5x + 13 > 0 \text{ and } \frac{1}{2 + \sin \frac{9\pi x}{2}} \in [-1, 1] \text{ (always hold)}$$

$$\begin{aligned} &\log_7(x^2 - 5x + 13) < 1; \because 1 = \log_7 7 \\ \Rightarrow &x^2 - 5x + 13 < 7 \because \log_7 x \text{ is increasing function} \\ \Rightarrow &x^2 - 5x + 6 < 0 \\ \Rightarrow &(x-3)(x-2) < 0 \\ \Rightarrow &x \in (2, 3) \\ &\text{Also } x^2 - 5x + 13 > 0 \\ &\forall x \in \mathbb{R} \text{ as } a = 1 > 0 \text{ and } D < 0 \end{aligned} \quad \left[ \begin{aligned} &\because \sin \frac{9\pi x}{2} \in [-1, 1] \\ \Rightarrow &2 + \sin \frac{9\pi x}{2} \in [1, 3] \\ \Rightarrow &\frac{1}{2 + \sin \frac{9\pi x}{2}} \in \left[\frac{1}{3}, 1\right] \subseteq [-1, 1] \end{aligned} \right]$$

Taking intersection of sets we get,  $2 < x < 3 \Rightarrow$  Domain of  $f(x) = (2, 3)$

(v)  $f(x) = e^{\sin^{-1}\left(\frac{x}{2}\right)} + \tan^{-1}\left[\frac{x}{2} - 1\right] + \ln(\sqrt{x - [x]})$  to be real and finite each term must be real and finite

$$\Rightarrow -1 \leq \frac{x}{2} \leq 1 \text{ and } \left[\frac{x}{2} - 1\right] \in \mathbb{R} \text{ and } x - [x] > 0$$

$$\Rightarrow -2 \leq x \leq 2 \text{ and } x \in \mathbb{R} \text{ and } x > [x] \Rightarrow x \in \mathbb{R} \sim \mathbb{Z}$$

Taking intersection of above three sets  $x \in (-2, 2) \sim \{-1, 0, 1\}$  is domain of  $f(x)$



**ILLUSTRATION 12:** Solve the following inequalities:

(i)  $\cos^{-1} x > \cos^{-1} x^2$

(ii)  $\tan^{-1} x > \cot^{-1} x$

**SOLUTION:**  $\cos^{-1} x > \cos^{-1} x^2$  as both  $\cos^{-1} x$  and  $\cos^{-1} x^2$  are defined for  $x \in [-1, 1]$  and  $\cos x$  is decreasing function  $\forall x \in [0, \pi]$

$\Rightarrow x < x^2$  i.e.,  $x^2 - x > 0$  i.e.,  $x(x - 1) > 0$

$\Rightarrow x \in (-\infty, 0) \cup (1, \infty)$

Now taking  $\cap$  of both sets we get solution set as  $[-1, 0)$ .

(ii)  $\tan^{-1} x > -\tan^{-1} x \quad \because \tan\left(\frac{\pi}{2} - \theta\right) = \cot \theta \Rightarrow \tan^{-1} x + \cot^{-1} x = \frac{\pi}{2}$

$\Rightarrow \tan^{-1} x > \frac{\pi}{4}$

$\Rightarrow x > \tan \frac{\pi}{4}$  i.e.,  $x > 1 \Rightarrow$  Domain of inequality =  $(1, \infty)$

**ILLUSTRATION 13:** Find the domain of function  $f(x) = \sqrt{3\pi \tan^{-1} x - 4(\tan^{-1} x)^3}$

**SOLUTION:**  $3\pi \tan^{-1} x - 4(\tan^{-1} x)^3 \geq 0$

$\Rightarrow (\tan^{-1} x) [3\pi - 4(\tan^{-1} x)^2] \geq 0$

Let  $\tan^{-1} x = t$

$\Rightarrow t [3\pi - 4t^2] \geq 0 \Rightarrow t(2t - \sqrt{3\pi})(2t + \sqrt{3\pi}) \leq 0$

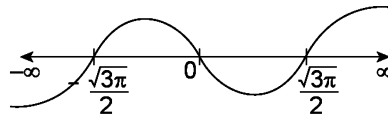

FIGURE 4.10

$\Rightarrow t \in \left(-\infty, \frac{-\sqrt{3\pi}}{2}\right] \cup \left[0, \frac{\sqrt{3\pi}}{2}\right]$

Also  $t = \tan^{-1} x \in \left(-\frac{\pi}{2}, \frac{\pi}{2}\right)$

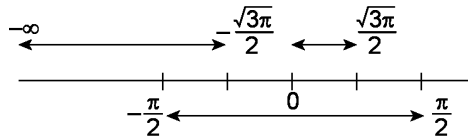

FIGURE 4.11

$\therefore \tan^{-1} x = t \in \left(-\frac{\pi}{2}, \frac{-\sqrt{3\pi}}{2}\right] \cup \left[0, \frac{\sqrt{3\pi}}{2}\right]$

$\therefore \tan^{-1} x$  is an increasing function and  $x$  is also increasing in  $\left(-\frac{\pi}{2}, \frac{\pi}{2}\right)$

$$\Rightarrow x \in \left( -\infty, \tan\left(\frac{-\sqrt{3}\pi}{2}\right) \right] \cup \left[ 0, \tan\left(\frac{\sqrt{3}\pi}{2}\right) \right]$$

$$\Rightarrow x \in \left( -\infty, -\tan\frac{\sqrt{3}\pi}{2} \right] \cup \left[ 0, \tan\frac{\sqrt{3}\pi}{2} \right]$$

**ILLUSTRATION 14:** Find the domain of the function  $f(x) = \frac{\sin^{-1}x}{[x^2]}$ .

**SOLUTION:** Domain of  $\sin^{-1}x = [-1, 1]$  .....(i)

and  $[x^2] > 0 \Rightarrow x^2 \notin [0, 1]$

$\Rightarrow x \notin (-1, 1) \Rightarrow x = \pm 1$  .....(ii)

From (i) and (ii), we get domain of  $f(x) = \{-1, 1\}$

**ILLUSTRATION 15:** Find the range of the function  $f(x) = \frac{\sin^{-1}x}{[x^2]}$ .

**SOLUTION:** Clearly, the domain of function  $f(x) = \{-1, 1\}$  as found in above illustration,

$\therefore f(x) = \sin^{-1}x; x = \pm 1$

$\therefore$  Range of  $f(x) = \{\sin^{-1}(-1), \sin^{-1}(1)\} = \left\{-\frac{\pi}{2}, \frac{\pi}{2}\right\}$

**ILLUSTRATION 16:** Find the range of the function  $f(x) = 3\sin^{-1}(-x^2) + \pi$ .

**SOLUTION:**  $\because -x^2 \in [-1, 1];$

$\Rightarrow -x^2 \in [-1, 0]$

$\Rightarrow \sin^{-1}(-1) \leq \sin^{-1}(-x^2) \leq \sin^{-1}(0)$  as  $\sin^{-1}x$  is an increasing function

$\therefore -\frac{\pi}{2} \leq \sin^{-1}(-x^2) \leq 0$

$\Rightarrow -\frac{3\pi}{2} \leq 3\sin^{-1}(-x^2) \leq 0$

$\Rightarrow -\frac{\pi}{2} \leq 3\sin^{-1}(-x^2) + \pi \leq \pi$

$\Rightarrow f(x) \in \left[-\frac{\pi}{2}, \pi\right] \Rightarrow$  Range of  $f(x)$  is  $\left[-\frac{\pi}{2}, \pi\right]$

**ILLUSTRATION 17:** Solve the inequalities  $6(\cos^{-1}x)^2 + \pi \cos^{-1}x - \pi^2 \geq 0$

**SOLUTION:** Factorizing the expression we get,  $(3\cos^{-1}x - \pi)(2\cos^{-1}x + \pi) \geq 0$

$\Rightarrow \cos^{-1}x \leq \frac{-\pi}{2}$  or  $\cos^{-1}x \geq \pi/3$

But  $\cos^{-1}x \in [0, \pi]$ , therefore  $\cos^{-1}x \in \left[\frac{\pi}{3}, \pi\right]$  i.e.,  $\frac{\pi}{3} \leq \cos^{-1}x \leq \pi$

$\Rightarrow x \in \left[\cos\pi, \cos\frac{\pi}{3}\right]$  as  $\cos^{-1}x$  is a decreasing function

$\Rightarrow x \in \left[-1, \frac{1}{2}\right]$

**ILLUSTRATION 18:** Solve the inequality  $(\sec^{-1} x)^2 - 7(\sec^{-1} x) + 12 \geq 0$

**SOLUTION:** Factorizing the expression we get,  $(\sec^{-1} x - 3)(\sec^{-1} x - 4) \geq 0$

$$\Rightarrow \sec^{-1} x \leq 3 \text{ or } \sec^{-1} x \geq 4$$

$$\text{But } \sec^{-1} x \in [0, \pi] \sim \left\{ \frac{\pi}{2} \right\}$$

$$\Rightarrow \sec^{-1} x \in [0, 3] \sim \left\{ \frac{\pi}{2} \right\}$$

$$\Rightarrow 0 \leq \sec^{-1} x \leq 3, \sec^{-1} x \neq \frac{\pi}{2}$$

$$\Rightarrow \sec^{-1} x \in \left[ 0, \frac{\pi}{2} \right) \cup \left( \frac{\pi}{2}, 3 \right]$$

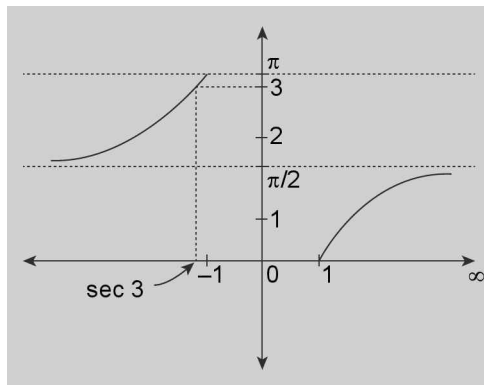

**FIGURE 4.12**

$$\Rightarrow x \in (-\infty, \sec 3] \cup [1, \infty) \text{ as is clear from figure given above.}$$

**ILLUSTRATION 19:** Solve the inequality  $4(\cot^{-1} x)^2 - 16(\cot^{-1} x) + 15 \leq 0$ .

**SOLUTION:** Let  $\cot^{-1} x = t$ , the inequality becomes

$$\Rightarrow 4t^2 - 16t + 15 \leq 0$$

$$\Rightarrow 4t^2 - 10t - 6t + 15 \leq 0$$

$$\Rightarrow (2t - 5)(2t - 3) \leq 0$$

$$\Rightarrow \frac{3}{2} \leq t \leq \frac{5}{2}$$

$$\Rightarrow \cot^{-1} x \in \left[ \frac{3}{2}, \frac{5}{2} \right], \text{ Also } \cot^{-1} x \in (0, \pi) \text{ and } \left[ \frac{3}{2}, \frac{5}{2} \right] \subset (0, \pi)$$

and  $\cot^{-1} x$  is a decreasing function in  $(0, \pi)$

$$\Rightarrow x \in \left[ \cot \frac{5}{2}, \cot \frac{3}{2} \right]$$

**TEXTUAL EXERCISE-1 SUBJECTIVE**

1. Find the principal values of the following:

(a)  $\sin^{-1}\left(-\frac{1}{2}\right)$       (b)  $\cos^{-1}\left(\frac{\sqrt{3}}{2}\right)$

(c)  $\operatorname{cosec}^{-1}(2)$       (d)  $\tan^{-1}(-\sqrt{3})$

(e)  $\cos^{-1}\left(-\frac{1}{2}\right)$       (f)  $\tan^{-1}(-1)$

(g)  $\sec^{-1}\left(\frac{2}{\sqrt{3}}\right)$       (h)  $\cot^{-1}(-\sqrt{3})$

2. Find the values of the following:

(a)  $\tan^{-1}(1) + \cos^{-1}\left(-\frac{1}{2}\right) + \sin^{-1}\left(-\frac{1}{2}\right)$

(b)  $\cos^{-1}\left(\frac{1}{2}\right) + 2 \sin^{-1}\left(\frac{1}{2}\right)$

(c)  $\tan^{-1}\sqrt{3} - \sec^{-1}(-2)$

3. If  $\cos^{-1}x_1 + \cos^{-1}x_2 + \dots + \cos^{-1}x_k = k\pi$  then evaluate A.M of  $x_p$  s.

4. If  $\sum_{i=1}^n (\sin^{-1}x_i + \cos^{-1}y_i) = \frac{3n\pi}{2}$  then evaluate

(i)  $\sum_{i=1}^n x_i$       (ii)  $\sum_{i=1}^n y_i$

(iii)  $\sum_{i=1}^n x_i y_i$       (iv)  $\sum_{i=1}^n (x_i + y_i)$

(v)  $\sum_{1 \leq i < j \leq n} x_i y_j$

5. Find the domain of definition the following functions.

(Read the symbols  $[*]$  and  $\{*\}$  as greatest integers and fractional part functions respectively.)

(i)  $f(x) = \sin^{-1}(2x + x^2)$

(ii)  $f(x) = \frac{\sqrt{1 - \sin x}}{\log_5(1 - 4x^2)} + \cos^{-1}(1 - \{x\})$ , where  $\{x\}$  is the fractional part of  $x$ .

(iii)  $f(x) = \sqrt{3-x} + \cos^{-1}\left(\frac{3-2x}{5}\right) +$

$\log_6(2|x| - 3) + \sin^{-1}(\log_2 x)$

(iv)  $f(x) = \sqrt{\sin(\cos x)} + \ln(-2\cos^2 x +$

$3\cos x - 1) + e^{\cos^{-1}\left(\frac{2\sin x + 1}{2\sqrt{2}\sin x}\right)}$

6. Find the domain of the function given by

(a)  $f(x) = \cos^{-1}\frac{3}{3 + \sin x}$

(b)  $\sin^{-1}(\log_2(x^2 + 3x + 4))$

7. Find the domain and range of the following functions.

(i)  $f(x) = \cos^{-1}(2x - x^2)$

(ii)  $f(x) = \tan^{-1}\left(\log_{\frac{4}{25}}(5x^2 - 8x + 4)\right)$

8. Find the domain and range of the following functions:

(i)  $y = \cos^{-1}[x]$       (ii)  $y = \sin^{-1}(e^x)$

(iii)  $y = \cos^{-1}\{x\}$       (iv)  $y = \sin^{-1}\{x\}$

(v)  $y = \cot^{-1}(\operatorname{sgn} x)$

9. If  $\alpha = \sin^{-1}\left(\frac{36}{85}\right)$ ;  $\beta = \cos^{-1}\left(\frac{4}{5}\right)$ ;  $\gamma = \tan^{-1}\left(\frac{8}{15}\right)$ ;

then prove that

(i)  $\sum \cot \alpha = \pi \cot \alpha$

(ii)  $\sum \tan \alpha \cdot \tan \beta = 1$

10. If  $\cos^{-1} \frac{n}{\pi} > \frac{\pi}{6}$ ,  $n \in \mathbb{N}$  then find the maximum value of  $n$ .

11. Evaluate:  $\cos^{-1} \left[ \lim_{n \rightarrow \infty} \left\{ \frac{1}{\sum_{k=0}^n \frac{1}{2^k}} \right\} \right]$

12. (a) Solve the equation:  $2(\sin^{-1} x)^2 - (\sin^{-1} x) - 6 = 0$ .

(b) Find smallest and the largest values of  $\tan^{-1}\left(\frac{1-x}{1+x}\right)$ ,

$0 \leq x \leq 1$  and therefore the range of function.

13. Prove that:  $\tan\left[\frac{\pi}{4} + \frac{1}{2}\cos^{-1}\left(\frac{a}{b}\right)\right] +$

$\tan\left[\frac{\pi}{4} - \frac{1}{2}\cos^{-1}\left(\frac{a}{b}\right)\right] = \frac{2b}{a}$

14. Find the solution set of inequality

$(\cot^{-1}x)^2 - 5\cot^{-1}x + 6 > 0$

15. Find the value of 'a' for which the quadratic equation  $ax^2 + \sin^{-1}(x^2 - 2x + 2) + \cos^{-1}(x^2 - 2x + 2) = 0$  has a real solution.

4.14 > Trigonometry

16. Find the domain of the following functions:

(i)  $y = \sec^{-1}(x^2 + 3x + 1)$

(ii)  $y = \cos^{-1}\left(\frac{x^2}{1+x^2}\right)$

(iii)  $y = \tan^{-1}(\sqrt{x^2 - 1})$

17. Draw the graphs of the following:

(i)  $y = \sin^{-1}(x + 1)$

(ii)  $y = \cos^{-1}(3x)$

(iii)  $y = \tan^{-1}(2x-1)$

18. Solve  $\tan^2(\arcsin x) > 1$

19. Find the intervals in which

(i)  $\tan^{-1}x > \cot^{-1}x$

(ii)  $\cot^{-1}x > \tan^{-1}x$

(iii)  $\sin^{-1}x > \cos^{-1}x$

(iv)  $\cos^{-1}x > \sin^{-1}x$

20. Let  $f(x) = \cot^{-1}(x^2 + 4x + \alpha^2 - \alpha)$  be a function defined  $R \rightarrow (0, \pi/2]$ , then find the complete set of real values of  $\alpha$  for which  $f(x)$  is onto.

## Answer Keys

1. (a)  $\frac{-\pi}{6}$  (b)  $\frac{\pi}{6}$  (c)  $\frac{\pi}{6}$  (d)  $\frac{-\pi}{3}$  (e)  $\frac{2\pi}{3}$  (f)  $\frac{-\pi}{4}$  (g)  $\frac{\pi}{6}$  (h)  $\frac{5\pi}{6}$

2. (a)  $\frac{3\pi}{4}$  (b)  $\frac{2\pi}{3}$  (c)  $\frac{-\pi}{3}$  3. -1

4. (i)  $n$  (ii)  $-n$  (iii)  $-n$  (iv) 0 (v)  ${}^nC_2$  or  $-n(n-1)/2$

5. (i)  $[-1-\sqrt{2}, -1+\sqrt{2}]$  (ii)  $x \in \left(-\frac{1}{2}, \frac{1}{2}\right) - \{0\}$  (iii)  $\left(\frac{3}{2}, 2\right]$  (iv)  $\left\{x : x = 2n\pi + \frac{\pi}{6}, n \in \mathbb{Z}\right\}$

6. (a)  $\bigcup_{n \in \mathbb{Z}} [2n\pi, (2n+1)\pi]$  (b)  $[-2, -1]$

7. (i) Domain =  $[1-\sqrt{2}, 1+\sqrt{2}]$ , Range =  $[0, \pi]$  (ii) Domain =  $\mathbb{R}$ , Range =  $(-\pi/2, \pi/4]$

8. (i)  $D_f : [-1, 2)$  and  $R_f : \left\{0, \frac{\pi}{2}, \pi\right\}$  (ii)  $D_f : (-\infty, 0]$  and  $R_f : \left(0, \frac{\pi}{2}\right]$  (iii)  $D_f : \mathbb{R}$  and  $R_f : \left[0, \frac{\pi}{2}\right)$

(iv)  $D_f : \mathbb{R}$  and  $R_f : \left[0, \frac{\pi}{2}\right)$  (v)  $D_f : \mathbb{R}$  and  $R_f : \left\{\frac{\pi}{2}, \frac{\pi}{4}, \frac{3\pi}{4}\right\}$

10. 2 11.  $\pi/3$  12. (a)  $x = -\sin\left(\frac{3}{2}\right)$  (b)  $\left[0, \frac{\pi}{4}\right]$

14.  $(-\infty, \cot 3) \cup (\cot 2, \infty)$

15.  $-\pi/2$  16. (i)  $(-\infty, -3] \cup [-2, -1] \cup [0, \infty)$  (ii)  $\mathbb{R}$  (iii)  $(-\infty, -1] \cup [1, \infty)$

17.

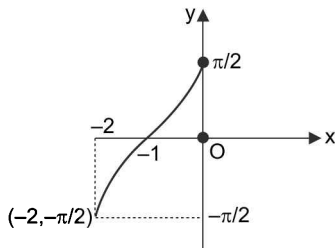

(i)

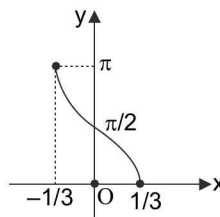

(ii)

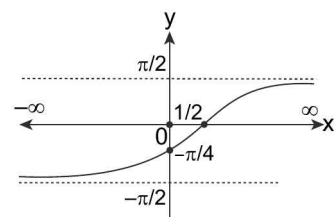

(iii)

18.  $\left(-1, \frac{-1}{\sqrt{2}}\right) \cup \left(\frac{1}{\sqrt{2}}, 1\right)$

19.

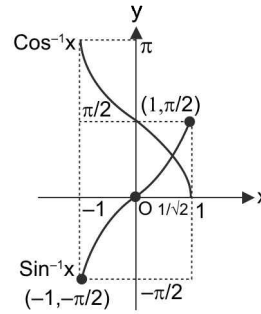
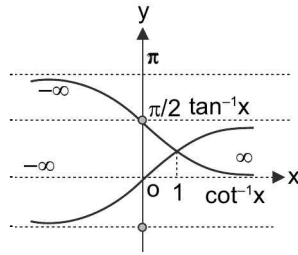

(i)  $\tan^{-1}x > \cot^{-1}x$  for  $x \in (1, \infty)$

(ii)  $\cot^{-1}x > \tan^{-1}x$  for  $x \in (-\infty, 1)$

(iii)  $\sin^{-1}x > \cos^{-1}x$  for  $x \in \left(\frac{1}{\sqrt{2}}, 1\right)$

(iv)  $\cos^{-1}x > \sin^{-1}x$  for  $x \in \left[-1, \frac{1}{\sqrt{2}}\right]$

20.  $\alpha = \frac{1 \pm \sqrt{17}}{2}$

**TEXTUAL EXERCISE-1 (OBJECTIVE)**

 1. The value of  $\sin^{-1}\left(\frac{\sqrt{3}}{2}\right) + \sin^{-1}\left(\frac{1}{\sqrt{2}}\right)$  is equal to

- (a)  $75^\circ$  (b)  $105^\circ$   
 (c)  $\frac{5\pi}{12}$  (d)  $\frac{3\pi}{5}$

 2. The value of  $\sin\left(\frac{\pi}{3} - \sin^{-1}\left(\frac{-1}{2}\right)\right)$  is

- (a)  $\frac{1}{2}$  (b)  $\frac{1}{3}$   
 (c)  $\frac{1}{4}$  (d) 1.

 3. The principal value of  $\cos^{-1}\left(\cos\frac{2\pi}{3}\right) + \sin^{-1}$ 
 $\left(\sin\frac{2\pi}{3}\right)$  is

- (a)  $\pi$  (b)  $\frac{\pi}{2}$   
 (c)  $\frac{\pi}{3}$  (d)  $\frac{4\pi}{3}$

 4.  $\operatorname{cosec}^{-1}(\cos x)$  is real if

- (a)  $x \in [-1, 1]$   
 (b)  $x \in R$

 (c)  $x$  is an odd multiple of  $\pi$ 

 (d)  $x$  is integer multiple of  $\pi$ 

 5. If  $\sum_{i=1}^n \cos^{-1} \alpha_i = 0$ , then  $\sum_{i=1}^n \alpha_i$ 

- (a)  $n$  (b)  $-n$   
 (c) 0 (d) None of these

 6. If  $\sin^{-1}x + \sin^{-1}y + \sin^{-1}z = \frac{3\pi}{2}$ , then

- (a)  $x^{100} + y^{100} + z^{100} - \frac{9}{x^{101} + y^{101} + z^{101}} = 0$   
 (b)  $x^{22} + y^{42} + z^{62} - x^{220} - y^{420} - z^{620} = 0$   
 (c)  $x^{50} + y^{25} + z^6 = 0$   
 (d)  $\frac{x^{2008} + y^{2008} + z^{2008}}{(xyz)^{2009}} = 0$

 7. If  $A = 2 \tan^{-1}(2\sqrt{2}-1)$  and  $B = 3 \sin^{-1}\left(\frac{1}{3}\right) + \sin^{-1}\left(\frac{3}{5}\right)$  then

- (a)  $A > B$  (b)  $A < B$   
 (c)  $A = B$  (d) can't be decided

 8. Domain of  $f(x) = \cos^{-1}x + \cot^{-1}x + \operatorname{cosec}^{-1}x$  is

- (a)  $[-1, 1]$  (b)  $R$   
 (c)  $(-\infty, -1] \cup [1, \infty)$  (d)  $\{-1, 1\}$

4.16 > Trigonometry

9. Domain of the function  $f(x) = \cos^{-1}\left(\frac{5}{5 + \sin x}\right)$  is

(a)  $\bigcup_{n \in \mathbb{Z}} [2n\pi, (2n+1)\pi]$

(b)  $\bigcup_{n \in \mathbb{Z}} \left[2n\pi, (2n-1)\frac{\pi}{2}\right]$

(c)  $[n\pi, n \in \mathbb{Z}]$

(d) None of these

10. Domain of function  $f(x) = \sqrt{\sin^{-1}(2x) + \frac{\pi}{6}}$  is

(a)  $[-1, 1]$

(b)  $[-1/4, 1/2]$

(c)  $[0, 1/2]$

(d) None of these

11. Range of  $f(x) = \sin^{-1}x + \tan^{-1}x + \sec^{-1}x$  is

(a)  $\left(\frac{\pi}{4}, \frac{3\pi}{4}\right)$

(b)  $\left[\frac{\pi}{4}, \frac{3\pi}{4}\right]$

(c)  $\left\{\frac{\pi}{4}, \frac{3\pi}{4}\right\}$

(d) None of these

12. The range of  $\cos^{-1}[1 + \sin^2x]$  where  $[x]$  denotes GINT function, isfunction, is

(a)  $\{\pi/2\}$

(b)  $\{\pi/4, \pi/2\}$

(c)  $\{\pi/2, \pi/6\}$

(d) None of these

13.  $\sec^{-1}[\sec(-30^\circ)]$  is equal to

(a)  $-60^\circ$

(b)  $-30^\circ$

(c)  $30^\circ$

(d)  $150^\circ$

14.  $\sin(2 \sin^{-1}0.8)$  is equal to

(a) 0.96

(b) 0.48

(c) 0.64

(d) None of these

15. If  $\tan^{-1} \frac{\sqrt{1+x^2}-1}{x} = 4^\circ$ , then

(a)  $x = \tan 2^\circ$

(b)  $x = \tan 4^\circ$

(c)  $x = \tan(1/4)^\circ$

(d)  $x = \tan 8^\circ$

16. If  $\cos^{-1}x = \tan^{-1}x$ , then

(a)  $x^2 = \left(\frac{\sqrt{5}-1}{2}\right)$

(b)  $x^2 = \left(\frac{\sqrt{5}+1}{2}\right)$

(c)  $\sin(\cos^{-1}x) = \left(\frac{\sqrt{5}-1}{2}\right)$

(d)  $\tan(\cos^{-1}x) = \left(\frac{\sqrt{5}-1}{2}\right)$

17. If  $\frac{1}{2} \sin^{-1}\left(\frac{3 \sin 2\theta}{5+4 \cos 2\theta}\right) = \frac{\pi}{4}$ , then  $\tan \theta$  is equal to

(a)  $1/3$

(b) 3

(c) 1

(d)  $-1$

18. Number of triplets  $(x, y, z)$  satisfying  $\sin^{-1}x + \cos^{-1}y + \sin^{-1}z = 2\pi$ , is

(a) 0

(b) 2

(c) 1

(d) infinite

19. The number of solutions of equation  $2(\sin^{-1}x)^2 - 5\sin^{-1}x + 2 = 0$  is

(a) 2

(b) 1

(c) 3

(d) None of these

20. If  $\alpha$  satisfies the inequation  $x^2 - x - 2 > 0$ , then a value exists for

(a)  $\sin^{-1}\alpha$

(b)  $\cos^{-1}\alpha$

(c)  $\sec^{-1}\alpha$

(d)  $\operatorname{cosec}^{-1}\alpha$

21.  $\sin^{-1}x > \cos^{-1}x$  holds for

(a) All values of  $x$

(b)  $x \in \left(\frac{1}{\sqrt{2}}, 1\right)$

(c)  $x \in \left(\frac{1}{\sqrt{2}}, 1\right]$

(d)  $x = 0.75$

## Answer Keys

1. (b)    2. (d)    3. (a)    4. (d)    5. (a)    6. (a, b)    7. (b)    8. (d)    9. (a)    10. (b)  
 11. (c)    12. (c)    13. (c)    14. (a)    15. (d)    16. (a,c)    17. (b)    18. (c)    19. (b)  
 20. (c,d)    21. (b,c,d)

### ■ COMPOSITIONS OF TRIGONOMETRIC FUNCTIONS AND THEIR INVERSE FUNCTIONS

- (i)  $\sin(\sin^{-1} x) = x$ , for all  $x \in [-1, 1]$
- (ii)  $\cos(\cos^{-1} x) = x$ , for all  $x \in [-1, 1]$
- (iii)  $\tan(\tan^{-1} x) = x$ , for all  $x \in \mathbb{R}$
- (iv)  $\cot(\cot^{-1} x) = x$ , for all  $x \in \mathbb{R}$
- (v)  $\sec(\sec^{-1} x) = x$ , for all  $x \in (-\infty, -1] \cup [1, \infty)$
- (vi)  $\operatorname{cosec}(\operatorname{cosec}^{-1} x) = x$ , for all  $x \in (-\infty, -1] \cup [1, \infty)$

**Proof:** We know that, if  $f: A \rightarrow B$  is a bijection, then  $f^{-1}: B \rightarrow A$  exists such that  $f \circ f^{-1}(y) = f(f^{-1}(y)) = y$  for all  $y \in B$ . Clearly, all these results are direct consequence of this property.

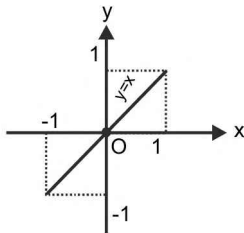

$$y = \sin(\sin^{-1}x) = \cos(\cos^{-1}x) = x$$

FIGURE 4.13

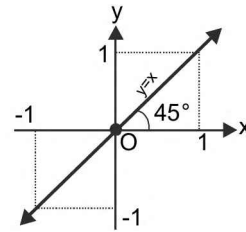

$$y = \tan(\tan^{-1}x) = \cot(\cot^{-1}x) = x \quad \forall x \in \mathbb{R}$$

FIGURE 4.14

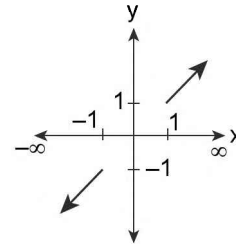

$$y = \sec(\sec^{-1}x) = \operatorname{cosec}(\operatorname{cosec}^{-1}x) = x$$

FIGURE 4.15

**Aliter:** Let  $\theta \in [-\pi/2, \pi/2]$  and  $x \in [-1, 1]$  such that  $\sin \theta = x$ . then,  $\theta = \sin^{-1} x$ .

$$\therefore x = \sin \theta = \sin(\sin^{-1} x).$$

Hence,  $\sin(\sin^{-1} x) = x$  for  $x \in [-1, 1]$ .

Similarly, we can prove other results.

**ILLUSTRATION 20:** Prove that:

- (i)  $\tan|\tan^{-1} x| = |x| \quad \forall x \in \mathbb{R}$
- (ii)  $\sin|\sin^{-1} x| = |x| \quad \forall x \in [-1, 1]$
- (iii)  $\tan(\tan^{-1} |x|) = |x| \quad \forall x \in \mathbb{R}$
- (iv)  $\cos|\cos^{-1} x| = |x| \quad \forall x \in [-1, 1]$

**Proof:**

(i) To prove :  $\tan|\tan^{-1}x| = |x|$

**Case (i):** if  $x > 0$

$$\tan^{-1} x \in [0, \pi/2) \Rightarrow |\tan^{-1} x| = \tan^{-1} x$$

$$\Rightarrow \tan|\tan^{-1} x| = \tan(\tan^{-1} x) = x = |x|$$

**Case (ii):** if  $x < 0$

$$\Rightarrow \tan^{-1} x \in \left(-\frac{\pi}{2}, 0\right) \Rightarrow |\tan^{-1} x| = -\tan^{-1} x \quad \therefore \tan|\tan^{-1} x| = \tan(-\tan^{-1} x)$$

$$= -\tan(\tan^{-1} x) = -x = |x|$$



(ii) To prove :  $\sin |\sin^{-1}x| = |x|$

**Case (i)**  $0 \leq x \leq 1 \Rightarrow \sin^{-1} x \in \left[0, \frac{\pi}{2}\right]$

$\Rightarrow |\sin^{-1} x| = \sin^{-1} x \Rightarrow \sin |\sin^{-1} x| = \sin(\sin^{-1} x) = x = |x|$

**Case (ii)**  $-1 \leq x < 0 \Rightarrow \sin^{-1} x \in \left[\frac{-\pi}{2}, 0\right)$

$\Rightarrow |\sin^{-1} x| = -\sin^{-1} x \Rightarrow \sin |\sin^{-1} x| = \sin(-\sin^{-1} x) = -\sin(\sin^{-1} x) = -x = |x|$

(iii) we know that  $\tan(\tan^{-1} t) = t \forall t \in \mathbb{R}$

$\therefore \tan(\tan^{-1} |x|) = |x| \forall x \in \mathbb{R}$

(iv) consider  $\cos |\cos^{-1} x|$

$\because \cos^{-1}(|x|) \geq 0$

$$= \cos(\cos^{-1}|x|) = \begin{cases} \cos(\cos^{-1} x) & \text{if } 0 \leq x \leq 1 \\ \cos(\cos^{-1}(-x)) & \text{if } -1 \leq x < 0 \end{cases} = \begin{cases} x & \text{if } x \in [0, 1] \\ -x & \text{if } x \in [-1, 0] \end{cases}$$

$= |x| \forall x \in [-1, 1]$

**INVERSE CIRCULAR FUNCTIONS OF THEIR CORRESPONDING TRIGONOMETRIC FUNCTIONS IN PRINCIPAL DOMAIN**

- (i)  $\sin^{-1}(\sin x) = x$ ; for all  $x \in [-\pi/2, \pi/2]$
- (ii)  $\cos^{-1}(\cos x) = x$ ; for all  $x \in [0, \pi]$
- (iii)  $\tan^{-1}(\tan x) = x$ ; for all  $x \in (-\pi/2, \pi/2)$
- (iv)  $\cot^{-1}(\cot x) = x$ ; for all  $x \in (0, \pi)$
- (v)  $\sec^{-1}(\sec x) = x$ ; for all  $x \in [0, \pi], \sim \{\pi/2\}$
- (vi)  $\operatorname{cosec}^{-1}(\operatorname{cosec} x) = x$ ; for all  $x \in [-\pi/2, \pi/2] \sim \{0\}$

**Proof:** We know that, if  $f: A \rightarrow B$  is a bijection, then  $f^{-1}: B \rightarrow A$  exists such that :  $f^{-1} \text{ of } (x) = f^{-1}(f(x)) = x$  for all  $x \in A$ . Clearly, all these results are direct consequences of this property.

**Aliter:** For any  $y \in [-\pi/2, \pi/2]$ , let  $\sin y = x$ . Then,  $y = \sin^{-1}x$

$\therefore y = \sin^{-1}(\sin y)$ .

Hence,  $\sin^{-1}(\sin x) = x$  for all  $x \in [-\pi/2, \pi/2]$ .

It should be noted that,  $\sin^{-1}(\sin x) \neq x$ , if  $x \notin [-\pi/2, \pi/2]$ .

**ILLUSTRATION 21:** Find the least integral value of  $k$  for which  $(k - 3)x^2 + 2x + k + 11\pi - 36 > \sin^{-1}(\sin 16) + \cos^{-1}(\cos 16) \forall x \in \mathbb{R}$

**SOLUTION:**  $\sin^{-1}(\sin 16) = \sin^{-1}(\sin(5\pi - 16))$

$= 5\pi - 16$  as  $5\pi - 16 \in \left(-\frac{\pi}{2}, 0\right)$ , which is subset of  $[-\pi/2, \pi/2]$

Also  $\cos^{-1}(\cos 16) = \cos^{-1}(-\cos(5\pi - 16))$

$= \pi - \cos^{-1}(\cos(16 - 5\pi))$  [ $\because \cos(\pi - \theta) = -\cos \theta$ ]

$= \pi - [16 - 5\pi] = 6\pi - 16$

$\therefore$  Given inequations become  $(k - 3)x^2 + 2x + k + 11\pi - 36 > 5\pi - 16 + 6\pi - 16$

$$\begin{aligned} &\Rightarrow (k-3)x^2 + 2x + k - 4 > 0 \quad \text{For } k = 3; 2x + k > 4 \forall x \in \mathbb{R} \\ &\Rightarrow 2x > 1 \forall x \in \mathbb{R} \quad \text{which is impossible.} \\ &\text{So let } k \geq 3 \\ &\Rightarrow (k-3)x^2 + 2x + k - 4 > 0 \forall x \in \mathbb{R}, \text{ therefore discriminant } D < 0 \\ &\Rightarrow k > 3 \text{ and } (2)^2 - 4(k-3)(k-4) < 0 \\ &\Rightarrow k > 3 \text{ and } (k-3)(k-4) > 1 \\ &\Rightarrow k > 3 \text{ and } k^2 - 7k + 11 > 0 \Rightarrow k > 3 \text{ and } k < \frac{7-\sqrt{5}}{2} \text{ or } k > \frac{7+\sqrt{5}}{2} \\ &\Rightarrow k \in \left( \frac{7+\sqrt{5}}{2}, \infty \right) \end{aligned}$$

**ILLUSTRATION 22:** Prove that  $|\tan^{-1}|\tan|x|| = |x| \forall x \in \left(-\frac{\pi}{2}, \frac{\pi}{2}\right)$

**SOLUTION:** As we know that  $\forall x \in \left(-\frac{\pi}{2}, \frac{\pi}{2}\right); \tan|x| \geq 0$

$$\begin{aligned} &\Rightarrow |\tan|x|| = \tan|x| \\ &\Rightarrow \tan^{-1}|\tan|x|| = \tan^{-1}(\tan|x|) \\ &= |x| \text{ as } \tan^{-1}(\tan\theta) = \theta \text{ for } \theta \in \left(-\frac{\pi}{2}, \frac{\pi}{2}\right) \\ &\therefore |\tan|\tan^{-1}|x|| = |x| \end{aligned}$$

**INVERSE CIRCULAR FUNCTIONS OF THEIR CORRESPONDING TRIGONOMETRIC FUNCTIONS IN COMPLETE DOMAIN**

$$1. \sin^{-1}(\sin x) = \begin{cases} -\pi - x, & \text{if } x \in [-3\pi/2, -\pi/2] \\ x, & \text{if } x \in [-\pi/2, \pi/2] \\ \pi - x, & \text{if } x \in [\pi/2, 3\pi/2] \\ -2\pi + x, & \text{if } x \in [3\pi/2, 5\pi/2] \end{cases} \quad \text{and}$$

so on as shown below:

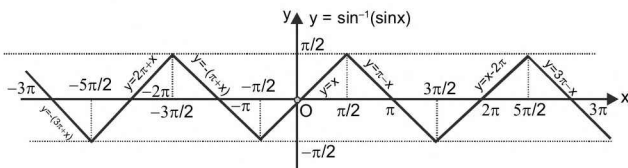

**FIGURE 4.16**

**Proof:**  $\because \sin^{-1}(\sin(2\pi + x)) = \sin^{-1}(\sin x)$   
 $\Rightarrow \sin^{-1}(\sin x)$  is periodic function with period  $2\pi$   
 Also  $\sin^{-1}(\sin(-x)) = \sin^{-1}(-\sin x) = -\sin^{-1}(\sin x) = -x$   
 For  $x \in \left[-\frac{\pi}{2}, \frac{\pi}{2}\right]$  i.e., principal domain of  $\sin x$ .  
 $\sin^{-1}(\sin x) = x \dots \dots (i)$  [ $\because \sin^{-1}(\sin x)$  for  $x \in \left[-\frac{\pi}{2}, \frac{\pi}{2}\right]$ ]  
 For  $x \in \left[\frac{\pi}{2}, \pi\right] \Rightarrow \pi - x \in \left[0, \frac{\pi}{2}\right]$   
 $\therefore \sin x = \sin(\pi - x)$   
 $\Rightarrow \sin^{-1}(\sin x) = \sin^{-1}(\sin(\pi - x)) = \pi - x \dots (ii)$   
 $\sin^{-1}(\sin x) = \sin^{-1}(-\sin(\pi + x)) = \sin^{-1}(\sin(-\pi - x))$   
 $= -\pi - x \dots (iii)$  when  $x \in \left[-\pi, -\frac{\pi}{2}\right]$

4.20 > Trigonometry

Then from (i), (ii) and (iii) we have

$$\sin^{-1}(\sin x) = \begin{cases} -\pi - x & \text{for } x \in \left[-\pi, -\frac{\pi}{2}\right] \\ x & \text{for } x \in \left[-\frac{\pi}{2}, \frac{\pi}{2}\right] \\ \pi - x & \text{for } x \in \left[\frac{\pi}{2}, \pi\right] \end{cases}$$

∴ Graph of  $\sin^{-1}(\sin x)$  for one period i.e  $2\pi$  for  $x \in [-\pi, \pi]$  is as shown below

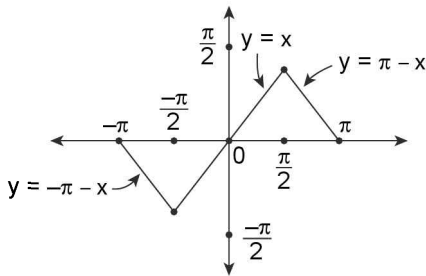

FIGURE 4.17

∴  $\sin^{-1}(\sin x)$  is periodic with period  $2\pi$ , thus the above graph would repeat for each interval of

length  $2\pi$  and hence the graph of  $\sin^{-1}(\sin x)$  on domain  $\mathbb{R}$  of  $\sin^{-1}(\sin x)$  would be as shown below.

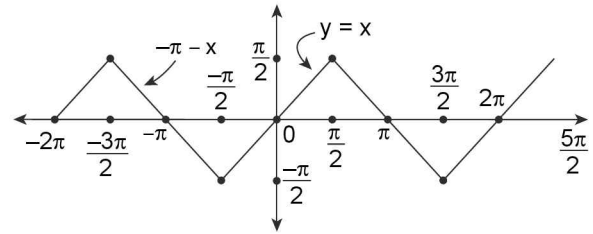

FIGURE 4.18

$$\sin^{-1}(\sin x) = \begin{cases} -\pi - x & \text{for } x \in \left[\frac{3\pi}{2}, -\frac{\pi}{2}\right] \\ x & \text{for } x \in \left[-\frac{\pi}{2}, \frac{\pi}{2}\right] \\ \pi - x & \text{for } x \in \left[\frac{\pi}{2}, \frac{3\pi}{2}\right] \\ x - 2\pi & \text{for } x \in \left[\frac{3\pi}{2}, \frac{5\pi}{2}\right] \end{cases}$$

∴ and so on

**REMARK**

$y = \sin^{-1}(\sin x)$  can be formed by tangents of  $y = \sin x$  at  $x = n\pi$  as shown below:

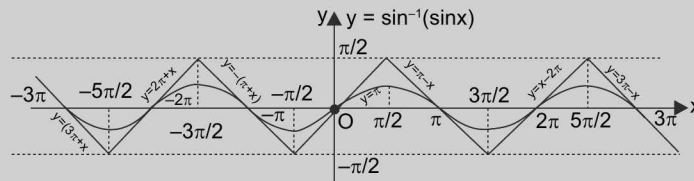

FIGURE 4.19

2.  $\cos^{-1}(\cos x) = \begin{cases} -x, & \text{if } x \in [-\pi, 0] \\ x, & \text{if } x \in [0, \pi] \\ 2\pi - x, & \text{if } x \in [\pi, 2\pi] \\ -2\pi + x, & \text{if } x \in [2\pi, 3\pi] \end{cases}$  and so on as shown below

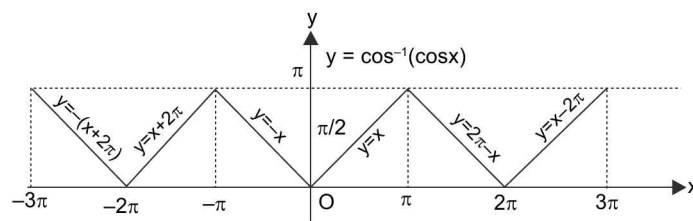

FIGURE 4.20

**Proof:**  $f(x) = \cos^{-1}(\cos x)$   
 and  $f(2\pi + x) = \cos^{-1}(\cos(2\pi + x)) = \cos^{-1}(\cos x) = f(x)$   
 $\Rightarrow f(x)$  is a periodic function with period  $2\pi$ . We know that  $\cos^{-1}(\cos x) = x$  for  $x \in [0, \pi]$   
 Also  $f(x) = \cos^{-1}(\cos x)$   
 $\Rightarrow f(-x) = \cos^{-1}(\cos(-x)) = \cos^{-1}(\cos x) = f(x)$   
 $\Rightarrow f(x)$  is an even function  
 $\Rightarrow f(x)$  is symmetric about y-axis  
 $\Rightarrow \cos^{-1}(\cos x) = -x$  for  $x \in [-\pi, 0]$  and  $\cos^{-1}(\cos x) = x$  for  $x \in [0, \pi]$   
 $\Rightarrow$  So the graph  $y = \cos^{-1}(\cos x)$  for one complete period  $2\pi$  on interval  $[-\pi, \pi]$  would be as shown below

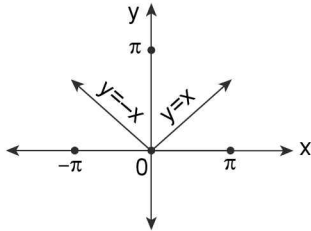

FIGURE 4.21

As  $\cos^{-1}(\cos x)$  is periodic with period  $2\pi$ , the graph of  $\cos^{-1}(\cos x)$  on the domain  $\mathbb{R}$  can be obtained by repeating the above graph for each interval of length  $2\pi$  and hence it would be as shown below:

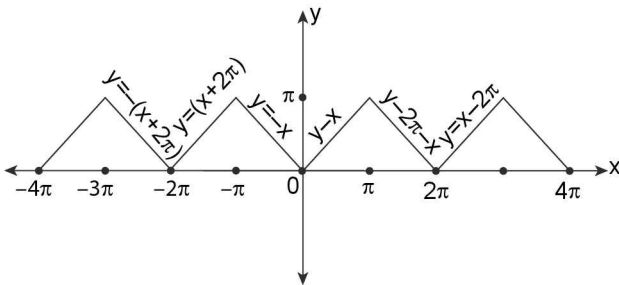

FIGURE 4.22

Thus

$$\cos^{-1}(\cos x) = \begin{cases} -x & \text{for } x \in [-\pi, 0] \\ x & \text{for } x \in [0, \pi] \\ 2\pi - x & \text{for } x \in [\pi, 2\pi] \\ x - 2\pi & \text{for } x \in [2\pi, 3\pi] \end{cases} \text{ and so on}$$

$$3. \tan^{-1}(\tan x) = \begin{cases} \pi + x, & \text{if } x \in (-3\pi/2, -\pi/2) \\ x, & \text{if } x \in (-\pi/2, \pi/2) \\ x - \pi, & \text{if } x \in (\pi/2, 3\pi/2) \\ x - 2\pi, & \text{if } x \in (3\pi/2, 5\pi/2) \end{cases} \text{ and so}$$

on as shown below:

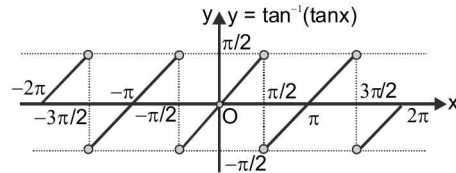

FIGURE 4.23

**Proof:** As  $y = \tan^{-1}(\tan x)$  is periodic with  $\pi$ .  
 $\therefore$  to draw this graph, we should draw the graph for one interval of length  $\pi$  and repeat for entire value of  $x$ .

$$\text{As we know; } \tan^{-1}(\tan x) = \left\{ x; -\frac{\pi}{2} < x < \frac{\pi}{2} \right\}.$$

Thus, it has been defined for  $-\frac{\pi}{2} < x < \frac{\pi}{2}$  that has length  $\pi$ .

So, its graph could be plotted as in figure.

$$4. y = \cot^{-1}(\cot x) = \begin{cases} x + 2\pi & \text{for } x \in (-2\pi, -\pi) \\ x + \pi & \text{for } x \in (-\pi, 0) \\ x & \text{for } x \in (0, \pi) \\ x - \pi & \text{for } x \in (\pi, 2\pi) \\ x - 2\pi & \text{for } x \in (2\pi, 3\pi) \end{cases}$$

The graph of  $\cot^{-1}(\cot x)$  is as shown below

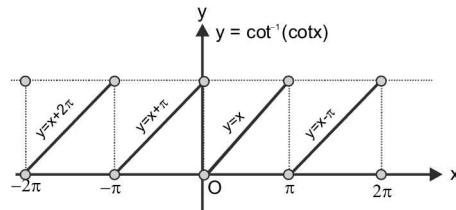

FIGURE 4.24

**Domain:**  $x \in \mathbb{R} - \{n\pi, n \in \mathbb{Z}\}$

**Range:**  $y \in (0, \pi)$

**Period:** periodic with period  $\pi$  and  $\cot^{-1}(\cot x) = x \forall x \in (0, \pi)$

4.22 ➤ Trigonometry

$$5. y = \sec^{-1}(\sec x) = \begin{cases} -x & \text{for } x \in [-\pi, 0] \sim \left\{-\frac{\pi}{2}\right\} \\ x & \text{for } x \in [0, \pi] \sim \left\{\frac{\pi}{2}\right\} \\ 2\pi - x & \text{for } x \in [\pi, 2\pi] \sim \left\{\frac{3\pi}{2}\right\} \end{cases}$$

The graph of  $y = \sec^{-1}(\sec x)$  is as shown below

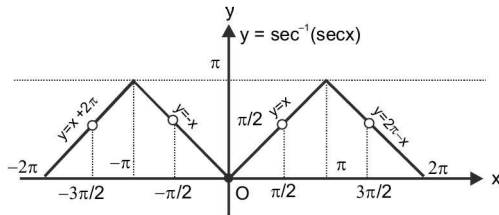

FIGURE 4.25

**Domain:**  $x \in \mathbb{R} - \left\{(2n+1)\frac{\pi}{2}, n \in \mathbb{Z}\right\}$

**Range:**  $y \in [0, \pi/2) \cup (\pi/2, \pi]$

**Period:** Periodic with period  $2\pi$  and  $\sec^{-1}(\sec x) = x \forall x \in [0, \pi/2) \cup (\pi/2, \pi]$

**Proof:** Left for reader as an exercise

6.  $y = \operatorname{cosec}^{-1}(\operatorname{cosec} x)$

$$= \begin{cases} -(\pi + x) & \text{for } x \in \left[-\frac{3\pi}{2}, -\frac{\pi}{2}\right] \sim \{-\pi\} \\ x & \text{for } x \in \left[-\frac{\pi}{2}, \frac{\pi}{2}\right] \sim \{0\} \\ \pi - x & \text{for } x \in \left[\frac{\pi}{2}, \frac{3\pi}{2}\right] \sim \{\pi\} \end{cases}$$

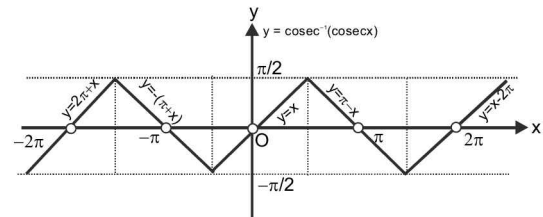

FIGURE 4.26

**Domain:**  $x \in \mathbb{R} \sim \{n\pi, n \in \mathbb{Z}\}$

**Range:**  $y \in [-\pi/2, \pi/2] \sim \{0\}$

**Period:** Periodic with period  $2\pi$  and  $\operatorname{cosec}^{-1}(\operatorname{cosec} x) = x$  for  $x \in [-\pi/2, \pi/2] \sim \{0\}$

**Proof:** Left for reader as an exercise

**ILLUSTRATION 23:** Evaluate:

- |   |   |   |
|---|---|---|
| (i) $\sin^{-1}\left(\sin \frac{\pi}{6}\right)$  | (ii) $\cos^{-1}\left(\cos \frac{\pi}{3}\right)$ | (iii) $\tan^{-1}\left(\tan \frac{3\pi}{4}\right)$             |
| (iv) $\sin\left(\sin^{-1} \frac{\pi}{6}\right)$ | (v) $\cos\left(\cos^{-1} \frac{\pi}{4}\right)$  | (vi) $\tan\left(\tan^{-1} \frac{2\pi}{3}\right)$              |
| (vii) $\sin^{-1}(\sin 11.56)$                   | (viii) $\sin(\sin^{-1}(10.5))$                  | (ix) $\cos(\cos^{-1}6)$                                       |
| (x) $\cos^{-1}(\cos 6)$                         | (xi) $\tan(\tan^{-1}(5.2))$                     | (xiii) $\sin\left(\sin^{-1}\left(\frac{\pi}{2}\right)\right)$ |

**SOLUTION:** (i)  $\sin^{-1}\left(\sin \frac{\pi}{6}\right) = \frac{\pi}{6}; \because \sin^{-1}(\sin x) = x \forall x \in \left[-\frac{\pi}{2}, \frac{\pi}{2}\right]$

(ii)  $\cos\left(\cos^{-1} \frac{\pi}{3}\right) = \frac{\pi}{3}; \because \cos^{-1}(\cos x) = x \forall x \in [0, \pi]$

(iii)  $\tan^{-1}\left(\tan \frac{3\pi}{4}\right) = \tan^{-1}\left[\tan\left(\pi - \frac{\pi}{4}\right)\right] = \tan^{-1}\left(-\tan \frac{\pi}{4}\right) = \tan^{-1}\left[\tan\left(-\frac{\pi}{4}\right)\right]$   
 $= -\frac{\pi}{4}; \because \tan^{-1}(\tan x) = x \text{ for } x \in \left(-\frac{\pi}{2}, \frac{\pi}{2}\right)$

or  $\because \tan^{-1}(\tan x) = x - \pi \forall x \in \left(\frac{\pi}{2}, \frac{3\pi}{2}\right) \therefore \tan^{-1}\left(\tan \frac{3\pi}{4}\right) = \left(\frac{3\pi}{4} - \pi\right) = -\frac{\pi}{4}$

$$(iv) \sin\left(\sin^{-1}\frac{\pi}{6}\right) = \frac{\pi}{6}; \because \sin(\sin^{-1}x) = x \text{ for } x \in [-1, 1] \text{ and } \frac{\pi}{6} \in (0, 1)$$

$$(v) \cos\left(\cos^{-1}\frac{\pi}{4}\right) = \frac{\pi}{4}; \because \cos(\cos^{-1}x) = x \text{ for } x \in [-1, 1] \text{ \& } \frac{\pi}{4} \in (0, 1)$$

$$(vi) \tan\left(\tan^{-1}\frac{2\pi}{3}\right) = \frac{2\pi}{3}; \because \tan(\tan^{-1}x) = x \text{ for } x \in (-\infty, \infty)$$

$$(vii) \sin^{-1}(\sin 11.56); \because 11.56 \in \left[\frac{7\pi}{2}, 4\pi\right] \text{ where } \sin^{-1}(\sin x) = x - 4\pi$$

$$\therefore \sin^{-1}(\sin 11.56) = (11.56 - 4\pi)$$

$$(viii) \sin(\sin^{-1}(10.5)) \sin(\sin^{-1}x) \text{ is defined only for } x \in [-1, 1]$$

$$\therefore \sin(\sin^{-1}(10.5)) \text{ is not defined.}$$

$$(ix) \cos(\cos^{-1}6) = \text{not defined as } \cos(\cos^{-1}x) \text{ is defined only for } x \in [-1, 1].$$

$$(x) \cos^{-1}(\cos 6) = \cos^{-1}[\cos(2\pi - 6)]$$

$$\because \cos^{-1}(\cos x) = 2\pi - x \quad \forall x \in [\pi, 2\pi] \text{ and } 6 \in [\pi, 2\pi]$$

$$\therefore \cos^{-1}(\cos 6) = 2\pi - 6$$

$$(xi) \tan(\tan^{-1}5.2) = 5.2; \because \tan(\tan^{-1}x) = x \text{ for } x \in \mathbb{R}$$

$$(xii) \sin\left(\sin^{-1}\left(\frac{\pi}{2}\right)\right) \text{ is not defined as } \sin(\sin^{-1}x) \text{ is defined only for } x \in [-1, 1].$$

**ILLUSTRATION 24:** Evaluate:

$$(i) \cos^{-1}\cos 10 - \sin^{-1}\sin 10$$

$$(ii) \sin^{-1}\left(\sin\frac{2\pi}{3}\right) + \cos^{-1}\left(\cos\frac{2\pi}{3}\right)$$

$$(iii) 2\sin^{-1}\left(\sin\frac{2\pi}{3}\right) + \sin\left(\sin^{-1}\frac{\pi}{6}\right)$$

**SOLUTION:** (i)  $\cos^{-1}\cos 10 - \sin^{-1}\sin 10$

$$3\pi < 10 < \frac{7\pi}{2}; \text{ where } \cos^{-1}\cos x = 4\pi - x \text{ and } \sin^{-1}(\sin x) = x - 3\pi$$

$$\therefore \cos^{-1}(\cos 10) = 4\pi - 10.$$

$$\text{Now, } \sin^{-1}(\sin 10) = (3\pi - 10)$$

$$\text{Thus } \cos^{-1}(\cos 10) - \sin^{-1}(\sin 10) = (4\pi - 10) - (3\pi - 10) = \pi.$$

$$(ii) \sin^{-1}\left(\sin\frac{2\pi}{3}\right) + \cos^{-1}\left(\cos\frac{2\pi}{3}\right) = \sin^{-1}\left(\sin\left(\pi - \frac{\pi}{3}\right)\right) + \frac{2\pi}{3} \quad [\because \cos^{-1}(\cos x) = x \text{ for } x \in [0, \pi]]$$

$$= \sin^{-1}\left(\sin\frac{\pi}{3}\right) + \frac{2\pi}{3} = \frac{\pi}{3} + \frac{2\pi}{3} = \pi \quad [\because \sin^{-1}(\sin x) = x \text{ for } x \in \left[-\frac{\pi}{2}, \frac{\pi}{2}\right]]$$

$$(iii) 2\sin^{-1}\left(\sin\frac{2\pi}{3}\right) + \sin\left(\sin^{-1}\frac{\pi}{6}\right) = 2\sin^{-1}\left[\sin\left(\pi - \frac{\pi}{3}\right)\right] + \frac{\pi}{6}$$

$$\left[\because \sin(\sin^{-1}x) = x \text{ for } x \in [-1, 1] \text{ and } \frac{\pi}{6} \in (0, 1)\right] = 2\sin^{-1}\left[\sin\frac{\pi}{3}\right] + \frac{\pi}{6} = \frac{2\pi}{3} + \frac{\pi}{6} = \frac{5\pi}{6}.$$

**ILLUSTRATION 25:** Find the value of the expression  $\sin^{-1}\left(\sin\frac{22}{7}\pi\right) + \cos^{-1}\left(\cos\frac{5\pi}{3}\right) + \tan^{-1}\left(\tan\frac{5\pi}{7}\right) + \sin^{-1}(\cos 2)$

**SOLUTION:** Clearly  $\sin^{-1}\left(\sin\frac{22\pi}{7}\right) = 3\pi - \frac{22\pi}{7} = -\frac{\pi}{7}$

$$\therefore \sin^{-1}(\sin x) = 3\pi - x \forall x \in \left[\frac{5\pi}{2}, \frac{7\pi}{2}\right] \text{ and } \pi < \frac{22}{7}\pi < 7\pi/2$$

$$\text{Now, } \cos^{-1}\left(\cos\frac{5\pi}{3}\right) = 2\pi - \frac{5\pi}{3} = \frac{\pi}{3}$$

$$\therefore \cos^{-1}(\cos x) = 2\pi - x \forall x \in [\pi, 2\pi] \text{ and } \frac{5\pi}{3} \in [\pi, 2\pi]$$

$$\text{Also, } \tan^{-1}\left(\tan\frac{5\pi}{7}\right) = -\pi + \frac{5\pi}{7} = -\frac{2\pi}{7}$$

$$\therefore \tan^{-1}(\tan x) = -\pi + x \forall x \in \left(\frac{\pi}{2}, \frac{3\pi}{2}\right) \text{ and } \frac{\pi}{2} < \frac{5\pi}{7} < \pi$$

$$\text{Also, } \sin^{-1}(\cos 2) = \sin^{-1}\left[\sin\left(\frac{\pi}{2} - 2\right)\right] = \frac{\pi}{2} - 2$$

$$\therefore \frac{\pi}{2} - 2 \approx 1.57 - 2 = -0.43 \in \left[\frac{-\pi}{2}, 0\right]$$

$$\begin{aligned} \therefore \sin^{-1}\left(\sin\frac{22}{7}\pi\right) + \cos^{-1}\left(\cos\frac{5\pi}{3}\right) + \tan^{-1}\left(\tan\frac{5\pi}{7}\right) + \sin^{-1}(\cos 2) &= \\ &= \frac{-\pi}{7} + \frac{\pi}{3} - \frac{2\pi}{7} + \frac{\pi}{2} - 2 = -\frac{3\pi}{7} + \frac{\pi}{3} + \frac{\pi}{2} - 2 = \frac{17\pi}{42} - 2 \end{aligned}$$

**ILLUSTRATION 26:** If  $\sin^{-1}(\sin 5) > x^2 - 4x$ , then find all possible integer values of  $x$ .

**SOLUTION:** Since  $\frac{3\pi}{2} < 5 < 2\pi$ ; therefore  $\sin^{-1}(\sin 5) = 5 - 2\pi$

$$\therefore \sin^{-1}(\sin x) = -2\pi + x \forall x \in \left[\frac{3\pi}{2}, \frac{5\pi}{2}\right] \therefore \text{A.T.Q; } 5 - 2\pi > x^2 - 4x$$

$$\Rightarrow x^2 - 4x + 2\pi - 5 < 0$$

The roots of quadratic are  $\alpha = 2 - \sqrt{9 - 2\pi}$ ,  $\beta = 2 + \sqrt{9 - 2\pi}$

$$\therefore x^2 - 4x + 2\pi - 5 < 0 \Rightarrow (x - \alpha)(x - \beta) < 0 \Rightarrow x \in (\alpha, \beta)$$

$$\Rightarrow x \in \left(2 - \sqrt{9 - 2\pi}, 2 + \sqrt{9 - 2\pi}\right)$$

$$9 - 2\pi \approx 9 - 2(3.14) = 9 - 6.28 = 2.72$$

$$\therefore \sqrt{9 - 2\pi} \approx \sqrt{2.72} \approx 1.65$$

$$\therefore x \in (2 - 1.65, 2 + 1.65)$$

$$x \in (0.35, 3.65)$$

$\therefore$  Integer values of  $x$  lying in the solution set are 1, 2, 3.

**ILLUSTRATION 27:** Evaluate:  $\sin [\sin^{-1}1/2 + \cos^{-1}1/3]$

**SOLUTION:**  $\sin [\sin^{-1}1/2 + \cos^{-1}1/3] = \sin(\sin^{-1}1/2) \cos(\cos^{-1}1/3) + \cos(\sin^{-1}1/2) \sin(\cos^{-1}1/3)$   
 $= (1/2)(1/3) + \cos(\sin^{-1}1/2) \sin(\cos^{-1}1/3)$

$$\left[ \begin{array}{l} \because \sin(\sin^{-1}x) = x \text{ for } x \in [-1, 1] \\ \cos(\cos^{-1}x) = x \text{ for } x \in [-1, 1] \\ \therefore \sin^{-1}\frac{1}{2} = \theta \in \left(0, \frac{\pi}{2}\right) \\ \text{and } \cos^{-1}\frac{1}{3} = \phi \in (0, \pi/2) \\ \Rightarrow \cos\left(\sin^{-1}\frac{1}{2}\right) = \cos\theta = \sqrt{1 - \sin^2\theta} = \sqrt{1 - \frac{1}{4}} = \frac{\sqrt{3}}{2} \\ \text{and } \sin\left(\cos^{-1}\frac{1}{3}\right) = \sin\phi = \sqrt{1 - \cos^2\phi} = \sqrt{1 - \frac{1}{9}} = \frac{2\sqrt{2}}{3} \end{array} \right]$$

$$= \frac{1}{6} + \frac{\sqrt{3}}{2} \cdot \frac{2\sqrt{2}}{3} = \frac{1}{6} + \frac{\sqrt{6}}{3} = \frac{1 + 2\sqrt{6}}{6}$$

**ILLUSTRATION 28:** For every real value of  $\theta$ , there is an integer  $n$ , such that

$$\theta \in \left[2n\pi - \frac{\pi}{2}, 2n\pi + \frac{\pi}{2}\right] \cup \left[(2n+1)\pi - \frac{\pi}{2}, (2n+1)\pi + \frac{\pi}{2}\right]. \text{ Now two cases arise.}$$

- (i) If  $\theta \in \left[2n\pi - \frac{\pi}{2}, 2n\pi + \frac{\pi}{2}\right]$  for some integer  $n$ , then  $\sin^{-1}(\sin\theta) = \theta - 2n\pi$  and  
(ii) if  $\theta \in \left[(2n+1)\pi - \frac{\pi}{2}, (2n+1)\pi + \frac{\pi}{2}\right]$  for some integer  $n$ , then  $\sin^{-1}(\sin\theta) = (2n+1)\pi - \theta$ .

**Based on above information answer the following questions:**

- If  $k_1 = \sin^{-1}(\sin 16)$ , then value of  $k_1$  is  
 (a)  $16 - 5\pi$  (b)  $4\pi - 12$   
 (c)  $5\pi - 16$  (d)  $12 - 4\pi$
- If  $k_2 = \sin^{-1}(\sin(k_1 - 5\pi + 23))$ , then the value of  $k_2$  is  
 (a)  $7 - 2\pi$  (b)  $2\pi - 7$   
 (c)  $3\pi - 9$  (d)  $9 - 3\pi$
- Value of  $\sin^{-1}(\sin(k_2 + 4\pi + 2)) =$   
 (a)  $7 - 2\pi$  (b)  $2\pi - 7$   
 (c)  $3\pi - 9$  (d)  $9 - 3\pi$

**SOLUTION:** 1.  $k_1 = \sin^{-1}(\sin 16) \because 5\pi - \frac{\pi}{2} < 16 < 5\pi + \frac{\pi}{2}$

i.e.,  $[2(2)+1]\pi - \frac{\pi}{2} < 16 < [2(2)+1]\pi + \frac{\pi}{2}$ ; thus  $n = 2$

$\therefore \sin^{-1}(\sin 16) = [2(2) + 1]\pi - 16 = 5\pi - 16 \quad \therefore \text{Ans (c)}$



$$2. k_2 = \sin^{-1}(\sin(k_1 - 5\pi + 23)) = \sin^{-1}[\sin(5\pi - 16 - 5\pi + 23)]$$

$$= \sin^{-1}[\sin(7)] = 7 - 2\pi$$

$$\left\{ \because \left( 2\pi - \frac{\pi}{2} \right) < 7 < \left( 2\pi + \frac{\pi}{2} \right) \right\}$$

$\therefore$  **Ans (a)**

$$3. \sin^{-1}(\sin(k_2 + 4\pi + 2)) = \sin^{-1}(\sin(7 - 2\pi + 4\pi + 2))$$

$$= \sin^{-1}[\sin(2\pi + 9)]$$

$$\left\{ \because 5\pi - \frac{\pi}{2} < 2\pi + 9 < 5\pi + \frac{\pi}{2} \right\}$$

$$\Rightarrow \sin^{-1}[\sin(2\pi + 9)] = 5\pi - (2\pi + 9) = 3\pi - 9$$

**Aliter**  $\sin^{-1}[\sin(2\pi + 9)] = \sin^{-1}[\sin 9]$

$$3\pi - \frac{\pi}{2} < 9 < 3\pi + \frac{\pi}{2}$$

$\therefore \sin^{-1}[\sin 9] = 3\pi - 9 \therefore$  **Ans. (c)**

## TEXTUAL EXERCISE-2 (SUBJECTIVE)

1. Evaluate the following expressions:

- |                              |                              |
|------------------------------|------------------------------|
| (a) $\sin^{-1}(\sin \pi/3)$  | (b) $\cos^{-1}(\cos \pi/6)$  |
| (c) $\tan^{-1}(\tan 2\pi/3)$ | (d) $\sin(\sin^{-1}\pi/3)$   |
| (e) $\cos(\cos^{-1} \pi/6)$  | (f) $\tan(\tan^{-1} 2\pi/3)$ |
| (g) $\sin^{-1}(\sin 10)$     | (h) $\sin(\sin^{-1} 10)$     |
| (i) $\cos(\cos^{-1} 5)$      | (j) $\cos^{-1}(\cos 5)$      |
| (k) $\tan(\tan^{-1}(-5))$    | (l) $\tan^{-1}(\tan 5)$      |

2. (a) Find the value of  $\cos^{-1}\left(\cos \frac{7\pi}{6}\right)$ .
- (b) Find the value of  $\sin\left[\frac{\pi}{2} - \sin^{-1}\left(-\frac{\sqrt{3}}{2}\right)\right]$ .
- (c) Find the value of  $\sin\left[\arccos\left(-\frac{1}{2}\right)\right]$ .
- (d) Find the value of  $\sin\left[\tan^{-1}(-\sqrt{3}) + \cos^{-1}\left(-\frac{\sqrt{3}}{2}\right)\right]$ .
3. If  $y = \sin^{-1}(\sin 8) - \tan^{-1}(\tan 10) + \cos^{-1}(\cos 12) - \sec^{-1}(\sec 9) + \cot^{-1}(\cot 6) - \operatorname{cosec}^{-1}(\operatorname{cosec} 7)$ . If  $y$  simplifies to  $a\pi + b$ , then find  $(a-b)$ .
4. Show that  $\sin^{-1}\left(\sin \frac{33\pi}{7}\right) + \cos^{-1}\left(\cos \frac{46\pi}{7}\right) + \tan^{-1}\left(-\tan \frac{13\pi}{8}\right) + \cot^{-1}\left(\cot\left(-\frac{19\pi}{8}\right)\right) = \frac{13\pi}{7}$

5. Find the simplest value of  $f(x) = \arccos x + \arccos$

$$\left(\frac{x}{2} + \frac{1}{2}\sqrt{3-3x^2}\right); x \in \left(\frac{1}{2}, 1\right)$$

6. If  $\alpha = 2 \tan^{-1}\left(\frac{1+x}{1-x}\right)$  and  $\beta = \sin^{-1}\left(\frac{1-x^2}{1+x^2}\right)$  for

$0 < x < 1$ , then prove that  $\alpha + \beta = \pi$ , what is the value for  $x > 1$ ?

7. If  $x \in \left[-1, \frac{-1}{2}\right]$ , then express the function  $f(x) = \sin^{-1}$

$(3x - 4x^3) + \cos^{-1}(4x^3 - 3x)$  in the form of  $a\cos^{-1}x + b\pi$ , where  $a$  and  $b$  are rational numbers.

8. If the total area enclosed between the curves  $f(x) = \cos^{-1}(\sin x)$  and  $\sin^{-1}(\cos x)$  on the interval  $[-7\pi, 7\pi]$  is  $A$ , find the value of  $49A$ .

9. Solve for  $x$ :  $\sin^{-1}\left(\sin\left(\frac{2x^2+4}{1+x^2}\right)\right) < \pi - 3$

10. Solve the following equations:

(i)  $5\tan^{-1}x + 3 \cot^{-1}x = 2\pi$

(ii)  $4\sin^{-1}x = \pi - \cos^{-1}x$

## Answer Keys

1. (a)  $\pi/3$  (b)  $\pi/6$  (c)  $-\pi/3$  (d) not defined (e)  $\pi/6$  (f)  $2\pi/3$  (g)  $3\pi - 10$   
 (h) not defined (i) not defined (j)  $2\pi - 5$  (k)  $-5$  (l)  $(5 - 2\pi)$
2. (a)  $\frac{5\pi}{6}$  (b)  $\frac{1}{2}$  (c)  $\frac{\sqrt{3}}{2}$  (d) 1      3. 53      5.  $\pi/3$
6.  $-\pi$       7.  $a = 6, b = -9/2$
8. 343 Square unit      9.  $x \in (-1, 1)$       10. (i)  $x = 1,$       (ii)  $x = 1/2$

## TEXTUAL EXERCISE-2 (OBJECTIVE)

1. Indicate the relation which is true.  
 (a)  $\tan |\tan^{-1} x| = |x| \forall x \in \mathbb{R}$   
 (b)  $\cot |\cot^{-1} x| = x \forall x \in \mathbb{R}$   
 (c)  $\tan^{-1} |\tan x| = |x| \forall x \in \mathbb{R} \sim \{(2k+1)\pi/2\}$   
 (d)  $\sin |\sin^{-1} x| = |x| \forall x \in [-1, 1]$
2. The principal value of  $\sin^{-1}\left(\sin \frac{2\pi}{3}\right)$  is  
 (a)  $-\frac{2\pi}{3}$  (b)  $\frac{2\pi}{3}$   
 (c)  $\frac{4\pi}{3}$  (d) None of these
3. The values of  $\cos\left[\frac{1}{2}\cos^{-1}\left(\cos\left(-\frac{14\pi}{5}\right)\right)\right]$  is  
 (a)  $\cos\left(-\frac{7\pi}{5}\right)$  (b)  $\sin\left(\frac{\pi}{10}\right)$   
 (c)  $\cos\left(\frac{2\pi}{5}\right)$  (d)  $-\cos\left(\frac{3\pi}{5}\right)$
4.  $\cos\left(\cos^{-1}\left(\frac{7}{25}\right)\right)$  is equal to  
 (a)  $\frac{25}{24}$  (b)  $\frac{25}{7}$   
 (c)  $\frac{24}{25}$  (d) None of these
5. The principal value of  $\sin^{-1}\left(\sin \frac{5\pi}{3}\right)$  is  
 (a)  $\frac{5\pi}{3}$  (b)  $-\frac{5\pi}{3}$   
 (c)  $-\frac{\pi}{3}$  (d)  $\frac{4\pi}{3}$
6. The value of  $\cos^{-1}(\cos 7)$  is  
 (a)  $< \pi/2$  (b)  $< 1$   
 (c)  $> 0$  (d)  $> \pi$
7. If  $\cos(2 \sin^{-1} x) = \frac{1}{9}$ , then  $x$  is equal to  
 (a)  $\pm \frac{1}{3}$  (b)  $\pm \frac{3}{2}$   
 (c)  $\pm -$  (d) None of these
8. The Principal value of  $\cos^{-1}(\cos 8) - \sin^{-1} \sin 8$  is  
 (a)  $\pi$  (b)  $\pi + 16$   
 (c)  $16 - 5\pi$  (d) None of these
9. If  $\sin^{-1}(\sin x) + \cos^{-1}(\cos y) + \sec^{-1}(\sec z) = \frac{5\pi}{2}$  then the value of  $\sin x + \cos y + \sec z$  is  
 (a) 1 (b)  $-1$   
 (c) 3 (d) None of these
10. If  $\cos^{-1}[\sin(\sin^{-1}(\sin x))] = 0$ , then the value of  $\tan \frac{x}{2}$  is ( $x \in [0, 2\pi]$ )  
 (a) 1 (b)  $-1$   
 (c)  $\infty$  (d) None of these
11. The value of  $\sec^{-1}\left[\operatorname{cosec}\left\{\cot\left(\cot^{-1}\left(\frac{3\pi}{4}\right)\right)\right\}\right]$  is  
 (a)  $\frac{3\pi}{4}$  (b)  $\frac{\pi}{2}$   
 (c)  $\frac{\pi}{4}$  (d) None of these
12. The value of  $\left|\sin\left(\tan^{-1}\left(\tan \frac{3\pi}{4}\right)\right)\right|$  equals; where  
 [.] is gint function and || is modulus function  
 (a) 1 (b)  $-1$   
 (c) 0 (d) None of these

13. The value  $\tan\left(\frac{1}{2}\cos^{-1}\frac{\sqrt{5}}{3}\right)$  is
- (a)  $\frac{\sqrt{5}-3}{2}$  (b)  $\frac{3-\sqrt{5}}{2}$   
 (c)  $\frac{3+\sqrt{5}}{2}$  (d)  $\frac{-3-\sqrt{5}}{2}$
14. Let  $\theta = \tan^{-1}\left(\tan\frac{5\pi}{4}\right)$  and  $\phi = \tan^{-1}\left(-\tan\frac{2\pi}{3}\right)$ , then
- (a)  $\theta > \phi$  (b)  $4\theta - 3\phi = 0$   
 (c)  $\theta + \phi = \frac{7\pi}{12}$  (d) None of these
15. The value of  $\sin^{-1}[\cos\{\cos^{-1}(\cos x) + \sin^{-1}(\sin x)\}]$ ; where  $x \in \left(\frac{\pi}{2}, \pi\right)$  is
- (a)  $\frac{\pi}{2}$  (b)  $\frac{\pi}{4}$   
 (c)  $\frac{-\pi}{4}$  (d)  $\frac{-\pi}{2}$

16. If  $f(x) = \cos^{-1}x + \cos^{-1}\left\{\frac{x}{2} + \frac{1}{2}\sqrt{3-3x^2}\right\}$ , then
- (i) The value of  $f\left(\frac{2}{3}\right)$  is
- (a)  $\frac{\pi}{6}$  (b)  $\frac{\pi}{3}$   
 (c)  $\frac{-\pi}{3}$  (d) None of these
- (ii) The value of  $f\left(\frac{1}{3}\right)$  is
- (a)  $2\cos^{-1}\left(\frac{1}{3}\right) - \frac{\pi}{3}$   
 (b)  $\frac{\pi}{3}$   
 (c)  $\frac{-\pi}{3}$   
 (d) None of these

## Answer Keys

1. (a, b, d) 2. (d) 3. (b, c, d) 4. (d) 5. (c) 6. (a, b, c) 7. (c) 8. (c) 9. (b) 10. (a)  
 11. (c) 12. (c) 13. (b) 14. (b, c) 15. (d) 16. (i) (b) (ii) (a)

### INVERSE TRIGONOMETRIC FUNCTIONS OF NEGATIVE INPUTS

- (i)  $\sin^{-1}(-x) = -\sin^{-1}(x)$ , for all  $x \in [-1, 1]$   
 (ii)  $\cos^{-1}(-x) = \pi - \cos^{-1}(x)$ , for all  $x \in [-1, 1]$   
 (iii)  $\tan^{-1}(-x) = -\tan^{-1}x$ , for all  $x \in R$   
 (iv)  $\operatorname{cosec}^{-1}(-x) = -\operatorname{cosec}^{-1}x$ , for all  $x \in (-\infty, -1] \cup [1, \infty)$   
 (v)  $\sec^{-1}(-x) = \pi - \sec^{-1}x$ , for all  $x \in (-\infty, -1] \cup [1, \infty)$   
 (vi)  $\cot^{-1}(-x) = \pi - \cot^{-1}x$ , for all  $x \in R$

**Proof:**

- (i) Clearly,  $-x \in [-1, 1]$  for all  $x \in [-1, 1]$   
 Let  $\sin^{-1}(-x) = \theta$  ..... (i)  
 then,  $-x = \sin \theta \Rightarrow x = -\sin \theta$   
 $\Rightarrow x = \sin(-\theta)$   
 $\{\because x \in [-1, 1] \text{ and } -\theta \in [-\pi/2, \pi/2] \text{ for all } \theta \in [-\pi/2, \pi/2], \text{ therefore } \sin^{-1}x = \sin^{-1}(\sin(-\theta)) = -\theta$   
 $\Rightarrow \theta = -\sin^{-1}x$  ..... (ii)  
 from (i) and (ii), we get  $\sin^{-1}(-x) = -\sin^{-1}(x)$

- (ii) Clearly,  $-x \in [-1, 1]$  for all  $x \in [-1, 1]$   
 Let  $\cos^{-1}(-x) = \theta$  ..... (i)  
 then,  $-x = \cos \theta$   
 $\Rightarrow x = -\cos \theta \Rightarrow x = \cos(\pi - \theta)$   
 $[\because x \in (-1, 1) \text{ and } \pi - \theta \in [0, \pi] \text{ for all } \theta \in [0, \pi]$   
 $\Rightarrow \cos^{-1}x = \cos^{-1}(\cos(\pi - \theta))$   
 $\Rightarrow \cos^{-1}x = \pi - \theta$  ..... (ii)  
 $\Rightarrow \theta = \pi - \cos^{-1}x$   
 from (i) and (ii), we get  $\cos^{-1}(-x) = \pi - \cos^{-1}x$   
 Similarly, we can prove other results.

### INVERSE TRIGONOMETRIC FUNCTIONS OF RECIPROCAL INPUTS

- (i)  $\sin^{-1}(1/x) = \operatorname{cosec}^{-1}x$ , for all  $x \in (-\infty, -1] \cup [1, \infty)$   
 (ii)  $\cos^{-1}(1/x) = \sec^{-1}x$ , for all  $x \in (-\infty, -1] \cup [1, \infty)$   
 (iii)  $\tan^{-1}(1/x) = \begin{cases} \cot^{-1}x, & \text{for } x > 0 \\ -\pi + \cot^{-1}x, & \text{for } x < 0 \end{cases}$

**Proof:**

(i) Let,  $\operatorname{cosec}^{-1} x = \theta$  ..... (i)

Then,  $x = \operatorname{cosec} \theta \Rightarrow 1/x = \sin \theta$

$$\{\because x \in (-\infty, -1] \cup [1, \infty) \Rightarrow \frac{1}{x} \in [-1, 1] - \{0\}$$

$$\operatorname{cosec}^{-1} x = \theta \Rightarrow \theta \in [-\pi/2, \pi/2] - \{0\}$$

$$\Rightarrow \theta = \sin^{-1}(1/x) \quad \dots (ii)$$

from (i) and (ii), we get  $\sin^{-1}(1/x) = \operatorname{cosec}^{-1} x$ .

(ii) Let,  $\sec^{-1} x = \theta$  ..... (i)

then,  $x \in (-\infty, -1] \cup [1, \infty)$  and  $\theta \in [0, \pi] - \{\pi/2\}$

Now,  $\sec^{-1} x = \theta$

$$\Rightarrow x = \sec \theta \Rightarrow 1/x = \cos \theta \Rightarrow \theta = \cos^{-1}(1/x)$$

$$\{\because 1/x \in [-1, 1] \sim \{0\} \text{ and } \theta \in [0, \pi] \sim [\pi, 2\pi]\}$$

### INTER CONVERSION OF INVERSE TRIGONOMETRIC FUNCTIONS

(a)  $\sin^{-1} x = \begin{cases} \cos^{-1} \sqrt{1-x^2} & \text{if } 0 \leq x \leq 1; \\ -\cos^{-1} \sqrt{1-x^2} & \text{if } -1 \leq x \leq 0 \end{cases}$  .....(i)

$$= \tan^{-1} \left( \frac{x}{\sqrt{1-x^2}} \right) \text{ if } \forall x \in (-1, 1) \quad \dots(ii)$$

$$= \begin{cases} \cot^{-1} \frac{\sqrt{1-x^2}}{x} & \text{if } 0 < x \leq 1; \\ -\pi + \cot^{-1} \frac{\sqrt{1-x^2}}{x} & \text{if } -1 \leq x < 0 \end{cases} \quad \dots(iii)$$

$$= \begin{cases} \sec^{-1} \left( \frac{1}{\sqrt{1-x^2}} \right) & \text{if } x \in [0, 1) \\ -\sec^{-1} \left( \frac{1}{\sqrt{1-x^2}} \right) & \text{if } x \in (-1, 0] \end{cases} \quad \dots(iv)$$

$$= \operatorname{cosec}^{-1} \left( \frac{1}{x} \right) \text{ if } x \in [-1, 1] \sim \{0\} \quad \dots(v)$$

**Proof:**
**(a) Ist Part**

For  $0 \leq x \leq 1$ ; Let  $\sin^{-1} x = \theta \Rightarrow \theta \in [0, \pi/2]$

Now  $x = \sin \theta$ , therefore  $\cos \theta = \pm \sqrt{1 - \sin^2 \theta}$

$$\because \theta \in \left[ 0, \frac{\pi}{2} \right] \Rightarrow \cos \theta \text{ is positive}$$

$$\Rightarrow \cos \theta = \sqrt{1 - \sin^2 \theta} = \sqrt{1 - x^2}$$

$$\Rightarrow \cos^{-1}(\cos \theta) = \theta = \cos^{-1} \sqrt{1 - x^2}$$

as  $\theta \in [0, \pi/2] \subset [0, \pi]$

$$\therefore \sin^{-1} x = \cos^{-1} \sqrt{1 - x^2}$$

 For  $-1 \leq x \leq 0$ 

$$\text{Let } \sin^{-1} x = \theta \Rightarrow \theta \in \left[ -\frac{\pi}{2}, 0 \right] \text{ and } x = \sin \theta$$

$$\text{Now, } \cos \theta = \sqrt{1 - \sin^2 \theta} \quad \because \theta \in \left[ -\frac{\pi}{2}, 0 \right]$$

$$\Rightarrow \cos \theta \text{ is +ve} \Rightarrow \cos \theta = \sqrt{1 - \sin^2 \theta}$$

$$\Rightarrow (\cos(-\theta)) = \sqrt{1 - x^2} \text{ as } \theta \in \left[ -\frac{\pi}{2}, 0 \right]$$

$$\Rightarrow -\theta \in \left[ 0, \frac{\pi}{2} \right] \subset [0, \pi] \quad \therefore -\theta = \cos^{-1} \sqrt{1 - x^2}$$

$$\Rightarrow \theta = -\cos^{-1} \sqrt{1 - x^2}$$

$$\therefore \sin^{-1}(x) = -\cos^{-1} \sqrt{1 - x^2}$$

**IInd part**

Let  $x \in (-1, 1)$  and  $\sin^{-1} x = \theta$

$$\Rightarrow \theta \in \left( -\frac{\pi}{2}, \frac{\pi}{2} \right) \text{ and } x = \sin \theta$$

Now,  $\cos \theta = \sqrt{1 - \sin^2 \theta}$

$$[\because \text{In I}^{\text{st}} \text{ and IV}^{\text{th}} \text{ quad. } \cos \theta + \text{ve}]$$

$$\Rightarrow \cos \theta = \sqrt{1 - x^2}$$

$$\therefore \tan \theta = \frac{\sin \theta}{\cos \theta} = \left[ \frac{x}{\sqrt{1 - x^2}} \right]$$

$$\Rightarrow \theta = \tan^{-1} \left( \frac{x}{\sqrt{1 - x^2}} \right) \text{ as } \theta \in \left( -\frac{\pi}{2}, \frac{\pi}{2} \right)$$

$$\therefore \sin^{-1} x = \tan^{-1} \left( \frac{x}{\sqrt{1 - x^2}} \right) \text{ for } x \in (-1, 1)$$

**IIIrd Part**

For  $0 < x \leq 1$ ; and  $\sin^{-1} x = \theta$

$$\theta \in (0, \pi/2] \text{ and } x = \sin \theta$$

$$\text{Now, } \cot \theta = \left( \frac{\cos \theta}{\sin \theta} \right) = \left( \frac{\sqrt{1 - x^2}}{x} \right)$$

$$\Rightarrow \theta = \cot^{-1} \left( \frac{\sqrt{1 - x^2}}{x} \right)$$

**4.30** > Trigonometry

For  $-1 \leq x < 0$  and  $\sin^{-1} x = \theta$

$$\Rightarrow \theta \in \left[-\frac{\pi}{2}, 0\right) \text{ and } x = \sin \theta$$

$$\text{and } \cot \theta = \frac{\cos \theta}{\sin \theta} = \frac{\sqrt{1-\sin^2 \theta}}{\sin \theta} = \frac{\sqrt{1-x^2}}{x}$$

$$\Rightarrow \cot(\pi + \theta) = \frac{\sqrt{1-x^2}}{x}$$

$$\Rightarrow \pi + \theta = \cot^{-1} \left( \frac{\sqrt{1-x^2}}{x} \right)$$

$$\Rightarrow \theta = -\pi + \cot^{-1} \left( \frac{\sqrt{1-x^2}}{x} \right)$$

$$\text{as } \theta \in \left[-\frac{\pi}{2}, 0\right) \Rightarrow \pi + \theta \in \left[\frac{\pi}{2}, \pi\right)$$

$$\therefore \sin^{-1} x = -\pi + \cot^{-1} \left( \frac{\sqrt{1-x^2}}{x} \right)$$

**IVth Part**

For  $0 \leq x < 1$

$$\text{Let } \sin^{-1} x = \theta \Rightarrow \theta \in \left[0, \frac{\pi}{2}\right) \text{ and } x = \sin \theta$$

$$\sec \theta = \frac{1}{\sqrt{1-\sin^2 \theta}} = \frac{1}{\sqrt{1-x^2}}$$

$$\Rightarrow \theta = \sec^{-1} \left( \frac{1}{\sqrt{1-x^2}} \right)$$

For  $-1 < x \leq 0$

$$\sin^{-1} x = \theta \Rightarrow \theta \in \left(-\frac{\pi}{2}, 0\right] \text{ and } x = \sin \theta$$

$$\Rightarrow \cos \theta = \sqrt{1-x^2}$$

$$\Rightarrow \sec \theta = \frac{1}{\sqrt{1-x^2}}$$

$$\Rightarrow \sec(-\theta) = \frac{1}{\sqrt{1-x^2}} \text{ as } -\theta \in \left[0, \frac{\pi}{2}\right)$$

$$\Rightarrow \theta = -\sec^{-1} \left( \frac{1}{\sqrt{1-x^2}} \right)$$

$$\therefore \sin^{-1} x = -\sec^{-1} \left( \frac{1}{\sqrt{1-x^2}} \right)$$

**Vth part**

For  $x \in [-1, 1] \sim \{0\}$  and  $\sin^{-1} x = \theta$

$$\Rightarrow \theta \in \left[-\frac{\pi}{2}, \frac{\pi}{2}\right] \sim \{0\} \text{ and } x = \sin \theta$$

$$\operatorname{cosec} \theta = \frac{1}{\sin \theta} = \frac{1}{x} \Rightarrow \theta = \operatorname{cosec}^{-1} \left( \frac{1}{x} \right)$$

$$\Rightarrow \text{as } \theta \in \left[-\frac{\pi}{2}, \frac{\pi}{2}\right] \sim \{0\}$$

$$\therefore \sin^{-1} x = \operatorname{cosec}^{-1} \left( \frac{1}{x} \right)$$

$$(b) \cos^{-1} x = \begin{cases} \sin^{-1} \sqrt{1-x^2} & \text{for } x \in [0, 1] \\ \pi - \sin^{-1} \sqrt{1-x^2} & \text{for } x \in [-1, 0] \end{cases} \dots(i)$$

$$= \begin{cases} \tan^{-1} \left( \frac{\sqrt{1-x^2}}{x} \right) & \text{for } x \in (0, 1] \\ \pi + \tan^{-1} \frac{\sqrt{1-x^2}}{x} & \text{for } x \in [-1, 0) \end{cases} \dots(ii)$$

$$= \left\{ \cot^{-1} \left( \frac{x}{\sqrt{1-x^2}} \right) \text{ for } x \in (-1, 1) \right\} \dots(iii)$$

$$= \sec^{-1} \left( \frac{1}{x} \right) \text{ for } x \in [-1, 1] \sim \{0\} \dots(iv)$$

$$= \begin{cases} \operatorname{cosec}^{-1} \left( \frac{1}{\sqrt{1-x^2}} \right) & \text{for } x \in [0, 1) \\ \pi - \operatorname{cosec}^{-1} \left( \frac{1}{\sqrt{1-x^2}} \right) & \text{for } x \in (-1, 0] \end{cases} \dots(v)$$

$$(c) \tan^{-1} x = \sin^{-1} \left( \frac{x}{\sqrt{1+x^2}} \right) \text{ for } x \in \mathbb{R}$$

$$= \begin{cases} \cos^{-1} \left( \frac{1}{\sqrt{1+x^2}} \right) & \text{for } x \in [0, 1] \\ -\cos^{-1} \left( \frac{1}{\sqrt{1+x^2}} \right) & \text{for } x \in [-1, 0] \end{cases}$$

$$= \begin{cases} \cot^{-1} \left( \frac{1}{x} \right) & \text{for } x > 0 \\ -\pi + \cot^{-1} \left( \frac{1}{x} \right) & \text{for } x < 0 \end{cases}$$

$$= \begin{cases} \sec^{-1} \left( \sqrt{1+x^2} \right) & \text{for } x > 0 \\ -\sec^{-1} \left( \sqrt{1+x^2} \right) & \text{for } x < 0 \end{cases}$$

$$= \left\{ \operatorname{cosec}^{-1} \left( \frac{\sqrt{1+x^2}}{x} \right) \text{ for } x \in \mathbb{R} \sim \{0\} \right\}$$

$$\begin{aligned}
 \text{(d) } \cot^{-1} x &= \begin{cases} \sin^{-1}\left(\frac{1}{\sqrt{1+x^2}}\right) & \text{for } x \geq 0 \\ \pi - \sin^{-1}\left(\frac{1}{\sqrt{1+x^2}}\right) & \text{for } x \leq 0 \end{cases} \\
 &= \begin{cases} \cos^{-1}\left(\frac{x}{\sqrt{1+x^2}}\right) & \forall x \in \mathbb{R} \end{cases} \\
 &= \begin{cases} \tan^{-1}\left(\frac{1}{x}\right) & \text{for } x > 0 \\ \pi + \tan^{-1}\left(\frac{1}{x}\right) & \text{for } x < 0 \end{cases} \\
 &= \begin{cases} \sec^{-1}\left(\frac{\sqrt{1+x^2}}{x}\right) & \forall x \in \mathbb{R} \sim \{0\} \end{cases} \\
 &= \begin{cases} \operatorname{cosec}^{-1}\left(\sqrt{1+x^2}\right) & \text{for } x > 0 \\ \pi - \operatorname{cosec}^{-1}\left(\sqrt{1+x^2}\right) & \text{for } x < 0 \end{cases} \\
 \text{(e) } \sec^{-1} x &= \begin{cases} \sin^{-1}\left(\frac{\sqrt{x^2-1}}{x}\right) & \text{for } x > 0 \\ \pi + \sin^{-1}\left(\frac{\sqrt{x^2-1}}{x}\right) & \text{for } x < 0 \end{cases} \\
 &= \cos^{-1}\left(\frac{1}{x}\right) \forall x \in \mathbb{R} \sim \{0\} \\
 &= \begin{cases} \tan^{-1}\left(\sqrt{x^2-1}\right) & \text{for } x > 0 \\ \pi - \tan^{-1}\sqrt{x^2-1} & \text{for } x < 0 \end{cases}
 \end{aligned}$$

$$\begin{aligned}
 &= \begin{cases} \cot^{-1}\left(\frac{1}{\sqrt{x^2-1}}\right) & \text{for } x > 0, x \neq 1 \\ \pi - \cot^{-1}\left(\frac{1}{\sqrt{x^2-1}}\right) & \text{for } x < 0, x \neq -1 \end{cases} \\
 &= \begin{cases} \operatorname{cosec}^{-1}\left(\frac{x}{\sqrt{x^2-1}}\right) & \text{for } x > 0 \\ \pi + \operatorname{cosec}^{-1}\left(\frac{x}{\sqrt{x^2-1}}\right) & \text{for } x < 0 \end{cases} \\
 \text{(f) } \operatorname{cosec}^{-1} x &= \sin^{-1} \frac{1}{x} \quad \forall x \in (-\infty, -1] \cup [1, \infty) \\
 &= \begin{cases} \cos^{-1}\left(\frac{\sqrt{x^2-1}}{x}\right); & \text{for } x \geq 1 \\ -\pi + \cos^{-1}\left(\frac{\sqrt{x^2-1}}{x}\right); & \text{for } x \leq -1 \end{cases} \\
 &= \begin{cases} \tan^{-1}\left(\frac{1}{\sqrt{x^2-1}}\right); & \text{for } x > 1 \\ -\tan^{-1}\left(\frac{1}{\sqrt{x^2-1}}\right); & \text{for } x < -1 \end{cases} \\
 &= \begin{cases} \cot^{-1}\left(\sqrt{x^2-1}\right) & \text{for } x \geq 1 \\ -\cot^{-1}\left(\sqrt{x^2-1}\right) & \text{for } x \leq -1 \end{cases} \\
 &= \begin{cases} \sec^{-1}\left(\frac{x}{\sqrt{x^2-1}}\right) & \text{for } x > 1 \\ -\pi + \sec^{-1}\left(\frac{x}{\sqrt{x^2-1}}\right) & \text{for } x < -1 \end{cases}
 \end{aligned}$$

**Proof:** For (b) to (f) are left for students and can be proved on similar lines as is done in part (a).

**ILLUSTRATION 29:** Find the value of  $\tan\left\{\cot^{-1}\left(-\frac{2}{3}\right)\right\}$ .

**SOLUTION:**  $\because \cot^{-1}(-x) = \pi - \cot^{-1} x$

$$\begin{aligned}
 \therefore \tan\left\{\cot^{-1}\left(-\frac{2}{3}\right)\right\} &= \tan\left\{\pi - \cot^{-1}\left(\frac{2}{3}\right)\right\} = -\tan\left\{\cot^{-1}\left(\frac{2}{3}\right)\right\} \\
 &= -\tan\left\{\tan^{-1}\left(\frac{3}{2}\right)\right\} \left[\because \cot^{-1}\left(\frac{1}{x}\right) = \tan^{-1} x \text{ for } x > 0\right] = -\left(\frac{3}{2}\right) \left[\because \tan(\tan^{-1} x) = x \forall x \in \mathbb{R}\right]
 \end{aligned}$$

**ILLUSTRATION 30:** Find the value of  $\left\{ \sin \left\{ \tan^{-1} \frac{3}{4} \right\} \right\}$ ; where  $\{.\}$  is a fractional part function.

**SOLUTION:**  $\because \tan^{-1}x = \sin^{-1} \left( \frac{x}{\sqrt{1+x^2}} \right)$  for  $x > 0 \quad \therefore \tan^{-1} \frac{3}{4} = \sin^{-1} \left( \frac{\frac{3}{4}}{\sqrt{1+\frac{9}{16}}} \right) = \sin^{-1} \left( \frac{3}{5} \right)$

$$\therefore \left\{ \tan^{-1} \frac{3}{4} \right\} = \left\{ \sin^{-1} \frac{3}{5} \right\}$$

$$\because \frac{3}{5} < \frac{1}{\sqrt{2}} \text{ and both belong to } (0, 1) \text{ in which } \sin^{-1}x \text{ is increasing function and } 0 < \frac{3}{5} < \frac{1}{\sqrt{2}}$$

$$\Rightarrow \sin^{-1} 0 < \sin^{-1} \frac{3}{5} < \sin^{-1} \left( \frac{1}{\sqrt{2}} \right) \quad \Rightarrow 0 < \sin^{-1} \frac{3}{5} < \frac{\pi}{4} < 1$$

$$\therefore \sin^{-1} \frac{3}{5} \in (0, 1) \quad \therefore \left\{ \sin^{-1} \frac{3}{5} \right\} = \sin^{-1} \frac{3}{5}$$

$$\therefore \left\{ \sin \left\{ \tan^{-1} \frac{3}{4} \right\} \right\} = \left\{ \sin \left\{ \sin^{-1} \frac{3}{5} \right\} \right\} = \left\{ \sin \left( \sin^{-1} \frac{3}{5} \right) \right\} = \left\{ \frac{3}{5} \right\} = \frac{3}{5}$$

**ILLUSTRATION 31:** Evaluate:

(i)  $\tan^{-1} \left\{ \cot \left( -\frac{1}{4} \right) \right\}$  (ii)  $\sec \left\{ \cos^{-1} \left( \frac{2}{3} \right) \right\}$

(iii)  $\operatorname{cosec} \left\{ \sin^{-1} \left( \frac{-1}{\sqrt{3}} \right) \right\}$  (iv)  $\sin \left\{ \frac{1}{2} \cot^{-1} \left( \frac{-3}{4} \right) \right\}$

**SOLUTION:** (i)  $\tan^{-1} \left\{ \cot \left( -\frac{1}{4} \right) \right\} = \tan^{-1} \left( -\cot \left( \frac{1}{4} \right) \right) [\because \cot(-x) = -\cot x]$

$$= -\tan^{-1} \left( \cot \left( \frac{1}{4} \right) \right) [\because \tan^{-1}(-x) = -\tan^{-1} x]$$

$$= -\tan^{-1} \left[ \tan \left( \frac{\pi}{2} - \frac{1}{4} \right) \right] = -\left( \frac{\pi}{2} - \frac{1}{4} \right) [\because \tan^{-1}(\tan x) = x \forall x \in \mathbb{R}] = \left( \frac{1}{4} - \frac{\pi}{2} \right)$$

(ii)  $\sec \left\{ \cos^{-1} \left( \frac{2}{3} \right) \right\} = \sec \left\{ \sec^{-1} \left( \frac{3}{2} \right) \right\} = \frac{3}{2}$

$$\left[ \because \cos^{-1} \left( \frac{1}{x} \right) = \sec^{-1} x \forall x \geq 1 \text{ \& } \sec(\sec^{-1} x) = x \text{ for } x \in (-\infty, -1] \cup [1, \infty) \right]$$

(iii)  $\operatorname{cosec} \left( \sin^{-1} \left( \frac{-1}{\sqrt{3}} \right) \right) = \operatorname{cosec} \left[ -\sin^{-1} \left( \frac{1}{\sqrt{3}} \right) \right] [\because \sin^{-1}(-x) = -\sin^{-1} x \forall x \in [-1, 1]]$

$$= -\operatorname{cosec} \left[ \sin^{-1} \left( \frac{1}{\sqrt{3}} \right) \right] [\because \operatorname{cosec}(-x) = -\operatorname{cosec} x]$$

$$= -\operatorname{cosec}\left[\operatorname{cosec}^{-1}(\sqrt{3})\right] \left[ \because \sin^{-1}\left(\frac{1}{x}\right) = \operatorname{cosec}^{-1}x \forall x \geq 1 \right]$$

$$= -\sqrt{3} \left[ \because \operatorname{cosec}(\operatorname{cosec}^{-1}x) = x \forall x \in (-\infty, -1] \cup [1, \infty) \right]$$

$$\begin{aligned} \text{(iv) } \sin\left\{\frac{1}{2}\cot^{-1}\left(-\frac{3}{4}\right)\right\} &= \sin\left\{\frac{1}{2}\left(\pi - \cot^{-1}\frac{3}{4}\right)\right\} = \sin\left\{\frac{\pi}{2} - \frac{1}{2}\cot^{-1}\frac{3}{4}\right\} = \cos\left\{\frac{1}{2}\cot^{-1}\frac{3}{4}\right\} \\ &= \cos\left(\frac{\theta}{2}\right) = \sqrt{\frac{1+\cos\theta}{2}} = \sqrt{\frac{1+3/5}{2}} = \sqrt{\frac{8}{10}} = \sqrt{\frac{4}{5}} = \frac{2}{\sqrt{5}} = \frac{2\sqrt{5}}{5}; \end{aligned}$$

$$\text{Where } \theta = \cot^{-1}\frac{3}{4} \in \left(0, \frac{\pi}{2}\right)$$

**ILLUSTRATION 32:** Evaluate  $\left\{\sin\left(2\left\{\tan^{-1}\frac{1}{3}\right\}\right)\right\} + \left\{\cos\left(\tan^{-1}\left(2\sqrt{2}\right)\right)\right\}$ ; where  $\{.\}$  denotes the fractional part function

**SOLUTION:**  $\because 0 < \frac{1}{3} < 1$  and  $\tan^{-1}x$  is an increasing function for  $x \in (-\infty, \infty)$

$$\Rightarrow \tan^{-1}0 < \tan^{-1}\frac{1}{3} < \tan^{-1}1 = \pi/4 < 1$$

$$\Rightarrow 0 < \tan^{-1}\frac{1}{3} < 1$$

$$\Rightarrow \left\{\tan^{-1}\frac{1}{3}\right\} = \tan^{-1}\frac{1}{3} \Rightarrow \left\{\sin\left(2\left\{\tan^{-1}\frac{1}{3}\right\}\right)\right\} = \left\{\sin\left(2\tan^{-1}\frac{1}{3}\right)\right\}$$

$$= \left\{\sin 2\theta\right\} = \left\{\frac{2\tan\theta}{1+\tan^2\theta}\right\} = \left\{\frac{2/3}{1+1/9}\right\}; \text{ where } \theta = \tan^{-1}1/3$$

$$\Rightarrow \left\{\frac{2}{3} \times \frac{9}{10}\right\} = \left\{\frac{3}{5}\right\} = \frac{3}{5}$$

$$\text{Also } \tan^{-1}2\sqrt{2} = \cos^{-1}\frac{1}{3}$$

$$\therefore \cos\left(\tan^{-1}2\sqrt{2}\right) = \cos\left(\cos^{-1}\frac{1}{3}\right) = \frac{1}{3}$$

$$\Rightarrow \left\{\cos\left(\tan^{-1}2\sqrt{2}\right)\right\} = \left\{\frac{1}{3}\right\} = \frac{1}{3}$$

$$\therefore \left\{\sin\left(2\left\{\tan^{-1}\frac{1}{3}\right\}\right)\right\} + \left\{\cos\left(\tan^{-1}2\sqrt{2}\right)\right\} = \frac{3}{5} + \frac{1}{3} = \frac{9+5}{15} = \frac{14}{15}$$

**ILLUSTRATION 33:** Find the value of

$$\cos^{-1}\left[\cot\left\{\sin^{-1}\left(\sqrt{\frac{2-\sqrt{3}}{4}}\right)\right\} + \cos^{-1}\left(\frac{\sqrt{12}}{4}\right) + \sec^{-1}(\sqrt{2})\right]$$



$$\begin{aligned}
\text{SOLUTION: } &= \cos^{-1} \left[ \cot \left\{ \sin^{-1} \sqrt{\frac{(\sqrt{3}-1)^2}{8}} + \cos^{-1} \left( \frac{2\sqrt{3}}{4} \right) + \frac{\pi}{4} \right\} \right] \\
&= \cos^{-1} \left[ \cot \left\{ \sin^{-1} \left( \frac{\sqrt{3}-1}{2\sqrt{2}} \right) + \frac{\pi}{6} + \frac{\pi}{4} \right\} \right] = \cos^{-1} \left[ \cot \left\{ \sin^{-1} \left( \frac{\sqrt{3}}{2} \cdot \frac{1}{\sqrt{2}} - \frac{1}{2} \cdot \frac{1}{\sqrt{2}} \right) + \frac{\pi}{6} + \frac{\pi}{4} \right\} \right] \\
&= \cos^{-1} \left[ \cot \left\{ \sin^{-1} \left( \sin \left( \frac{\pi}{3} - \frac{\pi}{4} \right) \right) + \frac{\pi}{6} + \frac{\pi}{4} \right\} \right] \\
&= \cos^{-1} \left[ \cot \left\{ \frac{\pi}{3} - \frac{\pi}{4} + \frac{\pi}{6} + \frac{\pi}{4} \right\} \right] = \cos^{-1} \left[ \cot \left\{ \frac{\pi}{2} \right\} \right] = \cos^{-1} [0] = \frac{\pi}{2}
\end{aligned}$$

**ILLUSTRATION 34:** Identify the pair(s) of functions which are identical.

$$\begin{aligned}
\text{(a) } y &= \tan(\cos^{-1}x); y = \frac{\sqrt{1-x^2}}{x} & \text{(b) } y &= \tan(\cot^{-1}x); y = \frac{1}{x} \\
\text{(c) } y &= \sin(\tan^{-1}x); y = \frac{x}{\sqrt{1+x^2}} & \text{(d) } y &= \cos(\tan^{-1}x); y = \sin(\cot^{-1}x)
\end{aligned}$$

$$\begin{aligned}
\text{SOLUTION: } \text{(a) } y &= \tan(\cos^{-1}x) = \begin{cases} \tan \left[ \tan^{-1} \left( \frac{\sqrt{1-x^2}}{x} \right) \right] & \text{for } 0 < x \leq 0 \\ \tan \left[ \pi + \tan^{-1} \left( \frac{\sqrt{1-x^2}}{x} \right) \right] & \text{for } -1 \leq x < 0 \end{cases} \\
&= \tan \left[ \tan^{-1} \left( \frac{\sqrt{1-x^2}}{x} \right) \right] \text{ for } \forall x \in [-1, 1] \sim \{0\} = \frac{\sqrt{1-x^2}}{x} \Rightarrow y = \frac{\sqrt{1-x^2}}{x}
\end{aligned}$$

$$\text{i.e., } y = \tan(\cos^{-1}x) = \frac{\sqrt{1-x^2}}{x}; x \in [-1, 1] \sim \{0\}$$

and also domain of both functions is  $y = [-1, 1] \sim \{0\}$

$\therefore$  The two given functions are identical.

$$\text{(b) } y = \tan(\cot^{-1}x) = \begin{cases} \tan \left\{ \tan^{-1} \left( \frac{1}{x} \right) \right\} & \text{for } x > 0 \\ \tan \left\{ \pi + \tan^{-1} \left( \frac{1}{x} \right) \right\} & \text{for } x < 0 \end{cases}$$

$$\Rightarrow y = \tan \left\{ \tan^{-1} \frac{1}{x} \right\} \text{ for } \forall x \in \mathbb{R} \sim \{0\} \Rightarrow y = \frac{1}{x} \forall x \in \mathbb{R} \sim \{0\}$$

$$\text{Domain of } \tan(\cot^{-1}x) \text{ is } \mathbb{R} \sim \left( x : \cot^{-1}x = \frac{\pi}{2} \right) = \mathbb{R} \sim \{0\}$$

$$\text{Also domain of function } f(x) = \frac{1}{x} \text{ is } \mathbb{R} \sim \{0\}$$

$\therefore$  The two given functions are identical.

$$\begin{aligned} \text{(c) } y &= \sin(\tan^{-1}x) = \sin\left(\sin^{-1}\left(\frac{x}{\sqrt{1+x^2}}\right)\right) \\ &= \frac{x}{\sqrt{1+x^2}} \text{ as } 0 \leq \frac{x}{\sqrt{1+x^2}} < 1 \text{ and domain of both functions is } \mathbb{R}. \end{aligned}$$

Thus two given functions are identical.

$$\text{(d) } y = \cos(\tan^{-1}x) = \begin{cases} \cos\left[\cos^{-1}\frac{1}{\sqrt{1+x^2}}\right]; & \text{for } x \geq 0 \\ \cos\left[-\cos^{-1}\left(\frac{1}{\sqrt{1+x^2}}\right)\right] & \text{for } x < 0 \end{cases}$$

$$= \forall x \in \mathbb{R}; y = \cos\left(\cos^{-1}\left(\frac{1}{\sqrt{1+x^2}}\right)\right) = \frac{1}{\sqrt{1+x^2}} \text{ as } \frac{1}{\sqrt{1+x^2}} \in (0, 1]$$

Also its domain =  $\mathbb{R}$

$$\text{and } y = \sin(\cot^{-1}x) = \begin{cases} \sin\left[\sin^{-1}\left(\frac{1}{\sqrt{1+x^2}}\right)\right] & \text{for } x \geq 0 \\ \sin\left[\pi - \sin^{-1}\left(\frac{1}{\sqrt{1+x^2}}\right)\right] & \text{for } x < 0 \end{cases}$$

$$= \forall x \in \mathbb{R}; y = \sin\left(\sin^{-1}\left(\frac{1}{\sqrt{1+x^2}}\right)\right) = \frac{1}{\sqrt{1+x^2}} \text{ as } \frac{1}{\sqrt{1+x^2}} \in (0, 1]$$

Also domain of both the given functions is  $\mathbb{R}$

∴ The two given functions are identical.

### TEXTUAL EXERCISE-3 (SUBJECTIVE)

- Find the value of  $\cos^{-1}\left(\cos\frac{7\pi}{6}\right)$
  - Find the value of  $\sin\left[\frac{\pi}{2} - \sin^{-1}\left(-\frac{\sqrt{3}}{2}\right)\right]$ .
  - Find the value of  $\sin\left[\arccos\left(-\frac{1}{2}\right)\right]$ .
  - Find the value of  $\sin\left[\tan^{-1}(-\sqrt{3}) + \cos^{-1}\left(-\frac{\sqrt{3}}{2}\right)\right]$ .

2. Evaluate the following:

- $\sin(\cos^{-1} 3/5)$
- $\cos(\tan^{-1} 3/4)$
- $\sin(\pi/2 - \sin^{-1}(-1/2))$

$$\text{(d) } \sin(\pi/2 - \sin^{-1}(-\sqrt{3}/2))$$

$$\text{(e) } \sin(\cot^{-1}x)$$

3. Prove that:

$$\text{(a) } \tan^{-1}x = 2 \tan^{-1}[\operatorname{cosec} \tan^{-1}x - \tan \cot^{-1}x].$$

$$\text{(b) } \sin \cot^{-1} \tan \cos^{-1}x = x; \text{ if } x \in (0, 1] \text{ and } -x \text{ if } x \in [-1, 0)$$

$$\text{(c) } \cos \tan^{-1} \sin \cot^{-1}x = \sqrt{\frac{x^2+1}{x^2+2}}$$

$$\text{(d) } \tan^{-1}x + \cot^{-1}(1+x) = \tan^{-1}(1+x+x^2)$$

$$\text{(e) } \tan^{-1}\left(\frac{x}{\sqrt{a^2-x^2}}\right) = \sin^{-1}\left(\frac{x}{a}\right), a > 0$$

$$\text{(f) } \tan^{-1}\left(\frac{\cos x}{1+\sin x}\right) = \frac{\pi}{4} - \frac{x}{2}, \frac{\pi}{2} < x < \frac{3\pi}{2}$$

4.36 > Trigonometry

4. Express

(a)  $\cos^{-1}\left(-\frac{1}{3}\right)$

(b)  $\tan^{-1}\left(-\frac{7}{24}\right)$

(c)  $\cot^{-1}\left(-\frac{7}{24}\right)$  in terms of value of each of the three other inverse trigonometric function

5. Prove that  $\sin \operatorname{cosec}^{-1} \cot \tan^{-1} x = x$ , where  $x \in (0, 1]$

6. If  $y = \tan^{-1} \left[ \frac{\sqrt{1+x^2} - \sqrt{1-x^2}}{\sqrt{1+x^2} + \sqrt{1-x^2}} \right]$ ; prove that  $x^2 = \sin 2y$

7. Show that  $\operatorname{cosec} \tan^{-1} \cos \cot^{-1} \sec \sin^{-1} a = \sec \cdot \cot^{-1} \sin \tan^{-1} \operatorname{cosec} \cos^{-1} a$ , where  $0 \leq a \leq 1$

8. If  $\sin(\cot^{-1}(x+1)) = \cos(\tan^{-1} x)$ , then find the value of  $x$

9. If  $0 < x < 1$ , then find the value of  $\sqrt{1+x^2} \left[ \left\{ x \cos(\cot^{-1} x) + \sin(\cot^{-1} x) \right\}^2 - 1 \right]^{1/2}$  in simplified algebraic form.

10. Prove the following

(a)  $\tan\left(\frac{1}{2} \cos^{-1} \frac{\sqrt{5}}{3}\right) = \frac{3-\sqrt{5}}{2}$

(b)  $\sin(\tan^{-1} 2) + \cos(\tan^{-1} 2) = \frac{3}{\sqrt{5}}$

**Answer Keys**

1. (a)  $\frac{5\pi}{6}$  (b)  $\frac{1}{2}$  (c)  $\frac{\sqrt{3}}{2}$  (d) 1 2. (a) 4/5 (b) 4/5 (c)  $\sqrt{3}/2$  (d) 1/2 (e)  $\frac{1}{\sqrt{1+x^2}}$

4. (a)  $\pi - \sin^{-1} \frac{2\sqrt{2}}{3}, \pi - \tan^{-1} 2\sqrt{2}, \cot^{-1} \left(-\frac{\sqrt{2}}{4}\right)$  (b)  $\sin^{-1} \left(-\frac{7}{25}\right), -\cos^{-1} \frac{24}{25}, -\cot^{-1} \frac{24}{7}$

(c)  $\pi - \sin^{-1} \frac{24}{25}, \pi - \tan^{-1} \frac{24}{7}, \pi - \cot^{-1} \frac{7}{24}$

8. -1/2

9.  $\sqrt{1+x^2} |x|$

**TEXTUAL EXERCISE-3 (OBJECTIVE)**

1.  $\sin(\sin^{-1} 1/2 + \cos^{-1} 1/3)$  is equal to

(a)  $\frac{\sqrt{3} + \sqrt{8}}{6}$

(b)  $\frac{1+2\sqrt{6}}{6}$

(c)  $-\frac{1+2\sqrt{6}}{6}$

(d) 0

2. If  $f(x) = e^{\cos \cos^{-1} x^2 + \tan \cot^{-1} x^2}$  then minimum value of  $f(x)$  is

(a)  $e$

(b)  $e^2$

(c)  $e^{2/3}$

(d) None of these

3.  $\cos^{-1}(2x-1)$  is equal to

(a)  $\sin^{-1}(2\sqrt{x-x^2})$  if  $0 \leq x \leq 1$

(b)  $\pi - \sin^{-1}(2\sqrt{x-x^2})$  if  $0 \leq x \leq 1/2$

(c)  $\sin^{-1}(2\sqrt{x-x^2})$  if  $1/2 \leq x \leq 1$

(d) None of these

4.  $\sin^{-1}\left(\frac{2x+1}{3}\right)$  is equal to

(a)  $-\cos^{-1}\left(\frac{2}{3}\sqrt{2-x-x^2}\right)$  if  $-2 \leq x \leq 1/2$

(b)  $\cos^{-1}\left(\frac{2}{3}\sqrt{2-x-x^2}\right)$  if  $-1/2 \leq x \leq 1$

(c)  $\cos^{-1}\left(\frac{2}{3}\sqrt{2-(x+x^2)}\right)$  if  $-2 \leq x \leq 1$

(d) None of these

5.  $\cos^{-1}\left(\frac{x+1}{2}\right)$  is equal to

(a)  $\tan^{-1}\left(\frac{\sqrt{3-x(2+x)}}{x+1}\right)$  if  $-3 \leq x \leq 1$

(b)  $-\tan^{-1}\left(\frac{\sqrt{3-2x-x^2}}{x+1}\right)$  if  $-3 \leq x \leq -1$

(c)  $\pi + \tan^{-1}\left(\frac{\sqrt{3-2x-x^2}}{x+1}\right)$  if  $-3 \leq x \leq -1$

(d)  $\tan^{-1}\left(\frac{\sqrt{3-x(2+x)}}{x+1}\right)$  if  $-1 < x \leq 1$

6. Which of the following is/are correct?

(a)  $[\cos(\sin^{-1} x)]^2 = [\sin(\cos^{-1} x)]^2$

(b)  $[\cos(\cos^{-1} x)]^2 = [\sin(\cos^{-1} x)]^2$

(c)  $[\sin(\sin^{-1} x)]^2 = [\cos(\cos^{-1} x)]^2$

(d)  $[\sin(\cos^{-1} x)]^2 = \left[\frac{\pi}{2} \sin(\sin^{-1} x)\right]^2$

 7. If  $\cos^{-1}\left(\frac{1}{x}\right) = \theta$ , then  $\tan \theta =$ 

(a)  $-\sqrt{x^2-1}$  if  $x \in (-\infty, -1]$

(b)  $\sqrt{x^2+1}$  if  $x \in \mathbb{R} \sim (-1, 1)$

(c)  $\sqrt{1-x^2}$  if  $x \in \mathbb{R} \sim (-1, 1)$

(d)  $\sqrt{x^2-1}$  if  $x \in [1, \infty)$

 8. If  $\cos(2\sin^{-1} x) = \frac{1}{9}$ , then  $x$  is equal to

(a) Only  $\frac{2}{3}$

(b) Only  $-\frac{2}{3}$

(c)  $\frac{2}{3}, -\frac{2}{3}$

(d) Neither  $\frac{2}{3}$  nor  $-\frac{2}{3}$

 9.  $\cos\left[\tan^{-1}\frac{1}{3} + \tan^{-1}\frac{1}{2}\right]$  is equal to

(a)  $\frac{1}{\sqrt{2}}$

(b)  $\frac{\sqrt{3}}{2}$

(c)  $\frac{1}{2}$

(d)  $\frac{\pi}{4}$

 10.  $\tan\left[2\tan^{-1}\left(\frac{1}{5}\right) - \frac{\pi}{4}\right]$  is equal to

(a)  $\frac{17}{7}$

(b)  $-\frac{17}{7}$

(c)  $\frac{7}{17}$

(d)  $-\frac{7}{17}$

 11.  $\cos\left[2\cos^{-1}\frac{1}{5} + \sin^{-1}\frac{1}{5}\right]$  is equal to

(a)  $\frac{2\sqrt{6}}{5}$

(b)  $-\frac{2\sqrt{6}}{5}$

(c)  $\frac{1}{5}$

(d)  $-\frac{1}{5}$

 12.  $\tan\left[\frac{1}{2}\cos^{-1}\left(\frac{\sqrt{5}}{3}\right)\right]$  is equal to

(a)  $\frac{3-\sqrt{5}}{2}$

(b)  $\frac{3+\sqrt{5}}{2}$

(c)  $\frac{2}{3-\sqrt{5}}$

(d)  $\frac{2}{3+\sqrt{5}}$

 13. If  $\sin\left(\sin^{-1}\frac{1}{5} + \cos^{-1} x\right) = 1$ , then  $x$  is equal to

(a) 1

(b) 1

(c)  $\frac{4}{5}$

(d)  $\frac{1}{5}$

 14. The set of values of  $x$  satisfying  $x^2 - x - \pi + \sin^{-1}(\sin 2) < 0$ , is

(a) (0, 1)

(b) (1, 2)

(c) (-1, 2)

(d) null set

## Answer Keys

1. (b)    2. (b)    3. (b, c)    4. (a, b)    5. (c, d)    6. (a, c)    7. (a, d)    8. (c)    9. (a)    10. (d)  
 11. (b)    12. (a)    13. (d)    14. (c)

### ■ THREE IMPORTANT IDENTITIES OF INVERSE TRIGONOMETRIC FUNCTIONS

- (i)  $\sin^{-1}x + \cos^{-1}x = \pi/2$ , for all  $x \in [-1, 1]$   
 (ii)  $\tan^{-1}x + \cot^{-1}x = \pi/2$ , for all  $x \in \mathbb{R}$   
 (iii)  $\sec^{-1}x + \operatorname{cosec}^{-1}x = \pi/2$ , for all  $x \in (-\infty, -1] \cup [1, \infty)$

**Proof:** Let  $\sin^{-1}x = \theta$  ..... (i)

then,  $\theta \in [-\pi/2, \pi/2] \{ \because x \in [-1, 1] \}$

$$\Rightarrow -\pi/2 \leq \theta \leq \pi/2 \Rightarrow -\pi/2 \leq -\theta \leq \pi/2$$

$$\Rightarrow 0 \leq \pi/2 - \theta \leq \pi \Rightarrow \pi/2 - \theta \in [0, \pi]$$

$$\text{Now } \sin^{-1}x = \theta \Rightarrow x = \sin\theta$$

4.38 > Trigonometry

$$\Rightarrow x = \cos\left(\frac{\pi}{2} - \theta\right) \Rightarrow \cos^{-1}x = \pi/2 - \theta$$

$$\{\because x \in [-1, 1] \text{ and } (\pi/2 - \theta) \in [0, \pi]\}$$

$$\Rightarrow \theta + \cos^{-1}x = \pi/2 \quad \dots (ii)$$

from (i) and (ii), we get

$$\Rightarrow \sin^{-1}x + \cos^{-1}x = \pi/2$$

$$(ii) \text{ Let } \tan^{-1}x = \theta \quad \dots (i)$$

$$\text{then, } \theta \in (-\pi/2, \pi/2) \{\because x \in \mathbb{R}\}$$

$$\Rightarrow -\pi/2 < \theta < \pi/2 \Rightarrow -\pi/2 < -\theta < \pi/2$$

$$\Rightarrow 0 < \pi/2 - \theta < \pi$$

$$\Rightarrow \left(\frac{\pi}{2} - \theta\right) \in (0, \pi)$$

Now,  $\tan^{-1}x = \theta$

$$\Rightarrow x = \tan\theta \Rightarrow x = \cot(\pi/2 - \theta)$$

$$\Rightarrow \cot^{-1}x = \pi/2 - \theta \{\because \pi/2 - \theta \in (0, \pi)\}$$

$$\Rightarrow \theta + \cot^{-1}x = \pi/2 \quad \dots (ii)$$

from (i) and (ii), we get,  $\tan^{-1}x + \cot^{-1}x = \pi/2$

$$(iii) \text{ Let } \sec^{-1}x = \theta \quad \dots (i)$$

$$\text{then, } \theta \in [0, \pi] - \{\pi/2\} \{\because x \in (-\infty, -1] \cup [1, \infty)\}$$

$$\Rightarrow 0 \leq \theta \leq \pi, \theta \neq \pi/2 \Rightarrow -\pi \leq -\theta \leq 0, \theta \neq \frac{\pi}{2}$$

$$\Rightarrow -\frac{\pi}{2} \leq \frac{\pi}{2} - \theta \leq \frac{\pi}{2}, \frac{\pi}{2} - \theta \neq 0$$

$$\Rightarrow \left(\frac{\pi}{2} - \theta\right) \in \left[-\frac{\pi}{2}, \frac{\pi}{2}\right], \frac{\pi}{2} - \theta \neq 0$$

Now,  $\sec^{-1}x = \theta$

$$\Rightarrow x = \sec\theta \Rightarrow x = \operatorname{cosec}(\pi/2 - \theta)$$

$$\Rightarrow \operatorname{cosec}^{-1}x = \pi/2 - \theta$$

$$\left\{\because \left(\frac{\pi}{2} - \theta\right) \in \left[-\frac{\pi}{2}, \frac{\pi}{2}\right], \frac{\pi}{2} - \theta \neq 0\right\}$$

$$\Rightarrow \theta + \operatorname{cosec}^{-1}x = \pi/2 \quad \dots (ii)$$

from (i) and (ii); we get,  $\sec^{-1}x + \operatorname{cosec}^{-1}x = \pi/2$ .

**ILLUSTRATION 35:** Solve for real values of  $x$ :  $\frac{(\sec^{-1}x)^3 + (\operatorname{cosec}^{-1}x)^3}{(\tan^{-1}x + \cot^{-1}x)^3} = 7$

**SOLUTION:** 
$$\frac{(\sec^{-1}x + \operatorname{cosec}^{-1}x)^3 - 3\sec^{-1}x \operatorname{cosec}^{-1}x (\sec^{-1}x + \operatorname{cosec}^{-1}x)}{\left(\frac{\pi}{2}\right)^3} = 7$$

$$\Rightarrow \frac{\pi^3}{8} - 3\sec^{-1}x \operatorname{cosec}^{-1}x \cdot \frac{\pi}{2} = \frac{7\pi^3}{8} \Rightarrow \frac{3\pi}{2} \sec^{-1}x \operatorname{cosec}^{-1}x = \frac{-3}{4}\pi^3$$

$$\Rightarrow \sec^{-1}x \left(\frac{\pi}{2} - \sec^{-1}x\right) = \frac{-\pi^2}{2} \Rightarrow t^2 - \frac{\pi}{2}t - \frac{\pi^2}{2} = 0; t = \sec^{-1}x$$

$$\Rightarrow 2t^2 - \pi t - \pi^2 = 0 \Rightarrow 2t^2 - 2\pi t + \pi t - \pi^2 = 0 \Rightarrow 2t(t - \pi) + \pi(t - \pi) = 0$$

$$\Rightarrow (t - \pi)(2t + \pi) = 0 \Rightarrow t = \pi \text{ or } -\frac{\pi}{2} \Rightarrow \sec^{-1}x = \pi \text{ or } \sec^{-1}x = \frac{-\pi}{2}$$

$$\text{But } \sec^{-1}x \in [0, \pi] \sim \left\{\frac{\pi}{2}\right\} \Rightarrow \sec^{-1}x = \pi \Rightarrow x = -1$$

**ILLUSTRATION 36:** Solve the inequality  $\frac{(2\sin^{-1}x - \pi)}{(3\cos^{-1}x - \pi)} \leq 0$

**SOLUTION:** 
$$\frac{2\sin^{-1}x - \pi}{3\cos^{-1}x - \pi} \leq 0$$

$$\Rightarrow (2\sin^{-1}x - \pi)(3\cos^{-1}x - \pi) \leq 0; \cos^{-1}x \neq \pi/3 \text{ i.e., } \sin^{-1}x \neq \pi/6.$$

$$\begin{aligned} &\Rightarrow (2 \sin^{-1} x - \pi) \left[ 3 \left( \frac{\pi}{2} - \sin^{-1} x \right) - \pi \right] \leq 0 \\ &\quad \left[ \because \sin^{-1} x + \cos^{-1} x = \frac{\pi}{2} \right] \\ &\Rightarrow (2 \sin^{-1} x - \pi) \left[ \frac{\pi}{2} - 3 \sin^{-1} x \right] \leq 0 \Rightarrow (2 \sin^{-1} x - \pi) \left( 3 \sin^{-1} x - \frac{\pi}{2} \right) \geq 0 ; \sin^{-1} x \neq \pi/6 \\ &\Rightarrow \sin^{-1} x \leq \frac{\pi}{6} \text{ or } \sin^{-1} x \geq \frac{\pi}{2}; \sin^{-1} x \neq \pi/6 \Rightarrow \sin^{-1} x \in \left[ -\frac{\pi}{2}, \frac{\pi}{6} \right) \cup \left\{ \frac{\pi}{2} \right\} \Rightarrow x \in \left[ -1, \frac{1}{2} \right) \cup \{1\} \end{aligned}$$

## MULTIPLES OF INVERSE TRIGONOMETRIC FUNCTIONS

### Property (1)

$$2 \sin^{-1} x = \begin{cases} \sin^{-1}(2x\sqrt{1-x^2}), & \text{if } -\frac{1}{\sqrt{2}} \leq x \leq \frac{1}{\sqrt{2}} \\ \pi - \sin^{-1}(2x\sqrt{1-x^2}), & \text{if } \frac{1}{\sqrt{2}} \leq x \leq 1 \\ -\pi - \sin^{-1}(2x\sqrt{1-x^2}), & \text{if } -1 \leq x \leq -\frac{1}{\sqrt{2}} \end{cases}$$

### Property (2)

$$3 \sin^{-1} x = \begin{cases} \sin^{-1}(3x - 4x^3), & \text{if } -\frac{1}{2} \leq x \leq \frac{1}{2} \\ \pi - \sin^{-1}(3x - 4x^3), & \text{if } \frac{1}{2} \leq x \leq 1 \\ -\pi - \sin^{-1}(3x - 4x^3), & \text{if } -1 \leq x \leq -\frac{1}{2} \end{cases}$$

**Proof (1):** Let,  $\sin^{-1} x = \theta$  then  $x = \sin \theta$ ,

$$\Rightarrow \cos \theta = \sqrt{1-x^2} \quad \{ \because \cos \theta > 0 \text{ for } \theta \in [-\pi/2, \pi/2] \}$$

$$\therefore \sin 2\theta = 2 \sin \theta \cos \theta \Rightarrow \sin 2\theta = 2x\sqrt{1-x^2} \quad \dots(i)$$

**Case I:** When  $-\frac{1}{\sqrt{2}} \leq x \leq \frac{1}{\sqrt{2}}$ :

$$-\frac{1}{\sqrt{2}} \leq x \leq \frac{1}{\sqrt{2}} \Rightarrow -\frac{\pi}{4} \leq \theta \leq \frac{\pi}{4}$$

$$\Rightarrow -\frac{\pi}{2} \leq 2\theta \leq \frac{\pi}{2}$$

$$\text{Also, } -\frac{1}{\sqrt{2}} \leq x \leq \frac{1}{\sqrt{2}} \Rightarrow -1 \leq 2x\sqrt{1-x^2} \leq 1$$

$$\therefore \sin 2\theta = 2x\sqrt{1-x^2} \quad \{ \text{from (i)} \}$$

$$\Rightarrow 2\theta = \sin^{-1}(2x\sqrt{1-x^2})$$

$$\Rightarrow 2 \sin^{-1} x = \sin^{-1}(2x\sqrt{1-x^2})$$

**Case II:** When  $\frac{1}{\sqrt{2}} \leq x \leq 1$ :

$$\frac{1}{\sqrt{2}} \leq x \leq 1 \Rightarrow \frac{1}{\sqrt{2}} \leq \sin \theta \leq 1$$

$$\Rightarrow \frac{\pi}{4} \leq \theta \leq \frac{\pi}{2} \Rightarrow \frac{\pi}{2} \leq 2\theta \leq \pi$$

$$\Rightarrow -\pi \leq -2\theta \leq -\pi/2$$

$$\Rightarrow 0 \leq \pi - 2\theta \leq \pi/2$$

$$\text{Also, } \frac{1}{\sqrt{2}} \leq x \leq 1 \Rightarrow 0 \leq 2x\sqrt{1-x^2} < 1$$

$$\therefore \sin 2\theta = 2x\sqrt{1-x^2} \quad \{ \text{from (i)} \}$$

$$\Rightarrow \sin(\pi - 2\theta) = 2x\sqrt{1-x^2}$$

$$\Rightarrow \pi - 2\theta = \sin^{-1}(2x\sqrt{1-x^2})$$

$$\Rightarrow \pi - 2 \sin^{-1} x = \sin^{-1}(2x\sqrt{1-x^2})$$

$$\Rightarrow 2 \sin^{-1} x = \pi - \sin^{-1}(2x\sqrt{1-x^2})$$

**Case III:** When  $-1 \leq x \leq -\frac{1}{\sqrt{2}}$ :

$$-1 \leq x \leq -\frac{1}{\sqrt{2}} \Rightarrow -1 \leq \sin \theta \leq -\frac{1}{\sqrt{2}}$$

$$\Rightarrow -\frac{\pi}{2} \leq \theta \leq -\frac{\pi}{4} \Rightarrow -\pi \leq 2\theta \leq -\pi/2$$

4.40 > Trigonometry

$$\Rightarrow 0 \leq \pi + 2\theta \leq \pi/2$$

$$\text{Also, } -1 \leq x \leq -\frac{1}{\sqrt{2}} \Rightarrow -1 \leq 2x\sqrt{1-x^2} \leq 0$$

$$\therefore \sin 2 = 2x\sqrt{1-x^2} \quad \{ \text{from (i)} \}$$

$$\Rightarrow -\sin(\pi + 2\theta) = 2x\sqrt{1-x^2}$$

$$\Rightarrow \sin(-\pi - 2\theta) = 2x\sqrt{1-x^2}$$

$$\Rightarrow -\pi - 2\theta = \sin^{-1}(2x\sqrt{1-x^2})$$

$$\Rightarrow -\pi - 2\sin^{-1}x = \sin^{-1}(2x\sqrt{1-x^2})$$

$$\Rightarrow 2\sin^{-1}x = -\pi - \sin^{-1}(2x\sqrt{1-x^2})$$

The graph of  $\sin^{-1}(2x\sqrt{1-x^2})$  is as shown in diagram given below.

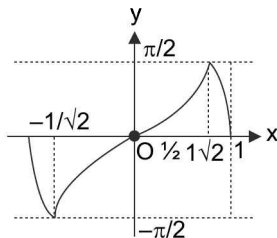

FIGURE 4.27

**Proof (2):** Let,  $\sin^{-1}x = \theta$ . Then,  $x = \sin\theta$

$$\therefore \sin 3\theta = 3\sin\theta - 4\sin^3\theta \Rightarrow \sin 3\theta = 3x - 4x^3$$

**Case I:** when  $-\frac{1}{2} \leq x \leq \frac{1}{2}$ :

If  $-\frac{1}{2} \leq x \leq \frac{1}{2}$ , then

$$-\frac{1}{2} \leq \sin\theta \leq \frac{1}{2} \Rightarrow -\frac{\pi}{6} \leq \theta \leq \frac{\pi}{6} \Rightarrow -\frac{\pi}{2} \leq 3\theta \leq \frac{\pi}{2}$$

$$\text{Also, } -\frac{1}{2} \leq x \leq \frac{1}{2} \Rightarrow -1 \leq 3x - 4x^3 \leq 1$$

$$\therefore \sin 3\theta = 3x - 4x^3 \Rightarrow 3\theta = \sin^{-1}(3x - 4x^3)$$

$$\Rightarrow 3\sin^{-1}x = \sin^{-1}(3x - 4x^3).$$

**Case II:** When  $1/2 \leq x \leq 1$ ;

$$\frac{1}{2} \leq x \leq 1 \Rightarrow \frac{1}{2} \leq \sin\theta \leq 1$$

$$\Rightarrow \frac{\pi}{6} \leq \theta \leq \frac{\pi}{2} \Rightarrow \frac{\pi}{2} \leq 3\theta \leq \frac{3\pi}{2}$$

$$\Rightarrow -\frac{3\pi}{2} \leq -3\theta \leq -\frac{\pi}{2} \Rightarrow -\frac{\pi}{2} \leq \pi - 3\theta \leq \frac{\pi}{2}$$

$$\text{Also, } 1/2 \leq x \leq 1 \Rightarrow -1 \leq 3x - 4x^3 \leq 1.$$

$$\therefore \sin 3\theta = (3x - 4x^3) \Rightarrow \sin(\pi - 3\theta) = (3x - 4x^3).$$

$$\Rightarrow \pi - 3\theta = \sin^{-1}(3x - 4x^3) \Rightarrow \pi - 3\sin^{-1}x = \sin^{-1}(3x - 4x^3)$$

$$\Rightarrow 3\sin^{-1}x = \pi - \sin^{-1}(3x - 4x^3)$$

**Case III:** When  $-1 \leq x \leq -1/2$ :  $-1 \leq x \leq -1/2 \Rightarrow -1 \leq \sin\theta \leq -1/2$

$$\Rightarrow -\frac{\pi}{2} \leq \theta \leq -\frac{\pi}{6} \Rightarrow -\frac{3\pi}{2} \leq 3\theta \leq -\frac{\pi}{2}$$

$$\Rightarrow -\frac{\pi}{2} \leq \pi + 3\theta \leq \frac{\pi}{2} \text{ Also, } -\frac{1}{2} \leq x \leq \frac{1}{2}$$

$$\Rightarrow -1 \leq 3x - 4x^3 \leq 1 \therefore \sin 3\theta = 3x - 4x^3$$

$$\Rightarrow -\sin(\pi + 3\theta) = 3x - 4x^3 \{ \sin(\pi + 3\theta) = -\sin 3\theta \}$$

$$\Rightarrow \sin(-\pi - 3\theta) = 3x - 4x^3$$

$$\Rightarrow -\pi - 3\theta = \sin^{-1}(3x - 4x^3)$$

$$\Rightarrow -\pi - 3\sin^{-1}x = \sin^{-1}(3x - 4x^3)$$

$$\Rightarrow 3\sin^{-1}x = -\pi - \sin^{-1}(3x - 4x^3).$$

The graph of  $\sin^{-1}(3x - 4x^3)$  is as shown in diagram given below.

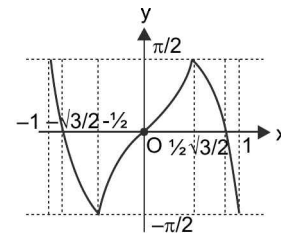

FIGURE 4.28

**Property (3)**

$$2\cos^{-1}x = \begin{cases} \cos^{-1}(2x^2 - 1); & \text{if } 0 \leq x \leq 1 \\ 2\pi - \cos^{-1}(2x^2 - 1); & \text{if } -1 \leq x \leq 0 \end{cases}$$

**Property (4)**

$$3\cos^{-1}x = \begin{cases} \cos^{-1}(4x^3 - 3x); & \text{if } \frac{1}{2} \leq x \leq 1 \\ 2\pi - \cos^{-1}(4x^3 - 3x); & \text{if } -\frac{1}{2} \leq x \leq \frac{1}{2} \\ 2\pi + \cos^{-1}(4x^3 - 3x); & \text{if } -1 \leq x \leq -\frac{1}{2} \end{cases}$$

**Proof (3):** Let  $\cos^{-1} x = \theta$ , then  $x = \cos \theta$   
 $\therefore \cos 2\theta = 2 \cos^2 \theta - 1 = 2x^2 - 1$

**Case (i):** When  $0 \leq x \leq 1 : 0 \leq x \leq 1 \Rightarrow 0 \leq \cos \theta \leq 1$   
 $\Rightarrow 0 \leq \theta \leq \pi/2$   
 $\Rightarrow 0 \leq 2\theta \leq \pi$  Also,  $0 \leq x \leq 1$   
 $\Rightarrow -1 \leq 2x^2 - 1 \leq 1 \therefore \cos 2\theta = 2x^2 - 1$   
 $\Rightarrow 2\theta = \cos^{-1}(2x^2 - 1)$   
 $\Rightarrow 2 \cos^{-1} x = \cos^{-1}(2x^2 - 1)$

**Case (ii):** When  $-1 \leq x \leq 0 : -1 \leq x \leq 0 \Rightarrow -1 \leq \cos \theta \leq 0$   
 $\Rightarrow \pi/2 \leq \theta \leq \pi \Rightarrow 0 \leq 2\pi - 2\theta \leq \pi$   
 Also,  $1 \leq x \leq 0 \Rightarrow -1 \leq 2x^2 - 1 \leq 1$   
 $\therefore \cos 2\theta = (2x^2 - 1) \Rightarrow \cos(2\pi - 2\theta) = 2x^2 - 1$

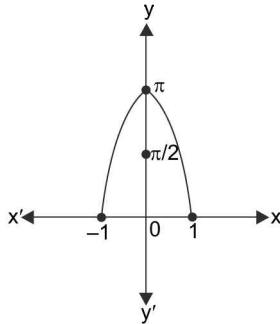

FIGURE 4.29

$$\begin{aligned} \Rightarrow 2\pi - 2\theta &= \cos^{-1}(2x^2 - 1) \\ \Rightarrow 2\pi - 2 \cos^{-1} x &= \cos^{-1}(2x^2 - 1) \\ \Rightarrow 2 \cos^{-1} x &= 2\pi - \cos^{-1}(2x^2 - 1) \end{aligned}$$

The graph of  $\cos^{-1}(2x^2 - 1)$  is as shown in diagram given above.

**Proof (4):** Let  $\cos^{-1} x = \theta$ . Then,  $x = \cos \theta$ ,  $\therefore \cos 3\theta = 4 \cos^3 \theta - 3 \cos \theta$   
 $\Rightarrow \cos 3\theta = 4x^3 - 3x$ .

**Case (i):** When  $1/2 \leq x \leq 1$

$$\begin{aligned} \therefore 1/2 \leq x \leq 1 &\Rightarrow 1/2 \leq \cos \theta \leq 1 \Rightarrow 0 \leq \theta \leq \pi/3 \\ \Rightarrow 0 \leq 3\theta &\leq \pi \text{ Also, } 1/2 \leq x \leq 1 \\ \Rightarrow -1 \leq 4x^3 - 3x &\leq 1 \\ \therefore \cos 3\theta &= 4x^3 - 3x \Rightarrow 3\theta = \cos^{-1}(4x^3 - 3x) \\ \Rightarrow 3 \cos^{-1} x &= \cos^{-1}(4x^3 - 3x) \end{aligned}$$

**Case (ii):** When  $-1/2 \leq x \leq 1/2; \Rightarrow -1/2 \leq x \leq 1/2$

$$\begin{aligned} \Rightarrow -1/2 \leq \cos \theta &\leq 1/2 \Rightarrow \pi/3 \leq \theta \leq \frac{2\pi}{3} \\ \Rightarrow \pi \leq 3\theta &\leq 2\pi \Rightarrow -2\pi \leq -3\theta \leq -\pi \Rightarrow 0 \leq 2\pi - 3\theta \leq \pi \\ \therefore \cos 3\theta &= 4x^3 - 3x \Rightarrow \cos(2\pi - 3\theta) = (4x^3 - 3x) \\ \Rightarrow 2\pi - 3\theta &= \cos^{-1}(4x^3 - 3x) \Rightarrow 3\theta = 2\pi - \cos^{-1}(4x^3 - 3x) \\ \Rightarrow 3 \cos^{-1} x &= 2\pi - \cos^{-1}(4x^3 - 3x) \end{aligned}$$

**Case (iii):** When  $-1 \leq x \leq -1/2$

$$\begin{aligned} -1 \leq x \leq -1/2 &\Rightarrow -1 \leq \cos \theta \leq -1/2 \\ \Rightarrow \frac{2\pi}{3} \leq \theta &\leq \pi. \Rightarrow 2\pi \leq 3\theta \leq 3\pi \\ \Rightarrow -3\pi \leq -3\theta &\leq -2\pi \Rightarrow -\pi \leq 2\pi - 3\theta \leq 0 \\ \Rightarrow 0 \leq 3\theta - 2\pi &\leq \pi. \therefore \cos 3\theta = 4x^3 - 3x \end{aligned}$$

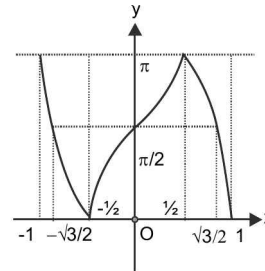

FIGURE 4.30

$$\begin{aligned} \Rightarrow \cos(3\theta - 2\pi) &= 4x^3 - 3x \\ \Rightarrow 3\theta - 2\pi &= \cos^{-1}(4x^3 - 3x) \\ \Rightarrow 3\theta &= 2\pi + \cos^{-1}(4x^3 - 3x) \\ \Rightarrow 3 \cos^{-1} x &= 2\pi + \cos^{-1}(4x^3 - 3x) \end{aligned}$$

The graph of  $\cos^{-1}(4x^3 - 3x)$  is as shown in diagram given above.

**Property (5)**

$$2 \tan^{-1} x = \begin{cases} \tan^{-1}\left(\frac{2x}{1-x^2}\right); & \text{if } -1 < x < 1 \\ \pi + \tan^{-1}\left(\frac{2x}{1-x^2}\right); & \text{if } x > 1 \\ -\pi + \tan^{-1}\left(\frac{2x}{1-x^2}\right); & \text{if } x < -1 \\ \frac{\pi}{2}; & \text{if } x = 1 \\ -\frac{\pi}{2}; & \text{if } x = -1 \end{cases}$$



**Property (6)**

$$3 \tan^{-1} x = \begin{cases} \tan^{-1} \left( \frac{3x - x^3}{1 - 3x^2} \right); & \text{if } -\frac{1}{\sqrt{3}} < x < \frac{1}{\sqrt{3}} \\ \pi + \tan^{-1} \left( \frac{3x - x^3}{1 - 3x^2} \right); & \text{if } x > \frac{1}{\sqrt{3}} \\ -\pi + \tan^{-1} \left( \frac{3x - x^3}{1 - 3x^2} \right); & \text{if } x < -\frac{1}{\sqrt{3}} \\ \frac{\pi}{2}; & \text{if } x = \frac{1}{\sqrt{3}} \\ -\frac{\pi}{2}; & \text{if } x = -\frac{1}{\sqrt{3}} \end{cases}$$

**Proof (5):** Let  $\tan^{-1} x = \theta$ . Then,  $x = \tan \theta$

$$\therefore \tan 2\theta = \frac{2 \tan \theta}{1 - \tan^2 \theta} \Rightarrow \tan 2\theta = \frac{2x}{1 - x^2}$$

**Case (i):** When  $-1 < x < 1$ :

$$-1 < x < 1 \Rightarrow -1 < \tan \theta < 1$$

$$\Rightarrow -\pi/4 < \theta < \pi/4$$

$$\Rightarrow -\pi/2 < 2\theta < \pi/2 \therefore \tan 2\theta = \frac{2x}{1 - x^2}$$

$$\Rightarrow 2\theta = \tan^{-1} \left( \frac{2x}{1 - x^2} \right) \Rightarrow 2 \tan^{-1} x = \tan^{-1} \left( \frac{2x}{1 - x^2} \right).$$

**Case (ii):** When  $x > 1$ :

$$x > 1 \Rightarrow \tan \theta > 1 \Rightarrow \pi/2 > \theta > \pi/4 \Rightarrow \pi > 2\theta > \pi/2$$

$$\Rightarrow -\pi < -2\theta < -\pi/2 \Rightarrow 0 < \pi - 2\theta < \pi/2$$

$$\Rightarrow -\pi/2 < -\pi + 2\theta < 0 \therefore \tan 2\theta = \frac{2x}{1 - x^2}$$

$$\Rightarrow -\tan(\pi - 2\theta) = \frac{2x}{1 - x^2} \Rightarrow \tan(-\pi + 2\theta) = \frac{2x}{1 - x^2}$$

$$\Rightarrow -\pi + 2\theta = \tan^{-1} \left( \frac{2x}{1 - x^2} \right)$$

$$\Rightarrow 2\theta = \pi + \tan^{-1} \left( \frac{2x}{1 - x^2} \right)$$

$$\Rightarrow 2 \tan^{-1} x = \pi + \tan^{-1} \left( \frac{2x}{1 - x^2} \right)$$

**Case III:** When  $x < -1$ :

$$x < -1 \Rightarrow \tan \theta < -1 \Rightarrow -\pi/2 < \theta < -\pi/4$$

$$\Rightarrow -\pi < 2\theta < -\pi/2 \Rightarrow 0 < \pi + 2\theta < \pi/2$$

$$\therefore \tan 2\theta = \frac{2x}{1 - x^2} \Rightarrow \tan(\pi + 2\theta) = \frac{2x}{1 - x^2}$$

$$\{ \because \tan(\pi + \alpha) = \tan \alpha \}$$

$$\Rightarrow \pi + 2\theta = \tan^{-1} \left( \frac{2x}{1 - x^2} \right)$$

$$\Rightarrow 2\theta = -\pi + \tan^{-1} \left( \frac{2x}{1 - x^2} \right)$$

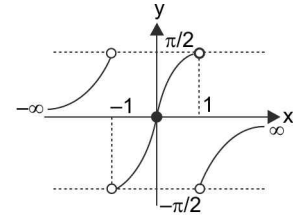

**FIGURE 4.31**

$$\Rightarrow 2 \tan^{-1} x = -\pi + \tan^{-1} \left( \frac{2x}{1 - x^2} \right)$$

Clearly, for  $x = 1$ ;  $2 \tan^{-1} x = 2 \tan^{-1} 1 = \frac{\pi}{2}$

The graph of  $\tan^{-1} \left( \frac{2x}{1 - x^2} \right)$  is as shown in the diagram given above.

**Proof (6):** Let  $\tan^{-1} x = \theta$ . Then  $x = \tan \theta$

$$\therefore \tan 3\theta = \frac{3 \tan \theta - \tan^3 \theta}{1 - 3 \tan^2 \theta} \Rightarrow \tan 3\theta = \frac{3x - x^3}{1 - 3x^2}$$

**Case (i):** When  $-\frac{1}{\sqrt{3}} < x < \frac{1}{\sqrt{3}}$ :

$$-\frac{1}{\sqrt{3}} < x < \frac{1}{\sqrt{3}} \Rightarrow -\frac{1}{\sqrt{3}} < \tan \theta < \frac{1}{\sqrt{3}}$$

$$\Rightarrow -\frac{\pi}{6} < \theta < \frac{\pi}{6} \Rightarrow -\frac{\pi}{2} < 3\theta < \frac{\pi}{2}$$

$$\therefore \tan 3\theta = \frac{3x - x^3}{1 - 3x^2} \Rightarrow 3\theta = \tan^{-1} \left( \frac{3x - x^3}{1 - 3x^2} \right)$$

$$\Rightarrow 3 \tan^{-1} x = \tan^{-1} \left( \frac{3x - x^3}{1 - 3x^2} \right).$$

**Case (ii):** When  $x > \frac{1}{\sqrt{3}}$ :  $x > \frac{1}{\sqrt{3}} \Rightarrow \tan \theta > \frac{1}{\sqrt{3}}$ .

$$\Rightarrow \pi/2 > \theta > \pi/6 \Rightarrow \pi/2 < 3\theta < \frac{3\pi}{2}$$

$$\Rightarrow -\frac{3\pi}{2} < -3\theta < -\frac{\pi}{2} \Rightarrow -\frac{\pi}{2} < \pi - 3\theta < \frac{\pi}{2}$$

$$\Rightarrow -\pi < 3\theta - \pi < \frac{\pi}{2} \therefore \tan 3\theta = \frac{3x - x^3}{1 - 3x^2}$$

$$\Rightarrow -\tan(\pi - 3\theta) = \frac{3x - x^3}{1 - 3x^2} \quad \{\because \tan(\pi - 3\theta) = -\tan 3\theta\}$$

$$\Rightarrow 3\theta - \pi = \tan^{-1}\left(\frac{3x - x^3}{1 - 3x^2}\right)$$

$$\Rightarrow 3 \tan^{-1} x = \pi + \tan^{-1}\left(\frac{3x - x^3}{1 - 3x^2}\right)$$

**Case (iii):** When  $x < -\frac{1}{\sqrt{3}}$ ;  $x < -\frac{1}{\sqrt{3}} \Rightarrow \tan \theta < -\frac{1}{\sqrt{3}}$

$$\Rightarrow -\frac{\pi}{2} < \theta < -\frac{\pi}{6} \Rightarrow -\frac{3\pi}{2} < 3\theta < -\frac{\pi}{2}$$

$$\Rightarrow -\frac{\pi}{2} < \pi + 3\theta < \frac{\pi}{2} \therefore \tan 3\theta = \frac{3x - x^3}{1 - 3x^2}$$

$$\Rightarrow \tan(\pi + 3\theta) = \frac{3x - x^3}{1 - 3x^2} \quad \{\because \tan(\pi + x) = \tan x\}$$

$$\Rightarrow \pi + 3\theta = \tan^{-1}\left(\frac{3x - x^3}{1 - 3x^2}\right)$$

Clearly, for  $x = \frac{1}{\sqrt{3}}$ ;  $3 \tan^{-1} x = 3 \tan^{-1}\left(\frac{1}{\sqrt{3}}\right) = \frac{\pi}{2}$

$$\Rightarrow 3 \tan^{-1} x = -\pi + \tan^{-1}\left(\frac{3x - x^3}{1 - 3x^2}\right)$$

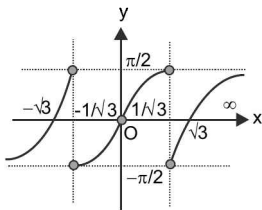

FIGURE 4.32

The graph of  $\tan^{-1}\left(\frac{3x - x^3}{1 - 3x^2}\right)$  is as shown in diagram given above.

**Property (7)**

$$2 \tan^{-1} x = \begin{cases} \sin^{-1}\left(\frac{2x}{1+x^2}\right); & \text{if } -1 \leq x \leq 1 \\ \pi - \sin^{-1}\left(\frac{2x}{1+x^2}\right); & \text{if } x > 1 \\ -\pi - \sin^{-1}\left(\frac{2x}{1+x^2}\right); & \text{if } x < -1 \end{cases}$$

**Property (8)**

$$2 \tan^{-1} x = \begin{cases} \cos^{-1}\left(\frac{1-x^2}{1+x^2}\right); & \text{if } 0 \leq x < \infty \\ -\cos^{-1}\left(\frac{1-x^2}{1+x^2}\right); & \text{if } -\infty < x \leq 0 \end{cases}$$

**Proof (7):** Let,  $\tan^{-1} x = \theta$ , Then  $x = \tan \theta$

$$\therefore \sin 2\theta = \frac{2 \tan \theta}{1 + \tan^2 \theta} \Rightarrow \sin 2\theta = \frac{2x}{1+x^2}$$

**Case (i):** When  $-1 \leq x \leq 1$ ,

$$-1 \leq x \leq 1 \Rightarrow -1 \leq \tan \theta \leq 1$$

$$\Rightarrow -\pi/4 \leq \theta \leq \pi/4$$

$$\Rightarrow -\pi/2 \leq 2\theta \leq \pi/2$$

$$\therefore \sin 2\theta = \frac{2x}{1+x^2}$$

$$\Rightarrow 2\theta = \sin^{-1}\left(\frac{2x}{1+x^2}\right)$$

$$\Rightarrow 2 \tan^{-1} x = \sin^{-1}\left(\frac{2x}{1+x^2}\right)$$

**Case (ii):** When  $x > 1$

$$\therefore x > 1 \Rightarrow \tan \theta > 1$$

$$\Rightarrow \pi/4 < \theta < \pi/2$$

$$\Rightarrow \pi/2 < 2\theta < \pi$$

$$\Rightarrow -\pi < -2\theta < -\pi/2$$

$$\Rightarrow 0 < \pi - 2\theta < \pi/2$$

$$\therefore \sin 2\theta = \frac{2x}{1+x^2} \Rightarrow \sin(\pi - 2\theta) = \frac{2x}{1+x^2}$$

$$\Rightarrow \pi - 2\theta = \sin^{-1}\left(\frac{2x}{1+x^2}\right)$$

$$\Rightarrow \pi - 2 \tan^{-1} x = \sin^{-1}\left(\frac{2x}{1+x^2}\right)$$

$$\Rightarrow 2 \tan^{-1} x = \pi - \sin^{-1}\left(\frac{2x}{1+x^2}\right)$$

**Case (iii):** When  $x < -1 \Rightarrow \tan \theta < -1$

$$\Rightarrow -\pi/2 < \theta < -\pi/4 \Rightarrow -\pi < 2\theta < -\pi/2$$

$$\Rightarrow 0 < \pi + 2\theta < \pi/2 \Rightarrow -\pi/2 < -\pi - 2\theta < 0$$

$$\therefore \sin 2\theta = \frac{2x}{1+x^2} \Rightarrow -\sin(\pi + 2\theta) = \frac{2x}{1+x^2}$$

4.44 ➤ Trigonometry

$$\Rightarrow \sin(-\pi - 2\theta) = \frac{2x}{1+x^2} \Rightarrow -\pi - 2\theta = \sin^{-1}\left(\frac{2x}{1+x^2}\right)$$

$$\Rightarrow -\pi - 2 \tan^{-1} x = \sin^{-1}\left(\frac{2x}{1+x^2}\right)$$

$$\Rightarrow 2 \tan^{-1} x = -\pi - \sin^{-1}\left(\frac{2x}{1+x^2}\right)$$

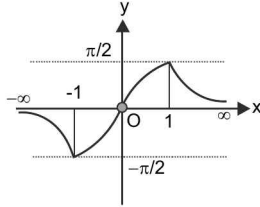

FIGURE 4.33

The graph of  $\sin^{-1}\left(\frac{2x}{1+x^2}\right)$  is as shown in diagram given above.

**Proof (8)** Let  $\tan^{-1} x = \theta$ . Then  $x = \tan \theta$

$$\therefore \cos 2\theta = \frac{1 - \tan^2 \theta}{1 + \tan^2 \theta} \Rightarrow \cos 2\theta = \frac{1 - x^2}{1 + x^2}$$

**Case (i):** When  $0 \leq x < \infty$

$$\Rightarrow 0 \leq \tan \theta < \infty, 0 \leq x < \infty$$

$$\Rightarrow 0 \leq \theta < \pi/2 \Rightarrow 0 \leq 2\theta < \pi$$

$$\therefore \cos 2\theta = \frac{1 - x^2}{1 + x^2}$$

$$\Rightarrow 2\theta = \cos^{-1}\left(\frac{1 - x^2}{1 + x^2}\right)$$

$$\Rightarrow 2 \tan^{-1} x = \cos^{-1}\left(\frac{1 - x^2}{1 + x^2}\right)$$

**case (ii):** When  $-\infty < x \leq 0$

$$\Rightarrow -\infty < \tan \theta \leq 0.$$

$$\Rightarrow -\pi/2 < \theta \leq 0 \Rightarrow 0 \leq -2\theta < \pi$$

$$\therefore \cos 2\theta = \frac{1 - x^2}{1 + x^2} \Rightarrow \cos(-2\theta) = \frac{1 - x^2}{1 + x^2}$$

$$\Rightarrow -2\theta = \cos^{-1}\left(\frac{1 - x^2}{1 + x^2}\right)$$

$$\Rightarrow -2 \tan^{-1} x = \cos^{-1}\left(\frac{1 - x^2}{1 + x^2}\right)$$

$$\Rightarrow 2 \tan^{-1} x = -\cos^{-1}\left(\frac{1 - x^2}{1 + x^2}\right).$$

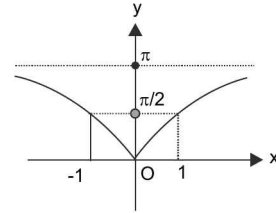

FIGURE 4.34

The graph of  $\cos^{-1}\left(\frac{1 - x^2}{1 + x^2}\right)$  is as shown in diagram given above.

**ILLUSTRATION 37:** Find the subset of domain of function  $f(x) = \sin^{-1}\left(\frac{4x}{x^2+4}\right) + 2 \tan^{-1}\left(-\frac{x}{2}\right)$  in which the function has zero value.

**SOLUTION:**  $f(x) = \sin^{-1}\left(\frac{4x}{x^2+4}\right) - 2 \tan^{-1}\left(\frac{x}{2}\right)$  [ $\because \tan^{-1}(-x) = -\tan^{-1}x$ ]

$$\Rightarrow \frac{4x}{x^2+4} \in [-1, 1] \text{ and } \frac{x}{2} \in \mathbb{R}$$

$$\Rightarrow -1 \leq \frac{4x}{x^2+4} \leq 1$$

$$\Rightarrow -x^2 - 4 \leq 4x \leq x^2 + 4$$

$$\Rightarrow x^2 + 4x + 4 \geq 0 \text{ and } x^2 - 4x + 4 \geq 0$$

$$\Rightarrow (x + 2)^2 \geq 0 \text{ and } (x - 2)^2 \geq 0$$

∴ Domain  $\mathbb{R}$

$$\text{Now } \sin^{-1}\left(\frac{4x}{x^2 + 4}\right) = \sin^{-1}\left[\frac{2\left(\frac{x}{2}\right)}{\left(\frac{x}{2}\right)^2 + 1}\right] \dots\dots\dots(1)$$

and we know that

$$2 \tan^{-1} x = \begin{cases} \sin^{-1}\left(\frac{2x}{1+x^2}\right); & -1 \leq x \leq 1 \\ \pi - \sin^{-1}\left(\frac{2x}{1+x^2}\right); & x > 1 \\ -\pi - \sin^{-1}\left(\frac{2x}{1+x^2}\right); & x < -1 \end{cases}$$

$$\therefore f(x) = \sin^{-1}\left(\frac{4x}{x^2 + 4}\right) - 2 \tan^{-1}\left(\frac{x}{2}\right) = 0$$

$$\text{If } \sin^{-1}\left[\frac{2\left(\frac{x}{2}\right)}{1 + \left(\frac{x}{2}\right)^2}\right] = 2 \tan^{-1}\left(\frac{x}{2}\right)$$

$$\Rightarrow -1 \leq x/2 \leq 1$$

$$\Rightarrow -2 \leq x \leq 2$$

**ILLUSTRATION 38:** Find the interval of  $x$  in which

$$\cos^{-1}\left(\frac{6x}{1+9x^2}\right) = -\frac{\pi}{2} + 2 \tan^{-1}(3x).$$

**SOLUTION:**  $\frac{\pi}{2} - \sin^{-1}\left(\frac{2(3x)}{1+(3x)^2}\right) = -\frac{\pi}{2} + 2 \tan^{-1}(3x)$

$$\Rightarrow 2 \tan^{-1}(3x) = \pi - \sin^{-1}\left(\frac{2(3x)}{1+(3x)^2}\right) \dots\dots(1)$$

$$\therefore 2 \tan^{-1} x = \begin{cases} \sin^{-1}\left(\frac{2x}{1+x^2}\right); & -1 \leq x \leq 1 \\ \pi - \sin^{-1}\left(\frac{2x}{1+x^2}\right); & x > 1 \\ -\pi - \sin^{-1}\left(\frac{2x}{1+x^2}\right); & x < -1 \end{cases}$$

∴ From (1) clearly  $3x > 1$

$$\Rightarrow x > \frac{1}{3} \quad \therefore x \in \left(\frac{1}{3}, \infty\right)$$

**ILLUSTRATION 39:** If  $(x-1)(x^2+1) > 0$ ; then find the value of  $\sin\left(\frac{1}{2}\tan^{-1}\frac{2x}{1-x^2} - \tan^{-1}x\right)$ .

**SOLUTION:**  $(x-1)(x^2+1) > 0$

$$\Rightarrow x > 1$$

$$\sin\left[\frac{1}{2}\tan^{-1}\frac{2x}{1-x^2} - \tan^{-1}x\right] = \sin\left[\frac{1}{2}[-\pi + 2\tan^{-1}x] - \tan^{-1}x\right]$$

$$\left[ \begin{array}{l} \tan^{-1}\left(\frac{2x}{1-x^2}\right) \text{ for } -1 < x < 1 \\ \therefore 2\tan^{-1}x = \begin{cases} \pi + \tan^{-1}\left(\frac{2x}{1-x^2}\right) \text{ for } x > 1 \\ -\pi + \tan^{-1}\left(\frac{2x}{1-x^2}\right) \text{ for } x < -1 \end{cases} \end{array} \right.$$

$$= \sin\left[-\frac{\pi}{2} + \tan^{-1}x - \tan^{-1}x\right] = \sin\left[-\frac{\pi}{2}\right] = -1 \text{ Ans}$$

**ILLUSTRATION 40:** Find the value of  $\cos(2\cos^{-1}x + \sin^{-1}x)$  when  $x = 1/5$ .

**SOLUTION:**  $= \cos\left[2\cos^{-1}\frac{1}{5} + \sin^{-1}\frac{1}{5}\right] = \cos\left[\cos^{-1}\frac{1}{5} + \cos^{-1}\frac{1}{5} + \sin^{-1}\frac{1}{5}\right]$

$$= \cos\left[\cos^{-1}\frac{1}{5} + \frac{\pi}{2}\right] = -\sin\left[\cos^{-1}\frac{1}{5}\right] = -\frac{\sqrt{24}}{5} = \frac{-2\sqrt{6}}{5}$$

**ILLUSTRATION 41:** Solve the equation  $\sin^{-1}(x^2 - 2x + 1) + \cos^{-1}(x^2 - x) = \pi/2$

**SOLUTION:**  $\therefore \sin^{-1}x + \cos^{-1}x = \pi/2 \forall x \in [-1, 1]$

$\therefore x^2 - 2x + 1 = x^2 - x$  and  $x^2 - 2x + 1, x^2 - x$  must belong to  $[-1, 1]$  for some  $x \in \mathbb{R}$

$$\Rightarrow x = 1$$

$$\text{and for } x = 1; x^2 - 2x + 1 = 0 \in [-1, 1]$$

$$\text{and } x^2 - x = 0 \in [-1, 1]$$

$\therefore$  **Ans. 1**

**Aliter:** Let  $x^2 - 2x + 1, x^2 - x \in [-1, 1]$  for some  $x \in \mathbb{R}$ , therefore

$$\sin^{-1}(x^2 - 2x + 1) + \cos^{-1}(x^2 - x) = \pi/2$$

$$\Rightarrow \sin^{-1}(x^2 - 2x + 1) + \frac{\pi}{2} - \sin^{-1}(x^2 - x) = \frac{\pi}{2}$$

$$\Rightarrow \sin^{-1}(x^2 - 2x + 1) = \sin^{-1}(x^2 - x)$$

$\therefore \sin^{-1}x$  is one-one function on  $[-1, 1]$

$$\Rightarrow x^2 - 2x + 1, x^2 - x \in [-1, 1] \text{ and } x^2 - 2x + 1 = x^2 - x.$$

$$\Rightarrow x = 1, \text{ Clearly, for } x = 1, x^2 - 2x + 1 = 0 \text{ and } x^2 - x = 0 \text{ both belong to } [-1, 1]$$

**ILLUSTRATION 42:** Solve  $\sin^{-1}(x^2 - 2x + 3) + \cos^{-1}(x^2 - x) = \pi/2$

**SOLUTION:** We must have  $x^2 - 2x + 3 \in [-1, 1]$  and  $x^2 - x \in [-1, 1]$

$$\text{but } x^2 - 2x + 3 = (x^2 - 2x + 1) + 2 = (x - 1)^2 + 2 \geq 2$$

$$\therefore x^2 - 2x + 3 \notin [-1, 1]$$

$\therefore$  No solution

- ILLUSTRATION 43:** (a) If  $\sin^{-1}x + \sin^{-1}y = \frac{2\pi}{3}$ , then evaluate  $\cos^{-1}x + \cos^{-1}y$ .  
 (b) If  $x \geq 0$  and  $\theta = \sin^{-1}x + \cos^{-1}x - \tan^{-1}x$ , then find the range of  $\theta$ .  
 (c) Find the number of solutions of equation  $\sin^{-1}x - \cos^{-1}x = \cos^{-1}\left(\frac{\sqrt{3}}{2}\right)$ .  
 (d) Find the value of  $x$  if  $\sin^{-1}x + \cot^{-1}\left(\frac{1}{2}\right) = \frac{\pi}{2}$ .  
 (e) Solve the equation  $\sin^{-1}\left(\tan\frac{\pi}{4}\right) - \sin^{-1}\sqrt{\frac{3}{x}} - \frac{\pi}{6} = 0$ .

**SOLUTION:** (a)  $\sin^{-1}x + \sin^{-1}y = \frac{\pi}{2} - \cos^{-1}x + \frac{\pi}{2} - \cos^{-1}y = \frac{2\pi}{3}$   
 $\Rightarrow \cos^{-1}x + \cos^{-1}y = \pi - \frac{2\pi}{3} = \frac{\pi}{3}$ .

**Ans.  $\pi/3$**

- (b)  $\theta = \sin^{-1}x + \cos^{-1}x - \tan^{-1}x$  is defined for  $x \in [0,1]$  as  $x \geq 0$

$$\therefore \theta = \frac{\pi}{2} - \tan^{-1}x$$

$$\because x \in [0,1]$$

$$\Rightarrow \tan^{-1}x \in \left[0, \frac{\pi}{4}\right]$$

$$\therefore -\tan^{-1}x \in [-\pi/4, 0]$$

$$\therefore \frac{\pi}{2} - \tan^{-1}x \in \left[\frac{\pi}{4}, \frac{\pi}{2}\right]$$

(c)  $\sin^{-1}x - \cos^{-1}x = \cos^{-1}\frac{\sqrt{3}}{2}$

$$\Rightarrow \sin^{-1}x - \cos^{-1}x = \frac{\pi}{6}. \text{ Also } \sin^{-1}x + \cos^{-1}x = \frac{\pi}{2}$$

$$\Rightarrow 2\sin^{-1}x = \frac{2\pi}{3} \Rightarrow \sin^{-1}x = \frac{\pi}{3} \Rightarrow x = \frac{\sqrt{3}}{2}$$

$\therefore$  There will be a unique solution.

(d)  $\sin^{-1}x + \cot^{-1}\frac{1}{2} = \frac{\pi}{2}$

$$\Rightarrow \sin^{-1}x + \cos^{-1}\left(\frac{1}{\sqrt{5}}\right) = \frac{\pi}{2}. \text{ Also } \sin^{-1}x + \cos^{-1}x = \frac{\pi}{2} \Rightarrow x = \frac{1}{\sqrt{5}}$$

(e)  $\sin^{-1}\left(\tan\frac{\pi}{4}\right) - \sin^{-1}\sqrt{\frac{3}{x}} - \frac{\pi}{6} = 0$

$$\sin^{-1}1 - \sin^{-1}\sqrt{\frac{3}{x}} - \frac{\pi}{6} = 0 \Rightarrow \frac{\pi}{2} - \sin^{-1}\sqrt{\frac{3}{x}} - \frac{\pi}{6} = 0 \Rightarrow \frac{\pi}{3} = \sin^{-1}\sqrt{\frac{3}{x}}$$

$$\Rightarrow x = 4$$

**TEXTUAL EXERCISE-4 (SUBJECTIVE)**

- Solve the equation  $\cot^{-1}x + \tan^{-1}3 = \pi/2$
- Solve for  $x$ , if  $\sin^{-1} \frac{2a}{1+a^2} + \sin^{-1} \frac{2b}{1+b^2} = 2\tan^{-1}x$ ;  
where  $a, b \in (-1, 1)$
- Evaluate  $\sin \left[ \cot^{-1} \frac{1-x^2}{2x} + \cos^{-1} \frac{1-x^2}{1+x^2} \right]$  for  $x > 0$ .
- Evaluate  $\tan \left( \frac{1}{2} \sin^{-1} \frac{2x}{1+x^2} + \frac{1}{2} \cos^{-1} \frac{1-x^2}{1+x^2} \right)$ .  
if  $x \in [0, 1]$
- Solve for  $x$ , if  $a$  and  $b \in (0, \infty)$   
 $\cos^{-1} \left( \frac{1-a^2}{1+a^2} \right) - \cos^{-1} \left( \frac{1-b^2}{1+b^2} \right) = 2 \tan^{-1}x$ ,
- Solve the following equations:  
 $\cos^{-1} \left( \frac{x^2-1}{x^2+1} \right) + \tan^{-1} \left( \frac{2x}{x^2-1} \right) = \frac{2\pi}{3}$
- Find  $x$  if
  - $4 \sin^{-1}x + \cos^{-1}x = \frac{3\pi}{4}$
  - $5 \tan^{-1}x + 3 \cot^{-1}x = \frac{7\pi}{4}$
- Prove the following
  - $\sin \left( 2 \sin^{-1} \frac{3}{5} \right) = \frac{24}{25}$
  - $\cos(2 \tan^{-1}2) + \sin(2 \tan^{-1}3) = 0$
- If  $2 \tan^{-1}x + \sin^{-1} \frac{2x}{1+x^2}$  is independent of  $x$ , then find the possible range of values of  $x$ .
- Solve the inequality
  - $\left| \frac{\pi}{2} - \sin^{-1} \left( \frac{1-x^2}{1+x^2} \right) \right| < \pi/3$
  - $\sin^{-1} \left\{ \sin \left[ \frac{2x^2+4}{1+x^2} \right] \right\} < \pi-3$ .
- Show that  
 $2 \tan^{-1} \left\{ \tan \frac{\alpha}{2} \tan \left( \frac{\pi}{4} - \frac{\beta}{2} \right) \right\} = \tan^{-1} \frac{\sin \alpha \cos \beta}{\cos \alpha + \sin \beta}$   
where  $\alpha, \beta \in (0, \pi/2)$ .
- Solve  $3 \sin^{-1} \frac{2x}{1+x^2} - 4 \cos^{-1} \frac{1-x^2}{1+x^2} + 2 \tan^{-1} \frac{2x}{1-x^2} = \frac{\pi}{3}$
- Find the range of  $(\tan^{-1}x)^3 + (\cot^{-1}x)^3$ .
- Find the range of  $(\sin^{-1}x)^2 + (\cos^{-1}x)^2$ .
- Consider the equation  $(\sin^{-1}x)^3 + (\cos^{-1}x)^3 = a\pi^3$ . Find the values of parameter  $a$  so that the given equation has a solution.
- Solve for  $x$ ,  $(\tan^{-1}x)^2 + (\cot^{-1}x)^2 = \frac{5\pi^2}{8}$ .
- Find the positive integral ordered pair  $(x, y)$  satisfying the equation  
 $\sin^{-1} \left( \frac{x}{\sqrt{1+x^2}} \right) + \cos^{-1} \left( \frac{y}{\sqrt{1+y^2}} \right) = \tan^{-1}(3)$
- Prove that
  - $\cos^{-1} \frac{\cos x + \cos y}{1 + \cos x \cos y} = 2 \tan^{-1} \left( \tan \frac{x}{2} \cdot \tan \frac{y}{2} \right)$
  - $2 \tan^{-1} \left[ \sqrt{\frac{a-b}{a+b}} \cdot \tan \frac{x}{2} \right] = \cos^{-1} \left[ \frac{b+a \cos x}{a+b \cos x} \right]$

**Answer Keys**

- $x = 3$
- $x = \frac{a+b}{1-ab}$
- 1
- $\frac{2x}{1-x^2}$
- $\frac{a-b}{1+ab}$
- $x = \sqrt{3}, \tan \pi/12$
- (a)  $\frac{\sqrt{3}-1}{2\sqrt{2}}$  (b)  $\sqrt{2}-1$
- $x \in (-\infty, -1) \cup (1, \infty)$
- (a)  $x \in \left( -\frac{1}{\sqrt{3}}, \frac{1}{\sqrt{3}} \right)$  (b)  $x \in (-1, 1)$
- $x = -\tan \frac{13\pi}{18}, \frac{1}{\sqrt{3}}, \tan \frac{11\pi}{30}$
- $\left[ \frac{\pi^3}{32}, \frac{7\pi^3}{8} \right]$
- $\left[ \frac{\pi^2}{8}, \frac{5\pi^2}{4} \right]$
- $[1/32, 7/8]$
- $x = -1$
- $(4, -13); (13, 4); (-7, -2); (2, -7); (5, -8); (8, -5); (1, 1); (-2, 1)$

**TEXTUAL EXERCISE-4 (OBJECTIVE)**

1. If  $x \in [-1, 0)$ , then  $\cos^{-1}(2x^2 - 1) - 2\sin^{-1}x$  equals to
- (a)  $-\frac{\pi}{2}$  (b)  $\pi$   
 (c)  $\frac{3\pi}{2}$  (d)  $-2\pi$
2. The solution of the inequality  $\log_{1/2} \sin^{-1} x > \log_{1/2} \cos^{-1} x$  is
- (a)  $x \in \left[0, \frac{1}{\sqrt{2}}\right]$  (b)  $x \in \left(\frac{1}{\sqrt{2}}, 1\right]$   
 (c)  $x \in \left(0, \frac{1}{\sqrt{2}}\right)$  (d) None of these
3. If  $\tan^{-1}(\sqrt{\cos \alpha + 1}) + \cot^{-1}(\sqrt{\cos \alpha + 1}) = \mu$  (where  $\alpha \neq n\pi + \frac{\pi}{2}, n \in \mathbb{Z}$ ), then  $\sin \mu$  is equal to
- (a)  $\tan^2 \alpha$  (b)  $\tan 2\alpha$   
 (c)  $\sec^2 \alpha - \tan^2 \alpha$  (d)  $\cos^2 \frac{\alpha}{2}$
4.  $\sin^{-1}(\cos(\sin^{-1}x)) + \cos^{-1}(\sin(\cos^{-1}x))$  equals
- (a) 0 (b)  $\pi/2$   
 (c)  $\pi$  (d)  $\pi/4$
5. If  $\sin^{-1}x + \sin^{-1}2x = \pi/3$ , then  $x$  equals
- (a)  $\frac{1}{2}\sqrt{\frac{3}{7}}$  (b)  $\sqrt{\frac{3}{2}}$   
 (c)  $\sqrt{\frac{3}{7}}$  (d)  $-\frac{1}{2}\sqrt{\frac{3}{7}}$
6. If  $\sin^{-1} \frac{x}{5} + \operatorname{cosec}^{-1} \frac{5}{4} = \frac{\pi}{2}$ , then  $x$  is equal to
- (a) 4 (b) 5  
 (c) 1 (d) 3
7. If  $\sin^{-1}x + \sin^{-1}(1-x) = \cos^{-1}x$ , then  $x$  is equal to
- (a) 1, -1 (b) 1, 0  
 (c) 0,  $\frac{1}{2}$  (d) None of these
8. The value of  $\sin\left(2\tan^{-1}\frac{1}{3}\right) + \cos \tan^{-1}(2\sqrt{2})$  is
- (a)  $\frac{14}{15}$  (b)  $\frac{1}{15}$   
 (c)  $\frac{13}{15}$  (d) None of these
9. If  $x > 1$ , then  $2\tan^{-1}x - \tan^{-1}\left(\frac{2x}{1-x^2}\right)$  is equal to
- (a) 0 (b)  $\pi$   
 (c)  $\frac{\pi}{2}$  (d) None of these
10. If  $x > 1$ , then the value of  $2\tan^{-1}x + \sin^{-1}\left(\frac{2x}{1+x^2}\right)$  is
- (a)  $-\pi$  (b)  $\frac{\pi}{2}$   
 (c)  $\pi$  (d) None of these
11. If  $\sin^{-1}a + \sin^{-1}b = \frac{\pi}{2}$ , then
- (a)  $\sin^{-1}a = \sin^{-1}b$   
 (b)  $\sin^{-1}a = \cos^{-1}b$   
 (c)  $\cos^{-1}a = \sin^{-1}b$   
 (d)  $\cos^{-1}a = \cos^{-1}b$
12. If  $\sin^{-1}x = \frac{\pi}{5}$  for some  $x \in (-1, 1)$ , then the value of  $\cos^{-1}x$  is
- (a)  $\frac{3\pi}{10}$  (b)  $\frac{5\pi}{10}$   
 (c)  $\frac{7\pi}{10}$  (d)  $\frac{9\pi}{10}$
13. If  $\sin^{-1}x + \sin^{-1}y = \frac{2\pi}{3}$ , then  $\cos^{-1}x + \cos^{-1}y =$
- (a)  $\frac{2\pi}{3}$  (b)  $\frac{\pi}{3}$   
 (c)  $\frac{\pi}{6}$  (d)  $\pi$
14.  $\sin^{-1}\frac{4}{5} + 2\tan^{-1}\frac{1}{3}$  is equal to
- (a)  $\frac{\pi}{2}$  (b)  $\frac{\pi}{3}$   
 (c)  $\frac{\pi}{4}$  (d) None of these



4.50 > Trigonometry

15.  $\sin^{-1}\left(a - \frac{a^2}{3} + \frac{a^3}{9} - \dots\right) + \cos^{-1}(1 + b + b^2 + \dots) = \pi/2$

when

- (a)  $a = -3$  and  $b = 1$
- (b)  $a = 1$  and  $b = -1/3$
- (c)  $a = \frac{1}{6}$  and  $b = \frac{1}{2}$
- (d) None of these

16. The set of the values of  $x$  satisfying  $2 \cos^{-1} x = \sin^{-1}(2x\sqrt{1-x^2})$  is

(a)  $[0, 1]$  (b)  $\left[\frac{1}{\sqrt{2}}, 1\right]$

(c)  $\left[0, \frac{1}{\sqrt{2}}\right]$  (d)  $[-1, 1]$

17. If  $\alpha \leq \sin^{-1} x + \cos^{-1} x + \tan^{-1} x \leq \beta$ , then

(a)  $\alpha = 0, \beta = \pi$  (b)  $\alpha = 0, \beta = \frac{\pi}{2}$

(c)  $\alpha = \frac{\pi}{4}, \beta = \frac{3\pi}{4}$  (d) None of these

Answer Keys

1. (b)    2. (c)    3. (c)    4. (b)    5. (a)    6. (d)    7. (c)    8. (a)    9. (b)    10. (c)  
 11. (b, c)    12. (a)    13. (b)    14. (a)    15. (b)    16. (b)    17. (c)

AND DIFFERENCE OF INVERSE TRIGONOMETRIC FUNCTIONS

Property (1)

$$\sin^{-1} x + \sin^{-1} y = \begin{cases} \sin^{-1}\{x\sqrt{1-y^2} + y\sqrt{1-x^2}\}, & \text{if } x^2 + y^2 \leq 1 \\ & \text{or if } xy < 0 \text{ and } x^2 + y^2 > 1; \text{ where } x, y \in [-1, 1] \\ \pi - \sin^{-1}\{x\sqrt{1-y^2} + y\sqrt{1-x^2}\}, & \text{if } 0 < x, y \leq 1 \text{ and } x^2 + y^2 > 1 \\ -\pi - \sin^{-1}\{x\sqrt{1-y^2} + y\sqrt{1-x^2}\}, & \text{if } -1 \leq x, y < 0 \text{ and } x^2 + y^2 > 1 \end{cases}$$

**Proof 1:** Let,  $\sin^{-1} x = A$  and  $\sin^{-1} y = B$ . Then,

$x = \sin A, y = \sin B$  and  $A, B \in [-\pi/2, \pi/2]$   
 $\Rightarrow \cos A = \sqrt{1-x^2}, \cos B = \sqrt{1-y^2},$   
 $\{\because A, B \in [-\pi/2, \pi/2] \therefore \cos A, \cos B \geq 0\}$   
 $\therefore \sin(A+B) = \sin A \cos B + \cos A \sin B$   
 $\Rightarrow \sin(A+B) = x\sqrt{1-y^2} + y\sqrt{1-x^2}$  ..... (i)  
 $\sin(A-B) = x\sqrt{1-y^2} - y\sqrt{1-x^2}$  ..... (ii)  
 $\cos(A+B) = \sqrt{1-x^2} \sqrt{1-y^2} - xy$  ..... (iii)  
 $\cos(A-B) = \sqrt{1-x^2} \sqrt{1-y^2} + xy$  ..... (iv)

$\Rightarrow 1-x^2 \geq y^2$  and  $1-y^2 \geq x^2$   
 $\Rightarrow (1-x^2)(1-y^2) \geq x^2 y^2$   
 $\Rightarrow \sqrt{1-x^2} \sqrt{1-y^2} \geq |xy|$   
 $\Rightarrow \sqrt{1-x^2} \sqrt{1-y^2} - xy \geq 0$   
 $\Rightarrow \cos(A+B) \geq 0$  {Using (iii)}  
 $\Rightarrow A+B$  lies either in I quadrant or in IV quadrant.  
 $\Rightarrow A+B \in [-\pi/2, \pi/2]$   
 $\{\because A, B \in [-\pi/2, \pi/2]\}$   
 $\Rightarrow A+B \in [-\pi, \pi]$   
 $\Rightarrow -\pi \leq A+B \leq \pi$ .  
 $\therefore \sin(A+B) = x\sqrt{1-y^2} + y\sqrt{1-x^2}$  {from (i)}

**Case I:** When  $-1 \leq x, y \leq 1$  and  $x^2 + y^2 \leq 1$ .

In this case, we have  $x^2 + y^2 \leq 1$

$$\Rightarrow A + B = \sin^{-1} \left\{ x\sqrt{1-y^2} + y\sqrt{1-x^2} \right\}$$

$$\left\{ \because -\frac{\pi}{2} \leq A + B \leq \frac{\pi}{2} \right\}$$

$$\Rightarrow \sin^{-1} x + \sin^{-1} y = \sin^{-1} \left\{ x\sqrt{1-y^2} + y\sqrt{1-x^2} \right\}.$$

**Case II:** When  $xy < 0$  and  $x^2 + y^2 > 1$

In this case, we have,  $xy < 0$

$$\Rightarrow (x > 0 \text{ and } y < 0) \text{ or } (x < 0 \text{ and } y > 0)$$

$$\Rightarrow \{A \in (0, \pi/2] \text{ and } B \in [-\pi/2, 0)\}$$

or  $\{A \in [-\pi/2, 0) \text{ and } B \in (0, \pi/2]\}$

$$\Rightarrow -\frac{\pi}{2} \leq A + B \leq \frac{\pi}{2} \quad \dots \text{(iv)}$$

and  $x^2 + y^2 > 1 \Rightarrow 1 - x^2 < y^2$  and  $1 - y^2 < x^2$ .

$$\Rightarrow (1 - x^2)(1 - y^2) < x^2 y^2 \quad \{\because xy < 0\}$$

$$\Rightarrow \left( \sqrt{1-x^2} \sqrt{1-y^2} \right) < (|xy|)^2$$

$$\Rightarrow -|xy| < \sqrt{1-x^2} \sqrt{1-y^2} < |xy|$$

$$\Rightarrow xy < \sqrt{1-x^2} \cdot \sqrt{1-y^2} < -xy \quad \left\{ \begin{array}{l} \because xy < 0 \\ \because |xy| = -xy \end{array} \right\}$$

$$\Rightarrow \sqrt{1-x^2} \cdot \sqrt{1-y^2} - xy > 0 \Rightarrow \cos(A + B) > 0$$

{using (ii)}

$$\Rightarrow A + B \text{ lies either in I quadrant or in IV quadrant.}$$

$$\Rightarrow A + B \in [-\pi/2, \pi/2]$$

$$\therefore \sin(A + B) = x\sqrt{1-y^2} + y\sqrt{1-x^2}$$

$$\Rightarrow A + B = \sin^{-1} \left\{ x\sqrt{1-y^2} + y\sqrt{1-x^2} \right\}$$

{ $\because A + B \in [-\pi/2, \pi/2]$ }

$$\Rightarrow \sin^{-1} x + \sin^{-1} y = \sin^{-1} \left\{ x\sqrt{1-y^2} + y\sqrt{1-x^2} \right\}$$

**Case III:** When  $x^2 + y^2 > 1$ ,  $0 < x, y \leq 1$

In this case, we have,  $0 < x, y \leq 1$

$$\Rightarrow A \in [0, \pi/2] \text{ and } B \in [0, \pi/2]$$

$$\Rightarrow A + B \in [0, \pi]$$

and  $x^2 + y^2 > 1 \Rightarrow 1 - x^2 < y^2$  and  $1 - y^2 < x^2$ .

$$\Rightarrow (1 - x^2)(1 - y^2) < x^2 y^2$$

$$\Rightarrow \sqrt{1-x^2} \cdot \sqrt{1-y^2} < xy \quad \{\because xy > 0\}$$

$$\Rightarrow \sqrt{1-x^2} \cdot \sqrt{1-y^2} - xy < 0$$

$$\Rightarrow \cos(A + B) < 0 \quad \{\text{Using (iii)}\}$$

$$\Rightarrow (A + B) \text{ lies either in II quadrant or in III quadrant}$$

$$\Rightarrow \frac{\pi}{2} < A + B \leq \pi \quad \{\because A + B \in [0, \pi]\}$$

$$\Rightarrow -\pi \leq -(A + B) < -\pi/2 \Rightarrow 0 \leq \pi - (A + B) < \pi/2$$

$$\therefore \sin(A + B) = x\sqrt{1-y^2} + y\sqrt{1-x^2} \quad \{\text{from (i)}\}$$

$$\Rightarrow \sin\{\pi - (A + B)\} = x\sqrt{1-y^2} + y\sqrt{1-x^2}$$

( $\because \sin(\pi - \theta) = \sin \theta$ )

$$\Rightarrow \pi - (A + B) = \sin^{-1} \left\{ x\sqrt{1-y^2} + y\sqrt{1-x^2} \right\}$$

$$\Rightarrow A + B = \pi - \sin^{-1} \left\{ x\sqrt{1-y^2} + y\sqrt{1-x^2} \right\}$$

$$\Rightarrow \sin^{-1} x + \sin^{-1} y = \pi - \sin^{-1} \left\{ x\sqrt{1-y^2} + y\sqrt{1-x^2} \right\}$$

**Case IV:** When  $-1 \leq x, y < 0$  and  $x^2 + y^2 > 1$

In this case, we have  $-1 \leq x, y < 0$

$$\Rightarrow A \in [-\pi/2, 0) \text{ and } B \in [-\pi/2, 0)$$

$$\Rightarrow A + B \in [-\pi, 0)$$

and  $x^2 + y^2 > 1 \Rightarrow 1 - x^2 < y^2$  and  $1 - y^2 < x^2$

$$\Rightarrow (1 - x^2)(1 - y^2) < x^2 y^2$$

$$\Rightarrow \sqrt{1-x^2} \cdot \sqrt{1-y^2} < xy \quad \{\because xy > 0\}$$

$$\Rightarrow \sqrt{1-x^2} \cdot \sqrt{1-y^2} - xy < 0$$

$$\Rightarrow \cos(A + B) < 0 \quad \{\text{using (iii)}\}$$

$$\Rightarrow A + B \text{ lies either in II quadrant or in III quadrant.}$$

$$\Rightarrow -\pi \leq A + B < -\pi/2$$

$$\Rightarrow \pi/2 \leq -(A + B) \leq \pi$$

$$\Rightarrow -\pi/2 \leq -\pi - (A + B) \leq 0$$

$$\Rightarrow \sin(A + B) = x\sqrt{1-y^2} + y\sqrt{1-x^2}$$

$$\Rightarrow -\sin\{\pi + (A + B)\} = x\sqrt{1-y^2} + y\sqrt{1-x^2}$$

$$\Rightarrow \sin\{-\pi - (A + B)\} = x\sqrt{1-y^2} + y\sqrt{1-x^2}$$

$$\Rightarrow -\pi - (A + B) = \sin^{-1} \left\{ x\sqrt{1-y^2} + y\sqrt{1-x^2} \right\}$$

$$\left[ \because -\frac{\pi}{2} \leq -\pi - (A + B) \leq 0 \right]$$

$$\Rightarrow A + B = -\pi - \sin^{-1} \left\{ x\sqrt{1-y^2} + y\sqrt{1-x^2} \right\}$$

$$\Rightarrow \sin^{-1} x + \sin^{-1} y = -\pi - \sin^{-1} \left\{ x\sqrt{1-y^2} + y\sqrt{1-x^2} \right\}$$

**ILLUSTRATION 44:** Prove that  $\sin^{-1} \frac{3}{\sqrt{11}} + \sin^{-1} \frac{1}{\sqrt{99}} + \sin^{-1} \frac{1}{3} = \sec^{-1} \sqrt{99} + \operatorname{cosec}^{-1} \sqrt{99}$

**SOLUTION:**  $L.H.S = \sin^{-1} \frac{3}{\sqrt{11}} + \sin^{-1} \frac{1}{\sqrt{99}} + \sin^{-1} \frac{1}{3} = \tan^{-1} \frac{3}{\sqrt{2}} + \tan^{-1} \frac{1}{7\sqrt{2}} + \tan^{-1} \frac{1}{2\sqrt{2}}$

$$\tan^{-1} \left( \frac{\frac{3}{\sqrt{2}} + \frac{1}{7\sqrt{2}}}{1 - \frac{3}{\sqrt{2}} \times \frac{1}{7\sqrt{2}}} \right) + \tan^{-1} \left( \frac{1}{2\sqrt{2}} \right) = \tan^{-1} \left[ \frac{21\sqrt{2} + \sqrt{2}}{11} \right] + \tan^{-1} \left( \frac{1}{2\sqrt{2}} \right)$$

$$= \tan^{-1} (2\sqrt{2}) + \tan^{-1} \left( \frac{1}{2\sqrt{2}} \right) \left[ \because \tan^{-1} \frac{1}{x} = \cot^{-1} x \text{ for } x > 0 \right] = \tan^{-1} (2\sqrt{2}) + \cot^{-1} (2\sqrt{2}) = \frac{\pi}{2}$$

Also R.H.S. =  $\sec^{-1} \sqrt{99} + \operatorname{cosec}^{-1} \sqrt{99} = \frac{\pi}{2} \therefore L.H.S. = R.H.S.$

**ILLUSTRATION 45:** Show that

(i)  $\sin^{-1} \frac{4}{5} + \sin^{-1} \frac{13}{15} = \pi - \sin^{-1} \left( \frac{8\sqrt{14} + 39}{75} \right)$

(ii)  $\sin^{-1} \frac{4}{5} + \sin^{-1} \frac{5}{13} = \cos^{-1} \frac{16}{65}$

**SOLUTION:** (i)  $\left(\frac{4}{5}\right) > 0; \frac{13}{15} > 0$  and  $\left(\frac{4}{5}\right)^2 + \left(\frac{13}{15}\right)^2 = \frac{16}{25} + \frac{169}{225} = \frac{144 + 169}{225} = \frac{313}{225} > 1$  we know that

$$\sin^{-1} x + \sin^{-1} y = \pi - \sin^{-1} \left[ x\sqrt{1-y^2} + y\sqrt{1-x^2} \right] \text{ for } x^2 + y^2 > 1 \text{ and } 0 < x, y \leq 1$$

$$\therefore \sin^{-1} \left( \frac{4}{5} \right) + \sin^{-1} \left( \frac{13}{15} \right) = \pi - \sin^{-1} \left[ \left( \frac{4}{5} \right) \sqrt{1 - \frac{169}{225}} + \frac{13}{15} \sqrt{1 - \frac{16}{25}} \right]$$

$$= \pi - \sin^{-1} \left[ \frac{4}{5} \times \frac{\sqrt{56}}{15} + \frac{13}{15} \times \frac{3}{5} \right] = \pi - \sin^{-1} \left[ \frac{8}{75} \sqrt{14} + \frac{39}{75} \right] = \pi - \sin^{-1} \left[ \frac{8\sqrt{14} + 39}{75} \right]$$

(ii)  $\frac{4}{5} > 0; \frac{5}{13} > 0$  and  $\left(\frac{4}{5}\right)^2 + \left(\frac{5}{13}\right)^2 = \frac{16}{25} + \frac{25}{169} = \frac{3329}{4225} < 1$

and we know that

$$\sin^{-1} x + \sin^{-1} y = \sin^{-1} \left[ x\sqrt{1-y^2} + y\sqrt{1-x^2} \right] \text{ for } x^2 + y^2 \leq 1 \text{ and for } x^2 + y^2 > 1 \text{ and } xy < 0$$

$$\therefore \sin^{-1} \frac{4}{5} + \sin^{-1} \frac{5}{13} = \sin^{-1} \left[ \frac{4}{5} \sqrt{1 - \frac{25}{169}} + \frac{5}{13} \sqrt{1 - \frac{16}{25}} \right] = \sin^{-1} \left[ \frac{4}{5} \times \frac{12}{13} + \frac{5}{13} \times \frac{3}{5} \right]$$

$$= \sin^{-1} \left[ \frac{48}{65} + \frac{15}{65} \right] = \sin^{-1} \left[ \frac{63}{65} \right]$$

$$= \cos^{-1} \sqrt{1 - \left( \frac{63}{65} \right)^2} = \cos^{-1} \sqrt{\frac{(65)^2 - (63)^2}{(65)^2}} = \cos^{-1} \sqrt{\frac{256}{(65)^2}} = \cos^{-1} \frac{16}{65}$$

= R.H.S hence proved

**Property (2)**

$$\sin^{-1} x - \sin^{-1} y = \begin{cases} \sin^{-1} \{x\sqrt{1-y^2} - y\sqrt{1-x^2}\}, & \text{if } x^2 + y^2 \leq 1 \\ \pi - \sin^{-1} \{x\sqrt{1-y^2} - y\sqrt{1-x^2}\}, & \text{if } 0 < x \leq 1, -1 \leq y \leq 0 \text{ and } x^2 + y^2 > 1 \\ -\pi - \sin^{-1} \{x\sqrt{1-y^2} - y\sqrt{1-x^2}\}, & \text{if } -1 \leq x < 0, 0 < y \leq 1 \text{ and } x^2 + y^2 > 1 \end{cases}$$

**Proof 2:** Left for students as an exercise.

**Property (3)**

$$\cos^{-1} x + \cos^{-1} y = \begin{cases} \cos^{-1} \{xy - \sqrt{1-x^2} \sqrt{1-y^2}\}, & \text{if } -1 \leq x, y \leq 1 \text{ and } x + y \geq 0 \\ 2\pi - \cos^{-1} \{xy - \sqrt{1-x^2} \sqrt{1-y^2}\}, & \text{if } -1 \leq x, y \leq 1 \text{ and } x + y < 0 \end{cases}$$

**Property (4)**

$$\cos^{-1} x - \cos^{-1} y = \begin{cases} \cos^{-1} \{xy + \sqrt{1-x^2} \sqrt{1-y^2}\}, & \text{if } -1 \leq x, y \leq 1 \text{ and } x \leq y \\ -\cos^{-1} \{xy + \sqrt{1-x^2} \sqrt{1-y^2}\}, & \text{if } -1 \leq x, y \leq 1 \text{ and } x \geq y. \end{cases}$$

**Proof 3:** Let  $\cos^{-1} x = A$  and  $\cos^{-1} y = B$ . Then,

$$x = \cos A, y = \cos B \text{ and } A, B \in [0, \pi]$$

$$\Rightarrow \sin A = \sqrt{1-x^2} \text{ and } \sin B = \sqrt{1-y^2} \\ \{\because \sin A, \sin B \geq 0 \text{ for } A, B \in [0, \pi]\}$$

$$\therefore \cos(A+B) = xy - \sqrt{1-x^2} \sqrt{1-y^2} \quad \dots (i)$$

$$\cos(A-B) = xy + \sqrt{1-x^2} \sqrt{1-y^2} \quad \dots (ii)$$

**Case I:** When  $-1 \leq x, y \leq 1$  and  $x + y \geq 0$ ;

In this case,  $-1 \leq x, y \leq 1 \Rightarrow A, B \in [0, \pi]$

$$\Rightarrow 0 \leq A+B \leq 2\pi \quad \dots (iii)$$

$$\text{and } x+y \geq 0 \Rightarrow \cos A + \cos B \geq 0$$

$$\Rightarrow \cos A \geq -\cos B \Rightarrow \cos A \geq \cos(\pi - B)$$

$$\Rightarrow A \leq \pi - B \quad \{\because \cos \theta \text{ is decreasing on } [0, \pi]\}$$

$$\Rightarrow A+B \leq \pi \quad \dots (iv)$$

from (iii) and (iv), we get  $0 \leq A+B \leq \pi$

$$\therefore \cos(A+B) = xy - \sqrt{1-x^2} \sqrt{1-y^2}$$

$$\Rightarrow A+B = \cos^{-1} \{xy - \sqrt{1-x^2} \sqrt{1-y^2}\}$$

$$\Rightarrow \cos^{-1} x + \cos^{-1} y = \cos^{-1} \{xy - \sqrt{1-x^2} \sqrt{1-y^2}\}$$

**Case II:** When  $-1 \leq x, y \leq 1$  and  $x + y < 0$ ;

In this case:

$$\Rightarrow -1 \leq x, y \leq 1 \Rightarrow A, B \in [0, \pi] \text{ and } 0 \leq A+B \leq 2\pi$$

$$\Rightarrow x+y < 0 \Rightarrow \cos A + \cos B \leq 0 \quad \dots (v)$$

$$\Rightarrow \cos A \leq -\cos B \Rightarrow \cos A \leq \cos(\pi - B)$$

$$\Rightarrow A \geq \pi - B \quad \{\because \cos x \text{ is decreasing on } [0, \pi]\}$$

$$\Rightarrow A+B \geq \pi \quad \dots (vi)$$

from (v) and (vi), we get  $\pi \leq A+B \leq 2\pi$

$$\Rightarrow -\pi \geq -(A+B) \geq -2\pi \Rightarrow \pi \geq 2\pi - (A+B) \geq 0$$

$$\Rightarrow 0 \leq 2\pi - (A+B) \leq \pi \therefore \cos(A+B) = xy - \sqrt{1-x^2} \sqrt{1-y^2}$$

$$\Rightarrow \cos\{2\pi - (A+B)\} = xy - \sqrt{1-x^2} \sqrt{1-y^2}$$

$$\Rightarrow 2\pi - (A+B) = \cos^{-1} \{xy - \sqrt{1-x^2} \sqrt{1-y^2}\}$$

$$\Rightarrow A+B = 2\pi - \cos^{-1} \{xy - \sqrt{1-x^2} \sqrt{1-y^2}\}$$

$$\Rightarrow \cos^{-1} x + \cos^{-1} y =$$

$$2\pi - \cos^{-1} \{xy - \sqrt{1-x^2} \sqrt{1-y^2}\}$$

**Proof 4:** Left for students as an exercise

**Property (5)**

$$\tan^{-1} x + \tan^{-1} y$$

$$= \begin{cases} \tan^{-1} \left( \frac{x+y}{1-xy} \right), & \text{if } xy < 1 \\ \pi + \tan^{-1} \left( \frac{x+y}{1-xy} \right), & \text{if } x > 0, y > 0 \text{ and } xy > 1 \\ -\pi + \tan^{-1} \left( \frac{x+y}{1-xy} \right), & \text{if } x < 0, y < 0 \text{ and } xy > 1 \\ \frac{\pi}{2} & \text{for } x > 0, y > 0 \text{ and } xy = 1 \\ -\frac{\pi}{2} & \text{for } x < 0, y < 0 \text{ and } xy = 1 \end{cases}$$

4.54 > Trigonometry

**Property (6)**  $\tan^{-1}x - \tan^{-1}y =$

$$\begin{cases} \tan^{-1}\left(\frac{x-y}{1+xy}\right), & \text{if } xy > -1 \\ \pi + \tan^{-1}\left(\frac{x-y}{1+xy}\right), & \text{if } x > 0, y < 0 \text{ and } xy < -1 \\ -\pi + \tan^{-1}\left(\frac{x-y}{1+xy}\right), & \text{if } x < 0, y > 0 \text{ and } xy < -1 \\ \frac{\pi}{2} & \text{for } x > 0, y < 0 \text{ and } xy = -1 \\ -\frac{\pi}{2} & \text{for } x < 0, y > 0 \text{ and } xy = -1 \end{cases}$$

**Proof 5:** Let  $\tan^{-1}x = A$  and  $\tan^{-1}y = B$ . Then,

$$x = \tan A \text{ and } y = \tan B \text{ and } A, B \in (-\pi/2, \pi/2)$$

$$\therefore \tan(A+B) = \frac{\tan A + \tan B}{1 - \tan A \tan B} = \frac{x+y}{1-xy} \quad \dots (i)$$

Now, the following cases arise:

**Case I:** When  $x > 0, y > 0$  and  $xy < 1$ : In this case,

$$x > 0, y > 0 \text{ and } xy < 1 \Rightarrow \frac{x+y}{1-xy} > 0$$

$$\Rightarrow \tan(A+B) > 0$$

$$\Rightarrow A+B \text{ lies in I quadrant or in III quadrant.}$$

$$\Rightarrow 0 < A+B < \pi/2$$

$$\left\{ \begin{array}{l} \because x > 0 \Rightarrow 0 < A < \pi/2 \\ y > 0 \Rightarrow 0 < B < \pi/2 \end{array} \right\} \Rightarrow \{0 < A+B < \pi/2\}$$

$$\therefore \tan(A+B) = \frac{x+y}{1-xy} \quad \{\text{from (i)}\}$$

$$\Rightarrow A+B = \tan^{-1}\left(\frac{x+y}{1-xy}\right)$$

$$\Rightarrow \tan^{-1}x + \tan^{-1}y = \tan^{-1}\left(\frac{x+y}{1-xy}\right)$$

**Case II:** When  $x < 0, y < 0$  and  $xy < 1$ .

In this case;  $x < 0, y < 0$  and  $xy < 1$

$$\Rightarrow \frac{x+y}{1-xy} < 0 \Rightarrow \tan(A+B) < 0 \quad \{\text{from (i)}\}$$

$$\Rightarrow A+B \text{ lies in II quadrant or in IV quadrant}$$

$$\Rightarrow A+B \text{ lies in IV quadrant}$$

$$\left\{ \begin{array}{l} \because x < 0 \Rightarrow -\pi/2 < A < 0 \\ y < 0 \Rightarrow -\pi/2 < B < 0 \end{array} \right\} \Rightarrow -\pi < A+B < 0\}$$

$$\therefore -\pi/2 < A+B < 0 \therefore \tan(A+B) = \frac{x+y}{1-xy} \quad \{\text{from (i)}\}$$

$$\Rightarrow A+B = \tan^{-1}\frac{x+y}{1-xy}$$

$$\Rightarrow \tan^{-1}x + \tan^{-1}y = \tan^{-1}\frac{x+y}{1-xy}$$

**Case III:** When  $x > 0$  and  $y < 0$  or  $x < 0$  and  $y > 0$

Let,  $x > 0$  and  $y < 0$

$$\Rightarrow A \in (0, \pi/2) \text{ and } B \in (-\pi/2, 0)$$

$$\Rightarrow A+B \in (-\pi/2, \pi/2)$$

$$\therefore \tan(A+B) = \frac{x+y}{1-xy} \quad \{\text{from (i)}\}$$

$$\Rightarrow A+B = \tan^{-1}\left(\frac{x+y}{1-xy}\right)$$

$$\Rightarrow \tan^{-1}x + \tan^{-1}y = \tan^{-1}\left(\frac{x+y}{1-xy}\right)$$

Similarly, if  $x < 0$  and  $y > 0$ , we have

$$\Rightarrow \tan^{-1}x + \tan^{-1}y = \tan^{-1}\left(\frac{x+y}{1-xy}\right)$$

It follows from above three cases that:

$$\tan^{-1}x + \tan^{-1}y = \tan^{-1}\left(\frac{x+y}{1-xy}\right); \text{ if } xy < 1.$$

**Case IV:**  $x > 0, y > 0$  and  $xy > 1$ .

In this case, we have  $x > 0, y > 0$  and  $xy > 1$

$$\Rightarrow \frac{x+y}{1-xy} < 0$$

$$\Rightarrow \tan(A+B) < 0 \left\{ \text{from (i), } \tan(A+B) = \frac{x+y}{1-xy} \right\}$$

$$\Rightarrow A+B \text{ lies in II quadrant or in IV quadrant.}$$

$$\Rightarrow A+B \text{ lies in II quadrant}$$

$$\left\{ \begin{array}{l} \because x > 0, y > 0 \Rightarrow A, B \in (0, \pi/2) \\ \Rightarrow A, B \in (0, \pi) \end{array} \right.$$

$$\Rightarrow \pi/2 < A+B < \pi \Rightarrow \pi/2 - \pi < (A+B) - \pi < 0$$

$$\Rightarrow -\pi/2 < (A+B) - \pi < 0 \Rightarrow \tan(A+B) = \left(\frac{x+y}{1-xy}\right).$$

$$\{\because \tan(\pi - (A+B)) = -\tan(A+B)\}$$

$$\Rightarrow -\tan\{\pi - (A+B)\} = \left(\frac{x+y}{1-xy}\right)$$

$$\begin{aligned} \Rightarrow \tan\{(A+B)-\pi\} &= \left(\frac{x+y}{1-xy}\right) \\ \Rightarrow (A+B-\pi) &= \tan^{-1}\left(\frac{x+y}{1-xy}\right) \\ \Rightarrow A+B-\pi &= \tan^{-1}\left(\frac{x+y}{1-xy}\right) \\ \Rightarrow A+B &= \pi + \tan^{-1}\left(\frac{x+y}{1-xy}\right) \\ \Rightarrow \tan^{-1}x + \tan^{-1}y &= \pi + \tan^{-1}\left(\frac{x+y}{1-xy}\right) \end{aligned}$$

**Case V:** When  $x < 0, y < 0$  and  $xy > 1$   
 In this case, we have  $x < 0, y < 0$  and  $xy > 1$

$$\begin{aligned} \Rightarrow \frac{x+y}{1-xy} &> 0 \\ \Rightarrow \tan(A+B) &> 0 \left\{ \text{from (i), } \tan(A+B) = \frac{x+y}{1-xy} \right\} \\ \Rightarrow A+B &\text{ lies either in I quadrant or III quadrant.} \\ &\{\because x < 0, y < 0 \Rightarrow A, B \in (-\pi/2, 0)\} \\ \Rightarrow A+B &\in (-\pi, 0) \\ \Rightarrow A+B &\text{ lies in III quadrant} \\ \Rightarrow -\pi &< A+B < -\pi/2. \\ \Rightarrow \pi - \pi &< \pi + (A+B) < \pi - \pi/2 \\ \Rightarrow 0 &< \pi + (A+B) < \pi/2 \\ \text{Now, } \tan(A+B) &= \frac{x+y}{1-xy}. \quad \{\text{from (i)}\} \\ \Rightarrow \tan(\pi + (A+B)) &= \frac{x+y}{1-xy} \\ \Rightarrow \pi + A+B &= \tan^{-1}\left(\frac{x+y}{1-xy}\right) \\ \Rightarrow A+B &= -\pi + \tan^{-1}\left(\frac{x+y}{1-xy}\right) \\ \Rightarrow \tan^{-1}x + \tan^{-1}y &= -\pi + \tan^{-1}\left(\frac{x+y}{1-xy}\right) \end{aligned}$$

**Case (vi)** when  $x > 0, y > 0$  and  $x \cdot y = 1$

$$\begin{aligned} \text{then } \tan^{-1}x + \tan^{-1}y &= \tan^{-1}x + \tan^{-1}\left(\frac{1}{x}\right) \\ &= \tan^{-1}x + \cot^{-1}x = \frac{\pi}{2} \end{aligned}$$

**Case (vii)** when  $x < 0, y < 0$  and  $x \cdot y = 1$

$$\begin{aligned} \text{then } \tan^{-1}x + \tan^{-1}y &= \tan^{-1}x + \tan^{-1}\left(\frac{1}{x}\right) \\ &= \tan^{-1}x - \pi + \cot^{-1}x \\ &= \tan^{-1}x + \cot^{-1}x - \pi \\ &= \frac{\pi}{2} - \pi = -\frac{\pi}{2} \end{aligned}$$

**Proof (6)** Let,  $\tan^{-1}x = A$  and  $\tan^{-1}y = B$ . Then,

$$\begin{aligned} \Rightarrow x &= \tan A, y = \tan B \text{ and } A, B \in (-\pi/2, \pi/2) \\ \therefore \tan(A-B) &= \frac{\tan A - \tan B}{1 + \tan A \tan B} \\ \Rightarrow \tan(A-B) &= \frac{x-y}{1+xy}. \quad (i) \end{aligned}$$

**Case I:** When  $xy > -1$ , If  $x > 0$  and  $y > 0$ , then  
 $A \in (0, \pi/2), B \in (0, \pi/2)$

$$\begin{aligned} \Rightarrow A-B &\in (-\pi/2, \pi/2) \therefore \tan(A-B) = \frac{x-y}{1+xy} \{\text{from (i)}\} \\ \Rightarrow A-B &= \tan^{-1}\left(\frac{x-y}{1-xy}\right) \end{aligned}$$

**Case II:** When  $x \cdot y > -1$ , If  $x < 0$  and  $y < 0$ , then

$$\begin{aligned} A &\in \left(-\frac{\pi}{2}, 0\right); B \in \left(-\frac{\pi}{2}, 0\right) \\ \Rightarrow A &\in \left(-\frac{\pi}{2}, 0\right); -B \in \left(0, -\frac{\pi}{2}\right) \\ \Rightarrow A-B &\in \left(-\frac{\pi}{2}, \frac{\pi}{2}\right) \\ \Rightarrow \tan(A-B) &= \frac{x-y}{1+xy} \Rightarrow A-B = \tan^{-1}\left(\frac{x-y}{1+xy}\right) \end{aligned}$$

**Case III:** When  $xy > -1$

If  $x < 0$  and  $y > 0$

$$\begin{aligned} \Rightarrow A &\in \left(-\frac{\pi}{2}, 0\right); B \in \left(0, \frac{\pi}{2}\right) \\ \Rightarrow A &\in \left(-\frac{\pi}{2}, 0\right); -B \in \left(-\frac{\pi}{2}, 0\right) \\ \therefore A-B &\in (-\pi, 0) \\ \text{From (i), } \tan(A-B) &= \frac{x-y}{1+xy} \\ \therefore x < 0, y > 0 \text{ and } xy > -1 &\therefore \frac{x-y}{1+xy} < 0 \\ \Rightarrow A-B &\text{ lies in II and or IVth} \\ &\text{quad, and as } A-B \in (-\pi, 0) \end{aligned}$$

4.56 > Trigonometry

$$\Rightarrow A - B \in \left(-\frac{\pi}{2}, 0\right)$$

$$\therefore \tan(A - B) = \frac{x - y}{1 + xy} \Rightarrow A - B = \tan^{-1}\left(\frac{x - y}{1 + xy}\right)$$

Simillary, for  $x > 0$  and  $y < 0$ ,  $A - B = \tan^{-1}\left(\frac{x - y}{1 + xy}\right)$

$$\Rightarrow \tan^{-1} x - \tan^{-1} y = \tan^{-1}\left(\frac{x - y}{1 + xy}\right) \text{ for all } x, y \text{ with } xy > -1$$

**Case IV:** When  $x > 0$ ,  $y < 0$  and  $xy < -1$ .

In this case, we have  $x > 0$ ,  $y < 0$

$$\Rightarrow A \in (0, \pi/2), B \in (-\pi/2, 0)$$

$$\Rightarrow A \in (0, \pi/2), -B \in (0, \pi/2)$$

$$\Rightarrow A - B \in (0, \pi), \text{ Again, } x > 0, y < 0 \text{ and } xy < -1$$

$$\Rightarrow x > 0, -y > 0 \text{ and } 1 + xy < 0$$

$$\Rightarrow x - y > 0 \text{ and } 1 + xy < 0$$

$$\Rightarrow \frac{x - y}{1 + xy} < 0 \Rightarrow \tan(A - B) < 0$$

$$\Rightarrow A - B \in (\pi/2, \pi) \{ \because A - B \in (0, \pi) \}$$

$$\Rightarrow \pi/2 < A - B < \pi \Rightarrow -\pi/2 < (A - B) - \pi < 0$$

$$\therefore \tan(A - B) = \frac{x - y}{1 + xy} \text{ (from (i)), operating } \tan^{-1} \text{ both side}$$

$$-\tan[(\pi - (A - B))] = \left(\frac{x - y}{1 + xy}\right)$$

$$\Rightarrow \tan[(A - B) - \pi] = \left(\frac{x - y}{1 + xy}\right)$$

$$\Rightarrow -\pi + (A - B) = \tan^{-1}\left(\frac{x - y}{1 + xy}\right)$$

$$\Rightarrow A - B = \pi + \tan^{-1}\left(\frac{x - y}{1 + xy}\right)$$

$$\Rightarrow \tan^{-1} x - \tan^{-1} y = \pi + \tan^{-1}\left(\frac{x - y}{1 + xy}\right)$$

**Case V:** When  $x < 0$ ,  $y > 0$  and  $xy < -1$

In this case, we have  $x < 0$ ,  $y > 0$  and  $xy < -1$

$$\Rightarrow x - y < 0 \text{ and } 1 + xy < 0$$

$$\Rightarrow \frac{x - y}{1 + xy} > 0 \Rightarrow \tan(A - B) > 0 \quad \{\text{from (i)}\}$$

$$\Rightarrow (A - B) \text{ lies in I quadrant or in III quadrant.}$$

$$\Rightarrow -\pi < A - B < -\pi/2$$

$$\left\{ \begin{array}{l} \because x < 0, y > 0 \Rightarrow A \in (-\pi/2, 0), \\ \qquad \qquad \qquad B \in (0, \pi/2) \\ \qquad \qquad \qquad \Rightarrow -\pi < A - B < 0 \end{array} \right\}$$

$$\text{But } \tan(A - B) > 0 \Rightarrow A - B \in (-\pi, -\pi/2)$$

$$\Rightarrow 0 < \pi + (A - B) < \pi/2 \Rightarrow \tan(A - B) = \frac{x - y}{1 + xy}$$

$$\Rightarrow \tan\{\pi + (A - B)\} = \tan^{-1}\left(\frac{x - y}{1 + xy}\right)$$

$$\Rightarrow \pi + (A - B) = \tan^{-1}\left(\frac{x - y}{1 + xy}\right)$$

$$\Rightarrow A - B = -\pi + \tan^{-1}\left(\frac{x - y}{1 + xy}\right)$$

**Case (vi)** when  $x > 0$ ,  $y < 0$  and  $xy = -1$ ,

$$\text{then } \tan^{-1} x - \tan^{-1} y = \tan^{-1} x - \tan^{-1}\left(-\frac{1}{x}\right)$$

$$= \tan^{-1} x + \tan^{-1}\left(\frac{1}{x}\right) = \tan^{-1} x + \cot^{-1} x = \frac{\pi}{2}$$

**Case (vii)** when  $x < 0$ ,  $y > 0$  and  $xy = -1$ ,

$$\text{then } \tan^{-1} x - \tan^{-1} y = \tan^{-1} x - \tan^{-1}\left(-\frac{1}{x}\right)$$

$$= \tan^{-1} x + \tan^{-1}\left(\frac{1}{x}\right) = \tan^{-1} x - \pi + \cot^{-1} x$$

$$= -\pi + \tan^{-1} x + \cot^{-1} x = -\pi + \frac{\pi}{2} = -\frac{\pi}{2}$$

**ILLUSTRATION 46:** Solve the equation  $\sin^{-1} 2x + \sin^{-1} 3x = \pi/3$

**SOLUTION:**  $\frac{\pi}{2} - \cos^{-1} 2x + \frac{\pi}{2} - \cos^{-1} 3x = \frac{\pi}{3}$

$$\Rightarrow \pi - (\cos^{-1} 2x + \cos^{-1} 3x) = \frac{\pi}{3}$$

$$\Rightarrow \pi - \cos^{-1} \left[ (2x)(3x) - \sqrt{1 - (2x)^2} \sqrt{1 - (3x)^2} \right] = \frac{\pi}{3}$$

$$\text{For } 2x + 3x \geq 0 \Rightarrow x \geq 0$$

$$\Rightarrow \pi - \cos^{-1} \left[ 6x^2 - \sqrt{1-4x^2} \sqrt{1-9x^2} \right] = \frac{\pi}{3}$$

$$\Rightarrow \cos^{-1} \left( 6x^2 - \sqrt{1-4x^2} \sqrt{1-9x^2} \right) = \frac{2\pi}{3}$$

$$\Rightarrow 6x^2 - \sqrt{1-4x^2} \sqrt{1-9x^2} = -\frac{1}{2}$$

$$\Rightarrow 6x^2 + \frac{1}{2} = \sqrt{1-4x^2} \sqrt{1-9x^2}$$

$$\Rightarrow \left( 6x^2 + \frac{1}{2} \right)^2 = (1-4x^2)(1-9x^2)$$

$$\Rightarrow 36x^4 + \frac{1}{4} + 6x^2 = 1 - 13x^2 + 36x^4$$

$$\Rightarrow 19x^2 = 3/4 \Rightarrow x^2 = 3/76 \Rightarrow x = \pm \sqrt{\frac{3}{76}}$$

$$\text{But } x \geq 0 \Rightarrow x = \sqrt{\frac{3}{76}}$$

$$\text{for } 2x + 3x \leq 0; x \leq 0$$

$$\cos^{-1} 2x + \cos^{-1} 3x = 2\pi$$

$$-\cos^{-1} \left[ (2x) - (3x) - \sqrt{1-4x^2} \sqrt{1-9x^2} \right]$$

on solving gives

$$-\pi + \cos^{-1} \left( 6x^2 - \sqrt{1-4x^2} \sqrt{1-9x^2} \right) = \frac{\pi}{3}$$

$$\Rightarrow \cos^{-1} \left( 6x^2 - \sqrt{1-4x^2} \sqrt{1-9x^2} \right) = \frac{4\pi}{3}$$

which is impossible

**ILLUSTRATION 47:** Find the value of

(i)  $\cos \left( \tan^{-1} \frac{1}{3} + \tan^{-1} \frac{1}{2} \right)$

(ii)  $\tan \left( \frac{x}{y} \right) + \tan^{-1} \left( \frac{x+y}{x-y} \right); x > 0, y > 0 \text{ and } x > y$

**SOLUTION:** (i)  $\cos \left( \tan^{-1} \frac{1}{3} + \tan^{-1} \frac{1}{2} \right) = \cos \left[ \tan^{-1} \left( \frac{\frac{1}{3} + \frac{1}{2}}{1 - \frac{1}{3} \cdot \frac{1}{2}} \right) \right] = \cos \left[ \tan^{-1} \left( \frac{2+3}{6/5} \right) \right]$

$$= \cos[\tan^{-1}(1)] = \cos \left[ \frac{\pi}{4} \right] = \frac{1}{\sqrt{2}} \text{ Ans.}$$

(ii)  $\tan \left( \frac{x}{y} \right) + \tan^{-1} \left( \frac{x+y}{x-y} \right); x > 0, y > 0 \text{ and } x > y = \tan^{-1} \left( \frac{x}{y} \right) + \tan^{-1} \left( \frac{1+y/x}{1-y/x} \right)$

$$= \tan^{-1} \left( \frac{x}{y} \right) + \tan^{-1} 1 + \tan^{-1} \left( \frac{y}{x} \right) = \tan^{-1} \left( \frac{x}{y} \right) + \frac{\pi}{4} + \cot^{-1} \left( \frac{x}{y} \right)$$

$$\left[ \begin{array}{l} \because x > y \text{ and } x > 0, y > 0 \\ \Rightarrow \frac{y}{x} < 1 \\ \text{and } \tan^{-1} x + \tan^{-1} y \\ = \tan^{-1} \left( \frac{x+y}{1-xy} \right) \text{ for } xy < 1 \end{array} \right]$$

$$= \frac{\pi}{2} + \frac{\pi}{4} = \frac{3\pi}{4}$$



**ILLUSTRATION 48:** Solve the equation  $\tan^{-1}\left(\frac{x-1}{x-2}\right) + \tan^{-1}\left(\frac{x+1}{x+2}\right) = \frac{\pi}{4}$ ;  $x \in (-2, 2)$

**SOLUTION:**  $\therefore \tan^{-1}x + \tan^{-1}y = \tan^{-1}\left(\frac{x+y}{1-xy}\right)$  if  $xy < 1$

$$\text{Here } \frac{x-1}{x-2} \times \frac{x+1}{x+2} = \frac{x^2-1}{x^2-4} < 1$$

$$\Rightarrow \frac{x^2-1-x^2+4}{x^2-4} < 0 \Rightarrow \frac{3}{x^2-4} < 0 \Rightarrow x \in (-2, 2)$$

$$\therefore \text{ We have, } \tan^{-1}\left[\frac{\frac{x-1}{x-2} + \frac{x+1}{x+2}}{1 - \left(\frac{x^2-1}{x^2-4}\right)}\right] = \frac{\pi}{4}$$

$$\Rightarrow \frac{2x^2-4}{-3} = 1 \Rightarrow 2x^2-4 = -3 = 2x^2 = 1 \Rightarrow x = \pm \frac{1}{\sqrt{2}} \in (-2, 2)$$

**ILLUSTRATION 49:** Solve the equation

$$(i) \tan^{-1}\left(\frac{1-x}{1+x}\right) = \frac{1}{2}\tan^{-1}x; x \in (0, 1)$$

$$(ii) 3\tan^{-1}\left(\frac{1}{2+\sqrt{3}}\right) - \tan^{-1}\left(\frac{1}{x}\right) = \tan^{-1}\left(\frac{1}{3}\right)$$

**SOLUTION:** (i)  $\tan^{-1}\left(\frac{1-x}{1+x}\right) = \frac{1}{2}\tan^{-1}x$

$$\Rightarrow 2\tan^{-1}\left(\frac{1-x}{1+x}\right) = \tan^{-1}x$$

$$\therefore x \in (0, 1) \Rightarrow -x \in (-1, 0) \text{ and } 1-x \in (0, 1)$$

$$\text{Also } 1+x \in (1, 2)$$

$$\therefore 0 < 1-x < 1+x$$

$$\Rightarrow 0 < \frac{1-x}{1+x} < 1 \quad \left[ \because 2\tan^{-1}x = \tan^{-1}\left(\frac{2x}{1-x^2}\right) \text{ for } -1 < x < 1 \right]$$

$$\therefore \tan^{-1}\left(\frac{2\left(\frac{1-x}{1+x}\right)}{1 - \left(\frac{1-x}{1+x}\right)^2}\right) = \tan^{-1}x \Rightarrow \tan^{-1}\left(\frac{1-x^2}{2x}\right) = \tan^{-1}x$$

$$\Rightarrow \frac{1-x^2}{2x} = x \Rightarrow 1-x^2 = 2x^2 \Rightarrow x = \pm \frac{1}{\sqrt{3}}$$

$$\text{As } x \in (0, 1)$$

$$\therefore x = \frac{1}{\sqrt{3}}$$

$$(ii) 3 \tan^{-1} \left( \frac{1}{2+\sqrt{3}} \right) - \tan^{-1} \left( \frac{1}{x} \right) = \tan^{-1} \left( \frac{1}{3} \right)$$

$$\left[ 3 \tan^{-1} x = \tan^{-1} \left( \frac{3x - x^3}{1 - 3x^2} \right) \text{ for } \frac{-1}{\sqrt{3}} < x < \frac{1}{\sqrt{3}} \right]$$

Clearly,  $2 + \sqrt{3} > \sqrt{3} > 0$

$$\Rightarrow 0 < \frac{1}{2+\sqrt{3}} < \frac{1}{\sqrt{3}}$$

$$\therefore 3 \tan^{-1} \left( \frac{1}{2+\sqrt{3}} \right) = \tan^{-1} \left[ \frac{3 \left( \frac{1}{2+\sqrt{3}} \right) - \left( \frac{1}{2+\sqrt{3}} \right)^3}{1 - 3 \left( \frac{1}{2+\sqrt{3}} \right)^2} \right] = \tan^{-1} \left[ \frac{3(2-\sqrt{3}) - (2-\sqrt{3})^3}{1 - 3(2-\sqrt{3})^2} \right]$$

$$= \tan^{-1} \left[ \frac{6 - 3\sqrt{3} - 8 + 3\sqrt{3} + 12\sqrt{3} - 18}{1 - 21 + 12\sqrt{3}} \right] = \tan^{-1} \left[ \frac{12\sqrt{3} - 20}{12\sqrt{3} - 20} \right] = \tan^{-1}(1) = \pi/4$$

$$\therefore \text{We have, } \frac{\pi}{4} - \tan^{-1} \frac{1}{x} = \tan^{-1} \left( \frac{1}{3} \right)$$

$$\therefore \tan^{-1} 1 - \tan^{-1} \frac{1}{x} = \tan^{-1} \frac{1}{3}$$

$$\tan^{-1} \left[ \frac{1 - \frac{1}{x}}{1 + \frac{1}{x}} \right] = \tan^{-1} \left( \frac{1}{3} \right) \quad \left[ \because x \cdot \frac{1}{x} = 1, \frac{1}{3} = \frac{1}{3} > -1 \right]$$

$$\Rightarrow \tan^{-1} \left( \frac{2/3}{4/3} \right) = \tan^{-1} \left( \frac{1}{x} \right)$$

$$\Rightarrow \tan^{-1} \left( \frac{1}{2} \right) = \tan^{-1} \left( \frac{1}{x} \right)$$

$$\Rightarrow x = 2$$

**ILLUSTRATION 50:** Evaluate  $\sum_{n=1}^{\infty} \tan^{-1} \left[ \frac{4n}{n^4 - 2n^2 + 2} \right]$ .

**SOLUTION:**  $\sum_{n=1}^{\infty} \tan^{-1} \left[ \frac{4n}{(n^2 - 1)^2 + 1} \right]$

$$= \sum_{n=1}^{\infty} \tan^{-1} \left[ \frac{4n}{1 + (n+1)^2 (n-1)^2} \right] = \sum_{n=1}^{\infty} \tan^{-1} \left[ \frac{(n+1)^2 - (n-1)^2}{1 + (n+1)^2 (n-1)^2} \right]$$

$$= \sum_{n=1}^{\infty} \left[ \tan^{-1} (n+1)^2 - \tan^{-1} (n-1)^2 \right]$$

$$\left[ \because x \cdot y = (n+1)^2 (n-1)^2 > -1 \right]$$

$$\begin{aligned}
 &= \lim_{k \rightarrow \infty} \sum_{n=1}^k \left\{ \tan^{-1}(n+1)^2 - \tan^{-1}(n-1)^2 \right\} = \lim_{k \rightarrow \infty} \left[ \begin{array}{l} \tan^{-1}(2)^2 - \tan^{-1}(0)^2 \\ + \tan^{-1}(3)^2 - \tan^{-1}(1)^2 \\ + \tan^{-1}(4)^2 - \tan^{-1}(2)^2 \\ + \tan^{-1}(5)^2 - \tan^{-1}(3)^2 \\ + \dots + \tan^{-1}(k+1)^2 - \tan^{-1}(k-1)^2 \end{array} \right] \\
 &= \lim_{k \rightarrow \infty} \tan^{-1}(k)^2 + \tan^{-1}(k+1)^2 - \tan^{-1}(1)^2 - \tan^{-1}(0)^2 \quad [\text{All other terms cancel out}] \\
 &= \frac{\pi}{2} + \frac{\pi}{2} - \frac{\pi}{4} = \frac{3\pi}{4}
 \end{aligned}$$

**ILLUSTRATION 51:** Find the sum of the following series:

$$\begin{aligned}
 &\tan^{-1}\left(\frac{1}{x^2+x+1}\right) + \tan^{-1}\left(\frac{1}{x^2+3x+3}\right) + \tan^{-1}\left(\frac{1}{x^2+5x+7}\right) \\
 &+ \tan^{-1}\left(\frac{1}{x^2+7x+13}\right) + \dots \text{to } n \text{ terms; assuming the quadratic in denominators are +ve.}
 \end{aligned}$$

**SOLUTION:**

$$\begin{aligned}
 &\tan^{-1}\left(\frac{1}{1+x(1+x)}\right) + \tan^{-1}\left(\frac{1}{1+(x+1)(x+2)}\right) + \dots \text{to } n \text{ - terms} \\
 &= \sum_{r=1}^n \tan^{-1}\left[\frac{(x+r)-(x+r-1)}{1+(x+r-1)(x+r)}\right] = \sum_{r=1}^n \left\{ \tan^{-1}(x+r) - \tan^{-1}(x+r-1) \right\}
 \end{aligned}$$

$$[\because 1 + (x+r)(x+r-1) > 0 \Rightarrow (x+r)(x+r-1) > -1]$$

$$= \left\{ \begin{array}{l} \tan^{-1}(x+1) - \tan^{-1}x \\ + \tan^{-1}(x+2) - \tan^{-1}(x+1) \\ + \tan^{-1}(x+3) - \tan^{-1}(x+2) \\ + \\ + \dots + \tan^{-1}(x+n) - \tan^{-1}(x+n-1) \end{array} \right\} = \tan^{-1}(x+n) - \tan^{-1}x$$

**ILLUSTRATION 52:** If  $\alpha$  and  $\beta$  are the roots of the equation  $x^2 + 5x - 49 = 0$ , then find the value of  $\cot(\cot^{-1}\alpha + \cot^{-1}\beta)$ .

**SOLUTION:**  $x^2 + 5x - 49 = 0$

$$\Rightarrow \alpha + \beta = -5$$

and  $\alpha\beta = -49 \Rightarrow \alpha$  and  $\beta$  are of opposite signs, let  $\alpha > 0$ ;  $\beta < 0$

$$\begin{aligned}
 \therefore \cot[\cot^{-1}\alpha + \cot^{-1}\beta] &= \cot\left[\tan^{-1}\left(\frac{1}{\alpha}\right) + \pi + \tan^{-1}\left(\frac{1}{\beta}\right)\right] \\
 &= \cot\left[\pi + \left(\tan^{-1}\frac{1}{\alpha} + \tan^{-1}\frac{1}{\beta}\right)\right] = \cot\left[\pi + \tan^{-1}\left(\frac{\frac{1}{\alpha} + \frac{1}{\beta}}{1 - \frac{1}{\alpha\beta}}\right)\right]
 \end{aligned}$$

$$\begin{aligned} & \left[ \because \frac{1}{\alpha} \cdot \frac{1}{\beta} = \frac{1}{\alpha\beta} = -\frac{1}{49} < 1 \right] = \cot \left[ \pi + \tan^{-1} \left( \frac{\beta + \alpha}{\alpha\beta - 1} \right) \right] \\ & = \cot \left[ \pi + \tan^{-1} \left( \frac{-5}{-50} \right) \right] = \cot \left[ \pi + \tan^{-1} \left( \frac{1}{10} \right) \right] \\ & = \cot[\pi + \cot^{-1}(10)] = \cot[\cot^{-1}(10)] = 10 \end{aligned}$$

**ILLUSTRATION 53:** If  $a > b > c > 0$ , then find the value of:

$$\cot^{-1} \left( \frac{ab+1}{a-b} \right) + \cot^{-1} \left( \frac{bc+1}{b-c} \right) + \cot^{-1} \left( \frac{ca+1}{c-a} \right).$$

**SOLUTION:**  $\cot^{-1} \left( \frac{ab+1}{a-b} \right) + \cot^{-1} \left( \frac{bc+1}{b-c} \right) + \cot^{-1} \left( \frac{ca+1}{c-a} \right) = \tan^{-1} \left( \frac{a-b}{ab+1} \right) + \tan^{-1} \left( \frac{b-c}{bc+1} \right) + \tan^{-1} \left( \frac{c-a}{ca+1} \right)$

$$= \tan^{-1} a - \tan^{-1} b + \tan^{-1} b - \tan^{-1} c + \tan^{-1} c - \tan^{-1} a = 0$$

## TEXTUAL EXERCISE-5 (SUBJECTIVE)

1. Prove the following statements:

- (a)  $\tan^{-1}1 + \tan^{-1}2 + \tan^{-1}3 = \pi$   
 (b)  $\tan^{-1}1/7 + \tan^{-1}1/13 = \tan^{-1}2/9$   
 (c)  $\tan^{-1}3/4 + \tan^{-1}3/5 - \tan^{-1}8/19 = \pi/4$

2. Prove the following:

- (i)  $\sin^{-1} \frac{3}{5} + \sin^{-1} \frac{8}{17} = \sin^{-1} \frac{77}{85}$   
 (ii)  $\sin^{-1} \frac{5}{13} + \sin^{-1} \frac{7}{25} = \cos^{-1} \left( \frac{253}{325} \right)$   
 (iii)  $\sin^{-1} \frac{3}{5} - \cos^{-1} \frac{12}{13} = \sin^{-1} \frac{16}{65}$

3. Prove that following:

- (i)  $\cos^{-1} \frac{4}{5} + \cos^{-1} \frac{12}{13} = \cos^{-1} \left( \frac{33}{65} \right)$   
 (ii)  $\cos^{-1} \left( \frac{1}{2} \right) + \cos^{-1} \left( -\frac{1}{7} \right) + \cos^{-1} \left( \frac{13}{14} \right)$

4. (a) Prove that

$$\begin{aligned} & \sin^{-1} \left( \frac{1}{\sqrt{2}} \right) + \sin^{-1} \left( \frac{\sqrt{2}-1}{\sqrt{6}} \right) + \sin^{-1} \left( \frac{\sqrt{3}-\sqrt{2}}{\sqrt{12}} \right) + \dots + \\ & \sin^{-1} \left( \frac{\sqrt{n}-\sqrt{n-1}}{\sqrt{n(n+1)}} \right) + \dots = \pi/2 \end{aligned}$$

(b) Prove that

$$\begin{aligned} & \cot^{-1} \left( 1^2 - \frac{3}{4} \right) + \cot^{-1} \left( 2^2 - \frac{3}{4} \right) + \\ & \cot^{-1} \left( 3^2 - \frac{3}{4} \right) + \dots = \pi - \tan^{-1} 2 \end{aligned}$$

5. Solve the equation  $\sin^{-1}6x + \sin^{-1}6\sqrt{3}x = \pi/2$ .

6. (a) If  $\sum \sin^{-1}x = \pi$  then prove that  $x^4 + y^4 + z^4 + 4x^2y^2z^2 = 2(x^2y^2 + y^2z^2 + z^2x^2)$ .

(b) If  $\cos^{-1}x + \cos^{-1}y + \cos^{-1}z = \pi$  then prove that  $x^2 + y^2 + z^2 + 2xyz = 1$ .

7. (a)  $\tan^{-1} \left( \frac{x+1}{x-1} \right) + \tan^{-1} \left( \frac{x-1}{x} \right) = \tan^{-1}(-7)$

(b)  $\tan^{-1}(x-1) + \tan^{-1}(x) + \tan^{-1}(x+1) = \tan^{-1}3x$

8. Find the value of

$$\begin{aligned} & \tan[\operatorname{cosec}^{-1}\sqrt{10} + \operatorname{cosec}^{-1}\sqrt{50} + \operatorname{cosec}^{-1}\sqrt{170} \\ & + \dots + \operatorname{cosec}^{-1}\sqrt{(n^2+1)(n^2+2n+2)} + \dots] \end{aligned}$$

9. Evaluate the following and hence find  $S_{\infty}$ .

(a)  $\sum_{k=1}^n \tan^{-1} \frac{2K}{2+K^2+K^4}$

4.62 > Trigonometry

(b)  $\sum_{k=1}^n \tan^{-1} \frac{x}{1+K(K+1)x^2}, x > 0$

(c)  $\cot^{-1}2 + \cot^{-1}8 + \cot^{-1}18 + \cot^{-1}32 \dots$  to  $n$  terms

(d)  $\sum_{r=1}^n \tan^{-1} \frac{2^{r-1}}{1+2^{2r-1}}$

10. Evaluate the expression

$$\cot \left[ \begin{array}{l} \tan^{-1} \frac{4}{1+3.4} + \tan^{-1} \frac{6}{1+8.9} + \\ \tan^{-1} \frac{8}{1+15.16} + \tan^{-1} \frac{10}{1+24.25} + \dots \end{array} \right]$$

11. If the sum of the series:  $\sum_{n=1}^{\infty} \left( \frac{\sec^{-1} \sqrt{|x|} + \operatorname{cosec}^{-1} \sqrt{|x|}}{\pi a} \right)^n$

is finite, where  $|x| \geq 1$  and  $a > 0$ , then find the range of values of  $a$ ?

12. Find the value of  $x$  and  $y$  when  $\sin^{-1}x + \sin^{-1}y = 2\pi/3$  and  $\cos^{-1}x - \cos^{-1}y = \pi/3$ .

13. If  $a, b, c$  are positive real numbers then prove that

$$\tan^{-1} \sqrt{\frac{a(a+b+c)}{bc}} + \tan^{-1} \sqrt{\frac{b(a+b+c)}{ca}} + \tan^{-1} \sqrt{\frac{c(a+b+c)}{ab}} = \pi.$$

14. If  $p > q > 0$  and  $pr < -1 < qr$ , then prove that

$$\tan^{-1} \frac{p-q}{1+pq} + \tan^{-1} \frac{q-r}{1+qr} + \tan^{-1} \frac{r-p}{1+rp} = \pi.$$

15. Find the solution of equation  $\sin^{-1} \sqrt{\frac{x}{1+x}} \sin \left( \frac{x}{x+1} \right) = \sin^{-1} \frac{1}{\sqrt{1+x}}$

16. Find the value of  $\sin^{-1} \left( \frac{3}{5} \right) - \cos^{-1} \left( \frac{12}{13} \right)$  in terms of sine inverse.

17. Solve the following equations:

(i)  $2\cot^{-1}2 - \cos^{-1} \frac{4}{5} = \operatorname{cosec}^{-1}x$

(ii)  $\sin[2\cos^{-1}\{\cot(2\tan^{-1}x)\}] = 0$

(iii)  $2\cot^{-1}2 + \cos^{-1}(3/5) = \operatorname{cosec}^{-1}x$

18. Prove the following equations:

(i)  $\sin^2 \left( \tan^{-1}3 - \cot^{-1} \left( -\frac{1}{2} \right) \right) = \frac{1}{2}$

(ii)  $\sin \left( 2\tan^{-1} \frac{1}{2} \right) + \tan \left( \frac{1}{2} \sin^{-1} \frac{15}{17} \right) = \frac{7}{5}$

(iii)  $\sin \left( 2\tan^{-1} \frac{1}{2} \right) - \tan \left( \frac{1}{2} \sin^{-1} \frac{15}{17} \right) = \frac{1}{5}$

Answer Keys

5.  $x = \frac{1}{12}$

7. (a) 2 (b)  $x = 1/2, 0, -1/2$

8. 1

9. (a)  $S_n = \tan^{-1} \left( \frac{n^2+n}{n^2+n+2} \right), S_{\infty} = \frac{\pi}{4}$  (b)  $S_n = \tan^{-1} \left( \frac{x}{1+n(n+1)x^2} \right), S_{\infty} = 0$

(c)  $S_n = \tan^{-1} \left( \frac{n}{n+1} \right), S_{\infty} = \frac{\pi}{4}$  (d)  $S_n = \tan^{-1}(2^n) - \frac{\pi}{4}, S_{\infty} = \frac{\pi}{4}$  10. 2

11.  $a \in \left( \frac{1}{2}, \infty \right)$

12.  $x = 1/2, y = 1$

15.  $x \geq 0$

16.  $\sin^{-1} \left( \frac{16}{65} \right)$

17. (i)  $x = 25/7$  (ii)  $1, (1 + \sqrt{2})$  (iii)  $x = 25/24$

TEXTUAL EXERCISE-5 (OBJECTIVE)

1. If  $\tan^{-1}x + \tan^{-1}y + \tan^{-1}z = \pi$ , then the value of  $x + y + z - xyz$  is

(a) 0

(b) 1

(c) -1

(d) 2

2. The sum  $\sum_{n=1}^{\infty} \tan^{-1} \frac{3}{n^2+n-1}$  is equal to

(a)  $\frac{\pi}{2}$

(b)  $-\pi + \tan^{-1}3$

(c)  $-\frac{\pi}{2} - \tan^{-1}2$

(d) None of these

3. If  $1 < x < \sqrt{2}$ , the number of solutions of the equation,  $\tan^{-1}(x-1) + \tan^{-1}x + \tan^{-1}(x+1) = \tan^{-1}3x$  is  
 (a) 0 (b) 1  
 (c) 2 (d) 3
4. If  $\tan^{-1}x - \tan^{-1}y = \tan^{-1}A$ , and  $xy > -1$ , then  $A$  is  
 (a)  $x-y$  (b)  $x+y$   
 (c)  $\frac{x-y}{1+xy}$  (d)  $\frac{x+y}{1-xy}$
5. If  $\cos^{-1}x + \cos^{-1}y + \cos^{-1}z = \pi$ , then  
 (a)  $x^2 + y^2 + z^2 + xyz = 0$   
 (b)  $x^2 + y^2 + z^2 + 2xyz = 1$   
 (c)  $x^2 + y^2 + z^2 + xyz = 1$   
 (d) None of these
6. If  $\tan^{-1}2x + \tan^{-1}3x = \frac{\pi}{4}$ , then  $x$  is equal to  
 (a)  $-1$  (b)  $\frac{1}{6}$   
 (c)  $-1, \frac{1}{6}$  (d) None of these
7. If  $\tan^{-1}x + \tan^{-1}y + \tan^{-1}z = \pi$  then  $\frac{1}{xy} + \frac{1}{yz} + \frac{1}{zx}$  is  
 (a) 0 (b) 1  
 (c)  $\frac{1}{xyz}$  (d)  $xyz$
8. If  $\cot^{-1}\alpha + \cot^{-1}\beta = \cot^{-1}x$ , then  $x$  is equal to  
 (a)  $\alpha + \beta$  (b)  $\alpha - \beta$   
 (c)  $\frac{1 + \alpha\beta}{\alpha + \beta}$  (d)  $\frac{\alpha\beta - 1}{\alpha + \beta}$
9.  $\tan^{-1}\frac{3}{4} + \tan^{-1}\frac{3}{5} - \cot^{-1}8$  is equal to  
 (a)  $\frac{\pi}{4}$  (b)  $\frac{\pi}{3}$   
 (c)  $\frac{\pi}{6}$  (d) None of these
10. If  $\sin^{-1}\frac{1}{3} + \sin^{-1}\frac{2}{3} = \sin^{-1}x$ , then  $x$  is equal to:  
 (a) 0 (b)  $\frac{\sqrt{5} - 4\sqrt{2}}{9}$   
 (c)  $\frac{\sqrt{5} + 4\sqrt{2}}{9}$  (d)  $\frac{\pi}{2}$
11.  $\tan^{-1}\left(\frac{x}{y}\right) - \tan^{-1}\left(\frac{x-y}{x+y}\right)$  is  
 (a)  $\frac{\pi}{2}$  (b)  $\frac{\pi}{3}$   
 (c)  $\frac{\pi}{4}$  (d)  $\frac{\pi}{4}$  or  $-\frac{3\pi}{4}$
12.  $\cos^{-1}\left(\frac{15}{17}\right) + 2\tan^{-1}\left(\frac{1}{5}\right)$  is equal to  
 (a)  $\frac{\pi}{2}$  (b)  $\sin^{-1}\left(\frac{171}{221}\right)$   
 (c)  $\frac{\pi}{6}$  (d) None of these
13. If  $\tan^{-1}x + \cos^{-1}\frac{y}{\sqrt{1+y^2}} = \sin^{-1}\frac{3}{\sqrt{10}}$  and both  $x$  and  $y$  are positive and integral, then  $x$  and  $y$  is equal to  
 (a) (1, 2) and (2, 7) (b) (1, 2) and (1, 7)  
 (c) (1, 7) and (2, 7) (d) (1, 7) and (2, 1)
14. If in a triangle, two angles are  $\tan^{-1}2$  and  $\tan^{-1}3$ , then the third angle is  
 (a)  $\frac{\pi}{4}$  (b)  $\frac{3\pi}{4}$   
 (c) Cannot be evaluated (d) None of these
15.  $\tan^{-1}\left(\frac{1}{3}\right) + \tan^{-1}\left(\frac{1}{5}\right) + \tan^{-1}\left(\frac{1}{7}\right) + \tan^{-1}\left(\frac{1}{8}\right)$  equals  
 (a)  $\frac{5\pi}{4}$  (b)  $\frac{\pi}{2}$   
 (c)  $\frac{\pi}{4}$  (d)  $\pi$

## Answer Keys

1. (a) 2. (b, c) 3. (a) 4. (c) 5. (b) 6. (b) 7. (b) 8. (d) 9. (a) 10. (c)  
 11. (d) 12. (b) 13. (a) 14. (b) 15. (c)

## MULTIPLE CHOICE QUESTIONS

### SECTION-I

#### OBJECTIVE SOLVED EXAMPLES

1. Range of function  $\sqrt[4]{|\sin^{-1}|\sin x| + |\cos^{-1}|\cos x|}$  is

- (a)  $[0, \infty)$                       (b)  $[\sqrt[4]{\pi}, \sqrt[4]{2\pi}]$   
 (c)  $[0, \sqrt[4]{\pi}]$                       (d) None of these

**Solution:**  $f(x) = \sqrt[4]{|\sin^{-1}|\sin x| + |\cos^{-1}|\cos x|}$   
 $= \sqrt[4]{\sin^{-1}|\sin x| + \cos^{-1}|\cos x|}$  ... (i)

( $\because \sin^{-1}|\theta|, \cos^{-1}|\theta| \geq 0$ )

Now  $\sin^{-1}|\sin x|$  and  $\cos^{-1}|\cos x|$  are periodic functions with period  $\pi$  as  $\sin^{-1}|\sin(\pi + x)| = \sin^{-1}|\sin x| = \sin^{-1}|\sin x|$  and  $\cos^{-1}|\cos(\pi + x)| = \cos^{-1}|\cos x| = \cos^{-1}|\cos x|$ . So for finding range we can take  $x$  only for one complete period say  $[0, \pi]$

**Case (i):** When  $x \in [0, \pi/2]$ ;  $|\sin x| = \sin x$  as  $\sin x \geq 0$   
 $\Rightarrow \sin^{-1}|\sin x| = \sin^{-1}(\sin x) = x$  as  $\sin^{-1}(\sin x) = x$  for

$x \in \left[-\frac{\pi}{2}, \frac{\pi}{2}\right]$  and  $|\cos x| = \cos x$  as  $\cos x \geq 0$

$\Rightarrow \cos^{-1}|\cos x| = \cos^{-1}(\cos x) = x$  and  
 as  $\cos^{-1}(\cos x) = x$  for  $x \in [0, \pi]$

$\therefore$  from (i),  $f(x) = \sqrt[4]{x+x} = \sqrt[4]{2x} \in [0, \sqrt[4]{\pi}]$

**Case (ii)** when  $x \in \left(\frac{\pi}{2}, \pi\right]$

$|\sin x| = \sin x$  as  $\sin x \geq 0$

$\Rightarrow \sin^{-1}|\sin x| = \sin^{-1}(\sin x) = \sin^{-1}(\sin(\pi - x))$   
 $= \pi - x$  as  $\pi - x \in \left[0, \frac{\pi}{2}\right]$

and  $|\cos x| = -\cos x$

$\Rightarrow \cos^{-1}|\cos x| = \cos^{-1}(-\cos x) = \cos^{-1}(\cos(\pi - x))$   
 $= \pi - x$  as  $\pi - x \in \left[0, \frac{\pi}{2}\right]$

$\therefore$  from (i),  $f(x) = \sqrt[4]{(2\pi - 2x)}$

Now

$(2\pi - 2x) \in [0, \pi] \Rightarrow f(x) \in \left[\sqrt[4]{0}, \sqrt[4]{\pi}\right]$

as  $f(x)$  is continuous

and decreasing function on  $\left(\frac{\pi}{2}, \pi\right]$

$\therefore$  Range of  $f(x) = [0, \sqrt[4]{\pi}]$

$\therefore$  (c) is correct option

2. Range of  $f(x) = \sin^{-1}x + \tan^{-1}x + \cos^{-1}x$  is

- (a)  $[0, \pi]$                       (b)  $\left[\frac{\pi}{4}, \frac{3\pi}{4}\right]$   
 (c)  $[-\pi, 2\pi]$                       (d) None of these

**Solution:**  $f(x) = \sin^{-1}x + \tan^{-1}x + \cos^{-1}x$

$\Rightarrow$  Domain of  $f(x) = [-1, 1]$

Now  $f(x) = \frac{\pi}{2} + \tan^{-1}x$  and it is an increasing and continuous functions on  $[-1, 1]$

$\Rightarrow$  Range of  $f(x) = [f(-1), f(1)] = \left[\frac{\pi}{4}, \frac{3\pi}{4}\right]$

$\Rightarrow$  (b) is correct option

3. The interval on which  $\cos^{-1}x > \sin^{-1}x > \tan^{-1}x$  is

- (a)  $\left(0, \frac{1}{\sqrt{2}}\right)$                       (b)  $[-1, 1]$   
 (c)  $(0, 1]$                       (d) None of these

**Solution:**  $\cos^{-1}x > \sin^{-1}x > \tan^{-1}x$  is defined for  $x \in [-1, 1]$ ; Now  $\cos^{-1}x > \sin^{-1}x$

$\Rightarrow \cos^{-1}x > \frac{\pi}{2} - \cos^{-1}x$

$\Rightarrow 2\cos^{-1}x > \frac{\pi}{2}$

$\Rightarrow \cos^{-1}x > \frac{\pi}{4}$

$$\Rightarrow \cos^{-1} x \in \left( \frac{\pi}{4}, \pi \right]$$

$\Rightarrow x \in [\cos \pi, \cos \pi/4]$  as  $\cos^{-1}x$  is a decreasing and continuous function

$$\Rightarrow x \in [-1, 1/\sqrt{2}]$$

Also from the graph given below, it is clear that  $\sin^{-1} x > \tan^{-1} x$  for  $x \in (0, 1]$  in the domain  $[-1, 1]$

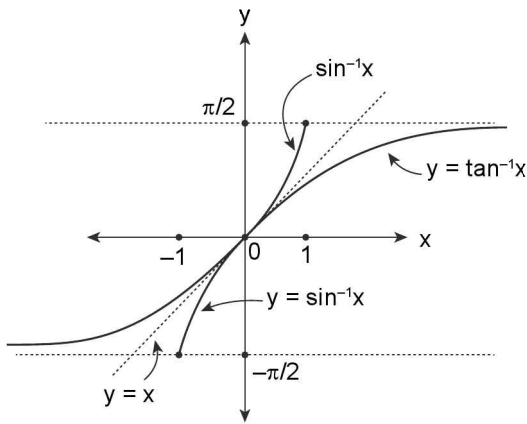

Thus  $\cos^{-1} x > \sin^{-1} x$  for  $x \in \left[-1, \frac{1}{\sqrt{2}}\right)$  and

$\sin^{-1} x > \tan^{-1} x$  for  $x \in (0, 1]$

$\therefore \cos^{-1} x > \sin^{-1} x > \tan^{-1} x$  for  $x \in$

$$\left[-1, \frac{1}{\sqrt{2}}\right) \cap (0, 1] = \left(0, \frac{1}{\sqrt{2}}\right)$$

$\therefore$  (a) is correct option

4. Ordered pair  $(x, y)$  satisfying the system of simultaneous equations  $\sin^{-1}x + \sin^{-1}2y = \pi$  and  $\cos^{-1}x + \cos^{-1}x^2 = 0$  is

- (a)  $(-1, -1/2)$                       (b)  $(1, -1/2)$   
 (c)  $(-1, 1/2)$                         (d)  $(1, 1/2)$

**Solution:**  $\sin^{-1} x \in \left[-\frac{\pi}{2}, \frac{\pi}{2}\right]$  and  $\sin^{-1} 2y \in \left[-\frac{\pi}{2}, \frac{\pi}{2}\right]$

$$\Rightarrow \sin^{-1} x + \sin^{-1} 2y \in [-\pi, \pi]$$

$\Rightarrow \sin^{-1} x + \sin^{-1} 2y = \pi$  occurs at extreme values of  $\sin^{-1}x$  and  $\sin^{-1}2y$  i.e.  $\sin^{-1} x = \pi/2$  and  $\sin^{-1} 2y = \pi/2$

$$\Rightarrow x = 1, 2y = 1$$

$$\Rightarrow x = 1, y = 1/2 \dots (i)$$

$$\text{Now } \cos^{-1} x + \cos^{-1} x^2 = 0$$

$\Rightarrow \cos^{-1} x = 0; \cos^{-1} x^2 = 0$  and  $\cos^{-1}x$  and  $\cos^{-1} x^2$  both are non-negative terms

$$\Rightarrow x = 1 \text{ and } x^2 = 1 \Rightarrow x = 1 \text{ and } x = \pm 1$$

$$\Rightarrow x = 1 \dots (ii)$$

$\therefore$  from (i) and (ii) solution of given equations would be  $x = 1, y = 1/2 \Rightarrow$  (d) is correct option.

5. The complete solution set of equation

$$\sin^{-1} |\sin x| = \sqrt{\sin^{-1} |\sin x|}$$

- (a)  $\{2n\pi \pm 1; n \in \mathbb{Z}\}$   
 (b)  $\{n\pi, n\pi \pm 1; n \in \mathbb{Z}\}$   
 (c)  $\left\{(2n+1)\frac{\pi}{2}; n \in \mathbb{Z}\right\}$   
 (d) None of these

**Solution:** Given equation is

$$\sin^{-1} |\sin x| = \sqrt{\sin^{-1} |\sin x|} \dots (i)$$

Let  $\sin^{-1} |\sin x| = t$

$$\Rightarrow t = \sqrt{t} \Rightarrow t^2 - t = 0 \Rightarrow t = 0 \text{ or } t = 1$$

$$\therefore t = 0 \Rightarrow \sin^{-1} |\sin x| = 0 \Rightarrow |\sin x| = 0 \Rightarrow \sin x = 0$$

$$\Rightarrow x = n\pi; n \in \mathbb{Z}$$

$$\text{and } t = 1 \Rightarrow \sin^{-1} |\sin x| = 1 \Rightarrow |\sin x| = \sin 1$$

(as  $\sin^{-1}x$  being increasing is one one)

$$\Rightarrow \sin x = \pm \sin 1 = \sin(\pm 1)$$

$$\Rightarrow x = n\pi + (-1)^n (\pm 1); n \in \mathbb{Z} \Rightarrow x = n\pi \pm 1; n \in \mathbb{Z}$$

$\therefore$  Complete solution set of equations is  $\{n\pi, n\pi \pm 1; n \in \mathbb{Z}\}$

$\therefore$  (b) is correct option.

6. If  $f(x) = \cos^{-1}(\cos x) - \sin^{-1}(\sin x)$ ; then the area bounded by  $f(x)$  and  $x$ -axis on  $-\pi$ -interval  $[-6\pi, 6\pi]$  is

- (a)  $12\pi^2$                                       (b)  $3\pi^2$   
 (c)  $6\pi^2$                                         (d) None of these

**Solution:**  $\cos^{-1}(\cos x) = \begin{cases} x; 0 \leq x \leq \pi \\ 2\pi - x; \pi \leq x \leq 2\pi \end{cases}$

$$\sin^{-1}(\sin x) = \begin{cases} x; 0 \leq x \leq \frac{\pi}{2} \\ \pi - x; \frac{\pi}{2} \leq x \leq 3\pi/2 \\ x - 2\pi; \frac{3\pi}{2} \leq x \leq 2\pi \end{cases}$$



$$\Rightarrow f(x) = \cos^{-1}(\cos x) - \sin^{-1}(\sin x)$$

$$= \begin{cases} 0; 0 \leq x \leq \pi/2 \\ 2x - \pi; \frac{\pi}{2} \leq x \leq \pi \\ \pi; \pi \leq x \leq 3\pi/2 \\ 4\pi - 2x; \frac{3\pi}{2} \leq x \leq 2\pi \end{cases}$$

Also  $\cos^{-1}(\cos(2\pi + x)) = \cos^{-1}(\cos x)$  and  $\sin^{-1}(\sin(2\pi + x)) = \sin^{-1}(\sin x)$

$$\Rightarrow f(2\pi + x) = f(x)$$

$\Rightarrow f(x)$  is a periodic function with period  $2\pi$ , so if we calculate area (A) bounded by  $f(x)$  and x-axis for one complete period i.e., for  $[0, 2\pi]$ , then it would be 6 times for the interval  $[-6\pi, 6\pi]$

The graph of  $f(x)$  is as shown below:

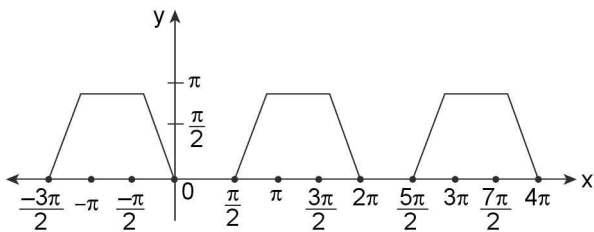

$$\therefore \text{Area bounded in } [0, 2\pi] = \frac{1}{2} \left( \frac{3\pi}{2} + \frac{\pi}{2} \right) \times (\pi) = \pi^2$$

$$\therefore \text{Area bounded in } [-6\pi, 6\pi] = 6\pi^2 \text{ square units}$$

$\therefore$  (c) is correct option

7. Solution of equation  $\cos^{-1} x\sqrt{3} + \cos^{-1} x = \frac{\pi}{2}$  is

- (a)  $x = \frac{1}{2}$                       (b)  $x = -1/2$
- (c)  $x = \pm 1/2$                       (d) None of these

**Solution:**  $\cos^{-1} x\sqrt{3} + \cos^{-1} x = \frac{\pi}{2}$  is given equation ... (i)

Now  $\cos^{-1} x\sqrt{3}, \cos^{-1} x \geq 0$  and their sum is  $\pi/2$

$$\Rightarrow \cos^{-1} x\sqrt{3}, \cos^{-1} x \text{ both must belong to } [0, \pi/2]$$

$$\Rightarrow x\sqrt{3}, x \in [0, 1]$$

$$\text{Now from (i) } \cos^{-1} x\sqrt{3} + \cos^{-1} x = \frac{\pi}{2}$$

$$\Rightarrow \cos^{-1} x\sqrt{3} = \frac{\pi}{2} - \cos^{-1} x$$

$$\Rightarrow \cos^{-1} x\sqrt{3} = \sin^{-1} x \text{ as } \sin^{-1} x + \cos^{-1} x = \pi/2$$

$$\Rightarrow \cos^{-1} x\sqrt{3} = \cos^{-1} \sqrt{1-x^2} \text{ as } \sin^{-1} x \in [0, \pi/2]$$

$$\Rightarrow x\sqrt{3} = \sqrt{1-x^2} \text{ as } \cos^{-1} x \text{ is one - one function}$$

$$3x^2 = 1 - x^2 \Rightarrow 4x^2 = 1 \Rightarrow x = \pm 1/2$$

But  $x \in [0, 1] \Rightarrow x = \frac{1}{2}$  is the only possible solution

$\Rightarrow$  (a) is the correct option

8. Solution of equation  $\tan^{-1} 2x + \tan^{-1} 3x = 3\pi/4$  is

- (a)  $x = 1, -\frac{1}{6}$                       (b)  $x = -\frac{1}{6}$
- (c)  $x = 1/6, -1$                       (d) 1

**Solution:**  $\therefore \tan^{-1} x \in \left( -\frac{\pi}{2}, \frac{\pi}{2} \right)$

$$\Rightarrow \tan^{-1} 2x, \tan^{-1} 3x \text{ both must belong to } \left[ 0, \frac{\pi}{2} \right) \text{ as}$$

otherwise their sum can never be equal to  $3\pi/4$

$$\Rightarrow 2x, 3x \geq 0 \text{ and } 3x \geq 2x \text{ and we know}$$

$$\tan^{-1} x + \tan^{-1} y$$

$$= \begin{cases} = \tan^{-1} \left( \frac{x+y}{1-xy} \right) \text{ for } xy < 1 \\ \pi + \tan^{-1} \left( \frac{x+y}{1-xy} \right) \text{ for } xy > 1 \text{ and } x > 0, y > 0 \\ -\pi + \tan^{-1} \left( \frac{x+y}{1-xy} \right) \text{ for } xy > 1 \text{ and } x < 0, y < 0 \\ \pi/2 \text{ for } xy = 1 \text{ and } x, y > 0 \\ -\pi/2 \text{ for } xy = 1 \text{ and } x, y < 0 \end{cases}$$

So let us discuss two cases:

**Case(i)**  $(2x)(3x) < 1$

$$\text{i.e., } 6x^2 < 1 \Rightarrow x \in \left( -\frac{1}{\sqrt{6}}, \frac{1}{\sqrt{6}} \right)$$

But  $x \geq 0$

$$\Rightarrow x \in \left[ 0, \frac{1}{\sqrt{6}} \right)$$

In this case we have

$$\tan^{-1} 2x + \tan^{-1} 3x = \tan^{-1} \left[ \frac{2x+3x}{1-6x^2} \right]$$

$$\Rightarrow \tan^{-1} \left( \frac{5x}{1-6x^2} \right) = \frac{3\pi}{4}$$

Which is impossible as range of  $\tan^{-1}x$  is  $\left( \frac{-\pi}{2}, \frac{\pi}{2} \right)$

**Case (ii)**  $(2x)(3x) > 1$

$$\text{i.e., } 6x^2 > 1 \Rightarrow x \in \left( -\infty, -\frac{1}{\sqrt{6}} \right) \cup \left( \frac{1}{\sqrt{6}}, \infty \right)$$

$$\text{But } x > 0 \Rightarrow x \in \left( \frac{1}{\sqrt{6}}, \infty \right)$$

$\therefore$  In this case we have

$$\tan^{-1} 2x + \tan^{-1} 3x = \tan^{-1} \left[ \frac{2x+3x}{1-6x^2} \right] + \pi = \frac{3\pi}{4}$$

$$\Rightarrow \tan^{-1} \left( \frac{5x}{1-6x^2} \right) = -\frac{\pi}{4}$$

$$\Rightarrow \left( \frac{5x}{1-6x^2} \right) = -1 \Rightarrow 6x^2 - 1 = 5x$$

$$\Rightarrow 6x^2 - 5x - 1 = 0$$

$$\Rightarrow 6x^2 - 6x + x - 1 = 0 \Rightarrow (x-1)(6x+1) = 0$$

$$\Rightarrow x = 1 \text{ or } x = -1/6 \text{ but } x \in \left( \frac{1}{\sqrt{6}}, \infty \right)$$

$\Rightarrow x = 1$  is the only possible solution

$\therefore$  (d) is correct option

### 9. Solution of equation

$$\tan^{-1} \left( \frac{x+1}{x-1} \right) + \tan^{-1} \left( \frac{x-1}{x} \right) = \tan^{-1}(-7) \text{ is}$$

- (a)  $x = 2$                       (b)  $x = 1$   
 (c)  $x \in (1, \infty)$               (d) No solution

**Solution:** Given equation is

$$\tan^{-1} \left( \frac{x+1}{x-1} \right) + \tan^{-1} \left( \frac{x-1}{x} \right) = -\tan^{-1} 7; x \neq 0, 1$$

$$\Rightarrow \text{Both } \tan^{-1} \left( \frac{x+1}{x-1} \right) \text{ and } \tan^{-1} \left( \frac{x-1}{x} \right)$$

can't belong to interval  $[0, \pi/2)$

So, let us discuss two cases:

**Case (i)**  $\left( \frac{x+1}{x-1} \right) \left( \frac{x-1}{x} \right) > 1$  and  $\frac{x+1}{x-1}; \frac{x-1}{x} > 0$

$$\Rightarrow \frac{x+1}{x} > 1 \text{ and } \frac{x+1}{x-1}, \frac{x-1}{x} > 0$$

$$\Rightarrow 1 + \frac{1}{x} > 1 \text{ and } (x+1)(x-1), (x-1)(x) > 0$$

$$\Rightarrow \frac{1}{x} > 0 \text{ and } (x+1)(x-1), (x)(x-1) > 0$$

$$\Rightarrow x > 0 \text{ and } x > 1$$

$$\Rightarrow x \in (1, \infty)$$

$$\therefore \tan^{-1} \left( \frac{x+1}{x-1} \right) + \tan^{-1} \left( \frac{x-1}{x} \right) = \tan^{-1}(-7)$$

$$\Rightarrow \pi + \tan^{-1} \left[ \frac{\frac{x+1}{x-1} + \frac{x-1}{x}}{1 - \left( \frac{x+1}{x-1} \right) \left( \frac{x-1}{x} \right)} \right] = -\tan^{-1}(7)$$

Which is impossible as L.H.S  $\in \left( \frac{\pi}{2}, \pi \right)$  i.e +ve,

whereas R.H.S is -ve

**Case (ii)**  $\left( \frac{x+1}{x-1} \right) \left( \frac{x-1}{x} \right) \geq 1$  and  $\left( \frac{x+1}{x-1} \right), \left( \frac{x-1}{x} \right) < 0$

$$\Rightarrow x > 0 \text{ and } x \in (0, 1)$$

$$\Rightarrow x \in (0, 1)$$

$$\therefore \tan^{-1} \left( \frac{x+1}{x-1} \right) + \tan^{-1} \left( \frac{x-1}{x} \right) = \tan^{-1}(-7)$$

$$\Rightarrow -\pi + \tan^{-1} \left[ \frac{\frac{x+1}{x-1} + \frac{x-1}{x}}{1 - \left( \frac{x+1}{x-1} \right) \left( \frac{x-1}{x} \right)} \right] = -\tan^{-1}(7)$$

$$\Rightarrow \tan^{-1} \left[ \frac{\frac{x+1}{x-1} + \frac{x-1}{x}}{1 - \left( \frac{x+1}{x-1} \right) \left( \frac{x-1}{x} \right)} \right] + \tan^{-1}(7) = \pi$$

$$\Rightarrow \tan^{-1} \left[ \frac{x^2 + x + x^2 + 1 - 2x}{x^2 - x - x^2 + 1} \right] + \tan^{-1}(7) = \pi$$

$$\Rightarrow \tan^{-1} \left[ \frac{2x^2 - x + 1}{1 - x} \right] + \tan^{-1}(7) = \pi$$

$$\Rightarrow \tan^{-1} \left[ \left( \frac{2x^2 - x + 1}{1 - x} \right) \right] = [\pi - \tan^{-1}(7)]$$

$$\Rightarrow \frac{2x^2 - x + 1}{1 - x} = -\tan(\tan^{-1}(7))$$

$$[\text{as } \tan(\tan^{-1} x) = x \forall x \in \mathbb{R}]$$

$$\begin{aligned} \Rightarrow \frac{2x^2 - x + 1}{1 - x} &= -7 \\ \Rightarrow 2x^2 - x + 1 &= 7x - 7 \\ \Rightarrow 2x^2 - 8x + 8 &= 0 \Rightarrow x^2 - 4x + 4 = 0 \Rightarrow (x - 2)^2 = 0 \\ \Rightarrow x &= 2, \text{ But } x \in (0, 1) \end{aligned}$$

There will be no solution of given equation

∴ (d) will be the correct option

10. Solution of equation  $\sin^{-1} x + \sin^{-1} 2x = \pi/3$  is

- (a)  $\pm \frac{1}{2}\sqrt{\frac{3}{7}}$       (b)  $x = \frac{1}{2}\sqrt{\frac{3}{7}}$   
 (c)  $\sqrt{\frac{3}{7}}$       (d) None of these

**Solution:**  $\sin^{-1} x$  and  $\sin^{-1} 2x$  both can't belong to  $\left[-\frac{\pi}{2}, 0\right]$  as otherwise L.H.S would be -ve, whereas

R.H.S is +ve

Also  $x$  and  $2x$  can't be of opposite sign

- ⇒  $x$  and  $2x$  both must be +ve  
 ⇒  $\sin^{-1} x$  and  $\sin^{-1} 2x$  both must belong  $[0, \pi/2]$   
 ⇒  $x, 2x \in [0, 1]$   
 ⇒  $x \in [0, 1/2]$

Now given equation is  $\sin^{-1} x + \sin^{-1} 2x = \pi/3$

$$\Rightarrow \sin^{-1} 2x = \sin^{-1} \frac{\sqrt{3}}{2} - \sin^{-1} x \dots (i)$$

$$\text{Now } \left(\frac{\sqrt{3}}{2}\right)^2 + x^2 < \frac{3}{4} + \frac{1}{4} \text{ as } x < \frac{1}{2}$$

$$\Rightarrow \sin^{-1} \left(\frac{\sqrt{3}}{2}\right) - \sin^{-1} x = \sin^{-1} \left[\frac{\sqrt{3}}{2}\sqrt{1-x^2} - x\sqrt{1-\frac{3}{4}}\right]$$

∴ From (i)

$$\sin^{-1} 2x = \sin^{-1} \left[\frac{\sqrt{3}}{2}\sqrt{1-x^2} - x\frac{1}{2}\right]$$

$$\Rightarrow 2x = \frac{\sqrt{3}}{2}\sqrt{1-x^2} - \frac{x}{2}$$

$$\Rightarrow \frac{5}{2}x = \frac{\sqrt{3}}{2}\sqrt{1-x^2} \Rightarrow 5x = \sqrt{3}\sqrt{1-x^2}$$

$$\Rightarrow 25x^2 = 3 - 3x^2$$

$$\Rightarrow 28x^2 = 3 \Rightarrow x = \pm \sqrt{\frac{3}{28}} = \pm \frac{\sqrt{3}}{2\sqrt{7}} = \pm \frac{1}{2}\sqrt{\frac{3}{7}}$$

But  $x \in \left[0, \frac{1}{2}\right] \Rightarrow x = \frac{1}{2}\sqrt{\frac{3}{7}}$  is the only solution of given equation

⇒ (b) is correct option

11. The value of  $x$  for which

$$f(x) = \cos^{-1} x + \cos^{-1} \left(\frac{x}{2} + \frac{\sqrt{3-3x^2}}{2}\right)$$

represents a constant function belongs to

- (a)  $\left[\frac{1}{2}, 1\right]$       (b)  $\left[0, \frac{1}{2}\right]$   
 (c)  $\left[\frac{1}{2}, \frac{1}{\sqrt{2}}\right]$       (d) None of these

$$\text{Solution: } f(x) = \cos^{-1} x + \cos^{-1} \left[\frac{x}{2} + \frac{\sqrt{3}}{2}\sqrt{1-x^2}\right]$$

$$= \cos^{-1} x + \cos^{-1} \left[x \cdot \frac{1}{2} + \sqrt{1-x^2} \sqrt{1-\left(\frac{1}{2}\right)^2}\right] \dots (i)$$

Now  $\cos^{-1} x - \cos^{-1} y$

$$= \begin{cases} \cos^{-1} (xy + \sqrt{1-x^2}\sqrt{1-y^2}) & \text{for } y - x \geq 0 \\ -\cos^{-1} (xy + \sqrt{1-x^2}\sqrt{1-y^2}) & \text{for } y - x \leq 0 \end{cases}$$

$$\begin{aligned} \Rightarrow \cos^{-1} (xy + \sqrt{1-x^2}\sqrt{1-y^2}) \\ = \cos^{-1} x - \cos^{-1} y \text{ for } x \leq y \end{aligned}$$

∴ from (i) we have

$$f(x) = \begin{cases} \cos^{-1} x + \cos^{-1} x - \cos^{-1} \frac{1}{2} & \text{for } x \leq \frac{1}{2} \\ \cos^{-1} x + \cos^{-1} \frac{1}{2} - \cos^{-1} x & \text{for } \frac{1}{2} \leq x \end{cases}$$

$$\Rightarrow f(x) = \begin{cases} 2\cos^{-1} x - \pi/3 & \text{for } x \leq \frac{1}{2} \\ \pi/3 & \text{for } x \geq \frac{1}{2} \end{cases}$$

∴  $f(x)$  would be a constant function for  $x \in \left[\frac{1}{2}, 1\right]$

∴ (a) is correct option

12. If  $(\cot^{-1} x)^2 - 5\cot^{-1} x + 6 > 0$ , then  $x$  lies in

- (a)  $(\cot 3, \cot 2)$       (b)  $(-\infty, \cot 3) \cup (\cot 2, \infty)$   
 (c)  $(\cot 2, \infty)$       (d) None of these

**Solution:** (b) We have

$$\Rightarrow (\cot^{-1}x)^2 - 5 \cot^{-1}x + 6 > 0$$

$$\therefore (\cot^{-1}x - 2)(\cot^{-1}x - 3) > 0$$

$$\Rightarrow \cot^{-1}x < 2 \text{ or } \cot^{-1}x > 3$$

As  $\cot^{-1}x$  is a decreasing function, then

$$x \in (-\infty, \cot 3) \cup (\cot 2, \infty)$$

13. If  $-1 < x < 0$ , then  $\tan^{-1}x$  equals

(a)  $\pi - \cos^{-1}(\sqrt{1-x^2})$  (b)  $\sin^{-1}\left(\frac{x}{\sqrt{1+x^2}}\right)$

(c)  $\cot^{-1}\left(\frac{\sqrt{1-x^2}}{x}\right)$  (d)  $\operatorname{cosec}^{-1}x$

**Solution:** (b)  $\because -1 < x < 0$ , then  $-\frac{\pi}{4} < \tan^{-1}x < 0$

$$\text{Let } \tan^{-1}x = \alpha \Rightarrow -\frac{\pi}{4} < \alpha < 0$$

$$\therefore \tan \alpha = x, -\pi/4 < \alpha < 0$$

$$\sin \alpha = \frac{x}{\sqrt{1+x^2}} \Rightarrow \alpha = \sin^{-1} \frac{x}{\sqrt{1+x^2}}$$

$$\cos \alpha = \frac{1}{\sqrt{1+x^2}} \Rightarrow \cos(-\alpha) = \frac{1}{\sqrt{1+x^2}}$$

where  $0 < -\alpha < \pi/4$

$$\Rightarrow \alpha = -\cos^{-1}\left(\frac{1}{\sqrt{1+x^2}}\right)$$

14. Indicate the relation which is true.

(a)  $\tan |\tan^{-1}x| = |x|$  (b)  $\cot |\cot^{-1}x| = x$

(c)  $\tan^{-1} |\tan x| = |x|$  (d)  $\sin |\sin^{-1}x| = |x|$

**Solution:** (a,b,d)

$$\text{since } |\tan^{-1}x| = \begin{cases} \tan^{-1}x & \text{if } 0 \leq \tan^{-1}x < \pi/2 \\ -\tan^{-1}x & \text{if } -\pi/2 < \tan^{-1}x < 0 \end{cases}$$

$$= \begin{cases} \tan^{-1}x & \text{if } x \geq 0 \\ -\tan^{-1}x & \text{if } x < 0 \end{cases}$$

$$\Rightarrow |\tan^{-1}x| = \tan^{-1}|x| \text{ for all } x \in \mathbb{R}$$

$$\Rightarrow \tan |\tan^{-1}x| = \tan \tan^{-1}|x| = |x|$$

Hence (a) is correct.

Likewise  $\sin |\sin^{-1}x| = \sin \sin^{-1}|x| = |x|$  for all  $|x| \leq 1$

Hence (d) is correct.

$$\cot |\cot^{-1}x| = \cot \cot^{-1}x = x$$

Hence (b) is correct.

since  $|\tan x|$  is not necessarily always equal to  $\tan |x|$

Hence  $\tan^{-1} |\tan x| \neq |x|$

15. If  $[\sin^{-1} \cos^{-1} \sin^{-1} \tan^{-1} x] = 1$ ; where  $[\cdot]$  denotes the greatest integer function, then  $x$  belongs to the interval

(a)  $[\tan \sin \cos 1, \tan \sin \cos \sin 1]$

(b)  $[\tan \sin \cos 1, \tan \sin \cos \sin 1]$

(c)  $[-1, 1]$

(d)  $[\sin \cos \tan 1, \sin \cos \sin \tan 1]$

**Solution:** (a) We have  $[\sin^{-1} \cos^{-1} \sin^{-1} \tan^{-1} x] = 1$

$$\Rightarrow 1 \leq \sin^{-1} \cos^{-1} \sin^{-1} \tan^{-1} x \leq \pi/2$$

$$\Rightarrow \sin 1 \leq \cos^{-1} \sin^{-1} \tan^{-1} x \leq 1$$

$$\Rightarrow \cos \sin 1 \geq \sin^{-1} \tan^{-1} x \geq \cos 1$$

$$\Rightarrow \sin \cos \sin 1 \geq \tan^{-1} x \geq \sin \cos 1$$

$$\Rightarrow \tan \sin \cos \sin 1 \geq x \geq \tan \sin \cos 1$$

Hence  $x \in [\tan \sin \cos 1, \tan \sin \cos \sin 1]$

16. The value of

$$\sin^{-1} \left[ \cot \left( \sin^{-1} \sqrt{\frac{2-\sqrt{3}}{4}} + \cos^{-1} \frac{\sqrt{12}}{4} + \sec^{-1} \sqrt{2} \right) \right] \text{ is}$$

(a) 0

(b)  $\pi/4$

(c)  $\pi/6$

(d)  $\pi/2$

**Solution:** (a) We have

$$\sin^{-1} \left[ \cot \left( \sin^{-1} \sqrt{\frac{2-\sqrt{3}}{4}} + \cos^{-1} \frac{\sqrt{12}}{4} + \sec^{-1} \sqrt{2} \right) \right]$$

$$= \sin^{-1} \left[ \cot \left( \sin^{-1} \left( \frac{\sqrt{3}-1}{2\sqrt{2}} \right) + \cos^{-1} \frac{\sqrt{3}}{2} + \cos^{-1} \frac{1}{\sqrt{2}} \right) \right]$$

$$= \sin^{-1} [\cot(15^\circ + 30^\circ + 45^\circ)]$$

$$= \sin^{-1} [\cot 90^\circ] = \sin^{-1} 0 = 0$$

17. If we consider only the principal values of the inverse trigonometric functions, then the value of

$$\tan \left[ \cos^{-1} \frac{1}{\sqrt{2}} - \sin^{-1} \frac{4}{\sqrt{17}} \right] \text{ is}$$

(a)  $\frac{\sqrt{29}}{3}$

(b)  $\frac{29}{3}$

(c)  $\frac{\sqrt{3}}{29}$

(d)  $-\frac{3}{5}$

4.70 > Trigonometry

**Solution:** (d)  $\cos^{-1} \frac{1}{\sqrt{2}} = \tan^{-1} 1$ ,  $\sin^{-1} \frac{4}{\sqrt{17}} = \tan^{-1} 4$

$$\begin{aligned} \text{Therefore } \tan \left[ \cos^{-1} \frac{1}{\sqrt{2}} - \sin^{-1} \frac{4}{\sqrt{17}} \right] \\ = \tan[\tan^{-1} 1 - \tan^{-1} 4] \\ = \tan \tan^{-1} \left[ \frac{1-4}{1+4} \right] = \tan \tan^{-1} \left[ -\frac{3}{5} \right] = -\frac{3}{5} \end{aligned}$$

18. If  $(\tan^{-1} x)^2 + (\cot^{-1} x)^2 = \frac{5\pi^2}{8}$ , then  $x$  equals

- (a)  $-1$  (b)  $1$   
(c)  $0$  (d) None of these

**Solution:** (a) We have  $(\tan^{-1} x)^2 + (\cot^{-1} x)^2 = \frac{5\pi^2}{8}$   
 $\Rightarrow (\tan^{-1} x + \cot^{-1} x)^2 - 2 \tan^{-1} x (\pi/2 - \tan^{-1} x) = \frac{5\pi^2}{8}$

$$\Rightarrow \frac{\pi}{4} - 2 \cdot \frac{\pi}{2} \tan^{-1} x + 2(\tan^{-1} x)^2 = \frac{\pi}{8}$$

$$\Rightarrow 2(\tan^{-1} x)^2 - \pi \tan^{-1} x - \frac{3\pi^2}{8} = 0$$

$$\Rightarrow \tan^{-1} x = -\pi/4, 3\pi/4$$

$$\Rightarrow \tan^{-1} x = -\pi/4 \Rightarrow x = -1$$

19. If  $A = 2 \tan^{-1}(2\sqrt{2} - 1)$  and  $B = 3 \sin^{-1}(1/3) + \sin^{-1}(3/5)$ , then

- (a)  $A = B$  (b)  $A < B$   
(c)  $A > B$  (d) None of these

**Solution:** (c) We have  $A = 2 \tan^{-1}(2\sqrt{2} - 1)$

$$= 2 \tan^{-1}(1.828) \Rightarrow A > 2 \tan^{-1} \sqrt{3}$$

$$\Rightarrow A > 2\pi/3$$

$$\text{We have } \sin^{-1}(1/3) < \sin^{-1}(1/2)$$

$$\Rightarrow \sin^{-1}(1/3) < \pi/6 \Rightarrow 3 \sin^{-1}(1/3) < \pi/2$$

$$\text{Also } 3 \sin^{-1}(1/3) = \sin^{-1} \left[ 3 \cdot \frac{1}{3} - 4 \left( \frac{1}{3} \right)^3 \right] =$$

$$\sin^{-1} \left( \frac{23}{27} \right) = \sin^{-1}(0.852) < \sin^{-1} \left( \frac{\sqrt{3}}{2} \right)$$

$$\Rightarrow 3 \sin^{-1}(1/3) < \sin^{-1} \left( \frac{\sqrt{3}}{2} \right)$$

$$\Rightarrow 3 \sin^{-1}(1/3) < \pi/3$$

$$\text{Also } \sin^{-1}(3/5) = \sin^{-1}(0.6) < \sin^{-1}(\sqrt{3}/2)$$

$$\Rightarrow \sin^{-1}(3/5) < \pi/3$$

Hence,

$$B = 3 \sin^{-1}(1/3) + \sin^{-1}(3/5) < \pi/3 + \pi/3 = 2\pi/3$$

Hence  $A > B$

20. If  $\sin^{-1} x > \cos^{-1} x$ , then

(a)  $x \in \left( -1, -\frac{1}{\sqrt{2}} \right)$  (b)  $x \in \left( 0, \frac{1}{\sqrt{2}} \right)$

(c)  $x \in \left( \frac{1}{\sqrt{2}}, 1 \right]$  (d)  $x \in \left( -\frac{1}{\sqrt{2}}, 0 \right)$

**Solution:** (c) We have  $\sin^{-1} x > \cos^{-1} x$

$$\Rightarrow \sin^{-1} x > \pi/2 - \sin^{-1} x$$

$$\Rightarrow 2 \sin^{-1} x > \pi/2 \Rightarrow \sin^{-1} x > \pi/4$$

$$\text{Also } \sin(\sin^{-1} x) > \sin \pi/4$$

$$\Rightarrow x > \frac{1}{\sqrt{2}} \Rightarrow x \in \left( \frac{1}{\sqrt{2}}, 1 \right], \text{ since } -1 \leq x \leq 1$$

21. The least and greatest values of  $(\sin^{-1} x)^3 + (\cos^{-1} x)^3$  are respectively

- (a)  $-\pi/2, \pi/2$  (b)  $-\pi^3/8, \pi^3/8$   
(c)  $\pi^3/32, 7\pi^3/8$  (d) None of these

**Solution:** (c)  $(\sin^{-1} x)^3 + (\cos^{-1} x)^3 =$

$$(\sin^{-1} x + \cos^{-1} x)^3 - 3 \sin^{-1} x \cos^{-1} x (\sin^{-1} x + \cos^{-1} x)$$

$$= \left( \frac{\pi}{2} \right)^3 - 3 \sin^{-1} x \cos^{-1} x \left( \frac{\pi}{2} \right)$$

$$= \frac{\pi^3}{8} - \frac{3\pi}{2} \sin^{-1} x \left( \frac{\pi}{2} - \sin^{-1} x \right)$$

$$= \frac{\pi^3}{8} - \frac{3\pi^2}{4} \sin^{-1} x + \frac{3\pi}{2} (\sin^{-1} x)^2$$

$$= \frac{\pi^3}{8} + \frac{3\pi}{2} \left[ (\sin^{-1} x)^2 - \frac{\pi}{2} \sin^{-1} x \right]$$

$$= \frac{\pi^3}{8} + \frac{3\pi}{2} \left[ \left( \sin^{-1} x - \frac{\pi}{4} \right)^2 \right] - \frac{3\pi^3}{32}$$

$$= \frac{\pi^3}{32} + \frac{3\pi}{2} \left( \sin^{-1} x - \frac{\pi}{4} \right)^2$$

$\Rightarrow$  The least value is  $\frac{\pi^3}{32}$  and since

$$\left( \sin^{-1} x - \frac{\pi}{4} \right)^2 \leq \left( \frac{3\pi}{4} \right)^2$$

$$\Rightarrow \text{The greatest value is } \frac{\pi^3}{32} + \frac{9\pi^2}{16} \times \frac{3\pi}{2} = \frac{7\pi^3}{8}$$

## SECTION-II

### SUBJECTIVE SOLVED EXAMPLES

1. Solve the following equations for  $x \geq 0$

- (i)  $[\sin^{-1}x] + [\cos^{-1}x] = 0$
- (ii)  $[\sin^{-1}x] + [\cos^{-1}x] = 1$
- (iii)  $[\sin^{-1}x] + [\cos^{-1}x] = 2$

**Solution:**  $\sin^{-1}x \in [0, \pi/2]$  &  $\cos^{-1}x \in [0, \pi/2]$  for  $x \geq 0$

$\therefore [\sin^{-1}x] \in \{0, 1\}$  and  $[\cos^{-1}x] \in \{0, 1\}$

(i)  $[\sin^{-1}x] + [\cos^{-1}x] = 0 \Rightarrow [\sin^{-1}x] = [\cos^{-1}x] = 0$   
 $\Rightarrow \sin^{-1}x \in [0, 1)$  and  $\cos^{-1}x \in [0, 1)$

$\Rightarrow x \in [\sin 0, \sin 1)$  and  $x \in (\cos 1, \cos 0]$

$\Rightarrow x \in [0, \sin 1) \cap (\cos 1, 1]$

$\Rightarrow x \in (\cos 1, \sin 1)$

[as  $0 < \cos 1 < \sin 1 < 1$ ]

(ii)  $[\sin^{-1}x] + [\cos^{-1}x] = 1$

$\Rightarrow [\sin^{-1}x] = 1; [\cos^{-1}x] = 0$

$\Rightarrow [\sin^{-1}x] = 0; [\cos^{-1}x] = 1$

$\Rightarrow \sin^{-1}x \in [1, \frac{\pi}{2}]$ ;  $\cos^{-1}x \in [0, 1)$

or  $\sin^{-1}x \in [0, 1)$ ;  $\cos^{-1}x \in [1, \frac{\pi}{2}]$

$\Rightarrow x \in [\sin 1, 1]; (\cos 1, 1]$

or  $x \in [0, \sin 1)$ ;  $x \in [0, \cos 1]$

$\Rightarrow x \in [\sin 1, 1] \cap (\cos 1, 1]$  or  $x \in [0, \sin 1) \cap [0, \cos 1]$

$\Rightarrow x \in [\sin 1, 1] \cup [0, \cos 1]$  Ans

(iii)  $[\sin^{-1}x] + [\cos^{-1}x] = 2$

$\Rightarrow [\sin^{-1}x] = [\cos^{-1}x] = 1$

$\Rightarrow \sin^{-1}x \in [1, \frac{\pi}{2}]$ ;  $\cos^{-1}x \in [1, \frac{\pi}{2}]$

$\Rightarrow x \in [\sin 1, 1]; x \in [0, \cos 1]$

$\Rightarrow x \in [0, \cos 1] \cap [\sin 1, 1] = \phi$

2. Find the total number of solutions of  $\tan\{x\} = \cot\{x\}$ ; where  $\{x\}$  denotes the fractional part of  $x$  in  $[0, 2\pi]$

**Solution:**  $\tan\{x\} = \cot\{x\} \Rightarrow \{x\} \geq 0$

$\Rightarrow \frac{\tan\{x\}}{\cot\{x\}} = 1 \Rightarrow \tan^2\{x\} = 1$

$\Rightarrow \tan^2\{x\} = 1 \Rightarrow \tan\{x\} = \pm 1$

But  $\{x\} \leq [0, 1) \Rightarrow \tan\{x\} \neq 0$

$\Rightarrow \tan\{x\} \neq -1 \therefore \tan\{x\} = 1$

$\Rightarrow \{x\} = \tan^{-1}1 = \pi/4 \dots\dots\dots(i)$

But  $x \leq [0, 2\pi]$

$\therefore$  Clearly, (i) holds where graph of  $y = \{x\}$  and  $y = \pi/4$  intersect each other in  $[0, 2\pi]$  which are 6 points as shown below in diagram

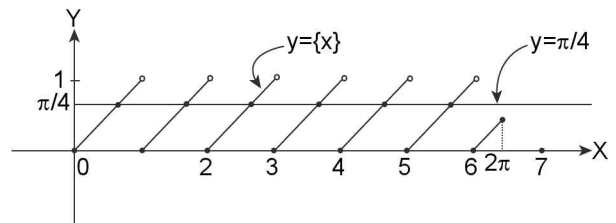

3. Solve the system of inequalities  $\cos^{-1}x > \sin^{-1}x$  and  $\cos^{-1}x > \cos^{-1}(1-x)$ .

**Solution:**  $\cos^{-1}x > \sin^{-1}x$  for  $x \leq [-1, \frac{1}{\sqrt{2}}) \dots\dots(i)$

and  $\cos^{-1}x$  is a decreasing function so,  $\cos^{-1}x > \cos^{-1}(1-x)$

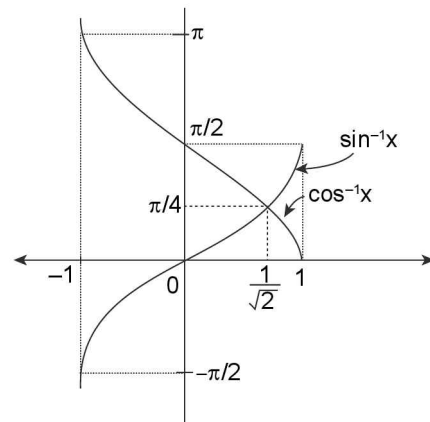

$\Rightarrow x < 1-x \Rightarrow 2x < 1 \Rightarrow x < 1/2 \dots\dots(ii)$

Also  $-1 \leq 1-x \leq 1$

$\Rightarrow -2 \leq -x \leq 0 \Rightarrow 2 \geq x \geq 0$

$\therefore x \in [0, 2]$  Also  $x \in [-1, 1] \Rightarrow x \in [0, 1] \dots\dots(iii)$

From (i), (ii) and (iii), we must have,  $x \in [0, \frac{1}{2}]$  **Ans**

4.72 > Trigonometry

4. Solve the inequality  $\operatorname{cosec}^{-1} 20x - \sec^{-1}(-20x) < \pi x$

**Solution:**  $\operatorname{cosec}^{-1} 20x - \sec^{-1}(-20x) < \pi x$   
 $\Rightarrow \operatorname{cosec}^{-1}(20x) - [\pi - \sec^{-1}(20x)] < \pi x$   
 $\Rightarrow \operatorname{cosec}^{-1}(20x) + \sec^{-1}(20x) - \pi < \pi x$   
 $\Rightarrow \frac{\pi}{2} - \pi < \pi x \Rightarrow -\frac{\pi}{2} < \pi x \Rightarrow x > -\frac{1}{2}$   
 $\Rightarrow x \in \left(-\frac{1}{2}, \infty\right)$

Also  $20x \leq -1$  or  $20x \geq 1$

$\Rightarrow x \leq \frac{-1}{20}$  or  $x \geq \frac{1}{20}$

$\therefore x \in \left(-\frac{1}{2}, \infty\right) \cap \left\{ \left(-\infty, -\frac{1}{20}\right] \cup \left[\frac{1}{20}, \infty\right) \right\}$

$= \left(-\frac{1}{2}, \frac{-1}{20}\right] \cup \left[\frac{1}{20}, \infty\right)$  **Ans**

5. Solve the equations

$\sin^{-1} x + \cos^{-1}(x-2) + \sin^{-1} x^2 = 2\pi$

**Solution:**  $\sin^{-1} x \in \left[-\frac{\pi}{2}, \frac{\pi}{2}\right]$ ;  $\cos^{-1}(x-2) \in [0, \pi]$

and  $\sin^{-1} x^2 \in \left[0, \frac{\pi}{2}\right]$

$\therefore \sin^{-1} x + \cos^{-1}(x-2) + \sin^{-1} x^2 \leq 2\pi$

$\Rightarrow \sin^{-1} x = \frac{\pi}{2}$ ;  $\cos^{-1}(x-2) = \pi$ ;  $\sin^{-1} x^2 = \frac{\pi}{2}$

$\Rightarrow x = 1$ ;  $x-2 = -1$ ;  $x^2 = 1$

$\Rightarrow x = 1$ ;  $x = 1$ ;  $x = \pm 1$

$\Rightarrow x = 1$

6. Solve the system of simultaneous equations

$\operatorname{cosec}^{-1}(x+y) - \sec^{-1}(y+z) = \frac{\pi}{2}$

$\sec^{-1}(y-x) + \operatorname{cosec}^{-1}(y+z) = 3\pi/2$

**Solution:** The range of  $\sec^{-1}x = [0, \pi] \sim \left\{\frac{\pi}{2}\right\}$  and

range of  $\operatorname{cosec}^{-1}x = \left[-\frac{\pi}{2}, \frac{\pi}{2}\right] \sim \{0\}$

We must have  $\operatorname{cosec}^{-1}(x+y) = \frac{\pi}{2}$ ;  $\sec^{-1}(y+z) = 0$

and  $\sec^{-1}(y-x) = \pi$ ;  $\operatorname{cosec}^{-1}(y+z) = \frac{\pi}{2}$

$\Rightarrow x+y=1$ ;  $y+z=1$ ;  $y-x=-1$ ;  $y+z=1$

$\Rightarrow x=1, y=0, z=1$

7. Find the domain of the function

$f(x) = \ln\left(\frac{5 \tan^{-1} x + 2\pi}{-2 \tan^{-1} x + \pi}\right)$

**Solution:**  $\frac{5 \tan^{-1} x + 2\pi}{-2 \tan^{-1} x + \pi} > 0$

$\Rightarrow (5 \tan^{-1} x + 2\pi)(-2 \tan^{-1} x + \pi) > 0$

$\Rightarrow (5 \tan^{-1} x + 2\pi)(2 \tan^{-1} x - \pi) < 0$

$\Rightarrow -\frac{2\pi}{5} < \tan^{-1} x < \frac{\pi}{2}$

$\Rightarrow \tan^{-1} x \in \left(-\frac{2\pi}{5}, \frac{\pi}{2}\right) \subset \left(-\frac{\pi}{2}, \frac{\pi}{2}\right)$

in which  $\tan^{-1} x$  is an increasing function

$\Rightarrow x \in \left(-\tan \frac{2\pi}{5}, \tan \frac{\pi}{2}\right)$

$\Rightarrow x \in \left(-\tan \frac{2\pi}{5}, \infty\right)$

8. Solve the inequalities

(a)  $\cos^{-1} 3x \geq \sin^{-1} 2x$

(b)  $\tan^{-1} 5x \leq \cot^{-1} 2x$

(c)  $\tan^{-1} 2x > \sin^{-1} 3x$

**Solution: (a)**  $\cos^{-1} 3x \geq \sin^{-1} 2x \dots\dots\dots (1)$

$3x \in [-1, 1]$ ;  $2x \in [-1, 1]$

$\Rightarrow x \in \left[-\frac{1}{3}, \frac{1}{3}\right]$ ;  $x \in \left[-\frac{1}{2}, \frac{1}{2}\right]$

$\Rightarrow x \in \left[-\frac{1}{3}, \frac{1}{3}\right]$

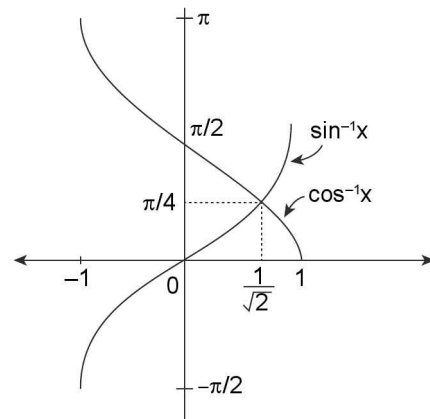

$$\text{Case (i)} \quad 0 \leq x \leq \frac{1}{3} \Rightarrow 0 \leq 3x \leq 1 \Rightarrow \cos^{-1} 3x \in \left[0, \frac{\pi}{2}\right]$$

$$\text{Also } 0 \leq 2x \leq \frac{2}{3} \Rightarrow \sin^{-1} 2x \in \left[0, \frac{\pi}{2}\right]$$

$$\Rightarrow \sin^{-1} 2x = \cos^{-1} \sqrt{1-4x^2}$$

$$\text{From (1)} \quad \cos^{-1} 3x \geq \cos^{-1} \sqrt{1-4x^2}$$

$$\Rightarrow 3x \leq \sqrt{1-4x^2} \Rightarrow 9x^2 \leq 1-4x^2 \Rightarrow 13x^2 \leq 1$$

$$\Rightarrow x^2 \leq \frac{1}{13} \Rightarrow x \in \left[\frac{-1}{\sqrt{13}}, \frac{1}{\sqrt{13}}\right]$$

$$\text{But } x \in \left[0, \frac{1}{3}\right] \Rightarrow x \in \left[0, \frac{1}{\sqrt{13}}\right]$$

$$\text{Case (ii)} \quad \frac{-1}{3} \leq x \leq 0$$

$$\Rightarrow -1 \leq 3x \leq 0; \frac{-2}{3} \leq 2x \leq 0$$

$$\Rightarrow \cos^{-1} 3x \in \left[\frac{\pi}{2}, \pi\right] \text{ and } \sin^{-1} 2x \in \left[\frac{-\pi}{2}, 0\right]$$

$$\therefore \sin^{-1} 2x = -\cos^{-1} \sqrt{1-4x^2}$$

$$\therefore \text{ from (1)} \quad \cos^{-1} 3x \geq -\cos^{-1} \sqrt{1-4x^2} \quad \dots\dots(2)$$

which is always true as  $\cos^{-1} 3x$  and  $\cos^{-1} \sqrt{1-4x^2}$  are always non-negative  
 $\Rightarrow$  L.H.S.  $\geq 0$  and R.H.S.  $\leq 0$

$\therefore$  (2) always hold

$$\therefore \text{ Final solution is } x \in \left[\frac{-1}{3}, 0\right] \cup \left[0, \frac{1}{\sqrt{13}}\right]$$

$$= \left[\frac{-1}{3}, \frac{1}{\sqrt{13}}\right]$$

$$(b) \quad \tan^{-1} 5x \leq \cot^{-1} 2x \dots(1)$$

**Case (i)** for  $x > 0$

$$\cot^{-1} 2x = \tan^{-1} \left(\frac{1}{2x}\right)$$

$\therefore$  (1) becomes

$$\tan^{-1} 5x \leq \tan^{-1} \left(\frac{1}{2x}\right)$$

$$\Rightarrow 5x \leq \frac{1}{2x} \Rightarrow 10x^2 \leq 1 \Rightarrow x^2 \leq \frac{1}{10}$$

$$\Rightarrow x \in \left(0, \frac{1}{\sqrt{10}}\right)$$

**Case (ii)** For  $x < 0$

$$\cot^{-1} 2x = \pi + \tan^{-1} \left(\frac{1}{2x}\right)$$

$$\therefore \text{ (1) becomes } \tan^{-1} 5x \leq \pi + \tan^{-1} \left(\frac{1}{2x}\right) \dots(2)$$

$$\therefore \tan^{-1} \left(\frac{1}{2x}\right) \in \left(\frac{-\pi}{2}, 0\right) \Rightarrow \pi + \tan^{-1} \left(\frac{1}{2x}\right) \in \left(\frac{\pi}{2}, \pi\right)$$

$$\text{and } \tan^{-1}(5x) \in \left(\frac{-\pi}{2}, 0\right)$$

$\therefore$  Clearly, L.H.S of (2) is less than R.H.S of (2)

$\therefore$  (2) holds for all  $x < 0$

But  $x = 0$ , clearly satisfies the inequality, thus

$$\therefore \text{ Final solution is } x \in \left(-\infty, \frac{1}{\sqrt{10}}\right) \sim \{0\}$$

$$(c) \quad \tan^{-1} 2x > \sin^{-1} 3x \quad \dots\dots(1)$$

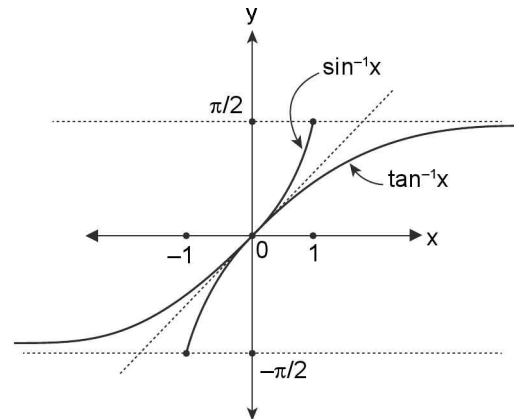

$$\text{For inequality (1), } 3x \leq [-1, 1] \Rightarrow x \leq \left[-\frac{1}{3}, \frac{1}{3}\right]$$

$$\text{Also (i) does not hold for } x=0; \Rightarrow x \in \left[-\frac{1}{3}, 0\right) \cup \left(0, \frac{1}{3}\right]$$

**Case (i)** For  $x \in \left(0, \frac{1}{3}\right]$

$$\sin^{-1} 3x = \tan^{-1} \left(\frac{3x}{\sqrt{1-9x^2}}\right)$$

$$\therefore \text{ (i) becomes } \tan^{-1} 2x > \tan^{-1} \left(\frac{3x}{\sqrt{1-9x^2}}\right)$$

$$\Rightarrow 2x > \frac{3x}{\sqrt{1-9x^2}} \quad (\because \tan^{-1} x \text{ is increasing})$$

$$\Rightarrow 2\sqrt{1-9x^2} > 3 \quad (\because x > 0)$$

$$\Rightarrow 4(1-9x^2) > 9$$



4.74 > Trigonometry

$$\Rightarrow 1 - 9x^2 > \frac{9}{4} \Rightarrow 9x^2 < 1 - \frac{9}{4} \Rightarrow 9x^2 < -\frac{5}{4}$$

which is never true.

**Case (ii)** For  $x \in \left[-\frac{1}{3}, 0\right]; \tan^{-1}(2x) \in \left(-\frac{\pi}{2}, 0\right)$

and  $\sin^{-1} 3x \in \left(-\frac{\pi}{2}, 0\right)$

(1) can be written as  $\tan^{-1}(-2x) < \sin^{-1}(-3x)$  ..... (2)

Now  $\sin^{-1}(-3x)$  and  $\tan^{-1}(-2x) \in \left(0, \frac{\pi}{2}\right)$

and  $\sin^{-1}(-3x) = \tan^{-1}\left(\frac{-3x}{\sqrt{1-9x^2}}\right)$

$\therefore$  (2) becomes,

$$\tan^{-1}(-2x) < \tan^{-1}\left(\frac{-3x}{\sqrt{1-9x^2}}\right)$$

$$\Rightarrow -2x < \frac{-3x}{\sqrt{1-9x^2}} \Rightarrow 2x > \frac{3x}{\sqrt{1-9x^2}}$$

$$\Rightarrow 2 < \frac{3}{\sqrt{1-9x^2}} \text{ (as } x < 0)$$

$$\Rightarrow 4 < \frac{9}{(1-9x^2)} \Rightarrow 4 - 36x^2 < 9$$

$$\Rightarrow 36x^2 > -5$$

which is always true

$$\Rightarrow x \in \left[\frac{-1}{3}, 0\right)$$

$\therefore$  Final solution is  $\left[\frac{-1}{3}, 0\right)$

9. Solve the inequality

$$\cot\left(\cos^{-1}\frac{x}{2}\right) \leq \sin\left(\tan^{-1}\frac{1}{3}\right)$$

**Solution:** For the domain of given inequality

$$\frac{x}{2} \in [-1, 1]$$

$$\Rightarrow x \in [-2, 2] \quad \dots\dots (1)$$

**Case (i)**  $-2 \leq x < 0$

$$\therefore -1 \leq \frac{x}{2} < 0$$

$$\Rightarrow \cos^{-1}\left(\frac{x}{2}\right) \in \left(\frac{\pi}{2}, \pi\right]$$

$$\therefore \cos^{-1}\left(\frac{x}{2}\right) = \cot^{-1}\left[\frac{x}{\sqrt{4-x^2}}\right]$$

$\therefore$  we have

$$\cot\left(\cot^{-1}\left(\frac{x}{\sqrt{4-x^2}}\right)\right) \leq \sin\left[\sin^{-1}\left(\frac{1}{\sqrt{10}}\right)\right]$$

$$\Rightarrow \frac{x}{\sqrt{4-x^2}} \leq \frac{1}{\sqrt{10}} \Rightarrow \sqrt{10}x \leq \sqrt{4-x^2}$$

which is always true as L.H.S.  $< 0$  and

R.H.S.  $\geq 0$

**Case (ii)**  $0 \leq x \leq 2$

$$\Rightarrow 0 \leq \frac{x}{2} \leq 1 \Rightarrow \cos^{-1}\frac{x}{2} \in \left[0, \frac{\pi}{2}\right]$$

$$\Rightarrow \cos^{-1}\left(\frac{x}{2}\right) = \cot^{-1}\left(\frac{x}{\sqrt{4-x^2}}\right)$$

$\therefore$  we have  $\cot\left(\cot^{-1}\left(\frac{x}{\sqrt{4-x^2}}\right)\right) \leq \sin\left[\sin^{-1}\frac{1}{\sqrt{10}}\right]$

$$\Rightarrow \frac{x}{\sqrt{4-x^2}} \leq \frac{1}{\sqrt{10}} \Rightarrow \sqrt{10}x \leq \sqrt{4-x^2}$$

$$\Rightarrow 10x^2 \leq 4 - x^2 \Rightarrow 11x^2 \leq 4 \Rightarrow x^2 \leq \frac{4}{11}$$

$$\Rightarrow x \in \left[-\frac{2}{\sqrt{11}}, \frac{2}{\sqrt{11}}\right] \cap [0, 2] = \left[0, \frac{2}{\sqrt{11}}\right]$$

$\therefore$  Final solution is

$$x \in [-2, 0) \cup \left[0, \frac{2}{\sqrt{11}}\right] = \left[-2, \frac{2}{\sqrt{11}}\right]$$

10. Prove that

$$\sin(\tan^{-1}(\cos(\sin^{-1} x))) = \sqrt{\frac{1-x^2}{2-x^2}} \quad \forall x \in [-1, 1].$$

**Solution: Case (i)** Let  $1 \geq x \geq 0$

$$\Rightarrow \sin^{-1} x \in \left[0, \frac{\pi}{2}\right]$$

let  $\sin^{-1} x = \theta$

$$\Rightarrow \cos \theta = \sqrt{1-x^2} \Rightarrow \theta = \cos^{-1} \sqrt{1-x^2}$$

$$\Rightarrow \sin^{-1} x = \cos^{-1} \sqrt{1-x^2} \Rightarrow \cos(\sin^{-1} x) = \sqrt{1-x^2}$$

$$\therefore \tan^{-1}(\cos(\sin^{-1} x))$$

$$= \tan^{-1} \sqrt{1-x^2} = \sin^{-1}\left(\frac{\sqrt{1-x^2}}{\sqrt{2-x^2}}\right)$$

$$\therefore \sin[\tan^{-1}(\cos(\sin^{-1} x))] = \sin\left[\sin^{-1}\sqrt{\frac{1-x^2}{2-x^2}}\right]$$

$$= \sqrt{\frac{1-x^2}{2-x^2}} \left( \because \sqrt{\frac{1-x^2}{2-x^2}} \in \left[0, \frac{1}{\sqrt{2}}\right] \right)$$

$$\therefore \sin(\tan^{-1}(\cos(\sin^{-1}x))) = \sqrt{\frac{1-x^2}{2-x^2}}$$

**Case (ii)** Let  $-1 \leq x < 0$

$$\sin^{-1}x \in \left[-\frac{\pi}{2}, 0\right)$$

$$\therefore \cos(\sin^{-1}x) = \cos[-\sin^{-1}x] = \cos[\sin^{-1}(-x)]$$

$$= \cos\left[\cos^{-1}\sqrt{1-(-x)^2}\right]$$

$$= \cos\left[\cos^{-1}\sqrt{1-x^2}\right] = \sqrt{1-x^2}$$

$$\Rightarrow \tan^{-1}(\cos(\sin^{-1}x))$$

$$= \tan^{-1}\sqrt{1-x^2} = \sin^{-1}\left[\frac{\sqrt{1-x^2}}{\sqrt{2-x^2}}\right]$$

$$\Rightarrow \sin[\tan^{-1}(\cos(\sin^{-1}x))]$$

$$= \sin\left[\sin^{-1}\frac{\sqrt{1-x^2}}{\sqrt{2-x^2}}\right] = \sqrt{\frac{1-x^2}{2-x^2}}$$

$$\therefore \sin(\tan^{-1}(\cos(\sin^{-1}x))) = \sqrt{\frac{1-x^2}{2-x^2}} \forall x \in [-1, 1].$$

**11.** Prove that

$$\tan\left(\frac{3\pi}{4} + \cos^{-1}\left(\frac{a}{b}\right)\right) +$$

$$\tan\left(\frac{3\pi}{4} - \cos^{-1}\left(\frac{a}{b}\right)\right) = \frac{2b^2}{b^2 - 2a^2}$$

**Solution:**

$$\tan\left[\pi - \left(\frac{\pi}{4} - \cos^{-1}\left(\frac{a}{b}\right)\right)\right] + \tan\left[\pi - \left(\frac{\pi}{4} + \cos^{-1}\left(\frac{a}{b}\right)\right)\right]$$

$$= -\tan\left[\frac{\pi}{4} - \cos^{-1}\left(\frac{a}{b}\right)\right] - \tan\left[\frac{\pi}{4} + \cos^{-1}\left(\frac{a}{b}\right)\right]$$

$$\text{Let } \cos^{-1}\left(\frac{a}{b}\right) = \theta \Rightarrow \cos\theta = \frac{a}{b}$$

$$\therefore \text{L.H.S.} = -\tan\left(\frac{\pi}{4} - \theta\right) - \tan\left(\frac{\pi}{4} + \theta\right)$$

$$= -\left[\frac{1 - \tan\theta}{1 + \tan\theta} + \frac{1 + \tan\theta}{1 - \tan\theta}\right]$$

$$= -\left[\frac{(1 - \tan\theta)^2 + (1 + \tan\theta)^2}{1 - \tan^2\theta}\right]$$

$$= -\left[\frac{2 \tan^2\theta + 2}{1 - \tan^2\theta}\right] = \frac{-2(1 + \tan^2\theta)}{(1 - \tan^2\theta)} = \frac{-2}{\cos 2\theta}$$

$$= \frac{-2}{2 \cos^2\theta - 1} = \frac{2}{1 - 2 \cos^2\theta}$$

$$= \frac{2}{1 - 2\left(\frac{a}{b}\right)^2} = \frac{2b^2}{b^2 - 2a^2} = \text{R.H.S.}$$

**12.** Solve for  $x$ ,  $[\sin^{-1} \sin^{-1} \cos^{-1} \cos^{-1} \cot^{-1}x] = 1$ ; where  $[\cdot]$  is gint function.

**Solution:**  $[\sin^{-1} \sin^{-1} \cos^{-1} \cos^{-1} \cot^{-1}x] = 1$

$$1 \leq \sin^{-1} \sin^{-1} \cos^{-1} \cos^{-1} \cot^{-1}x < \frac{\pi}{2}$$

$$\sin 1 \leq \sin^{-1} \cos^{-1} \cos^{-1} \cot^{-1}x < 1$$

$$\sin(\sin 1) \leq \cos^{-1} \cos^{-1} \cot^{-1}x < \sin 1$$

$$\cos(\sin(\sin 1)) \geq \cot^{-1}x > \cos(\sin 1)$$

$$\cos(\cos(\sin(\sin 1))) \leq \cot^{-1}x < \cos(\cos(\sin 1))$$

$$\cot \cos \cos \sin \sin 1 \geq x > \cot \cos \cos \sin 1$$

$$\therefore x \in (\cot \cos \cos \sin 1, \cot \cos \cos \sin \sin 1]$$

**13.** Find the number of ordered pairs of  $(x, y)$  which satisfy the following simultaneous equations.

(i)  $y = |\cos x|$  and  $y = \cos^{-1}(\cos x)$ ;  $x \in [-4\pi, 4\pi]$

(ii)  $y = |\sin x|$  and  $y = \sin^{-1}(\sin x)$ ;  $x \in [-2\pi, 2\pi]$

(iii)  $y = \sin^{-1}(\sin x)$  and  $y = (\cos x)$ ;  $x \in [-6\pi, 6\pi]$

(iv)  $y = \tan^{-1}(\tan x)$  and  $y = |\sin x|$ ;  $x \in [-9\pi, 9\pi]$

**Solution:** (i) Graph of  $y = \cos^{-1}(\cos x)$  and  $y = |\cos x|$  are as shown below.

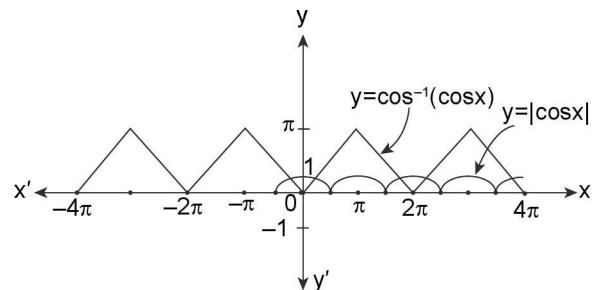

Clearly, in  $[0, 2\pi]$ ;  $y = \cos^{-1}(\cos x)$  and  $y = |\cos x|$  intersect each other twice, thus in  $[-4\pi, 4\pi]$ ; they would intersect at 8 points giving 8 ordered pairs of solutions.

(ii) Graph of  $y = \sin^{-1}(\sin x)$  and  $y = |\sin x|$  are as shown below:

4.76 > Trigonometry

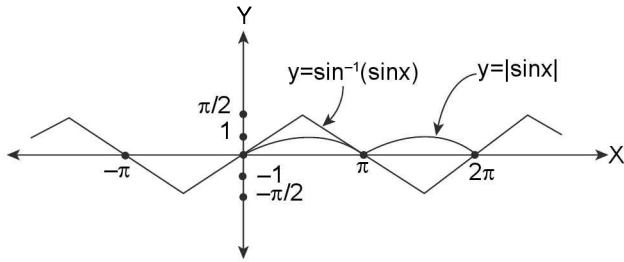

Clearly, the two graphs  $y = \sin^{-1}(\sin x)$  and  $y = |\sin x|$  intersect each other at  $n\pi, \forall n \in \mathbb{Z}$

$\therefore$  Total number of ordered pairs  $(x, y)$  satisfying the two given equations in  $[-2\pi, 2\pi]$  will be 5  
i.e.,  $(-2\pi, 0); (-\pi, 0); (0, 0); (\pi, 0); (2\pi, 0)$

(iii) Graphs of  $y = \sin^{-1}(\sin x)$  and  $y = \cos x$  are as shown below

Clearly, the two graphs intersect each other at two points in  $[0, 2\pi]$ , thus in  $[-6\pi, 6\pi]$ , there will be 12 ordered pairs  $(x, y)$  of solutions.

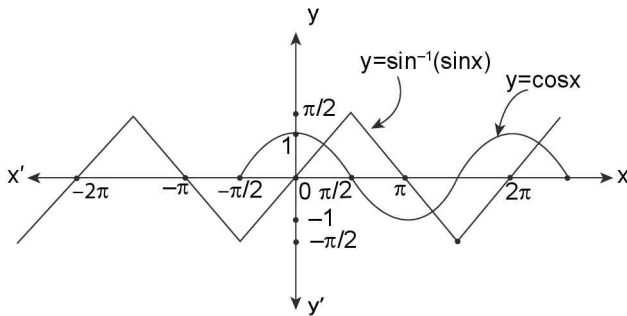

(iv) Graph of  $y = \tan^{-1}(\tan x)$  and  $y = |\sin x|$  are as shown below:

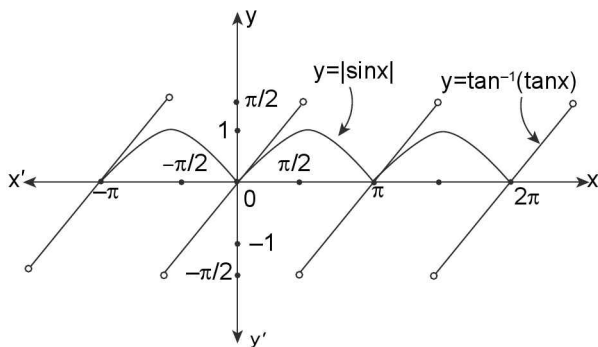

The two graphs intersect each other at each point  $x = n\pi; n \in \mathbb{Z}$ . Thus total number of ordered pairs  $(x, y)$  satisfying the given two equations in  $[-9\pi, 9\pi]$  will be 19.

14. Solve the inequality  $\tan^{-1}(\tan 3x) \leq \frac{\pi}{4} - 3x, |x| \leq \frac{\pi}{3}$ .

**Solution:**

Let  $3x = t$

$$\Rightarrow |t| \leq \pi \text{ as } |x| \leq \frac{\pi}{3}$$

$$\Rightarrow t \in [-\pi, \pi] \sim \left\{ \frac{-\pi}{2}, \frac{\pi}{2} \right\}$$

$$\therefore \tan^{-1}(\tan t) \leq \frac{\pi}{4} - t \dots (1)$$

Clearly, (1) holds when graph of  $y = \tan^{-1}(\tan t)$  is below the graph of  $y = \frac{\pi}{4} - t$

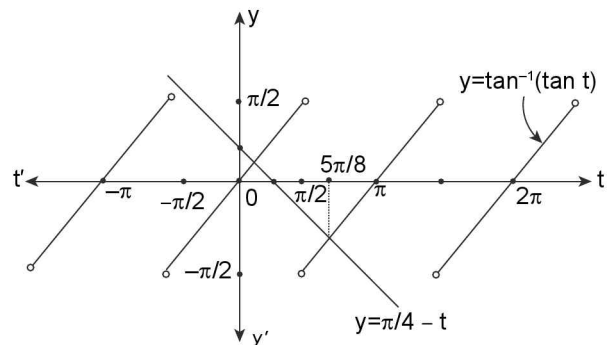

$$\Rightarrow t \in \left[ -\pi, -\frac{\pi}{2} \right) \cup \left( -\frac{\pi}{2}, \frac{\pi}{8} \right] \cup \left( \frac{\pi}{2}, \frac{5\pi}{8} \right]$$

$$\Rightarrow x \in \left[ \frac{-\pi}{3}, \frac{-\pi}{6} \right) \cup \left( \frac{-\pi}{6}, \frac{\pi}{24} \right] \cup \left( \frac{\pi}{6}, \frac{5\pi}{24} \right]$$

15. Find the area bounded by  $g(x) = \cos^{-1}(\cos x)$  and  $f(x) = \sin^{-1}(\sin x) - \cos^{-1}(\cos x)$  for  $x \in [0, 2\pi]$ .

$$\text{Solution: } \sin^{-1}(\sin x) = \begin{cases} x & \text{for } 0 \leq x \leq \pi/2 \\ \pi - x & \text{for } \pi/2 \leq x \leq 3\pi/2 \\ x - 2\pi & \text{for } 3\pi/2 \leq x \leq 2\pi \end{cases}$$

$$\text{and } \cos^{-1}(\cos x) = \begin{cases} x & \text{for } 0 \leq x \leq \pi \\ 2\pi - x & \text{for } \pi \leq x \leq 2\pi \end{cases}$$

$$\therefore f(x) = \begin{cases} 0 & \text{for } 0 \leq x \leq \frac{\pi}{2} \\ \pi - 2x & \text{for } \frac{\pi}{2} \leq x \leq \pi \\ -\pi & \text{for } \pi \leq x \leq 3\pi/2 \\ 2x - 4\pi & \text{for } \frac{3\pi}{2} \leq x \leq 2\pi \end{cases}$$

∴ Graph of  $f(x)$  is as shown below

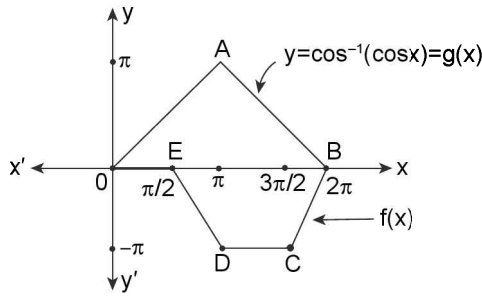

∴ Area bounded by  $f(x)$  and  $g(x) = \cos^{-1}(\cos x)$  = Area of  $\triangle OAB$  + area of trapezium EDCB

$$\begin{aligned} &= \frac{1}{2}(2\pi \times \pi) + \frac{1}{2}\left(\frac{3\pi}{2} + \frac{\pi}{2}\right) \times \pi \\ &= \pi^2 + \pi^2 = 2\pi^2 \text{ Sq. units} \end{aligned}$$

16. Evaluate the sum of series  $\sum \cot^{-1}(2\lambda^{-1} + \lambda) + \cot^{-1}(2\lambda^{-1} + 3\lambda) + \cot^{-1}(2\lambda^{-1} + 6\lambda) + \cot^{-1}(2\lambda^{-1} + 10\lambda) + \dots$  up to  $n$ -terms and hence evaluate the sum up to infinite terms for  $\lambda > 0$ .

**Solution:** ( $T_n$ ) =  $n$ th terms of series is

$$\begin{aligned} \cot^{-1}\left(2\lambda^{-1} + \frac{n(n+1)}{2}\lambda\right) &= \cot^{-1}\left[\frac{2}{\lambda} + \frac{n(n+1)}{2}\lambda\right] \\ &= \cot^{-1}\left[\frac{4 + n(n+1)\lambda^2}{2\lambda}\right] \\ &= \tan^{-1}\left[\frac{2\lambda}{4 + n(n+1)\lambda^2}\right] \left[\because \cot^{-1}x = \tan^{-1}\frac{1}{x} \text{ for } x > 0\right] \\ &= \tan^{-1}\left[\frac{\lambda/2}{1 + \frac{n}{2}\lambda \cdot \frac{(n+1)}{2}\lambda}\right] \\ &= \tan^{-1}\left[\frac{\frac{(n+1)}{2}\lambda - \frac{n}{2}\lambda}{1 + \left(\frac{(n+1)}{2}\right)\lambda \cdot \left(\frac{n}{2}\right)\lambda}\right] \\ &= \tan^{-1}\left[\frac{n+1}{2}\lambda\right] - \tan^{-1}\left[\frac{n}{2}\lambda\right] \\ &\left[\because \tan^{-1}(x) - \tan^{-1}(y) = \tan^{-1}\left(\frac{x-y}{1+xy}\right) \text{ for } xy > -1\right] \\ \therefore \sum_{k=1}^n T_k &= \sum_{k=1}^n \tan^{-1}\left(\frac{k+1}{2}\lambda\right) - \tan^{-1}\left(\frac{k}{2}\lambda\right) \end{aligned}$$

$$= \tan^{-1}\left(\frac{n+1}{2}\lambda\right) - \tan^{-1}\frac{\lambda}{2}$$

$$\text{For } n \rightarrow \infty, s_\infty = \tan^{-1}\infty - \tan^{-1}\frac{\lambda}{2} = \frac{\pi}{2} - \tan^{-1}\frac{\lambda}{2}$$

$$= \cot^{-1}\frac{\lambda}{2} \text{ as } \tan^{-1}x + \cot^{-1}x = \pi/2 \forall x \in \mathbb{R}$$

$$S_n = \tan^{-1}\left(\frac{n+1}{2}\lambda\right) - \tan^{-1}\frac{\lambda}{2} \text{ and } S_\infty = \cot^{-1}\left(\frac{\lambda}{2}\right)$$

17. If the value of

$$\lim_{n \rightarrow \infty} \sum_{\lambda=2}^n \cos^{-1}\left[\frac{1 + \sqrt{(\lambda-1)(\lambda)(\lambda+1)(\lambda+2)}}{\lambda(\lambda+1)}\right] \text{ is equal}$$

to  $\frac{24\pi}{\mu}$ , then evaluate  $\mu$

**Solution:** The  $(\lambda - 1)$ th term of above series is

$$t_{\lambda-1} = \cos^{-1}\left[\frac{1 + \sqrt{(\lambda-1)\lambda(\lambda+1)(\lambda+2)}}{\lambda(\lambda+1)}\right]$$

$$\text{Let } \frac{1}{\lambda} = x; \frac{1}{\lambda+1} = y \Rightarrow x > y$$

$$\begin{aligned} \text{and } x > 0, y > 0 &\Rightarrow \sqrt{1-x^2} = \sqrt{1-1/\lambda^2} \\ &= \sqrt{\frac{\lambda^2-1}{\lambda^2}} = \frac{\sqrt{\lambda^2-1}}{\lambda} = \frac{\sqrt{(\lambda-1)(\lambda+1)}}{\lambda} \text{ and} \end{aligned}$$

$$\begin{aligned} \sqrt{1-y^2} &= \sqrt{1 - \frac{1}{(\lambda+1)^2}} = \sqrt{\frac{(\lambda+1)^2 - 1}{(\lambda+1)^2}} \\ &= \frac{\sqrt{\lambda^2 + 2\lambda}}{(\lambda+1)} = \frac{\sqrt{\lambda(\lambda+2)}}{(\lambda+1)} \end{aligned}$$

$$\therefore t_{\lambda-1} = \cos^{-1}\left[xy + \sqrt{1-x^2}\sqrt{1-y^2}\right]$$

$$= \cos^{-1}y - \cos^{-1}x = \cos^{-1}\frac{1}{\lambda+1} - \cos^{-1}\frac{1}{\lambda}$$

$$\left[\because \cos^{-1}x - \cos^{-1}y = \cos^{-1}(xy + \sqrt{1-x^2}\sqrt{1-y^2})\right]$$

for  $x \leq y$

$$\therefore t_{\lambda-1} = \cos^{-1}\frac{1}{(\lambda+1)} - \cos^{-1}\frac{1}{\lambda}$$

$$\Rightarrow \sum_{\lambda=2}^n t_{\lambda-1} = \cos^{-1}\frac{1}{(n+1)} - \cos^{-1}\frac{1}{2}$$

$$\therefore \lim_{n \rightarrow \infty} \sum_{\lambda=2}^n t_{\lambda-1} = \cos^{-1}\frac{1}{\infty} - \cos^{-1}\frac{1}{2} = \cos^{-1}0 - \cos^{-1}\frac{1}{2}$$

$$= \frac{\pi}{2} - \frac{\pi}{3} = \frac{\pi}{6} \text{ A.T.Q } \frac{\pi}{6} = \frac{24\pi}{\mu} \Rightarrow \mu = 144$$

18. Show that  $x = \operatorname{cosec}\left(\tan^{-1}\left(\cos\left(\cot^{-1}\left(\sec\left(\sin^{-1}a\right)\right)\right)\right)\right)$  and  $y = \sec\left(\cot^{-1}\left(\sin\left(\tan^{-1}\left(\operatorname{cosec}\left(\cos^{-1}a\right)\right)\right)\right)\right)$  are equal for  $a \in [0, 1]$

**Solution:**

$$\begin{aligned} x &= \operatorname{cosec}\left[\tan^{-1}\left(\cos\left(\cot^{-1}\left(\sec\left(\sec^{-1}\frac{1}{\sqrt{1-a^2}}\right)\right)\right)\right)\right] \\ &= \operatorname{cosec}\left[\tan^{-1}\left(\cos\left(\cot^{-1}\left(\frac{1}{\sqrt{1-a^2}}\right)\right)\right)\right] \\ &= \operatorname{cosec}\left[\tan^{-1}\left(\cos\left(\cos^{-1}\left(\frac{1}{\sqrt{2-a^2}}\right)\right)\right)\right] \\ &= \operatorname{cosec}\left[\tan^{-1}\left(\frac{1}{\sqrt{2-a^2}}\right)\right] \\ &= \operatorname{cosec}\left[\operatorname{cosec}^{-1}\left(\frac{\sqrt{3-a^2}}{1}\right)\right] = \sqrt{3-a^2} \dots (i) \end{aligned}$$

$$\begin{aligned} \text{Now } y &= \sec\left[\cot^{-1}\left(\sin\left(\tan^{-1}\left(\operatorname{cosec}\left(\cos^{-1}a\right)\right)\right)\right)\right] \\ &= \sec\cot^{-1}\left(\sin\left(\tan^{-1}\left(\operatorname{cosec}\left(\operatorname{cosec}^{-1}\frac{1}{\sqrt{1-a^2}}\right)\right)\right)\right) \\ &= \sec\left[\cot^{-1}\left(\sin\left(\tan^{-1}\frac{1}{\sqrt{1-a^2}}\right)\right)\right] \\ &= \sec\left[\cot^{-1}\left(\sin\left(\sin^{-1}\frac{1}{\sqrt{2-a^2}}\right)\right)\right] \\ &= \sec\left[\cot^{-1}\left(\frac{1}{\sqrt{2-a^2}}\right)\right] \\ &= \sec\left[\sec^{-1}\left(\sqrt{3-a^2}\right)\right] = \sqrt{3-a^2} \dots (ii) \end{aligned}$$

$\therefore$  From (i) and (ii) clearly  $x = y$

19. Find the range of the function  $f(x) = \sqrt{\sin^{-1}|\cos x| - \cos^{-1}|\sin x|}$  and hence solve the equations,  $\lambda = |\sin^{-1}|\cos x|| + |\cos^{-1}|\sin x||$ ; where  $\lambda \in \text{Range of } f(x)$

**Solution:**  $f(x) = \sqrt{\sin^{-1}|\cos x| - \cos^{-1}|\sin x|} \dots (i)$

$$\begin{aligned} f(\pi+x) &= \sqrt{\sin^{-1}|\cos(\pi+x)| - \cos^{-1}|\sin(\pi+x)|} \\ &= \sqrt{\sin^{-1}|\cos x| - \cos^{-1}|\sin x|} \end{aligned}$$

$$= \sqrt{\sin^{-1}|\cos x| - \cos^{-1}|\sin x|} = f(x).$$

$\Rightarrow f(x)$  is a periodic function with period  $\pi$ . Let us find the range of  $f(x)$  in period  $\left[\frac{-\pi}{2}, \frac{\pi}{2}\right]$ .

**Case (i)**  $x \in \left[\frac{-\pi}{2}, 0\right]$

$$\begin{aligned} &= \sin^{-1}|\sin\left(\frac{\pi}{2}+x\right)| = \sin^{-1}\left[\sin\left(\frac{\pi}{2}+x\right)\right] \\ &= \frac{\pi}{2}+x \text{ as } \frac{\pi}{2}+x \in \left[0, \frac{\pi}{2}\right] \end{aligned}$$

Also  $\cos^{-1}|\sin x|$

$$\begin{aligned} &= \cos^{-1}\left|\cos\left(\frac{\pi}{2}+x\right)\right| = \cos^{-1}\left[\cos\left(\frac{\pi}{2}+x\right)\right] \\ &= \frac{\pi}{2}+x, \text{ as } \frac{\pi}{2}+x \in \left[0, \frac{\pi}{2}\right] \end{aligned}$$

$$\therefore f(x) = \sqrt{\left(\frac{\pi}{2}+x\right) - \left(\frac{\pi}{2}+x\right)} = 0$$

**Case (ii)**  $x \in \left[\frac{\pi}{2}, \pi\right]$

$$\begin{aligned} \sin^{-1}|\cos x| &= \sin^{-1}(-\cos x) \\ &= \sin^{-1}\left[\sin\left(x-\frac{\pi}{2}\right)\right] = x-\frac{\pi}{2} \text{ as } x-\frac{\pi}{2} \in \left[0, \frac{\pi}{2}\right] \end{aligned}$$

and  $\cos^{-1}|\sin x| = \cos^{-1}(\sin x)$

$$\begin{aligned} &= \cos^{-1}\left(\cos\left(x-\frac{\pi}{2}\right)\right) \\ &= x-\frac{\pi}{2}, \text{ as } x-\frac{\pi}{2} \in \left[0, \frac{\pi}{2}\right] \end{aligned}$$

$$\therefore f(x) = \sqrt{\left(x-\frac{\pi}{2}\right) - \left(x-\frac{\pi}{2}\right)} = 0$$

$$\therefore \text{Range of } f(x) = \{0\} \Rightarrow \lambda = 0$$

$$\therefore f(x) = 0 \forall x \in \mathbb{R}$$

$$\therefore f(x) = |\sin^{-1}|\cos x|| + |\cos^{-1}|\sin x|| = \lambda;$$

$\lambda \in \text{Range of } f(x)$

$$\Rightarrow |\sin^{-1}|\cos x|| + |\cos^{-1}|\sin x|| = 0$$

$$\Rightarrow \sin^{-1}|\cos x| = 0; \cos^{-1}|\sin x| = 0 \text{ as } \sin^{-1}x, \cos^{-1}x \geq 0$$

$$\Rightarrow |\cos x| = 0; |\sin x| = 1 \Rightarrow \cos x = 0; \sin x = \pm 1$$

$$\Rightarrow x = (2n+1)\frac{\pi}{2}; n \in \mathbb{Z}$$

$$\therefore \text{Solution of given equation is } \left\{(2n+1)\frac{\pi}{2}; n \in \mathbb{Z}\right\}$$

20. Find the values of  $\sin^{-1}(\sin 7)$  and  $\sin^{-1}(\sin(-5))$ .

**Solution:** Let  $y = \sin^{-1}(\sin 7)$

$$\sin^{-1}(\sin 7) \neq 7 \text{ as } 7 \notin \left[-\frac{\pi}{2}, \frac{\pi}{2}\right]; \because 2\pi < 7 < \frac{5\pi}{2}$$

Graph of  $y = \sin^{-1}(\sin x)$  is as shown below:

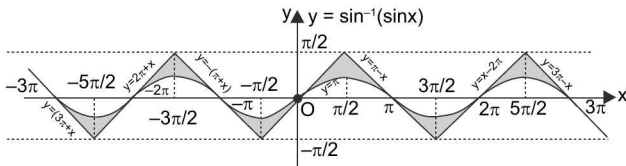

From the graph we can see that if  $2\pi \leq x \leq \frac{5\pi}{2}$  then  $y = x - 2\pi$

$$\Rightarrow y = \sin^{-1}(\sin 7) = 7 - 2\pi$$

Similarly, if we have to find  $\sin^{-1}(\sin(-5))$ , then

$$\because -2\pi < -5 < -\frac{3\pi}{2}$$

from the graph of  $\sin^{-1}(\sin x)$  we can see that  $\sin^{-1}(\sin(-5)) = 2\pi + (-5) = 2\pi - 5$

21. Find the value of  $\cos^{-1}\{\sin(-5)\}$ .

**Solution:** Let  $y = \cos^{-1}\{\sin(-5)\} = \cos^{-1}(-\sin 5)$

$$= \pi - \cos^{-1}(\sin 5) \quad (\because \cos^{-1}(-x) = \pi - \cos^{-1}x, |x| \leq 1)$$

$$= \pi - \cos^{-1}\left\{\cos\left(\frac{\pi}{2} - 5\right)\right\} \quad \dots(i)$$

Note that:  $-2\pi < \left(\frac{\pi}{2} - 5\right) < -\pi$

Graph of  $\cos^{-1}(\cos x)$  is as shown below:

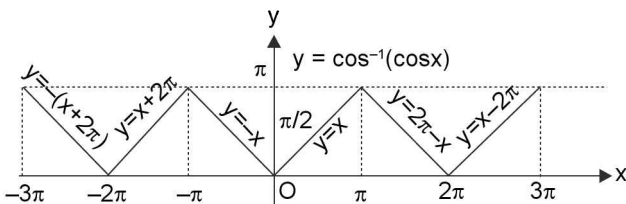

From the graph, we can see that if  $-2\pi \leq x \leq -\pi$  then  $\cos^{-1}(\cos x) = x + 2\pi$

$\therefore$  from the graph

$$\cos^{-1}\left\{\cos\left(\frac{\pi}{2} - 5\right)\right\} = \left(\frac{\pi}{2} - 5\right) + 2\pi = \left(\frac{5\pi}{2} - 5\right)$$

$\therefore$  from (i), we get

$$\therefore y = \pi - \left(\frac{5\pi}{2} - 5\right) \Rightarrow y = 5 - \frac{3\pi}{2}$$

22. Find the value of  $\tan\left(\frac{1}{2}\cos^{-1}\frac{\sqrt{5}}{3}\right)$ .

**Solution:** Let  $y = \tan\left(\frac{1}{2}\cos^{-1}\frac{\sqrt{5}}{3}\right)$  .....(i)

$$\text{Let } \cos^{-1}\frac{\sqrt{5}}{3} = \theta \Rightarrow \theta \in \left(0, \frac{\pi}{2}\right) \text{ and } \cos \theta = \frac{\sqrt{5}}{3}$$

$\therefore$  (i) becomes  $y = \tan\left(\frac{\theta}{2}\right)$  .....(ii)

$$\therefore \tan^2 \frac{\theta}{2} = \frac{1 - \cos \theta}{1 + \cos \theta} = \frac{1 - \frac{\sqrt{5}}{3}}{1 + \frac{\sqrt{5}}{3}} = \frac{3 - \sqrt{5}}{3 + \sqrt{5}} = \frac{(3 - \sqrt{5})^2}{4}$$

$$\tan \frac{\theta}{2} = \pm \left(\frac{3 - \sqrt{5}}{2}\right) \quad \dots\dots\dots(iii)$$

$$\frac{\theta}{2} \in \left(0, \frac{\pi}{4}\right) \Rightarrow \tan \frac{\theta}{2} > 0$$

$\therefore$  from (iii), we get  $y = \tan \frac{\theta}{2} = \left(\frac{3 - \sqrt{5}}{2}\right)$

23. Show that  $\sin^{-1}\frac{3}{5} + \sin^{-1}\frac{15}{17} = \pi - \sin^{-1}\frac{84}{85}$

**Solution:**  $\because \frac{3}{5} > 0, \frac{15}{17} > 0$  and

$$\left(\frac{3}{5}\right)^2 + \left(\frac{15}{17}\right)^2 = \frac{8226}{7225} > 1$$

$$\therefore \sin^{-1}\frac{3}{5} + \sin^{-1}\frac{15}{17} = \pi -$$

$$\sin^{-1}\left(\frac{3}{5}\sqrt{1 - \frac{225}{289}} + \frac{15}{17}\sqrt{1 - \frac{9}{25}}\right)$$

$$= \pi - \sin^{-1}\left(\frac{3}{5} \cdot \frac{8}{17} + \frac{15}{17} \cdot \frac{4}{5}\right) = \pi - \sin^{-1}\left(\frac{84}{85}\right)$$

24. Evaluate  $\cos^{-1}\frac{12}{13} + \sin^{-1}\frac{4}{5} - \tan^{-1}\frac{63}{16}$

**Solution:** Let  $z = \cos^{-1}\frac{12}{13} + \sin^{-1}\frac{4}{5} - \tan^{-1}\frac{63}{16}$

$$\sin^{-1}\frac{4}{5} = \frac{\pi}{2} - \cos^{-1}\frac{4}{5}$$

$$\therefore z = \cos^{-1}\frac{12}{13} + \left(\frac{\pi}{2} - \cos^{-1}\frac{4}{5}\right) - \tan^{-1}\frac{63}{16}$$

$$z = \frac{\pi}{2} - \left( \cos^{-1} \frac{4}{5} - \cos^{-1} \frac{12}{13} \right) - \tan^{-1} \frac{63}{16} \quad \dots(i)$$

$$\therefore \frac{4}{5} > 0, \frac{12}{13} > 0 \text{ and } \frac{4}{5} < \frac{12}{13}$$

$$\therefore \cos^{-1} \frac{4}{5} - \cos^{-1} \frac{12}{13} =$$

$$\cos^{-1} \left[ \frac{4}{5} \times \frac{12}{13} + \sqrt{1 - \frac{16}{25}} \sqrt{1 - \frac{144}{169}} \right] = \cos^{-1} \left( \frac{63}{65} \right)$$

\(\therefore\) Equation (i) can be written as

$$z = \frac{\pi}{2} - \cos^{-1} \left( \frac{63}{65} \right) - \tan^{-1} \left( \frac{63}{16} \right)$$

$$z = \sin^{-1} \left( \frac{63}{65} \right) - \tan^{-1} \left( \frac{63}{16} \right) \quad \dots(ii)$$

$$\therefore \sin^{-1} \left( \frac{63}{65} \right) = \tan^{-1} \left( \frac{63}{16} \right)$$

\(\therefore\) From equation (ii), we get

$$\therefore z = \tan^{-1} \left( \frac{63}{16} \right) - \tan^{-1} \left( \frac{63}{16} \right) \Rightarrow z = 0$$

25. Evaluate  $\tan^{-1} 9 + \tan^{-1} \frac{5}{4}$

**Solution:** \(\because\)  $9 > 0, \frac{5}{4} > 0$  and  $\left( 9 \times \frac{5}{4} \right) > 1$

$$\begin{aligned} \therefore \tan^{-1} 9 + \tan^{-1} \frac{5}{4} &= \pi + \tan^{-1} \left( \frac{9 + \frac{5}{4}}{1 - 9 \cdot \frac{5}{4}} \right) \\ &= \pi + \tan^{-1} (-1) = \pi - \frac{\pi}{4} = \frac{3\pi}{4} \end{aligned}$$

26. Let  $\alpha = \sin^{-1} \left( \frac{36}{85} \right), \beta = \cos^{-1} \left( \frac{4}{5} \right)$  and

$$\gamma = \tan^{-1} \left( \frac{8}{15} \right), \text{ find } (\alpha + \beta + \gamma) \text{ and}$$

hence prove that

(i)  $\sum \cot \alpha = \prod \cot \alpha,$

(ii)  $\sum \tan \alpha \cdot \tan \beta = 1$

**Solution:**  $\sin \frac{36}{85}$

$$\Rightarrow \sin \alpha = \frac{36}{85} \Rightarrow \tan \alpha = \frac{36}{77}$$

$$\beta = \cos^{-1} \left( \frac{4}{5} \right)$$

$$\cos \beta = \frac{4}{5} \Rightarrow \tan \beta = \frac{3}{4} \text{ and } \tan \gamma = \frac{8}{15}$$

$$\tan (\alpha + \beta + \gamma) =$$

$$\begin{aligned} & \frac{\tan \alpha + \tan \beta + \tan \gamma - \tan \alpha \tan \beta \tan \gamma}{1 - \tan \alpha \tan \beta - \tan \beta \tan \gamma - \tan \gamma \tan \alpha} \\ &= \frac{\frac{36}{77} + \frac{3}{4} + \frac{8}{15} - \frac{36}{77} \cdot \frac{3}{4} \cdot \frac{8}{15}}{1 - \left( \frac{36}{77} \times \frac{3}{4} + \frac{8}{15} \times \frac{3}{4} + \frac{8}{15} \times \frac{36}{77} \right)} \end{aligned}$$

$$\tan (\alpha + \beta + \gamma) = \infty$$

$$\alpha + \beta + \gamma = \frac{\pi}{2}$$

(i)  $\cot \alpha + \cot \beta + \cot \gamma$

$$= \frac{1}{\tan \alpha} + \frac{1}{\tan \beta} + \frac{1}{\tan \gamma} = \frac{77}{36} + \frac{4}{3} + \frac{15}{8} = \frac{385}{72}$$

$$\Pi \cot \alpha = \frac{1}{\tan \alpha \tan \beta \tan \gamma} = \frac{77}{36} \times \frac{4}{3} \times \frac{15}{8} = \frac{385}{72}$$

$$\therefore \cot \alpha \cot \beta \cot \gamma = \Pi \cot \alpha = \sum \cot \alpha$$

(ii)  $\sum \tan \alpha \tan \beta$

$$\tan \alpha \tan \beta + \tan \beta \tan \gamma + \tan \gamma \tan \alpha$$

$$= \frac{36}{77} \times \frac{3}{4} + \frac{3}{4} \times \frac{8}{15} + \frac{8}{15} \times \frac{36}{77} = 1$$

27. Prove that:

$$\tan^{-1} \left( \frac{3 \sin 2\alpha}{5 + 3 \cos 2\alpha} \right) + \tan^{-1} \left( \frac{\tan \alpha}{4} \right) = \alpha$$

$$\left( \text{where } -\frac{\pi}{2} < \alpha < \frac{\pi}{2} \right)$$

**Solution:** L.H.S.  $\tan^{-1} \left[ \frac{3 \sin 2\alpha}{5 + 3 \cos 2\alpha} \right] + \tan^{-1} \left( \frac{\tan \alpha}{4} \right);$

where  $-\frac{\pi}{2} < \alpha < \frac{\pi}{2}$

Let  $\tan \alpha = t$

$$\text{L.H.S.} = \tan^{-1} \left( \frac{3 \left( \frac{2 \tan \alpha}{1 + \tan^2 \alpha} \right)}{5 + 3 \left( \frac{1 - \tan^2 \alpha}{1 + \tan^2 \alpha} \right)} \right) + \tan^{-1} \left( \frac{\tan \alpha}{4} \right)$$

$$= \tan^{-1} \left( \frac{6t}{8 + 2t^2} \right) + \tan^{-1} \left( \frac{t}{4} \right)$$

$$= \tan^{-1}(t) = \tan^{-1}(\tan \alpha) = \alpha = \text{R.H.S.}$$

28. Prove the identities.

$$(a) \sin^{-1} \cos(\sin^{-1} x) + \cos^{-1} \sin(\cos^{-1} x) = \frac{\pi}{2}, |x| \leq 1$$

$$(b) 2 \tan^{-1} (\operatorname{cosec} \tan^{-1} x - \tan \cot^{-1} x) = \tan^{-1} x \quad (x \neq 0)$$

$$(c) \tan^{-1} \left( \frac{2mn}{m^2 - n^2} \right) + \tan^{-1} \left( \frac{2pq}{p^2 - q^2} \right) = \tan^{-1} \left( \frac{2MN}{M^2 - N^2} \right)$$

where  $M = mp - nq$ ,  $N = np + mq$ ,

$$\left| \frac{n}{m} \right| < 1; \left| \frac{q}{p} \right| < 1 \text{ and } \left| \frac{N}{M} \right| < 1$$

$$(d) \tan(\tan^{-1} x + \tan^{-1} y + \tan^{-1} z) = \cot(\cot^{-1} x + \cot^{-1} y + \cot^{-1} z); \text{ where } x, y, z > 0$$

**Solution:** (a)

$$\text{LHS} = \sin^{-1} (\cos(\sin^{-1} x)) + \cos^{-1} (\sin(\cos^{-1} x))$$

$$(i) -1 \leq x \leq 0, \text{ put } x = -|x|$$

$$\text{LHS} = \sin^{-1} (\cos(\sin^{-1}(-|x|))) + \cos^{-1} (\sin(\cos^{-1}(-|x|)))$$

$$= \sin^{-1} (\cos(-\sin^{-1}(|x|))) + \cos^{-1} (\sin(\pi - \cos^{-1}(|x|)))$$

$$= \sin^{-1} (\cos(\sin^{-1}(|x|))) + \cos^{-1} (\sin(\cos^{-1}(|x|)))$$

$$= \sin^{-1} \left( \cos \left( \cos^{-1} \left( \frac{\sqrt{1-x^2}}{1} \right) \right) \right) +$$

$$\cos^{-1} \left( \sin \left( \sin^{-1} \sqrt{1-x^2} \right) \right)$$

$$= \sin^{-1} (\sqrt{1-x^2}) + \cos^{-1} (\sqrt{1-x^2})$$

$$= \pi/2 = \text{R.H.S.}$$

$$(ii) 0 < x \leq 1$$

$$\text{LHS} = \sin^{-1} (\cos(\sin^{-1} x)) + \cos^{-1} (\sin(\cos^{-1} x))$$

$$= \sin^{-1} (\cos(\cos^{-1}(\sqrt{1-x^2}))) + \cos^{-1} (\sin(\sin^{-1}(\sqrt{1-x^2})))$$

$$= \sin^{-1} (\sqrt{1-x^2}) + \cos^{-1} (\sqrt{1-x^2})$$

$$= \pi/2 = \text{RHS proved.}$$

$$(b) 2 \tan^{-1} (\operatorname{cosec} \tan^{-1} x - \tan \cot^{-1} x) = \tan^{-1} x$$

**case (i):**  $x < 0$ , put  $x = -|x|$

$$\text{L.H.S.} = 2 \tan^{-1} (\operatorname{cosec}(\tan^{-1}(-|x|)) - \tan(\cot^{-1}(-|x|)))$$

$$= 2 \tan^{-1} (\operatorname{cosec}(-\tan^{-1}|x|) - \tan(\pi - \cot^{-1}|x|))$$

$$= 2 \tan^{-1} (-\operatorname{cosec}(\tan^{-1}|x|) + \tan(\cot^{-1}|x|))$$

$$\begin{aligned} &= 2 \tan^{-1} \left( -\operatorname{cosec} \left( \operatorname{cosec}^{-1} \frac{\sqrt{1+x^2}}{|x|} \right) + \tan \left( \tan^{-1} \frac{1}{|x|} \right) \right) \\ &= 2 \tan^{-1} \left( -\frac{\sqrt{1+x^2}}{|x|} + \frac{1}{|x|} \right) \\ &= 2 \tan^{-1} \left( \frac{1-\sqrt{1+x^2}}{|x|} \right); \text{ (put } |x| = \tan \theta) \\ &= 2 \tan^{-1} \left( \frac{1-\sqrt{1+\tan^2 \theta}}{\tan \theta} \right) = 2 \tan^{-1} \left( \frac{1-\cos \theta}{\tan \theta \cdot \cos \theta} \right) \\ &= 2 \tan^{-1} \left( \frac{2 \sin^2 \theta/2}{2 \sin \theta/2 \cos \theta/2} \right) = 2 \tan^{-1} (\tan \theta/2) \\ &= 2 \tan^{-1} \left( \tan \frac{\theta}{2} \right) = 2 \cdot \frac{\theta}{2} = \theta = \tan^{-1}|x| \end{aligned}$$

$$(ii) x > 0$$

$$\text{LHS} = 2 \tan^{-1} (\operatorname{cosec}(\tan^{-1} x)) - \tan(\cot^{-1} x)$$

$$= 2 \tan^{-1} \left( \operatorname{cosec} \left( \operatorname{cosec}^{-1} \left( \frac{\sqrt{1+x^2}}{x} \right) \right) - \tan \left( \tan^{-1} \frac{1}{x} \right) \right)$$

$$= 2 \tan^{-1} \left( \frac{\sqrt{1+x^2}}{x} - \frac{1}{x} \right)$$

$$= 2 \tan^{-1} \left( \frac{\sqrt{1+x^2}-1}{x} \right) = 2 \tan^{-1} \left( \frac{\sec \theta - 1}{\tan \theta} \right)$$

$$= 2 \tan^{-1} \left( \frac{-\cos \theta + 1}{\sin \theta} \right) \quad (\tan \theta = x)$$

$$= 2 \tan^{-1} \left( \frac{2 \sin^2 \theta/2}{2 \sin \theta/2 \cos \theta/2} \right) = 2 \tan^{-1} \left( \tan \frac{\theta}{2} \right) = \theta$$

$$= \tan^{-1} x$$

$$(c) \left| \frac{n}{m} \right| < 1; \left| \frac{q}{p} \right| < 1$$

$$\text{Now } \tan^{-1} \left( \frac{2mn}{m^2 - n^2} \right) + \tan^{-1} \left( \frac{2pq}{p^2 - q^2} \right)$$

$$= \tan^{-1} \left[ \frac{2 \left( \frac{n}{m} \right)}{1 - \left( \frac{n}{m} \right)^2} \right] + \tan^{-1} \left[ \frac{2 \left( \frac{q}{p} \right)}{1 - \left( \frac{q}{p} \right)^2} \right]$$



4.82 > Trigonometry

$$= 2 \tan^{-1} \left( \frac{n}{m} \right) + 2 \tan^{-1} \left( \frac{q}{p} \right)$$

$$\left( \text{as } 2 \tan^{-1} x = \tan^{-1} \left( \frac{2x}{1-x^2} \right) \text{ for } |x| < 1 \right)$$

$$= 2 \left[ \tan^{-1} \frac{n}{m} + \tan^{-1} \frac{q}{p} \right] \quad \dots(i)$$

$$\text{Now } \left| \frac{N}{M} \right| < 1 \Rightarrow \left| \frac{np+mq}{mp-nq} \right| < 1 \quad \dots(ii)$$

$$\text{Also } \left| \frac{n}{m} \cdot \frac{q}{p} \right| = \left| \frac{n}{m} \right| \left| \frac{q}{p} \right| < 1$$

\(\therefore\) from (i)

$$= 2 \left[ \tan^{-1} \left( \frac{\frac{n}{m} \cdot \frac{q}{p}}{1 - \frac{n}{m} \cdot \frac{q}{p}} \right) \right] = 2 \tan^{-1} \left[ \frac{np}{mp} \cdot \frac{mq}{nq} \right]$$

$$= \tan^{-1} \left[ \frac{2 \left( \frac{np+mq}{mp-nq} \right)}{1 - \left( \frac{np+mq}{mp-nq} \right)^2} \right] \quad (\because \text{ of (ii)})$$

$$= \tan^{-1} \left[ \frac{2(np+mq)(mp-nq)}{(mp-nq)^2 - (np+mq)^2} \right] = \tan^{-1} \left[ \frac{2MN}{M^2 - N^2} \right]$$

where  $M = mp - nq$  and  $N = np + mq$ .

Hence proved

$$(d) \text{ LHS} = \tan (\tan^{-1}x + \tan^{-1}y + \tan^{-1}z)$$

$$= \tan \left( \tan^{-1} \left( \frac{x+y+z-xyz}{1-xy-yz-zx} \right) \right)$$

$$= \frac{x+y+z-xyz}{1-xy-yz-zx} \quad \dots(i)$$

$$\text{RHS} = \cot (\cot^{-1}x + \cot^{-1}y + \cot^{-1}z)$$

$$= \cot \left( \tan^{-1} \frac{1}{x} + \tan^{-1} \frac{1}{y} + \tan^{-1} \frac{1}{z} \right)$$

$$= \cot \left( \tan^{-1} \left( \frac{\frac{1}{x} + \frac{1}{y} + \frac{1}{z} - \frac{1}{xyz}}{1 - \frac{1}{xy} - \frac{1}{yz} - \frac{1}{zx}} \right) \right)$$

$$= \cot \left( \tan^{-1} \left( \frac{xy+yz+zx-1}{xyz-x-y-z} \right) \right)$$

$$= \cot \left( \tan^{-1} \left( \frac{1-xy-yz-zx}{x+y+z-xyz} \right) \right)$$

$$= \cot \left( \cot^{-1} \left( \frac{x+y+z-xyz}{1-xy-yz-zx} \right) \right)$$

$$= \frac{x+y+z-xyz}{1-xy-yz-zx} \quad \dots(ii)$$

from equation (i) and (ii) LHS = RHS

29. In a  $\Delta ABC$ , if  $\angle A = \angle B =$

$$\frac{1}{2} \left( \sin^{-1} \left( \frac{\sqrt{6}+1}{2\sqrt{3}} \right) + \sin^{-1} \left( \frac{1}{\sqrt{3}} \right) \right) \text{ and } c = 6.3^{\frac{1}{4}},$$

then find the area of  $\Delta ABC$ .

$$\text{Solution: } \sin^{-1} \left( \frac{\sqrt{6}+1}{2\sqrt{3}} \right) + \sin^{-1} \left( \frac{1}{\sqrt{3}} \right)$$

$$= \tan^{-1} \left( \frac{\sqrt{6}+1}{\sqrt{3}-\sqrt{2}} \right) + \tan^{-1} \left( \frac{1}{\sqrt{2}} \right)$$

$$= \pi + \tan^{-1} \left( \frac{\frac{\sqrt{6}+1}{\sqrt{3}-\sqrt{2}} + \frac{1}{\sqrt{2}}}{1 - \frac{\sqrt{6}+1}{\sqrt{3}-\sqrt{2}} \cdot \frac{1}{\sqrt{2}}} \right) \left[ \because \frac{\sqrt{6}+1}{\sqrt{3}-\sqrt{2}} \cdot \frac{1}{\sqrt{2}} > 1 \right]$$

$$= \pi + \tan^{-1} \left( \frac{(\sqrt{6}+1)\sqrt{2} + (\sqrt{3}-\sqrt{2})}{\sqrt{2}(\sqrt{3}-\sqrt{2}) - (\sqrt{6}+1)} \right)$$

$$= \pi + \tan^{-1} \left( \frac{\sqrt{12} + \sqrt{2} + \sqrt{3} - \sqrt{2}}{\sqrt{6} - 2 - \sqrt{6} - 1} \right) = \tan^{-1} \left( \frac{2\sqrt{3} + \sqrt{3}}{-3} \right)$$

$$= \pi + \tan^{-1} \left( \frac{3\sqrt{3}}{-3} \right) = \pi + \tan^{-1} (-\sqrt{3}) = \pi - \frac{\pi}{3} = \frac{2\pi}{3}$$

According to the question

$$\angle A = \angle B = \frac{1}{2} \left( \sin^{-1} \left( \frac{\sqrt{6}+1}{2\sqrt{2}} \right) + \sin^{-1} \left( \frac{1}{\sqrt{3}} \right) \right)$$

$$\Rightarrow \angle A = \angle B = \frac{1}{2} \left( \frac{2\pi}{3} \right)$$

$$\Rightarrow \angle A = \angle B = \frac{\pi}{3}$$

$$\Rightarrow \angle C = \pi - \frac{2\pi}{3} = \pi - \frac{2\pi}{3}$$

\(\Rightarrow\)  $\Delta ABC$  is an equilateral  $\Delta$

$$\therefore \text{ar}(\Delta ABC) = \frac{\sqrt{3}}{4} a^2 = \frac{\sqrt{3}}{4} c^2$$

$$= \frac{\sqrt{3}}{4} \cdot (6.3^{1/4})^2 = \frac{\sqrt{3}}{4} \sqrt{3} (6 \times 6)$$

$$= 3 \times 3 \times 3 = 27 \text{ square units}$$

30. Find the integral values of  $k$  for which the system of equations:

$$\begin{cases} (\text{arc cos } x) + (\text{arc sin } y)^2 = \frac{k\pi^2}{4} \\ (\text{arc sin } y)^2 \cdot (\text{arc cos } x) = \frac{\pi^4}{16} \end{cases} \text{ possesses solutions}$$

and find those solutions.

**Solution:**  $\cos^{-1}x + (\sin^{-1}y)^2 = \frac{k\pi^2}{4}$  ... (i)

$(\cos^{-1}x)(\sin^{-1}y)^2 = \frac{\pi^4}{16}$  ... (ii)

Let  $\cos^{-1}x = a \Rightarrow a \in [0, \pi]$

$\sin^{-1}y = b \in \left[-\frac{\pi}{2}, \frac{\pi}{2}\right]$

Then equation (i) and (ii) become

$a + b^2 = \frac{k\pi^2}{4}$  ... (iii)

$ab^2 = \frac{\pi^4}{16}$  ... (iv)

$\therefore -\frac{\pi}{2} \leq b \leq \frac{\pi}{2}$

$0 \leq b^2 \leq \frac{\pi^2}{4}; 0 \leq a + b^2 \leq \pi + \frac{\pi^2}{4}$

$0 \leq k \frac{\pi^2}{4} \leq \pi + \frac{\pi^2}{4}; 0 \leq k \leq \frac{4}{\pi} + 1$

$\therefore k$  is integers so  $k = 0, 1, 2$

if  $k = 0$  from equation (ii); we get  $a = b = 0$

from (iii)  $b^2 = \frac{k\pi^2}{4} - a$  put in (iv)

$a \left( \frac{k\pi^2}{4} - a \right) = \frac{\pi^4}{16}$

$16a^2 - 4k\pi^2a + \pi^4 = 0$  ... (v)

$\therefore a \in \mathbb{R}$

$D \geq 0$

$k^2 \geq 4; k \geq 2$

so  $k = 2$

put  $k = 2$  in (v)

$16a^2 - 8\pi^2a + \pi^4 = 0; (4a - \pi^2)^2 = 0$

$a = \frac{\pi^2}{4} = \cos^{-1}x; x = \cos \frac{\pi^2}{4}$

from (iv); we get  $\frac{\pi^2}{4}b^2 = \frac{\pi^4}{16}; b = \pm \frac{\pi}{2} = \sin^{-1}y$

$\Rightarrow y = \pm 1$

so  $k = 2$

$x = \cos^{-1} \frac{\pi^2}{4} y = \pm 1$

31. Prove that the equation,  $(\sin^{-1}x)^3 + (\cos^{-1}x)^3 = \alpha\pi^3$  has no roots for  $\alpha < \frac{1}{32}$  and  $\alpha > \frac{7}{8}$ .

**Solution:**  $(\sin^{-1}x)^3 + (\cos^{-1}x)^3 = \alpha\pi^3$

$\Rightarrow (\sin^{-1}x + \cos^{-1}x) \cdot [(\sin^{-1}x + \cos^{-1}x)^2 - 3\sin^{-1}x\cos^{-1}x] = \alpha\pi^3$

$= \frac{\pi}{2} \left[ \frac{\pi^2}{4} - 3\sin^{-1}x\cos^{-1}x \right] = \alpha\pi^3$

$\Rightarrow \sin^{-1}x \left( \frac{\pi}{2} - \sin^{-1}x \right) = \frac{\pi^2}{12}(1 - 8\alpha)$

$\Rightarrow (\sin^{-1}x)^2 - \frac{\pi}{2}\sin^{-1}x = -\frac{\pi^2}{12}(1 - 8\alpha)$

$\left( \sin^{-1}x - \frac{\pi}{4} \right)^2 = \frac{\pi^2}{48}(32\alpha - 1)$  ... (1)

$\therefore -\frac{\pi}{2} \leq \sin^{-1}x \leq \frac{\pi}{2}$

$\Rightarrow -\frac{3\pi}{4} \leq \sin^{-1}x - \frac{\pi}{4} \leq \frac{\pi}{4}$

$\Rightarrow 0 \leq \left( \sin^{-1}x - \frac{\pi}{4} \right)^2 \leq \frac{9\pi^2}{16}$

from (1);  $0 \leq \frac{\pi^2}{48}(32\alpha - 1) \leq \frac{9\pi^2}{16}; \frac{1}{32} \leq \alpha \leq \frac{7}{8}$

so given equation has no roots

for  $\alpha < \frac{1}{32}$  and  $\alpha > \frac{7}{8}$

32. Show that the roots  $r, s,$  and  $t$  of the cubic  $x(x-2)(3x-7) = 2$ , are real and positive. Also compute the value of  $\tan^{-1}(r) + \tan^{-1}(s) + \tan^{-1}(t)$ .

**Solution:**  $x(x-2)(3x-7) = 2$

$\Rightarrow 3x^3 - 13x^2 + 14x - 2 = 0$

Now,  $r, s, t$  are roots of equation,

$\Rightarrow r + s + t = \frac{13}{3}$

and  $rs + st + ts = \frac{14}{3}, rst = \frac{2}{3}$

Now,  $\tan^{-1}r + \tan^{-1}s + \tan^{-1}t = \tan^{-1} \left[ \frac{r+s+t-rst}{1-(rs+st+tr)} \right]$

$= \pi + \tan^{-1} \left[ \frac{r+s+t-rst}{1-(rs+st+tr)} \right] (\because rs+st+tr > 1)$

$= \pi + \tan^{-1} \left[ \frac{\frac{13}{3} - \frac{2}{3}}{1 - \frac{14}{3}} \right]$

$\pi + \tan^{-1}(-1) = \pi - \frac{\pi}{4} = \frac{3\pi}{4}$

**Comprehension Passage Type**

**A:** Consider the summation  $\sum_{\mu=1}^{2k} \sum_{\lambda=1}^{2k} \cot^{-1} \left( \frac{\lambda}{\mu} \right) = f(k)\pi$ ,

then answer the following questions

- 33.** Which of the following is true?  
 (a)  $f(k)$  = sum of first  $k^2$  natural numbers  
 (b)  $f(k)$  = sum of first  $k$  odd natural nos.  
 (c)  $f(k) = k^2 - 2k + 5$   
 (d) None of these
- 34.** The range of function  $f(k)$  is  
 (a)  $(-\infty, \infty)$  (b)  $[0, \infty)$   
 (c)  $(-\infty, -2] \cup [2, \infty)$  (d)  $\{n^2; n \in \mathbb{N}\}$
- 35.** The roots of equation  $f(k) + \frac{1}{k}f(k) - 20 = 0$  are  
 (a) 4 (b) -5,4  
 (c) 3,4 (d) None of these
- 36.** The solution of inequality  $f(k) - 100 < 0$  is  
 (a)  $[-10, 10]$  (b)  $[0, 10]$   
 (c)  $[1, 10]$  (d)  $\{1, 2, 3, 4, \dots, 9\}$
- 37.** The value of  $\tan^{-1}(\sqrt{f(2)-1}) + \sin^{-1}\left(\frac{\sqrt{f(2)-1}}{\sqrt{f(2)}}\right)$  is

- (a)  $\frac{\pi}{4}$  (b)  $\frac{\pi}{3}$   
 (c)  $\frac{2\pi}{3}$  (d)  $\frac{5\pi}{6}$

**Solution:** Given  $\sum_{\mu=1}^{2k} \sum_{\lambda=1}^{2k} \cot^{-1} \left( \frac{\lambda}{\mu} \right) = f(k)\pi$

Given summation

$$\begin{aligned} &= \sum_{\mu=1}^{2k} \cot^{-1} \left( \frac{1}{\mu} \right) + \cot^{-1} \left( \frac{2}{\mu} \right) + \cot^{-1} \left( \frac{3}{\mu} \right) + \dots + \cot^{-1} \left( \frac{2k}{\mu} \right) \\ &= \cot^{-1} \left( \frac{1}{1} \right) + \cot^{-1} \left( \frac{1}{2} \right) + \cot^{-1} \left( \frac{1}{3} \right) + \dots + \cot^{-1} \left( \frac{1}{2k} \right) \\ &+ \cot^{-1} \left( \frac{2}{1} \right) + \cot^{-1} \left( \frac{2}{2} \right) + \cot^{-1} \left( \frac{2}{3} \right) + \dots + \cot^{-1} \left( \frac{2}{2k} \right) \\ &+ \cot^{-1} \left( \frac{3}{1} \right) + \cot^{-1} \left( \frac{3}{2} \right) + \cot^{-1} \left( \frac{3}{3} \right) + \dots + \cot^{-1} \left( \frac{3}{2k} \right) \\ &+ \cot^{-1} \left( \frac{2k}{1} \right) + \cot^{-1} \left( \frac{2k}{2} \right) + \cot^{-1} \left( \frac{2k}{3} \right) + \dots + \cot^{-1} \left( \frac{2k}{2k} \right) \\ &= 2k \left( \cot^{-1}(1) \right) + \left[ \cot^{-1} \frac{1}{2} + \cot^{-1} \left( \frac{2}{1} \right) \right] \end{aligned}$$

$$\begin{aligned} &+ \left[ \cot^{-1} \left( \frac{1}{3} \right) + \cot^{-1} \left( \frac{3}{1} \right) \right] + \left[ \cot^{-1} \left( \frac{1}{4} \right) + \cot^{-1} \left( \frac{4}{1} \right) \right] + \dots \\ &+ \left[ \cot^{-1} \left( \frac{2k}{3} \right) + \cot^{-1} \left( \frac{3}{2k} \right) \right] + \dots \end{aligned}$$

$\left\{ \begin{array}{l} \therefore \text{Diagonal elements are each equal to } \cot^{-1}(1) \\ \text{which are } 2k \text{ in counting and the elements above} \\ \text{and below diagonal forms pairs of the form} \\ \cot^{-1} \left( \frac{m}{n} \right) + \cot^{-1} \left( \frac{n}{m} \right) \text{ and they are } \left( \frac{(2k)^2 - 2k}{2} \right) \\ \text{in counting} \end{array} \right\}$

$$\begin{aligned} &= 2k \left( \frac{\pi}{4} \right) + \frac{(2k)^2 - 2k}{2} \cdot \frac{\pi}{2} \\ &= \frac{k\pi}{2} + \frac{[2k^2 - k]\pi}{2} = (k + 2k^2 - k) \frac{\pi}{2} = k^2\pi = f(k)\pi \end{aligned}$$

given

$$\therefore f(k) = k^2$$

- 33.**  $f(k) = k^2 = 1 + 3 + 5 + \dots + (2k-1)$   
 = sum of first  $k$  odd natural nos.  
 $\Rightarrow$  Option (b) is correct
- 34.**  $f(k) = k^2$   
 $\Rightarrow$  range of  $f(k) = [0, \infty)$   
 But  $k \in \mathbb{N}$   
 $\Rightarrow$  Range of  $f(k) = \{1, 4, 9, 16, \dots\}$  **Ans (d)**

**35.**  $f(k) + \frac{f(k)}{k} - 20 = 0$   
 $\Rightarrow k^2 + \frac{1}{k}(k^2) - 20 = 0$   
 $\Rightarrow k^2 + k - 20 = 0 \Rightarrow (k+5)(k-4) = 0$   
 $\Rightarrow k = -5$  or  $k = 4$  But  $k \in \mathbb{N}$   
 $\Rightarrow k = 4$  is the only root of given equation

**36.**  $f(k) - 100 < 0$   
 $\Rightarrow k^2 - 100 < 0$   
 $\Rightarrow k \in (-10, 10)$  But  $k \in \mathbb{N}$   
 Solution set of given inequality will be  $\{1, 2, 3, 4, 5, \dots, 9\}$

**37.**  $\tan^{-1}(\sqrt{f(2)-1}) + \sin^{-1}\left(\frac{\sqrt{f(2)-1}}{\sqrt{f(2)}}\right) =$   
 $\tan^{-1}(\sqrt{3}) + \sin^{-1}\left(\frac{\sqrt{3}}{2}\right) = \frac{\pi}{3} + \frac{\pi}{3} = \frac{2\pi}{3} \Rightarrow (c)$

B: If it is given that  $\sin(\cos^{-1}x) = \sqrt{1-x^2}$  for all  $x$ ,  
 $\cos(\sin^{-1}x) = \sqrt{1-x^2}$  for all  $x$  and  $\tan(\cot^{-1}x) = \frac{1}{x}$   
 for all  $x \neq 0$ , then

38.  $\sin(\cos^{-1}x + \sin^{-1}(x-2)) =$   
 (a)  $-1$   
 (b)  $1$   
 (c)  $\sqrt{1-x^2}\sqrt{-x^2+4x-3} + x(x-2)$   
 (d)  $\sqrt{1-x^2}\sqrt{x^2-4x+3} + x(x-2)$

**Solution:** (a)  $\cos^{-1}x \Rightarrow -1 \leq x \leq 1$   
 $\sin^{-1}(x-2) \Rightarrow -1 \leq x-2 \leq 1 \Rightarrow 1 \leq x \leq 3$   
 $\therefore x = 1$   
 $\therefore \sin(\cos^{-1}x + \sin^{-1}(x-2)) = \sin(\cos^{-1}1 + \sin^{-1}(-1))$   
 $= \sin\left(-\frac{\pi}{2}\right) = -1$

39.  $\cos\left(\sin^{-1}\frac{1}{x+1} + \cos^{-1}\frac{1}{x+2}\right) =$   
 (a)  $\frac{\sqrt{3} + \sqrt{8}}{6}$  (b)  $\frac{-\sqrt{3} + \sqrt{8}}{6}$   
 (c)  $\frac{\sqrt{3} - \sqrt{8}}{6}$  (d)  $0$

**Solution:** (c)  
 $\cos\left(\sin^{-1}\frac{1}{2} + \cos^{-1}\frac{1}{3}\right) = \cos\left(\sin^{-1}\frac{1}{2}\right)$   
 $\cos\left(\cos^{-1}\frac{1}{3}\right) - \sin\left(\sin^{-1}\frac{1}{2}\right)\sin\left(\cos^{-1}\frac{1}{3}\right)$   
 $= \sqrt{1-\frac{1}{4}} \cdot \frac{1}{3} - \frac{1}{2} \sqrt{1-\frac{1}{9}} = \frac{\sqrt{3}-\sqrt{8}}{6}$

40.  $\tan\left(\tan^{-1}\{(x+1)^2+1\} + \cot^{-1}\frac{1}{x+2}\right) =$   
 (a)  $\frac{4}{7}$  (b)  $-\frac{4}{7}$   
 (c)  $\frac{3}{7}$  (d) Not defined

**Solution:** (b)  $\tan\left(\tan^{-1}5 + \cot^{-1}\frac{1}{3}\right) =$   
 $\frac{\tan(\tan^{-1}5) + \tan\left(\cot^{-1}\frac{1}{3}\right)}{1 - \tan(\tan^{-1}5)\tan\left(\cot^{-1}\frac{1}{3}\right)} = \frac{5+3}{1-15} = -\frac{4}{7}$

C: It is given that  $A = (\tan^{-1}x)^3 + (\cot^{-1}x)^3$ , where  
 $x > 0$  and  $B = (\cos^{-1}t)^2 + (\sin^{-1}t)^2$ , where  $t \in \left[0, \frac{1}{\sqrt{2}}\right]$ ,

and  $\sin^{-1}x + \cos^{-1}x = \frac{\pi}{2}$  for  $-1 \leq x \leq 1$  and  
 $\tan^{-1}x + \cot^{-1}x = \frac{\pi}{2}$  for all  $x \in \mathbb{R}$

41. The interval in which  $A$  lies is  
 (a)  $\left[\frac{\pi^3}{7}, \frac{\pi^3}{2}\right]$  (b)  $\left[\frac{\pi^3}{32}, \frac{\pi^3}{8}\right]$   
 (c)  $\left[\frac{\pi^3}{40}, \frac{\pi^3}{10}\right]$  (d) None of these

**Solution:** (b)  $A = (\tan^{-1}x)^3 + (\cot^{-1}x)^3$   
 $\Rightarrow A = (\tan^{-1}x + \cot^{-1}x)^3 - 3\tan^{-1}x \cot^{-1}x(\tan^{-1}x + \cot^{-1}x)$   
 $\Rightarrow A = \left(\frac{\pi}{2}\right)^3 - 3\tan^{-1}x \cot^{-1}x \frac{\pi}{2}$   
 $\Rightarrow \frac{\pi^3}{8} - \frac{3\pi}{2} \tan^{-1}x \left(\frac{\pi}{2} - \tan^{-1}x\right)$   
 $= \frac{\pi^3}{32} + \frac{3\pi}{2} \left(\tan^{-1}x - \frac{\pi}{4}\right)^2; 0 \leq \left(\tan^{-1}x - \frac{\pi}{4}\right)^2 \leq \frac{\pi^2}{16}$   
 as  $x > 0$ ,  $\frac{\pi^3}{32} \leq A < \frac{\pi^3}{8}$

42. The maximum value of  $B$  is  
 (a)  $\frac{\pi^2}{8}$  (b)  $\frac{\pi^2}{16}$   
 (c)  $\frac{\pi^2}{4}$  (d) None of these

**Solution:** (c) Given  $B = (\sin^{-1}t)^2 + (\cos^{-1}t)^2$   
 $\Rightarrow B = (\sin^{-1}t + \cos^{-1}t)^2 - 2\sin^{-1}t \cos^{-1}t$   
 $\Rightarrow B = \frac{\pi^2}{4} - 2\sin^{-1}t \left(\frac{\pi}{2} - \sin^{-1}t\right)$   
 $\Rightarrow B = \frac{\pi^2}{8} + 2\left(\sin^{-1}t - \frac{\pi}{4}\right)^2$   
 $B_{\max} = \frac{\pi^2}{8} + 2 \cdot \frac{\pi^2}{16} = \frac{\pi^2}{4}$

43. If least value of  $A$  is  $\lambda$  and maximum value of  $B$   
 is  $\mu$ , then  $\cot^{-1} \cot\left(\frac{\lambda - \mu\pi}{\mu}\right)$  is equal to  
 (a)  $\frac{\pi}{8}$  (b)  $-\frac{\pi}{8}$   
 (c)  $\frac{7\pi}{8}$  (d)  $-\frac{7\pi}{8}$

**Solution:** (a)  $\lambda = \frac{\pi^3}{32}$ ,  $\mu = \frac{\pi^2}{4}$   
 $\Rightarrow \frac{\lambda}{\mu} = \frac{\pi}{8}$

$$\Rightarrow \frac{\lambda - \mu\pi}{\mu} = \frac{\pi}{8} - \pi = \frac{-7\pi}{8}$$

$$\Rightarrow \cot^{-1}\cot\left(\frac{\lambda - \mu\pi}{\mu}\right) = \cot^{-1}\cot\left(-\frac{7\pi}{8}\right) = \frac{\pi}{8}$$

**Assertion Reason type**

- (a) If both assertion and reason are correct and reason is the correct explanation of the assertion.
- (b) If both assertion and reason are correct but reason is not correct explanation of the assertion.
- (c) If assertion is correct, but reason is incorrect
- (d) If assertion is incorrect, but reason is correct

**44. Statement 1:**  $\operatorname{cosec}^{-1}\left(\frac{1}{2} + \frac{1}{\sqrt{2}}\right) > \sec^{-1}\left(\frac{1}{2} + \frac{1}{\sqrt{2}}\right)$

**Statement 2:**  $\operatorname{cosec}^{-1}x > \sec^{-1}x$  if  $1 \leq x < \sqrt{2}$

**Solution:** (a)  $\operatorname{cosec}^{-1}x > \sec^{-1}x$

$$\Rightarrow \operatorname{cosec}^{-1}x > \frac{\pi}{2} - \operatorname{cosec}^{-1}x \Rightarrow \operatorname{cosec}^{-1}x > \frac{\pi}{4}$$

$$1 \leq x < \sqrt{2} \text{ and } \left(\frac{1}{2} + \frac{1}{\sqrt{2}}\right) \in [1, \sqrt{2})$$

Statement 2 is true and explains statement 1

**45. Statement 1:**  $\sec^{-1}5 < \tan^{-1}5 < \tan^{-1}7$

**Statement 2:**  $\sec^{-1}x < \tan^{-1}x$  if  $x \geq 1$ ,  $\sec^{-1}x > \tan^{-1}x$  if  $x \leq -1$  and  $\tan^{-1}x_1 > \tan^{-1}x_2$  if  $x_1 > x_2$

**Solution:** (a)  $\tan^{-1}x$  is an increasing function by definition  $\sec^{-1}x = \tan^{-1}\sqrt{x^2 - 1}$  for  $x \geq 1$

$$\therefore \sec^{-1}x < \tan^{-1}x \text{ if } \tan^{-1}\sqrt{x^2 - 1} < \tan^{-1}x$$

$$\text{If } \sqrt{x^2 - 1} < x \text{ if } x^2 - 1 < x^2 \text{ which is true}$$

Also for  $x \leq -1$ ;

$$\sec^{-1}x \in \left(\frac{\pi}{2}, \pi\right] \text{ and } \tan^{-1}x \in \left(-\frac{\pi}{2}, -\frac{\pi}{4}\right]$$

$$\Rightarrow \sec^{-1}x > \tan^{-1}x$$

$\therefore$  Statement -2 is true

Statement -1  $\sec^{-1}5 < \tan^{-1}5 < \tan^{-1}7$  holds by statement-2

**Column Matching Type questions**

**46. Column-I**

- (a) If  $x > 1$ , then  $\sec(\operatorname{cosec}^{-1}x)$  is equal to
- (b) If  $x < -1$ , then  $\sec(\operatorname{cosec}^{-1}x)$  is equal to
- (c) If  $x > 1$ , then  $\operatorname{cosec}(\sec^{-1}x)$  is equal to
- (d) If  $x < -1$ , then  $\operatorname{cosec}(\sec^{-1}x)$  is equal to

**Column-II**

(p)  $\frac{x}{\sqrt{x^2 - 1}}$

(q)  $\frac{-x}{\sqrt{x^2 - 1}}$

(r)  $\frac{1}{\sqrt{x^2 - 1}}$

(s) Not defined

**Ans.** (a)  $\rightarrow$  (p); (b)  $\rightarrow$  (q);

(c)  $\rightarrow$  (p); (d)  $\rightarrow$  (q)

For (a) and (b)  $\sec(\operatorname{cosec}^{-1}x)$

**Solution:** Let  $\operatorname{cosec}^{-1}x = \theta$ , then  $x = \operatorname{cosec}\theta$ ,  $-\frac{\pi}{2} \leq \theta < 0$  or  $0 < \theta \leq \frac{\pi}{2}$

$$\therefore \sec\theta = \sqrt{1 + \tan^2\theta} = \sqrt{1 + \frac{1}{\cot^2\theta}} =$$

$$\sqrt{1 + \frac{1}{\operatorname{cosec}^2\theta - 1}}, \theta \neq \pm \frac{\pi}{2}$$

$$= \sqrt{1 + \frac{1}{x^2 - 1}}, x \neq \pm 1 = \frac{|x|}{\sqrt{x^2 - 1}}; x \neq \pm 1$$

$$\therefore \sec(\operatorname{cosec}^{-1}x) = \begin{cases} \frac{x}{\sqrt{x^2 - 1}}, & x > 1 \\ \frac{-x}{\sqrt{x^2 - 1}}, & x < -1 \end{cases}$$

For (c), (d)  $\operatorname{cosec}(\sec^{-1}x)$

Let  $\sec^{-1}x = \theta$ ,

$$\text{then } x = \sec\theta, 0 \leq \theta < \frac{\pi}{2}$$

$$\text{or } \frac{\pi}{2} < \theta \leq \pi$$

$$\therefore \operatorname{cosec}\theta = \sqrt{1 + \cot^2\theta} = \sqrt{1 + \frac{1}{\tan^2\theta}}$$

$$= \sqrt{1 + \frac{1}{\sec^2\theta - 1}}; \theta \neq 0, \pi$$

$$= \sqrt{1 + \frac{1}{x^2 - 1}}; x \neq \pm 1 = \frac{|x|}{\sqrt{x^2 - 1}}; x \neq \pm 1$$

$$\Rightarrow \operatorname{cosec}(\sec^{-1}x) = \begin{cases} \frac{x}{\sqrt{x^2 - 1}}, & x > 1 \\ \frac{-x}{\sqrt{x^2 - 1}}, & x < -1 \end{cases}$$

## SECTION-III

## OBJECTIVE TYPE (ONLY ONE CORRECT ANSWER)

1. If  $\sin^{-1} \left( -\frac{x^2}{2} + \frac{x^3}{4} - \dots \right) + \cos^{-1} \left( x^2 - \frac{x^4}{2} + \frac{x^6}{4} - \dots \right)$   
 $= \frac{\pi}{2}$  for  $0 < |x| < \sqrt{2}$ , then  $x$  equals  
 (a)  $\frac{1}{2}$  (b) 1  
 (c)  $-\frac{1}{2}$  (d) -1
2.  $\cos(\sec^{-1}(\cos x))$  is real, if  
 (a)  $x \in [-1, 1]$   
 (b)  $x \in R$   
 (c)  $x$  is an odd multiple of  $\frac{\pi}{2}$   
 (d)  $x$  is a multiple of  $\pi$
3.  $\tan \left( \frac{\pi}{4} + \frac{1}{2} \cos^{-1} x \right) + \tan \left( \frac{\pi}{4} - \frac{1}{2} \cos^{-1} x \right)$ ,  $x \neq 0$ , is  
 equal to  
 (a)  $x$  (b)  $2x$   
 (c)  $\frac{2}{x}$  (d) None of these
4. The set of values of  $k$  for which  $x^2 - kx + \sin^{-1}(\sin 4) > 0$  for all real  $x$  is  
 (a)  $\phi$  (b)  $(-2, 2)$   
 (c)  $R$  (d) None of these
5.  $2(\tan^{-1} 1 + \tan^{-1} 2 + \tan^{-1} 3)$  is equal to  
 (a)  $\pi/4$  (b)  $\pi/2$   
 (c)  $\pi$  (d)  $2\pi$
6. The value of  $\tan^{-1} \frac{a}{b} - \tan^{-1} \frac{a-b}{a+b}$  for  $|a| < |b|$  is  
 (a)  $\frac{\pi}{3}$  (b)  $\frac{\pi}{4}$   
 (c)  $\frac{\pi}{6}$  (d) 0
7. Solution of the equation  $2\tan^{-1}(\cos x) = \tan^{-1}(2 \operatorname{cosec} x)$  is  
 (a)  $x = 2n\pi + \frac{\pi}{4}; n \in \mathbb{Z}$   
 (b)  $x = n\pi + \frac{\pi}{4}; n \in \mathbb{Z}$   
 (c)  $x = n\pi + \frac{\pi}{2}; n \in \mathbb{Z}$   
 (d) None of these
8. If  $f(x) = \sin^{-1} \left\{ \frac{\sqrt{3}}{2}x - \frac{1}{2}\sqrt{1-x^2} \right\}$ ,  $-\frac{7}{2} \leq x \leq 1$ , then  
 $f(x)$  is equal to  
 (a)  $\sin^{-1} \frac{1}{2} - \sin^{-1} x$  (b)  $\sin^{-1} x - \frac{\pi}{6}$   
 (c)  $\sin^{-1} x + \frac{\pi}{6}$  (d) None of these
9. The value of  
 $\sin^{-1} \left[ \cos \left( \sin^{-1} \sqrt{\frac{2-\sqrt{3}}{4}} + \cos^{-1} \frac{\sqrt{12}}{4} + \sec^{-1} \sqrt{2} \right) \right]$  is.  
 (a) 0 (b)  $\frac{\pi}{4}$   
 (c)  $\frac{\pi}{6}$  (d)  $\frac{\pi}{2}$
10. The maximum value of  $(\sec^{-1}x)^2 + (\operatorname{cosec}^{-1}x)^2$  is equal to  
 (a)  $\frac{\pi^2}{2}$  (b)  $\frac{5\pi^2}{4}$   
 (c)  $\pi^2$  (d) None of these
11. If  $[\sin^{-1} \cos^{-1} \sin^{-1} \tan^{-1} x] = 1$ , where  $[\cdot]$  denotes the  
 greatest integer function, then  $x$  belongs to the interval  
 (a)  $(\tan \sin \cos \sin 1, \tan \sin \cos \sin 2]$   
 (b)  $[\tan \sin \cos 1, \tan \sin \cos \sin 1]$   
 (c)  $[1, -1]$   
 (d)  $[\sin \cos \tan 1, \sin \cos \sin \tan 1]$
12. Number of solutions of the equation  $\sin^{-1}x + \sin^{-1}(1-x^2) = \cos^{-1}x + \cos^{-1}(1-x^2)$  is  
 (a) 2 (b) 3  
 (c) 0 (d) 1
13. If  $\tan^{-1}x + \tan^{-1}y + \tan^{-1}z = \pi$  or  $\frac{\pi}{2}$ , then  
 (a)  $x + y + z = 3xyz$  (b)  $x + y + z = 2xyz$   
 (c)  $xy + zx + yz = 1$  (d) None of these
14.  $\cot^{-1} \frac{xy+1}{x-y} + \cot^{-1} \frac{yz+1}{y-z} + \cot^{-1} \frac{zx+1}{z-x}$ ;  $x > y > z > 0$   
 and  $x, y, z$  distinct is equal to  
 (a) 0  
 (b) 1  
 (c)  $\cot^{-1} x + \cot^{-1} y + \cot^{-1} z$   
 (d) None of these

15. If  $\tan^{-1} \frac{a+x}{a} + \tan^{-1} \frac{a-x}{a} = \frac{\pi}{6}$ , then  $x^2$  is equal to

- (a)  $2\sqrt{3}a$  (b)  $\sqrt{3}a$   
 (c)  $2\sqrt{3}a^2$  (d) None of these

16. If  $\tan^{-1} \frac{c_1 x - y}{c_1 y + x} + \tan^{-1} \frac{c_2 - c_1}{1 + c_2 c_1} + \tan^{-1} \frac{c_3 - c_2}{1 + c_3 c_2} + \dots$

upto  $n$  terms = 0;  $x, y, c_p, c_j > 0$  then  $\tan^{-1} \frac{1}{c_n}$  is equal to

- (a)  $\tan^{-1} \frac{y}{x}$  (b)  $\tan^{-1} yx$   
 (c)  $\tan^{-1} \frac{x}{y}$  (d)  $\tan^{-1}(x - y)$

17. The number of real solutions of the equation  $\sqrt{1 + \cos 2x} = \sqrt{2} \sin^{-1}(\sin x)$ ,  $-\pi \leq x \leq \pi$  is

- (a) 0 (b) 1  
 (c) 2 (d) infinite

18. The number of real solutions  $(x, y)$  where  $|y| = \sin x$ ,  $y = \cos^{-1}(\cos x)$ ,  $-2\pi \leq x \leq 2\pi$ , is

- (a) 2 (b) 1  
 (c) 3 (d) 4

19. Value of  $\sum_{r=0}^{\infty} \tan^{-1} \left( \frac{1}{1+r+r^2} \right)$  is equal to

- (a)  $\frac{\pi}{2}$  (b)  $\frac{3\pi}{4}$   
 (c)  $\frac{\pi}{4}$  (d) None of these

20.  $\cos^{-1} \left( \frac{1}{2} x^2 + \sqrt{1-x^2} \sqrt{1-\frac{x^2}{4}} \right) = \cos^{-1} \frac{x}{2} - \cos^{-1} x$  holds

- for  
 (a)  $|x| \leq 1$  (b)  $x \in R$   
 (c)  $0 \leq x \leq 1$  (d)  $-1 \leq x < 0$

21. Total number of positive integral value of 'n' so that the equations  $\cos^{-1} x + (\sin^{-1} y)^2$  is equal to

$\frac{n\pi^2}{4}$  and  $(\sin^{-1} y)^2 - \cos^{-1} x = (\sin^{-1} y)^2 - \cos^{-1} x = \frac{\pi^2}{16}$

- are consistent, is equal to  
 (a) 1 (b) 4  
 (c) 3 (d) 2

22.  $\sum_{r=1}^n \left\{ \sin^{-1} \left( \frac{1}{\sqrt{r+1}} \right) - \sin^{-1} \left( \frac{1}{\sqrt{r}} \right) \right\}$  is equal to

- (a)  $\tan^{-1}(\sqrt{n}) - \frac{\pi}{2}$  (b)  $\tan^{-1}(\sqrt{n+1}) - \frac{\pi}{4}$   
 (c)  $\tan^{-1}(\sqrt{n})$  (d)  $\tan^{-1}(\sqrt{n+1})$

23. The complete solution set of  $[\cot^{-1} x]^2 - 6[\cot^{-1} x] + 9 \leq 0$ , where  $[.]$  denotes the greatest integer function, is

- (a)  $(-\infty, \cot 3]$  (b)  $[\cot 3, \cot 2]$   
 (c)  $[\cot 3, \infty]$  (d) None of these

24. If  $[\sin^{-1} x] + [\cos^{-1} x] = 0$  where 'x' is a non negative real number and  $[.]$  denotes the greatest integer function, then complete set of values of x is

- (a)  $(\cos 1, 1)$  (b)  $(-1, \cos 1)$   
 (c)  $(\sin 1, 1)$  (d)  $(\cos 1, \sin 1)$

25. Complete set of values of x satisfying  $[\tan^{-1} x] + [\cot^{-1} x] = 2$  where  $[.]$  denotes the greatest integer function, is

- (a)  $(\cot 2, \cot 3)$  (b)  $(\cot 3, -\tan 1)$   
 (c)  $(\cot 3, 0)$  (d) None of these

26.  $\sin^{-1}(\cos(\sin^{-1} x)) + \cos^{-1}(\sin(\cos^{-1} x))$  is equal to

- (a)  $\frac{\pi}{4}$  (b)  $\frac{\pi}{2}$   
 (c)  $\frac{3\pi}{4}$  (d) 0

27. If  $x^2 + y^2 + z^2 = r^2$ ;  $x, y, z, r > 0$ , then

$\tan^{-1} \left( \frac{xy}{zr} \right) + \tan^{-1} \left( \frac{yz}{xr} \right) + \tan^{-1} \left( \frac{zx}{yr} \right)$  is equal to

- (a)  $\pi$  (b)  $\frac{\pi}{2}$   
 (c) 0 (d) None of these

28. If  $\sin^{-1} a + \sin^{-1} b + \sin^{-1} c = \pi$ , then the value of

$a\sqrt{1-a^2} + b\sqrt{1-b^2} + c\sqrt{1-c^2}$  will be

- (a)  $2abc$  (b)  $abc$   
 (c)  $\frac{1}{2} abc$  (d)  $\frac{1}{3} abc$

29.  $\cos^{-1} \sqrt{\frac{a-x}{a-b}} = \sin^{-1} \sqrt{\frac{x-b}{a-b}}$  is possible if

- (a)  $a > x > b$  (b)  $a < x < b$   
 (c)  $a = x = b$  (d)  $a > b, x \in R$

30. If  $x_1 = 2\tan^{-1} \left( \frac{1+x}{1-x} \right)$ ,  $x_2 = \sin^{-1} \left( \frac{1-x^2}{1+x^2} \right)$ ; where  $x \in (0, 1)$  then  $x_1 + x_2$  is equal to

- (a) 0 (b)  $2\pi$   
 (c)  $\pi$  (d) None of these

31. If  $\alpha \in \left( -\frac{3\pi}{2}, -\pi \right)$ , then the value of  $\tan^{-1}(\cot \alpha) - \cot^{-1}(\tan \alpha) + \sin^{-1}(\sin \alpha) + \cos^{-1}(\cos \alpha)$  is equal to:

- (a)  $2\pi + \alpha$  (b)  $\pi + \alpha$   
 (c) 0 (d)  $\pi - \alpha$

32. If  $z = \sec^{-1}\left(x + \frac{1}{x}\right) + \sec^{-1}\left(y + \frac{1}{y}\right)$ , where  $xy > 0$ , then the value of  $z$  (among the given values) is not possible:
- (a)  $\frac{5\pi}{6}$  (b)  $\frac{7\pi}{10}$   
 (c)  $\frac{9\pi}{10}$  (d)  $\frac{5\pi}{3}$
33. The number of solution of equation  $\pi \cot^{-1}(x-1) + (\pi-1) \cot^{-1}x = 2\pi - 1$
- (a) 0 (b) 1  
 (c) 2 (d) 3
34. If  $x \in [-1, 0)$  then  $\cos^{-1}(2x^2 - 1) - 2 \sin^{-1}x$  equals
- (a)  $-\frac{\pi}{2}$  (b)  $\frac{3\pi}{2}$   
 (c)  $-2\pi$  (d) None of these
35. If  $x \in \left(\frac{3\pi}{2}, 2\pi\right)$  then value of the expression  $\sin^{-1}(\cos(\cos^{-1}(\cos x) + \sin^{-1}(\sin x)))$  equals
- (a)  $-\frac{\pi}{2}$  (b)  $\frac{\pi}{2}$   
 (c) 0 (d) None of these
36. Which of the following is negative
- (a)  $\cos(\tan^{-1}(\tan 4))$  (b)  $\sin(\cot^{-1}(\cot 4))$   
 (c)  $\tan(\cos^{-1}(\cos 5))$  (d)  $\cot(\sin^{-1}(\sin 4))$
37. If  $x_1, x_2, x_3, x_4$  are roots of the equation  $x^4 - x^3 \sin 2\beta + x^2 \cos 2\beta - x \cos \beta - \sin \beta = 0$  then  $\sum_{i=1}^4 \tan^{-1} x_i$  is equal to
- (a)  $\pi - \beta$  (b)  $\pi - 2\beta^{-1}$   
 (c)  $\pi/2 - \beta$  (d)  $\pi/2 - 2\beta$
38. The inequality  $\log_2(x) < \sin^{-1}(\sin(5))$  holds if  $x \in$
- (a)  $(0, 2^{5-2\pi})$  (b)  $(2^{5-2\pi}, \infty)$   
 (c)  $(2^{2\pi-5}, \infty)$  (d)  $(0, 2^{2\pi-5})$
39. If  $\sin^{-1}x + \sin^{-1}y + \sin^{-1}z = \frac{3\pi}{2}$  and  $f(1) = 2$ ,  $f(p+q) = f(p) \cdot f(q) \forall p, q \in \mathbb{R}$ , then  $x^{f(1)} + y^{f(2)} + z^{f(2)} - \frac{x+y+z}{x^{f(1)} + y^{f(2)} + z^{f(3)}} =$
- (a) 0 (b) 1  
 (c) 2 (d) 3
40. If  $\tan^{-1}x + \cos^{-1}\frac{y}{\sqrt{1+y^2}} = \sin^{-1}\frac{3}{\sqrt{10}}$  where  $x$  and  $y$  are +ve integer, then number of possible pair of  $(x, y)$  is:
- (a) 1 (b) 2  
 (c) 3 (d) 4
41. If  $x > 0, y > 0$  and  $x > y$ , then  $\tan^{-1}(x/y) + \tan^{-1}[(x+y)/(x-y)]$  is equal to:
- (a)  $-\pi/4$  (b)  $\pi/4$   
 (c)  $3\pi/4$  (d) None of these
42. The inequality  $\sin^{-1}(\sin 5) > x^2 - 4x$  holds if
- (a)  $x = 2 - \sqrt{9-2\pi}$   
 (b)  $x = 2 + \sqrt{9-2\pi}$   
 (c)  $x \in (2 - \sqrt{9-2\pi}, 2 + \sqrt{9-2\pi})$   
 (d)  $x > 2 + \sqrt{9-2\pi}$
43. The value of  $\cos^{-1}\frac{\sqrt{2}}{\sqrt{3}} - \cos^{-1}\frac{\sqrt{6}+1}{2\sqrt{3}}$  is equal to
- (a)  $\frac{\pi}{12}$  (b)  $\frac{\pi}{8}$   
 (c)  $\frac{\pi}{6}$  (d)  $\frac{\pi}{3}$
44. If  $\frac{1}{\sqrt{2}} < x < 1$  then  $\cos^{-1}x + \cos^{-1}\left(\frac{x + \sqrt{1-x^2}}{\sqrt{2}}\right)$  is equal to
- (a)  $2 \cos^{-1}x - \frac{\pi}{4}$  (b)  $2 \cos^{-1}x$   
 (c)  $\frac{\pi}{4}$  (d) 0
45. The set values of  $x$  for which the equation  $\cos^{-1}x + \cos^{-1}\left(\frac{x}{2} + \frac{1}{2}\sqrt{3-3x^2}\right) = \frac{\pi}{3}$  holds good, is:
- (a)  $[0, 1]$  (b)  $\left[0, \frac{1}{2}\right]$   
 (c)  $\left[\frac{1}{2}, 1\right]$  (d)  $\{-1, 0, 1\}$
46. The no. of pair of solutions  $(x, y)$  of equation  $1 + x^2 + 2x \sin(\cos^{-1}y) = 0$  is/are
- (a) 4 (b) 3  
 (c) 2 (d) 1
47. Number of solution of equation  $\sin^{-1}x + n \sin^{-1}(1-x) = \frac{m\pi}{2}$  where  $n > 0, m \leq 0$  is:
- (a) 3 (b) 1  
 (c) 2 (d) None of these
48. Equation of the image of the line  $x + y = \sin^{-1}(a^3 + 1) + \cos^{-1}(a^2 + 1) - \tan^{-1}(a + 1)$ ,  $a \in \mathbb{R}$  about  $y$ -axis is given by
- (a)  $x - y + \frac{\pi}{4} = 0$  (b)  $x - y = 0$   
 (c)  $x - y = \frac{\pi}{4}$  (d)  $x - y = \frac{\pi}{2}$



4.90 > Trigonometry

49.  $\operatorname{cosec}^{-1}(\operatorname{cosec} x)$  and  $\operatorname{cosec}(\operatorname{cosec}^{-1}x)$  are equal functions then maximum range of value of  $x$  is -

- (a)  $\left[-\frac{\pi}{2}, -1\right] \cup \left[1, \frac{\pi}{2}\right]$   
 (b)  $\left[-\frac{\pi}{2}, 0\right) \cup \left[0, \frac{\pi}{2}\right]$   
 (c)  $(-\infty, -1] \cup [1, \infty)$   
 (d)  $[-1, 0) \cup [0, 1]$

50. If  $\cos^{-1} p + \cos^{-1} q + \cos^{-1} r = \pi$ . Then value of  $p^2 + q^2 + r^2 + 2pqr + 4$  is equal to-

- (a) 1 (b) 0  
 (c) 5 (d) 3

51. The number of real solution of  $\tan^{-1} \sqrt{x(x+1)} + \sin^{-1} \sqrt{x^2 + x + 1} = \frac{\pi}{2}$  is

- (a) zero (b) one  
 (c) two (d) infinite

## SECTION-IV

### OBJECTIVE TYPE (MORE THAN ONE CORRECT ANSWERS)

1. Indicate the relation which is true.

- (a)  $\tan |\tan^{-1}x| = |x|$   
 (b)  $\cot |\cot^{-1}x| = x$   
 (c)  $\tan^{-1} |\tan x| = |x|$   
 (d)  $\sin |\sin^{-1} x| = |x|$

2. The value of  $f(x) = \tan \left\{ \frac{1}{2} \sin^{-1} \frac{2x}{1+x^2} + \frac{1}{2} \cos^{-1} \frac{1-x^2}{1+x^2} \right\}$  is

- (a)  $f(x) = \frac{2x}{1-x^2}$  if  $0 \leq x < 1$   
 (b)  $f(x) = \frac{2x}{1-x^2}$  if  $x < 1$   
 (c) not finite if  $x > 1$   
 (d) None of these

3. If  $\tan^{-1} y = 4 \tan^{-1} x$ , then  $y$  is not finite if

- (a)  $x^2 = 3 + 2\sqrt{2}$  (b)  $x^2 = 3 - 2\sqrt{2}$   
 (c)  $x^4 = 6x^2 - 1$  (d)  $x^4 = 6x^2 + 1$

4. If the equation  $\sin^{-1}(x^2 + x + 1) + \cos^{-1}(ax + 1) = \frac{\pi}{2}$  has exactly two solutions, then  $a$  can not have the integral value

- (a) -1 (b) 0  
 (c) 1 (d) 2

5. The value (s) of  $x$  satisfying the equation  $\sin^{-1} |\sin x| = \sqrt{|\sin^{-1} |\sin x|}$  is/are given by ( $n$  is any integer)

- (a)  $n\pi$  (b)  $n\pi + 1$   
 (c)  $n\pi - 1$  (d)  $2n\pi + 1$

6. If  $\tan^{-1}(\sin^2\theta + 2\sin\theta + 2) + \cot^{-1}(4^{\sec^2\theta} + 1) = \frac{\pi}{2}$  has solution for some  $\theta$  and  $\phi$  then

- (a)  $\sin \theta = -1$  (b)  $\sin \theta = 1$   
 (c)  $\cos \phi = 1$  (d)  $\cos \phi = -1$

7. If  $\tan^{-1}\left(\frac{a}{x}\right) + \tan^{-1}\left(\frac{b}{x}\right) = \frac{\pi}{2}$ , then  $x$

- (a)  $\sqrt{ab}$  for  $a, b > 0$  (b)  $-\sqrt{ab}$   
 (c)  $2ab$  (d) does not exist for  $a, b < 0$

8. If  $2\tan^{-1} x + \sin^{-1} \frac{2x}{1+x^2}$  is independent of  $x$ , then

- (a)  $x \in [1, \infty)$  (b)  $x \in [-1, 1]$   
 (c)  $x \in (-\infty, -1]$  (d) None of these

9. If  $f(x) = \sin^{-1} x \cdot \cos^{-1} x \cdot \tan^{-1} x \cdot \cot^{-1} x \cdot \sec^{-1} x \cdot \operatorname{cosec}^{-1} x$ , then which of the following statement(s) hold(s) good?

- (a) The graph of  $y = f(x)$  does not lie above  $x$  axis.  
 (b) The non-negative difference between maximum and minimum value of the function  $y = f(x)$  is  $\frac{3\pi^6}{64}$ .  
 (c) The function  $y = f(x)$  is not injective.  
 (d) Number of non-negative integers in the domain of  $f(x)$  is two.

10. Let  $f : \mathbb{R} \rightarrow \mathbb{R}$  defined by  $f(x) = \cos^{-1}(-\{ -x \})$  where  $\{x\}$  is fractional part function. Then which of the following is/are correct?

- (a)  $f$  is many one but not even function.  
 (b) Range of  $f$  contains two prime numbers.  
 (c)  $f$  is aperiodic.  
 (d) Graph of  $f$  does not lie below  $x$ -axis.

11. If  $(\sin^{-1} x)^2 + (\sin^{-1} y)^2 + (\sin^{-1} z)^2 = \frac{3\pi^2}{4}$ , then the value of  $(x - y + z)$  can be

- (a) 1 (b) -1  
 (c) 3 (d) -3

12. In  $\triangle ABC$ , if  $\angle B = \sec^{-1}\left(\frac{5}{4}\right) + \operatorname{cosec}^{-1}\sqrt{5}$ ,  $\angle C = \operatorname{cosec}^{-1}\left(\frac{25}{7}\right) + \cot^{-1}\left(\frac{9}{13}\right)$  and  $c = 3$ . Which of the following statement(s) is/are correct? (where all symbols used have their usual meanings in a triangle)
- (a)  $\tan A, \tan B, \tan C$  are in arithmetic progression.  
 (b) The distance between orthocentre and centroid of  $\triangle ABC$  is  $\frac{5}{3}$ .  
 (c) Area of  $\triangle ABC$  is irrational.
- (d) Radius of escribed circle drawn opposite to vertex A is rational.
13. The value(s) of  $x$  satisfying the equation  $\sin^{-1} |\sin x| = \sqrt{\sin^{-1} |\sin x|}$  is/are given by ( $n$  is any integer)
- (a)  $n\pi$  (b)  $n\pi + 1$   
 (c)  $n\pi - 1$  (d)  $2n\pi + 1$
14. If  $\tan^{-1}(\sin^2\theta + 2\sin\theta + 2) + \cot^{-1}(4^{\sec^2\phi} + 1) = \frac{\pi}{2}$  has solution for some  $\theta$  and  $\phi$  then
- (a)  $\sin\theta = -1$  (b)  $\sin\theta = 1$   
 (c)  $\cos\phi = 1$  (d)  $\cos\phi = -1$

## SECTION-V

### ASSERTION AND REASON TYPE QUESTIONS

The questions given below consist of an assertion (A) and the reason (R). Use the following key to choose the appropriate answer.

- (a) If both assertion and reason are correct and reason is the correct explanation of the assertion.  
 (b) If both assertion and reason are correct but reason is not correct explanation of the assertion.  
 (c) If assertion is correct, but reason is incorrect  
 (d) If assertion is incorrect, but reason is correct

Now consider the following statements:

1. **A:**  $\sin^{-1} \sin\left(\frac{2\pi}{3}\right) = \frac{\pi}{3}$ .

**R:**  $\sin^{-1} \sin\theta = \theta$ ; where  $\theta \in \left[-\frac{\pi}{2}, \frac{\pi}{2}\right]$ .

2. **A:**  $\cos^{-1} x + \cos^{-1} y = \cos^{-1}(xy - \sqrt{1-x^2}\sqrt{1-y^2})$ .  
 If  $x, y > 0$ .

**R:**  $\cos(\cos^{-1} x) = x$  when  $x \in [-1, 1]$

3. **A:** The value of  $\tan^{-1}(1) + \cos^{-1}\left(-\frac{1}{2}\right) + \sin^{-1}\left(-\frac{1}{2}\right)$  is equal to  $\frac{3\pi}{4}$ .

**R:**  $\tan^{-1} x + \cot^{-1} x = \pi/2$

4. **A:** If  $\tan^{-1} 2 + \tan^{-1} 3 = \frac{3\pi}{4}$ .

**R:**  $\tan^{-1} x + \tan^{-1} y = \tan^{-1}\left(\frac{x+y}{1-xy}\right)$ , where  $x > 0, y > 0$  and  $xy > 1$ .

5. **A:**  $\cot^{-1}(-x) = \pi - \cot^{-1} x$ .

**R:** The range of  $\cot^{-1} x$  is  $(0, \pi)$ .

6. **A:**  $\cot^{-1} 2 + \cot^{-1} 8 + \cot^{-1} 18 + \cot^{-1} 32 + \dots$  is equal to  $\pi/4$ .

**R:** The sum of the infinite series is always equal to  $\pi/4$

7. **A:** Equations  $2\sin^{-1} x + 3\sin^{-1} y = \frac{5\pi}{2}$  and  $y = kx - 5$  hold simultaneously when  $k$  is equal to 6.

**R:**  $\sin^{-1} x$  is continuous function in  $x \in [-1, 1]$

8. **A:** The value of  $\cos\left(\frac{1}{2}\cos^{-1}\frac{1}{8}\right)$  is equal to  $\frac{3}{8}$ .

**R:** The main point of the definition of inverse function is that if  $f$  is one-one and onto mapping then  $f^{-1}$  exist (as a function)

9. **A:**  $\sin^{-1}(\sin 3) = 3$

**R:** For principal values of  $x$   $\sin^{-1}(\sin x) = x$

10. **A:** If  $x < 0$ ,  $\tan^{-1} x + \tan^{-1}\left(\frac{1}{x}\right) = \frac{\pi}{2}$

**R:**  $\tan^{-1} x + \cot^{-1} x = \frac{\pi}{2}, \forall x \in R$ .

11. **A:** If  $x = \operatorname{cosec}(\tan^{-1}(\cos(\cot^{-1}(\sec(\sin^{-1} a))))))$  and  $y = \sec(\cot^{-1}(\sin(\tan^{-1}(\operatorname{cosec}(\cos^{-1} a))))))$ , where  $a \in [0, 1]$ , then  $x = y$

**R:**  $\sin^{-1}\left(\frac{1}{x}\right) = \operatorname{cosec}^{-1} x \forall x \in (-\infty, -1] \cup [1, \infty)$ ,

$\cos^{-1}\left(\frac{1}{x}\right) = \sec^{-1} x, \forall x \in (-\infty, -1] \cup [1, \infty)$

$\tan^{-1}\left(\frac{1}{x}\right) = \begin{cases} \cot^{-1} x, & x > 0 \\ -\pi + \cot^{-1} x, & x < 0 \end{cases}$

4.92 > Trigonometry

12. A: The solution of system of equations

$$\cos^{-1} x + (\sin^{-1} y)^2 = \frac{p\pi^2}{4} \text{ and } (\cos^{-1} x) (\sin^{-1} y)^2 = \frac{\pi^4}{16}$$

is  $x = \cos \frac{\pi^2}{4}$  and  $y = \pm 1$ , for permissible integer values of  $p$ .

R: AM  $\geq$  GM for non-negative numbers.

13. A: If  $\sum_{i=1}^{2n} \sin^{-1} x_i = n\pi$   $n \in \mathbb{N}$ . Then,

$$\sum_{i=1}^n x_i = \sum_{i=1}^n x_i^2 = \sum_{i=1}^n x_i^3$$

R:  $-\frac{\pi}{2} \leq \sin^{-1} x \leq \frac{\pi}{2}, \forall x \in [-1, 1]$ .

## SECTION-VI

### LINKED COMPREHENSION TYPE QUESTIONS

A: The inverse of a circular function  $f: A \rightarrow B$  exists iff  $f$  is one-one onto function (bijection) and given by  $f(x) = y$ . Thus  $f^{-1}(y) = x$ . Consider the sine function  $\sin x: \mathbb{R} \rightarrow \mathbb{R}$  which is a many one into function. So its inverse does not exist. If we restrict its domain  $\left[-\frac{\pi}{2}, \frac{\pi}{2}\right]$  and co-domain  $[-1, 1]$ , then  $\sin x$  would be one-one and onto and hence its inverse function would exist.

1. If  $\sin^{-1} \sin \theta = \pi - \theta$ , then  $\theta$  belonging to

- (a)  $\mathbb{R}$  (b)  $\left[0, \frac{\pi}{2}\right]$   
 (c)  $\left[\frac{\pi}{2}, \frac{3\pi}{2}\right]$  (d)  $[0, 2\pi]$

2. The trigonometric equation  $\sin^{-1} x = 2 \sin^{-1} y$  has a solution for

- (a)  $|y| \leq \frac{1}{2}$  (b)  $|y| \leq \frac{1}{\sqrt{2}}$   
 (c)  $\mathbb{R}$  (d)  $\frac{1}{\sqrt{2}} < |y| < 1$

3. The value of  $x$ , if  $2 \sin^{-1} x = \sin^{-1} (2x\sqrt{1-x^2})$  is

- (a)  $\left[-\frac{1}{\sqrt{2}}, 1\right]$  (b)  $\left[-\frac{1}{\sqrt{2}}, 1\right]$   
 (c)  $\left[-\frac{1}{\sqrt{2}}, \frac{1}{\sqrt{2}}\right]$  (d)  $\left(-\frac{1}{\sqrt{2}}, \frac{1}{\sqrt{2}}\right)$

B: While defining inverse trigonometric functions, a new system is followed where co-domains have been re-defined as follows:

Function	Domain	Co-domain
$\sin^{-1}x$	$[-1, 1]$	$\left[\frac{\pi}{2}, \frac{3\pi}{2}\right]$
$\cos^{-1}x$	$[-1, 1]$	$[\pi, 2\pi]$

$\tan^{-1}x$	$\mathbb{R}$	$\left(\frac{\pi}{2}, \frac{3\pi}{2}\right)$
$\cot^{-1}x$	$\mathbb{R}$	$(\pi, 2\pi)$

Based on above system, answer the following questions:

4.  $\sin^{-1}(-x)$  is equal to

- (a)  $-\sin^{-1}x$  (b)  $\pi + \sin^{-1}x$   
 (c)  $2\pi - \sin^{-1}x$  (d)  $3\pi - \cos^{-1}\sqrt{1-x^2}, x > 0$

5. If  $f(x) = 3\sin^{-1}x - 2\cos^{-1}x$ , then  $f(x)$  is.

- (a) even function  
 (b) odd function  
 (c) neither even nor odd  
 (d) even as well as odd function

6. The minimum of  $(\sin^{-1}x)^3 - (\cos^{-1}x)^3$  is equal to

- (a)  $-\frac{63}{8}\pi^3$  (b)  $\frac{63}{8}\pi^3$   
 (c)  $\frac{125\pi^3}{32}$  (d)  $-\frac{125\pi^3}{32}$

7. The value of  $\sin^{-1}x + \cos^{-1}x$  is equal to

- (a)  $\frac{\pi}{2}$  (b)  $\frac{3\pi}{2}$   
 (c)  $\frac{5\pi}{2}$  (d)  $\frac{7\pi}{2}$

8. If in another such system co-domain of  $\sin^{-1}x$  is  $\left[-\frac{5\pi}{2}, -\frac{3\pi}{2}\right]$  and  $\sin^{-1}x + \cos^{-1}x = \frac{5\pi}{2}$  then in the

- same system, co-domain of  $\cos^{-1}x$  is  
 (a)  $[4\pi, 5\pi]$  (b)  $[3\pi, 4\pi]$   
 (c)  $[6\pi, 7\pi]$  (d)  $[5\pi, 6\pi]$

9.  $\sec^2(\tan^{-1}2) + \operatorname{cosec}^2(\cot^{-1}3) + 2$  is equal to

- (a) 17 (b) 15  
 (c) 25 (d) 27



4.94 > Trigonometry

23. The sum of infinite terms of the series  $\cot^{-1}3 + \cot^{-1}7 + \cot^{-1}13 + \dots$  is

- (a)  $\frac{\pi}{2}$
- (b)  $\cot^{-1}2$
- (c)  $\tan^{-1}2$
- (d) None of these

24. The sum of infinite terms of the series

$$\tan^{-1}\left(\frac{2}{1-1^2+1^4}\right) + \tan^{-1}\left(\frac{4}{1-2^2+2^4}\right) + \tan^{-1}\left(\frac{6}{1-3^2+3^4}\right) + \dots$$

- (a)  $\frac{\pi}{4}$
- (b)  $\frac{\pi}{2}$
- (c)  $\frac{3\pi}{4}$
- (d) None of these

F: Let  $\alpha = \cos^{-1}\left(\frac{4}{5}\right)$  and  $\beta = \tan^{-1}\left(\frac{2}{3}\right)$ . Then

25.  $\alpha + \beta$  is

- (a)  $\tan^{-1}\left(\frac{17}{6}\right)$
- (b)  $\tan^{-1}\left(\frac{6}{17}\right)$
- (c)  $\tan^{-1}\left(\frac{7}{16}\right)$
- (d)  $\tan^{-1}\left(\frac{16}{7}\right)$

26.  $\alpha - \beta$  is

- (a)  $\tan^{-1}\left(-\frac{1}{18}\right)$
- (b)  $\tan^{-1}\left(\frac{1}{18}\right)$
- (c)  $\tan^{-1}\left(-\frac{1}{18}\right)$
- (d)  $\tan^{-1}(18)$

27.  $2\alpha$  is

- (a)  $\tan^{-1}\left(\frac{24}{7}\right)$
- (b)  $\tan^{-1}\left(\frac{7}{24}\right)$
- (c)  $\tan^{-1}\left(\frac{24}{25}\right)$
- (d)  $\tan^{-1}\left(\frac{25}{24}\right)$

## SECTION-VII

### MATRIX MATCH TYPE QUESTIONS

1. Column-I

- (i)  $\left(\tan^{-1}\frac{x}{3}\right)^2 - 4\tan^{-1}\frac{x}{3} - 5 = 0$
- (ii)  $[\tan^{-1}(3x+2)]^2 + 2\tan^{-1}(3x+2) = 0$
- (iii)  $3(\tan^{-1}x)^2 - 4\tan^{-1}x + \pi^2 = 0$

Column-II

- (a)  $x = -3 \tan 1$
- (b)  $x = \sqrt{3}$
- (c)  $x = -\frac{2}{3}$

2. Column-I

- (i) If  $\tan^{-1}x + \tan^{-1}y + \tan^{-1}z = \pi$ , then
- (ii) If  $\tan^{-1}x + \tan^{-1}y + \tan^{-1}z = \frac{\pi}{2}$ , then
- (iii) If  $\tan^{-1}x + \tan^{-1}y + \tan^{-1}z = \frac{\pi}{2}$  and  $x + y + z = \sqrt{3}$ , then

Column-II

- (a)  $x = y = z$
- (b)  $xyz \geq 3\sqrt{3}$
- (c)  $x + y + z = xyz$
- (d)  $xyz \leq \frac{1}{3\sqrt{3}}$
- (e)  $xy + yz + zx = 1$

3. Column-I

- (i) If principal values of  $\sin^{-1}\left(-\frac{1}{2}\right) + \tan^{-1}(\sqrt{3})$  and  $\cos^{-1}\left(-\frac{1}{2}\right)$  are  $\lambda$  and  $\mu$  respectively, then
- (ii) If principal values of  $\sin^{-1}\left(\sin\frac{7\pi}{6}\right)$  and  $\cos^{-1}\left\{-\sin\left(\frac{5\pi}{6}\right)\right\}$  are  $\lambda$  and  $\mu$  respectively then
- (iii) If principal values of  $\sin^{-1}\left(-\frac{\sqrt{3}}{2}\right)$  and  $\sin^{-1}\left\{\cos\left(\sin^{-1}\frac{\sqrt{3}}{2}\right)\right\}$  are  $\lambda$  and  $\mu$  respectively, then

**Column-II**

- (a)  $\lambda + \mu = \frac{\pi}{2}$   
 (b)  $\mu - \lambda = \frac{\pi}{2}$   
 (c)  $\lambda + \mu = -\frac{\pi}{6}$   
 (d)  $\mu - \lambda = \frac{5\pi}{6}$   
 (e)  $\lambda + \mu = \frac{5\pi}{6}$

**4. Column-I**

- (i) If  $2\tan^{-1}(2x+1) = \cos^{-1}(-x)$ , then  $x$  is  
 (ii) If  $2\cos^{-1}x = \sin^{-1}(2x\sqrt{1-x^2})$ , then  $x$  is  
 (iii) If  $\tan^{-1}\left(\frac{x-1}{x-2}\right) + \tan^{-1}\left(\frac{x+1}{x+2}\right) = \frac{\pi}{4}$ , then  $x$  is

**Column-II**

- (a)  $-\frac{1}{\sqrt{2}}$   
 (b) 0  
 (c)  $\frac{1}{\sqrt{2}}$   
 (d)  $\frac{\sqrt{3}}{2}$   
 (e) 1
5. Let  $(x, y)$  be such that  $\sin^{-1}(ax) + \cos^{-1}(y) + \cos^{-1}(bxy) = \frac{\pi}{2}$ ; then

**Column-I**

- (i) If  $a = 1$  and  $b = 0$ , then  $(x, y)$   
 (ii) If  $a = 1$  and  $b = 1$ , then  $(x, y)$   
 (iii) If  $a = 1$  and  $b = 2$ , then  $(x, y)$   
 (iv) if  $a = 2$  and  $b = 2$ , then  $(x, y)$

**Column-II**

- (a) lies on the circle  $x^2 + y^2 = 1$   
 (b) lies on  $(x^2 - 1)(y^2 - 1) = 0$   
 (c) lies on  $y = x$   
 (d) lies on  $(4x^2 - 1)(y^2 - 1) = 0$

## SECTION-VIII

### INTEGER TYPE QUESTIONS

1. The value of  $\sin^{-1}\left[\cos\left(\tan^{-1}\frac{1}{3} + \tan^{-1}\frac{1}{2}\right)\right]$  is  $\pi/k$ , then find the value of  $k$ .
2. The value of  $\tan\left\{\cos^{-1}\frac{4}{5} + \tan^{-1}\frac{2}{5}\right\}$  is  $\frac{\lambda}{\mu}$ ;  $(\lambda, \mu) = 1$ , then evaluate  $\frac{\lambda+19}{\mu}$ .
3. If two angles of a  $\Delta$  are  $\tan^{-1}\frac{1}{2}$  and  $\tan^{-1}1/3$ , then find  $\frac{\theta}{15}$  (where  $\theta$  is third angle of  $\Delta$  in degree).
4. If  $\cos^{-1}\sqrt{x-1} = \sin^{-1}\sqrt{2-x}$  holds  $\forall x \in [a, b]$ , then evaluate  $a + b$ .
5. If the area enclosed by  $y = \sin x$  and  $y = \sin^{-1}(\sin x)$   $\forall x \in [-2\pi, 2\pi]$  is  $\pi^2 - k$ , then evaluate  $k$ .
6. If the solution set of system of equations  $3\sin^{-1}x = -\pi - \sin^{-1}(3x - 4x^3)$  is  $[a, b]$  and that of  $3\sin^{-1}x = \pi - \sin^{-1}(3x - 4x^3)$  is  $[c, d]$  then evaluate  $|a| + |b| + |c| + |d|$
7.  $2\cos^{-1}x = \sin^{-1}(2x\sqrt{1-x^2})$ . If  $x \in [a, b]$ , then evaluate  $\frac{1+a^2b}{a^2}$ .
8.  $[\tan^{-1}x]^2 - 2[\tan^{-1}x] + 1 \leq 0$ , where  $[x]$  denotes greatest interger  $\leq x$ , iff  $x \in [\tan k, \tan 2)$  then evaluate  $k$ .
9. If the value of  $a = -\left(\frac{3\pi + \lambda}{\mu}\right)$  for which  $x^2 + ax + \sin^{-1}(x^2 - 4x + 5) + \cot^{-1}(x^2 - 4x + 5) = 0$  has a solution, then evaluate  $(\lambda - \mu)$ .
10. If  $m =$  number of positive integer solutions  $(x, y)$  of equation  $\tan^{-1}x + \cot^{-1}y = \tan^{-1}3$  and we have equation  $(1 + ax)^m = 1 + 8x + 24x^2 + \dots$ , then evaluate  $(2m - a)$ .
11. Find the number of solution of  $\cos(2\sin^{-1}(\cot(\tan^{-1}(\sec(6\operatorname{cosec}^{-1}x)))) + 1 = 0$ ; where  $x > 0$ .

**4.96** > Trigonometry

12. If  $\tan^{-1}n$ ,  $\tan^{-1}(n + 1)$  and  $\tan^{-1}(n + 2)$ ,  $n \in \mathbb{N}$ , are angles of a triangle, then find  $n$ .
13. Find the number of pair solution  $(x, y)$  of the equation  $1 + x^2 + 2x \sin(\cos^{-1} y) = 0$ .
14. Find the number of ordered pairs  $(x, y)$  satisfying  $|y| = \cos x$  and  $\sin^{-1}(\sin x)$ , where  $-2\pi \leq x \leq 3\pi$ .
15. If the range of  $m$  for which the equation  $\operatorname{cosec}^{-1} x = mx$  has exactly two solutions is  $\left(0, \frac{\lambda\pi}{10}\right]$  then, find  $\lambda$ .
16. If  $\tan^{-1} \left[ \frac{3 \sin 2\alpha}{5 + 3 \cos 2\alpha} \right] + \tan^{-1} \left[ \frac{\tan \alpha}{4} \right] = \frac{\lambda\alpha}{4}$ ; where  $-\frac{\pi}{2} < \alpha < \frac{\pi}{2}$ , then find  $\lambda$ .

## Answer Keys

### SECTION-III

- |         |         |         |         |         |         |         |         |         |         |
|---------|---------|---------|---------|---------|---------|---------|---------|---------|---------|
| 1. (b)  | 2. (d)  | 3. (c)  | 4. (a)  | 5. (d)  | 6. (b)  | 7. (b)  | 8. (b)  | 9. (a)  | 10. (b) |
| 11. (b) | 12. (a) | 13. (c) | 14. (a) | 15. (c) | 16. (c) | 17. (c) | 18. (c) | 19. (a) | 20. (c) |
| 21. (a) | 22. (a) | 23. (a) | 24. (d) | 25. (d) | 26. (b) | 27. (b) | 28. (a) | 29. (a) | 30. (c) |
| 31. (c) | 32. (d) | 33. (b) | 34. (d) | 35. (b) | 36. (d) | 37. (c) | 38. (a) | 39. (c) | 40. (b) |
| 41. (c) | 42. (c) | 43. (c) | 44. (c) | 45. (c) | 46. (d) | 47. (d) | 48. (a) | 49. (a) | 50. (c) |
| 51. (c) |         |         |         |         |         |         |         |         |         |

### SECTION-IV

- |                  |              |               |               |                 |
|------------------|--------------|---------------|---------------|-----------------|
| 1. (a, b, d)     | 2. (a, c)    | 3. (a, b, c)  | 4. (a, c, d)  | 5. (a, b, c, d) |
| 6. (b, c, d)     | 7. (a, b, c) | 8. (a, c,)    | 9. (a, b)     | 10. (a, b, d)   |
| 11. (a, b, c, d) | 12. (a, b)   | 13. (a, b, c) | 14. (a, c, d) |                 |

### SECTION-V

- |         |         |         |        |        |        |        |        |        |         |
|---------|---------|---------|--------|--------|--------|--------|--------|--------|---------|
| 1. (a)  | 2. (a)  | 3. (b)  | 4. (c) | 5. (a) | 6. (c) | 7. (b) | 8. (d) | 9. (d) | 10. (d) |
| 11. (b) | 12. (a) | 13. (a) |        |        |        |        |        |        |         |

### SECTION-VI

- |         |         |         |         |         |         |         |         |         |         |
|---------|---------|---------|---------|---------|---------|---------|---------|---------|---------|
| 1. (c)  | 2. (b)  | 3. (c)  | 4. (c)  | 5. (b)  | 6. (a)  | 7. (c)  | 8. (a)  | 9. (a)  | 10. (b) |
| 11. (c) | 12. (a) | 13. (c) | 14. (a) | 15. (d) | 16. (d) | 17. (d) | 18. (c) | 19. (c) | 20. (a) |
| 21. (d) | 22. (c) | 23. (d) | 24. (b) | 25. (a) | 26. (b) | 27. (a) |         |         |         |

### SECTION-VII

- |                 |                  |                   |
|-----------------|------------------|-------------------|
| 1. (i) → (a)    | (ii) → (c)       | (iii) → (b)       |
| 2. (i) → (b, c) | (ii) → (d, e)    | (iii) → (a, d, e) |
| 3. (i) → (b, e) | (ii) → (a, d)    | (iii) → (b, c)    |
| 4. (i) → (b, c) | (ii) → (c, d, e) | (iii) → (a, c)    |
| 5. (i) → (a, c) | (ii) → (b)       | (iii) → (a)       |
|                 |                  | (iv) → (d)        |

### SECTION-VIII

- |       |       |       |       |       |       |      |      |      |       |
|-------|-------|-------|-------|-------|-------|------|------|------|-------|
| 1. 4  | 2. 3  | 3. 9  | 4. 3  | 5. 8  | 6. 3  | 7. 3 | 8. 1 | 9. 8 | 10. 2 |
| 11. 3 | 12. 1 | 13. 1 | 14. 5 | 15. 5 | 16. 4 |      |      |      |       |

## HINTS AND SOLUTIONS

### TEXTUAL EXERCISE-1 (SUBJECTIVE)

1. Let principal value of angles be  $\theta$  then

(a)  $\sin^{-1}\left(-\frac{1}{2}\right) = \theta \in \left[-\frac{\pi}{2}, \frac{\pi}{2}\right]$   
 $\Rightarrow \sin \theta = -\frac{1}{2} \quad \Rightarrow \quad \theta = -\frac{\pi}{6}$

(b)  $\cos^{-1}\left(\frac{\sqrt{3}}{2}\right) = \theta \in [0, \pi]$   
 $\Rightarrow \cos \theta = \frac{\sqrt{3}}{2} \quad \Rightarrow \quad \theta = \frac{\pi}{6}$

(c)  $\operatorname{cosec}^{-1}(2) = \theta \in \left[-\frac{\pi}{2}, \frac{\pi}{2}\right] \sim \{0\}$   
 $\Rightarrow \operatorname{cosec} \theta = 2 \quad \Rightarrow \quad \theta = \frac{\pi}{6}$

(d)  $\tan^{-1}(-\sqrt{3}) = \theta \in \left(-\frac{\pi}{2}, \frac{\pi}{2}\right)$   
 $\Rightarrow \tan \theta = -\sqrt{3} \quad \Rightarrow \quad \theta = -\frac{\pi}{3}$

(e)  $\cos^{-1}\left(-\frac{1}{2}\right) = \theta \in [0, \pi]$   
 $\Rightarrow \cos \theta = -\frac{1}{2} \quad \Rightarrow \quad \theta = \frac{2\pi}{3}$

(f)  $\tan^{-1}(-1) = \theta \in \left(-\frac{\pi}{2}, \frac{\pi}{2}\right)$   
 $\Rightarrow \tan \theta = -1 \quad \Rightarrow \quad \theta = -\frac{\pi}{4}$

(g)  $\sec^{-1}\left(\frac{2}{\sqrt{3}}\right) = \theta \in [0, \pi] \sim \left\{\frac{\pi}{2}\right\}$   
 $\Rightarrow \sec \theta = \frac{2}{\sqrt{3}} \quad \Rightarrow \quad \cos \theta = \frac{\sqrt{3}}{2} \quad \Rightarrow \quad \theta = \frac{\pi}{6}$

(h)  $\cot^{-1}(-\sqrt{3}) = \theta \in (0, \pi)$   
 $\Rightarrow \cot \theta = -\sqrt{3} \quad \Rightarrow \quad \theta = \pi - \frac{\pi}{6} = \frac{5\pi}{6}$

2. (a)  $\tan^{-1}(1) + \cos^{-1}\left(-\frac{1}{2}\right) + \sin^{-1}\left(-\frac{1}{2}\right) = \frac{\pi}{4} + \frac{2\pi}{3} + \left(-\frac{\pi}{6}\right)$   
 $= \frac{3\pi + 8\pi - 2\pi}{12} = \frac{9\pi}{12} = \frac{3\pi}{4}$

(b)  $\cos^{-1}\left(\frac{1}{2}\right) + 2\sin^{-1}\left(\frac{1}{2}\right) = \frac{\pi}{3} + 2\left(\frac{\pi}{6}\right) = \frac{2\pi}{3}$

(c)  $\tan^{-1}(\sqrt{3}) - \sec^{-1}(-2) = \frac{\pi}{3} - \frac{2\pi}{3} = -\frac{\pi}{3}$

3.  $\because 0 \leq \cos^{-1}x_i \leq \pi$  thus  $\sum_{i=1}^k \cos^{-1}x_i \leq k\pi$

Equality possible iff  $\cos^{-1}x_i = \pi, \forall i = 1, 2, \dots, k$   
 $= -1 \forall i = 1, 2, \dots, k$

$\Rightarrow \sum_{i=1}^k x_i = \frac{(-1)k}{k} = -1$

4. Given  $\sum_{i=1}^n (\sin^{-1}x_i + \cos^{-1}y_i) = \frac{3n\pi}{2}$

$\because \sin^{-1}x_i \leq \frac{\pi}{2}$  and  $\cos^{-1}y_i \leq \pi \forall i = 1, 2, \dots, n$

Thus above equation holds iff  $\sin(x_i) = \frac{\pi}{2}$  and  $\cos^{-1}y_i = \pi \forall i$

$\Rightarrow x_i = 1$  and  $y_i = -1$  therefore,

(i)  $\sum_{i=1}^n x_i = \sum_{i=1}^n 1 = n$       (ii)  $\sum_{i=1}^n y_i = \sum_{i=1}^n -1 = -n$

(iii)  $\sum_{i=1}^n x_i y_i = \sum_{i=1}^n (-1) = -n$       (iv)  $\sum_{i=1}^n (x_i + y_i) = \sum_{i=1}^n 0 = 0$

(v)  $\sum_{1 \leq i < j \leq n} x_i y_j = \sum_{1 \leq i < j \leq n} -1 = -{}^n C_2 = -\frac{n(n-1)}{2}$

5. (i)  $f(x) = \sin^{-1}(2x + x^2)$  is defined iff  $-1 \leq 2x + x^2 \leq 1$

$\Rightarrow 0 \leq x^2 + 2x + 1 \leq 2 \Rightarrow 0 \leq (x+1)^2 \leq 2$

$\Rightarrow |x+1| \leq \sqrt{2} \Rightarrow x \in [-1 - \sqrt{2}, \sqrt{2} - 1]$

(ii)  $f(x) = \frac{\sqrt{1-\sin x}}{\log_3(1-4x^2)} + \cot^{-1}(1-\{x\})$  is real and finite if

$1 - 4x^2 > 0$  and  $1 - 4x^2 \neq 1$

$\Rightarrow (2x-1)(2x+1) < 0$  and  $x \neq 0$

$\Rightarrow x \in \left(-\frac{1}{2}, 0\right) \cup \left(0, \frac{1}{2}\right)$

(iii)  $f(x) = \sqrt{3-x} + \cos^{-1}\left(\frac{3-2x}{5}\right) + \log_6(2|x|-3) + \sin^{-1}$

$(\log_2 x)$  is defined

iff  $\begin{cases} 3-x \geq 0 & \& -1 \leq \frac{3-2x}{5} \leq 5 \\ 2|x|-3 > 0 & \& -1 \leq \log_2 x \leq 1 \end{cases}$

$\Rightarrow \begin{cases} x \in (-\infty, 3] & \& x \in [-11, 4] \\ x \in \left(-\infty, -\frac{3}{2}\right) \cup \left(\frac{3}{2}, \infty\right) & \& x \in \left[\frac{1}{2}, 2\right] \end{cases}$

Taking intersection of domain sets

$\Rightarrow x \in \left(\frac{3}{2}, 2\right]$

(iv)  $y = \sqrt{\sin(\cos x)}$  to be defined  $\cos x \geq 0$

$\Rightarrow x \in \left[2n\pi - \frac{\pi}{2}, 2n\pi + \frac{\pi}{2}\right]; n \in \mathbb{Z} \quad \dots(i)$

$y = \ln(-2\cos^2 x + 3\cos x - 1)$  to be real and finite  $2\cos^2 x - 3\cos x + 1 < 0$

$\Rightarrow (2\cos x - 1)(\cos x - 1) < 0 \Rightarrow \cos x \in \left(\frac{1}{2}, 1\right)$

$\Rightarrow x \in \left(2n\pi - \frac{\pi}{3}, 2n\pi + \frac{\pi}{3}\right) \sim \{2n\pi\}; n \in \mathbb{Z} \quad \dots(ii)$

Similarly  $y = e^{\cos^{-1}\left(\frac{2\sin x + 1}{2\sqrt{2\sin x}}\right)}$  to be defined

$-1 \leq \frac{2\sin x + 1}{2\sqrt{2\sin x}} \leq 1$  and  $\sin x > 0$



4.98 ➤ Trigonometry

$$\Rightarrow 2 \sin x + 1 \geq -2\sqrt{2\sin x} \quad \dots\text{(iii)}$$

$$\text{And } 2\sin x + 1 \leq 2\sqrt{2\sin x} \quad \dots\text{(iv)}$$

$$\text{And } \sin x > 0 \quad \dots\text{(v)}$$

From (iv) and (v) as (iii) holds good always, we get,  
 $4\sin^2 x + 1 + 4\sin x \leq 8 \sin x$  and  $\sin x > 0$

$$\Rightarrow 4\sin^2 x - 4 \sin x + 1 \leq 0 \text{ and } \sin x > 0$$

$$\Rightarrow (2\sin x - 1)^2 \leq 0 \text{ and } \sin x > 0$$

$$\Rightarrow 2\sin x - 1 = 0 \text{ and } \sin x > 0$$

$$\Rightarrow \sin x = 1/2$$

$$\Rightarrow x = 2n\pi + \frac{\pi}{6} \text{ or } (2n-1)\pi - \frac{\pi}{6}; n \in \mathbb{Z}$$

But at  $x = (2n-1)\pi - \pi/6$   $\cos x < 0$ . Therefore rejected as it does not satisfy the out come of equation (i) and (ii)

Thus  $x = 2n\pi + \frac{\pi}{6}; n \in \mathbb{Z}$  is the domain set

$$D_f = \left\{ x : 2n\pi + \frac{\pi}{6}, n \in \mathbb{Z} \right\}$$

6. (a)  $f(x) = \cos^{-1}\left(\frac{3}{3+\sin x}\right)$  is defined iff  $-1 \leq \frac{3}{3+\sin x} \leq 1$

and  $3 + \sin x \neq 0$ .

As  $3 + \sin x > 0$  therefore  $\frac{3}{3+\sin x} \leq 1$

$$\Rightarrow \sin x \geq 0$$

$$\Rightarrow x \in [2n\pi, (2n+1)\pi]; n \in \mathbb{I}$$

$$\Rightarrow D_f : \bigcup_{n \in \mathbb{Z}} [2n\pi, (2n+1)\pi]$$

(b)  $f(x) = \sin^{-1}(\log_2(x^2 + 3x + 4))$  to be defined  $-1 \leq \log_2(x^2 + 3x + 4) \leq 1$

$$\Rightarrow \frac{1}{2} \leq x^2 + 3x + 4 \leq 2 \Rightarrow 1 \leq 2x^2 + 6x + 8 \leq 4$$

$$\Rightarrow \begin{cases} 2x^2 + 6x + 7 \geq 0 & \& x \in \mathbb{R} & \& \\ x^2 + 3x + 2 \leq 0 & \Rightarrow & (x+1)(x+2) \leq 0 \end{cases}$$

$$\Rightarrow x \in \mathbb{R} \cap [-2, -1] \Rightarrow x \in [-2, -1]$$

7. (i)  $f(x) = \cos^{-1}(2x - x^2)$  for domain  $-1 \leq 2x - x^2 \leq 1$

$$\Rightarrow -1 \leq x^2 - 2x \leq 1 \Rightarrow 0 \leq x^2 - 2x + 1 \leq 2$$

$$\Rightarrow |x - 1| \leq \sqrt{2} \Rightarrow x \in [1 - \sqrt{2}, 1 + \sqrt{2}]$$

**For range:**  $\because -1 \leq 2x - x^2 \leq 1$  if  $x \in D_f$

$\Rightarrow \cos^{-1}(-1) \geq f(x) \geq \cos^{-1}(1)$  as  $\cos^{-1}x$  is decreasing function

$\Rightarrow 0 \leq f(x) \leq \pi$ , thus range of  $f(x)$  in  $[0, \pi]$

$$\Rightarrow D_f : [1 - \sqrt{2}, 1 + \sqrt{2}]; R_f : [0, \pi]$$

(ii)  $f(x) = \tan^{-1}(\log_{4/25}(5x^2 - 8x + 4))$

Since  $\tan^{-1}x$  is defined  $\forall x \in \mathbb{R}$ , thus  $f(x)$  is defined if  $5x^2 - 8x + 4 > 0$

Which is true  $\forall x \in \mathbb{R}$ , as the quadratic polynomial has  $a > 0$  and  $D < 0$ .

$\Rightarrow D_f$  is  $\mathbb{R}$  for range

**For range:**

$$\Rightarrow 5x^2 - 8x + 4 = 5\left(x - \frac{4}{5}\right)^2 + \frac{4}{25}$$

$$\Rightarrow \frac{4}{25} \leq 5x^2 - 8x + 4 < \infty; \text{ taking log to the base } \frac{4}{25}$$

$$\Rightarrow 1 \geq \log_{4/25}(5x^2 - 8x + 4) > -\infty, \text{ operating } \tan^{-1}x \text{ we get}$$

$$\frac{\pi}{4} \geq f(x) > -\frac{\pi}{2}$$

$$\Rightarrow \text{Range of } f(x) \text{ is } \left(-\frac{\pi}{2}, \frac{\pi}{4}\right]$$

$$\Rightarrow D_f : \mathbb{R} \text{ and } R_f : \left(-\frac{\pi}{2}, \frac{\pi}{4}\right]$$

8. (i)  $y = \cos^{-1}[x]$  for domain  $-1 \leq [x] \leq 1$

$$\Rightarrow x \in [-1, 2)$$

**For range:** Since  $[x] = -1, 0, 1$

$$\Rightarrow y = \cos^{-1}[x] \in \left\{ \pi, \frac{\pi}{2}, 0 \right\}$$

$$\Rightarrow D_f : [-1, 2]; R_f : \left\{ 0, \frac{\pi}{2}, \pi \right\}$$

(ii)  $y = \sin^{-1}(e^x)$  to be defined  $-1 \leq e^x \leq 1$

$$\Rightarrow 0 < e^x \leq 1 \Rightarrow e^{-\infty} < e^x \leq e^0$$

$$\Rightarrow x \in (-\infty, 0]$$

**For range:** If  $x \in (-\infty, 0]$

$$\Rightarrow 0 < e^x \leq 1 \Rightarrow \sin^{-1}0 < \sin^{-1}(e^x) \leq \sin^{-1}(1)$$

$$\Rightarrow 0 < f(x) \leq \frac{\pi}{2} \Rightarrow y \in \left(0, \frac{\pi}{2}\right]$$

$$\Rightarrow D_f : (-\infty, 0] \text{ and } R_f : \left(0, \frac{\pi}{2}\right]$$

(iii)  $y = \cos^{-1}\{x\}$

Clearly defined  $\forall x \in \mathbb{R}$  as  $\{x\} \in [0, 1)$  thus function remains defined.

**For range:**  $0 \leq \{x\} < 1$

$$\Rightarrow \cos^{-1}0 \geq \cos^{-1}\{x\} > \cos^{-1}(1)$$

$$\Rightarrow \frac{\pi}{2} \geq y > 0$$

$$\Rightarrow y \in \left(0, \frac{\pi}{2}\right] \Rightarrow D_f : \mathbb{R}; R_f : \left(0, \frac{\pi}{2}\right]$$

(iv)  $y = \sin^{-1}\{x\}$ . Domain same as  $y = \cos^{-1}\{x\}$

$$\Rightarrow D_f : \mathbb{R}$$

**For range:**  $y = \sin^{-1}\{x\}$

$$\Rightarrow 0 \leq \{x\} < 1$$

$$\Rightarrow \sin^{-1}0 \leq \sin^{-1}\{x\} < \sin^{-1}(1)$$

$$\Rightarrow 0 \leq y < \pi/2 \Rightarrow y \in \left(0, \frac{\pi}{2}\right)$$

$$\Rightarrow D_f : \mathbb{R} \text{ and } R_f : y \in \left(0, \frac{\pi}{2}\right)$$

(v)  $y = \cot^{-1}(\text{sgn } x)$

Clearly domain is  $\mathbb{R}$  as both  $\cot^{-1}x$  and  $\text{sgn}(x)$  functions are defined for all real number.

$$\because \text{sgn}(x) \in \{-1, 0, 1\}$$

$$\Rightarrow \cot^{-1}(\text{sgn } x) \in \{\cot^{-1}(-1), \cot^{-1}(0), \cot^{-1}(1)\}$$

$$\Rightarrow y \in \left\{ \frac{3\pi}{4}, \frac{\pi}{2}, \frac{\pi}{4} \right\} \Rightarrow D_f : \mathbb{R} \text{ and } R_f : \left\{ \frac{\pi}{4}, \frac{\pi}{2}, \frac{3\pi}{4} \right\}$$

9. (i)  $\because \sin^{-1}\frac{36}{85} = \alpha, \cos^{-1}\frac{4}{5} = \beta$  and  $\tan^{-1}\left(\frac{8}{15}\right) = \gamma$

$$\Rightarrow \cot \alpha = \cot\left(\sin^{-1}\frac{36}{85}\right) = \frac{77}{36}$$

And  $\cot \beta = \cot\left(\cot^{-1}\frac{4}{5}\right) = \frac{4}{3}$ . Similarly  $\cot \gamma = 15/8$

Therefore  $\Sigma \cot \alpha = \cot \alpha + \cot \beta + \cot \gamma$   
 $= \frac{77}{36} + \frac{4}{3} + \frac{15}{8} = \frac{385}{72} = \frac{77}{36} \times \frac{4}{3} \times \frac{15}{8} = \cot \alpha \cot \beta \cot \gamma$   
 $= \prod \cot \alpha \dots (i)$

(ii) Further dividing by  $\cot \alpha \cdot \cot \beta \cdot \cot \gamma$  both side of (i) we get,  $\tan \beta \tan \gamma + \tan \alpha \tan \gamma + \tan \alpha \tan \beta = 1$   
 $\Rightarrow \Sigma \tan \alpha \tan \beta = 1$  hence proved.

10.  $\cot^{-1}\left(\frac{n}{\pi}\right) > \frac{\pi}{6}; n \in \mathbb{N}$   
 $\Rightarrow \frac{\pi}{6} < \cos^{-1}\left(\frac{n}{\pi}\right) \leq \pi$  applying cosine:  
 $\Rightarrow \cos \frac{\pi}{6} > \frac{n}{\pi} \geq -1 \Rightarrow \frac{\sqrt{3}}{2} > \frac{n}{\pi} \geq -1$   
 $\Rightarrow n < \frac{\pi\sqrt{3}}{2} \approx \frac{19}{7}$  (approx)  
 $\Rightarrow n = 1, 2$  as  $n \in \mathbb{N}$   
 Thus maximum value of  $n = 2$ .

11.  $\cos^{-1}\left(\lim_{n \rightarrow \infty} \left(\frac{1}{\sum_{k=0}^n \frac{1}{2^k}}\right)\right) = \cos^{-1}\left(\frac{1}{\sum_{k=0}^{\infty} \left(\frac{1}{2^k}\right)}\right) = \cos^{-1}\left(\frac{1}{2}\right) = \frac{\pi}{3}$

12. (a)  $2(\sin^{-1}x)^2 - (\sin^{-1}x) - 6 = 0$   
 $\Rightarrow (2\sin^{-1}x + 3)(\sin^{-1}x - 2) = 0$   
 $\Rightarrow \sin^{-1}x = -\frac{3}{2}$  or  $2$   
 $\Rightarrow \sin^{-1}x = -\frac{3}{2}$  as  $\sin^{-1}x \in \left[-\frac{\pi}{2}, \frac{\pi}{2}\right]$   
 So  $\sin^{-1}x = 2$  is not possible  
 $\Rightarrow x = -\sin\left(\frac{3}{2}\right)$   
 (b)  $\because 0 \leq x \leq 1 \Rightarrow 1 \leq 1+x \leq 2$   
 $\Rightarrow \frac{1}{2} \leq \frac{1}{1+x} \leq 1 \Rightarrow 1 \leq \frac{2}{1+x} \leq 2$   
 $\Rightarrow 0 \leq \frac{2}{1+x} - 1 \leq 1 \Rightarrow 0 \leq \frac{1-x}{1+x} \leq 1$   
 $\Rightarrow \tan^{-1}(0) \leq \tan^{-1}\left(\frac{1-x}{1+x}\right) \leq \tan^{-1}(1)$   
 $\Rightarrow 0 \leq f(x) \leq \frac{\pi}{4} \Rightarrow f_{\min} = 0$  and  $f_{\max} = \frac{\pi}{4}$   
 $\Rightarrow$  Range:  $\left[0, \frac{\pi}{4}\right]$

13. Let  $\frac{1}{2}\cos^{-1}\left(\frac{a}{b}\right) = \theta; \cos 2\theta = a/b$   
 L.H.S. =  $\tan\left(\frac{\pi}{4} + \theta\right) + \tan\left(\frac{\pi}{4} - \theta\right)$   
 $= \frac{1 + \tan \theta}{1 - \tan \theta} + \frac{1 - \tan \theta}{1 + \tan \theta} = 2\left(\frac{1 + \tan^2 \theta}{1 - \tan^2 \theta}\right)$   
 $= \frac{2}{\cos 2\theta} = \frac{2}{a/b} = \frac{2b}{a} = \text{R.H.S.}$

14. Let  $(\cos^{-1}x) = y$  the inequality becomes  $y^2 - 5y + 6 > 0$   
 $\Rightarrow (y - 2)(y - 3) > 0$   
 $\Rightarrow y < 2$  or  $y > 3 \Rightarrow \cot^{-1}x < 2$  or  $\cot^{-1}x > 3$   
 $\Rightarrow 0 < \cot^{-1}x < 2$  or  $\pi > \cot^{-1}x > 3$

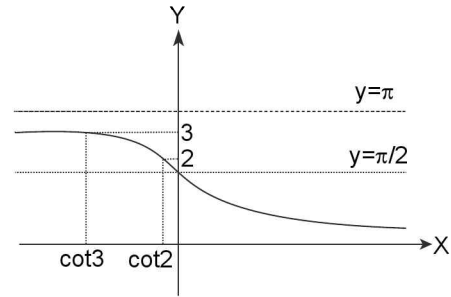

$\because \cot^{-1}x$  is a decreasing function  
 $\Rightarrow \cot 0 > x > \cot 2$  or  $\cot \pi < x < \cot 3$   
 $\Rightarrow x \in (\cot 2, \infty) \cup (-\infty, \cot 3)$   
 $\Rightarrow x \in (-\infty, \cot 3) \cup (\cot 2, \infty)$ .

15.  $\sin^{-1}(x^2 - 2x + 2)$  is defined iff  $x^2 - 2x + 2 \in [-1, 1]$   
 i.e.,  $(x - 1)^2 + 1 \in [-1, 1]$   
 $\Rightarrow x = 1$ , therefore the equation  $ax^2 + \sin^{-1}(x^2 - 2x + 2) + \cos^{-1}(x^2 - 2x + 2) = 0$  has real solution only  $x = 1$   
 if  $a + \sin^{-1}(1) + \cos^{-1}(1) = 0$  i.e.,  $a = -\pi/2$
16. (i)  $f(x) = \sec^{-1}(x^2 + 3x + 1)$  to be defined  $x^2 + 3x + 1 \notin (-1, 1)$ , so let us take  $-1 \leq x^2 + 3x + 1 < 1$   
 $\Rightarrow x^2 + 3x + 2 > 0$  and  $x^2 + 3x < 0$   
 $\Rightarrow (x + 1)(x + 2) > 0$  and  $x(x + 3) < 0$   
 $\Rightarrow x \in (-\infty, -2) \cup (-1, \infty)$  and  $x \in (-3, 0)$   
 Taking  $\cap$  of both sets, we get,  $x \in (-3, -2) \cup (-1, 0)$   
 Therefore  $f(x)$  to be defined  $x \notin (-3, -2) \cup (-1, 0)$   
 $\Rightarrow x \in (-\infty, -3] \cup [-2, -1] \cup [0, \infty)$   
 $\Rightarrow D_f: (-\infty, -3] \cup [-2, -1] \cup [0, \infty)$
- (ii)  $y = \cos^{-1}\left(\frac{x^2}{x^2 + 1}\right)$  is defined  $\forall x \in \mathbb{R}$  as  $0 \leq \frac{x^2}{x^2 + 1} < 1$   
 $\forall x \in \mathbb{R}$  and thus  $\cos^{-1}\left(\frac{x^2}{x^2 + 1}\right)$  takes real and finite values  $\in \left(0, \frac{\pi}{2}\right]$   
 $\Rightarrow D_f: \mathbb{R}$
- (iii)  $y = \tan^{-1}\left(\sqrt{x^2 - 1}\right)$  takes real and finite values if  $\sqrt{x^2 - 1}$  is real and finite thus  $x^2 - 1 \geq 0$   
 $\Rightarrow x \in (-\infty, -1] \cup [1, \infty)$   
 $\Rightarrow D_f: (-\infty, -1] \cup [1, \infty)$

18.  $\tan^2(\sin^{-1}x) > 1$   
 $\Rightarrow \begin{cases} \tan(\sin^{-1}x) < -1 \\ \text{or} \\ \tan(\sin^{-1}x) > 1 \end{cases}$   
 Operating  $\tan^{-1}x$  both side as  $\tan^{-1}(\tan x) = x \forall x \in \left(-\frac{\pi}{2}, \frac{\pi}{2}\right)$

Hence we get  $\begin{cases} -\frac{\pi}{2} < \sin^{-1} x < -\frac{\pi}{4} \\ \text{or} \\ \frac{\pi}{4} < \sin^{-1} x < \frac{\pi}{2} \end{cases}$

$\Rightarrow \begin{cases} -1 < x < -\frac{1}{\sqrt{2}} \\ \text{or} \\ \frac{1}{\sqrt{2}} < x < 1 \end{cases}$

$\Rightarrow x \in \left(-1, -\frac{1}{\sqrt{2}}\right) \cup \left(\frac{1}{\sqrt{2}}, 1\right)$

19. (i)  $\tan^{-1}x > \cot^{-1}x \Rightarrow 2\tan^{-1}x > \frac{\pi}{2}$   
 $\Rightarrow \tan^{-1}x > \frac{\pi}{4} \Rightarrow x \in (1, \infty)$

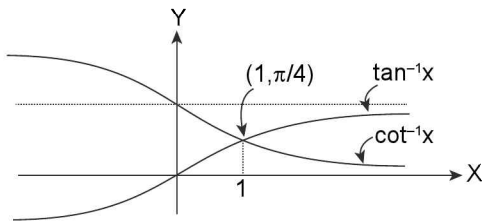

(ii) Therefore,  $\tan^{-1}x < \cot^{-1}x$   
 $\Rightarrow x \in (-\infty, 1)$

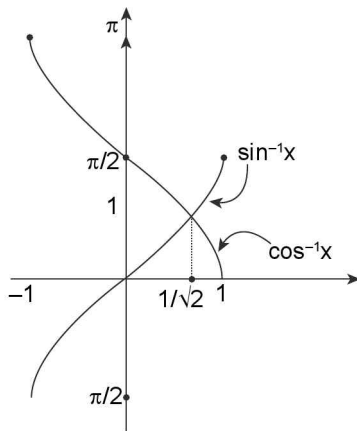

(iii) and (iv)  $\sin^{-1}x > \cos^{-1}x$   
 $\Rightarrow 2\sin^{-1}x > \frac{\pi}{2} \Rightarrow \sin^{-1}x > \frac{\pi}{4}$   
 $\Rightarrow \frac{\pi}{4} < \sin^{-1}x \leq \frac{\pi}{2} \Rightarrow \frac{1}{\sqrt{2}} < x \leq 1$   
 $\Rightarrow x \in \left(\frac{1}{\sqrt{2}}, 1\right]$

Thus for  $\sin^{-1}x < \cos^{-1}x$

$\Rightarrow x \in \left[-1, \frac{1}{\sqrt{2}}\right)$

Result can be verified from the graph.

20.  $f(x) = \cot^{-1}(x^2 + 4x + \alpha^2 - \alpha)$  is a function  $f: \mathbb{R} \rightarrow \left(0, \frac{\pi}{2}\right]$   
 to be defined we must have  $0 < \cot^{-1}(x^2 + 4x + \alpha^2 - \alpha) \leq \pi/2$   
 $\Rightarrow 0 \leq x^2 + 4x + \alpha^2 - \alpha < \infty \forall x \in \mathbb{R}$   
 $\Rightarrow D \leq 0$   
 $\Rightarrow 16 - 4(\alpha^2 - \alpha) \leq 0 \Rightarrow 4\alpha^2 - 4\alpha - 16 \geq 0$   
 $\Rightarrow \alpha^2 - \alpha - 4 \geq 0$   
 $\Rightarrow \alpha \in \left(-\infty, \frac{1-\sqrt{17}}{2}\right] \cup \left[\frac{1+\sqrt{17}}{2}, \infty\right)$  and  $f$  to be on to  
 $\alpha = \frac{1 \pm \sqrt{17}}{2}$

**TEXTUAL EXERCISE-1 (OBJECTIVE)**

- (b)  $\sin^{-1}\frac{\sqrt{3}}{2} + \sin^{-1}\frac{1}{\sqrt{2}} = \frac{\pi}{3} + \frac{\pi}{4} = \frac{7\pi}{12} = 105^\circ$
- (d)  $\sin\left(\frac{\pi}{3} - \sin^{-1}\left(-\frac{1}{2}\right)\right) = \sin\left(\frac{\pi}{3} - \left(-\frac{\pi}{6}\right)\right) = \sin\left(\frac{\pi}{2}\right) = 1$
- (a)  $\cos^{-1}\left(\cos\frac{2\pi}{3}\right) + \sin^{-1}\left(\sin\frac{2\pi}{3}\right)$   
 $= \cos^{-1}\left(-\frac{1}{2}\right) + \sin^{-1}\left(\frac{\sqrt{3}}{2}\right) = \frac{\pi}{3} + \frac{\pi}{3} = \frac{2\pi}{3}$
- (d)  $\operatorname{cosec}^{-1}(\cos x)$  to be defined  $|\cos x| \geq 1$ , but we know that  $|\cos x| \leq 1$  therefore we have  $|\cos x| = 1$   
 $\Rightarrow \cos x = \pm 1 \Rightarrow x = n\pi$
- (a)  $\sum_{i=1}^n \cos^{-1} \alpha_i = 0 \because \cos^{-1} \alpha_k \in [0, \pi]$   
 $\Rightarrow \cos^{-1}(\alpha_i) = 0 \forall i = 1, 2, \dots, n$   
 $\Rightarrow \alpha_i = 1 \forall i = 1, 2, \dots, n$   
 $\Rightarrow \sum_{i=1}^n \alpha_i = \sum_{i=1}^n 1 = n$
- (a, b)  $\sin^{-1}x + \sin^{-1}y + \sin^{-1}z = \frac{3\pi}{2}$   
 Since  $\sin^{-1} \in \left[-\frac{\pi}{2}, \frac{\pi}{2}\right]$ , thus its maximum value is  $\pi/2$  consequently above equation holds good iff  $\sin^{-1}x = \sin^{-1}y = \sin^{-1}z = \pi/2$   
 $\Rightarrow x = y = z = 1$   
 $x^{100} + y^{100} + z^{100} - \frac{9}{x^{101} + y^{101} + z^{101}} = 3 - 3 = 0$   
 $\therefore$  Option (a) is correct.  
 $x^{22} + y^{42} + z^{62} - x^{220} + y^{420} - z^{620} = 3 - 3 = 0$   
 $\therefore$  Option (b) is correct.  
 Option (c) and (d) are clearly not true.
- (b)  $2\sqrt{2} - 1 \approx 1.828^\circ \in \left(\frac{\pi}{2}, \pi\right)$   
 $\therefore \tan^{-1}(2\sqrt{2} - 1) < 0$  i.e.,  $A < 0$ , where as  
 $B = 3\sin^{-1}\frac{1}{3} + \sin^{-1}\frac{3}{5} > 0$

$\therefore \forall x \in (0, 1] \sin^{-1}x \in \left(0, \frac{\pi}{2}\right]$ , i.e.,  $\sin^{-1}x$  takes positive values

$\Rightarrow$  Consequently  $B > A$ .

8. (d)  $f(x) = \cos^{-1}x + \cot^{-1}x + \operatorname{cosec}^{-1}x$  domain of  $f(x)$  is  $[-1, 1] \cap (-\infty, \infty) \cap \mathbb{R} \sim (-1, 1)$

Clearly  $D_f = \{-1, 1\}$ .

9. (a)  $f(x) = \cos^{-1}\left(\frac{5}{5+\sin x}\right)$  to be defined  $-1 \leq \frac{5}{5+\sin x} \leq 1$

$\Rightarrow \frac{5}{5+\sin x}$  is always positive

$\Rightarrow 5 \leq 5 + \sin x$

$\Rightarrow \sin x \geq 0 \Rightarrow x \in \bigcup_{n \in \mathbb{Z}} [2n\pi, (2n+1)\pi]$

10. (b)  $f(x) = \sqrt{\sin^{-1}(2x) + \frac{\pi}{6}}$  to be defined  $\sin^{-1}(2x) + \frac{\pi}{6} \geq 0$

and  $-1 \leq 2x \leq 1$

$\Rightarrow -\frac{\pi}{6} \leq \sin^{-1}2x \leq \frac{\pi}{2}$  and  $-\frac{1}{2} \leq x \leq \frac{1}{2}$

$\Rightarrow -\frac{1}{2} \leq 2x \leq 1$  and  $-\frac{1}{2} \leq x \leq \frac{1}{2}$

$\Rightarrow x \in \left[-\frac{1}{4}, \frac{1}{2}\right] \cap \left[-\frac{1}{2}, \frac{1}{2}\right]$

$\Rightarrow x \in \left[-\frac{1}{4}, \frac{1}{2}\right]$

11. (c)  $f(x) = \sin^{-1}x + \tan^{-1}x + \sec^{-1}x$ , clearly domain of  $f(x)$  is  $\{-1, 1\}$ , thus range of  $f(x) = \{f(-1), f(1)\}$

$= \left\{-\frac{\pi}{2} - \frac{\pi}{4} + \pi, \frac{\pi}{2} + \frac{\pi}{4} + 0\right\} = \left\{\frac{\pi}{4}, \frac{3\pi}{4}\right\}$

12. (c)  $f(x) = \cos^{-1}[1 + \sin^2x]$  for domain of  $f(x)$ :  $[1 + \sin^2x] \leq 1$

$\Rightarrow [\sin^2x] \leq 0 \Rightarrow [\sin^2x] = 0$

$\Rightarrow 0 \leq \sin^2x < 1$

$\Rightarrow -1 < \sin x < 1$ , with in domain  $[1 + \sin^2x] = 1$

$\Rightarrow f(x) = \cos^{-1}(1) \forall x \in D_f = 0$

13. (c)  $\sec^{-1}(\sec(-30^\circ)) = \sec^{-1}(\sec 30^\circ) = \sec^{-1}\left(\frac{2}{\sqrt{3}}\right) = \frac{\pi}{6}$

14. (a) Let  $\sin^{-1}(0.8) = \theta$

$\Rightarrow \sin \theta = \frac{4}{5}$  and  $\theta \in \left[-\frac{\pi}{2}, \frac{\pi}{2}\right]$

$\sin(2 \sin^{-1}(0.8)) = \sin 2\theta = 2\sin\theta \cos\theta$

$= 2\left(\frac{4}{5}\right)\left(\frac{3}{5}\right) = \frac{24}{25} = 0.96$

15. (d)  $\tan^{-1}\left(\frac{\sqrt{1+x^2}-1}{x}\right) = 4^\circ$

$\Rightarrow \frac{\sqrt{1+x^2}-1}{x} = \tan(4^\circ)$

Let  $x = \tan\theta \Rightarrow \frac{\sec\theta-1}{\tan\theta} = \tan 4^\circ$

$$\Rightarrow \frac{2\sin^2\frac{\theta}{2}}{2\sin\frac{\theta}{2}\cos\frac{\theta}{2}} = \tan 4^\circ \Rightarrow \tan\left(\frac{\theta}{2}\right) = \tan 4^\circ$$

$$\Rightarrow \theta = 8^\circ \Rightarrow x = \tan 8^\circ$$

16. (a, c)  $\cos^{-1}x = \tan^{-1}x = \theta$  and  $\theta \in \left[0, \frac{\pi}{2}\right)$

$\Rightarrow x = \cos\theta = \tan\theta$

$\Rightarrow \cos^2\theta = \sin\theta \Rightarrow \sin^2\theta + \sin\theta - 1 = 0$

$\Rightarrow \sin\theta = \frac{-1 \pm \sqrt{5}}{2}$ , but  $\sin\theta > 0$

$\Rightarrow \sin\theta = \frac{\sqrt{5}-1}{2} = \sin(\cos^{-1}x)$

$\Rightarrow x^2 = \cos^2\theta = 1 - \sin^2\theta$

$$= 1 - \left(\frac{5+1-2\sqrt{5}}{4}\right) = \frac{4-6+2\sqrt{5}}{4} = \left(\frac{\sqrt{5}-1}{2}\right)$$

17. (b)  $\frac{1}{2}\sin^{-1}\left(\frac{3\sin 2\theta}{5+4\cos 2\theta}\right) = \frac{\pi}{4}$

$\Rightarrow \sin^{-1}\left(\frac{3\sin 2\theta}{5+4\cos 2\theta}\right) = \frac{\pi}{2}$

$\Rightarrow 3\sin\theta = 5 + 4\cos 2\theta$

$\Rightarrow \frac{3(2\tan\theta)}{1+\tan^2\theta} = 5 + 4\left(\frac{1-\tan^2\theta}{1+\tan^2\theta}\right)$

$\Rightarrow 6\tan\theta = 5 + 5\tan^2\theta + 4 - 4\tan^2\theta$

$\Rightarrow \tan^2\theta - 6\tan\theta + 9 = 0$

$\Rightarrow (\tan^2\theta - 3)^2 = 0$

$\Rightarrow \tan\theta = 3$

18. (c)  $\sin^{-1}x + \cos^{-1}y + \sin^{-1}z = 2\pi$

Equality possible iff  $\sin^{-1}x = \sin^{-1}z = \pi/2$  and  $\cos^{-1}y = \pi$

$\Rightarrow x = z = 1$  and  $y = -1$

$\Rightarrow$  No of order triplets  $(x, y, z)$  is one i.e.,  $(1, 1, -1)$

19. (b)  $2(\sin^{-1})^2 - 5(\sin^{-1}x) + 2 = 0$

$\Rightarrow (2\sin^{-1}x - 1)(\sin^{-1}x - 2) = 0$

$\Rightarrow \sin^{-1}x = 1/2 \quad \therefore \sin^{-1}x \in \left[-\frac{\pi}{2}, \frac{\pi}{2}\right]$

$\Rightarrow$  then  $\sin^{-1}x \neq 2$

$\Rightarrow x = \sin 1/2$  is only solution

20. (c, d)  $x^2 - x - 2 > 0$

$\Rightarrow (x-2)(x+1) > 0$  if  $\alpha$  satisfied it  $\alpha \in (-\infty, -1) \cup (2, \infty)$

$\Rightarrow$  Clearly,  $\sin^{-1}\alpha, \cos^{-1}\alpha$  does not exist but  $\sec^{-1}\alpha, \operatorname{cosec}^{-1}\alpha$  exist

21. (b, c, d)  $\sin^{-1}x > \cos^{-1}x$

$\Rightarrow \sin^{-1}x > \pi/2 - \sin^{-1}x \Rightarrow 2\sin^{-1}x > \pi/2$

$\Rightarrow \frac{\pi}{2} \geq \sin^{-1}x > \frac{\pi}{4} \Rightarrow \sin\frac{\pi}{4} < \sin(\sin^{-1}x) \leq \sin\frac{\pi}{2}$

$\Rightarrow \frac{1}{\sqrt{2}} < x \leq 1 \Rightarrow x \in \left(\frac{1}{\sqrt{2}}, 1\right]$

Graphically:

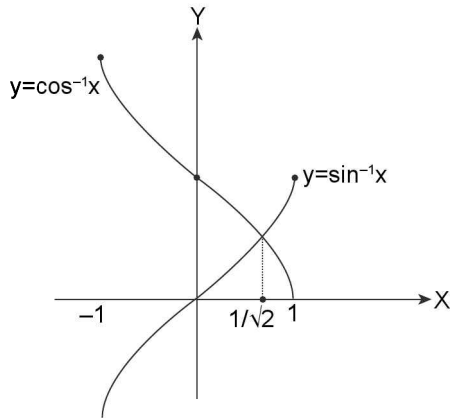

Clearly,  $\forall x \in \left(\frac{1}{\sqrt{2}}, 1\right]$ ,  $\sin^{-1}x > \cos^{-1}x$  holds.

**TEXTUAL EXERCISE-2 (SUBJECTIVE)**

1. (a)  $\sin^{-1}\left[\sin\frac{\pi}{3}\right] = \frac{\pi}{3}$   
 $\left[\because \sin^{-1}(\sin x) = x \text{ for } x \in \left[-\frac{\pi}{2}, \frac{\pi}{2}\right]\right]$
- (b)  $\cos^{-1}\left(\cos\frac{\pi}{6}\right) = \frac{\pi}{6}$   $[\because \cos^{-1}(\cos x) = x \text{ for } x \in [0, \pi]]$
- (c)  $\tan^{-1}\left(\tan\frac{2\pi}{3}\right) = \left(\tan^{-1}\left(\tan\left(\pi - \frac{\pi}{3}\right)\right)\right)$   
 $= \tan^{-1}\left(\tan\left(-\frac{\pi}{3}\right)\right) = \frac{-\pi}{3}$ . As  $\tan^{-1}(\tan x) = x$  for  
 $x \in \left[-\frac{\pi}{2}, \frac{\pi}{2}\right]$
- (d)  $\sin\left[\sin^{-1}\frac{\pi}{3}\right] = \text{not defined}$   
 $[\because \sin(\sin^{-1}x)$  is defined for  $x \in [-1, 1]]$
- (e)  $\cos\left(\cos^{-1}\frac{\pi}{6}\right) = \frac{\pi}{6}$   $[\because \cos(\cos^{-1}x) = x \text{ for } x \in [-1, 1]]$
- (f)  $\tan\left(\tan^{-1}\frac{2\pi}{3}\right) = \frac{2\pi}{3}$   $[\because \tan(\tan^{-1}x) = x \text{ for } x \in (-\infty, \infty)]$
- (g)  $\sin^{-1}(\sin 10) = 3\pi - 10$   
 $(\because \sin^{-1}(\sin x) = x$  only for  $x \in \left[-\frac{\pi}{2}, \frac{\pi}{2}\right])$
- (h)  $\sin(\sin^{-1}10) = \text{not defined}$   
 $[\because \sin(\sin^{-1}x)$  is defined for  $x \in [-1, 1]]$
- (i)  $\cos(\cos^{-1}5) = \text{not defined}$   
 $[\because \cos(\cos^{-1}x) = x$  only for  $x \in [-1, 1]]$
- (j)  $\cos^{-1}(\cos 5) = 2\pi - 5$   
 $\cos^{-1}(\cos 5) = (\cos^{-1} \cos(2\pi - 5))$   
 $\therefore \cos^{-1} \cos x = x$  for  $x \in [0, \pi]$

- (k)  $\tan(\tan^{-1}(-5)) = -5 \tan(\tan^{-1}x) = x$  for  $x \in (-\infty, \infty)$
- (l)  $\tan^{-1}(\tan 5) = -(2\pi - 5) [\tan^{-1}(\tan x) = x$   
for  $x \in \left[-\frac{\pi}{2}, \frac{\pi}{2}\right])$
2. (a)  $\cos^{-1}\left(\cos\frac{7\pi}{6}\right) = \cos^{-1}\left(\cos\left(2\pi - \frac{7\pi}{6}\right)\right)$   
 $= \cos^{-1}\left(\cos\frac{5\pi}{6}\right) = \frac{5\pi}{6}$
- (b)  $\sin\left[\frac{\pi}{2} - \sin^{-1}\left[-\frac{\sqrt{3}}{2}\right]\right] = \cos \sin^{-1}\left(\sin\left[-\frac{\pi}{3}\right]\right)$   
 $= \cos\left(-\frac{\pi}{3}\right) = \frac{1}{2}$
- (c)  $\sin\left[\cos^{-1}\left[\cos\frac{2\pi}{3}\right]\right] = \sin\frac{2\pi}{3} = \frac{\sqrt{3}}{2}$
- (d)  $\sin\left[\tan^{-1}(-\sqrt{3}) + \cos^{-1}\left(-\frac{\sqrt{3}}{2}\right)\right]$   
 $= \sin\left[\tan^{-1}\left(\tan\frac{2\pi}{3}\right) + \cos^{-1}\left(\cos\frac{5\pi}{6}\right)\right]$   
 $\sin\left[\frac{2\pi}{3} + \frac{5\pi}{6}\right] = \sin\left[\frac{9\pi}{6}\right] = \sin\left(-\frac{\pi}{2}\right) = -1$

3.  $\because \sin^{-1}(\sin 8) = 3\pi - 8$   
 $\because \theta \in \left(\frac{5\pi}{2}, 3\pi\right)$  as  $\sin^{-1} \sin x = 3\pi - x$   
 $\Rightarrow \tan^{-1}(\tan 10) = 10 - 3\pi$   
 $\because 10 \in \left(3\pi, \frac{7\pi}{2}\right)$  as  $\tan^{-1} \tan x = x - 3\pi$   
 $\Rightarrow \cos^{-1}(\cos 12) = 4\pi - 12$   
 $\because 12 \in (3\pi, 4\pi)$  as  $\cos^{-1} \cos x = 4\pi - x$  in this interval  
 $\Rightarrow \sec^{-1}(\sec 9) = \cos^{-1}(\cos 9) = -2\pi + 9 \because 9 \in (2\pi, 3\pi)$   
 $\Rightarrow \cot^{-1}(\cot 6) = 6 - \pi \because 6 \in (\pi, 2\pi)$   
 $\Rightarrow \operatorname{cosec}^{-1}(\operatorname{cosec} 7) = \sin^{-1}(\sin 7) = -2\pi + 7$   
 $\therefore 7 \in \left(2\pi, \frac{5\pi}{2}\right)$

**Consequently**

$$y = \sin^{-1}(\sin 8) - \tan^{-1}(\tan 10) + \cos^{-1}(\cos 12) - \sec^{-1}(\sec 9) + \cot^{-1}(\cot 6) - \operatorname{cosec}^{-1}(\operatorname{cosec} 12)$$

$$= (3\pi - 8) - (10 - 3\pi) + 4\pi - 12 - (-2\pi + 9) + 6 - \pi + 2\pi - 7 = 13\pi - 40 \approx a\pi + b$$

Thus  $a = 13$  and  $b = -40$   
 $\Rightarrow a - b = 53$

4. L.H.S.  
 $= \sin^{-1}\left(\sin\frac{33\pi}{7}\right) + \cos^{-1}\left(\cos\frac{46\pi}{7}\right) +$   
 $\tan^{-1}\left(-\tan\frac{13\pi}{8}\right) + \cot^{-1}\left(\cot\left(-\frac{19\pi}{8}\right)\right)$   
 $= \sin^{-1}\left(\sin\left(\frac{2\pi}{7}\right)\right) + \cos^{-1}\left(\cos\left(\frac{4\pi}{7}\right)\right) +$   
 $\tan^{-1}\left(\tan\left(\frac{3\pi}{8}\right)\right) + \cot^{-1}\left(-\cot\frac{3\pi}{8}\right)$

$$\begin{aligned}
 &= \frac{2\pi}{7} + \frac{4\pi}{7} + \frac{3\pi}{8} + \pi - \cot^{-1}\left(\cot\frac{3\pi}{8}\right) \\
 &= \frac{6\pi}{7} + \frac{3\pi}{8} + \pi - \frac{3\pi}{8} = \frac{13\pi}{7}
 \end{aligned}$$

5.  $f(x) = \cos^{-1}x + \cos^{-1}\left(\frac{x}{2} + \frac{1}{2}\sqrt{3-3x^2}\right)$

$$= \cos^{-1}x + \cos^{-1}\left(x \cdot \frac{1}{2} + \frac{\sqrt{3}}{2}\sqrt{1-x^2}\right)$$

Let  $\cos^{-1}x = \theta \in \left(0, \frac{\pi}{3}\right)$  as  $x \in \left(\frac{1}{2}, 1\right)$

$$\begin{aligned}
 f(x) &= \theta + \cos^{-1}\left(\cos\theta \cdot \cos\frac{\pi}{3} + \sin\theta \cdot \sin\frac{\pi}{3}\right) \\
 &= \theta + \cos^{-1}\left(\cos\left(\theta - \frac{\pi}{3}\right)\right) \\
 &= \theta + \frac{\pi}{3} - \theta \text{ as } \theta - \frac{\pi}{3} \in \left(-\frac{\pi}{3}, 0\right) \\
 \Rightarrow f(x) &= \pi/3
 \end{aligned}$$

6. Let  $\tan^{-1}x = \theta \Rightarrow x = \tan\theta$

$$\begin{aligned}
 \Rightarrow \alpha &= 2 \tan^{-1}\left(\frac{1+x}{1-x}\right) = 2 \tan^{-1}\left(\frac{1+\tan\theta}{1-\tan\theta}\right) \\
 &= 2 \tan^{-1}\left(\tan\left(\frac{\pi}{4} + \theta\right)\right) \\
 &= \begin{cases} 2\left(\frac{\pi}{4} + \theta\right); & \text{if } x \in (0,1) \text{ i.e., } \theta \in \left(0, \frac{\pi}{4}\right) \\ 2\left(-\pi + \frac{\pi}{4} + \theta\right); & \text{if } x > 1; \text{ i.e., } \theta \in \left(\frac{\pi}{4}, \frac{\pi}{2}\right) \end{cases} \\
 \Rightarrow \alpha &= \begin{cases} \frac{\pi}{2} + 2\theta; & \text{if } x \in (0,1) \\ -\frac{3\pi}{2} + 2\theta; & \text{if } x > 1 \end{cases} \\
 \text{Similarly } \beta &= \sin^{-1}\left(\frac{1-\tan^2\theta}{1+\tan^2\theta}\right) = \sin^{-1}(\cos 2\theta) \\
 &= \sin^{-1}\left(\sin\left(\frac{\pi}{2} - 2\theta\right)\right) \\
 \beta &= \begin{cases} \frac{\pi}{2} - 2\theta; & \text{if } x \in (0,1) \text{ as } \theta \in \left(0, \frac{\pi}{4}\right), \text{ thus } \frac{\pi}{2} - 2\theta \in \left(0, \frac{\pi}{2}\right) \\ \frac{\pi}{2} - 2\theta; & \text{if } x \in (1, \infty) \text{ i.e., } \theta \in \left(\frac{\pi}{4}, \frac{\pi}{2}\right) \Rightarrow \frac{\pi}{2} - 2\theta \in \left(-\frac{\pi}{2}, 0\right) \end{cases} \\
 \text{Clearly } \alpha + \beta &= \begin{cases} \pi, & \text{if } x \in (0,1) \\ -\pi, & \text{if } x \in (1, \infty) \end{cases} = -\pi
 \end{aligned}$$

7. Let  $\cos^{-1}x = \theta, \sin^{-1}x = \frac{\pi}{2} - \theta$

$$\begin{aligned}
 \Rightarrow x &= \cos\theta = \sin\left(\frac{\pi}{2} - \theta\right) \\
 f(x) &= \sin^{-1}(3x - 4x^3) + \cos^{-1}(4x^3 - 3x) \\
 &= \sin^{-1}\left(\sin 3\left(\frac{\pi}{2} - \theta\right)\right) + \cos^{-1}(\cos 3\theta)
 \end{aligned}$$

$$= \sin^{-1}\left(\sin\left(\frac{3\pi}{2} - 3\theta\right)\right) + \cos^{-1}(\cos 3\theta)$$

Now, since  $x \in \left[-1, -\frac{1}{2}\right]$

$$\Rightarrow \theta = \cos^{-1}x \in \left[\frac{2\pi}{3}, \pi\right] \Rightarrow 3\theta \in [2\pi, 3\pi]$$

$$\Rightarrow \frac{3\pi}{2} - 3\theta \in \left(-\frac{3\pi}{2}, -\frac{\pi}{2}\right)$$

$$\Rightarrow f(x) = -\pi - \left(\frac{3\pi}{2} - 3\theta\right) \pm 2\pi + 3\theta = 6\theta - \frac{9\pi}{2}$$

$$= 6\cos^{-1}x - \frac{9\pi}{2}$$

If  $f(x) = a \cos^{-1}x + b\pi \Rightarrow a = 6$  and  $b = -9/2$

8.  $y = \cos^{-1}\sin x$  and  $y = \sin^{-1}\cos x$  both are periodic function with period  $2\pi$  thus analyzing for  $x \in [0, 2\pi]$

$$y = \cos^{-1}\left(\cos\left(\frac{\pi}{2} - x\right)\right) = \begin{cases} \frac{\pi}{2} - x; & 0 \leq x \leq \frac{\pi}{2} \\ x - \frac{\pi}{2}; & \frac{\pi}{2} \leq x \leq \frac{3\pi}{2} \\ \frac{5\pi}{2} - x; & \frac{3\pi}{2} \leq x \leq 2\pi \end{cases},$$

where as  $y = \sin^{-1}(\cos x) = \sin^{-1}\left(\sin\left(\frac{\pi}{2} - x\right)\right)$

$$= \begin{cases} \frac{\pi}{2} - x; & 0 \leq x \leq \pi \\ x - \frac{3\pi}{2}; & \pi \leq x \leq 2\pi \end{cases}$$

Now the region enclosed is given as shaded in the diagram.

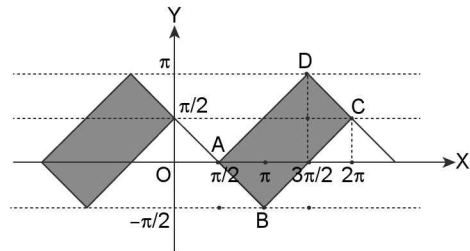

Clearly area enclosed for  $x \in [0, 2\pi] = \text{Area ABCD} = 1/2(2\pi)\pi = \pi^2$

Thus total required area =  $7(\pi^2)$  square units.

Thus  $49A = 7 \times 49 \times \pi^2$  square units =  $343 \pi^2$  square units.

9.  $\therefore \frac{2x^2+4}{1+x^2} = 2 + \frac{2}{1+x^2} \in (2, 4] \forall x \in \mathbb{R}$

$$\Rightarrow \frac{2x^2+4}{1+x^2} \in \left(\frac{\pi}{2}, \frac{3\pi}{2}\right), \text{ therefore}$$

$$\sin^{-1}\left(\sin\left(\frac{2x^2+4}{x^2+1}\right)\right) < \pi - 3$$

4.104 > Trigonometry

$$\Rightarrow \pi - \left( \frac{2x^2 + 4}{x^2 + 1} \right) < \pi - 3 \Rightarrow \frac{2x^2 + 4}{x^2 + 1} > 3$$

$$\Rightarrow 2x^2 + 4 > 3x^2 + 3 \Rightarrow x^2 < 1$$

$$\Rightarrow x \in (-1, 1)$$

10. (i)  $5 \tan^{-1} x + 3 \cot^{-1} x = 2\pi$

$$\Rightarrow 2 \tan^{-1} x + \frac{3\pi}{2} = 2\pi \quad \therefore \tan^{-1} x + \cot^{-1} x = \pi/2$$

$$\Rightarrow 2 \tan^{-1} x = \frac{\pi}{2} \quad \Rightarrow \tan^{-1} x = \frac{\pi}{4}$$

$$\Rightarrow x = 1$$

(ii)  $4 \sin^{-1} x = \pi - \cot^{-1} x$

$$\Rightarrow 3 \sin^{-1} x = \pi - (\sin^{-1} x + \cos^{-1} x)$$

$$\Rightarrow 3 \sin^{-1} x = \frac{\pi}{2} \quad \Rightarrow \sin^{-1} x = \frac{\pi}{6}$$

$$\Rightarrow x = \sin \frac{\pi}{6} = \frac{1}{2} \quad \Rightarrow x = 1/2$$

TEXTUAL EXERCISE-2 (OBJECTIVE)

1. (a, b, d)  $\tan(|\tan^{-1} x|) = \begin{cases} \tan(\tan^{-1} x) & \text{if } x \geq 0 \\ \tan(-\tan^{-1} x) & \text{if } x < 0 \end{cases} = \begin{cases} x, & \text{if } x \geq 0 \\ -x, & \text{if } x < 0 \end{cases}$

$$\Rightarrow \tan|\tan^{-1} x| = |x| \quad \therefore \text{Option (a) is true}$$

$$\cot(|\cot^{-1} x|) = \cot(\cot^{-1} x) = x$$

$$\therefore \cot^{-1} x > 0 \quad \therefore \text{Option (b) is true}$$

$$\tan^{-1}(|\tan x|) = \begin{cases} -x, & \text{if } -\frac{\pi}{2} < x < 0 \\ x, & \text{if } 0 \leq x < \frac{\pi}{2} \end{cases} \text{ and the function is}$$

periodic  $\pi$ .

$$\therefore \text{Option (c) is not true}$$

$$\sin(|\sin^{-1} x|) = \begin{cases} \sin(\sin^{-1} x); & \text{if } 0 \leq x \leq 1 \\ \sin(-\sin^{-1} x); & \text{if } -1 \leq x < 0 \end{cases}$$

$$= \begin{cases} x, & \text{if } 0 \leq x \leq 1 \\ -x, & \text{if } -1 \leq x < 0 \end{cases} = |x| \quad \forall x \in [-1, 1]$$

2. (d)  $\sin^{-1}\left(\sin\left(\frac{2\pi}{3}\right)\right) = \sin^{-1}\left(\sin\left(\frac{\pi}{3}\right)\right) = \frac{\pi}{3}$

3. (b, c, d)  $\cos\left(\frac{1}{2} \cos^{-1}\left(\cos\left(-\frac{14\pi}{5}\right)\right)\right)$   
 $= \cos\left(\frac{1}{2} \cos^{-1}\left(\cos\left(2\frac{4\pi}{5}\right)\right)\right) = \cos\left(\frac{1}{2} \cos^{-1}\left(\cos\frac{4\pi}{5}\right)\right)$

$$\therefore \cos^{-1}(\cos x) = x \quad \forall x \in [0, \pi]$$

$$= \cos\left(\frac{2\pi}{5}\right) = \sin\left(\frac{5\pi}{10} - \frac{4\pi}{10}\right) = \sin\left(\frac{\pi}{10}\right)$$

$$= -\cos\left(\pi - \frac{2\pi}{5}\right) = -\cos\frac{3\pi}{5}$$

4. (d)  $\cos\left[\cos^{-1}\left(\frac{7}{25}\right)\right] = \frac{7}{25}$  as  $\cos(\cos^{-1} x) = x \quad \forall x \in [-1, 1]$

5. (c)  $\sin^{-1}\left(\sin\frac{5\pi}{3}\right) = -2\pi + \frac{5\pi}{3}$

$$\therefore \frac{5\pi}{3} \in \left(\frac{3\pi}{2}, \frac{5\pi}{2}\right) = \frac{\pi}{3}. \text{ Where } \sin^{-1} \sin x = -2\pi + x$$

6 (a, b, c)  $y = \cos^{-1}(\cos 7)$

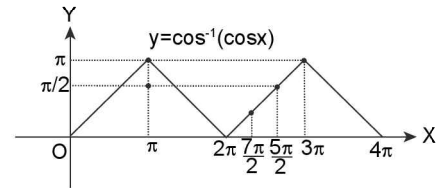

$$\therefore 7 \in (2\pi, 3\pi); \text{ where } \cos^{-1}(\cos x) = -2\pi + x$$

$$\Rightarrow \cos^{-1}(\cos 7) = -2\pi + 7 \approx 7 - 6.28 \approx 0.72 < 1 < \pi/2 \text{ and clearly positive.}$$

7. (c)  $\cos(2 \sin^{-1} x) = \dots$ . Let  $\theta = \sin^{-1} x$ ;  $x = \sin \theta$

$$\Rightarrow \cos 2\theta = 1/9 \quad \Rightarrow 1 - 2 \sin^2 \theta = \frac{1}{9}$$

$$\Rightarrow 2 \sin^2 \theta = \frac{8}{9} \quad \Rightarrow \sin \theta = \pm \frac{2}{3}$$

$$\Rightarrow x = \pm \frac{2}{3}$$

8. (c)  $\cos^{-1}(\cos 8) - \sin^{-1}(\sin 8) = -2\pi + 8 - (3\pi - 8) = 16 - 5\pi$

$$\therefore 8 \in \left(\frac{5\pi}{2}, 3\pi\right)$$

9. (b)  $\therefore \sin^{-1}(\sin x) \in \left[-\frac{\pi}{2}, \frac{\pi}{2}\right]$

$$\cos^{-1}(\cos y) \in [0, \pi]$$

$$\sec^{-1}(\sec x) \in [0, \pi] \sim \{\pi/2\}, \text{ therefore } \sin^{-1}(\sin x) + \cos^{-1}(\cos y) + \sec^{-1}(\sec z) = \frac{5\pi}{2} \text{ possible iff}$$

$$\sin x = 1, \cos y = -1 \text{ and } \sec z = -1$$

$$\Rightarrow \sin x + \cos y + \sec z = -1$$

10. (a)  $\cos^{-1}(\sin(\sin^{-1}(\sin x))) = 0$

$$\Rightarrow \cos^{-1}(\sin x) = 0$$

$$\Rightarrow \sin x = 1 \quad \therefore x \in [0, 2\pi]$$

$$\Rightarrow x = \pi/2 \text{ and therefore } \tan \frac{x}{2} = \tan \frac{\pi}{4} = 1$$

11. (c)  $\sec^{-1}\left(\operatorname{cosec}\left(\cot\left(\cot^{-1}\left(\frac{3\pi}{4}\right)\right)\right)\right) = \sec^{-1}\left(\operatorname{cosec}\left(\frac{3\pi}{4}\right)\right)$

$$= \sec^{-1}\left(\sec\left(\frac{\pi}{2} - \frac{3\pi}{4}\right)\right)$$

$$= \sec^{-1}\left(\sec\left(-\frac{\pi}{4}\right)\right) = \sec^{-1}\left(\sec\left(\frac{\pi}{4}\right)\right) = \frac{\pi}{4}$$

12. (c)  $\left[\sin\left(\tan^{-1}\left(\tan\frac{3\pi}{4}\right)\right)\right] = \left[\sin\left(-\frac{\pi}{4}\right)\right]$

$$= \left[1 - \frac{1}{\sqrt{2}}\right] = \left[\frac{1}{\sqrt{2}}\right] = 0$$

13. (b) Let  $\cos^{-1}\left(\frac{\sqrt{5}}{3}\right) = \theta \in (0, \pi)$   
 $\Rightarrow \cos \theta = \frac{\sqrt{5}}{3}$  ... (i)

$\Rightarrow \tan\left(\frac{1}{2}\cos^{-1}\left(\frac{\sqrt{5}}{3}\right)\right) = \tan \frac{\theta}{2} = t$  (say)

From equation (i), we get,  $\frac{1-t^2}{1+t^2} = \frac{\sqrt{5}}{3}$

Applying componendo and dividendo, we get

$-t^2 = \frac{\sqrt{5}-3}{\sqrt{5}+3}$

$\Rightarrow t^2 = \frac{(3-\sqrt{5})^2}{4} \Rightarrow t = \pm \frac{3-\sqrt{5}}{2}$  but  $\theta \in \left(0, \frac{\pi}{2}\right)$

therefore rejecting -ve sign

$\Rightarrow t = \frac{3-\sqrt{5}}{2}$

14. (b, c)  $\theta = \tan^{-1}\left(\tan \frac{5\pi}{4}\right) = -\pi + \frac{5\pi}{4} = \frac{\pi}{4}$

$\phi = \tan^{-1}\left(-\tan \frac{2\pi}{3}\right) = \tan^{-1}\left(-\tan\left(\pi - \frac{\pi}{3}\right)\right)$

$= \tan^{-1}\left(\tan \frac{\pi}{3}\right) = \frac{\pi}{3}$

Consequently  $\theta < \phi$

$4\theta - 3\phi = \pi - \pi = 0$  &  $\theta + \phi = \frac{\pi}{4} + \frac{\pi}{3} = \frac{7\pi}{12}$

15. (d)  $\because x \in \left[\frac{\pi}{2}, \pi\right]$

$\cos^{-1}(\cos x) = x$

$\sin^{-1}(\sin x) = \pi - x$

$\Rightarrow \sin^{-1}[\cos(\cos^{-1}(\cos x)) + \sin^{-1}(\sin x)]$

$= \sin^{-1}(\cos \pi) = \sin^{-1}(-1) = -\pi/2$

16. (i) (b); (ii) (a)

Let  $x = \cos \theta$  i.e.,  $\cos^{-1}x = \theta \in (0, \pi)$

$f(x) = \theta + \cos^{-1}\left(\cos \theta \cos \frac{\pi}{3} + \sin \frac{\pi}{3} |\sin \theta|\right)$

$= \theta + \cos^{-1}\left(\cos\left(\frac{\pi}{3} - \theta\right)\right) \because \sin \theta > 0$

$= \begin{cases} \theta + \frac{\pi}{3} - \theta = \frac{\pi}{3} & \text{if } x > \frac{1}{2} \Rightarrow \theta \in \left(0, \frac{\pi}{3}\right) \text{ i.e. } \frac{\pi}{3} - \theta \in \left(0, \frac{\pi}{3}\right) \\ \theta + \theta - \frac{\pi}{3} & \text{if } x \in \left[-\frac{1}{2}, \frac{1}{2}\right] \Rightarrow \theta \in \left(\frac{\pi}{3}, \pi\right) \text{ i.e. } \frac{\pi}{3} - \theta \in \left[-\frac{2}{3}, 0\right) \end{cases}$

$\Rightarrow f(x) = \begin{cases} \frac{\pi}{3} & \text{if } x \in \left[\frac{1}{2}, 1\right] \\ 2\cos^{-1}x - \frac{\pi}{3} & \text{if } x \in \left[-\frac{1}{2}, \frac{1}{2}\right] \end{cases}$

$\Rightarrow f(2/3) = \pi/3$  &  $f(1/3) = 2\cos^{-1}\frac{1}{3} - \frac{\pi}{3}$

TEXTUAL EXERCISE-3 (SUBJECTIVE)

1 (a)  $\cos\left(\cos\left(\frac{7\pi}{6}\right)\right) = 2\pi - \frac{7\pi}{6}$  as  $\cos^{-1}(\cos x) = 2\pi - x \forall$

$x \in [\pi, 2\pi] = \frac{5\pi}{6}$

(b)  $\sin\left(\frac{\pi}{2} - \sin^{-1}\left(-\frac{\sqrt{3}}{2}\right)\right) = \cos\left(\sin^{-1}\left(-\frac{\sqrt{3}}{2}\right)\right)$

$= \cos\left(-\frac{\pi}{3}\right) = \cos \frac{\pi}{3} = \frac{1}{2}$

(c)  $\sin\left(\arccos\left(-\frac{1}{2}\right)\right) = \sin\left(\cos^{-1}\left(-\frac{1}{2}\right)\right)$

$= \sin\left(\pi - \cos^{-1}\frac{1}{2}\right) = \sin\left(\pi - \frac{\pi}{3}\right) = \frac{\sqrt{3}}{2}$

(d)  $\sin\left(\tan^{-1}(-\sqrt{3}) + \cos^{-1}\left(-\frac{\sqrt{3}}{2}\right)\right)$

$= \sin\left(-\tan^{-1}(\sqrt{3}) + \pi - \cos^{-1}\frac{\sqrt{3}}{2}\right)$

$= \sin\left(-\frac{\pi}{3} + \pi - \frac{\pi}{6}\right) = \sin\left(\frac{3\pi}{6}\right) = 1$

2 (a)  $\sin\left(\cos^{-1}\frac{3}{5}\right) = \sin\left(\sin^{-1}\sqrt{1 - \frac{9}{25}}\right) = \frac{4}{5}$

(b)  $\cos\left(\tan^{-1}\frac{3}{4}\right) = \cos\left(\cos^{-1}\left(\frac{1}{\sqrt{1+9/16}}\right)\right) = \frac{1}{5/4} = \frac{4}{5}$

(c)  $\sin\left(\frac{\pi}{2} - \sin^{-1}\left(-\frac{1}{2}\right)\right) = \cos\left(\sin^{-1}\left(-\frac{1}{2}\right)\right)$

$= \cos\left(-\frac{\pi}{6}\right) = \frac{\sqrt{3}}{2}$

(d)  $\sin\left(\frac{\pi}{2} - \sin^{-1}\left(-\frac{\sqrt{3}}{2}\right)\right) = \cos\left(-\frac{\pi}{3}\right) = \frac{1}{2}$

(e)  $\sin(\cot^{-1}x) = \begin{cases} \sin\left(\sin^{-1}\frac{1}{\sqrt{1+x^2}}\right); & \text{if } x \geq 0 \\ \sin\left(\pi - \sin^{-1}\frac{1}{\sqrt{1+x^2}}\right); & \text{if } x < 0 \end{cases}$

$= \sin\left(\sin^{-1}\frac{1}{\sqrt{1+x^2}}\right) = \frac{1}{\sqrt{1+x^2}}$

3 (a) R.H.S. =  $2 \tan^{-1}(\operatorname{cosec}(\tan^{-1}x) - \tan(\cot^{-1}x))$

$= \begin{cases} 2 \tan^{-1}\left(\operatorname{cosec}\left(\operatorname{cosec}^{-1}\left(\frac{\sqrt{1+x^2}}{x}\right)\right) - \tan\left(\tan^{-1}\frac{1}{x}\right)\right); & \text{if } x > 0 \\ 2 \tan^{-1}\left(\operatorname{cosec}\left(\operatorname{cosec}^{-1}\left(\frac{\sqrt{1+x^2}}{x}\right)\right) - \tan\left(\pi + \tan^{-1}\frac{1}{x}\right)\right); & \text{if } x < 0 \end{cases}$

$= 2 \tan^{-1}\left(\frac{\sqrt{1+x^2}-1}{x}\right)$  if  $x \in \mathbb{R} - \{0\} = 2 \tan^{-1}\left(\frac{\sec \theta - 1}{\tan \theta}\right)$

Let  $\tan^{-1}x = \theta$ ;  $x = \tan \theta$

$= 2 \tan^{-1}\left(\frac{1 - \cos \theta}{\sin \theta}\right) = 2 \tan^{-1}\left(\tan \frac{\theta}{2}\right)$



Here  $\frac{\theta}{2} \in \left(-\frac{\pi}{4}, \frac{\pi}{4}\right) \sim \{0\}$

$\therefore \theta \in \left(-\frac{\pi}{2}, \frac{\pi}{2}\right) \sim \{0\}$

$= 2 \tan^{-1} \left( \tan \frac{\theta}{2} \right) = 2 \left( \frac{\theta}{2} \right) = \theta = \tan^{-1} x = \text{L.H.S.}$

(b)  $\sin(\cot^{-1}(\tan(\cos^{-1} x)))$

$$= \begin{cases} \sin \left( \cot^{-1} \left( \tan \left( \tan^{-1} \left( \frac{\sqrt{1-x^2}}{x} \right) \right) \right) \right); & \text{if } x \in (0, 1] \\ \sin \left( \cot^{-1} \left( \tan \left( \pi + \tan^{-1} \left( \frac{\sqrt{1-x^2}}{x} \right) \right) \right) \right); & \text{if } x \in [-1, 0) \end{cases}$$

$= \sin \left( \cot^{-1} \left( \frac{\sqrt{1-x^2}}{x} \right) \right)$  if  $x \in [-1, 1] \sim \{0\}$

$= \begin{cases} \sin(\sin^{-1} x); & \text{if } x \in (0, 1] \\ \sin(\pi + \sin^{-1} x); & \text{if } x \in [-1, 0) \end{cases} = \begin{cases} x; & \text{if } x \in (0, 1] \\ -x; & \text{if } x \in [-1, 0) \end{cases}$

(c) L.H.S. =  $\cos(\tan^{-1}(\sin(\cot^{-1} x)))$

$$= \begin{cases} \cos \left( \tan^{-1} \left( \sin \sin^{-1} \left( \frac{1}{\sqrt{1+x^2}} \right) \right) \right); & \text{if } x \geq 0 \\ \cos \left( \tan^{-1} \left( \sin \left( \pi - \sin^{-1} \frac{1}{\sqrt{1+x^2}} \right) \right) \right); & \text{if } x \leq 0 \end{cases}$$

$= \cos \left( \tan^{-1} \left( \frac{1}{\sqrt{1+x^2}} \right) \right) = \cos \left( \cos^{-1} \left( \frac{1}{\sqrt{1+\frac{1}{x^2+1}}} \right) \right)$

$= \sqrt{\frac{x^2+1}{x^2+2}}$

**Aliter:**

Let  $\cot^{-1} x = \theta \in (0, \pi)$

$\Rightarrow x = \cot \theta \quad \Rightarrow \sin \theta = \frac{1}{\sqrt{1+x^2}}$

L.H.S. =  $\cos \left( \tan^{-1} \frac{1}{\sqrt{1+x^2}} \right) = \cos \alpha$

Let  $\tan^{-1} \frac{1}{\sqrt{1+x^2}} = \alpha \Rightarrow \tan \alpha = \frac{1}{\sqrt{1+x^2}}$

$\Rightarrow \text{L.H.S.} = \cos \alpha = \frac{\sqrt{1+x^2}}{\sqrt{2+x^2}} = \text{R.H.S.}$

(d)  $\tan^{-1} x + \cot^{-1}(x+1) = \tan^{-1}(x^2+x+1)$  i.e., to prove that  $\tan(\tan^{-1} x + \cot^{-1}(x+1)) = x^2+x+1$

Let  $\tan^{-1} x = \theta$  and  $\cot^{-1}(x+1) = \phi$

$\Rightarrow \tan(\theta + \phi) = \frac{\tan \theta + \tan \phi}{1 - \tan \theta \tan \phi}$

$= \frac{x + \frac{1}{x+1}}{1 - x \left( \frac{1}{x+1} \right)} = \frac{x^2+x+1}{x+1} \cdot \frac{x+1}{1} = x^2+x+1$ , hence proved.

(e) Let  $\sin^{-1} \frac{x}{a} = \theta \Rightarrow x = a \sin \theta, a > 0$

L.H.S. =  $\tan^{-1} \left( \frac{x}{\sqrt{a^2-x^2}} \right) = \tan^{-1} \left( \frac{a \sin \theta}{|a| |\cos \theta|} \right)$

$\therefore \theta \in \left[-\frac{\pi}{2}, \frac{\pi}{2}\right]; \cos \theta > 0$

$= \tan^{-1} \left( \frac{a \sin \theta}{a \cos \theta} \right) = \tan^{-1}(\tan \theta) = \theta$

$\therefore \theta \in \left(-\frac{\pi}{2}, \frac{\pi}{2}\right) = \sin^{-1} \left( \frac{x}{a} \right) = \text{R.H.S.}$

(f) L.H.S. =  $\tan^{-1} \left( \frac{\cos x}{1 + \sin x} \right)$ ; where  $\frac{\pi}{2} < x < \frac{3\pi}{2}$

$= \tan^{-1} \left( \frac{\cos^2 \frac{x}{2} - \sin^2 \frac{x}{2}}{\left( \cos \frac{x}{2} + \sin \frac{x}{2} \right)^2} \right) = \tan^{-1} \left( \frac{\cos \frac{x}{2} - \sin \frac{x}{2}}{\cos \frac{x}{2} + \sin \frac{x}{2}} \right)$

$= \tan^{-1} \left( \frac{1 - \tan \frac{x}{2}}{1 + \tan \frac{x}{2}} \right) = \tan^{-1} \left( \tan \left( \frac{\pi}{4} - \frac{x}{2} \right) \right) = \left( \frac{\pi}{4} - \frac{x}{2} \right)$

$\therefore \frac{\pi}{4} - \frac{x}{2} \in \left(-\frac{\pi}{2}, 0\right) = \text{R.H.S.}$

4. (a)  $\cos^{-1} \left( \frac{1}{-3} \right) = \pi - \sin^{-1} \left( \sqrt{1 - \frac{1}{9}} \right) = \pi - \sin^{-1} \left( \frac{2\sqrt{2}}{3} \right)$

$= \cos^{-1} \left( \frac{-1}{3} \right) = \pi + \tan^{-1} \left( \frac{\sqrt{1-1/9}}{-1/3} \right) = \pi - \tan(2\sqrt{2})$

$= \cos^{-1} \left( \frac{-1}{3} \right) = \cot^{-1} \left( \frac{-1/3}{\sqrt{1-1/9}} \right)$

$= -\cot^{-1} \left( \frac{1}{2\sqrt{2}} \right) = \pi - \cot^{-1} \left( \frac{\sqrt{2}}{4} \right)$

(b)  $\tan^{-1} \left( -\frac{7}{24} \right) = \sin^{-1} \left( \frac{-\frac{7}{24}}{\sqrt{1 + \left( \frac{7}{24} \right)^2}} \right) = \sin^{-1} \left( \frac{-7}{\sqrt{625}} \right)$

$= -\sin^{-1} \left( \frac{7}{25} \right)$

Also  $\tan^{-1} \left( -\frac{7}{24} \right) = -\cos^{-1} \left( \frac{1}{\sqrt{1 + \left( \frac{7}{24} \right)^2}} \right) = -\cos^{-1} \left( \frac{24}{25} \right)$

Similarly  $\tan^{-1} \left( \frac{-7}{24} \right) = -\tan^{-1} \left( \frac{7}{24} \right) = -\cot^{-1} \left( \frac{24}{7} \right)$

$$\begin{aligned}
 \text{(c) } \cot^{-1}\left(\frac{-7}{24}\right) &= \pi - \cot^{-1}\left(\frac{7}{24}\right) = \pi - \tan^{-1}\left(\frac{24}{7}\right) \\
 &= \pi - \sin^{-1}\left(\frac{24/7}{\sqrt{1+\left(\frac{24}{7}\right)^2}}\right) = \pi - \sin^{-1}\left(\frac{24}{7} \times \frac{7}{25}\right) \\
 &= \pi - \sin^{-1}\left(\frac{24}{25}\right)
 \end{aligned}$$

5.  $\sin(\operatorname{cosec}^{-1}(\cot(\tan^{-1}x)))$

$$\begin{aligned}
 &= \begin{cases} \sin\left(\operatorname{cosec}^{-1}x\left(\cot\left(\cot^{-1}\frac{1}{x}\right)\right)\right); & \text{if } x > 0 \\ \sin\left(\operatorname{cosec}^{-1}\left(\cot\left(-\pi + \cot^{-1}\frac{1}{x}\right)\right)\right); & \text{if } x < 0 \end{cases} \\
 &= \begin{cases} \sin\left(\operatorname{cosec}^{-1}x\left(\frac{1}{x}\right)\right); & \text{if } x > 0 \\ \sin\left(\operatorname{cosec}^{-1}\left(\frac{1}{x}\right)\right); & \text{if } x < 0 \end{cases} \\
 &= x \text{ if } x \in \mathbb{R} \sim \{0\}
 \end{aligned}$$

$$\begin{aligned}
 \text{6. } y &= \tan^{-1}\left(\frac{\sqrt{1+x^2}-\sqrt{1-x^2}}{\sqrt{1+x^2}+\sqrt{1-x^2}}\right) \\
 \Rightarrow y &= \tan^{-1}\left(\frac{(1+x^2)+(1-x^2)-2\sqrt{1-x^4}}{2x^2}\right)
 \end{aligned}$$

$$\Rightarrow y = \tan^{-1}\left(\frac{1-\sqrt{1-x^4}}{x^2}\right)$$

$$\Rightarrow x^2 \tan y = 1 - \sqrt{1-x^4} \Rightarrow (1-x^2 \tan y)^2 = 1-x^4$$

$$\Rightarrow 1+x^4 \tan^2 y - 2x^2 \tan y = 1-x^4$$

$$\Rightarrow x^4 \sec^2 y = 2x^2 \tan y$$

$$\Rightarrow x^2 = 2 \sin y \cos y \Rightarrow x^2 = \sin 2y$$

Also when  $x = 0$  the original equation gives  $y = 0$

$$\Rightarrow x^2 = \sin 2y \quad \forall x \in (-1, 1]$$

7. L.H.S. =  $\operatorname{cosec}(\tan^{-1}(\cos \cot^{-1}(\sec(\sin^{-1} a))))$

$$\begin{aligned}
 &= \operatorname{cosec}\left(\tan^{-1}\left(\cos\left(\cot^{-1}\left(\sec\left(\sec^{-1}\frac{1}{\sqrt{1-a^2}}\right)\right)\right)\right)\right) \\
 &= \operatorname{cosec}\left(\tan^{-1}\left(\cos\left(\cot^{-1}\left(\frac{1}{\sqrt{1-a^2}}\right)\right)\right)\right) \\
 &= \operatorname{cosec}\left(\tan^{-1}\left(\cos\left(\cos^{-1}\left(\frac{1}{\sqrt{1-a^2}} \cdot \frac{1}{\sqrt{1+\frac{1}{1-a^2}}}\right)\right)\right)\right) \\
 &= \operatorname{cosec}\left(\tan^{-1}\left(\frac{1}{\sqrt{2-a^2}}\right)\right)
 \end{aligned}$$

$$= \operatorname{cosec}\left(\operatorname{cosec}^{-1}\left(\frac{\sqrt{1+\frac{1}{2-a^2}}}{\sqrt{2-a^2}}\right)\right) = \sqrt{3-a^2}$$

$$\text{R.H.S.} = \sec(\cot^{-1}(\sin(\tan^{-1}(\operatorname{cosec}(\cos^{-1} a))))))$$

$$= \sec\left(\cot^{-1}\left(\sin\left(\tan^{-1}\left(\frac{1}{\sqrt{1-a^2}}\right)\right)\right)\right)$$

$$= \sec\left(\cot^{-1}\left(\sin\left(\sin^{-1}\left(\frac{1/\sqrt{1-a^2}}{\sqrt{1+\left(\frac{1}{\sqrt{1-a^2}}\right)^2}}\right)\right)\right)\right)$$

$$= \sec\left(\cot^{-1}\left(\frac{1}{\sqrt{2-a^2}}\right)\right) = \sec\left(\sec^{-1}\left(\frac{\sqrt{1+\frac{1}{2-a^2}}}{\sqrt{2-a^2}}\right)\right)$$

$$= \sec\left(\sec^{-1}\left(\sqrt{3-a^2}\right)\right) = \sqrt{3-a^2}. \text{ Clearly L.H.S.} = \text{R.H.S.}$$

8.  $\sin(\cot^{-1}(x+1)) = \cos(\tan^{-1}x) \dots$  (i)

$$\text{L.H.S.} = \begin{cases} \sin\left(\sin^{-1}\frac{1}{\sqrt{1+(x+1)^2}}\right) & \text{if } x+1 \geq 0 \\ \sin\left(\pi - \sin^{-1}\frac{1}{\sqrt{1+(x+1)^2}}\right) & \text{if } x+1 < 0 \end{cases}$$

$$= \frac{1}{\sqrt{x^2+2x+2}} = \begin{cases} \cos\left(\cos^{-1}\frac{1}{\sqrt{1+x^2}}\right) & x \in [0, \infty) \\ \cos\left(-\cos^{-1}\frac{1}{\sqrt{1+x^2}}\right) & x \in (-\infty, 0] \end{cases}$$

$$\text{Similarly R.H.S.} = \begin{cases} \cos\left(\cos^{-1}\frac{1}{\sqrt{1+x^2}}\right) & x \in [0, \infty) \\ \cos\left(-\cos^{-1}\frac{1}{\sqrt{1+x^2}}\right) & x \in (-\infty, 0] \end{cases} = \frac{1}{\sqrt{1+x^2}}$$

Thus solving (i), we get  $\sqrt{x^2+2x+2} = \sqrt{1+x^2}$

$$\Rightarrow x^2+2x+2 = x^2+1$$

$$\Rightarrow 2x+1 = 0$$

$$\Rightarrow x = -1/2 \text{ is only solution}$$

9.  $\cos(\cot^{-1}x) = \cos\left(\cos^{-1}\frac{x}{\sqrt{1+x^2}}\right) = \frac{x}{\sqrt{1+x^2}} \quad \forall x \in \mathbb{R}$

Also  $\sin(\cot^{-1}x)$

$$= \begin{cases} \sin\left(\sin^{-1}\frac{1}{\sqrt{1+x^2}}\right) & \text{if } x \geq 0 \\ \sin\left(\pi - \sin^{-1}\frac{1}{\sqrt{1+x^2}}\right) & \text{if } x < 0 \end{cases}$$

$$= \frac{1}{\sqrt{1+x^2}} \quad \forall x \in \mathbb{R}$$

Thus the expression given reduces to

$$\sqrt{1+x^2} \left[ \left( \frac{x^2}{\sqrt{1+x^2}} + \frac{1}{\sqrt{1+x^2}} \right)^2 - 1 \right]^{1/2} = \sqrt{1+x^2} \sqrt{(1+x^2)-1}$$

$$= \sqrt{x^2+1} \sqrt{x^2} = |x| \sqrt{x^2+1}$$

10. (a) L.H.S. =  $\tan\left(\frac{1}{2}\cos^{-1}\left(\frac{\sqrt{5}}{3}\right)\right) = \tan\left(\frac{\theta}{2}\right)$  say

$$\Rightarrow \cos^{-1}\left(\frac{\sqrt{5}}{3}\right) = \theta \in [0, \pi)$$

$$\Rightarrow \frac{\sqrt{5}}{3} = \cos\theta = \frac{1 - \tan^2\theta/2}{1 + \tan^2\theta/2}$$

Applying componendo and dividendo, we get

$$\frac{\sqrt{5}-3}{\sqrt{5}+3} = -\tan^2\frac{\theta}{2}$$

$$\Rightarrow \tan^2\frac{\theta}{2} = \frac{3-\sqrt{5}}{3+\sqrt{5}} \Rightarrow \tan^2\frac{\theta}{2} = \frac{(3-\sqrt{5})^2}{4}$$

$$\Rightarrow \tan^2\frac{\theta}{2} = \frac{3-\sqrt{5}}{2} \quad \therefore \frac{\theta}{2} \in \left(0, \frac{\pi}{2}\right)$$

(b) L.H.S. =  $\sin(\tan^{-1}2) + \cos(\tan^{-1}2)$   
 =  $\sin\left(\sin^{-1}\left(\frac{2}{\sqrt{5}}\right)\right) + \cos\left(\cos^{-1}\left(\frac{1}{\sqrt{5}}\right)\right)$   
 =  $\frac{2}{\sqrt{5}} + \frac{1}{\sqrt{5}} = \frac{3}{\sqrt{5}} = \text{R.H.S.}$

**TEXTUAL EXERCISE-3 (OBJECTIVE)**

1. (b) Let  $\sin\left(\sin^{-1}\frac{1}{2} + \cos^{-1}\frac{1}{3}\right) = \sin(\theta + \phi)$ ;

Where  $\theta = \sin^{-1}\frac{1}{2} \Rightarrow \sin\theta = \frac{1}{2}$

$\phi = \cos^{-1}\frac{1}{3}$  and  $\cos\phi = \frac{1}{3}$

=  $\sin\theta \cos\phi + \cos\theta \sin\phi = \frac{1}{2} \cdot \frac{1}{3} + \frac{\sqrt{3}}{2} \cdot \frac{2\sqrt{2}}{3}$

$\therefore \theta \in \left(0, \frac{\pi}{2}\right)$  and  $\theta \in (0, \pi) = \frac{1+2\sqrt{6}}{6}$

2. (b)  $f(x) = e^{\cos(\cos^{-1}x^2) + \tan(\cot^{-1}x^2)} = e^{x^2 + \frac{1}{x^2}} \geq e^2$

$\therefore x^2 + \frac{1}{x^2} \geq 2$ ; AM  $\geq$  GM

3. (b, c)  $\therefore \cos^{-1}x = \begin{cases} \sin^{-1}\sqrt{1-x^2}; & \text{if } 0 \leq x \leq 1 \\ \pi - \sin^{-1}\sqrt{1-x^2}; & \text{if } -1 \leq x \leq 0 \end{cases}$

Replacing x by (2x - 1) we get,

$$\cos^{-1}(2x-1) = \begin{cases} \sin^{-1}(2\sqrt{x-x^2}); & \text{if } \frac{1}{2} \leq x \leq 1 \\ \pi - \sin^{-1}(2\sqrt{x-x^2}); & \text{if } 0 \leq x \leq \frac{1}{2} \end{cases}$$

4. (a, b)  $\therefore \sin^{-1}x = \begin{cases} -\cos^{-1}\sqrt{1-x^2}; & \text{if } -1 \leq x \leq 0 \\ \cos^{-1}\sqrt{1-x^2}; & \text{if } 0 \leq x \leq 1 \end{cases}$ ;

Replacing x by  $\frac{2x+1}{3}$  we get

$$\sin^{-1}\left(\frac{2x+1}{3}\right) = \begin{cases} -\cos^{-1}\left(\frac{2}{3}\sqrt{2-x-x^2}\right); & \text{if } -2 \leq x \leq -\frac{1}{2} \\ \cos^{-1}\left(\frac{2}{3}\sqrt{2-x-x^2}\right); & \text{if } -\frac{1}{2} \leq x \leq 1 \end{cases}$$

5. (c, d)  $\therefore \cos^{-1}x = \begin{cases} \tan^{-1}\left(\frac{\sqrt{1-x^2}}{x}\right); & \text{if } x \in (0, 1] \\ \pi + \tan^{-1}\left(\frac{\sqrt{1-x^2}}{x}\right); & \text{if } x \in [-1, 0) \end{cases}$ ;

Replacing x  $\rightarrow \frac{x+1}{2}$  we get,

$$\cos^{-1}\left(\frac{x+1}{2}\right) = \begin{cases} \tan^{-1}\left(\frac{\sqrt{3-x(2+x)}}{x+1}\right); & \text{if } -1 < x \leq 1 \\ \pi + \tan^{-1}\left(\frac{\sqrt{3-2x-x^2}}{x+1}\right); & \text{if } -3 \leq x < -1 \end{cases}$$

6. (a, c)  $\cos(\sin^{-1}x) = \begin{cases} \cos(\cos^{-1}\sqrt{1-x^2}); & \text{if } 0 < x \leq 1 \\ \cos(-\cos^{-1}\sqrt{1-x^2}); & \text{if } -1 \leq x \leq 0 \end{cases}$

=  $\sqrt{1-x^2} \quad \forall x \in [-1, 1]$

$$\sin(\cos^{-1}x) = \begin{cases} \sin(\sin^{-1}\sqrt{1-x^2}); & \text{if } 0 \leq x \leq 1 \\ \sin(\pi - \sin^{-1}\sqrt{1-x^2}); & \text{if } -1 \leq x \leq 0 \end{cases}$$

=  $\sqrt{1-x^2} \quad \forall x \in [-1, 1]$

Thus  $(\cos(\sin^{-1}x))^2 = (\sin(\cos^{-1}x))^2$

=  $1 - x^2 \quad \forall x \in [-1, 1]$

$\therefore$  Option (a) is correct.

$(\cos(\cos^{-1}x))^2 = x^2 \Rightarrow (\sin(\cos^{-1}x))^2 = 1 - x^2$

$\therefore$  Option (b) is incorrect.

$(\sin(\sin^{-1}x))^2 = (\cos(\cos^{-1}x))^2 = x^2 \quad \forall x \in [-1, 1]$

$\therefore$  Option (c) is correct.

$(\sin(\cos^{-1}x))^2 = 1 - x^2$

$\Rightarrow \left(\frac{\pi}{2}\sin(\sin^{-1}x)\right)^2 = \frac{\pi^2 x^2}{4}$

$\therefore$  Option (d) is incorrect.

7. (a, d)  $\cos^{-1}\left(\frac{1}{x}\right) = \theta \in [0, \pi] \sim \left\{\frac{\pi}{2}\right\}$

$\Rightarrow \sec^{-1}x = \theta \Rightarrow x = \sec\theta$

$\Rightarrow x^2 - 1 = \sec^2\theta - 1 \Rightarrow x^2 - 1 = \tan^2\theta$

$$\Rightarrow \sqrt{x^2-1} = |\tan \theta|$$

$$\Rightarrow \tan \theta = \begin{cases} \sqrt{x^2-1} & \text{if } \theta \in \left[0, \frac{\pi}{2}\right) \\ -\sqrt{x^2-1}; & \text{if } \theta \in \left[\frac{\pi}{2}, \pi\right) \end{cases}$$

8. (c) Let  $\sin^{-1}x = \theta \in \left[-\frac{\pi}{2}, \frac{\pi}{2}\right]$

$$\Rightarrow \cos(2\theta) = \frac{1}{9} \Rightarrow 1 - 2\sin^2 \theta = \frac{1}{9}$$

$$\Rightarrow 2(\sin(\sin^{-1}x))^2 = \frac{8}{9} \Rightarrow x^2 = 4/9$$

$$\Rightarrow x = \pm 2/3$$

9. (a) Let  $\tan^{-1}\frac{1}{3} = A$  and  $\tan^{-1}\frac{1}{2} = B$

Clearly  $A, B \in \left(0, \frac{\pi}{2}\right)$  and  $\tan A = 1/3, \tan B = 1/2$

$$\begin{aligned} \cos\left(\tan^{-1}\frac{1}{3} + \tan^{-1}\frac{1}{2}\right) &= \cos(A+B) = \cos A \cos B - \sin A \sin B \\ &= \left(\frac{3}{\sqrt{10}} \times \frac{2}{\sqrt{5}}\right) - \left(\frac{1}{\sqrt{10}} \times \frac{1}{\sqrt{5}}\right) = \frac{5}{\sqrt{10}\sqrt{5}} = \frac{\sqrt{5}}{\sqrt{10}} = \frac{1}{\sqrt{2}} \end{aligned}$$

10. (d) Let  $\tan^{-1}(1/5) = \theta \Rightarrow \tan \theta = 1/5$

$$\begin{aligned} \tan\left[2\tan^{-1}\left(\frac{1}{5}\right) - \frac{\pi}{4}\right] &= \tan\left(2\theta - \frac{\pi}{4}\right) = \frac{\tan 2\theta - 1}{1 + \tan 2\theta} \\ &= \frac{\frac{5}{12} - 1}{1 + \frac{5}{12}} = \frac{-7}{17} \quad \therefore \tan 2\theta = \frac{2 \tan \theta}{1 - \tan^2 \theta} = \frac{2}{5} \times \frac{25}{24} = \frac{5}{12} \end{aligned}$$

11. (b) Let  $\cos^{-1}\left(\frac{1}{5}\right) = \theta \Rightarrow \cos \theta = \frac{1}{5}$ ,

$$\sin\left(\frac{\pi}{2} - \theta\right) = \frac{1}{5} \Rightarrow \frac{\pi}{2} - \theta = \sin^{-1}\frac{1}{5}$$

$$\begin{aligned} \cos\left[2\cos^{-1}\frac{1}{5} + \sin^{-1}\frac{1}{5}\right] &= \cos\left[2\theta + \frac{\pi}{2} - \theta\right] \\ &= \cos\left[\frac{\pi}{2} + \theta\right] = -\sin \theta \quad \because \theta \in \left(0, \frac{\pi}{2}\right) \\ &= -\sqrt{1 - \cos^2 \theta} = -\sqrt{1 - \frac{1}{25}} = -\sqrt{\frac{24}{25}} = \frac{-2\sqrt{6}}{5} \end{aligned}$$

12. (a) Let  $\cos^{-1}\left(\frac{\sqrt{5}}{3}\right) = \theta$

$$\Rightarrow \cos \theta = \frac{\sqrt{5}}{3}$$

$$\tan\left(\frac{1}{2}\cos^{-1}\left(\frac{\sqrt{5}}{3}\right)\right) = \tan\left(\frac{\theta}{2}\right)$$

$$\Rightarrow \frac{\sqrt{5}}{3} = \cos \theta = \frac{1 - \tan^2 \frac{\theta}{2}}{1 + \tan^2 \frac{\theta}{2}}$$

Applying componendo and dividendo, we get

$$\frac{\sqrt{5}-3}{\sqrt{5}+3} = -\tan^2 \frac{\theta}{2}$$

$$\Rightarrow \tan^2 \frac{\theta}{2} = \frac{3-\sqrt{5}}{3+\sqrt{5}} \Rightarrow \tan^2 \frac{\theta}{2} = \frac{(3-\sqrt{5})^2}{4}$$

$$\Rightarrow \left|\tan \frac{\theta}{2}\right| = \frac{3-\sqrt{5}}{2}$$

$$\therefore \theta \in \left(0, \frac{\pi}{2}\right); \frac{\theta}{2} \in \left(0, \frac{\pi}{4}\right)$$

$$\Rightarrow \tan \frac{\theta}{2} = \frac{3-\sqrt{5}}{2}$$

13. (d)  $\sin\left(\sin^{-1}\frac{1}{5} + \cos^{-1}x\right) = 1 \dots (i)$

$$\text{Let } \theta = \sin^{-1}\frac{1}{5} \Rightarrow \sin \theta = \frac{1}{5}$$

$$\phi = \cos^{-1}x \Rightarrow \cos \phi = x$$

Clearly  $\theta \in \left(0, \frac{\pi}{2}\right)$  and  $\phi \in (0, \pi)$

Equation (i) becomes  $\sin(\theta + \phi) = 1$

$$\Rightarrow \sin \theta \cos \phi + \cos \theta \sin \phi = 1$$

$$\Rightarrow \frac{1}{5}(x) + \frac{2\sqrt{6}}{5}\sqrt{1-x^2} = 1$$

$$\Rightarrow 2\sqrt{6}\sqrt{1-x^2} = 5-x$$

Squaring both sides we get,  $24 - 24x^2 = 25 + x^2 - 10x$

$$\Rightarrow 25x^2 - 10x + 1 = 0 \Rightarrow (5x-1)^2 = 0$$

$$\Rightarrow x = \frac{1}{5}$$

14. (c)  $x^2 - x - \pi + \sin^{-1}(\sin 2) < 0$

$$\therefore 2 \in \left(\frac{\pi}{2}, \pi\right); \sin^{-1}(\sin 2) = \pi - 2$$

Thus the above inequality reduces to  $x^2 - x - 2 < 0$

$$\Rightarrow (x-2)(x+1) < 0 \Rightarrow x \in (-1, 2)$$

**TEXTUAL EXERCISE-4 (SUBJECTIVE)**

1.  $\cot^{-1}x + \tan^{-1}3 = \pi/2$

$$\Rightarrow \cot^{-1}x = \frac{\pi}{2} - \tan^{-1}3 \Rightarrow \cot^{-1}x = \cot^{-1}3$$

$\Rightarrow x = 3$  is only solution.

2.  $\sin^{-1}\frac{2a}{1+a^2} = 2\tan^{-1}a; \sin^{-1}\frac{2b}{1+b^2} = 2\tan^{-1}b$

The equation reduces to  $\tan^{-1}a + \tan^{-1}b = \tan^{-1}x$

Taking tan on both sides, we get,  $\tan(\tan^{-1}a + \tan^{-1}b) = \tan(\tan^{-1}x)$

$$\Rightarrow \frac{a+b}{1-ab} = x$$

3. If  $x \in (0, 1)$

$$\sin\left[\cot^{-1}\frac{2x}{1-x^2} + \cos^{-1}\frac{1-x^2}{1+x^2}\right]$$

4.110 > Trigonometry

$$= \sin \left[ \frac{\pi}{2} - \tan^{-1} \frac{2x}{1-x^2} + \cos^{-1} \frac{1-x^2}{1+x^2} \right]$$

$$= \sin \left[ \frac{\pi}{2} - 2 \tan^{-1} x + 2 \tan^{-1} x \right] = 1$$

If  $x \in (1, \infty)$

$$\tan^{-1} \left( \frac{1-x^2}{2x} \right) = -\pi + \cot^{-1} \frac{2x}{1-x^2} = -\pi + \frac{\pi}{2} - \tan^{-1} \frac{2x}{1-x^2}$$

$$= -\frac{\pi}{2} - (-\pi + 2 \tan^{-1} x) = \frac{\pi}{2} - 2 \tan^{-1} x$$

Where as  $\cos^{-1} \frac{1-x^2}{1+x^2} = 2 \tan^{-1} x$ .

Therefore  $\sin \left( \tan^{-1} \frac{1-x^2}{2x} + \cos^{-1} \frac{1-x^2}{1+x^2} \right) = \sin \left( \frac{\pi}{2} \right) = 1$

$\Rightarrow \forall x > 0$  the expression takes constant value 1.

4. As we know that  $\sin^{-1} \frac{2x}{1+x^2} = \begin{cases} -\pi - 2 \tan^{-1} x, & x < -1 \\ 2 \tan^{-1} x, & -1 \leq x \leq 1 \\ \pi - 2 \tan^{-1} x, & x > 1 \end{cases}$

and  $\cos^{-1} \frac{1-x^2}{1+x^2} = \begin{cases} 2 \tan^{-1} x, & x \in (0, \infty) \\ -2 \tan^{-1} x, & x \in (-\infty, 0) \end{cases}$

Let  $\theta = \frac{1}{2} \sin^{-1} \frac{2x}{1+x^2} + \frac{1}{2} \cos^{-1} \frac{1-x^2}{1+x^2}$ . Thus for  $x \in [0, 1]$

$\theta = 2 \tan^{-1} x$

$\tan \theta = \tan(2 \tan^{-1} x) = \frac{2 \tan(\tan^{-1} x)}{1 - (\tan(\tan^{-1} x))^2} = \frac{2x}{1-x^2}$

5.  $\cos^{-1} \left( \frac{1-a^2}{1+a^2} \right) - \cos^{-1} \left( \frac{1-b^2}{1+b^2} \right) = 2 \tan^{-1} x$

$\Rightarrow 2 \tan^{-1} a - 2 \tan^{-1} b = 2 \tan^{-1} x$

Taking tan on both side we get,  $\tan(\tan^{-1} a - \tan^{-1} b) = \tan(\tan^{-1} x)$

$\Rightarrow \frac{a-b}{1+ab} = x$

6.  $\therefore \tan^{-1} \frac{2x}{1-x^2} = \begin{cases} \pi + 2 \tan^{-1} x, & x < -1 \\ 2 \tan^{-1} x, & -1 < x < 1 \\ -\pi + 2 \tan^{-1} x, & x > 1 \end{cases}$

$\cos^{-1} \left( \frac{1-x^2}{1+x^2} \right) = \begin{cases} 2 \tan^{-1} x & \text{if } x > 0 \\ -2 \tan^{-1} x & \text{if } x < 0 \end{cases}$

The equation reduces to

$\pi - \cos^{-1} \left( \frac{1-x^2}{1+x^2} \right) - \tan^{-1} \frac{2x}{1-x^2} = \frac{2\pi}{3}$

$\Rightarrow \cos^{-1} \left( \frac{1-x^2}{1+x^2} \right) + \tan^{-1} \left( \frac{2x}{1-x^2} \right) = \frac{\pi}{3}$

$\Rightarrow \begin{cases} -2 \tan^{-1} x + \pi + 2 \tan^{-1} x = \frac{\pi}{3}; & x \in (-\infty, -1) \\ -2 \tan^{-1} x + 2 \tan^{-1} x = \frac{\pi}{3}; & x \in (-1, 0) \\ 2 \tan^{-1} x + 2 \tan^{-1} x = \frac{\pi}{3}; & x \in [0, 1) \\ 2 \tan^{-1} x - \pi + 2 \tan^{-1} x = \frac{\pi}{3}; & x \in (1, \infty) \end{cases}$

$\Rightarrow \tan^{-1} x = \frac{\pi}{2}$ ; Thus  $x = \tan \left( \frac{\pi}{2} \right)$  is solution

$\Rightarrow \tan^{-1} x = \frac{\pi}{3} \Rightarrow x = \sqrt{3}$  is solution.

7. (a)  $4 \sin^{-1} x + \cos^{-1} x = \frac{3\pi}{4}$

$\Rightarrow 4 \sin^{-1} x + \frac{\pi}{2} - \sin^{-1} x = \frac{3\pi}{4}$

$\Rightarrow 3 \sin^{-1} x = \frac{\pi}{4} \Rightarrow \sin^{-1} x = \frac{\pi}{12}$

$\Rightarrow x = \sin \left( \frac{\pi}{12} \right) = \sin \left( \frac{\pi}{3} - \frac{\pi}{4} \right) = \frac{\sqrt{3}}{2\sqrt{2}} - \frac{1}{2\sqrt{2}} = \frac{\sqrt{3}-1}{2\sqrt{2}}$

(b)  $5 \tan^{-1} x + 3 \left( \frac{\pi}{2} - \tan^{-1} x \right) = \frac{7\pi}{4}$

$\Rightarrow 2 \tan^{-1} x = \frac{7\pi}{4} - \frac{3\pi}{2} \Rightarrow \tan^{-1} x = \frac{\pi}{8}$

$\Rightarrow x = \tan \frac{\pi}{8} > 0 \Rightarrow \tan \frac{\pi}{4} = \frac{2x}{1-x^2}$

$\Rightarrow x^2 + 2x - 1 = 0$

$\Rightarrow x = \frac{-2 \pm \sqrt{8}}{2}$ ; rejecting negative -ve sign

$\Rightarrow x = \sqrt{2} - 1$ .

8. (i) L.H.S. =  $\sin \left( 2 \sin^{-1} \frac{3}{5} \right)$

$\Rightarrow \sin \left( \pi - \sin^{-1} \left( 2 \left( \frac{3}{5} \right) \sqrt{1 - \frac{9}{25}} \right) \right)$

$\Rightarrow \frac{6}{5} \sqrt{\frac{16}{25}} = \frac{24}{25} = \text{R.H.S.}$

(ii) L.H.S. =  $\cos(2 \tan^{-1} 2) + \sin(2 \tan^{-1} 3)$

$= \cos \left( \cos^{-1} \left( \frac{1-4}{1+4} \right) \right) + \sin \left( \pi - \sin^{-1} \left( \frac{2\sqrt{3}}{1+3^2} \right) \right)$

$= \frac{-3}{5} + 5 \left( \frac{6}{10} \right) = 0$

9. Let  $y = 2 \tan^{-1} x + \sin^{-1} \frac{2x}{1+x^2}$ . Let  $\tan^{-1} x = \theta \in \left( -\frac{\pi}{2}, \frac{\pi}{2} \right)$

$y = 2\theta + \sin^{-1}(\sin 2\theta) =$

$\begin{cases} 2\theta + (-2\theta - \pi); & \text{if } 2\theta \in \left( -\pi, \frac{\pi}{2} \right) \\ 4\theta; & \text{if } 2\theta \in \left( -\frac{\pi}{2}, \frac{\pi}{2} \right) \\ 2\theta + \pi - 2\theta; & \text{if } 2\theta \in \left( \frac{\pi}{2}, \pi \right) \end{cases}$

Clearly y is independent of x i.e., independent of  $\theta$  if

$\theta \in \left( -\frac{\pi}{2}, -\frac{\pi}{4} \right) \cup \left( \frac{\pi}{4}, \frac{\pi}{2} \right)$

$\Rightarrow \tan \theta \in (-\infty, -1) \cup (1, \infty)$  i.e.,  $x \in (-\infty, -1) \cup (1, \infty)$

$$\begin{aligned}
 \text{10. (a) Given } & \left| \frac{\pi}{2} - \sin^{-1} \left( \frac{1-x^2}{1+x^2} \right) \right| < \frac{\pi}{3} \\
 \Rightarrow & \left| \cos^{-1} \frac{1-x^2}{1+x^2} \right| < \frac{\pi}{3} \\
 \Rightarrow & \begin{cases} |2 \tan^{-1} x| < \frac{\pi}{3}; & x \geq 0 \\ |-2 \tan^{-1} x| < \frac{\pi}{3}; & x < 0 \end{cases} \\
 \Rightarrow & -\frac{\pi}{6} < \tan^{-1} x < \frac{\pi}{6} \quad \Rightarrow \quad -\frac{1}{\sqrt{3}} \leq x < \frac{1}{3}
 \end{aligned}$$

$$\begin{aligned}
 \text{(b) Given } & \sin^{-1} \left( \sin \left( \frac{2x^2+4}{1+x^2} \right) \right) < \pi - 3 \\
 \therefore & \frac{2x^2+4}{1+x^2} \in (2, 4] \subset \left[ \frac{\pi}{2}, \frac{3\pi}{2} \right]
 \end{aligned}$$

$$\Rightarrow \left( \sin^{-1} \left( \frac{2x^2+4}{1+x^2} \right) \right) = \pi - \frac{2x^2+4}{x^2+1}$$

Therefore the inequality becomes  $\pi - \frac{2x^2+4}{x^2+1} < \pi - 3$

$$\Rightarrow -\left(2 + \frac{2}{x^2+1}\right) < -3$$

$$\Rightarrow \frac{2}{x^2+1} > 1 \quad \Rightarrow \quad x^2 < 1$$

$$\Rightarrow x \in (-1, 1)$$

$$\text{11. As } a, \beta \in \left(0, \frac{\pi}{2}\right)$$

$$\Rightarrow \frac{\alpha}{2}, \frac{\beta}{2} \in \left(0, \frac{\pi}{4}\right)$$

$$\Rightarrow \tan \frac{\alpha}{2} \in (0, 1) \text{ and } \tan \left(\frac{\pi}{4} - \frac{\beta}{2}\right) \in (0, 1)$$

$$\Rightarrow \tan \frac{\alpha}{2} \cdot \tan \left(\frac{\pi}{4} - \frac{\beta}{2}\right) \in (0, 1). \text{ Let it equal to } t.$$

$$\text{L.H.S.} = 2 \tan^{-1}(t) = \tan^{-1} \left( \frac{2t}{1-t^2} \right)$$

$$\begin{aligned}
 & = \tan^{-1} \left( \frac{2 \tan \frac{\alpha}{2} \left( \frac{1 - \tan \frac{\beta}{2}}{1 + \tan \frac{\beta}{2}} \right)}{1 - \tan^2 \frac{\alpha}{2} \left( \frac{1 - \tan \frac{\beta}{2}}{1 + \tan \frac{\beta}{2}} \right)^2} \right) \\
 & = \tan^{-1} \left( \frac{2 \tan \frac{\alpha}{2} \left( 1 - \tan^2 \frac{\beta}{2} \right)}{\left( 1 + \tan \frac{\beta}{2} \right)^2 - \left( \tan \frac{\alpha}{2} - \tan \frac{\alpha}{2} + \tan \frac{\beta}{2} \right)^2} \right)
 \end{aligned}$$

$$\begin{aligned}
 & = \tan^{-1} \left( \frac{\frac{2 \sin \frac{\alpha}{2} \cos \beta}{\cos^2 \frac{\beta}{2}}}{\sec^2 \frac{\beta}{2} + 2 \tan \frac{\beta}{2} - \tan^2 \frac{\alpha}{2} \left( \sec^2 \frac{\beta}{2} - 2 \tan \frac{\beta}{2} \right)} \right) \\
 & = \tan^{-1} \left( \frac{2 \sin \frac{\alpha}{2} \cos \beta}{1 + 2 \sin \frac{\beta}{2} \cos \frac{\beta}{2} - \tan^2 \frac{\alpha}{2} \left( 1 - 2 \sin \frac{\beta}{2} \cos \frac{\beta}{2} \right)} \right) \\
 & = \tan^{-1} \left( \frac{2 \sin \frac{\alpha}{2} \cos \beta}{\left( 1 - \tan^2 \frac{\alpha}{2} \right) + \sin \beta \left( \sec^2 \frac{\alpha}{2} \right)} \right) \\
 & = \tan^{-1} \left( \frac{2 \sin \frac{\alpha}{2} \cos \beta \cos^2 \frac{\alpha}{2}}{\cos \alpha + \sin \beta} \right) = \tan^{-1} \left( \frac{\sin \alpha \cos \beta}{\cos \alpha + \sin \beta} \right)
 \end{aligned}$$

$$\begin{aligned}
 \text{12. } 3 \sin^{-1} & = \begin{cases} 3(-\pi - 2 \tan^{-1} x); & \text{if } x < -1 \\ 6 \tan^{-1} x; & \text{if } -1 < x < 1 \\ 3(\pi - 2 \tan^{-1} x); & \text{if } x > 1 \end{cases} \\
 & = -4 \cos^{-1} \left( \frac{1-x^2}{1+x^2} \right) = \begin{cases} -8 \tan^2 x; & \text{if } x > 0 \\ 8 \tan^{-1} x; & \text{if } x < 0 \end{cases} \\
 & = 2 \tan^{-1} \left( \frac{2x}{1-x^2} \right) = \begin{cases} -\pi + 4 \tan^{-1} x; & \text{if } x < -1 \\ 4 \tan^{-1} x; & \text{if } -1 < x < 1 \\ \pi + 4 \tan^{-1} x; & \text{if } x > 1 \end{cases}
 \end{aligned}$$

Adding the above three functions we get,

$$\begin{cases} \frac{\pi}{3} = -4\pi - 6 \tan^{-1} x; & \text{if } x < -1 \\ \frac{\pi}{3} = 18 \tan^{-1} x; & \text{if } -1 < x < 0 \\ \frac{\pi}{3} = 2 \tan^{-1} x; & \text{if } 0 < x < 1 \\ \frac{\pi}{3} = 4\pi - 10 \tan^{-1} x; & \text{if } x > 1 \end{cases}$$

$$\Rightarrow \begin{cases} \tan^{-1} x = -\frac{13\pi}{18}; & \text{if } x < -1 \\ \tan^{-1} x = \frac{\pi}{54}; & \text{if } -1 < x < 0 \\ \tan^{-1} x = \frac{\pi}{6}; & \text{if } 0 < x < 1 \\ \tan^{-1} x = \frac{11\pi}{30}; & \text{if } x > 1 \end{cases}$$

$$\Rightarrow x = -\tan \frac{13\pi}{18}, \frac{1}{\sqrt{3}}, \tan \frac{11\pi}{30}$$

$$\begin{aligned}
 \text{13. Let } \tan^{-1} x & = p \text{ and } \tan^{-1} y = q, \text{ clearly } p + q = \frac{\pi}{2} \quad \dots(i) \\
 y & = (\tan^{-1} x)^3 + (\tan^{-1} y)^3 = p^3 + q^3 = (p+q)^3 - (3pq(p+q))
 \end{aligned}$$

4.112 > Trigonometry

$$= \left(\frac{\pi}{2}\right)^3 - \frac{3\pi}{2} \left(p \left(\frac{\pi}{2} - p\right)\right) = \frac{\pi^3}{8} - \frac{3\pi}{8} (2p(\pi - 2p))$$

$$= \frac{\pi}{8} (\pi^2 - 16p\pi + 12p^2)$$

$$= \frac{12\pi}{8} \left(p^2 - \frac{p\pi}{2} + \frac{\pi^2}{12}\right) = \frac{3\pi}{2} \left(\left(p - \frac{\pi}{4}\right)^2 + \frac{\pi^2}{48}\right)$$

Now,  $\therefore -\frac{\pi}{2} < p < \frac{\pi}{2}$ ;  $-\frac{3\pi}{4} < p - \frac{\pi}{4} < \frac{\pi}{4}$ ;

$$0 \leq \left(p - \frac{\pi}{4}\right)^2 \leq \frac{9\pi^2}{16}$$

$$\Rightarrow \frac{\pi^2}{48} \leq \frac{\pi^2}{48} + \left(p - \frac{\pi}{4}\right)^2 < \frac{28\pi^2}{48}$$

$$\Rightarrow y \in \left[\frac{\pi^3}{32}, \frac{7\pi^3}{8}\right]$$

14.  $p = \sin^{-1}x$  and  $q = \cos^{-1}x$

$$p + q = \pi/2$$

$$y = p^2 + q^2 = (p + q)^2 - 2pq = \frac{\pi^2}{4} - 2p \left(\frac{\pi}{2} - p\right)$$

$$= 2p^2 - px + \pi^2/4 = 2 \left(\left(p - \frac{\pi}{4}\right)^2 + \frac{\pi^2}{16}\right)$$

$$\therefore 0 \leq \left(p - \frac{\pi}{4}\right)^2 \leq \frac{9\pi^2}{16}$$

$$\Rightarrow \frac{\pi^2}{16} \leq \frac{\pi^2}{16} + \left(p - \frac{\pi}{4}\right)^2 \leq \frac{5\pi^2}{8} \Rightarrow y \in \left[\frac{\pi^2}{8}, \frac{5\pi^2}{4}\right]$$

15. Let  $\sin^{-1}x = p$  and  $\cos^{-1}x = q$

$$p^3 + q^3 = a\pi^3$$

$$\Rightarrow \frac{\pi}{2} \left(\frac{\pi^2}{4} - 3p \left(\frac{\pi}{2} - p\right)\right) = a\pi^3$$

$$\Rightarrow \frac{\pi^2}{4} - \frac{3\pi p}{2} + 3p^2 = 2a\pi^2$$

$$\Rightarrow p^2 - \frac{\pi p}{2} + \frac{\pi^2}{12} - \frac{\pi^2}{3} = 0$$

$$\Rightarrow \left(p - \frac{\pi}{4}\right)^2 + \frac{\pi^2}{12} - \frac{\pi^2}{16} - \frac{2a\pi^2}{3} = 0$$

$$\Rightarrow \left(p - \frac{\pi}{4}\right)^2 + \frac{\pi^2(1-32a)}{48} = 0$$

$$\Rightarrow 0 \leq \frac{\pi^2(32a-1)}{48} \leq \frac{9\pi^2}{16} \Rightarrow 0 \leq (32a-1) \leq 27$$

$$\Rightarrow 1 \leq 32a \leq 28 \Rightarrow a \in \left[\frac{1}{32}, \frac{7}{8}\right]$$

16. Consider  $\tan^{-1}x = p$

$$(\tan^{-1}x) + (\cot^{-1}x) = \frac{5\pi^2}{8} \Rightarrow \left(\frac{\pi}{2}\right)^2 - 2p \left(\frac{\pi}{2} - p\right) = \frac{5\pi^2}{8}$$

$$\Rightarrow 2p^2 - p \frac{\pi}{2} - \frac{3\pi^2}{8} = 0 \Rightarrow \left(p - \frac{\pi}{4}\right)^2 - \frac{\pi^2}{16} - \frac{\pi^2}{16} = 0$$

$$\Rightarrow \left(p - \frac{\pi}{4}\right)^2 = \frac{\pi^2}{4} \Rightarrow p - \frac{\pi}{4} = \pm \frac{\pi^2}{2}$$

$$\Rightarrow \tan^{-1}x = \frac{3\pi}{4} \text{ or } -\frac{\pi}{4} \Rightarrow x = -1$$

17. Given equation ( $x, y \in -z$ );

$$\sin^{-1}\left(\frac{x}{\sqrt{1+x^2}}\right) + \cos^{-1}\left(\frac{y}{\sqrt{1+y^2}}\right) = \tan^{-1}3$$

Let  $\tan^{-1}x = \theta \in \left(-\frac{\pi}{2}, \frac{\pi}{2}\right)$  and  $\cot^{-1}y = \phi \in (0, \pi)$

$$\Rightarrow \sin^{-1}(\sin \theta) + \cos^{-1}(\cos \phi) = \tan^{-1}3x$$

$$\Rightarrow \cot^{-1}x + \cot^{-1}y = \tan^{-1}3$$

$$\Rightarrow \cot^{-1}y = \tan^{-1}3 + \tan^{-1}(-x)$$

$$\Rightarrow \cot^{-1}y = \tan^{-1}\left(\frac{3-x}{1+3x}\right)$$

$$\Rightarrow y = \frac{3x+1}{3-x} \Rightarrow xy + 3x - 3y + 1 = 0$$

$$\Rightarrow (x-3)(y+3) + 10 = 0$$

$$\Rightarrow (x-3)(y+3) = -10 \therefore x, y \in \mathbb{Z}$$

$$\begin{cases} x-3=1 & \& y+3=-10; \Rightarrow x=4, y=-13 \\ x-3=-10 & ; y+3=1; \Rightarrow x=-7, y=-2 \\ x-3=-10 & ; y+3=-1; \Rightarrow x=13, y=-4 \end{cases}$$

$$\Rightarrow \begin{cases} x-3=-1 & ; y+3=10; \Rightarrow x=2, y=7 \\ x-3=2 & ; y+3=-5; \Rightarrow x=5, y=-8 \\ x-3=-2 & ; y+3=5; \Rightarrow x=1, y=2 \\ x-3=5 & ; y+3=-2; \Rightarrow x=8, y=-5 \\ x-3=-5 & ; y+3=2; \Rightarrow x=-2, y=-1 \end{cases}$$

$$\Rightarrow (4, -13); (13, 4); (-7, -2); (2, -7); (5, -8); (8, -5); (1, 1); (-2, 1)$$

$$\Rightarrow (4, -13); (13, 4); (-7, -2); (2, -7); (5, -8); (8, -5); (1, 1); (-2, 1)$$

$$\Rightarrow (4, -13); (13, 4); (-7, -2); (2, -7); (5, -8); (8, -5); (1, 1); (-2, 1)$$

$$\Rightarrow (4, -13); (13, 4); (-7, -2); (2, -7); (5, -8); (8, -5); (1, 1); (-2, 1)$$

$$\Rightarrow (4, -13); (13, 4); (-7, -2); (2, -7); (5, -8); (8, -5); (1, 1); (-2, 1)$$

$$\Rightarrow (4, -13); (13, 4); (-7, -2); (2, -7); (5, -8); (8, -5); (1, 1); (-2, 1)$$

$$\Rightarrow (4, -13); (13, 4); (-7, -2); (2, -7); (5, -8); (8, -5); (1, 1); (-2, 1)$$

$$\Rightarrow (4, -13); (13, 4); (-7, -2); (2, -7); (5, -8); (8, -5); (1, 1); (-2, 1)$$

18. (a) R.H.S. =  $2 \tan^{-1}\left(\tan \frac{x}{2} \tan \frac{y}{2}\right) = \cos^{-1}\left(\frac{1 - \tan^2 \frac{x}{2} \tan^2 \frac{y}{2}}{1 + \tan^2 \frac{x}{2} \tan^2 \frac{y}{2}}\right)$

$$= \cos^{-1}\left(\frac{\cos^2 \frac{x}{2} \cos^2 \frac{y}{2} - \sin^2 \frac{x}{2} \sin^2 \frac{y}{2}}{\cos^2 \frac{x}{2} \cos^2 \frac{y}{2} + \sin^2 \frac{x}{2} \sin^2 \frac{y}{2}}\right)$$

$$= \cos^{-1}\left(\frac{\left(\cos \frac{x}{2} \cos \frac{y}{2} + \sin \frac{x}{2} \sin \frac{y}{2}\right)\left(\cos \frac{x}{2} \cos \frac{y}{2} - \sin \frac{x}{2} \sin \frac{y}{2}\right)}{\left(\cos \frac{x}{2} \cos \frac{y}{2} + \sin \frac{x}{2} \sin \frac{y}{2}\right)^2 - 2 \sin \frac{x}{2} \sin \frac{y}{2} \cos \frac{x}{2} \cos \frac{y}{2}}\right)$$

$$= \cos^{-1}\left(\frac{\cos\left(\frac{x-y}{2}\right)\cos\left(\frac{x+y}{2}\right)}{\cos^2 \frac{x-y}{2} - \sin x \sin y}\right)$$

$$= \cos^{-1}\left(\frac{\cos x + \cos y}{1 + \cos(x-y) - \sin x \sin y}\right)$$

$$= \cos^{-1}\left(\frac{\cos x + \cos y}{1 + \cos x \cos y}\right) = \text{L.H.S.}$$

**Aliter:** L.H.S. =  $\cos^{-1}\left(\frac{\cos x + \cos y}{1 + \cos x \cos y}\right)$   
 =  $\cos^{-1}\left(\frac{2 \cos\left(\frac{x+y}{2}\right) \cos\left(\frac{x-y}{2}\right)}{1 + \cos(x-y) - \sin x \sin y}\right)$   
 =  $\cos^{-1}\left(\frac{\cos^2 \frac{x}{2} \cdot \cos^2 \frac{y}{2} - \sin^2 \frac{x}{2} \cdot \sin^2 \frac{y}{2}}{\cos^2 \frac{x}{2} \cdot \cos^2 \frac{y}{2} + \sin^2 \frac{x}{2} \cdot \sin^2 \frac{y}{2}}\right)$   
 =  $\cos^{-1}\left(\frac{1 - \tan^2 \frac{x}{2} + \tan^2 \frac{y}{2}}{1 + \tan^2 \frac{x}{2} \tan^2 \frac{y}{2}}\right)$   
 =  $2 \tan^{-1}\left(\tan \frac{x}{2} \tan \frac{y}{2}\right) = \text{R.H.S.}$

(b) R.H.S. =  $\cos^{-1}\left(\frac{b+a \left(\frac{1 - \tan^2 \frac{x}{2}}{1 + \tan^2 \frac{x}{2}}\right)}{a+b \left(\frac{1 - \tan^2 \frac{x}{2}}{1 + \tan^2 \frac{x}{2}}\right)}\right)$   
 =  $\cos^{-1}\left(\frac{(a+b) + (b-a) \tan^2 \frac{x}{2}}{(a+b) + (a-b) \tan^2 \frac{x}{2}}\right)$   
 =  $\cos^{-1}\left(\frac{1 - \left(\sqrt{\frac{a-b}{a+b}} \tan \frac{x}{2}\right)^2}{1 + \left(\sqrt{\frac{a-b}{a+b}} \tan \frac{x}{2}\right)^2}\right)$   
 =  $2 \tan^{-1}\left(\sqrt{\frac{a-b}{a+b}} \tan \frac{x}{2}\right) = \text{L.H.S.}$

**TEXTUAL EXERCISE-4 (OBJECTIVE)**

- (b) Let  $\sin^{-1}x = \theta \in \left[-\frac{\pi}{2}, 0\right)$  as  $x \in [-1, 0)$   
 $\Rightarrow x = \sin \theta$   
 $\Rightarrow \cos^{-1}(2x^2 - 1) - 2\sin^{-1}x = \cos^{-1}(-\cos^2 \theta) - 2\theta$   
 $= \pi - \cos^{-1}(\cos 2\theta) - 2\theta = \pi - (-2\theta) - 2\theta = \pi$
- (c)  $\log_{1/2}(\sin^{-1}x) > \log_{1/2}(\cos^{-1}x)$   
 $\Rightarrow 0 < \sin^{-1}x < \cos^{-1}x \quad \because \log_{1/2}x$  is decreasing function  
 $\Rightarrow 0 < 2\sin^{-1}x < \frac{\pi}{2} \Rightarrow 0 < \sin^{-1}x < \frac{\pi}{4}$   
 i.e.,  $0 < \sin^{-1}x < \frac{\pi}{4} \Rightarrow 0 \leq x < \frac{1}{\sqrt{2}}$

- (c)  $\sin^{-1}\left(\frac{1}{\sqrt{1+\alpha}}\right) + \cos^{-1}\left(\frac{1}{\sqrt{1+\alpha}}\right) = \frac{\pi}{2}$   
 $\Rightarrow m = \pi/2$   
 $\Rightarrow \sin m = \sin \frac{\pi}{2} = 1 = \sin^2 \alpha - \tan^2 \alpha$
- (b)  $\sin^{-1}(\cos(\sin^{-1}x)) + \cos^{-1}(\sin(\cos^{-1}x)) = \sin^{-1}(\cos(\sin^{-1}x)) + \cos^{-1}\left(\sin\left(\frac{\pi}{2} - \sin^{-1}x\right)\right)$   
 $= \sin^{-1}(\cos(\sin^{-1}x)) + \cos^{-1}(\cos(\sin^{-1}x)) = \pi/2$
- (a)  $\sin^{-1}x + \sin^{-1}2x = \frac{\pi}{3} \Rightarrow \sin^{-1}(2x) = \frac{\pi}{3} - \sin^{-1}x$   
 Taking sin of both side  $\sin(\sin^{-1}2x) = \sin\left(\frac{\pi}{3} - \sin^{-1}x\right)$   
 $\Rightarrow 2x = \frac{\sqrt{3}}{2} \cos(\sin^{-1}x) - \frac{1}{2}x$   
 $\Rightarrow 5x = \begin{cases} \sqrt{3} \cos(\cos^{-1}\sqrt{1-x^2}); & \text{if } x \in [0,1] \\ \sqrt{3} \cos(-\cos^{-1}(\sqrt{1-x^2})); & \text{if } x \in [-1,0] \end{cases}$   
 $\Rightarrow 5x = \sqrt{3}\sqrt{1-x^2} \quad \{\text{Clearly } x > 0\}$   
 $\Rightarrow 25x^2 - 3 - 3x^2 \Rightarrow 28x^2 = 3$   
 $\Rightarrow x = \sqrt{\frac{3}{28}} = \frac{1}{2}\sqrt{\frac{3}{7}} \quad x = \sqrt{\frac{3}{28}} = \frac{1}{2}\sqrt{\frac{3}{7}}$
- (d)  $\sin^{-1}\frac{x}{5} + \operatorname{cosec}^{-1}\frac{5}{4} = \frac{\pi}{2}$   
 $\Rightarrow \sin^{-1}\frac{x}{5} = \frac{\pi}{2} - \operatorname{cosec}^{-1}\left(\frac{5}{4}\right)$   
 $\Rightarrow \sin^{-1}\left(\frac{x}{5}\right) = \sec^{-1}\left(\frac{5}{4}\right) \Rightarrow \sin^{-1}\left(\frac{x}{5}\right) = \cos^{-1}\left(\frac{4}{5}\right)$   
 $\Rightarrow \sin^{-1}\left(\frac{x}{5}\right) = \sin^{-1}\sqrt{1 - \frac{16}{25}} = \sin^{-1}\frac{3}{5}$   
 $\Rightarrow x = 3$
- (c)  $\sin^{-1}x + \sin^{-1}(1-x) = \cos^{-1}x$ , taking sine of both side  
 $\sin(\sin^{-1}x) \cos(\sin^{-1}(1-x)) + \cos(\sin^{-1}x) \sin(\sin^{-1}(1-x)) = \sin(\cos^{-1}x)$   
 $\Rightarrow x\sqrt{1-(1-x)^2} + \sqrt{1-x^2}(1-x) = \sqrt{1-x^2}$   
 $\Rightarrow x\sqrt{2x-x^2} + \sqrt{1-x^2} - x\sqrt{1-x^2} = \sqrt{1-x^2}$   
 $\Rightarrow x(\sqrt{2x-x^2} - \sqrt{1-x^2}) = 0$   
 $\Rightarrow$  Either  $x = 0$  or  $\sqrt{2x-x^2} = \sqrt{1-x^2}$  i.e.,  $2x = 1$   
 $\Rightarrow x = 1/2 \quad \Rightarrow x = 0, 1/2$
- (a)  $\sin^{-1}\left(\frac{1}{3}\right) + \cos^{-1}\left(\frac{1}{\sqrt{1+8}}\right)$   
 $= \sin\left(\sin^{-1}\frac{2/3}{1+1/9}\right) + \cos\left(\pm \cos^{-1}\left(\frac{1}{\sqrt{1+8}}\right)\right)$   
 $(\because 2/3 \in (-1, 1)) = \frac{2}{3} \times \frac{9}{10} + \frac{1}{3} = \frac{3}{5} + \frac{1}{3} = \frac{14}{15}$
- (b) Let  $\tan^{-1}x = \theta \in \left(-\frac{\pi}{2}, \frac{\pi}{2}\right)$  but  $x > 1$  thus  $\theta \in \left(\frac{\pi}{4}, \frac{\pi}{2}\right)$   
 $2 \tan^{-1}x - \tan^{-1}\left(\frac{2x}{1-x^2}\right) = 2\theta - \tan^{-1}(\tan^2 \theta)$   
 $= 2\theta - (-\pi + 2\theta) = \pi.$



4.114 > Trigonometry

10. (c)  $\because x > 1$  thus  $\theta = \tan^{-1} x \in \left(\frac{\pi}{4}, \frac{\pi}{2}\right)$   
 $\Rightarrow 2 \tan^{-1} x + \sin^{-1} \left(\frac{2x}{1+x^2}\right) = 2\theta + \sin^{-1}(\sin 2\theta);$   
 $2\theta \in \left(\frac{\pi}{2}, \pi\right) = 2\theta + \pi - 2\theta = \pi$

11. (b, c)  $\sin^{-1} a + \sin^{-1} b = \pi/2$   
 $\Rightarrow \sin^{-1} a = \frac{\pi}{2} - \sin^{-1} b$  or  $\sin^{-1} b = \frac{\pi}{2} - \sin^{-1} a$   
 $\Rightarrow \sin^{-1} a = \cos^{-1} b$  or  $\sin^{-1} b = \cos^{-1} a$

12. (a)  $\because \cos^{-1} x = \frac{\pi}{2} - \sin^{-1} x$   
 $\Rightarrow \cos^{-1} x = \frac{\pi}{2} - \frac{\pi}{5} = \frac{5\pi - 2\pi}{10} = \frac{3\pi}{10}$

13. (b) Given  $\sin^{-1} x + \sin^{-1} y = \frac{2\pi}{3}$   
 $\Rightarrow \frac{\pi}{2} - \cos^{-1} x + \frac{\pi}{2} - \cos^{-1} y = \frac{2\pi}{3}$   
 $\Rightarrow \pi - \frac{2\pi}{3} = \cos^{-1} x + \cos^{-1} y \Rightarrow \cos^{-1} x + \cos^{-1} y = -\frac{\pi}{3}$

14. (a)  $\sin^{-1} \left(\frac{4}{5}\right) + 2 \tan^{-1} \left(\frac{1}{3}\right) = \sin^{-1} \left(\frac{4}{5}\right) + \cos^{-1} \left(\frac{1 - \frac{1}{9}}{1 + \frac{1}{9}}\right);$   
 as  $\frac{1}{3} > 0 \Rightarrow \sin^{-1} \frac{4}{5} + \cos^{-1} \left(\frac{8}{10}\right) = \sin^{-1} \frac{4}{5} + \cos^{-1} \frac{4}{5} = \frac{\pi}{2}$

15. (a, b)  $\sin^{-1} \left(a - \frac{a^2}{3} + \frac{a^3}{9} - \dots\right) + \cos^{-1} (1 + b + b^2 + \dots) = \frac{\pi}{2}$   
 $\Rightarrow \sin^{-1} \left(\frac{a}{1 + \frac{a}{3}}\right) = \frac{\pi}{2} - \cos^{-1} \left(\frac{1}{1 - b}\right)$   
 $\Rightarrow \sin^{-1} \left(\frac{3a}{3 + a}\right) = \sin^{-1} \left(\frac{1}{1 - b}\right) \Rightarrow \frac{3a}{3 + a} = \frac{1}{1 - b}$   
 $\Rightarrow 1 - b = \frac{3 + a}{3a} \Rightarrow b = \frac{2a - 3}{3a}$   
 Clearly for  $a = -3 \Rightarrow b = 1$   
 $a = 1 \Rightarrow b = -1/3$   
 $a = 1/6 \Rightarrow b = \frac{1/3 - 3}{1/2} = \frac{-16}{3}$

16. (b) Given  $2 \cos^{-1} x = \sin^{-1} (2x\sqrt{1-x^2})$   
 Let  $\cos^{-1} x = \theta \in [0, \pi]$   
 $x = \cos \theta \Rightarrow 2\theta = \sin^{-1} (2 \cos \theta |\sin \theta|)$   
 $\Rightarrow 2\theta = \sin^{-1} (\sin 2\theta) \because \sin \theta > 0$   
 $\Rightarrow 2\theta = \sin^{-1} (\sin 2\theta)$   
 $\Rightarrow 2\theta = \begin{cases} 2\theta, & 2\theta \in \left[0, \frac{\pi}{2}\right] \\ \pi - 2\theta, & 2\theta \in \left[\frac{\pi}{2}, \frac{3\pi}{2}\right] \\ -2\pi + 2\theta, & 2\theta \in \left[\frac{3\pi}{2}, 2\pi\right] \end{cases}$

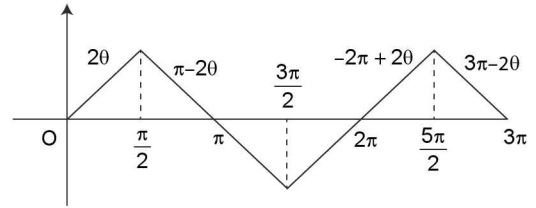

$\Rightarrow 2\theta \in \left[0, \frac{\pi}{2}\right] \Rightarrow \theta \in \left[0, \frac{\pi}{4}\right]$   
 $\Rightarrow x = \cos \theta \in \left[\frac{1}{\sqrt{2}}, 1\right]$

17. (c) Given  $\alpha \leq \sin^{-1} x + \cos^{-1} x + \tan^{-1} x \leq \beta$ . Clearly domain of function is  $[-1, 1]$

$\Rightarrow \alpha \in \frac{\pi}{2} + \tan^{-1} x \leq \beta$   
 $\because -1 \leq x \leq 1; -\frac{\pi}{4} \leq \tan^{-1} x \leq \frac{\pi}{4}$  and  $\sin^{-1} x + \cos^{-1} x = \frac{\pi}{2}$   
 Thus adding we get  $\sin^{-1} x + \cos^{-1} x + \tan^{-1} x \in \left[\frac{\pi}{4}, \frac{3\pi}{4}\right]$   
 $\Rightarrow \alpha = \frac{\pi}{4}$  and  $\beta = \frac{3\pi}{4}$

TEXTUAL EXERCISE-5 (SUBJECTIVE)

1. (a) L.H.S. =  $\tan^{-1} 1 + \tan^{-1} 2 + \tan^{-1} 3$   
 $= \pi + \tan^{-1} \left(\frac{1+2}{1-2}\right) + \tan^{-1} 3$   
 $= \pi - \tan^{-1}(3) + \tan^{-1} 3 = \pi = \text{R.H.S.}$

(b) L.H.S. =  $\tan^{-1} \left(\frac{1}{7}\right) + \tan^{-1} \left(\frac{1}{13}\right) = \tan^{-1} \left(\frac{\frac{1}{3} + \frac{1}{13}}{1 - \frac{1}{91}}\right)$   
 $\because 1/7, 1/13 > 0$  and their product  $< 1$   
 $= \tan^{-1} \left(\frac{20}{90}\right) = \tan^{-1} \frac{2}{9} = \text{R.H.S.}$

(c) L.H.S. =  $\tan^{-1} \frac{3}{4} + \tan^{-1} \frac{3}{5} - \tan^{-1} \left(\frac{8}{19}\right)$   
 $= \tan^{-1} \left(\frac{\frac{3}{4} + \frac{3}{5}}{1 - \frac{9}{20}}\right) + \tan^{-1} \left(\frac{-8}{19}\right) = \tan^{-1} \left(\frac{27}{11}\right) + \tan^{-1} \left(\frac{-8}{19}\right)$   
 $\because \left(\frac{27}{11}\right) \left(\frac{-8}{19}\right) < 0$   
 $= \tan^{-1} \left(\frac{\frac{27}{11} - \frac{8}{19}}{1 + \frac{27 \times 8}{99}}\right) = \tan^{-1} \left(\frac{513 - 88}{315}\right)$   
 $= \tan^{-1} \left(\frac{315}{315}\right) = \tan^{-1}(1) = \frac{\pi}{4}$

2. (i) L.H.S.

$$= \sin^{-1} \frac{3}{5} + \sin^{-1} \frac{8}{17} = \sin^{-1} \left( \frac{3}{5} \sqrt{1 - \frac{64}{289}} + \frac{8}{17} \sqrt{1 - \frac{9}{28}} \right)$$

$$= \sin^{-1} \left( \frac{3}{5} \times \frac{15}{17} + \frac{8}{17} \times \frac{4}{5} \right) = \sin^{-1} \left( \frac{77}{85} \right)$$

(ii)  $\sin^{-1} \frac{5}{13} + \sin^{-1} \frac{7}{25} = \sin^{-1} \left( \frac{5}{13} \sqrt{1 - \frac{49}{625}} + \frac{7}{25} \sqrt{1 - \frac{25}{169}} \right)$

$$= \sin^{-1} \left( \frac{5}{13} \times \frac{24}{25} + \frac{7}{25} \times \frac{12}{13} \right) = \sin^{-1} \left( \frac{204}{325} \right) = \cos^{-1} \left( \frac{253}{325} \right)$$

(iii) L.H.S. =  $\sin^{-1} \left( \frac{3}{5} \right) - \cos^{-1} \left( \frac{12}{13} \right) = \sin^{-1} \left( \frac{3}{5} \right) - \sin^{-1} \frac{5}{13}$

$$= \sin^{-1} \left( \frac{3}{5} \sqrt{1 - \frac{25}{169}} - \frac{5}{13} \sqrt{1 - \frac{9}{25}} \right)$$

$$= \sin^{-1} \left( \frac{3}{5} \times \frac{12}{13} - \frac{5 \times 4}{13 \times 5} \right) = \sin^{-1} \left( \frac{16}{25} \right)$$

3. (i)  $\cos^{-1} \left( \frac{4}{5} \right) + \cos^{-1} \left( \frac{12}{13} \right) = \cos^{-1} \left( \frac{4}{5} \times \frac{12}{13} - \sqrt{1 - \frac{16}{25}} \sqrt{1 - \frac{144}{169}} \right)$

$$= \cos^{-1} \left( \frac{48}{65} - \frac{3}{5} \times \frac{5}{13} \right) = \cos^{-1} \left( \frac{33}{65} \right)$$

(ii)  $\cos^{-1} \left( \frac{1}{2} \right) + \cos^{-1} \left( -\frac{1}{7} \right) = \cos^{-1} \left( \frac{-1}{14} - \sqrt{1 - \frac{1}{4}} \sqrt{1 - \frac{1}{49}} \right)$

$$= \cos^{-1} \left( \frac{-1 - \sqrt{3} \cdot 4 \sqrt{3}}{14} \right) + \cos^{-1} \left( \frac{13}{14} \right) = \cos^{-1} \left( \frac{-13}{14} \right) + \cos^{-1} \left( \frac{13}{14} \right)$$

$$= \pi - \cos^{-1} \left( \frac{13}{14} \right) + \cos^{-1} \left( \frac{13}{14} \right) = \pi$$

4. (a)  $\because T_n = \sin^{-1} \left( \frac{\sqrt{n} - \sqrt{n-1}}{\sqrt{n(n+1)}} \right)$  where  $n \in \mathbb{N}$

$$\Rightarrow T_n = \sin^{-1} \left( \frac{1}{\sqrt{n}} \sqrt{1 - \frac{1}{n+1}} - \frac{1}{\sqrt{n+1}} \sqrt{n + \frac{1}{n}} \right)$$

$$\because \left( \frac{1}{\sqrt{n}} \right)^2 + \left( \frac{1}{\sqrt{n+1}} \right)^2 < 1$$

$$\Rightarrow T_n = \sin^{-1} \frac{1}{\sqrt{n}} - \sin^{-1} \frac{1}{\sqrt{n+1}}$$

$$\Rightarrow S_n = \sum_{n=1}^n T_n = \left[ \begin{aligned} & \left( \sin^{-1} \frac{1}{1} - \sin^{-1} \frac{1}{\sqrt{2}} \right) + \\ & \left( \sin^{-1} \frac{1}{\sqrt{2}} - \sin^{-1} \frac{1}{\sqrt{3}} \right) + \\ & \left( \sin^{-1} \frac{1}{\sqrt{3}} - \sin^{-1} \frac{1}{\sqrt{4}} \right) \\ & + \dots + \left( \sin^{-1} \frac{1}{\sqrt{n}} - \sin^{-1} \frac{1}{\sqrt{n+1}} \right) \end{aligned} \right]$$

$$\Rightarrow S_n = \left( \sin^{-1} 1 - \sin^{-1} \frac{1}{\sqrt{n+1}} \right) = \frac{\pi}{2} - \sin^{-1} \left( \frac{1}{\sqrt{n+1}} \right)$$

$$\Rightarrow S_\infty = \lim_{n \rightarrow \infty} S_n = \frac{\pi}{2}$$

(b)  $T_n = \cot^{-1} \left( n^2 - \frac{3}{4} \right) = \tan^{-1} \left( \frac{4}{4n^2 - 3} \right) = \tan^{-1} \left( \frac{4}{1 + 4n^2 - 4} \right)$

$$= \tan^{-1} \left( \frac{(2n+2) - (2n-2)}{1 + (2n+2)(2n-2)} \right) = \tan^{-1}(2(n+1)) - \tan^{-1}(2(n-1))$$

$$S_n = \sum_{k=1}^n t_k = \sum_{k=1}^n \tan^{-1}(2(k+1)) - \tan^{-1}(2(k-1))$$

$$= [(\tan^{-1} 4 - \tan^{-1}(0)) + (\tan^{-1}(6) - \tan^{-1}(2)) + (\tan^{-1} 8 - \tan^{-1} 4) + (\tan^{-1} 10 + \tan^{-1} 6) + \dots + (\tan^{-1}(2(n+1)) - \tan^{-1}(2(n-1)))]$$

$$S_n = \tan^{-1}(2n) + \tan^{-1}(2n+1) - \tan^{-1} 2$$

$$\Rightarrow S_\infty = \lim_{n \rightarrow \infty} (S_n) = \frac{\pi}{2} + \frac{\pi}{2} - \tan^{-1} 2 = \pi - \tan^{-1} 2$$

5.  $\because x < 0$  does not satisfies the equation thus  $x \in \left[ 0, \frac{1}{6\sqrt{3}} \right]$

Now consider the equation  $\sin^{-1} 6\sqrt{3} = \pi/2 - \sin^{-1} 6x = \cos^{-1} 6x$

$$\Rightarrow \sin^{-1} 6\sqrt{3}x = \sin^{-1} \sqrt{1 - 36x^2}$$

$$\Rightarrow 108x^2 = 1 - 36x^2$$

$$\Rightarrow x^2 = 1/144 \quad \Rightarrow x = 1/12$$

6. (a)  $\sin^{-1}x + \sin^{-1}y + \sin^{-1}z = \pi$

$$\Rightarrow \sin^{-1}x + \sin^{-1}y = \pi - \sin^{-1}z$$

$$\Rightarrow \sin^{-1} \left( x\sqrt{1-y^2} + y\sqrt{1-x^2} \right) = \pi - \sin^{-1}z$$

Taking sine on both sides, we get

$$x\sqrt{1-y^2} + y\sqrt{1-x^2} = z$$

$$\Rightarrow x\sqrt{1-y^2} - z = -y\sqrt{1-x^2}$$

Squaring both sides, we get,  $x^2(1-y^2) + z^2 - 2zx\sqrt{1-y^2} = y^2 - x^2y^2$

$$\Rightarrow x^2 + z^2 - y^2 = 2zx\sqrt{1-y^2}$$

$$\Rightarrow x^4 + z^4 + y^2 + 2(x^2z^2 - z^2y^2 - x^2y^2) = 4z^2x^2 - 4x^2y^2z^2$$

$$\Rightarrow x^4 + y^4 + z^4 + 4x^2y^2z^2 = 2(x^2y^2 + y^2z^2 + z^2x^2)$$

(b)  $\cos^{-1}x + \cos^{-1}y = \pi - \cos^{-1}z$

$$\Rightarrow \cos^{-1} \left( xy - \sqrt{1-x^2}\sqrt{1-y^2} \right) = \pi - \cos^{-1}z$$

$$\Rightarrow xy + z = \sqrt{1-x^2}\sqrt{1-y^2}$$

$$\Rightarrow x^2y^2 + z^2 + 2xyz = (1-x^2)(1-y^2)$$

$$\Rightarrow x^2y^2 + z^2 + 2xyz = 1 - x^2 - y^2 + x^2y^2$$

$$\Rightarrow x^2y^2 + z^2 + 2xyz = 1$$

7. (a)  $\tan^{-1} \left( \frac{x+1}{x-1} \right) + \tan^{-1} \left( \frac{x-1}{x} \right) = \tan^{-1}(-7)$

Taking tangent of both side  $\frac{\frac{x+1}{x-1} + \frac{x-1}{x}}{1 - \left( \frac{x+1}{x-1} \right) \left( \frac{x-1}{x} \right)} = -7$

$$\Rightarrow \frac{2x^2 - x + 1}{x(x-1)} \left( -\frac{x}{1} \right) = -7$$

$$\Rightarrow 2x^2 - x + 1 = 7(x-1) \Rightarrow 2x^2 - 8x + 8 = 0$$

$$\Rightarrow x^2 - 4x + 4 = 0 \quad \Rightarrow (x-2)^2 = 0$$

$$\Rightarrow x = 2 \text{ is the solution.}$$

(b)  $\tan^{-1}(x-1) + \tan^{-1}(x+1) = \tan^{-1} 3x - \tan^{-1} x$

Taking tangent on both sides, we get

$$\frac{(x-1)+(x+1)}{1-(x-1)(x+1)} = \frac{3x-x}{1+3x^2}$$

$$\Rightarrow \frac{2x}{2-x^2} = \frac{2x}{1+3x^2}$$

$\Rightarrow$  Either  $x = 0$  or  $2 - x^2 = 1 + 3x^2$

$\Rightarrow x = 0$  or  $x = \pm 1/2 \Rightarrow x = 0, -1/2, 1/2$

8. Consider the series

$\operatorname{cosec}^{-1} \sqrt{10} + \operatorname{cosec}^{-1} \sqrt{50} + \operatorname{cosec}^{-1} \sqrt{170} + \dots$

$\Rightarrow T_n = \operatorname{cosec}^{-1} (\sqrt{x^2+1}\sqrt{x^2+2x+2})$

$= \sin^{-1} \left( \frac{1}{\sqrt{x^2+1}\sqrt{x^2+2x+2}} \right)$

$= \sin^{-1} \left( \frac{1}{\sqrt{(n+1)^2 - 2n}\sqrt{(n+1)^2 + 1}} \right)$

9. (a)  $S_n = \sum_{k=1}^n \tan^{-1} \left( \frac{2k}{1+(k^4+k^2+1)} \right)$

$= \sum_{k=1}^n \tan^{-1} \left( \frac{2k}{1+(k^2+k+1)(k^2-k+1)} \right)$

$= \sum_{k=1}^n \tan^{-1} \left( \frac{(k^2+k+1)-(k^2-k+1)}{1+(k^2+k+1)(k^2-k+1)} \right)$

$= \sum_{k=1}^n (\tan^{-1}(k^2+k+1) - \tan^{-1}(k^2-k+1))$

$= \{(\tan^{-1} 3 - \tan^{-1} 1) + (\tan^{-1} 7 - \tan^{-1} 3) + (\tan^{-1} 13 - \tan^{-1} 7) + \dots + (\tan^{-1}(n^2+n+1) - \tan^{-1}(n^2-n+1))\}$

$= (\tan^{-1}(n^2+n+1) - \tan^{-1} 1) = \tan^{-1} \left( \frac{n^2+n}{1+n^2+n+1} \right)$

$\Rightarrow S_n = \tan^{-1} \left( \frac{n^2+n}{n^2+n+2} \right)$

$\Rightarrow S_\infty = \lim_{n \rightarrow \infty} \tan^{-1} \left( \frac{1 + \frac{1}{n}}{1 + \frac{1}{n} + \frac{2}{n^2}} \right) = \frac{\pi}{4}$

$\Rightarrow S_n = \tan^{-1} \left( \frac{n^2+n}{n^2+n+2} \right)$  and  $S_\infty = \frac{\pi}{4}$

(b)  $S_n = \sum_{k=1}^n \tan^{-1} \left( \frac{(k+1)x - kx}{1+k(k+1)x^2} \right)$

$= \sum_{k=1}^n (\tan^{-1}(k+1)x - \tan^{-1} kx)$

$= [(\tan^{-1} 2x - \tan^{-1} x) + (\tan^{-1} 3x - \tan^{-1} 2x) + \dots + (\tan^{-1}(n+1)x - \tan^{-1} nx)] = \tan^{-1}(n+1)x - \tan^{-1} nx$

$= S_n = \tan^{-1} \left( \frac{x}{1+n(n+1)x^2} \right)$  and  $S_\infty = 0$

(c) Consider the series  $\cot^{-1} 2 + \cot^{-1} 8 + \cot^{-1} 18 + \dots + \infty$

$T_n = \cot^{-1}(2n^2) = \tan^{-1} \left( \frac{2}{1+4n^2-1} \right)$

$= \tan^{-1} \left( \frac{(2n+1)-(2n-1)}{1+(2n+1)(2n-1)} \right)$

$T_n = \tan^{-1}(2n+1) - \tan^{-1}(2n-1)$

$S_n = \sum_{n=1}^x T_n = [\tan^{-1} 3 - \tan^{-1} 1] + (\tan^{-1} 5 - \tan^{-1} 3) +$

$(\tan^{-1} 7 - \tan^{-1} 5) + \dots + (\tan^{-1}(2n+1) - \tan^{-1}(2n-1))$

$S_n = \tan^{-1}(2n+1) - \tan^{-1} 1$

$S_\infty = \frac{\pi}{2} - \frac{\pi}{4} = \frac{\pi}{4}$

$\Rightarrow S_\infty = \frac{\pi}{2}, S_n = \tan^{-1} \left( \frac{n}{n+1} \right)$

(d) Consider

$S_n = \sum_{r=1}^n \tan^{-1} \left( \frac{2^{r-1}}{1+2^{2r-1}} \right) = \sum_{r=1}^n \tan^{-1} \left( \frac{2^{r-1}(2-1)}{1+2^r \cdot 2^{r-1}} \right)$

$= \sum_{r=1}^n \tan^{-1} \left( \frac{2^r - 2^{r-1}}{1+2^r \cdot 2^{r-1}} \right) = \sum_{r=1}^n \tan^{-1}(2^r) - \tan^{-1}(2^{r-1})$

$= \tan^{-1}(2^n) - \tan^{-1}(2^0) = \tan^{-1}(2^n) - \pi/4$

$\Rightarrow S_n = \tan^{-1}(2^n) - \pi/4; S_\infty = \pi/4$

10. Consider the series  $3.4 + 8.9 + 15.16 + \dots$

$t_n = ((n+1)^2 - 1)(n+1)^2 = n(n+2)(n+1)^2 = n(n+1)(n+1)(n+2) = (n^2+n)(n^2+3n+2)$

$S_n = \sum_{n=1}^n \tan^{-1} \left( \frac{2n+2}{1+(n^2+n)(n^2+3n+2)} \right)$

$= \sum_{n=1}^n \tan^{-1}(n^2+3n+2) - \tan^{-1}(n^2+n)$

$= [(\tan^{-1} 6 - \tan^{-1} 2) + (\tan^{-1} 12) - \tan^{-1}(5) + (\tan^{-1}(20) - \tan^{-1}(12)) + \dots + \tan^{-1}(3n^2+3n+2) - \tan^{-1}(n^2+n)]$

$\Rightarrow S_n = \tan^{-1}(n^2+3n+2) - \tan^{-1} 2$

$\Rightarrow S_\infty = \frac{\pi}{2} - \tan^{-1} 2$

$\Rightarrow \cot(S_\infty) = \cot \left( \frac{\pi}{2} - \tan^{-1} 2 \right) = 2$

11. Consider the series  $\sum \left( \frac{\sec^{-1} \sqrt{|x|} + \operatorname{cosec}^{-1} \sqrt{|x|}}{\pi a} \right)^n =$

$\sum_{n=1}^{\infty} \left( \frac{\pi}{2\pi a} \right)^n = \sum_{n=1}^{\infty} \left( \frac{1}{2a} \right)^n$

Which is clearly an infinite G.P. thus to have finite value as it sum  $|CR| < 1$

$\Rightarrow \left| \frac{1}{2a} \right| < 1 \Rightarrow \frac{1}{2a} < 1$

$\Rightarrow 2a > 1 \Rightarrow a > 1/2$

$\Rightarrow a \in \left( \frac{1}{2}, \infty \right)$

12. Given  $\sin^{-1} x + \sin^{-1} y = \frac{2\pi}{3}$  ....(i)

and  $\cos^{-1} x - \cos^{-1} y = \frac{\pi}{3}$  ....(ii)

Adding both equations together, we get,  $\pi/2 + \pi/2 - 2\cos^{-1}y = \pi$

$$\Rightarrow \cos^{-1}y = 0 \quad \Rightarrow y = 1$$

Substituting in equation (ii) we get,  $\cos^{-1}x = \pi/3$

$$\Rightarrow x = \cos \pi/3 = 1/2$$

$$\Rightarrow x = 1/2, y = 1$$

$$\begin{aligned} 13. \quad \therefore & \sqrt{\frac{a(a+b+c)}{bc}} \sqrt{\frac{b(a+b+c)}{ca}} \\ &= \sqrt{\frac{(a+b+c)^2}{c^2}} = \frac{a+b+c}{c} \geq \frac{2c}{c} = 2 \end{aligned}$$

and both are positive therefore.

$$\begin{aligned} \text{L.H.S.} &= \tan^{-1} \sqrt{\frac{a(a+b+c)}{bc}} + \tan^{-1} \sqrt{\frac{b(a+b+c)}{ca}} + \\ & \quad \tan^{-1} \sqrt{\frac{c(a+b+c)}{ab}} \\ &= \pi + \tan^{-1} \left( \frac{\sqrt{\frac{a(a+b+c)}{bc}} + \sqrt{\frac{b(a+b+c)}{ca}}}{1 - \frac{a+b+c}{c}} \right) + \\ & \quad \tan^{-1} \sqrt{\frac{c(a+b+c)}{ab}} \\ &= \pi + \tan^{-1} \left( \frac{\frac{\sqrt{a+b+c}}{\sqrt{abc}}(a+b)c}{-(a+b)} \right) + \tan^{-1} \sqrt{\frac{c(a+b+c)}{ab}} \\ &= \pi - \tan^{-1} \left( \sqrt{\frac{c(a+b+c)}{ab}} \right) + \tan^{-1} \sqrt{\frac{c(a+b+c)}{ab}} \\ &= \pi = \text{R.H.S.} \end{aligned}$$

14.  $p > q > 0$  and  $pr < -1 < qr$

$$= \tan^{-1} \left( \frac{p-q}{1+pq} \right) = \tan^{-1} p - \tan^{-1} q$$

$$= \tan^{-1} \left( \frac{r-p}{1+pr} \right) = (\pi + \tan^{-1} r - \tan^{-1} p)$$

$\therefore pr < -1$  and  $p > 0, r < 0$

$$= \tan^{-1} \left( \frac{q-r}{1+qr} \right) = (\tan^{-1} q - \tan^{-1} r)$$

$$\therefore qr > -1 \text{ but } q > 0 \quad \Rightarrow \begin{cases} r < 0 \text{ or} \\ r > 0 \end{cases}$$

Thus adding all the above three we get,

$$\text{L.H.S.} = (\tan^{-1} p - \tan^{-1} q) + (\tan^{-1} q - \tan^{-1} r) + \pi + (\tan^{-1} r - \tan^{-1} p) = \pi = \text{R.H.S.}$$

15. Consider the equation

$$\sin^{-1} \sqrt{\frac{x}{x+1}} - \sin^{-1} \left( \frac{x-1}{x+1} \right) = \sin^{-1} \frac{1}{\sqrt{x+1}}$$

Clearly  $x \geq 0$  is domain restriction.

Let  $\tan^{-1} \sqrt{x} = \theta \in [0, \pi/2)$   $\sqrt{x} = \tan \theta \in [0, \infty)$

The equation reduces to

$$\sin^{-1} \sqrt{\frac{\tan^2 \theta}{\sec^2 \theta}} + \sin^{-1} \left( \frac{1 - \tan^2 \theta}{1 + \tan^2 \theta} \right) = \sin^{-1} \left( \frac{1}{\sqrt{1 + \tan^2 \theta}} \right)$$

$$\Rightarrow \sin^{-1} \sqrt{\sin^2 \theta} + \sin^{-1} \cos 2\theta = \sin^{-1} |\cos \theta|$$

$$\Rightarrow \sin^{-1}(\sin \theta) + \sin^{-1} \sin \left( \frac{\pi}{2} - 2\theta \right) = \sin^{-1} \left( \sin \left( \frac{\pi}{2} - \theta \right) \right)$$

$$\Rightarrow \theta + \frac{\pi}{2} - 2\theta = \frac{\pi}{2} - \theta$$

$$\Rightarrow \theta = \theta \text{ which is an identity for all } x \geq 0$$

$\therefore$  Set of solution is  $x \in [0, \infty)$

$$16. \quad \sin^{-1} \frac{3}{5} - \cos^{-1} \frac{12}{13} = \sin^{-1} \frac{3}{5} - \sin^{-1} \frac{5}{13}$$

$$\therefore \left( \frac{3}{5} \right)^2 + \left( \frac{5}{13} \right)^2 < 1$$

$$= \sin^{-1} \left( \frac{3}{5} \sqrt{1 - \frac{25}{169}} - \frac{5}{13} \sqrt{1 - \frac{9}{25}} \right) = \sin^{-1} \left( \frac{3}{5} \times \frac{12}{13} - \frac{5}{13} \times \frac{4}{5} \right)$$

$$= \sin^{-1} \left( \frac{36 - 20}{65} \right) = \sin^{-1} \left( \frac{16}{65} \right)$$

17. (i) Consider the equation  $2\cot^{-1} 2 - \cot^{-1} 4/5 = \operatorname{cosec}^{-1} x$

$$\Rightarrow 2 \tan^{-1} \frac{1}{2} - \cos^{-1} \frac{4}{5} = \operatorname{cosec}^{-1} x$$

$$\Rightarrow \cos^{-1} \left( \frac{1 - \frac{1}{4}}{1 + \frac{1}{4}} \right) - \cos^{-1} \frac{4}{5} = \operatorname{cosec}^{-1} x$$

$$\Rightarrow \cos^{-1} \left( \frac{3}{5} \right) - \cos^{-1} \frac{4}{5} = \operatorname{cosec}^{-1} x$$

$$\Rightarrow \cos^{-1} \left( \frac{12}{25} + \sqrt{1 - \frac{9}{25}} \sqrt{1 - \frac{16}{25}} \right) = \operatorname{cosec}^{-1} x$$

$$\Rightarrow \cos^{-1} \left( \frac{24}{25} \right) = \operatorname{cosec}^{-1} x$$

$$\Rightarrow \sin^{-1} \sqrt{1 - \left( \frac{24}{25} \right)^2} = \sin^{-1} \frac{1}{x}$$

$$\Rightarrow \sin^{-1} \frac{7}{25} = \sin^{-1} \frac{1}{x}$$

$$\Rightarrow x = \frac{25}{7}$$

(ii)  $\sin(2\cos^{-1}(\cot(2\tan^{-1}x))) = 0$

$$\Rightarrow 2\cos^{-1}(\cot(2\tan^{-1}x)) = 0, \pi \text{ or } 2\pi$$

$$\therefore \cos^{-1} x \in [0, \pi]$$

$$\Rightarrow \cos^{-1}(\cot(2\tan^{-1}x)) = 0, \pi/2, \pi$$

$$\Rightarrow \cot(2\tan^{-1}x) = 1, 0, -1$$

$$\Rightarrow 2\tan^{-1}x = \pm \pi/4, \pm \pi/2$$

$$\Rightarrow \tan^{-1}x = \pm \pi/8, \pm \pi/4$$

$$\Rightarrow x = \pm 1, 1 - \sqrt{2}, -1 - \sqrt{2}$$

$$\Rightarrow x \in \{-1, -1 - \sqrt{2}, 1, 1 + \sqrt{2}\}$$

$$(iii) 2 \tan^{-1} \frac{1}{2} + \cos^{-1} \frac{3}{5} = \operatorname{cosec}^{-1} x$$

$$\Rightarrow \cos^{-1} \left( \frac{1 - \frac{1}{4}}{1 + \frac{1}{4}} \right) + \cos^{-1} \left( \frac{3}{5} \right) = \operatorname{cosec}^{-1} x$$

$$\Rightarrow 2 \cos^{-1} \left( \frac{3}{5} \right) = \operatorname{cosec}^{-1} x$$

$$\Rightarrow \cos^{-1} \left( 2 \left( \frac{9}{25} \right) - 1 \right) = \operatorname{cosec}^{-1} x$$

$$\Rightarrow \cos^{-1} \left( -\frac{7}{25} \right) = \operatorname{cosec}^{-1} x$$

$$\Rightarrow \pi - \sin^{-1} \left( \sqrt{1 - \left( \frac{7}{25} \right)^2} \right) = \sin^{-1} \frac{1}{x}$$

$$\Rightarrow \pi - \sin^{-1} \sqrt{\frac{18 \times 32}{(25)^2}} = \sin^{-1} \frac{1}{x}$$

$$\Rightarrow \sin \left( \pi - \sin^{-1} \left( \frac{24}{25} \right) \right) = \sin^{-1} \frac{1}{x}$$

$$\Rightarrow \frac{24}{25} = \frac{1}{x} \quad \Rightarrow x = \frac{25}{24}$$

$$18. (i) \sin^2 \left( \tan^{-1} 3 - \cot^{-1} \left( -\frac{1}{2} \right) \right)$$

$$\Rightarrow \sin^2 \left( \tan^{-1} 3 + \tan^{-1} 2 - \pi \right)$$

$$\Rightarrow \sin^2 \left( \tan^{-1} 3 + \tan^{-1} 2 - \pi \right)$$

$$\Rightarrow \sin^2 \left( \pi + \tan^{-1} \left( \frac{3+2}{1-6} \right) - \pi \right)$$

$$\Rightarrow (-\sin(\tan^{-1}(-1)))^2 = \left( \sin^2 \left( -\frac{\pi}{4} \right) \right) = \frac{1}{2} = \text{R.H.S.}$$

$$(ii) \text{L.H.S.} = \sin \left( 2 \tan^{-1} \frac{1}{2} \right) + \tan \left( \frac{1}{2} \sin^{-1} \frac{15}{17} \right)$$

$$= \sin \left( \sin^{-1} \left( \frac{2 \left( \frac{1}{2} \right)}{1 + \frac{1}{4}} \right) \right) + \tan \left( \frac{\theta}{2} \right)$$

$$\text{Where } \theta = \sin^{-1} \left( \frac{15}{17} \right); \text{ where } \theta \in \left( 0, \frac{\pi}{2} \right):$$

$$\frac{15}{17} = \frac{2 \tan \frac{\theta}{2}}{1 + \tan^2 \frac{\theta}{2}} \Rightarrow \tan \frac{\theta}{2} = \frac{5}{3}, \frac{3}{5} \text{ but } \frac{\theta}{2} \in \left( 0, \frac{\pi}{4} \right)$$

$$\Rightarrow \tan \frac{\theta}{2} < 1 = \frac{4}{5} + \tan \frac{\theta}{2} = \frac{4}{5} + \frac{3}{5} = \frac{7}{5} = \text{R.H.S.}$$

$$(iii) \text{L.H.S.} = \sin \left( 2 \tan^{-1} \frac{1}{2} \right) - \tan \left( \frac{1}{2} \tan^{-1} \frac{15}{17} \right)$$

$$= \sin \left( \sin^{-1} \frac{4}{5} \right) - \tan \left( \frac{\theta}{2} \right) \text{ where } \sin \theta = \frac{15}{17} = \frac{4}{5} - \frac{3}{5} = \frac{1}{5}$$

TEXTUAL EXERCISE-5 (OBJECTIVE)

$$1. (a) \underbrace{\tan^{-1} x}_A + \underbrace{\tan^{-1} y}_B + \underbrace{\tan^{-1} z}_C = \pi \text{ then}$$

$$x = \tan A, y = \tan B, z = \tan C$$

$$\Rightarrow \tan A + \tan B + \tan C = \tan A \tan B \tan C$$

$$\Rightarrow x + y + z = xyz \quad \Rightarrow x + y + z - xyz = 0$$

$$2. (b, c) \sum_{n=1}^{\infty} \tan^{-1} \left( \frac{3}{n^2 + n - 1} \right) = \sum_{n=1}^{\infty} \tan^{-1} \left( \frac{(n+2) - (n-1)}{1 + (n+2)(n-1)} \right)$$

$$= \sum_{n=1}^{\infty} \tan^{-1}(n+2) - \tan^{-1}(n-1) \because (n+2)(n-1) > -1$$

$$= [(\tan^{-1} 3 - 0) + (\tan^{-1} 4 - \tan^{-1}) + (\tan^{-1} 5 - \tan^{-1}(2)) + (\tan^{-1} 6 - \tan^{-1} 3) + (\tan^{-1} 7 - \tan^{-1} 4) + (\tan^{-1} 8 - \tan^{-1} 5) + \dots + (\tan^{-1}(n+2) - \tan^{-1}(n-1))] = A_n \text{ as } n \rightarrow \infty$$

$$= \left( \tan^{-1} \left( \frac{3}{n^2 + n - 1} \right) - \tan^{-1} 1 - \tan^{-1} 2 \right)$$

$$= -(\tan^{-1} 1 + \tan^{-1} 2) = -\left( \frac{\pi}{4} + \tan^{-1} 2 \right)$$

$$= -\left( \pi + \tan^{-1} \left( \frac{1+2}{1-2} \right) \right) = -(\pi - \tan^{-1} 3) = \tan^{-1} 3 - \pi$$

Thus sum is either  $(\tan^{-1} 3 - \pi) - \pi/4 - \tan^{-1} 2$ .

$$3. (a) \because \left. \begin{array}{l} 1 < x < \sqrt{2} \\ 0 < x-1 < \sqrt{2}-1 \end{array} \right\}$$

$$\Rightarrow x(x-1) \in (0, 2 - \sqrt{2}) \text{ and } 2 < x+1 < \sqrt{2} + 1$$

$$\Rightarrow (x-1)(x+1) \in (0, 1) \text{ and } x(x+1) \in (2, 2 + \sqrt{2})$$

$$\text{Thus } \tan^{-1}(x-1) + \tan^{-1}(x+1) = \tan^{-1} 3x + \tan^{-1}(-x)$$

$$\Rightarrow \tan^{-1} \left( \frac{2x}{1 - (x^2 - 1)} \right) = \tan^{-1} \left( \frac{3x - x}{1 + 3x^2} \right)$$

$$\Rightarrow \frac{2x}{2 - x^2} = \frac{2x}{1 + 3x^2}$$

$$\Rightarrow \text{Either } x = 0 \text{ or } 1 = 4x^2 \text{ or } x = \pm 1/2, \text{ but } x \in (1, \sqrt{2}) \text{ therefore } x \neq 0, -1/2, 1/2, \text{ hence no solution}$$

$$4. (c) \text{ Given } \tan^{-1} x - \tan^{-1} y = \tan^{-1} A; xy > -1$$

$$\Rightarrow \tan^{-1} x + \tan^{-1}(-y) = \tan^{-1} A; x(-y) < 1$$

$$\Rightarrow \tan^{-1} \left( \frac{x-y}{1+xy} \right) = \tan^{-1} A \Rightarrow A = \frac{x-y}{1+xy}$$

$$5. (b) \text{ Given } \cos^{-1} x + \cos^{-1} y + \cos^{-1} z = \pi$$

$$\Rightarrow \cos^{-1} x + \cos^{-1} y = \pi - \cos^{-1} z$$

$$\Rightarrow \cos^{-1} \left( xy + \sqrt{1-x^2} \sqrt{1-y^2} \right) = \cos^{-1}(-z); \text{ if } x+y \geq 0; x,$$

$$y \in [-1, 1] \text{ or}$$

$$2\pi - \cos^{-1} \left( xy + \sqrt{1-x^2} \sqrt{1-y^2} \right) = \cos^{-1}(-z); \text{ if } x+y < 0,$$

$$x, y \in (-1, 1)$$

$$\Rightarrow xy + \sqrt{1-x^2} \sqrt{1-y^2} = -z$$

$$\Rightarrow xy + z = \sqrt{1-x^2} \sqrt{1-y^2}$$

$$\Rightarrow x^2 y^2 + z^2 + 2xyz = 1 - x^2 - y^2 + x^2 y^2$$

$$\Rightarrow x^2 + y^2 + z^2 + 2xyz = 1$$

6. (b) Given  $\tan^{-1} 2x + \tan^{-1} 3x = \frac{\pi}{4}$

Applying tan on both side  $\tan(\tan^{-1} 2x + \tan^{-1} 3x) = 1$

$$\Rightarrow \frac{2x+3x}{1-(2x)(3x)} = 1 \quad \Rightarrow 5x = 1 - 6x^2$$

$$\Rightarrow 6x^2 + 5x - 1 = 0$$

$$\Rightarrow 6x^2 + 6x - x - 1 = 0 \Rightarrow 6x(x+1) - (x+1) = 0$$

$$\Rightarrow (6x-1)(x+1) = 0$$

$\Rightarrow x = 1/6, -1$  but  $x = -1$  does not satisfy the equation as L.H.S. becomes negative

$$\Rightarrow x = 1/6$$

7. (b) Let  $A = \tan^{-1}x, B = \tan^{-1}y$  and  $C = \tan^{-1}z$

$$\therefore \tan^{-1}x + \tan^{-1}y + \tan^{-1}z = \pi$$

$$\Rightarrow A + B + C = \pi$$

$$\therefore \frac{1}{xy} + \frac{1}{yz} + \frac{1}{zx} = \cos A \cos B + \cos B \cos C + \cos C \cos A = 1$$

8. (d) Given  $\underbrace{\cot^{-1}x}_A + \underbrace{\cot^{-1}x}_B = \underbrace{\cot^{-1}x}_C$

$\Rightarrow$  Taking cotangent on both side, we get  $\cot(A+B) = \cot C$

$$\Rightarrow \frac{\cot A \cot B - 1}{\cos B + \cos A} = \cot C$$

$$\Rightarrow \frac{\alpha\beta - 1}{\beta + \alpha} = x$$

9. (a) Given  $\underbrace{\tan^{-1}\frac{3}{4} + \tan^{-1}\frac{3}{5}}_{x>0, y>0, xy<1} - \cot^{-1}8$

$$= \tan^{-1}\left(\frac{\frac{3}{4} + \frac{3}{5}}{1 - \frac{3}{4} \cdot \frac{3}{5}}\right) - \tan^{-1}\left(\frac{1}{8}\right)$$

$$= \tan^{-1}\left(\frac{27}{21}\right) - \tan^{-1}\left(\frac{1}{8}\right) = \underbrace{\tan^{-1}\left(\frac{9}{7}\right) + \tan^{-1}\left(-\frac{1}{8}\right)}_{x, y < 1}$$

$$= \tan^{-1}\left(\frac{\frac{9}{7} + \left(-\frac{1}{8}\right)}{1 + \frac{9}{56}}\right) = \tan^{-1}\left(\frac{65}{65}\right) = \tan^{-1}\left(\frac{115}{205}\right) = \tan^{-1}1 = \frac{\pi}{4}$$

10. (c) Given  $\sin^{-1}\frac{1}{3} + \sin^{-1}\frac{2}{3} = \sin^{-1}x$

$$\therefore \left(\frac{1}{3}\right)^2 + \left(\frac{2}{3}\right)^2 \leq 1$$

$$\Rightarrow \sin^{-1}\left(\frac{1}{3}\sqrt{1-\frac{4}{9}} + \frac{2}{3}\sqrt{1-\frac{1}{9}}\right) = \sin^{-1}x$$

$$\Rightarrow \frac{\sqrt{5}}{9} + \frac{4\sqrt{2}}{9} = x$$

$$\Rightarrow x = \frac{\sqrt{5} + 4\sqrt{2}}{9}$$

11. (d) Consider the expression

$$\tan^{-1}\left(\frac{x}{y}\right) - \tan^{-1}\left(\frac{1-y}{1+\frac{y}{x}}\right) = \tan^{-1}\frac{x}{y} - \left(\tan^{-1}1 - \tan^{-1}\frac{y}{x}\right)$$

$$= \tan^{-1}\frac{x}{y} + \tan^{-1}\frac{y}{x} - \tan^{-1}1$$

$$= \begin{cases} \tan^{-1}\frac{x}{y} + \cot^{-1}\frac{y}{x}; & xy > 0 \\ \tan^{-1}\frac{x}{y} - \pi + \cot^{-1}\frac{x}{y} - \frac{\pi}{4}; & xy < 0 \end{cases}$$

$$= \frac{\pi}{2} - \frac{\pi}{4} \text{ or } -\frac{\pi}{2} - \frac{3\pi}{4} = \frac{\pi}{4} \text{ or } -\frac{3\pi}{4}$$

12. (b)  $\cos^{-1}\frac{15}{17} + 2\tan^{-1}\frac{1}{5}$

$$= \cos^{-1}\frac{15}{17} + \cos^{-1}\left(\frac{1-\frac{1}{25}}{1+\frac{1}{25}}\right) = \cos^{-1}\left(\frac{15}{17}\right) + \cos^{-1}\left(\frac{12}{13}\right)$$

$$= \cos^{-1}\left(\frac{15 \times 12}{17 \times 13} - \sqrt{1 - \left(\frac{15}{17}\right)^2} \cdot \sqrt{1 - \left(\frac{12}{13}\right)^2}\right)$$

$$= \cos^{-1}\left(\frac{15 \times 12}{17 \times 13} - \frac{8}{17} \times \frac{5}{13}\right)$$

$$= \cos^{-1}\left(\frac{20}{17 \times 13}(9-7)\right) = \cos^{-1}\left(\frac{140}{17 \times 13}\right)$$

$$= \sin^{-1}\sqrt{\frac{(221)^2 - (40)^2}{(221)^2}} = \sin^{-1}\left(\frac{81 \times 361}{221}\right)$$

$$= \sin^{-1}\left(\frac{9 \times 19}{221}\right) = \sin^{-1}\left(\frac{171}{221}\right)$$

13. (a) Given  $\tan^{-1}x + \cos^{-1}\frac{y}{\sqrt{1+y^2}} = \sin^{-1}\left(\frac{3}{\sqrt{10}}\right)$

$$\Rightarrow \tan^{-1}x + \frac{\pi}{2} - \sin^{-1}\left(\frac{y}{\sqrt{1+y^2}}\right) = \sin^{-1}\left(\frac{3}{\sqrt{10}}\right)$$

$$\Rightarrow \tan^{-1}x + \frac{\pi}{2} - \tan^{-1}y = \sin^{-1}\left(\frac{3}{\sqrt{10}}\right)$$

$$\Rightarrow \cos^{-1}\left(\frac{3}{\sqrt{10}}\right) = \tan^{-1}y - \tan^{-1}x$$

$$\Rightarrow \tan^{-1}\frac{1}{3} = \tan^{-1}\left(\frac{y-x}{1+xy}\right)$$

$$\Rightarrow 1 + xy = 3y - 3x \Rightarrow xy + 3x - 3y - 9 = -10$$

$$\Rightarrow (x-3)(y+3) = -10$$

Clearly  $x-3 < 0$ ;  $x < 3$  and  $y+3 > 0$

$$\Rightarrow x-3 = -1; y+3 = 10$$

$$\Rightarrow x-3 = -2; y+3 = 5$$

$$\Rightarrow x = 2 \text{ and } y = 7 \text{ or } x = 1 \text{ and } y = 2$$

$$\Rightarrow (2, 7) \text{ and } (1, 2) \text{ are only two solutions.}$$

4.120 > Trigonometry

14. (b) Since  $\tan^{-1} 2$ ,  $\tan^{-1} 3$  be two angles say A and B  
 $\Rightarrow A+B = \pi + \tan^{-1} \left( \frac{2+3}{1-6} \right) = \pi + \tan^{-1} (-1) = \pi - \frac{\pi}{4} = \frac{3\pi}{4}$ .
15. (c)  $\tan^{-1} \frac{1}{3} + \tan^{-1} \frac{1}{5} + \tan^{-1} \frac{1}{7} + \tan^{-1} \frac{1}{8}$   
 $= \tan^{-1} \left( \frac{\frac{1}{3} + \frac{1}{5}}{1 - \frac{1}{15}} \right) + \tan^{-1} \left( \frac{\frac{1}{7} + \frac{1}{8}}{1 - \frac{1}{7} \times \frac{1}{8}} \right)$   
 $= \tan^{-1} \left( \frac{4}{7} \right) + \tan^{-1} \left( \frac{3}{11} \right) = \tan^{-1} \left( \frac{\frac{4}{7} + \frac{3}{11}}{1 - \frac{12}{77}} \right)$   
 $= \tan^{-1} \left( \frac{44+21}{77-12} \right) = \tan^{-1} (1) = \frac{\pi}{4}$

**SECTION-III (ONLY ONE CORRECT ANSWER)**

1. (b)  $\sin^{-1} \left( x - \frac{x^2}{2} + \frac{x^3}{4} \dots \right) + \cos^{-1} \left( x^2 - \frac{x^4}{2} + \frac{x^6}{4} \dots \right) = \frac{\pi}{2}$   
 $\Rightarrow \sin^{-1} \left[ \frac{x}{1 - (-x/2)} \right] + \cos^{-1} \left[ \frac{x^2}{1 - (-x^2/2)} \right] = \frac{\pi}{2}$   
 $\Rightarrow \sin^{-1} \left[ \frac{2x}{2+x} \right] + \cos^{-1} \left[ \frac{2x^2}{2+x^2} \right] = \frac{\pi}{2}$   
 $\Rightarrow \frac{2x}{2+x} = \frac{2x^2}{2+x^2}$   
 $\Rightarrow (2+x^2)x - (2+x)x^2 = 0$   
 $\Rightarrow x[x^2 + 2 - 2x - x^2] = 0$   
 $\Rightarrow x[2(1-x)] = 0 \Rightarrow x = 0 \text{ or } x = 1$   
 But  $0 < |x| < \sqrt{2} \Rightarrow x = 1$

2. (d)  $\operatorname{cosec}^{-1}(\cos x)$  is real if  $\cos x \in (-\infty, -1] \cup [1, \infty)$   
 $\Rightarrow \cos x = -1$  or  $1$   
 $\Rightarrow x = \text{integer multiple of } \pi$

3. (c)  $\tan \left( \frac{\pi}{4} + \frac{1}{2} \cos^{-1} x \right) + \tan \left( \frac{\pi}{4} - \frac{1}{2} \cos^{-1} x \right); x \neq 0$ .

Let  $\frac{1}{2} \cos^{-1} x = \theta \in \left[ 0, \frac{\pi}{2} \right]$

$\Rightarrow \cos^{-1} x = 2\theta \Rightarrow x = \cos 2\theta$

$\Rightarrow x = \frac{1 - \tan^2 \theta}{1 + \tan^2 \theta}$

$\therefore$  Required expression  $= \tan \left( \frac{\pi}{4} + \theta \right) + \tan \left( \frac{\pi}{4} - \theta \right)$

$= \frac{1 + \tan \theta}{1 - \tan \theta} + \frac{1 - \tan \theta}{1 + \tan \theta} = \frac{2(1 + \tan^2 \theta)}{(1 - \tan^2 \theta)} = \frac{2}{x}$

4. (a)  $x^2 - kx + \sin^{-1}(\sin 4) > 0 \forall \text{ real } x$   
 $x^2 - kx + \sin^{-1}(\sin(p+q)) > 0$  where  $4 = p+q$ ;  $q \in (q, p/2)$   
 $\Rightarrow x^2 - kx + \sin^{-1}(\sin(-q)) > 0$

$\Rightarrow x^2 - kx - q > 0 \Rightarrow x^2 - kx + p - 4 > 0$   
 $\Rightarrow \text{Disc.} < 0 \Rightarrow (-k)^2 - 4(p-4) < 0$   
 $\Rightarrow k^2 < 4(p-4) < 0$   
 Which is impossible.

5. (d)  $2(\tan^{-1} 1 + \tan^{-1} 2 + \tan^{-1} 3)$

$\therefore \tan^{-1}(x) + \tan^{-1}(y)$   
 $= \begin{cases} \tan^{-1} \left( \frac{x+y}{1-xy} \right) \text{ for } xy < 1 \\ = \pi + \tan^{-1} \left( \frac{x+y}{1-xy} \right) \text{ for } x, y > 0 \text{ and } xy > 1 \\ -\pi + \tan^{-1} \left( \frac{x+y}{1-xy} \right) \text{ for } x, y < 0 \text{ and } xy > 1 \end{cases}$

$\therefore (\tan^{-1} 1 + \tan^{-1} 2) = \pi + \tan^{-1} \left( \frac{1+2}{1-(1)(2)} \right)$

$\Rightarrow \tan^{-1} 1 + \tan^{-1} 2 = \pi - \tan^{-1} 3$   
 $\Rightarrow \tan^{-1} 1 + \tan^{-1} 2 + \tan^{-1} 3 = \pi$   
 $\Rightarrow 2(\tan^{-1} 1 + \tan^{-1} 2 + \tan^{-1} 3) = 2\pi$

6. (b) Let  $E = \tan^{-1} \frac{a}{b} - \tan^{-1} \left( \frac{a-b}{a+b} \right)$

$= \tan^{-1} \left( \frac{a}{b} \right) + \tan^{-1} \left( \frac{b-a}{b+a} \right)$

Now,  $\left( \frac{a}{b} \right) \left( \frac{b-a}{b+a} \right) < 1 \Rightarrow \frac{a(b-a)}{b(b+a)} - 1 < 0$

$\Rightarrow \frac{ab - a^2 - b^2 - ab}{b(a+b)} < 0 \Rightarrow \frac{-(a^2 - b^2)}{b(a+b)} < 0$

$\Rightarrow b(a+b) > 0$

$\Rightarrow b < 0; a+b < 0$  and  $b > 0; a+b > 0$

$\Rightarrow b < 0; a < -b$  and  $b > 0; -a < b$

$\Rightarrow b < 0; a < |b|$  and  $b > 0; -a < |b|$

$\Rightarrow |a| < |b|$  which is given

$\therefore \tan^{-1} \left( \frac{a}{b} \right) + \tan^{-1} \left( \frac{b-a}{b+a} \right) = \tan^{-1} \left( \frac{\frac{a}{b} + \frac{b-a}{b+a}}{1 - \frac{a}{b} \times \frac{(b-a)}{b+a}} \right)$

$= \tan^{-1} \left[ \frac{ab + a^2 + b^2 - ab}{b^2 + ab - ab + a^2} \right] = \frac{\pi}{4}$

7. (b)  $2 \tan^{-1}(\cos x) = \tan^{-1}(2 \operatorname{cosec} x)$

L.H.S.  $= 2 \tan^{-1}(\cos x) = \tan^{-1} \left( \frac{2 \cos x}{1 - \cos^2 x} \right)$  for  $\cos x \neq \pm 1$

R.H.S.  $= \tan^{-1}(2 \operatorname{cosec} x) \Rightarrow \frac{2 \cos x}{1 - \cos^2 x} = 2 \operatorname{cosec} x$

$\Rightarrow \cos^2 x + \sin x \cos x - 1 = 0$

$\Rightarrow \sin x \cos x - \sin^2 x = 0$

$\Rightarrow \sin x (\cos x - \sin x) = 0$

$\Rightarrow \sin x = 0$  or  $\sin x = \cos x$

$\Rightarrow \cos x = \pm 1$  or  $\tan x = 1$ , but  $\cos x \neq \pm 1$

$\Rightarrow \tan x = 1 \Rightarrow x = \left( n\pi + \frac{\pi}{4} \right)$

Or  $\cos x = \pm 1; x = n\pi$

L.H.S.  $= \pm \pi/2$ , but R.H.S. is not defined for  $x = n\pi$

8. (b)  $f(x) = \sin^{-1} \left\{ \frac{\sqrt{3}}{2}x - \frac{1}{2}\sqrt{1-x^2} \right\}; -\frac{7}{2} \leq x \leq 1$ , for  $f(x)$  to

be defined,  $x \in [-1, 1]$ , so let  $\cos\theta = x$  and  $\theta \in [0, \pi]$

$\Rightarrow \sin\theta = \sqrt{1-x^2}$

$\therefore f(x) = \sin^{-1} \left\{ \sin \frac{\pi}{3} \cos\theta - \cos \frac{\pi}{3} \sin\theta \right\}$   
 $= \sin^{-1} \left\{ \sin \left( \frac{\pi}{3} - \theta \right) \right\}$  .....(i)

Now for

$\theta \in \left[ 0, \frac{5\pi}{6} \right]; -\theta \in \left[ -\frac{5\pi}{6}, 0 \right]$  and  $\frac{\pi}{3} - \theta \in \left[ -\frac{\pi}{2}, \frac{\pi}{3} \right]$

$\Rightarrow \sin^{-1} \left( \sin \left( \frac{\pi}{3} - \theta \right) \right) = \frac{\pi}{3} - \theta = \frac{\pi}{3} - \cos^{-1} x = \sin^{-1} x - \frac{\pi}{6}$

And for

$\theta \in \left( \frac{5\pi}{6}, \pi \right]; -\theta \in \left[ -\pi, -\frac{5\pi}{6} \right]$  and  $\frac{\pi}{3} - \theta \in \left[ -\frac{2\pi}{3}, -\frac{\pi}{2} \right]$

$\Rightarrow f(x) = - \left( \frac{\pi}{3} - \theta \right) - \pi = -\frac{4\pi}{3} + \theta = -\frac{4\pi}{3} + \cos^{-1} x$   
 $= \frac{\pi}{2} - \sin^{-1} x - \frac{4\pi}{3} = \frac{-5\pi}{6} - \sin^{-1} x$

9. (a)  $\sin^{-1} \left[ \cos \left( \sin^{-1} \sqrt{\frac{2-\sqrt{3}}{4}} + \cos^{-1} \frac{\sqrt{12}}{4} + \sec^{-1} \sqrt{2} \right) \right]$

$= \sin^{-1} \left[ \cos \left\{ \sin^{-1} \sqrt{\frac{2-\sqrt{3}}{4}} + \frac{\pi}{6} + \frac{\pi}{4} \right\} \right]$

$= \sin^{-1} \left[ \cos \left\{ \sin^{-1} \sqrt{\frac{2-\sqrt{3}}{4}} + \frac{5\pi}{12} \right\} \right]$

$= \sin^{-1} \left[ \cos \left\{ \sin^{-1} \left( \frac{\sqrt{3}}{2} \cdot \frac{1}{\sqrt{2}} - \frac{1}{2} \cdot \frac{1}{\sqrt{2}} \right) + \frac{5\pi}{12} \right\} \right]$

$= \sin^{-1} \left[ \cos \left\{ \sin^{-1} \left( \sin \left( \frac{\pi}{3} - \frac{\pi}{4} \right) \right) + \frac{5\pi}{12} \right\} \right]$

$= \sin^{-1} \left[ \cos \left\{ \frac{\pi}{12} + \frac{5\pi}{12} \right\} \right] = 0$

10. (b)  $(\sec^{-1}x)^2 + (\operatorname{cosec}^{-1}x)^2 = (\sec^{-1}x)^2 + \left( \frac{\pi}{2} - \sec^{-1}x \right)^2$

$= 2(\sec^{-1}x)^2 - \pi \sec^{-1}x + \frac{\pi^2}{4}$

$= 2 \left[ (\sec^{-1}x)^2 - \frac{\pi}{2} \sec^{-1}x + \frac{\pi^2}{16} \right] + \frac{\pi^2}{8}$

$= 2 \left( \sec^{-1}x - \frac{\pi}{4} \right)^2 + \frac{\pi^2}{8}$

Now  $\sec^{-1}x \in [0, \pi] \sim \left\{ \frac{\pi}{2} \right\}$

$\Rightarrow \left( \sec^{-1}x - \frac{\pi}{4} \right) \in \left[ \frac{-\pi}{4}, \frac{3\pi}{4} \right] \sim \left\{ \frac{\pi}{4} \right\}$

$\Rightarrow \left( \sec^{-1}x - \frac{\pi}{4} \right)^2 \in \left[ 0, \frac{9\pi^2}{16} \right] \sim \left\{ \frac{\pi^2}{16} \right\}$

$\Rightarrow 2 \left( \sec^{-1}x - \frac{\pi}{4} \right)^2 + \frac{\pi^2}{8} \in \left[ \frac{\pi^2}{8}, \frac{5\pi^2}{4} \right] \sim \left\{ \frac{\pi^2}{4} \right\}$

$\Rightarrow \text{Maximum value} = \frac{5\pi^2}{4}$

11. (b)  $[\sin^{-1} \cos^{-1} \sin^{-1} \tan^{-1}x] = 1$ ;  $[\cdot]$  is gint function

$\Rightarrow 1 \leq \sin^{-1} \cos^{-1} \sin^{-1} \tan^{-1}x < 2$ , but maximum value  $\sin^{-1}x = \frac{\pi}{2} < 2$

$\Rightarrow 1 \leq \sin^{-1} \cos^{-1} \sin^{-1} \tan^{-1}x \leq \pi/2$

$\Rightarrow \sin 1 \leq \cos^{-1} \sin^{-1} \tan^{-1}x \leq 1$

( $\because \sin\theta$  is increasing on  $[-\pi/2, \pi/2]$ )

$\Rightarrow \cos(\sin 1) \geq \sin^{-1} \tan^{-1}x \geq \cos 1$

( $\because \cos\theta$  is decreasing on  $[0, \pi]$ )

$\Rightarrow \sin \cos \sin 1 \geq \tan^{-1}x \geq \sin \cos 1$

( $\because \sin\theta$  is increasing on  $[0, \pi/2]$ )

$\Rightarrow \tan \sin \cos \sin 1 \geq x \geq \tan \sin \cos 1$

( $\because \tan\theta$  is increasing on  $[0, \pi/2]$ )

$\therefore x \in [\tan \sin \cos 1, \tan \sin \cos \sin 1]$

12. (a) Given equation is  $\sin^{-1}x + \sin^{-1}(1-x^2) = \cos^{-1}x + \cos^{-1}(1-x^2)$

$\Rightarrow \sin^{-1}x + \sin^{-1}(1-x^2) = \pi/2 - \sin^{-1}x + \pi/2 - \sin^{-1}(1-x^2)$

$\Rightarrow 2[\sin^{-1}x + \sin^{-1}(1-x^2)] = \pi$

$\Rightarrow \sin^{-1}x + \sin^{-1}(1-x^2) = \pi/2$

$\Rightarrow \sin^{-1}x = \cos^{-1}(1-x^2)$

$\Rightarrow \sin^{-1}x$  and  $\cos^{-1}(1-x^2) \in [0, \pi/2]$

$\Rightarrow x \geq 0$

$\Rightarrow \cos^{-1} \sqrt{1-x^2} = \cos^{-1}(1-x^2)$

$\Rightarrow \sqrt{1-x^2} = 1-x^2 \Rightarrow (1-x^2)^2 - (1-x^2) = 0$

$\Rightarrow (1-x^2)^2 - [(1-x^2)-1] = 0$

$\Rightarrow (1-x^2) - (-x^2) = 0$

$\Rightarrow x = 0$  or  $x = \pm 1$  (But  $x \geq 0$ )

$\therefore$  There are 2 solution i.e.,  $x = 0$  and  $x = 1$

13. (c)  $\tan^{-1}x + \tan^{-1}y + \tan^{-1}z = \pi$  or  $\pi/2$

$\Rightarrow \tan^{-1}x + \tan^{-1}y = (\pi - \tan^{-1}z)$

If sum is  $\pi$  also in this case each of  $x, y, z$  will be non-negative.

$\Rightarrow \tan^{-1} \left[ \frac{x+y}{1-xy} \right] = \pi - \tan^{-1}z$  for  $x, y, z > 0$

or  $\pi + \tan^{-1} \left( \frac{x+y}{1-xy} \right) = \pi - \tan^{-1}z$  for  $z, y, z > 0; xy < 1$

$\Rightarrow \frac{x+y}{1-xy} = -z$  for  $x, y, z \geq 0; xy < 1$

or  $\tan^{-1} \left( \frac{x+y}{1-xy} \right) = -\tan^{-1}z$  for  $x, y, z \geq 0; xy < 1$

$\Rightarrow \frac{x+y}{1-xy} = -z$  for  $x, y, z \geq 0$



4.122 > Trigonometry

$$\Rightarrow x + y + z = xyz$$

Also for  $\tan^{-1} + \tan^{-1}y + \tan^{-1}z = \pi/2$

$\Rightarrow$  (Either all  $x, y, z$  are non-negative or at most one is negative)

$$\Rightarrow \tan^{-1}x + \tan^{-1}y = \cot^{-1}z$$

$$\Rightarrow \tan^{-1}\left(\frac{x+y}{1-xy}\right) = \cot^{-1}z \text{ for } xy < 1$$

or  $\pi + \tan^{-1}\left(\frac{x+y}{1-xy}\right) = \cot^{-1}z \text{ for } xy > 1$

$$\Rightarrow \tan^{-1}\left(\frac{x+y}{1-xy}\right) = \begin{cases} \tan^{-1}\left(\frac{1}{z}\right) & \text{for } z > 0; \text{ for } xy < 1 \\ \pi + \tan^{-1}\left(\frac{1}{z}\right) & \text{for } z < 0; \text{ for } xy < 1 \end{cases}$$

or  $\pi + \tan^{-1}\left(\frac{x+y}{1-xy}\right) = \begin{cases} \tan\left(\frac{1}{z}\right) & \text{for } z > 0; \text{ for } xy > 1 \\ \pi + \tan^{-1}\left(\frac{1}{z}\right) & \text{for } z < 0; \text{ for } xy > 1 \end{cases}$

$$\Rightarrow \frac{x+y}{1-xy} = \frac{1}{z} \text{ for } xy < 1 \text{ or } xy > 1$$

$$\Rightarrow xz + yz = 1 - xy \Rightarrow xy + yz + zx = 1$$

14. (a)  $\cot^{-1}\left(\frac{xy+1}{x-y}\right) + \cot^{-1}\left(\frac{yz+1}{y-z}\right) + \cot^{-1}\left(\frac{zx+1}{z-x}\right);$

$x > y > z > 0$  and  $x, y, z$  distinct

$$= \tan^{-1}\left(\frac{x-y}{1+xy}\right) + \tan^{-1}\left(\frac{y-z}{1+yz}\right) + \tan^{-1}\left(\frac{z-x}{1+zx}\right)$$

$$= (\tan^{-1}x - \tan^{-1}y) + (\tan^{-1}y - \tan^{-1}z) + (\tan^{-1}z - \tan^{-1}x) = 0$$

15. (c) If  $\tan^{-1}\left(\frac{a+x}{a}\right) + \tan^{-1}\left(\frac{a-x}{a}\right) = \frac{\pi}{6}$

For  $x = 0$ , L.H.S. =  $\tan^{-1}1 + \tan^{-1}1 = \pi/2 \neq$  R.H.S.

So,  $x \neq 0$ , Now  $\left(\frac{a+x}{a}\right)\left(\frac{a-x}{a}\right) = \frac{a^2-x^2}{a^2} = 1 - \frac{x^2}{a^2} < 1$

$$\therefore \tan^{-1}\left(\frac{a+x}{a}\right) + \tan^{-1}\left(\frac{a-x}{a}\right)$$

$$= \tan^{-1}\left[\frac{\frac{a+x}{a} + \frac{a-x}{a}}{1 - \left(\frac{a^2-x^2}{a^2}\right)}\right] = \tan^{-1}\left[\frac{2}{\frac{x^2}{a^2}}\right]$$

$$\therefore \tan^{-1}\left[\frac{2a^2}{x^2}\right] = \frac{\pi}{6}$$

$$\Rightarrow \frac{2a^2}{x^2} = \frac{1}{\sqrt{3}} \Rightarrow x^2 = 2a^2\sqrt{3}$$

16. (c)  $\tan^{-1}\frac{c_1x-y}{c_1y+x} + \tan^{-1}\left(\frac{c_2-c_1}{1+c_2c_1}\right) + \tan^{-1}\left(\frac{c_3-c_2}{1+c_3c_2}\right)$

$$+ \dots + \tan^{-1}\left(\frac{c_n-c_{n-1}}{1+c_n c_{n-1}}\right) = 0$$

$$\Rightarrow \tan^{-1}\left(\frac{c_1-y/x}{1+c_1 y/x}\right) + \tan^{-1}c_2 - \tan^{-1}c_1 + \tan^{-1}c_3 - \tan^{-1}c_2$$

$$+ \dots + \tan^{-1}c_n - \tan^{-1}c_{n-1} = 0$$

$$\Rightarrow \tan^{-1}c_n - \tan^{-1}\frac{y}{x} = 0 \Rightarrow \tan^{-1}c_n = \tan^{-1}y/x$$

$$\Rightarrow \tan^{-1}1/c_n = \tan^{-1}\frac{x}{y}$$

17. (c)  $\sqrt{1+\cos 2x} = \sqrt{2} \sin^{-1}(\sin x); -\pi \leq x \leq \pi$

$$\Rightarrow \sqrt{2}|\cos x| = \sqrt{2} \sin^{-1}(\sin x)$$

$$\Rightarrow |\cos x| = \sin^{-1}(\sin x); -\pi \leq x \leq \pi$$

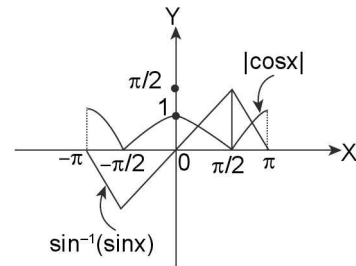

$\therefore$  There are exactly two solutions

18. (c)  $|y| = \sin x, y = \cos^{-1}(\cos x); 2\pi \leq x \leq 2\pi$

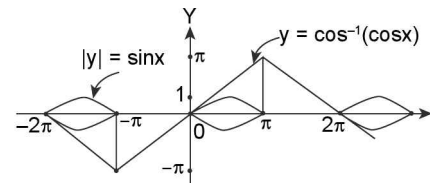

There are exactly three solution in  $[-2\pi, 2\pi]$

19. (a)  $\sum_{r=0}^{\infty} \tan^{-1}\left(\frac{1}{1+r+r^2}\right) = \sum_{r=0}^{\infty} \tan^{-1}\left[\frac{(r-1)-r}{1+r(r+1)}\right]$

$$= \sum_{r=0}^{\infty} (\tan^{-1}(r+1) - \tan^{-1}r) = \lim_{x \rightarrow \infty} \sum_{r=0}^n \tan^{-1}(r+1) - \tan^{-1}r$$

$$= \lim_{x \rightarrow \infty} \{(\tan^{-1}1 - \tan^{-1}0) + (\tan^{-1}2 - \tan^{-1}1) + (\tan^{-1}3 - \tan^{-1}2) + \dots + (\tan^{-1}(n+1) - \tan^{-1}n)\}$$

$$= \lim_{x \rightarrow \infty} [\tan^{-1}(n+1)] = \frac{\pi}{2}$$

20. (c)  $\cos^{-1}\left(\frac{1}{2}x^2 + \sqrt{1-x^2}\sqrt{1-\frac{x^2}{4}}\right) = \cos^{-1}\frac{x}{2} - \cos^{-1}x \dots (i)$

$$\cos^{-1}x - \cos^{-1}y = \begin{cases} \cos^{-1}(xy + \sqrt{1-x^2}\sqrt{1-y^2}); & x \leq y, xy \in [-1, 1] \\ -\cos^{-1}(xy + \sqrt{1-x^2}\sqrt{1-y^2}); & x \geq y, xy \in [-1, 1] \end{cases}$$

$\therefore$  is true for  $\frac{x}{2} \leq x$  i.e., for  $x \geq 0$  and  $x \leq 1$

$\therefore x \in [0, 1]$

21. (a)  $\cos^{-1} x + (\sin^{-1} y)^2 = \frac{\pi}{4}$  .....(i)

and  $(\sin^{-1} y)^2 - (\cos^{-1} x) = \frac{\pi^2}{16}$  ....(ii)

Adding (i) and (ii) we get,  $2(\sin^{-1} y)^2 = \frac{\pi^2}{4} \left( n + \frac{1}{4} \right)$

$\Rightarrow (\sin^{-1} y)^2 = \frac{\pi^2}{8} \left( n + \frac{1}{4} \right)$

L.H.S.  $\in \left[ 0, \frac{\pi^2}{4} \right] \Rightarrow 0 \leq \frac{\pi^2}{8} \left( n + \frac{1}{4} \right) \leq \frac{\pi^2}{4}$

$\Rightarrow 0 \leq \left( n + \frac{1}{4} \right) \leq 2$

$\Rightarrow n = 0, 1$

$\Rightarrow$  Only positive integer value of  $n = 1$

22. (a)  $\sin^{-1} \left( \frac{1}{\sqrt{r+1}} \right) - \sin^{-1} \left( \frac{1}{\sqrt{r}} \right); r \geq 1$

$= \tan^{-1} \left( \frac{1}{\sqrt{r}} \right) - \tan^{-1} \left( \frac{1}{\sqrt{r-1}} \right)$

$\therefore \sum_{r=1}^n \left\{ \sin^{-1} \left( \frac{1}{\sqrt{r+1}} \right) - \sin^{-1} \left( \frac{1}{\sqrt{r}} \right) \right\}$

$= \sum_{r=1}^n \tan^{-1} \left( \frac{1}{\sqrt{r}} \right) - \tan^{-1} \left( \frac{1}{\sqrt{r+1}} \right)$

$= \lim_{x \rightarrow \infty} \left[ \tan^{-1} \left( \frac{1}{\sqrt{1}} \right) - \tan^{-1} \left( \frac{1}{\sqrt{0}} \right) + \tan^{-1} \left( \frac{1}{\sqrt{2}} \right) - \tan^{-1} \left( \frac{1}{\sqrt{1}} \right) \right]$

$+ \tan^{-1} \left( \frac{1}{\sqrt{3}} \right) - \tan^{-1} \left( \frac{1}{\sqrt{2}} \right) + \dots + \tan^{-1} \left( \frac{1}{\sqrt{n}} \right) - \tan^{-1} \left( \frac{1}{\sqrt{n+1}} \right)$

$= \tan^{-1} \frac{1}{\sqrt{n}} - \frac{\pi}{2}$

23. (a)  $[\cot^{-1}x]^2 - 6[\cot^{-1}x] + 9 \leq 0; [.]$  is greatest integer function.

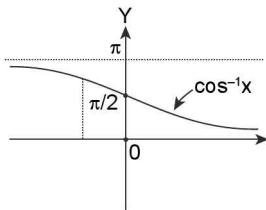

$\Rightarrow ([\cot^{-1}x] - 3)^2 \leq 0$

$\Rightarrow [\cot^{-1}x] = 3$

$\Rightarrow 3 \leq \cot^{-1} x < 4$

$\Rightarrow 3 \leq \cot^{-1} x \leq p$

$\Rightarrow -\infty < x \leq \cot 3$

24. (d) Given  $[\sin^{-1}x] + [\cos^{-1}x] = 0$  .....(i)

$\therefore x$  is a non-negative real number

$\Rightarrow \sin^{-1} x \in [0, \pi/2]$  and  $\cos^{-1} x \in [0, \pi/2]$

$\Rightarrow [\sin^{-1}x], [\cos^{-1}x] \in \{0, 1\}$

$\therefore$  Equation (i) holds when  $[\sin^{-1}x] = [\cos^{-1}x] = 0$

$\Rightarrow 0 \leq \sin^{-1}x < 1$  and  $0 \leq \cos^{-1}x < 1$

$\Rightarrow 0 \leq x < \sin^{-1}x < 1$  and  $\cos 1 < \cos^{-1}x \leq 1$

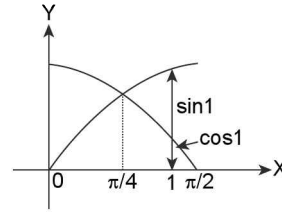

Clearly  $\sin 1 > \cos 1$

$\therefore x \in (\cos 1, \sin 1)$

25. (d)  $[\tan^{-1}x] + [\cot^{-1}x] = 2; [.]$  is greatest integer function

$\therefore [\tan^{-1}x] \in \{-2, -1, 0, 1\}$  and  $[\cot^{-1}x] \in \{0, 1, 2, 3\}$

$\Rightarrow$  Given equation is satisfied for

$\begin{cases} [\tan^{-1}x] = -1; [\cot^{-1}x] = 3 \\ [\tan^{-1}x] = 0; [\cot^{-1}x] = 2 \text{ or} \\ [\tan^{-1}x] = 1; [\cot^{-1}x] = 1 \end{cases}$

$\Rightarrow \begin{cases} \tan^{-1}x \in [-1, 0) \text{ and } \cot^{-1}x \in [3, \pi) \\ \tan^{-1}x \in [0, 1); \cot^{-1}x \in [2, 3) \text{ (impossible as } x \geq 0 \Rightarrow \cot^{-1}x > \pi/2) \\ \tan^{-1}x \in [1, 2); \cot^{-1}x \in [1, 2) \end{cases}$

$\Rightarrow x \in [-\tan 1, 0]$  and  $x \in (-\infty, \cot 3]$  or  $\tan^{-1}x \in$

$\left[ 1, \frac{\pi}{2} \right); \tan^{-1} \frac{1}{x} \in [1, 2)$  i.e.,  $\tan^{-1}x, \tan^{-1} \frac{1}{x} \in \left[ 1, \frac{\pi}{2} \right)$

i.e.,  $x \in [\tan 1, \infty)$  and  $\frac{1}{x} \in [\tan 1, \infty)$  (impossible)

$\therefore x \in [-\tan 1, 0)$  and  $x \in (-\infty, \cot 3]$  is the only possibility

$\Rightarrow x \in \emptyset$  (No solution)

26 (b)  $\sin^{-1}(\cos(\sin^{-1}x)) + \cos^{-1}(\sin(\cos^{-1}x))$

$= \sin^{-1} \left( \sin \left( \frac{\pi}{2} - \sin^{-1}x \right) \right) + \cos^{-1}(\sin(\cos^{-1}x))$

$= \sin^{-1}(\sin(\cos^{-1}x)) + \cos^{-1}(\sin(\cos^{-1}x)) = p/2$

27. (b)  $\tan^{-1} \left( \frac{xy}{zr} \right) + \tan^{-1} \left( \frac{yz}{xr} \right) + \tan^{-1} \left( \frac{zx}{yr} \right)$

$= \tan^{-1} \left[ \frac{\frac{xy}{zr} + \frac{yz}{xr}}{1 - \frac{xy}{zr} \cdot \frac{yz}{xr}} \right] + \tan^{-1} \left[ \frac{zx}{yr} \right]$

$= \tan^{-1} \left[ \frac{\frac{y}{r} \left( \frac{x}{z} + \frac{z}{x} \right)}{1 - \frac{y^2}{r^2}} \right] + \tan^{-1} \left( \frac{zx}{yr} \right)$

$= \tan^{-1} \left[ \frac{\frac{y}{r} \left( \frac{x^2 + z^2}{zx} \right)}{\frac{r^2 - y^2}{r^2}} \right] + \tan^{-1} \left( \frac{zx}{yr} \right)$

4.124 > Trigonometry

$$= \tan^{-1} \left[ \frac{y}{r} \cdot \frac{(r^2 - y^2)}{zx} \times \frac{r^2}{(r^2 - y^2)} \right] + \tan^{-1} \left( \frac{zx}{yr} \right)$$

$$= \tan^{-1} \left[ \frac{ry}{zx} \right] + \tan^{-1} \left[ \frac{zx}{ry} \right] = \tan^{-1} \left( \frac{ry}{zx} \right) + \cot^{-1} \left( \frac{ry}{zx} \right) = \frac{\pi}{2}$$

28. (a)  $\sin^{-1}a + \sin^{-1}b + \sin^{-1}c = p$   
 $\Rightarrow$  Each of a, b, c should be non negative as otherwise sum  $\neq p$   
 $\therefore a\sqrt{1-a^2} + b\sqrt{1-b^2} + c\sqrt{1-c^2}$

Let  $\sin^{-1}a = q \Rightarrow a = \sin q; \cos \theta = \sqrt{1-a^2}$

Let  $\sin^{-1}b = f$

$\Rightarrow b = \sin f; \cos \phi = \sqrt{1-b^2}$  and  $\sin^{-1}c = y$

$\Rightarrow c = \sin y; \cos \psi = \sqrt{1-c^2}$

$\therefore q + f + y = p$

Now,  $\sin q \cos q + \sin f \cos f + \sin y \cos y$

$$= \frac{1}{2}(\sin 2\theta + \sin 2\phi + \sin 2\psi)$$

$$= \frac{1}{2}[2\sin(\theta + \phi) \cdot \cos(\theta - \phi) + 2\sin \psi \cos \psi]$$

$$= \frac{1}{2}[2\sin \psi [\cos(\theta - \phi) - \cos(\theta + \phi)]]$$

$$= \frac{1}{2}[2\sin \psi (2\sin \theta \sin \phi)] = 2\sin \theta \sin \phi \sin \psi = 2abc$$

29. (a)  $\cos^{-1} \frac{a-x}{a-b} = \sin^{-1} \frac{x-b}{a-b}$

$\therefore$  For permissible values of  $\sqrt{\frac{a-x}{a-b}}$ ;

$$\cos^{-1} \frac{a-x}{a-b} = \sin^{-1} \left( \sqrt{1 - \left( \frac{a-x}{a-b} \right)^2} \right) = \sin^{-1} \frac{x-b}{a-b}$$

$$\Rightarrow 1 \geq \frac{a-x}{a-b} \geq 0$$

$$\Rightarrow (a-x)(a-b) \geq 0; a \neq b \text{ and } (b-x)(a-b) \leq 0; a \neq b$$

**Case (i):** For  $a > b$

$$a-x \geq 0 \text{ and } b-x \leq 0$$

i.e.,  $b \leq x \leq a$

**Case (ii):** For  $a < b$

$$a-x \geq 0 \text{ and } b-x \geq 0$$

$$x \leq a \text{ and } x \leq b$$

$$\therefore x \leq a < b$$

30. (c)  $x_1 + x_2 = 2 \tan^{-1} \left( \frac{1+x}{1-x} \right) + \sin^{-1} \left( \frac{1-x^2}{1+x^2} \right); x \in (0,1)$

$$= 2 \tan^{-1} \left( \tan \left( \frac{\pi}{4} + \theta \right) \right) \frac{\pi}{2} - \cos^{-1}(\cos 2\theta); \text{ where } \theta = \tan^{-1} x$$

Also  $\theta = \tan^{-1} x$  and  $x \in (0,1) \Rightarrow \theta \in (0, \pi/4)$

$$\Rightarrow \frac{\pi}{4} + \theta \in \left( \frac{\pi}{4}, \frac{\pi}{2} \right) \text{ and } 2\theta \in (0, \pi/2)$$

$$\therefore x_1 + x_2 = 2 \left( \frac{\pi}{4} + \theta \right) + \frac{\pi}{2} - 2\theta = \pi$$

31. (c) For  $\alpha \in \left( -\frac{3\pi}{2}, -\pi \right)$ ,  $\tan \alpha < 0$

$$\Rightarrow \tan^{-1}(\cot \alpha) - \cot^{-1}(\tan \alpha) = -\pi$$

Also for points in 2<sup>nd</sup> quadrant

$$\sin^{-1}(\sin \alpha) + \cos^{-1}(\cos \alpha) = \pi.$$

32. (d)  $xy > 0 \Rightarrow x$  &  $y$  are of same sign

$$x + \frac{1}{x} \geq 2 \text{ or } \leq -2$$

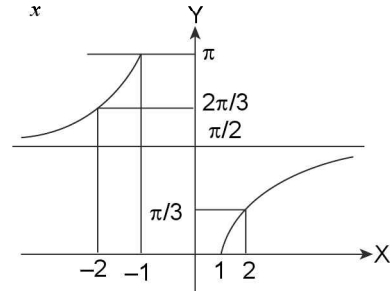

$$\sec^{-1} \left( x + \frac{1}{x} \right) \in \left[ \frac{\pi}{3}, \frac{\pi}{2} \right) \cup \left( \frac{\pi}{2}, \frac{2\pi}{3} \right]$$

$$\therefore z \in \left[ \frac{2\pi}{3}, \pi \right) \cup \left( \pi, \frac{4\pi}{3} \right]$$

Hence, value of  $z$  (among the given) which does not lie in the set is  $\frac{5\pi}{3}$ .

33. (b) Let  $f(x) = \pi \cot^{-1}(x-1) + (\pi-1) \cot^{-1} x$

$$f'(x) = \frac{-\pi}{(x-1)^2+1} - \frac{(\pi-1)}{x^2+1} < 0 \forall x \in \mathbb{R}$$

Hence  $f(x)$  is decreasing function

$$\text{and } 0 < f(x) < \pi (2\pi - 1)$$

$$\therefore f(x) = 2\pi - 1 \text{ has only one solution}$$

34. (d)  $\therefore \cos^{-1}(2x^2-1) = 2\pi - 2\cos^{-1}x$  if  $x < 0$

$$\text{So, } 2\pi - 2\cos^{-1}x - 2\sin^{-1}x = \pi$$

35. (b)  $\therefore \cos^{-1} \cos x = \cos^{-1} \cos(2\pi - x)$  for  $x \in \left( \frac{3\pi}{2}, 2\pi \right)$   
 $= 2\pi - x$

$$\sin^{-1} \sin x = x - 2\pi$$

$$\therefore \sin^{-1}(\cos(\cos^{-1}(\cos x) + \sin^{-1}(\sin x)))$$

$$= \sin^{-1}(\cos 0) = \sin^{-1}(1) = \frac{\pi}{2}$$

36. (d) (a)  $\cos(\tan^{-1}(\tan 4)) = \cos(\tan^{-1} \tan(4 - \pi))$

$$= \cos(4 - \pi) = -\cos 4 > 0$$

(b)  $\sin(\cot^{-1}(\cot 4)) = \sin(\cot^{-1}(\cot(4 - \pi)))$

$$= \sin(4 - \pi) = -\sin 4 > 0$$

(c)  $\tan(\cos^{-1}(\cos 5)) = \tan(\cos^{-1} \cos(2\pi - 5))$

$$= \tan(2\pi - 5) = -\tan 5 > 0$$

(d)  $\cot(\sin^{-1}(\sin 4)) = \cot(\sin^{-1}(\sin(\pi - 4)))$

$$= \cot(\pi - 4) = -\cot 4 < 0$$

37. (c) We have

$$S_1 = \sum x_1 = \sin 2\beta$$

$$S_2 = \sum x_1 x_2 = \cos 2\beta$$

$$S_3 = \sum x_1 x_2 x_3 = \cos \beta$$

$$S_4 = x_1 x_2 x_3 x_4 = -\sin \beta$$

So that  $\sum_{i=1}^4 \tan^{-1} x_i = \tan^{-1} \frac{S_1 - S_3}{1 - S_2 + S_4}$   
 $= \tan^{-1} \frac{\sin 2\beta - \cos \beta}{1 - \cos 2\beta - \sin \beta} = \tan^{-1} \frac{\cos \beta (2 \sin \beta - 1)}{\sin \beta (2 \sin \beta - 1)}$   
 $= \tan \cot \beta = \tan^{-1} (\tan (\pi/2 - \beta)) = \pi/2 - \beta$

38. (a) Graph of  $\sin^{-1} \sin(x) = f(x)$

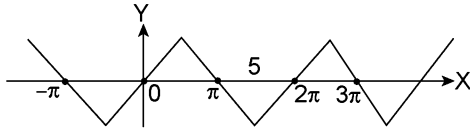

$f(x) = \sin^{-1}(\sin x) = x - 2\pi \quad 3\pi/2 \leq x \leq 5\pi/2$   
 $f(5) = \sin^{-1}(\sin 5) = 5 - 2\pi$   
 $\log_2(x) < 5 - 2\pi$   
 $x > 0$   
 $x < 2^{5-2\pi}$   
 So,  $(0, 2^{5-2\pi})$

39. (c)  $-\frac{\pi}{2} \leq \sin^{-1} x \leq \frac{\pi}{2}$

$\therefore \sin^{-1} x + \sin^{-1} y + \sin^{-1} z = \frac{3\pi}{2}$

$\Rightarrow \sin^{-1} x = \sin^{-1} y = \sin^{-1} z = \frac{\pi}{2}$

$\Rightarrow x = y = z = 1$

Also  $f(p+q) = f(p) \cdot f(q) \quad \forall p, q \in \mathbb{R} \quad \dots(1)$

Given  $f(1) = 1$

from (1),

$F(1+1) = f(1) \cdot f(1) \Rightarrow f(2) = 1^2 = 1$

from (2),  $f(2+1) = f(2) \cdot f(1)$

$\Rightarrow f(3) = 1^2 \cdot 1 = 1^3 = 1$

Now given expression  $= 3 - \frac{3}{3} = 2$

40. (b)  $\tan^{-1} x + \tan^{-1} \frac{1}{y} = \tan^{-1} 3$

$\Rightarrow \frac{xy+1}{y-x} = 3 \quad \text{or, } y = \frac{3x+1}{3-x}$

$y > 0 \Rightarrow \frac{3x+1}{3-x} > 0 \Rightarrow -\frac{1}{3} < x < 3$

$\therefore x = 1, 2$  and corresponding values of  $y$  are 2, 7. Hence two pairs (1, 2) and (2, 7) are possible.

41. (c) Since  $\frac{x}{y} \cdot \frac{x+y}{x-y} > 1$ . The given expression is equal to

$$\pi + \tan^{-1} \left[ \frac{\frac{x}{y} + \frac{x+y}{x-y}}{1 - \frac{x}{y} \times \frac{x+y}{x-y}} \right]$$

$= \pi + \tan^{-1} \frac{x^2 + y^2}{-(x^2 + y^2)} = \pi + \tan^{-1} (-1) = 3\pi/4.$

42. (c) Since  $\frac{3\pi}{2} < 5 < 2\pi$ ,

We have  $\sin 5 < 0$ , so  $\sin^{-1}(\sin 5) = 2\pi - 5$

Thus the given inequality can be written as

$2\pi - 5 > x^2 - 4x$  or  $x^2 - 4x - (2\pi - 5) < 0$

$\Rightarrow \left[ x - \frac{4 - \sqrt{16 - 4(2\pi - 5)}}{2} \right]$

$\left[ x - \frac{4 + \sqrt{16 - 4(2\pi - 5)}}{2} \right] < 0$

$\Rightarrow [x - 2 - \sqrt{9 - 2\pi}] [x - (2 + \sqrt{9 - 2\pi})] < 0$

$x \in (2 - \sqrt{9 - 2\pi}), (2 + \sqrt{9 - 2\pi}).$

43. (c)  $I = \tan^{-1} \left( \frac{1}{\sqrt{2}} \right) - \tan^{-1} \left\{ \frac{\sqrt{12 - (-1 + 2\sqrt{6})}}{(\sqrt{6} + 1)} \right\}$

$= \tan^{-1} \left( \frac{1}{\sqrt{2}} \right) - \tan^{-1} \left( \frac{\sqrt{5 - 2\sqrt{6}}}{\sqrt{6} + 1} \right)$

$= \tan^{-1} \left( \frac{1}{\sqrt{2}} \right) - \tan^{-1} \left( \frac{\sqrt{3} - \sqrt{2}}{1 + \sqrt{6}} \right)$

$= \tan^{-1} \left( \frac{1}{\sqrt{2}} \right) - \tan^{-1} \sqrt{3} + \tan^{-1} \sqrt{2}$

$= \frac{\pi}{2} - \frac{\pi}{3} = \frac{\pi}{6}.$

44. Here, the expression could be written as

$\Rightarrow \cos^{-1} x + \cos^{-1} \left\{ x \cdot \frac{1}{\sqrt{2}} + \sqrt{1 - x^2} \cdot \sqrt{1 - \left( \frac{1}{\sqrt{2}} \right)^2} \right\}$

$\Rightarrow \cos^{-1} x + \cos^{-1} \frac{1}{\sqrt{2}} - \cos^{-1} x$

$\left\{ \because \frac{1}{\sqrt{2}} < x \Rightarrow \cos^{-1} \frac{1}{\sqrt{2}} > \cos^{-1} x \right\}$

$\Rightarrow \cos^{-1} \frac{1}{\sqrt{2}} = \frac{\pi}{4}$

45. (c)  $k = \cos^{-1} x + \cos^{-1} \left[ \frac{x}{2} + \frac{1}{2} \sqrt{3 - 3x^2} \right] = \frac{\pi}{3}$

$\therefore -1 \leq x \leq 1$ , also  $3 - 3x^2 \geq 0$

$-1 \leq \frac{x}{2} + \frac{1}{2} \sqrt{3 - 3x^2} \leq 1$

$\Rightarrow -1 \leq x \leq 1$

$0 \leq \frac{x}{2} + 1 + \frac{1}{2} \sqrt{3 - 3x^2} \leq 1$

...(2)

Solving (2) we get option (c)

46. (d)  $\therefore$  The given equation can be written as

$\frac{x + \frac{1}{x}}{2} = -\sin(\cos^{-1} y) \quad (x \neq 0)$

$\therefore x + \frac{1}{x} \geq 2$  or  $x + \frac{1}{x} \leq -2$

$\therefore$  L.H.S. = R.H.S. if  $\sin(\cos^{-1} y) = \pm 1$  i.e.,  $x = \pm 1$

When  $x = -1$   $\sin(\cos^{-1} y) = 1$

$\Rightarrow y = 0$  as  $0 \leq \cos^{-1} y \leq \pi$

When  $x = 1$   $\sin(\cos^{-1} y) = -1$

Not possible as  $0 \leq \cos^{-1} y \leq \pi$

$\therefore x = -1, y = 0$  is only solution.

47. (d)  $\sin^{-1}x$  is defined if  $-1 \leq x \leq 1$  and  $\sin^{-1}(1-x)$  is defined if  $-1 \leq 1-x \leq 1 \Rightarrow 0 \leq x \leq 2$

$\therefore \sin^{-1}x + n \sin^{-1}(1-x)$  is defined if  $0 \leq x \leq 1$  when  $0 \leq x \leq 1$ , also  $0 \leq 1-x \leq 1$

So  $0 \leq \sin^{-1}x \leq \frac{\pi}{2}$  and  $0 \leq \sin^{-1}(1-x) \leq \frac{\pi}{2}$

$\therefore$  LHS  $\geq 0$  & RHS  $\leq 0$ , so equally holds if LHS = RHS = 0  
But LHS = 0 if  $\sin^{-1}x$  and  $n \sin^{-1}(1-x)$  are simultaneously zero, which is impossible.

48. (a)  $a = 0$

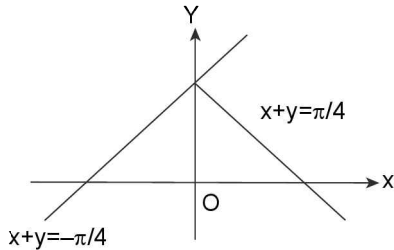

equation  $x + y = \frac{\pi}{2} - \frac{\pi}{4} \Rightarrow x + y = \frac{\pi}{4}$

image  $x - y + \frac{\pi}{4} = 0$

49. (a)  $\operatorname{cosec}(\operatorname{cosec}^{-1}x) = x \forall x \in \mathbb{R} - (-1, 1)$

also range of  $\operatorname{cosec}^{-1}(\operatorname{cosec} x) \in \left[-\frac{\pi}{2}, 0\right) \cup \left(0, \frac{\pi}{2}\right]$

so combining these two.

$$x \in \left[-\frac{\pi}{2}, -1\right] \cup \left[1, \frac{\pi}{2}\right]$$

50. (c) Let  $\cos^{-1}p = \alpha, \cos^{-1}q = \beta, \cos^{-1}r = \gamma$   
 $\cos \alpha = p, \cos \beta = q, \cos \gamma = r, \alpha + \beta + \gamma = \pi$

$\cos(\alpha + \beta) = \cos(\pi - \gamma)$

$\Rightarrow \cos \alpha \cos \beta - \sin \alpha \sin \beta = -\cos \gamma$

$\Rightarrow pq - \sqrt{1-p^2}\sqrt{1-q^2} = -r$

$\Rightarrow p^2 + q^2 + r^2 + 2pqr = 1$

$\Rightarrow p^2 + q^2 + r^2 + 2pqr + 4 = 5.$

51. (c) Clearly,  $x(x+1) \geq 0$  and  $x^2 + x + 1 \leq 1$ . Together they imply  $x(x+1) = 0$ .

$\therefore x = 0, -1.$

When  $x = 0,$

L.H.S. =  $\tan^{-1}0 + \sin^{-1}1 = \frac{\pi}{2}.$

When  $x = -1,$

L.H.S. =  $\tan^{-1}0 + \sin^{-1}\sqrt{1-1+1} = 0 + \sin^{-1}1 = \frac{\pi}{2},$

Thus two solution.

**SECTION-IV (MORE THAN ONE CORRECT ANSWERS)**

1. (a, b, d)

(a)  $\tan |\tan^{-1}x| = |x|$

For  $x \geq 0 \tan(\tan^{-1}x) = x = |x|$

For  $x < 0 \tan |-\tan^{-1}x| = \tan(\tan^{-1}|x|) = |x|$

(b)  $\cot |\cot^{-1}x| = \cot(\cot^{-1}x)$  as  $\cot^{-1}x \geq 0$  and  $\cot(\cot^{-1}x) = x$

$$(c) \tan^{-1} |\tan x| = \begin{cases} \tan^{-1}(\tan x) & \text{for } x \geq 0 \\ -\tan^{-1}(\tan x) & \text{for } x < 0 \end{cases}$$

$$= \begin{cases} x & \text{for } x \in \left[0, \frac{\pi}{2}\right) \\ -x & \text{for } x \in \left(-\frac{\pi}{2}, 0\right) \end{cases}$$

Thus  $\tan^{-1} |\tan x| = |x|$  for  $x \in \left(-\frac{\pi}{2}, \frac{\pi}{2}\right)$

$\therefore$  (c) is false

(d)  $\sin |\sin x| = \begin{cases} \sin(\sin^{-1}x) & \text{for } 0 \leq x \leq 1 \\ -\sin(\sin^{-1}x) & \text{for } -1 \leq x < 0 \end{cases}$

$= \begin{cases} x & \text{for } 0 \leq x \leq 1 \\ -x & \text{for } -1 \leq x < 0 \end{cases} = |x|$  for  $x \in [-1, 1]$  which is domain of  $\sin^{-1}x$ .

2. (a, c)  $f(x) = \tan \left\{ \frac{1}{2} \sin^{-1} \left( \frac{2x}{1+x^2} \right) + \frac{1}{2} \cos^{-1} \left( \frac{1-x^2}{1+x^2} \right) \right\}$

$$\therefore 2 \tan^{-1} x = \begin{cases} \sin^{-1} \left( \frac{2x}{1+x^2} \right) & \text{for } x \in [-1, 1] \\ -\pi - \sin^{-1} \left( \frac{2x}{1+x^2} \right) & \text{for } x < -1 \Rightarrow \sin^{-1} \left( \frac{2x}{1+x^2} \right) \\ \pi - \sin^{-1} \left( \frac{2x}{1+x^2} \right) & \text{for } x > 1 \end{cases}$$

$$= \sin^{-1} \left( \frac{2x}{1+x^2} \right) = \begin{cases} 2 \tan^{-1} x & \text{for } x \in [-1, 1] \\ -\pi - 2 \tan^{-1} x & \text{for } x < -1 \\ \pi - 2 \tan^{-1} x & \text{for } x > 1 \end{cases}$$

Also  $2 \tan^{-1} x = \begin{cases} \cos^{-1} \left( \frac{1-x^2}{1+x^2} \right) & \text{for } x \geq 0 \\ -\cos^{-1} \left( \frac{1-x^2}{1+x^2} \right) & \text{for } x < 0 \end{cases} \Rightarrow \cos^{-1} \left( \frac{1-x^2}{1+x^2} \right)$

$$= \begin{cases} 2 \tan^{-1} x & \text{for } x \geq 0 \\ -2 \tan^{-1} x & \text{for } x < 0 \end{cases}$$

$\therefore \frac{1}{2} \sin^{-1} \left( \frac{2x}{1+x^2} \right) + \frac{1}{2} \cos^{-1} \left( \frac{1-x^2}{1+x^2} \right)$

$$= \begin{cases} \frac{\pi}{2} - 2 \tan^{-1} x & \text{for } x \leq -1 \\ 0 & \text{for } -1 \leq x \leq 0 \\ 2 \tan^{-1} x & \text{for } 0 \leq x \leq 1 \\ \frac{\pi}{2} & \text{for } x \geq 1 \end{cases}$$

$\Rightarrow f(x) = \tan \left\{ \frac{1}{2} \sin^{-1} \left( \frac{2x}{1+x^2} \right) + \frac{1}{2} \cos^{-1} \left( \frac{1-x^2}{1+x^2} \right) \right\}$

$= \tan \{ 2 \tan^{-1} x \} = \tan \left( \tan^{-1} \left( \frac{2x}{1-x^2} \right) \right) = \frac{2x}{1-x^2}$

for  $0 \leq x < 1$

And  $f(x) = \tan\{0\} = 0$  for  $-1 \leq x \leq 0$  and

$$f(x) = \tan\left\{-\frac{\pi}{2} - 2 \tan^{-1} x\right\}$$

$$= -\tan\left(\frac{\pi}{2} + \tan^{-1} x\right) = \cot(\tan^{-1} x)$$

$$= \cot\left(-\pi + \cot^{-1}\left(\frac{1}{x}\right)\right) = -\cot\left(\pi - \cot^{-1}\left(\frac{1}{x}\right)\right)$$

$$= \cot\left(\cot^{-1}\frac{1}{x}\right) = \frac{1}{x} \text{ for } x < -1 \text{ and}$$

$$f(x) = \tan\left\{\frac{\pi}{2}\right\} = \text{Not definite for } x > 1$$

3. (a, b, c)  $\tan^{-1} y = 4 \tan^{-1} x$

$\Rightarrow \tan(\tan^{-1} y) = \tan(4 \tan^{-1} x)$

$\Rightarrow y = \tan(4 \tan^{-1} x)$

y is not defined for  $4 \tan^{-1} x = -\frac{3\pi}{2}$  or  $\frac{\pi}{2}$  or  $\frac{3\pi}{2}$  as  $4 \tan^{-1} x$

$x \in (-2\pi, 2\pi)$

$\Rightarrow \tan^{-1} x = \frac{-3\pi}{8}$  or  $\frac{\pi}{8}$  or  $\frac{3\pi}{8}$

$\Rightarrow x = \pm \tan\left(\frac{3\pi}{8}\right)$  or  $\tan\left(\frac{\pi}{8}\right)$

$\Rightarrow x = \pm\left(\frac{\pi}{2} - \frac{\pi}{8}\right)$  or  $\tan\frac{\pi}{8}$

$\Rightarrow x = \pm \cot\frac{\pi}{8}$  or  $\tan\frac{\pi}{8}$

$\Rightarrow$  Now  $1 = \frac{2 \tan \pi / 8}{1 - \tan^2 \pi / 8}$

$\Rightarrow 1 = \frac{2x}{1-x^2}$  or  $1 = \frac{2/x}{1-1/x^2}$  or  $1 = \frac{-2/x}{1-1/x^2}$

$\Rightarrow \begin{cases} 1-x^2 = 2x \\ \text{or } x^2 - 1 = 2x \\ \text{or } x^2 - 1 = -2x \end{cases} \dots\dots(i)$

$\Rightarrow \begin{cases} x^2 + 2x - 1 = 0 \\ x^2 - 2x - 1 = 0 \\ x^2 + 2x - 1 = 0 \end{cases} \dots(ii)$

$\Rightarrow \begin{cases} x = \frac{-2 \pm \sqrt{4+4}}{2} \\ \text{or from (ii)} \\ x = \frac{-2 \pm \sqrt{4+4}}{2} \end{cases}$

$\Rightarrow x = -1 \pm \sqrt{2}$  or  $1 \pm \sqrt{2}$

$\Rightarrow x^2 = 3 \pm 2\sqrt{2} \Rightarrow$  Option (a), (b)

Also  $x^2 - 1 \pm 2x$  (from (i))

$\Rightarrow x^4 - 2x^2 + 1 = 4x^2 \Rightarrow x^4 = 6x^2 - 1$

$\Rightarrow$  Option (c)

4. (a, c, d)  $\sin^{-1}(x^2 + x + 1) + \cos^{-1}(ax + 1) = \pi/2 \dots(i)$

$\Rightarrow x^2 + x + 1 = ax + 1 \dots(ii)$

$\Rightarrow x^2 + (1-a)x = 0$

It has exactly two solutions.

$\Rightarrow$  Exactly two real roots (different)

$\Rightarrow$  Disc.  $> 0 \Rightarrow (1-a)^2 - 4(1)(0) > 0$

$\Rightarrow (1-a)^2 > 0 \Rightarrow a \neq 1$

$\therefore$  1 is the only integer that 'a' can't attain to satisfy equation 2.

Now  $\frac{3}{4} \leq x^2 + x + 1 \leq 1$  and  $ax + 1 \in \left[\frac{3}{4}, 1\right]$

$\Rightarrow \frac{-1}{4} \leq x^2 + x \leq 0$

$x^2 + x \leq 0$  and  $4x^2 + 4x + 1 \geq 0$

$\Rightarrow x(x+1) \leq 0$  and  $(2x+1)^2 \geq 0$

$\Rightarrow x \in (-1, 0]$

For  $a = -1$

$x^2 + x + 1 = -x + 1$

$\Rightarrow x^2 + 2x = 0 \Rightarrow x(x+2) = 0$

$\Rightarrow x = 0$  or  $x = -2$

$\Rightarrow ax + 1 = 0$  or 3 but  $(ax + 1) \in \left[\frac{3}{4}, 1\right]$

and also  $-2 \notin [1, 0]$

$\therefore a \neq 1$ ; (only one solution, not two solution)

For  $a = 0$ ;  $x^2 + x + 1 = 1$

$\Rightarrow x(x+1) = 0 \Rightarrow x = 0$  or  $x = -1$

$\therefore \sin^{-1}(x^2 + x + 1) + \cos^{-1}(ax + 1) = \pi/2$  is satisfied by  $x = 0, x = -1$  and  $a = 0$

For  $a = 2$

$x^2 + x + 1 = 2x + 1 \Rightarrow x^2 - x = 0$

$\Rightarrow x = 0$  or 1, but  $1 \notin [-1, 0]$

Thus  $a \neq -1, 1$  and 2.

5. (a, b, c, d)  $\sin^{-1}|\sin x| = \sqrt{\sin^{-1}|\sin x|}$

Let  $\sin^{-1}|\sin x| = k$

$\therefore k = \sqrt{k}$

$\Rightarrow k^2 - k = 0 \Rightarrow k = 0$  or  $k = 1$

$\Rightarrow \sin^{-1}|\sin x| = 0$  or 1

$\Rightarrow |\sin x| = 0$  or  $|\sin x| = \sin 1$

$\Rightarrow \sin x = 0$  or  $\sin x = \sin(\pm 1)$

$\Rightarrow x = n\pi$  or  $x = n\pi + (-1)^n(\pm 1)$

$\Rightarrow x = n\pi$  or  $n\pi \pm (-1)^n$ ;  $n \in \mathbb{Z}$

$\Rightarrow x = n\pi, n\pi + 1, n\pi - 1$ ;  $n \in \mathbb{Z}$  are the values satisfying the given equation.

6. (b, c, d)

$\tan^{-1}(\sin^2 \theta + 2 \sin \theta + 2) + \cot^{-1}(4 \sec^2 \phi + 1) = \frac{\pi}{2}$

$\Rightarrow \sin^2 \theta + 2 \sin \theta + 2 = 4 \sec^2 \phi + 1$

$\Rightarrow \sin^2 \theta + 2 \sin \theta + 1 = 4 \sec^2 \phi$

$\Rightarrow (\sin \theta + 1)^2 = 4 \sec^2 \phi$

$\Rightarrow \sin \theta + 1 = \pm (4 \sec^2 \phi)^{1/2} = \pm (2 \sec^2 \phi)^{1/2}$

4.128 > Trigonometry

$$\begin{aligned} \Rightarrow \sin\theta + 1 &= \pm \left(2^{\sec^2\phi}\right) \therefore \sec^2\phi \in [1, \infty) \\ \Rightarrow 2^{\sec^2\phi} &\in [2, \infty) \\ \Rightarrow -2^{\sec^2\phi} &\in (-\infty, -2] \text{ and } 2^{\sec^2\phi} \in [2, \infty) \\ \therefore \sin\theta + 1 &= 2\sec^2\phi \text{ and } = -2\sec^2\phi \text{ (impossible)} \\ \Rightarrow \sin\theta &= 1; \sec^2\phi = 1 \\ \Rightarrow \theta &= \left(2n\pi + \frac{\pi}{2}\right) \text{ and } \phi = n\pi, n \in \mathbb{Z} \\ \text{and } \sin\theta &= 1; \cos\phi = \pm 1 \end{aligned}$$

7. (a, b, d)  $\tan^{-1}\left(\frac{a}{x}\right) + \tan^{-1}\left(\frac{b}{c}\right) = \frac{\pi}{2}$ ; clearly  $x \neq 0$

$$\Rightarrow \tan^{-1}\left(\frac{a}{x}\right) + \cot^{-1}\left(\frac{x}{b}\right) = \frac{\pi}{2}$$

$$\Rightarrow \frac{a}{x} = \frac{x}{b} \Rightarrow x^2 = ab \Rightarrow ab > 0 \text{ as } x \neq 0$$

$$\Rightarrow x = \pm\sqrt{ab}$$

From given equation, it is obvious that if atleast one of

$\tan^{-1}\left(\frac{a}{x}\right)$  or  $\tan^{-1}\left(\frac{b}{x}\right)$  is negative, then the sum  $\neq \pi/2$

$$\Rightarrow \frac{a}{x} \text{ and } \frac{b}{x} > 0 \quad \Rightarrow a, x, b, x > 0$$

$\Rightarrow$  For  $a, b < 0, x < 0$  and for  $a, b > 0, x > 0$

$\therefore$  for  $a, b < 0, x = -\sqrt{ab}$  and for  $a, b > 0, x = \sqrt{ab}$

$\therefore$  for  $a, b < 0$ , no value of  $x$  exists

$$8. \text{ (a, c) } 2\tan^{-1}x = \begin{cases} \sin^{-1}\left(\frac{2x}{1+x^2}\right) \text{ for } -1 \leq x \leq 1 \\ -\pi - \sin^{-1}\left(\frac{2x}{1+x^2}\right) \text{ for } x \leq -1 \\ \pi - \sin^{-1}\left(\frac{2x}{1+x^2}\right) \text{ for } x \geq 1 \end{cases}$$

$$\Rightarrow 2\tan^{-1}x + \sin^{-1}\left(\frac{2x}{1+x^2}\right) = \begin{cases} -\pi \text{ for } x \leq -1 \\ \pi \text{ for } x \geq 1 \\ 4\tan^{-1}x \text{ for } -1 \leq x \leq 1 \end{cases}$$

$$\Rightarrow 2\tan^{-1}x + \sin^{-1}\left(\frac{2x}{1+x^2}\right) \text{ is independent of } x \text{ for}$$

$$x \in (-\infty, -1] \cup [1, \infty)$$

9. (a, b) Domain of  $\sin^{-1}x$  and  $\cos^{-1}x$ , each is  $[-1, 1]$  and that of  $\sec^{-1}x$  and  $\csc^{-1}x$ , each is  $(-\infty, -1] \cup [1, \infty)$

$\therefore$  Domain of  $f(x)$  must be  $\{-1, 1\}$   $\therefore$  Range of  $f(x)$  will be  $\{f(-1), f(1)\}$

where  $f(-1) = \sin^{-1}(-1) \cdot \cos^{-1}(-1) \cdot \tan^{-1}(-1) \cdot \cot^{-1}(-1) \cdot \sec^{-1}(-1) \cdot \csc^{-1}(-1)$

$$= \left(\frac{-\pi}{2}\right) \cdot (\pi) \cdot \left(\frac{-\pi}{4}\right) \cdot \left(\frac{3\pi}{4}\right) \cdot (\pi) \cdot \left(\frac{-\pi}{2}\right) = \frac{-3\pi^6}{64} \text{ and } f(1)$$

$$= 0 \text{ \{as } \cos^{-1}1 = 0\}}$$

(i) Thus, the graph of  $f(x)$  is a two point graph which doesn't lie above  $x$ -axis.

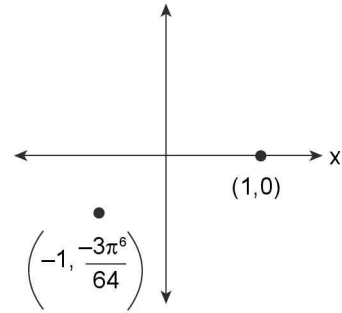

(ii)  $f(x)_{\max} = 0$  and  $f(x)_{\min} = \frac{-3\pi^6}{64}$

$$\text{Hence } |f(x)_{\max} - f(x)_{\min}| = \frac{3\pi^6}{64}$$

(iii)  $f(x)$  is one-one hence injective.

(iv) Domain is  $\{-1, 1\}$

$\therefore$  Number of non-negative integers in the domain of  $f(x)$  is one.

10. (a, b, d) We have  $f(x) = \cos^{-1}(-\{-x\})$

$$D_f = \mathbb{R}$$

$$\text{As } 0 \leq \{-x\} < 1 \quad \forall x \in \mathbb{R}$$

$$\Rightarrow -1 < -\{-x\} \leq 0$$

$$\text{So } R_f = \left[\frac{\pi}{2}, \pi\right]. \text{ Clearly, } f \text{ is neither even nor odd.}$$

But  $f(x+1) = f(x) \Rightarrow f$  is periodic with period 1.

11. (a, b, c, d) As  $\frac{-\pi}{2} \leq \sin^{-1}x \leq \frac{\pi}{2} \quad \forall -1 \leq x \leq 1$

$$\therefore 0 \leq (\sin^{-1}x)^2 \leq (\sin^{-1}y)^2 + (\sin^{-1}z)^2 \leq \frac{3\pi^2}{4}$$

$$\therefore (\sin^{-1}x)^2 + (\sin^{-1}y)^2 + (\sin^{-1}z)^2 = \frac{3\pi^2}{4} \text{ is possible if } x,$$

$$y, z \in \{-1, 1\}$$

$\therefore$  Possible values of  $x - y + z$  from the ordered triplet  $(x, y, z)$  are as follows :

$(x, y, z)$	$x - y + z$
$(-1, -1, -1)$	$-1$
$(-1, 1, 1)$	$-1$
$(1, -1, 1)$	$3$
$(1, 1, -1)$	$-1$
$(1, 1, 1)$	$1$
$(1, -1, -1)$	$-1$
$(-1, 1, -1)$	$-3$
$(-1, -1, 1)$	$1$

Hence set of values of  $x - y + z$  is  $\{\pm 1, \pm 3\}$

12. (a, b)  $\angle B = \sec^{-1}\left(\frac{5}{4}\right) + \csc^{-1}\sqrt{5} = \tan^{-1}\left(\frac{3}{4}\right) + \tan^{-1}\left(\frac{1}{2}\right)$

$$= \tan^{-1}\frac{\frac{3}{4} + \frac{1}{2}}{1 - \frac{3}{4} \cdot \frac{1}{2}} = \tan^{-1}2$$

$$\angle C = \operatorname{cosec}^{-1}\left(\frac{25}{7}\right) + \cot^{-1}\left(\frac{9}{13}\right) = \tan^{-1}$$

$$\left(\frac{7}{24}\right) + \tan^{-1}\left(\frac{13}{9}\right) = \tan^{-1}\left(\frac{\frac{7}{24} + \frac{13}{9}}{1 - \frac{7}{24} \cdot \frac{13}{9}}\right) = \tan^{-1} 3$$

$$\therefore \angle A = \pi - \angle B - \angle C = \pi - \tan^{-1} 2 - \tan^{-1} 3 = \tan^{-1} 1$$

$$\therefore \sin A = \frac{1}{\sqrt{2}}, \sin B = \frac{2}{\sqrt{5}} \text{ and } \sin C = \frac{3}{\sqrt{10}}$$

$$\therefore a = \sin A \cdot \frac{c}{\sin C} = \frac{1}{\sqrt{2}} \cdot \frac{3}{\left(\frac{3}{\sqrt{10}}\right)} = \sqrt{5} \text{ and}$$

$$b = \sin B \cdot \frac{c}{\sin C} = \frac{2}{\sqrt{5}} \cdot \frac{3}{\left(\frac{3}{\sqrt{10}}\right)} = \sqrt{2}$$

(1)  $\tan A = 1, \tan B = 2, \tan C = 3$  are in A.P. Ans. (a)

(2) The triangle with sides  $a^2, b^4$  and  $c$  will have side-length 5, 4 and 3 respectively

$\therefore$  distance between orthocentre and circumcentre = circumradius =  $\frac{\text{hypotenuse}}{2} = \frac{5}{2}$  Ans.

(3) Area of  $\triangle ABC, \Delta = \frac{1}{2} ab \sin C = \frac{1}{2} \cdot \sqrt{5} \cdot \sqrt{2} \cdot \frac{3}{\sqrt{10}}$   
 $= \frac{3}{10} = r \cdot s$

All other parameters are irrational. Ans. (d)

13. (a, b, c) The solution of  $y = \sqrt{y}$  is  $y = 0$  or  $y = 1$

If  $\sin^{-1} |\sin x| = 1 \Rightarrow x = 1$  or  $\pi - 1$  (in the interval  $(0, \pi)$ )

But  $y = \sin^{-1} |\sin x|$  is periodic with period  $\pi$ , so  $x = \pi n + 1$  or  $\pi n - 1$

Again if  $\sin^{-1} |\sin x| = 0 \Rightarrow x = \pi n$

14. (a, c, d) The equation holds if

$$\sin^2 \theta + 2 \sin \theta + 2 = 4^{\sec^2 \theta} + 1$$

Now L.H.S. =  $(\sin \theta + 1)^2 + 1 \leq 5$  and R.H.S.  $\geq 5$  ( $\because \sec^2 \theta \geq 1$ )

So, L.H.S. = R.H.S.  $\Rightarrow \sin \theta = -1$  and  $\sec^2 \theta = 1$

### SECTION-V (ASSERTION AND REASON TYPE ANSWERS)

1. (a) Clearly reason is true.

$$\sin^{-1}\left(\sin \frac{2\pi}{3}\right) = \sin^{-1}\left[\sin\left(\pi - \frac{\pi}{3}\right)\right] = \sin^{-1}\left(\sin\left(\frac{\pi}{3}\right)\right) = \frac{\pi}{3}$$

$\Rightarrow$  Assertion is true and reason correctly explains the reason.

2. (a) Clearly the reason is true.

$\cos^{-1}x + \cos^{-1}y = a + b$  (say); where  $a = \cos^{-1}x, b = \cos^{-1}y \in [0, \pi/2]$  as  $x, y > 0$  and  $x^2 + y^2 \leq 1$  i.e.,  $\cos^2 a + \cos^2 b \leq 1$

Now  $\cos(a + b) = \cos a \cdot \cos b - \sin a \cdot \sin b$

$$= (x \cdot y - \sqrt{1-x^2} \sqrt{1-y^2})$$

$$\Rightarrow \cos^{-1}[\cos(a + b)] = \cos^{-1}(xy - \sqrt{1-x^2} \sqrt{1-y^2})$$

$$\therefore a, b \in [0, \pi/2] \Rightarrow (a + b) \in [0, \pi]$$

$$\therefore a + b = \cos^{-1}(xy - \sqrt{1-x^2} \sqrt{1-y^2})$$

$$\Rightarrow \cos^{-1}x + \cos^{-1}y = \cos^{-1}(xy - \sqrt{1-x^2} \sqrt{1-y^2})$$

$\Rightarrow$  Assertion is true and reason correctly explains the reason.

3. (b)  $\tan^{-1}(1) + \cos^{-1}\left(-\frac{1}{2}\right) + \sin^{-1}\left(-\frac{1}{2}\right) = \frac{\pi}{4} + \frac{2\pi}{3} - \frac{\pi}{6} = \frac{3\pi}{4}$

$\Rightarrow$  Assertion is correct

Clearly reason is correct but no correction with assertion

4. (c)  $\tan^{-1}x + \tan^{-1}y = \tan^{-1}\left(\frac{x+y}{1-xy}\right)$  for  $xy < 1$

$\therefore$  Reason is incorrect

Also

$$\tan^{-1}x + \tan^{-1}y = \begin{cases} \pi + \tan^{-1}\left(\frac{x+y}{1-xy}\right) & \text{for } x > 0, y > 0 \text{ and } xy > 1 \\ -\pi + \tan^{-1}\left(\frac{x+y}{1-xy}\right) & \text{for } x < 0, y < 0 \text{ and } xy > 1 \end{cases}$$

$$\therefore \tan^{-1}2 + \tan^{-1}3 = \pi + \tan^{-1}\left(\frac{2+3}{1-2 \times 3}\right) = \pi + \tan^{-1}(-1)$$

$$= \pi - \frac{\pi}{4} = \frac{3\pi}{4} \quad \Rightarrow \text{Assertion is correct}$$

5. (a) Clearly reason is correct. Now let  $\cot^{-1}(-x) = \theta \in (0, \pi)$

$$\Rightarrow \cot(\theta) = -x \quad \Rightarrow x = -\cot(\theta)$$

$$\Rightarrow \cot^{-1}x = \cot^{-1}(-\cot(\theta)) \quad \dots (i)$$

$$\Rightarrow \cot^{-1}x = \cot^{-1}(\cot(\pi - \theta))$$

$$\Rightarrow \cot^{-1}x = \pi - \theta \text{ as } \theta \in (0, \pi)$$

$$\Rightarrow \pi - \theta \in (0, \pi)$$

The above step is due to the reason that range of  $\cot^{-1}x$  is  $(0, \pi)$

$$\Rightarrow \cot^{-1}(\cot x) = x \text{ for } x \in (0, \pi)$$

$$\Rightarrow \cot^{-1}x = \pi - \cot^{-1}(-x)$$

$$\Rightarrow \cot^{-1}(-x) = \pi - \cot^{-1}(x)$$

$\Rightarrow$  Both assertion and reason are correct and reason correctly explain the reason.

6. (c) Clearly the reason is incorrect.

Now  $\cot^{-1}2 + \cot^{-1}8 + \cot^{-1}18 + \cot^{-1}32 + \dots + \infty$

$$= \lim_{x \rightarrow \infty} \left[ \tan^{-1} \frac{1}{2} + \tan^{-1} \frac{1}{8} + \tan^{-1} \frac{1}{18} + \dots + \text{up to } n^{\text{th}} \text{ term} \right]$$

$$= \lim_{x \rightarrow \infty} \left[ \tan^{-1} \left( \frac{3-1}{1+1 \cdot 3} \right) + \tan^{-1} \left( \frac{5-3}{1+3 \cdot 5} \right) + \dots + \text{up to } n^{\text{th}} \text{ term} \right]$$

$$= \lim_{x \rightarrow \infty} \left[ \tan^{-1}(2n+1) - \tan^{-1}1 \right]$$

$$= \tan^{-1} \infty - \tan^{-1}1 = \frac{\pi}{2} - \frac{\pi}{4} = \frac{\pi}{4}$$

$\Rightarrow$  Assertion is correct



4.130 > Trigonometry

7. (b) Reason is correct.

$$\because \text{Range of } \sin^{-1} \text{ is } \left[ \frac{\pi}{2}, \frac{\pi}{2} \right]$$

$$\therefore 2\sin^{-1}x + 3\sin^{-1}y = 5\pi/2$$

$$\Rightarrow \sin^{-1}x = \frac{\pi}{2} \text{ and } \sin^{-1}y = \frac{\pi}{2}$$

$$\Rightarrow x = y = 1 \quad \therefore y = kx - 5$$

$$\Rightarrow x = kx - 5 \quad \Rightarrow (k-1)x = 5$$

$$\Rightarrow k-1 = 5 (\because x = 1) \quad \Rightarrow k = 6$$

$\Rightarrow$  Assertion is true but reason has no connection with assertion

8. (d) Clearly reason is correct. Now  $\cos\left(\frac{1}{2}\cos^{-1}\frac{1}{8}\right)$

$$\text{Let } \cos \frac{\theta}{8} = \cos\left(0, \frac{\pi}{2}\right); \text{ thus to find } \cos\left(\frac{\theta}{2}\right)$$

$$\Rightarrow \cos \theta = \frac{1}{8} \quad \Rightarrow 2\cos^2 \frac{\theta}{2} - 1 = \frac{1}{8}$$

$$\Rightarrow 2\cos^2 \frac{\theta}{2} = \frac{9}{8} \quad \Rightarrow \cos^2 \frac{\theta}{2} = \frac{9}{16}$$

$$\Rightarrow \cos \frac{\theta}{2} = \pm \sqrt{\frac{9}{16}} \quad \Rightarrow \cos \frac{\theta}{2} = \frac{3}{4} \left( \because \frac{\theta}{2} \in (0, \pi/4) \right)$$

$\Rightarrow$  Assertion is incorrect

9. (d) Clearly, the reason is correct. Further  $3 \in \left(\frac{\pi}{2}, \pi\right)$

$$\text{So let } 3 = (\pi - \theta); \theta \in \left(0, \frac{\pi}{2}\right)$$

$$\therefore \sin^{-1}(\sin 3) = \sin^{-1}(\sin(\pi - \theta)) = \sin^{-1}(\sin \theta) = \theta \text{ as } \theta \in (0, \pi/2) = (\pi - 3) \Rightarrow \text{Assertion is incorrect}$$

10. (d) Clearly, the reason is correct. Now for  $x < 0$ ;

$$\tan^{-1}\left(\frac{1}{x}\right) = -\pi + \cot^{-1}x$$

$$\therefore \tan^{-1}x + \tan^{-1}1/x = \tan^{-1}x + (-\pi + \cot^{-1}x) = (\tan^{-1}x + \cot^{-1}x) - \pi = \frac{\pi}{2} - \pi = -\frac{\pi}{2}$$

$\Rightarrow$  Assertion is incorrect

11. (b) Clearly, reason is correct. Now  $x = \operatorname{cosec}(\tan^{-1}(\cos(\cot^{-1}(\sec(\sin^{-1}a))))); a \in [0, 1]$

$$= \operatorname{cosec}\left(\tan^{-1}\left(\cos\left(\cot^{-1}\left(\sec\left(\sec^{-1}\left(\frac{1}{\sqrt{1-a^2}}\right)\right)\right)\right)\right)\right)$$

$$= \operatorname{cosec}\left(\tan^{-1}\left(\cos\left(\cot^{-1}\left(\frac{1}{\sqrt{1-a^2}}\right)\right)\right)\right)$$

$$= \operatorname{cosec}\left(\tan^{-1}\left(\cos\left(\cos^{-1}\left(\frac{1}{\sqrt{2-a^2}}\right)\right)\right)\right)$$

$$= \operatorname{cosec}\left(\tan^{-1}\left(\frac{1}{\sqrt{2-a^2}}\right)\right)$$

$$= \operatorname{cosec}\left(\operatorname{cosec}^{-1}\left(\sqrt{3-a^2}\right)\right) = \sqrt{3-a^2}$$

Also  $y = \sec(\cot^{-1}(\sin(\tan^{-1}(\operatorname{cosec}(\cos^{-1}a))))); a \in [0, 1]$

$$= \sec\left(\cot^{-1}\left(\sin\left(\tan^{-1}\left(\operatorname{cosec}\left(\operatorname{cosec}^{-1}\left(\frac{1}{\sqrt{1-a^2}}\right)\right)\right)\right)\right)\right)$$

$$= \sec\left(\cot^{-1}\left(\sin\left(\tan^{-1}\left(\frac{1}{\sqrt{1-a^2}}\right)\right)\right)\right)$$

$$= \sec\left(\cot^{-1}\left(\sin\left(\sin^{-1}\left(\frac{1}{\sqrt{2-a^2}}\right)\right)\right)\right)$$

$$= \sec\left[\cot^{-1}\left(\frac{1}{\sqrt{2-a^2}}\right)\right] = \sec[\sec^{-1}(\sqrt{3-a^2})] = \sqrt{3-a^2}$$

$$\therefore x = y \quad \Rightarrow \text{Assertion is correct}$$

These is no connection between reason and assertion

12. (a)  $\cos^{-1}x, (\sin^{-1}y)^2 \geq 0$

$\therefore$  By A.M. G.M. inequality

$$(\cos^{-1}x) + (\sin^{-1}y)^2 \geq 2\sqrt{\cos^{-1}x \cdot (\sin^{-1}y)^2} = 2\sqrt{\frac{\pi^4}{16}} = \frac{\pi^2}{2},$$

$$\text{but given } \cos^{-1}x + (\sin^{-1}y)^2 = \frac{p\pi^2}{4} \Rightarrow \frac{p\pi^2}{4} \geq \frac{\pi^2}{2} \Rightarrow p \geq 2$$

$$\text{Also } (\cos^{-1}x) + (\sin^{-1}y)^2 \leq \left(\pi + \frac{\pi^2}{4}\right)$$

For  $p = 2$ ,  $\cos^{-1}x + (\sin^{-1}y)^2$

$$= \frac{p\pi^2}{4} = \frac{\pi^2}{2} = \left(\frac{\pi^2}{4} + \frac{\pi^2}{4}\right) < \left(\pi + \frac{\pi^2}{4}\right)$$

$\therefore \pi = 2$  is the only permissible integer value.

$$\text{For } p = 3, \cos^{-1}x + (\sin^{-1}y)^2 = \frac{3\pi^2}{4} = \frac{\pi^2}{2} + \frac{\pi^2}{4} > \left(\pi + \frac{\pi^2}{4}\right)$$

$\therefore \pi = 2$  is the only permissible integer value.

$$\text{Now for } P = 2, \cos^{-1} + (\sin^{-1}y)^2 = \frac{\pi^2}{2} \text{ and } (\cos^{-1}x).$$

$$(\sin^{-1}y)^2 = \frac{\pi^4}{16}$$

$$\Rightarrow \cos^{-1}x$$

$$= \frac{\pi^4}{4} \& (\sin^{-1}y)^2 = \frac{\pi^2}{4} \Rightarrow x = \cos\left(\frac{\pi^2}{4}\right) \text{ and } y = \pm 1$$

are the only solution for permissible integer value  $p = 2$

$\therefore$  Both assertion and reason are correct and reason correctly explain the assertion.

13. (a) Clearly, reason is correct.  $\sum_{i=1}^{2n} \sin^{-1}x_i = n\pi = 2n\left(\frac{\pi}{2}\right)$

$$\Rightarrow \text{For each } i, \sin^{-1} = \pi/2 \quad (\because \sin^{-1}x_i \leq \pi/2)$$

$$\Rightarrow x_i = 1 \text{ for each } i$$

$$\therefore \sum_{i=1}^n x_i = \sum_{i=1}^n x_i^2 = \sum_{i=1}^n x_i^3 = n$$

$\Rightarrow$  Assertion is correct

$\therefore$  Both assertion and reason are correct and reason correctly explains the assertion.

## SECTION-VI (LINKED COMPREHENSION TYPE ANSWERS)

## Passage A:

$$1. (c) \sin^{-1}(\sin\theta) = \pi - \theta$$

$$\Rightarrow \sin^{-1}(\sin(\pi - \theta)) = \pi - \theta$$

$$\Rightarrow (\pi - \theta) \in \left[-\frac{\pi}{2}, \frac{\pi}{2}\right] \Rightarrow (\theta - \pi) \in \left[-\frac{\pi}{2}, \frac{\pi}{2}\right]$$

$$\Rightarrow \theta \in \left[\frac{\pi}{2}, \frac{3\pi}{2}\right]$$

$$2. (b) \sin^{-1}x = 2\sin^{-1}y$$

$$\text{L.H.S.} \in \left[-\frac{\pi}{2}, \frac{\pi}{2}\right] \text{ for } x \in [-1, 1]$$

$$\therefore \text{R.H.S. must belong to } \left[-\frac{\pi}{2}, \frac{\pi}{2}\right]$$

$$\Rightarrow \sin^{-1}y \in \left[-\frac{\pi}{4}, \frac{\pi}{4}\right] \Rightarrow y \in \left[\frac{-1}{\sqrt{2}}, \frac{1}{\sqrt{2}}\right]$$

$$\Rightarrow y \in \left[\frac{-1}{\sqrt{2}}, \frac{1}{\sqrt{2}}\right] \Rightarrow |y| \leq \frac{1}{\sqrt{2}}$$

$$3. (c) 2\sin^{-1}x = \sin^{-1}(2x\sqrt{1-x^2})$$

$$\text{For } x \in [-1, 1]; \text{R.H.S.} \in \left[-\frac{\pi}{2}, \frac{\pi}{2}\right]$$

$$\Rightarrow \text{L.H.S. must belong to } \left[-\frac{\pi}{2}, \frac{\pi}{2}\right]$$

$$\Rightarrow 2\sin^{-1}x \in \left[-\frac{\pi}{2}, \frac{\pi}{2}\right]$$

$$\Rightarrow \sin^{-1}x \in \left[-\frac{\pi}{4}, \frac{\pi}{4}\right] \Rightarrow x \in \left[\frac{-1}{\sqrt{2}}, \frac{1}{\sqrt{2}}\right]$$

## Passage B:

$$4. (c) \text{ Let } \sin^{-1}(-x) = \theta; -x \in [-1, 1]; \theta \in \left[\frac{\pi}{2}, \frac{3\pi}{2}\right]$$

$$\Rightarrow \sin(\theta) = -x \Rightarrow -\sin(2\pi - \theta) = -x$$

$$\Rightarrow \sin(2\pi - \theta) = x$$

$$\text{Now } -\theta \in \left[-\frac{3\pi}{2}, -\frac{\pi}{2}\right]$$

$$\Rightarrow 2\pi - \theta \in \left[\frac{\pi}{2}, \frac{3\pi}{2}\right] \text{ i.e., principal domain of } \sin^{-1}x \text{ in}$$

$$\text{which } \sin^{-1}x \text{ is one-one}$$

$$\text{i.e., } \sin^{-1}(\sin x) = x \text{ for } x \in \text{principal domain of } \sin x$$

$$\therefore \sin^{-1}(\sin(2\pi - \theta)) = \sin^{-1}x$$

$$\Rightarrow (2\pi - \theta) = \sin^{-1}x \Rightarrow \theta = 2\pi - \sin^{-1}x$$

$$5. (b) f(x) = 3\sin^{-1}x - 2\cos^{-1}x$$

$$\Rightarrow f(-x) = 3\sin^{-1}(-x) - 2\cos^{-1}(-x) \dots (i)$$

$$\text{We earlier proved } \sin^{-1}(-x) = 2\pi - \sin^{-1}x \dots (ii)$$

$$\text{Now, let } \cos^{-1}(-x) = \theta; -x \in [-1, 1] \text{ and } \theta \in [\pi, 2\pi]$$

$$\Rightarrow \cos\theta = -x \Rightarrow -\cos(3\pi - \theta) = -x$$

$$\Rightarrow \cos(3\pi - \theta) = x$$

$$(\because -\theta \in [-2\pi, -\pi] \Rightarrow 3\pi - \theta \in [\pi, -\pi] \text{ principal domain of } \cos x)$$

$$\Rightarrow \cos^{-1}(\cos(3\pi - \theta)) = \cos^{-1}x$$

$$\Rightarrow 3\pi - \theta = \cos^{-1}x \Rightarrow \theta = 3\pi - \cos^{-1}x \dots (iii)$$

$$\text{Using (ii) and (iii) in (i) we have, } f(-x) = 3[2\pi - \sin^{-1}x] - 2[3\pi - \cos^{-1}x]$$

$$= -3\sin^{-1}x + 2\cos^{-1}x = -[3\sin^{-1}x - 2\cos^{-1}x] = -f(x)$$

$$\Rightarrow f(x) \text{ is an odd function}$$

$$6. (a) \text{ Let } E = (\sin^{-1}x)^3 - (\cos^{-1}x)^3 = (\sin^{-1}x \cos^{-1}x) [(\sin^{-1}x)^2 + (\cos^{-1}x)^2 + (\sin^{-1}x)(\cos^{-1}x)]$$

$$= (\sin^{-1}x \cos^{-1}x) [(\sin^{-1}x + \cos^{-1}x)^2 - \sin^{-1}x \cos^{-1}x] \dots (i)$$

$$\text{Let } \sin^{-1}x = \theta; \theta \in \left[\frac{\pi}{2}, \frac{3\pi}{2}\right]$$

$$\Rightarrow x = \sin\theta = \cos\left(\frac{5\pi}{2} - \theta\right)$$

$$\Rightarrow \cos^{-1}x = \cos^{-1}\left(\cos\left(\frac{5\pi}{2} - \theta\right)\right)$$

$$\Rightarrow \cos^{-1}x = \frac{5\pi}{2} - \theta, \text{ since } \frac{5\pi}{2} - \theta \in [\pi, 2\pi] \text{ principal domain of } \cos x$$

$$\Rightarrow \cos^{-1}x + \sin^{-1}x = \frac{5\pi}{2} \dots (ii)$$

$$\text{Using (ii) in (i) we get,}$$

$$E = (\sin^{-1}x - \cos^{-1}x) \left[ \frac{25x^2}{4} - \sin^{-1}x \cos^{-1}x \right]$$

$$= \left[ \sin^{-1}x - \left(\frac{5\pi}{2} - \sin^{-1}x\right) \right] \left[ \frac{25\pi^2}{4} - \sin^{-1}x \left(\frac{5\pi}{2} - \sin^{-1}x\right) \right]$$

$$= \left[ 2\sin^{-1}x - \frac{5\pi}{2} \right] \left[ \frac{25\pi^2}{4} + (\sin^{-1}x)^2 - \frac{5\pi}{2} \sin^{-1}x \right]$$

$$= \left( 2\sin^{-1}x - \frac{5\pi}{2} \right) \left[ (\sin^{-1}x)^2 - \frac{5\pi}{2} \sin^{-1}x + \frac{n\pi^2}{4} \right]$$

$$= \left[ 2\sin^{-1}x - \frac{5\pi}{2} \right] \left[ \left(\sin^{-1}x - \frac{5\pi}{4}\right)^2 + \frac{25\pi^2}{4} - \frac{25\pi^2}{16} \right]$$

$$= \left( 2\sin^{-1}x - \frac{5\pi}{4} \right) \left[ \left(\sin^{-1}x - \frac{5\pi}{4}\right)^2 + \frac{75\pi^2}{16} \right]$$

$$\text{Let } \sin^{-1}x - \frac{5\pi}{4} = t \in \left[-\frac{3\pi}{4}, \frac{\pi}{4}\right]$$

$$\Rightarrow E = 2t \left( t^2 + \frac{75\pi^2}{16} \right) = 2t^3 + \frac{75}{8} \pi^2 t$$

$$\Rightarrow \frac{dE}{dt} = 6t^2 + \frac{75}{8} \pi^2 > 0$$

$\Rightarrow E$  is an increasing function

$$\therefore \text{ Minimum value } E \text{ occurs at } \sin^{-1}x - \frac{5\pi}{4} = -\frac{3\pi}{4}$$

$$\therefore E_{\min} = 2 \left( -\frac{3\pi}{4} \right) \left[ \left( -\frac{3\pi}{4} \right)^2 + \frac{75\pi^2}{16} \right] = \left( -\frac{3\pi}{2} \right) \left[ \frac{21\pi^2}{4} \right]$$

$$= \frac{-63\pi^3}{8}$$

7. (c) Already proved that  $\sin^{-1}x + \cos^{-1}x = \frac{5\pi}{2}$

4.132 > Trigonometry

8. (a) Co-domain of  $\sin^{-1}x$  is  $\left[-\frac{5\pi}{2}, \frac{-3\pi}{2}\right]$  .....(i)

Also given  $\sin^{-1}x + \cos^{-1}x = 5\pi/2$  .....(ii)  
For invertible function co-domain = Range

$\therefore$  Range (co-domain) of  $\sin^{-1}x = \left[-\frac{5\pi}{2}, \frac{3\pi}{2}\right]$

$\Rightarrow \sin^{-1}x + \cos^{-1}x = \frac{5\pi}{2}$

$\Rightarrow \cos^{-1}x = 5\pi/2 - \sin^{-1}x$

$\Rightarrow \cos^{-1}x = \frac{5\pi}{2} - \theta; \theta = \sin^{-1}x \in \left[-\frac{5\pi}{2}, \frac{-3\pi}{2}\right]$

$\Rightarrow \cos^{-1}x = \cos^{-1}\left(\cos\left(\frac{5\pi}{2} - \theta\right)\right)$

Iff  $\frac{5\pi}{2} - \theta \in$  principal domain of  $\cos x$  or co-domain of

$\cos^{-1}x$ , but  $-\theta \in \left[\frac{3\pi}{2}, \frac{5\pi}{2}\right]$

$\Rightarrow \left(\frac{5\pi}{2} - \theta\right) \in [4\pi, 5\pi]$

$\therefore$  co-doming of  $\cos^{-1} = [4\pi, 5\pi]$

9. (a)  $\sec^2(\tan^{-1}2) + \operatorname{cosec}^2(\cot^{-1}3) + 2 = [\sec(\tan^{-1}2)]^2 + [\operatorname{cosec}(\cot^{-1}3)]^2 + 2$

$= \sec^2\theta + \operatorname{cosec}^2\phi + 2$  (say);  $\theta = \tan^{-1}2$ ;  $\phi = \cot^{-1}3$  .....(i)

$\theta \in \left(\pi, \frac{3\pi}{2}\right)$  and  $\phi \in \left(\pi, \frac{3\pi}{2}\right)$

$\Rightarrow \tan\theta = 2$  and  $\cot\phi = 3$

$\Rightarrow \sec\theta = -\sqrt{5}$  and  $\operatorname{cosec}\phi = -\sqrt{10}$

$\therefore$  Given expression  $= (-\sqrt{5})^2 + (-\sqrt{10})^2 + 2 = 17$

Passage C:

10. (b)  $(\cos^{-1}x) + (\sin^{-1}y)^2 = \frac{a\pi^2}{4}$  and  $|x| \leq 1$ ;  $|y| \leq 1$

$\cos^{-1}x \in [0, \pi]$        $(\sin^{-1}y)^2 \in \left[0, \frac{\pi^2}{4}\right]$

$\therefore \cos^{-1}x + (\sin^{-1}y)^2 \in \left[0, \pi + \frac{\pi^2}{4}\right]$

$\Rightarrow 0 \leq \frac{a\pi^2}{4} \leq \pi + \frac{\pi^2}{4} \Rightarrow 0 \leq a \leq \frac{4}{\pi} + 1$

$\Rightarrow a \in \left[0, \frac{4}{\pi} + 1\right]$

11. (c) Equation  $\cos^{-1}x + (\sin^{-1}y)^2 = \frac{a\pi^2}{4}$  is valid for

$a \in \left[0, \frac{4}{\pi} + 1\right]$  .....(i)

Now  $(\cos^{-1}x) \cdot (\sin^{-1}y)^2 = \frac{\pi^4}{16}$

$\Rightarrow (\sin^{-1}y)^2 = \frac{\pi^4}{16(\cos^{-1}x)}$

$\therefore$  From (i),  $(\cos^{-1}x) + \frac{\pi^4}{16(\cos^{-1}x)} = \frac{a\pi^2}{4}$

$\Rightarrow 16(\cos^{-1}x)^2 + \pi^4 = 4a\pi^2\cos^{-1}x$

$\Rightarrow 16(\cos^{-1}x)^2 - 4a\pi^2\cos^{-1}x + \pi^4 = 0$

Let  $\cos^{-1}x = t \in [-1, 1]$

$\Rightarrow 16t^2 - 4a\pi^2t + \pi^4 = 0$

$\Rightarrow$  Roots must be real and lying in  $[-1, 1]$

$\Rightarrow f(-1), f(1) \geq 0$  and  $\text{Disc} \geq 0$

$\Rightarrow 16 + 4a\pi^2 + \pi^4 \geq 0$ ;  $16 - 4a\pi^2 + \pi^4 \geq 0$  and  $16a^2\pi^4 - 64\pi^4 \geq 0$

$\Rightarrow 4a\pi^2 \geq -\pi^4 - 16$ ;  $4a\pi^2 \leq 16 + \pi^4$ ;  $a^2\pi^4 \geq 4\pi^4$

$\Rightarrow a \geq \frac{-\pi^4 - 16}{4\pi^2}$ ;  $a \leq \frac{16 + \pi^4}{4\pi^2}$ ;  $a^2 \geq 4$

$\Rightarrow a \in \left[\frac{-\pi^4 - 16}{4\pi^2}, \frac{16 + \pi^4}{4\pi^2}\right] \cap \{(-\infty, -2] \cup (2, \infty)\} \cap \left[0, \frac{4}{\pi} + 1\right]$

$= \left[2, \frac{4}{\pi} + 1\right]$

12. (a) The equation (i) and (ii) hold for  $a \in \left[2, \frac{4}{\pi} + 1\right] \leq (2, 3]$  having integer value 2.

13. (c) Integer value of  $a = 2$

$\therefore \cos^{-1}x + (\sin^{-1}y)^2 = \frac{\pi^2}{2}$  and  $(\cos^{-1}x)(\sin^{-1}y)^2 = \frac{\pi^2}{16}$

$\Rightarrow (\cos^{-1}x) + \frac{\pi^4}{16\cos^{-1}x} = \frac{\pi^2}{2}$

$\Rightarrow 16t^2 + \pi^4 = 8\pi^2\cos^{-1}x$

$\Rightarrow 16t^2 - 8\pi^2t + \pi^4 = 0$ ;  $t = \cos^{-1}x$

$\Rightarrow t = \frac{8\pi^2 \pm \sqrt{64\pi^4 - 64\pi^4}}{2 \times 16}$

$\Rightarrow t = \frac{8\pi^2}{32} \Rightarrow t = \frac{\pi^2}{4}$

$\therefore \cos^{-1}x = \frac{\pi^2}{4} \Rightarrow x = \cos\left(\frac{\pi^2}{4}\right)$

$\therefore (\sin^{-1}y)^2 = \frac{\pi^4}{16\cos^{-1}x} = \frac{\pi^4}{16\left(\frac{\pi^2}{4}\right)} = \frac{\pi^4}{16} \times \frac{4}{\pi^2} = \frac{\pi^2}{4}$

$\sin^{-1}y = \pm \frac{\pi}{2} \Rightarrow y = \sin^{-1}\left(\pm \frac{\pi}{2}\right) = \pm 1$

$\therefore (x, y) \equiv \left(\cos\left(\frac{\pi^2}{4}\right), \pm 1\right)$

14. (a)  $\cot^{-1}\left[(\cos\alpha)^{1/2}\right] - \tan^{-1}\left[(\cos\alpha)^{1/2}\right] = x$

Let  $(\cos\alpha)^{1/2} = \beta$

$\therefore \cot^{-1}\beta - \tan^{-1}\beta = x$

$\Rightarrow \sin x = \sin[\cot^{-1}\beta - \tan^{-1}\beta]$

$= \sin(\cot^{-1}\beta)\cos(\tan^{-1}\beta) - \cos(\cot^{-1}\beta)\sin(\tan^{-1}\beta)$

$= \sin\left[\sin^{-1}\left(\frac{1}{\sqrt{1+\beta^2}}\right)\right]\cos\left[\cos^{-1}\left(\frac{1}{\sqrt{1+\beta^2}}\right)\right]$

$- \cos\left[\cos^{-1}\left(\frac{\beta}{\sqrt{1+\beta^2}}\right)\right]\sin\left[\sin^{-1}\left(\frac{\beta}{\sqrt{1+\beta^2}}\right)\right]$

$$\begin{aligned}
 &= \frac{1}{\sqrt{1+\beta^2}} \times \frac{1}{\sqrt{1+\beta^2}} - \frac{\beta}{\sqrt{1+\beta^2}} \times \frac{\beta}{\sqrt{1+\beta^2}} \\
 &= \left( \frac{1-\beta^2}{1+\beta^2} \right) = \frac{1-\cos\alpha}{1+\cos\alpha} = \tan^2 \frac{\alpha}{2}
 \end{aligned}$$

**Passage D:**

$$\begin{aligned}
 15. \text{ (d)} \quad &\cos(\tan^{-1}(\tan 4)); 4 \in \left( \pi, \frac{3\pi}{2} \right) \\
 &= \cos[\tan^{-1}(\tan(\pi + \theta))]; \text{ where } 4 = \pi + \theta \\
 &= \cos[\tan^{-1}(\tan \theta)]; \theta = 4 - \pi \in \left( 0, \frac{\pi}{2} \right) \\
 &= \cos\theta; \text{ since } \tan^{-1}(\tan x) = x \quad \forall x \in \left( -\frac{\pi}{2}, \frac{\pi}{2} \right) \\
 &= \cos(4 - \pi) = \cos(\pi - 4) = -\cos 4
 \end{aligned}$$

16. (d) Given  $x \in [-1, 0)$  is negative possible value for  $\sin^{-1}x$

$$\begin{aligned}
 &\text{Let } \sin^{-1}x = \theta; x \in [-1, 0); \theta \in \left[ -\frac{\pi}{2}, 0 \right) \\
 \Rightarrow \sin\theta &= x \quad \Rightarrow \cos\theta = \sqrt{1 - \sin^2\theta} \\
 &\left( \because \theta \in \left[ -\frac{\pi}{2}, 0 \right) \text{ for which } \cos\theta \geq 0 \right) \\
 \Rightarrow \cos\theta &= \sqrt{1 - x^2} \quad \Rightarrow \cos^{-1}(\cos\theta) = \cos^{-1}\sqrt{1 - x^2} \\
 \Rightarrow \cos^{-1}(\cos(-\theta)) &= \cos^{-1}\sqrt{1 - x^2} \quad (\because \cos(-x) = \cos x) \\
 \Rightarrow -\theta &= -\cos^{-1}\sqrt{1 - x^2} \text{ as } -\theta \in \left( 0, \frac{\pi}{2} \right] \subset [0, \pi] \\
 \Rightarrow \theta &= -\cos^{-1}\sqrt{1 - x^2} \\
 \Rightarrow \sin^{-1}x &= -\cos^{-1}\sqrt{1 - x^2} = -\left[ \cot^{-1}\left( \frac{\sqrt{1 - x^2}}{-x} \right) \right] \\
 &= -\left[ \pi - \cot^{-1}\left( \frac{\sqrt{1 - x^2}}{x} \right) \right] \quad (\because \cot^{-1}(-x) = \pi - \cot^{-1}x) \\
 &= -\pi + \cot^{-1}\left( \frac{\sqrt{1 - x^2}}{x} \right)
 \end{aligned}$$

$$\begin{aligned}
 17. \text{ (d)} \quad &\text{Given } \frac{3\pi}{2} \leq x \leq \frac{5\pi}{2} \\
 \sin^{-1}(\sin x) &= \sin^{-1}[\sin(2\pi + \theta)]; \theta \in \left[ -\frac{\pi}{2}, \frac{\pi}{2} \right]; x = 2\pi + \theta \\
 &= \sin^{-1}[\sin\theta]; \theta \in \left[ -\frac{\pi}{2}, \frac{\pi}{2} \right] = \theta = x - 2\pi
 \end{aligned}$$

18. (c) Given  $x > 1$

$$2\tan^{-1}x + \sin^{-1}\left(\frac{2x}{1+x^2}\right) \quad \dots(i)$$

$$\text{We know that, } 2\tan^{-1}x = \begin{cases} \sin^{-1}\left(\frac{2x}{1+x^2}\right) \text{ for } f \leq x \leq 1 \\ -\pi - \sin^{-1}\left(\frac{2x}{1+x^2}\right) \text{ for } x < -1 \\ \pi - \sin^{-1}\left(\frac{2x}{1+x^2}\right) \text{ for } x > 1 \end{cases}$$

$$\therefore \text{ For } x > 1; \sin^{-1}\left(\frac{2x}{1+x^2}\right) = \pi - 2\tan^{-1}x$$

$$\therefore \text{ From (i) required expression} = 2\tan^{-1}x + \pi - 2\tan^{-1}x = \pi.$$

$$19. \text{ (c) Let } y = \left( \frac{1+x}{1-x} \right) \Rightarrow y - xy = 1 + x$$

$$\Rightarrow y - 1 = x(1 + y) \Rightarrow x = \frac{y-1}{y+1}$$

$$\text{Now } 0 \leq x \leq 1$$

$$\Rightarrow x \in [0, 1) \text{ as } 1 \notin \text{Domain of } \left( \frac{1+x}{1-x} \right)$$

$$\Rightarrow 0 \leq \frac{y-1}{y+1} < 1 \Rightarrow \frac{y-1}{y+1} \geq 0 \text{ and } \frac{-2}{y+1} < 0$$

$$\Rightarrow (y-1)(y+1) \geq 0; y \neq -1 \text{ and } y+1 > 0$$

$$\Rightarrow y \in (-\infty, -1) \cup [1, \infty) \text{ and } y > -1$$

$$\Rightarrow y \in [1, \infty)$$

$$\text{Thus } \left( \frac{1+x}{1-x} \right) \in [1, \infty)$$

$$\Rightarrow \tan^{-1}\theta \text{ is an increasing function for } \theta \in [1, \infty)$$

$$\Rightarrow \text{Least value} = \tan^{-1}1 = \pi/4 \text{ and greatest limiting value} = \tan^{-1}\infty = \pi/2$$

**Passage E:**

$$\begin{aligned}
 20. \text{ (a) } &\tan^{-1}\left(\frac{1}{3}\right) + \tan^{-1}\left(\frac{2}{9}\right) + \dots + \tan^{-1}\left(\frac{2^{n-1}}{1+2^{2n-1}}\right) \\
 &= \tan^{-1}\left(\frac{2-1}{1+1.2}\right) + \tan^{-1}\left(\frac{4-2}{1+2.4}\right) + \dots + \tan^{-1}\left(\frac{2^n - 2^{n-1}}{1+2^n.2^{n-1}}\right) \\
 &= (\tan^{-1}2 - \tan^{-1}1) + (\tan^{-1}4 - \tan^{-1}2) + \dots + (\tan^{-1}2^n - \tan^{-1}2^{n-1}) \\
 &= \tan^{-1}2^n - \tan^{-1}1
 \end{aligned}$$

$$\text{For limit } n \rightarrow \infty, \text{ sum} \rightarrow \tan^{-1}\infty - \tan^{-1}1 \rightarrow \frac{\pi}{2} - \frac{\pi}{4} = \frac{\pi}{4}$$

$$21. \text{ (d) } \operatorname{cosec}^{-1}\sqrt{5} + \operatorname{cosec}^{-1}\sqrt{65} + \operatorname{cosec}^{-1}\sqrt{325} + \dots \text{ to } \infty$$

$$= \lim_{x \rightarrow \infty} \left[ \tan^{-1}\left(\frac{1}{2}\right) + \tan^{-1}\left(\frac{1}{8}\right) + \tan^{-1}\left(\frac{1}{18}\right) + \dots + n^{\text{th}} \text{ term} \right]$$

$$= \lim_{x \rightarrow \infty} \left[ \tan^{-1}\left(\frac{3-1}{1+1.3}\right) + \tan^{-1}\left(\frac{5-3}{1+3.5}\right) + \tan^{-1}\left(\frac{7-5}{1+5.7}\right) + \dots + \tan^{-1}\left(\frac{2n+1-(2n-1)}{1+(2n-1)(2n+1)}\right) \right]$$

$$= \lim_{x \rightarrow \infty} [\tan^{-1}(2n+1) - \tan^{-1}1] = \frac{\pi}{2} - \frac{\pi}{4} = \frac{\pi}{4}$$

$$22. \text{ (c) } s_n = \cot^{-1}\left(2^2 + \frac{1}{2}\right) + \cot^{-1}\left(2^3 + \frac{1}{2^2}\right) +$$

$$\cot^{-1}\left(2^4 + \frac{1}{2^3}\right) + \dots + \cot^{-1}\left(2^{n+1} + \frac{1}{2^n}\right)$$

$$= \tan^{-1}\left(\frac{2}{1+2.2^2}\right) + \tan^{-1}\left(\frac{2^2}{1+2^2.2^3}\right) +$$

$$\tan^{-1}\left(\frac{2^3}{1+2^3.2^4}\right) + \dots + \tan^{-1}\left(\frac{2^n}{1+2^n.2^{n+1}}\right)$$

4.134 > Trigonometry

$$\begin{aligned}
 &= \tan^{-1}\left(\frac{2^2-2}{1+2\cdot 2^2}\right) + \tan^{-1}\left(\frac{2^3-2^2}{1+2^2\cdot 2^3}\right) + \\
 &\quad \tan^{-1}\left(\frac{2^4-2^3}{1+2^3\cdot 2^4}\right) + \dots + \tan^{-1}\left(\frac{2^{n+1}-2^n}{1+2^n\cdot 2^{n+1}}\right) \\
 &= \tan^{-1}(2^{n+1}) - \tan^{-1}(2) = \cot^{-1}2 \\
 \therefore S_\infty &= \frac{\pi}{2} - \tan^{-1}(2) = \cot^{-1}2
 \end{aligned}$$

23. (d)  $S_n = \cot^{-1}3 + \cot^{-1}7 + \cot^{-1}13 + \dots + n^{\text{th}} \text{ term}$   
 $= \tan^{-1}(1/3) + \tan^{-1}(1/7) + \tan^{-1}(1/13) + \dots + (\text{upto } n^{\text{th}} \text{ term})$   
 $= \tan^{-1}\left(\frac{2-1}{1+1\cdot 2}\right) + \tan^{-1}\left(\frac{3-2}{1+2\cdot 3}\right) + \tan^{-1}\left(\frac{4-3}{1+3\cdot 4}\right)$   
 $+ \dots + \tan^{-1}\left(\frac{(n+1)-n}{1+n(n+1)}\right) = \tan^{-1}(n+1) - \tan^{-1}1$   
 $\therefore S_\infty = \frac{\pi}{2} - \frac{\pi}{4} = \frac{\pi}{4}$

24. (b)  $S_n = \tan^{-1}\left(\frac{2}{1-1^2+1^4}\right) + \tan^{-1}\left(\frac{4}{1-2^2+2^4}\right) +$   
 $\tan^{-1}\left(\frac{6}{1-3^2+3^4}\right) + \dots + \text{upto } (n^{\text{th}} \text{ terms})$   
 $= \sum_{r=1}^n \tan^{-1}\left(\frac{2r}{1-r^2+r^4}\right) = \sum_{r=1}^n \tan^{-1}\left[\frac{2r}{1+r^2(r^2-1)}\right]$   
 $= \sum_{r=1}^n \tan^{-1}\left[\frac{2r}{1+r(r-1)r(r+1)}\right]$   
 $= \sum_{r=1}^n \tan^{-1}\left[\frac{r(r+1)-r(r-1)}{1+r(r+1)r(r-1)}\right]$   
 $= \sum_{r=1}^n \left[\tan^{-1}r(r+1) - \tan^{-1}r(r-1)\right]$   
 $= \tan^{-1}n(n+1) - \tan^{-1}1. (0) = \tan^{-1}n(n+1)$   
 $\Rightarrow S_\infty \rightarrow \tan^{-1}\infty = \pi/2$

Passage F:

25. (a)  $\alpha + \beta = \cos^{-1}\left(\frac{4}{5}\right) + \tan^{-1}\left(\frac{2}{3}\right)$   
 $= \tan^{-1}\left(\frac{3}{4}\right) + \tan^{-1}\left(\frac{2}{3}\right) = \tan^{-1}\left(\frac{\frac{3}{4} + \frac{2}{3}}{1 - \frac{3}{4} \times \frac{2}{3}}\right) = \tan^{-1}\left(\frac{17}{6}\right)$

26. (b)  $\alpha - \beta = \cos^{-1}\left(\frac{4}{5}\right) - \tan^{-1}\left(\frac{2}{3}\right) = \tan^{-1}\left(\frac{3}{4}\right) - \tan^{-1}\left(\frac{2}{3}\right)$   
 $= \tan^{-1}\left[\frac{\frac{3}{4} - \frac{2}{3}}{1 + \frac{3}{4} \times \frac{2}{3}}\right] = \tan^{-1}\left[\frac{1}{18}\right]$

27. (a)  $2a = 2\cos^{-1}\left(\frac{4}{5}\right)$   
 $\Rightarrow \cos^{-1}\left(\frac{4}{5}\right) = \alpha \in \left(0, \frac{\pi}{2}\right) \Rightarrow 2\alpha \in (0, \pi)$

$$\begin{aligned}
 \Rightarrow \cos \alpha &= \frac{4}{5} \Rightarrow \sec \alpha = \frac{5}{4} \Rightarrow \tan \alpha = \frac{3}{4} \\
 \therefore \tan 2\alpha &= \left(\frac{2 \tan \alpha}{1 - \tan^2 \alpha}\right) = \left(\frac{3/2}{1 - 9/16}\right) = \left(\frac{3}{2} \times \frac{16}{7}\right) = \frac{24}{7} > 0 \\
 \Rightarrow 2\alpha &\in \left(0, \frac{\pi}{2}\right) = 2\alpha = \tan^{-1}\left(\frac{24}{7}\right)
 \end{aligned}$$

SECTION-VII (MATRIX MATCH TYPE ANSWERS)

1. (i)  $\rightarrow$  (a); (ii)  $\rightarrow$  (c); (iii)  $\rightarrow$  (b)
- (i)  $\left(\tan^{-1} \frac{x}{3}\right)^2 - 4 \tan^{-1} \frac{x}{3} - 5 = 0$   
 $\Rightarrow t^2 - 4t - 5 = 0; t = \tan^{-1} x/3$   
 $\Rightarrow (t-5)(t+1) = 0$   
 $\Rightarrow t = 5 \text{ or } t = -1 \Rightarrow \tan^{-1}\left(\frac{x}{3}\right) = 5 \text{ or } -1$   
 $\Rightarrow \tan 5 = \frac{x}{3} \text{ or } \tan(-1) = \frac{x}{3} \quad (\because \tan(\tan^{-1}x) = x \forall x \in \mathbb{R})$   
 $\Rightarrow x = 3 \tan 5 \text{ or } x = -3 \tan 1$
- (ii)  $[\tan^{-1}(3x+2)]^2 + 2 \tan^{-1}(3x+2) = 0$   
 $\Rightarrow t^2 + 2t = 0; t = \tan^{-1}(3x+2)$   
 $\Rightarrow t = 0 \text{ or } t = -2$   
 $\Rightarrow \tan^{-1}(3x+2) = 0 \text{ or } \tan^{-1}(3x+2) = -2$   
 $\Rightarrow 3x+2 = 0 \text{ or } 3x+2 = \tan(-2)$   
 $\Rightarrow x = -2/3 \text{ or } x = \frac{-(\tan 2 + 2)}{3}$
- (iii)  $3(\tan^{-1}x)^2 - 4\pi \tan^{-1}x + \pi^2 = 0$   
 $\Rightarrow 3t^2 - 4\pi t + \pi^2 = 0; t = \tan^{-1}x$   
 $\Rightarrow 3t^2 - 3\pi t - \pi t + \pi^2 = 0$   
 $\Rightarrow 3t(t - \pi) - \pi(t - \pi) = 0$   
 $\Rightarrow (3t - \pi)(t - \pi) = 0 \Rightarrow t = \pi/3 \text{ or } t = \pi$   
 $\Rightarrow \tan^{-1}x = \pi/3 \text{ or } \tan^{-1}x = \pi \text{ (impossible)}$   
 $\Rightarrow x = \sqrt{3}$
2. (i)  $\rightarrow$  (b, c); (ii)  $\rightarrow$  (d, e); (iii)  $\rightarrow$  (a, d, e)
- (i)  $\tan^{-1}x + \tan^{-1}y + \tan^{-1}z = \pi$ . Let  $\tan^{-1}x = \theta, \tan^{-1}y + \tan^{-1}z = \theta_3$   
 $\Rightarrow \theta_1 + \theta_2 + \theta_3 = \pi \Rightarrow \theta_1 + \theta_2 = \pi - \theta_3$   
 $\Rightarrow \frac{\tan(\theta_1 + \theta_2)}{1 - \tan \theta_1 \tan \theta_2} = -\tan \theta_3$   
 $\Rightarrow \frac{\tan \theta_1 + \tan \theta_2}{1 - \tan \theta_1 \tan \theta_2} = -\tan \theta_3$   
 $\Rightarrow \tan \theta_1 + \tan \theta_2 + \tan \theta_3 = \tan \theta_1 \tan \theta_2 \tan \theta_3$   
 $\Rightarrow x + y + z = xyz$   
 All  $x, y, z < 0$   
 $\Rightarrow \tan^{-1}x, \tan^{-1}y, \tan^{-1}z < 0$   
 $\Rightarrow \tan^{-1}x, \tan^{-1}y + \tan^{-1}z < 0$   
 But  $\Sigma \tan^{-1}x = \pi \Rightarrow x, y, z$  all can't be negative.  
 If any two of  $x, y, z < 0$  say  $x, y < 0$  and  $z > 0$   
 $\Rightarrow \tan^{-1}x, \tan^{-1}y < 0$  and  $\tan^{-1}z > 0$   
 $\Rightarrow \tan^{-1}x + \tan^{-1}y + \tan^{-1}z < 0 + 0 + \pi/2 = \pi/2$   
 But  $\Sigma \tan^{-1}x = \pi$ , so no two of  $x, y, z$  can be negative  
 If any one of  $x, y, z$  is negative say  $x < 0, y, z > 0$   
 $\Rightarrow \tan^{-1}x < 0, \tan^{-1}y \in (0, \pi/2); \tan^{-1}z \in (0, \pi/2)$   
 $\Rightarrow \tan^{-1}x + \tan^{-1}y + \tan^{-1}z \in \left(-\frac{\pi}{2}, \pi\right)$

$\Rightarrow \tan^{-1}x + \tan^{-1}y + \tan^{-1}z < \pi$   
 $\Rightarrow$  All  $x, y, z$  are non-negative.

Thus by A.M. G.M. inequality,  $x + y + z \geq 3(x.y.z)^{1/3}$

$$\begin{aligned} \Rightarrow xyz &\geq 3(x.y.z)^{1/3} \\ \Rightarrow (xyz)^{1/3} &\geq 3 &\Rightarrow (xyz)^{2/3} &\geq 3 \\ \Rightarrow xyz &\geq (3)^{3/2} = 3\sqrt{3} \end{aligned}$$

(ii)  $\tan^{-1}x + \tan^{-1}y + \tan^{-1}z = \pi/2$ . Let  $\tan^{-1}x = \theta_1, \tan^{-1}y = \theta_2, \tan^{-1}z = \theta_3$

$$\begin{aligned} \Rightarrow \theta_1 + \theta_2 + \theta_3 &= \pi/2 \\ \Rightarrow \theta_1 + \theta_2 &= \pi/2 - \theta_3 \\ \Rightarrow \tan(\theta_1 + \theta_2) &= \cot\theta_3 \\ \Rightarrow \frac{\tan\theta_1 + \tan\theta_2}{1 - \tan\theta_1 \tan\theta_2} &= \frac{1}{\tan\theta_3} \end{aligned}$$

$$\Rightarrow \sum \tan\theta_i \tan\theta_j = 1$$

$$\Rightarrow xy + yz + zx = 1$$

If  $x, y, z < 0$ , then  $\sum \tan^{-1}x < 0$ ; but  $\sum \tan^{-1} = \pi/2$ .

If any two of  $x, y, z$  is negative, say  $x, y < 0; z > 0$ , then  $\tan^{-1}x + \tan^{-1}y + \tan^{-1}z < \pi/2$ , but  $\sum \tan^{-1} = \pi/2$ .

If any one of  $x, y, z$  is negative say  $x < 0, y, z > 0$  then,  $x.y.z < 0$

$$\Rightarrow x.y.z < \frac{1}{3\sqrt{3}}$$

So Let  $x, y, z$  are non-negative

$\therefore$  by A.M.  $\geq$  GM, for  $xy, yz$  and  $zx$   
 $xy + yz + zx \geq 3(x^2y^2z^2)^{1/3}$

$$\Rightarrow 1 \geq 3(xyz)^{2/3} \quad \Rightarrow (xyz)^{2/3} \leq 1/3$$

$$\Rightarrow xyz \leq \frac{1}{3\sqrt{3}}$$

(iii)  $\tan^{-1}x + \tan^{-1}y + \tan^{-1}z = \pi/2$  .....(i) and  
 $x + y + z = \sqrt{3}$  .....(ii)

From (i),  $\theta_1 + \theta_2 + \theta_3 = \pi/2$

$$\Rightarrow xy + yz + zx = 1 \quad \dots\dots\dots\text{(iii)}$$

(By part (ii))

$$\text{Now } x^2 + y^2 + z^2 = (x + y + z)^2 - 2(xy + yz + zx) = 3 - 2(1) = 1$$

$$\text{Also } (x - y)^2 + (y - z)^2 + (z - x)^2 = 2[x^2 + y^2 + z^2 - xy - yz - zx] = 2[1 - 1] = 0$$

$$\Rightarrow x = y = z = \frac{\sqrt{3}}{3} = \frac{1}{\sqrt{3}}$$

$$\Rightarrow x.y.z = \frac{1}{3\sqrt{3}} \quad \Rightarrow \text{(a), (d) are true}$$

$$\text{Also } xy + yz + zx = \left(\frac{1}{\sqrt{3}}\right)^2 + \left(\frac{1}{\sqrt{3}}\right)^2 + \left(\frac{1}{\sqrt{3}}\right)^2 = 1$$

3. (i)  $\rightarrow$  (b, e); (ii)  $\rightarrow$  (a, d); (iii)  $\rightarrow$  (b, c)

(i)  $\sin^{-1}\left(-\frac{1}{2}\right) + \tan^{-1}(\sqrt{3}) = \frac{-\pi}{6} + \frac{\pi}{3} = \frac{\pi}{6} = \lambda$  (given) and

$$\cos^{-1}\left(-\frac{1}{2}\right) = \frac{3\pi}{4} = \mu \text{ (given)}$$

$$\Rightarrow \lambda + \mu = \frac{\pi}{6} + \frac{3\pi}{4} = \frac{\pi + 4\pi}{6} = \frac{5\pi}{6}$$

$$\text{and } 1 - m = \frac{\pi}{6} - \frac{2\pi}{3} = \frac{-\pi}{2} \Rightarrow \mu - \lambda = \frac{\pi}{2}$$

(ii)  $\sin^{-1}\left(\sin\frac{7\pi}{6}\right) = \lambda; \cos^{-1}\left(-\sin\left(\frac{5\pi}{6}\right)\right) = \mu$

$$\Rightarrow \sin^{-1}\left(\sin\left(\pi + \frac{\pi}{6}\right)\right) = \lambda; \cos^{-1}\left(-\sin\left(\pi - \frac{\pi}{6}\right)\right) = \mu$$

$$\Rightarrow \sin^{-1}\left(-\sin\frac{\pi}{6}\right) = \lambda; \cos^{-1}\left(-\sin\frac{\pi}{6}\right) = \mu$$

$$\Rightarrow -\frac{\pi}{6} = \lambda; \cos^{-1}\left(-\frac{1}{2}\right) = \mu$$

$$\Rightarrow \lambda = \frac{-\pi}{6}; \mu = \frac{2\pi}{3} \quad \Rightarrow 1 + m = \pi/2; m - 1 = 5\pi/6$$

(iii)  $\sin^{-1}\left(-\frac{\sqrt{3}}{2}\right) = \lambda; \sin^{-1}\left(\cos\left(\sin^{-1}\left(\frac{\sqrt{3}}{2}\right)\right)\right) = \mu$

$$\Rightarrow -\frac{\pi}{3} = \lambda; \sin^{-1}\left[\cos\left(\frac{\pi}{3}\right)\right] = \mu$$

$$\Rightarrow 1 = \pi/3; m = \pi/6 \quad \Rightarrow 1 + m = -\pi/6; m - 1 = \pi/2$$

4. (i)  $\rightarrow$  (b, c); (ii)  $\rightarrow$  (c, d, e); (iii)  $\rightarrow$  (a, c)

(i)  $2\tan^{-1}(2x + 1) = \cos^{-1}(-x)$

$$\Rightarrow \cos^{-1}\left[\frac{1 - (2x + 1)^2}{1 + (2x + 1)^2}\right] = \cos^{-1}(-x); \text{ for } (2x + 1) \geq 1$$

$$\text{And } -\cos^{-1}\left[\frac{1 - (2x + 1)^2}{1 + (2x + 1)^2}\right] = \cos^{-1}(-x) \text{ for } (2x + 1) < 0$$

L.H.S  $\leq 0$  and R.H.S  $\geq 0$

$\Rightarrow$  Equality holds for both sides equal to zero

$$\Rightarrow \frac{1 - (2x + 1)^2}{1 + (2x + 1)^2} = -x \text{ for } 2x + 1 \geq 0 \text{ and } \frac{1 - (2x + 1)^2}{1 + (2x + 1)^2} = 1$$

and  $x = -1$  for  $x < -1/2$  (impossible)

$$\Rightarrow 1 - (2x + 1)^2 = -x - x(2x + 1)^2 \text{ for } x \geq -1/2$$

$$\Rightarrow (x - 1)(2x + 1)^2 = -x - 1; x \geq -1/2$$

$$\Rightarrow x = 0 \text{ or } x = \pm\frac{1}{\sqrt{2}} \quad \Rightarrow x = 0, x = \frac{1}{\sqrt{2}}$$

(ii)  $2\cos^{-1}x = \sin^{-1}\left(2x\sqrt{1 - x^2}\right)$  .....(i)

$$\sin^{-1}\left(2x\sqrt{1 - x^2}\right) \in \left[-\frac{\pi}{2}, \frac{\pi}{2}\right]; \text{ whereas } 2\cos^{-1}x \in [0, 2\pi]$$

$\therefore$  For equality (1) to hold, both must belong to  $\left[0, \frac{\pi}{2}\right]$

$$\Rightarrow \cos^{-1}x \in \left[0, \frac{\pi}{4}\right] \quad \Rightarrow x \in \left[\frac{1}{\sqrt{2}}, 1\right]$$

$$\text{Let } x = \cos\theta; \theta \in \left[0, \frac{\pi}{4}\right]$$

$$\Rightarrow \sin\theta = \sqrt{1 - x^2}$$

$$\therefore \text{R.H.S.} = 2\cos^{-1}x; \text{ Also L.H.S.} = 2\cos^{-1}x$$

$$\therefore \text{Both are same for } x \in \left[\frac{1}{\sqrt{2}}, 1\right]$$

(iii)  $\tan^{-1}\left(\frac{x-1}{x-2}\right) + \tan^{-1}\left(\frac{x+1}{x+2}\right) = \frac{\pi}{4}$

$$\frac{(x-1)}{(x-2)} \times \frac{(x+1)}{(x+2)} = \frac{x^2-1}{x^2-4} < 1 \text{ for } \frac{x^2-1-x^2+4}{x^2-4} < 0 \text{ i.e.,}$$

$$x^2 - 4 < 0 \text{ i.e., } x \in (-2, 2)$$

And  $\frac{x^2-1}{x^2-4} > 1$  for  $x^2-4 > 0$  i.e.,  $x \in (-\infty, -2) \cup (2, \infty)$

and  $\frac{x^2-1}{x^2-4} \neq 1$

$$\therefore \tan^{-1} \left( \frac{\frac{x-1}{x-2} + \frac{x+1}{x+2}}{1 - \left(\frac{x-1}{x-2}\right)\left(\frac{x+1}{x+2}\right)} \right) = \frac{\pi}{4} \text{ for } x \in (-2, 2) \text{ and}$$

$$\pi + \tan^{-1} \left( \frac{\frac{x-1}{x-2} + \frac{x+1}{x+2}}{1 - \frac{(x^2-1)}{(x^2-4)}} \right) = \frac{\pi}{4} \text{ for } x \in (-\infty, -2) \cup (2, \infty)$$

and  $(x-1)(x-2); (x+1)(x+2) > 0$  as  $\frac{x-1}{x-2}, \frac{x+1}{x+2} < 0$

$\Rightarrow \tan^{-1} \left( \frac{x-1}{x-2} \right) + \tan^{-1} \left( \frac{x+1}{x+2} \right) < 0$ , which is contrary to given equation.

Thus  $\tan^{-1} \left( \frac{2x^2-4}{-3} \right) = \frac{\pi}{4}$ ;  $x \in (-2, 2)$  and

$$\pi + \tan^{-1} \left( \frac{2x^2-4}{-3} \right) = \frac{\pi}{4}; x \in (-\infty, -2) \cup (2, \infty)$$

$$\Rightarrow \frac{2x^2-4}{-3} = 1 \text{ for } x \in (-2, 2) \text{ and } \tan^{-1} \left( \frac{2x^2-4}{3} \right) = \frac{3\pi}{4}$$

for  $x \in (-\infty, -2) \cup (2, \infty)$  (impossible)

$$\Rightarrow 2x^2-1 = 0 \text{ for } x \in (-2, 2)$$

$$\Rightarrow x = \pm 1/\sqrt{2}$$

5. (i)  $\rightarrow$  (a, c); (ii)  $\rightarrow$  (b); (iii)  $\rightarrow$  (a); (iv)  $\rightarrow$  (d)

$$\sin^{-1}(ax) + \cos^{-1}(y) + \cos^{-1}(bxy) = \frac{\pi}{2} \text{ (given)}$$

(i) For  $a=1, b=0, \sin^{-1}x + \cos^{-1}y = \pi/2$ , But  $\sin^{-1}x + \cos^{-1}x = \pi/2$

$$\Rightarrow \cos^{-1}y = \cos^{-1}x \Rightarrow x = y$$

$$\Rightarrow 2\sin^{-1}x = \pi/2 \Rightarrow \sin^{-1}x = \pi/4$$

$$\Rightarrow x = 1/\sqrt{2} = y \Rightarrow x^2 + y^2 = 1$$

$$\Rightarrow (x^2-1)(y^2-1) = \left(-\frac{1}{2}\right)\left(\frac{1}{2}\right) \neq 0$$

$$\text{and } (4x^2-1)(y^2-1) = (1)(1/2) \neq 0$$

(ii) For  $a=1, b=1, \sin^{-1}x + \cos^{-1}y + \cos^{-1}xy = \pi/2$

$$\Rightarrow \sin^{-1}x - \sin^{-1}y = -\cos^{-1}xy$$

$$\Rightarrow \sin^{-1}y - \sin^{-1}x = \cos^{-1}xy \quad \dots (i)$$

Now  $-\frac{\pi}{2} \leq \sin^{-1}y - \sin^{-1}x \leq \frac{\pi}{2}$  and  $\cos^{-1}xy \in [0, \pi]$ ,

but for (i) to hold, both sides must belong to  $[0, \pi/2]$

$$\Rightarrow \cos^{-1}(\cos(\sin^{-1}y - \sin^{-1}x)) = \cos^{-1}xy$$

$$\Rightarrow \sqrt{1-y^2}\sqrt{1-x^2} + yx = xy$$

$$\Rightarrow \sqrt{1-x^2}\sqrt{1-y^2} = 0 \Rightarrow (1-x^2)(1-y^2) = 0$$

(iii) For  $a=1, b=2; \sin^{-1}x + \cos^{-1}y + \cos^{-1}(2xy) = \pi/2$

$$\Rightarrow \sin^{-1}x - \left(\frac{\pi}{2} - \cos^{-1}y\right) = -\cos^{-1}(2xy)$$

$$\Rightarrow \sin^{-1}x - \sin^{-1}y = \cos^{-1}(2xy)$$

$$\Rightarrow \sin^{-1}y - \sin^{-1}x = \cos^{-1}(2xy)$$

As above  $\cos^{-1}xy$  and  $\sin^{-1}y - \sin^{-1}x \in [0, \pi/2]$

$$\therefore \cos^{-1}(\cos(\sin^{-1}y - \sin^{-1}x)) = \cos^{-1}(2xy)$$

$$\Rightarrow \sqrt{1-y^2}\sqrt{1-x^2} + yx = 2xy$$

$$\Rightarrow \sqrt{1-x^2}\sqrt{1-y^2} = xy$$

$$\Rightarrow (1-x^2)(1-y^2) = x^2 \Rightarrow x^2 + y^2 = 1$$

(iv) For  $a=2, b=2, \sin^{-1}(2x) + \cos^{-1}y + \cos^{-1}(2xy) = \pi/2$

$$\Rightarrow \sin^{-1}2x - \left(\frac{\pi}{2} - \cos^{-1}y\right) = -\cos^{-1}(2xy)$$

$$\Rightarrow \sin^{-1}y - \sin^{-1}2x = \cos^{-1}(2xy)$$

$$\Rightarrow \sin^{-1}y > \sin^{-1}2x \Rightarrow y > 2x$$

$$\text{Also } -\frac{\pi}{2} \leq \sin^{-1}y - \sin^{-1}2x \leq \frac{\pi}{2}$$

$$\Rightarrow \sin^{-1}y - \sin^{-1}2x \text{ and } \cos^{-1}(2xy) \in [0, -]$$

$$\therefore \cos^{-1}(\cos(\sin^{-1}y - \sin^{-1}2x)) = \cos^{-1}(2xy)$$

$$\Rightarrow \sqrt{1-y^2}\sqrt{1-4x^2} + y(2x) = 2xy$$

$$\Rightarrow (1-y^2)(1-4x^2) = 0 \text{ or } (4x^2-1)(y^2-1) = 0$$

### SECTION-VIII (INTEGER TYPE ANSWERS)

$$1. \sin^{-1} \left[ \cos \left( \tan^{-1} \frac{1}{3} + \tan^{-1} \frac{1}{2} \right) \right] = \frac{\pi}{k} \text{ (given)}$$

$$\Rightarrow \sin^{-1} \left[ \cos \left( \tan^{-1} \left( \frac{\frac{1}{3} + \frac{1}{2}}{1 - \frac{1}{3} \cdot \frac{1}{2}} \right) \right) \right] = \frac{\pi}{k}$$

$$\Rightarrow \sin^{-1} \left[ \cos \left( \tan^{-1} \left( \frac{\frac{5}{6}}{\frac{5}{6}} \right) \right) \right] = \frac{\pi}{k}$$

$$\Rightarrow \sin^{-1} \left[ \cos \frac{\pi}{4} \right] = \frac{\pi}{k} \Rightarrow \frac{\pi}{4} = \frac{\pi}{k} \Rightarrow k = 4$$

$$2. \tan \left\{ \cos^{-1} \frac{4}{5} + \tan^{-1} \frac{2}{5} \right\} = \frac{\lambda}{\mu}; (\lambda, \mu) = 1 \text{ (g.c.d.)}$$

$$\Rightarrow \tan \left\{ \tan^{-1} \left( \frac{3}{4} \right) + \tan^{-1} \left( \frac{2}{5} \right) \right\} = \frac{\lambda}{\mu}$$

$$\Rightarrow \tan \left\{ \tan^{-1} \left( \frac{\frac{3}{4} + \frac{2}{5}}{1 - \frac{3}{4} \times \frac{2}{5}} \right) \right\} = \frac{\lambda}{\mu}$$

$$\Rightarrow \tan \left\{ \tan^{-1} \left( \frac{23}{14} \right) \right\} = \frac{\lambda}{\mu}$$

$$\Rightarrow \frac{23}{14} = \frac{\lambda}{\mu} \quad (\because \tan(\tan^{-1}x) = x \forall x \in \mathbb{R})$$

$$\Rightarrow \lambda = 23, \mu = 14 \quad \therefore \frac{\lambda+19}{\mu} = \frac{23+19}{14} = \frac{42}{14} = 3$$

$$3. \theta = \pi - \left( \tan^{-1} \frac{1}{2} + \tan^{-1} \frac{1}{3} \right)$$

$$= \pi - \left[ \tan^{-1} \left( \frac{\frac{1}{2} + \frac{1}{3}}{1 - \frac{1}{2} \times \frac{1}{3}} \right) \right] = \pi - \tan^{-1} \left( \frac{\frac{5}{6}}{\frac{5}{6}} \right) = \pi - \frac{\pi}{4} = \frac{3\pi}{4}$$

$$\Rightarrow \frac{\theta}{15} = \frac{3\pi}{4 \times 15} = \frac{\pi}{20} = 9 \text{ (in degrees)}$$

4. If  $\cos^{-1} \sqrt{x-1} = \sin^{-1} \sqrt{2-x} \forall x \in [a, b]$ , we know that  $\cos^{-1} x = \sin^{-1} \sqrt{1-x^2}$  for  $[0, 1]$

$$\therefore \cos^{-1} \sqrt{x-1} = \sin^{-1} \sqrt{2-x} = \sin^{-1} \sqrt{1 - (\sqrt{x-1})^2}$$

$$\Rightarrow \sqrt{x-1} \in [0, 1]; x \geq 1 \Rightarrow (x-1) \in [0, 1]$$

$$\Rightarrow x \in [1, 2] = [a, b] \text{ (given)}$$

$$\Rightarrow a + b = 3$$

5. Area enclosed by  $y = \sin x$  and  $y = \sin^{-1}(\sin x) \forall x \in [-2\pi, 2\pi] = \pi^2 - k$

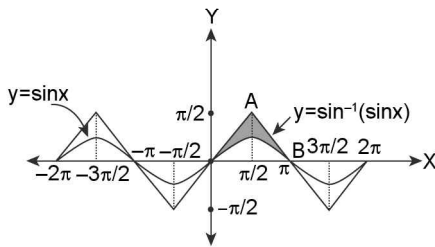

Area enclosed = 4 (area enclosed between  $y = \sin x$  and  $y = \sin^{-1}(\sin x)$  in  $x \in [0, \pi]$ )

$$= 4 \left[ \text{Area of } \triangle OAB - \int_0^{\pi} \sin x \, dx \right]$$

$$= 4 \left[ \frac{1}{2} (\pi) \times \frac{\pi}{2} + [\cos x]_0^{\pi} \right]$$

$$= 4 \left[ \frac{\pi^2}{4} + (-1-1) \right] = \pi^2 - 8 = \pi^2 - k \text{ (given)}$$

$$k = 8$$

6.  $3\sin^{-1}x = -\pi - \sin^{-1}(3x - 4x^3) \dots (i)$

has solution set

$[a, b]$  and  $3\sin^{-1}x = \pi - \sin^{-1}(3x - 4x^3) \dots (ii)$

has solution set  $[c, d]$

We know that,

$$3\sin^{-1}x = \begin{cases} \sin^{-1}(3x - 4x^3) & \text{for } \frac{-1}{2} \leq x \leq \frac{1}{2} \\ -\pi - \sin^{-1}(3x - 4x^3) & \text{for } -1 \leq x \leq -\frac{1}{2} \\ \pi - \sin^{-1}(3x - 4x^3) & \text{for } \frac{1}{2} \leq x \leq 1 \end{cases}$$

$$\Rightarrow [a, b] = [-1, -1/2] \text{ and } [c, d] = [1/2, 1]$$

$$\Rightarrow |a| + |b| + |c| + |d| = 1 + 1/2 + 1/2 + 1 = 3$$

7.  $2\cos^{-1}x = \sin^{-1}(2x\sqrt{1-x^2}); x \in [a, b]$  (given)

Here  $2\cos^{-1}x \in [0, 2\pi]$ ; where as  $\sin^{-1}(2x\sqrt{1-x^2}) \in \left[-\frac{\pi}{2}, \frac{\pi}{2}\right]$

$\therefore$  For above inequality to be valid range of both sides must be same i.e.,  $\left[0, \frac{\pi}{2}\right]$

$$\Rightarrow 2\cos^{-1}x \in [0, \pi/2] \text{ and } \sin^{-1}(2x\sqrt{1-x^2}) \in \left[0, \frac{\pi}{2}\right]$$

$$\Rightarrow \cos^{-1}x \in [0, \pi/4] \text{ and } \sin^{-1}(2x\sqrt{1-x^2}) \in \left[0, \frac{\pi}{2}\right]$$

Further let  $\cos^{-1} = \theta$  i.e.,  $\cos\theta = x$   
 $\sin 2\theta = 2\sin\theta \cos\theta = 2\cos\theta \sqrt{1-\cos^2\theta}$

$$\therefore \theta \in \left[0, \frac{\pi}{4}\right]$$

$$\Rightarrow \sin 2\theta = 2x\sqrt{1-x^2}$$

$$\Rightarrow \sin^{-1}(\sin 2\theta) = \sin^{-1}(2x\sqrt{1-x^2})$$

$$\Rightarrow 2\theta = \sin^{-1}(2x\sqrt{1-x^2}) \quad [\because 2\theta \in [0, \pi/2]]$$

$$\Rightarrow 2\cos^{-1}x = \sin^{-1}(2x\sqrt{1-x^2})$$

Thus for  $x \in \left[\frac{1}{\sqrt{2}}, 1\right]$  given equality is valid

$$\Rightarrow a = \frac{1}{\sqrt{2}}, b = 1 \quad \therefore \frac{1+a^2b}{a^2} = \frac{1+\frac{1}{2}(1)}{\frac{1}{2}} = 3$$

8.  $[\tan^{-1}x]^2 - 2[\tan^{-1}x] + 1 \leq 0 \dots (i)$ , where  $[x]$  stands for greatest integer  $\leq x$

$$\Rightarrow ([\tan^{-1}x] - 1)^2 \leq 0 \Rightarrow [\tan^{-1}x] = 1$$

$$\Rightarrow 1 \leq \tan^{-1}x < 2$$

$$\Rightarrow \tan 1 \leq \tan(\tan^{-1}x) < \tan 2$$

( $\because \tan^{-1}x$  is an increasing function  $\forall x \in \mathbb{R}$ )

$$\Rightarrow \tan 1 \leq x < \tan 2 \quad (\because \tan(\tan^{-1}x) = x \forall x \in \mathbb{R})$$

$$\Rightarrow x \in [\tan 1, \tan 2) \Rightarrow k = 1$$

9.  $x^2 + ax + \sin^{-1}(x^2 - 4x + 5) + \cot^{-1}(x^2 - 4x + 5) = 0 \dots (i)$

For (i) to be valid  $x^2 - 4x + 5 \in [-1, 1]$

$$\Rightarrow -1 \leq x^2 - 4x + 5 \leq 1$$

$$\Rightarrow x^2 - 4x + 6 \geq 0 \text{ and } x^2 - 4x + 4 \leq 0$$

But  $x^2 - 4x + 6 > 0$  as Disc.  $< 0$  and  $x^2 - 4x + 4 \leq 0$

$$\Rightarrow (x^2 - 2)^2 \leq 0 \Rightarrow x = 2$$

$$\therefore 4a + 2a + \sin^{-1}(1) + \cot^{-1}(1) = 0$$

$$\Rightarrow 4 + 2a + \pi/2 + \pi/4 = 0$$

$$\Rightarrow 2a = -\frac{3\pi}{4} - 4$$

$$\Rightarrow a = -\left(\frac{3\pi+16}{8}\right) = -\left(\frac{3\pi+\lambda}{\mu}\right) \text{ (given)}$$

$$\Rightarrow \lambda = 16; \mu = 8 \Rightarrow \lambda - \mu = 16 - 8 = 8$$

10.  $m =$  number of positive integer solution of equation  $\tan^{-1}x + \cot^{-1}y = \tan^{-1}3 \dots (i)$

and  $(1 + ax)^n = 1 + 8x + 24x^2 + \dots (ii)$



4.138 > Trigonometry

Now,  $x, y \in \mathbb{Z}$

$$\Rightarrow \cot^{-1}y = \tan^{-1}(1/y) \text{ and } x \cdot \frac{1}{y} = \frac{x}{y} > -1$$

$$\therefore \text{From (i), } \tan^{-1}x = \tan^{-1}3 - \tan^{-1}(1/y)$$

$$= \tan^{-1}\left(\frac{3 - \frac{1}{y}}{1 + 3\left(\frac{1}{y}\right)}\right) = \tan^{-1}\left(\frac{3y-1}{y+3}\right)$$

$$\Rightarrow x = \frac{3y-1}{y+3} = \frac{3(y+3)-10}{y+3} = 3 - \frac{10}{y+3}$$

$$\therefore \text{For } y, x \in \mathbb{Z}; y+3 \in \{-10, -5, -1, 1, 5, 10\} \text{ i.e., } y \in \{-13, -8, -4, -2, 2, 7\}$$

$$\text{But } y \in \mathbb{Z}^+ \Rightarrow y \in \{2, 7\}$$

$$\Rightarrow x \in \{1, 2\}$$

$$\therefore (x, y) \in \{(1, 2), (2, 7)\} \text{ are two positive integer solution of (i)}$$

$$m = 2, \text{ also } (1 + ax)^n 1 + 8x + 24x^2 + \dots$$

$$1 + nax + \frac{n(n-1)a^2x^2}{2!} + \dots = 1 + 8x + 24x^2 + \dots$$

$$na = 8 \text{ and } \frac{n(n-1)a^2}{2} = 24$$

$$\Rightarrow n = 4 \text{ a} = 2$$

$$\text{Thus } (2m - a) = 2(2) - 2 = 2$$

11.  $\cos(2\sin^{-1}(\cot(\tan^{-1}(\sec(6\operatorname{cosec}^{-1}x)))))) = -1$

$$\sin^{-1}(\cot(\tan^{-1}(\sec(6\operatorname{cosec}^{-1}x)))) = \pm \frac{\pi}{2}$$

$$\cot(\tan^{-1}(\sec(6\operatorname{cosec}^{-1}x))) = \pm 1$$

$$\tan^{-1}(\sec(6\operatorname{cosec}^{-1}x)) = \pm \frac{\pi}{4}$$

$$\sec(6\operatorname{cosec}^{-1}x) = \pm 1$$

$$6\operatorname{cosec}^{-1}x = \pm 3\pi, \pm 2\pi, \pm \pi$$

$$\operatorname{cosec}^{-1}x = \pm \frac{\pi}{2}, \pm \frac{\pi}{3}, \pm \frac{\pi}{6}$$

$$\Rightarrow x = 1, \frac{2}{\sqrt{3}}, 2$$

( $\because x > 0$ )

12.  $\tan^{-1}n + \tan^{-1}(n+1) + \tan^{-1}(n+2) = \pi$

$$\tan^{-1}n + \pi + \tan^{-1}\frac{(n+1+n+2)}{(1-(n+1)(n+2))} = \pi$$

$$\tan^{-1}n + \pi - \tan^{-1}\frac{(2n+3)}{(n^2+3n+1)} = \pi$$

$$n = \frac{2n+3}{n^2+3n+1}$$

$$n^3 + 3n^2 - n - 3 = 0$$

$$n = 1 \text{ as } n \in \mathbb{N}$$

13.  $\sin(\cos^{-1}y) = \frac{-(x + \frac{1}{x})}{2}; x \neq 0$

only possibility is;

$$\sin(\cos^{-1}y) = \pm 1 \text{ \& hence } x = \pm 1$$

$$\text{if } x = 1 \Rightarrow \sin(\cos^{-1}y) = -1$$

$$\Rightarrow \text{Not Possible}$$

[ $\because 0 \leq \cos^{-1}y \leq \pi$ ]

$$\text{if } x = -1 \Rightarrow \sin(\cos^{-1}y) = 1$$

$$\Rightarrow y = 0; \text{ So } x = -1 \text{ \& } y = 0 \text{ is solution}$$

14.

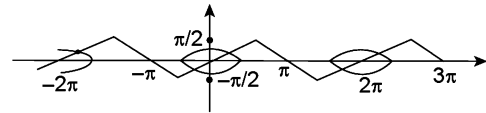

The graph of  $|y| = \cos x$  &  $y = \sin^{-1}(\sin x)$  intersects at 5 points in  $[-2\pi, 3\pi]$

15.

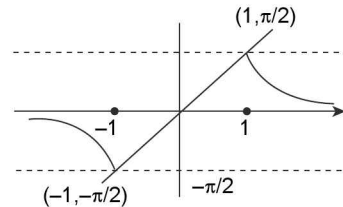

From graph it is clear that  $m \in \left(0, \frac{\pi}{2}\right] \therefore \lambda = 5$

16.  $\tan^{-1}\left[\frac{3\sin 2\alpha}{5+3\cos 2\alpha}\right] + \tan^{-1}\left[\frac{\tan \alpha}{4}\right]$   
 $= \tan^{-1}\left(\frac{6\tan \alpha}{8+2\tan^2 \alpha}\right) + \tan^{-1}\left(\frac{\tan \alpha}{4}\right) \left(\because \frac{3\tan^2 \alpha}{16+4\tan^2 \alpha} < 1\right)$   
 $= \tan^{-1}(\tan \alpha) = \alpha = \lambda\alpha/4 \Rightarrow \lambda = 4$