

ORIGAMI UNDER THE SEA

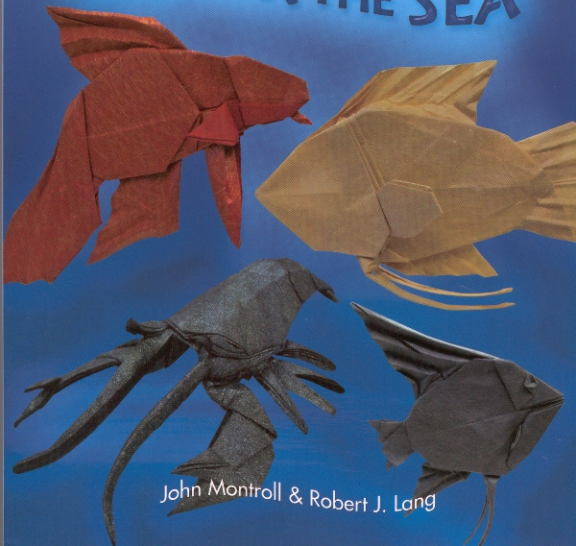

John Montroll & Robert J. Lang

Origami

Under the Sea

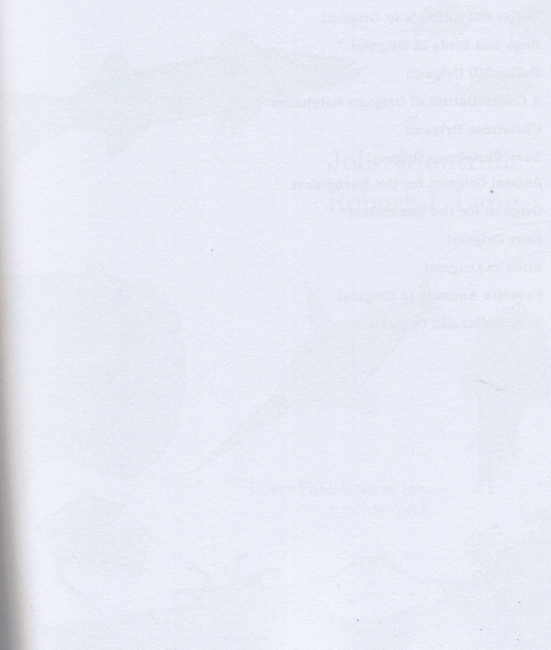

Other books by John Montroll:

- Dinosaur Origami**
- Origami Sculptures**
- Teach Yourself Origami**
- Bringing Origami to Life**
- Dollar Bill Animals in Origami**
- Bugs and Birds in Origami**
- Dollar Bill Origami**
- A Constellation of Origami Polyhedra**
- Christmas Origami**
- Easy Christmas Origami**
- Animal Origami for the Enthusiast**
- Origami for the Enthusiast**
- Easy Origami**
- Birds in Origami**
- Favorite Animals in Origami**
- Easy Dollar Bill Origami**

Origami

Under the Sea

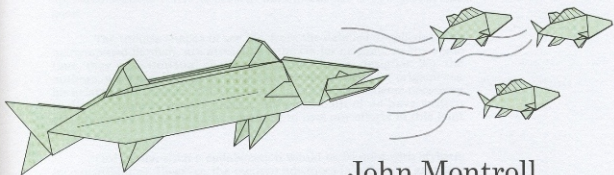

John Montroll
Robert J. Lang

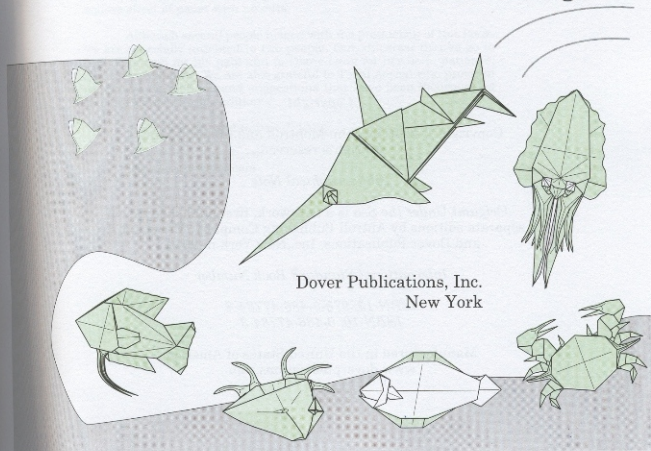

Dover Publications, Inc.
New York

To Deborah and Joey

To Peter and Diane

Copyright

Copyright © 2010 by John Montroll and Robert J.Lang
All rights reserved.

Bibliographical Note

Origami Under the Sea is a new work, first published in separate editions by Antroll Publishing Company, Maryland, and Dover Publications, Inc., New York in 2010.

International Standard Book Number

ISBN-13: 978-0-486-47784-8

ISBN-10: 0-486-47784-3

Manufactured in the United States of America
www.doverpublications.com

Introduction

The sea is nearly a world unto itself; it is vast, ecologically rich, complex, and yet, we are acquainted with only the tiniest fraction of its varied life. Its denizens include both the largest and smallest of creatures, creatures timid and aggressive, creatures mundane and outlandish. The sea was the cradle of life some four billion years ago; nearly every major phylum of life evolved in its waters, and many fanciful forms appeared over the eons. Its present inhabitants are the subject of this book.

The unique shapes of sea life, from the detailed angelfish to the many-spined lionfish, are attractive subjects for origami. At the same time, they pose unusual challenges to the origami designer. We, the authors, were independently moved to develop designs for origami sea life in large part because of the challenge in providing the detail necessary to do the subjects proper justice. Although both of us have written origami books independently, we chose to pool our efforts in this joint effort.

Ordinarily, such a collaboration would be fraught with stylistic incompatibilities. However, the modern advances in computer graphics have enabled us to create consistent, easy-to-follow directions for each model. The directions use the Randlett-Yoshizawa notation with our own enhancements for more advanced procedures, and the style of folding is that of the modern purist: every model is folded from one square sheet of paper with no cuts.

Although several people helped with the production of this book, we are especially indebted to two people. Our sincerest thanks go to Andy Montroll for his help and to Diane Lang for her help, patience, and understanding. We are also grateful to Toshi Aoyagi who provided numerous corrections and suggestions that have been incorporated into the History in this edition.

John Montroll and Robert J. Lang

www.johnmontroll.com

www.langorigami.com

Contents

- 8 A History of Origami Sea Life
- 12 Symbols
- 13 Frog Metamorphosis
- 25 Sea Mammals
- 34 Mollusks
- 46 Fishes
- 100 Crustaceans
- 118 Basic Folds
- 120 Credits

- * Simple
- ** Intermediate
- *** Complex
- **** Very Complex



Tadpole
*
page 14



Tadpole with Hind Legs
*
page 16

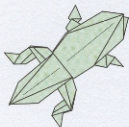

Froglet
**
page 18

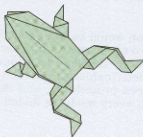

Frog
**
page 22

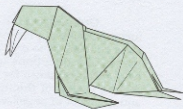

Walrus
**
page 26

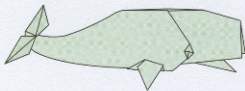

Sperm Whale
**
page 28

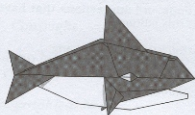

Killer Whale
**
page 31



Hawk-Wing Conch
**
page 35

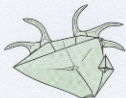

Spider Conch

page 37

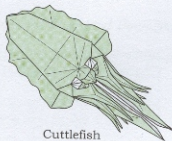

Cuttlefish

page 40

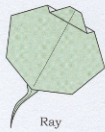

Ray
*
page 47

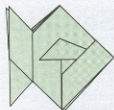

Tokinobu's Goldfish
**
page 48

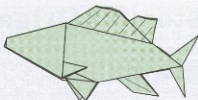

Perch
**
page 50

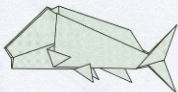

Carp
**
page 53

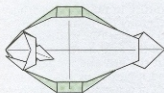

Brill
**
page 57

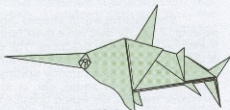

Swordfish
**
page 61

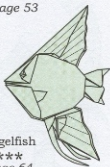

Angelfish

page 64



Siamese Fighting Fish

page 68

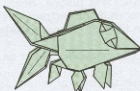

Goldfish

page 72

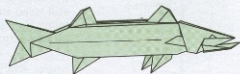

Barracuda

page 77



Angler Fish

page 82

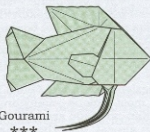

Gourami

page 86

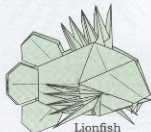

Lionfish

page 92



Bay Barnacle
*
page 101

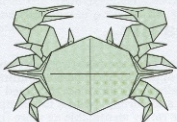

Blue Crab

page 102

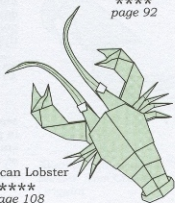

American Lobster

page 108

A History of Origami Sea Life

Origami, the art of paper folding, was developed in Japan over a period of some fifteen centuries. Japan is a land with limited natural resources, and its people have always adapted what materials were at hand for their needs. Thus, paper, which could be made from the abundant trees, was used widely as a structural and decorative medium. In the national religion, Shinto, both abstract and representational figures are used as decorations and for ceremonial purposes. Quite early on, such figures were made from paper, and such figures were the original origami designs.

The natural world shaped Japanese culture in many ways. Those aspects of nature that were most familiar to everyday life figured the most heavily in ceremonial practices. The sea played a major role in the culture of Japan, an island nation; it provided much of the food in the daily diet, and a wide body of ceremony sprang up about the sea and its denizens, such as the ika, or squid, ebi, or shrimp, and maguro, or tuna. It was inevitable that sea life would become the subject of origami, and that those creatures that graced the Japanese table would also grace the world of origami.

As early as the twelfth century, sea life and origami were combined in the abstract *noshi-awabe*, a pleated paper ornament in which a strip of dried abalone (*awabe*) was placed. *Noshi* were attached to gifts to signify the hope of the giver that the recipient would enjoy good fortune. They are still used in Japan for this purpose, although the twentieth century has taken its toll on this tradition. One is now as likely to find the *noshi* design merely printed on the wrapping paper as separately folded and attached.

Representational origami sea life is also hundreds of years old. One of the earliest existing sets of origami instructions is contained in the classic work *Kan-no-mado* ("Window on Mid-Winter"), which includes directions for folding 48 popular traditional origami designs. Among various animals and human figures, the *Kan-no-mado* includes several sea creatures—a shrimp, a crab, an octopus, and a lobster. All four designs, interestingly enough, make heavy use of cuts in the paper.

An aside about cuts is in order here. Now that origami is a worldwide phenomenon with tens of thousands of devotees, it is widely assumed that the traditional rules for origami are "one square, no cuts." In fact, these strictures are of relatively recent origin. While many of the traditional origami designs are in fact folded from a single uncut square—the crane being the most famous—many are not. In fact, none of the sea creatures from the *Kan-no-mado* are without cuts. This is because origami sea life, more than almost any other genre, places unusual demands upon the designer, due to the large numbers of limbs, irregular shapes, and mismatched points. Only in the past few years have origami sea creatures appeared that were not highly stylized, indistinct, from multiple sheets, or cut.

Early sea life

It was not until the mid-twentieth century that one-piece, no-cut sea life began to appear in the origami literature; yet, because of the difficulty in producing realistic sea life, most remained highly stylized. Arthropods—crabs, lobsters, and shrimp—with a full complement of legs were unheard of, and fish were rarely identifiable as more than simply "fish." Yet, slowly, a body of origami sea life designs evolved.

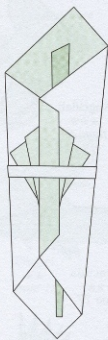

An example of the noshi, a folded paper ornament signifying wishes for good luck. Traditional noshi enclosed a strip of dried abalone.

Many of them were the product of the father of twentieth-century origami, the Japanese master Akira Yoshizawa. Yoshizawa began developing new designs in the 1930s and 1940s in relative obscurity. However, as his designs and photographs of finished works began to appear in Japanese books and magazines, his stature grew and his reputation spread to the Western world. His masterwork, *Origami Dokuho*, was published in 1957, and, among more traditional sea creatures (a simple fish and frog), it contained a lobster, albeit legless, from an equilateral triangle.

Several other Japanese folders were active throughout the 1950s and 1960s as well, and added to the ranks of origami sea life. Typical of the period were Isao Honda's *The World of Origami*, published in 1965, which included a legless shrimp with cut antennae, a seal with cut rear flippers, a penguin, several generic fish, a goldfish with cut fins, the traditional frog, and a crab with cut legs; and Kunihiko Kasahara's *Creative Origami*, published in 1967, which contained a legless crawfish (from a right triangle), a goldfish, a shark, a blowfish (with cuts), a seahorse, a whale, and an octopus, crab, and squid, each with four legs apiece.

Meanwhile, in the West, origami was growing steadily in popularity, and Western folders were beginning to see their designs in print. Robert Harbin's *Secrets of Origami* (1963) contained traditional designs such as a frog, a cut octopus, and original Western creations including an angelfish, a whale, a seal, and a sea horse. James Minoru Sakoda's *Modern Origami* (1969) further expanded the Western repertoire with a seal, an angelfish, and a two-legged lobster.

Recent developments

Kunihiko Kasahara's *Viva Origami* (1983) was a breakthrough publication for Japanese origami, as it contained the first Japanese publication of highly complex models from squares—all designs of a young Japanese physicist, Jun Maekawa. Many of the designs were multipointed, including ten-fingered human figures and a frog whose feet had three and four toes each; however, the only crustacean, a crab, was disappointingly given only two legs. However, in his next book, *Top Origami* (1985), Kasahara included work from many different folders, including a host of shells of unprecedented realism from Kawasaki Toshikazu. Toshikazu was the first folder to develop a successful general method for achieving a spiral shell, which he accomplished by weaving four points around each other. *Top Origami* contained several shells from Toshikazu: an ivory shell, a turban shell, and a murex; the last, however, was heavily cut to produce its points.

Meanwhile, Yoshizawa had produced his self-proclaimed second masterwork, *Origami Dokuho II* (1984), which included instructions for the first time for his one-piece uncut crab, as well as a starfish from a Bird Base, a three-armed squid, a flying fish, a dolphin, a seahorse, and two other fish. Although the instructions for the crab were not published until 1984, photographs had been published in Japan many years earlier, making it possibly one of the earliest of the "realistic" designs. *Dokuho II* also contained photographs (no instructions) of a sea turtle, scallops, a two-legged hermit crab, and an octopus.

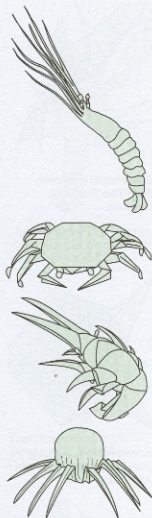

Four sea creatures from the Kan-no-mado, ca. 1797. (Top to bottom): shrimp, crab, lobster, octopus.

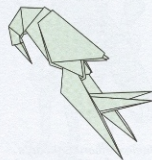

Kunihiko Kasahara's lobster, from Creative Origami.

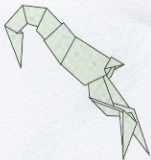

Isao Honda's lobster, from *The World of Origami*.

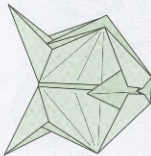

James Minoru Sakoda's angelfish, from *Modern Origami*.

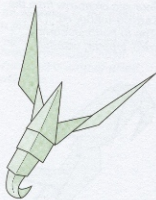

James Minoru Sakoda's lobster, from *Modern Origami*.

In the West, several books containing complex models had appeared by this time, but the first to include a substantial aquarian offering was John Montroll's *Origami for the Enthusiast* (1979), which contained a fish, goldfish, seahorse, whale, and sunfish. It was the first publication of fish with the appropriate number and locations of fins. He followed it with *Animal Origami for the Enthusiast* (1985), which (like *Top Origami*) contained a frog with the appropriate number of toes, as well as an angelfish, a crab, a seal, a walrus, and a lobster. The last was a major feat of origami design, achieving for the first time all eight legs, claws, antennae, and even eyestalks.

Most recently, Peter Engel's *Folding the Universe* (1989) has taken the subject matter of sea life to new heights; it contains an angelfish, a butterflyfish, a discusfish, a dollar bill crab, a crab from a square, and, for the first time, octopus and squid of unusual realism, including eyes, funnels, and the appropriate number of legs. *Folding the Universe* was an unusual origami book in that a significant fraction of the book was given over to material other than folding instructions. In it, Engel examined the very roots of origami, the process of folding design and how it related to creativity, engineering, and geometry. And in doing so, he touched on why the design of origami sea life is so difficult.

Design

Of all the phyla of the animal kingdom, sea creatures pose some of the most difficult challenges to the origami designer. In large part, this is due to the natural environment in which they have evolved. Unlike their land-based brethren, sea creatures are continuously supported by water on all sides. This has resulted in creatures with large numbers of abnormally long legs at one extreme, and creatures without any appendages at all at the other. Neither extreme lends itself easily to origami design.

Ultimately, systematic origami design is based on symmetry. The square has certain symmetries; the subject has other symmetries. Most of the effort of the designer consists of altering the symmetry of the square to approximate that of the subject. The process of design is simple if the symmetry of the square already matches that of the subject—for example, if the subject has four limbs that may be made from the square's four corners. If the subject has many more limbs than four, additional points must be developed from the edge of the square and possibly even from the middle, which requires more complex and difficult folding.

Fish offer a unique problem to the origami designer. The early part of the design of a subject consists of developing a geometric shape, called a "base," that has the same number, location, and size of points as the subject. Points are usually derived in pairs. Yet, the dorsal, ventral, anal, and caudal fins of a fish are singular. The designer is faced with the problem of either constructing a base with unmatched points or wastefully "throwing away" one of a pair of points by hiding it or tucking it away inside the model.

Mollusks, those creatures with shells, pose a different problem from fish. Most shells are symmetric, but it is the wrong kind of symmetry. Seashells often have a chiral symmetry (that is, they come in right- and left-handed versions), typified by a spiral structure. Such a shape does not have reflection symmetry—that is, the shell is not the same as its mirror image—but most origami bases do. Thus, design of a shell calls for wholly new design techniques to achieve the spiral. Things are further complicated when you add in extra spines, as many shells, particularly those of the family Muricidae, possess.

And then there is simply the problem of numbers. Supported by water, the limbs of sea creatures have evolved to enormous lengths compared to their diameters. Some creatures appear to be nothing more than collections of long, spindly legs, antennae, and eyestalks. To the origami designer, long legs are an anathema; they consume large amounts of paper and are extremely difficult to make with an aspect ratio (the ratio of length to width) of more than 5:1. Many sea creatures have all their limbs with aspect ratios of 100:1 or more. Add to that the fact that arthropods—crabs, lobsters, and shrimp—routinely have ten or more such appendages (echinoderms—sea urchins and sea stars—can have hundreds), and it becomes clear why the origami designers of old used cuts with such abandon.

In one way, however, arthropods are suited to origami. An inevitable by-product of folding shapes with many appendages is the presence of sharp lines at the joints between the appendages and the main body. In fact, origami models must necessarily have a sharp line or edge whenever a point changes size or direction, and the eye is inevitably drawn to these lines. This interaction between the observer and the paper affects the origami design in two ways. First, if several such lines are close to one another, the eye is drawn toward the group, which detracts attention from the rest of the model and gives the impression of clutter. Second, the eye tends to interpret the line as a joint in the subject, whether there is supposed to be one or not. Fortunately, underwater arthropods (and their terrestrial relatives as well) have joints wherever an appendage changes size or direction, just like an origami appendage. Thus, little effort is required to convert a point into a leg. With an arthropod, if the number and locations of legs can be achieved, the rest quickly follows.

The opposite extreme from the leggy, jointed arthropods are those creatures with too few legs; those of the amorphous body. These include sea slugs, sea cucumbers, coral, and sponges. Origami, even at its most realistic, is successful only as a cartoon, an abstraction. It must somehow include those features of the subject that are the most distinctive. The human eye is most readily drawn to outlines and geometric features—number and location of appendages, for example—and so those features are what origami designers have concentrated on. However, the amorphous subjects, such as coral or sponges, are recognized not by their outlines but by their textures, and origami textures have not been well developed. Similarly, other subjects that are difficult to achieve with origami are creatures that are light and feathery, such as sea lilies, and creatures with many limbs but no natural joints to use to hide fold lines, such as starfish and octopi.

Over the past few years, the challenges inherent in the design of realistic origami sea creatures attracted both of the authors to the genre. Independently, we developed techniques to form legs, antennae, claws, fins, flukes, legs, and spines; then, learning of the other's developments, we decided to pool our efforts. The result is this book. In *Origami Sea Life*, we have developed creatures of the water of all types: fish, seashells, crabs, lobsters, whales, amphibians, echinoderms, and mollusks. While many of the designs are simple enough for the novice folder, many of them are among the most complex ever published, and should prove challenging to even the most advanced folder.

One of the encouraging aspects of present-day origami is the speed at which the field is evolving. Ten years ago, many of the designs contained in this book would have been unthinkable. Ten years from now, who knows what might be possible?

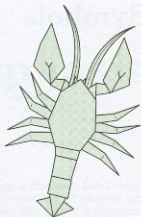

John Montroll's lobster, from Animal Origami for the Enthusiast.

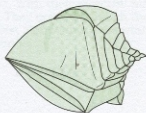

Toshikazu Kawasaki's ivory snail, from Top Origami.



Peter Engel's octopus, from Folding the Universe.

Symbols

Lines



Valley fold, fold in front.

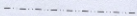

Mountain fold, fold behind.



Crease line.

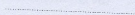

X-ray or guide line.

Arrows

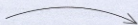

Fold in this direction.



Fold behind.

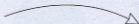

Unfold.



Fold and unfold.



Turn over.



Sink or three dimensional folding.



Place your finger between these layers.

Frog Metamorphosis

The metamorphosis of a tadpole into a frog is a fascinating sequence of events which can be witnessed at almost any pond in the world. Frogs lay many jelly-like, nearly transparent eggs in the water. Tadpoles hatch from the eggs and breathe through gills. The young tadpole initially has no legs at all. Soon, however, the hind legs begin to form. Then the front legs appear. When the gills have changed to lungs the tadpole has become a young frog ready to go on land. Finally the tail disappears.

Adult frogs are tailless amphibians. With their powerful hind legs, they are very good at leaping. They breathe through their mouths and also through their moist skin. During the winter they hibernate at the bottom of ponds.



Tadpole

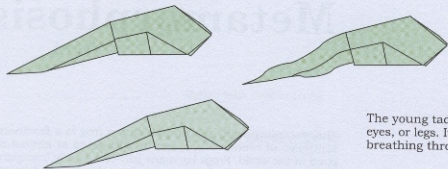

The young tadpole has no mouth, eyes, or legs. It swims in the water, breathing through gills.

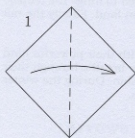

Fold in half.

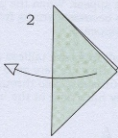

Unfold.

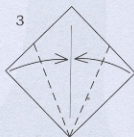

Kite-fold.

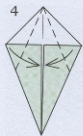

Kite-fold.

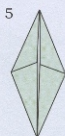

Turn over.

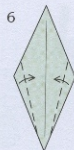

Turn over.

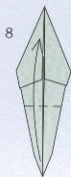

Fold almost all the way down.

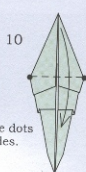

Use the dots as guides.

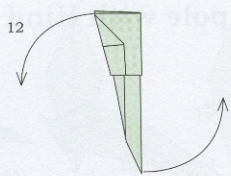
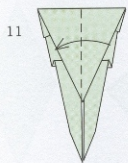

Rotate the model.

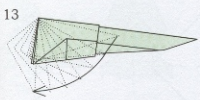

Slide out the inner point.
The dotted lines show the folds in motion.

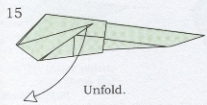
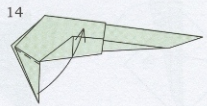

Unfold.

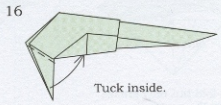

Tuck inside.

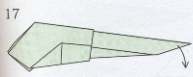

Slide the tail down.

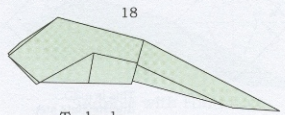

Tadpole

Tadpole with Hind Legs

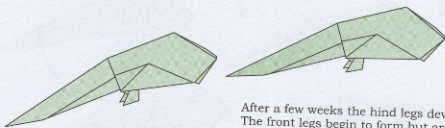

After a few weeks the hind legs develop. The front legs begin to form but are hidden. The tadpole now eats algae.

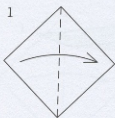

1 Fold in half.

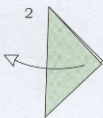

2 Unfold.

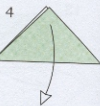
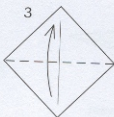

4 Unfold.

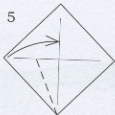

5 Kite-fold but only crease below the center line.

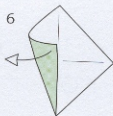

6 Unfold.

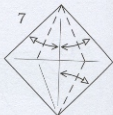

7 Fold and unfold three more times.

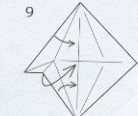
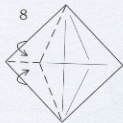

8 This is a 3D intermediate step showing the formation of the rabbit ear.

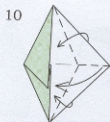

9 A rabbit ear has been completed on the left side. Fold another rabbit ear on the right.

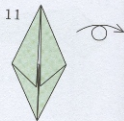

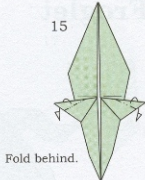
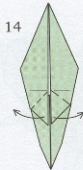
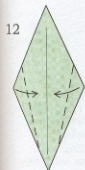

Fold behind.



Fold almost all the way down.

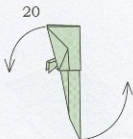
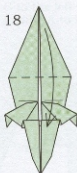

Rotate the model.

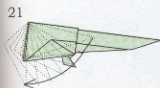

Slide out the inner point. The dotted lines show the folds in motion.

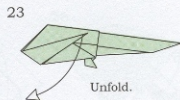
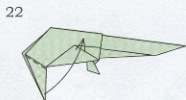

Unfold.

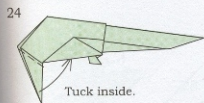

Tuck inside.



Slide the tail down.

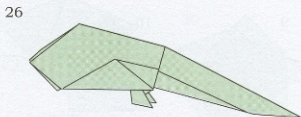

Tadpole with Hind Legs

Froglet

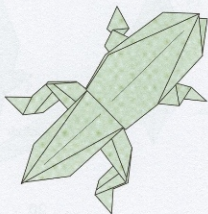

After a few months, the tadpole changes much more. The front legs appear. The gills disappear while the mouth becomes wider. The eyes become larger. It stops eating, digesting the materials in its tail. With a shrinking tail, the young frog is now ready to leave the water.

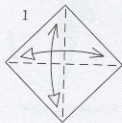

1
Fold and unfold.

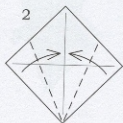

2
Kite-fold.

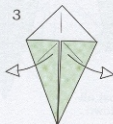

3
Unfold.

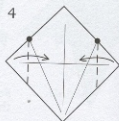

4
Use the dots as guides.

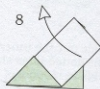
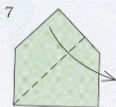
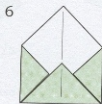
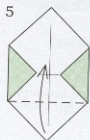

8
Unfold.

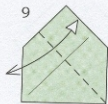

9
Fold and unfold.

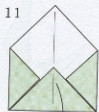
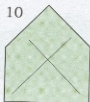

11
Unfold.

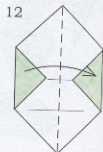

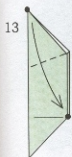

13



14

Unfold.

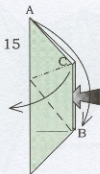

15

Squash-fold. Fold C to the left while folding A to B.

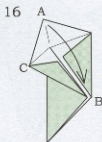

16

This is a 3D intermediate step.

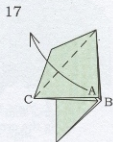

17



18



19



20

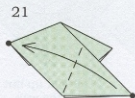

21



22

Unfold.

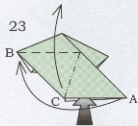

23

Squash-fold. Fold C up while folding A to B.



24



25

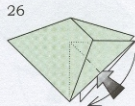

26

Reverse-fold.

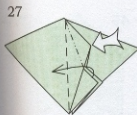

27

Spread-squash-fold.

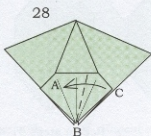

28

Fold line B-C to line A-B.

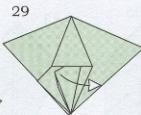

29

Unfold.

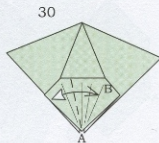

30

Fold and unfold to line A-B.

31

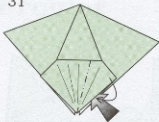

Reverse-fold
along the crease.

32

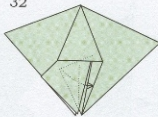

Reverse-fold.

33

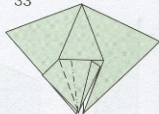

Repeat steps
31-32 on the left.

34

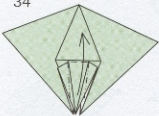

Petal-fold up but
not all the way.

35

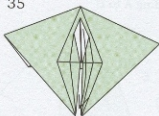

36

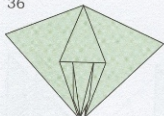

37

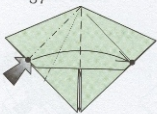

Squash-fold so
the dots meet.

38

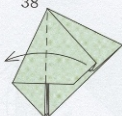

39

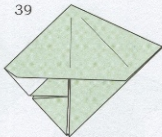

Repeat steps 37-38
on the right.

40

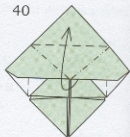

Petal-fold.

41

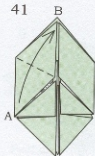

Fold A to B.

42



A 3D intermediate
step.

43



44



Repeat steps 41-43
on the right.

45

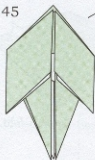

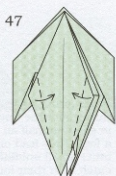
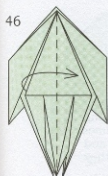

Repeat steps
46-48
on the right.

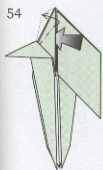
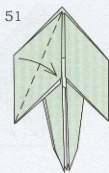
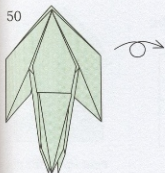

Slide the paper out
to the dotted lines.

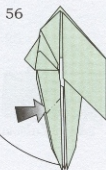
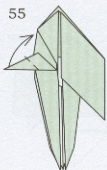

Reverse-fold.

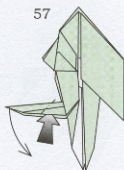

Reverse-fold.



Form the feet with
squash folds.

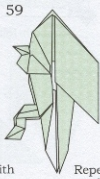

Repeat steps 51-58
on the right.

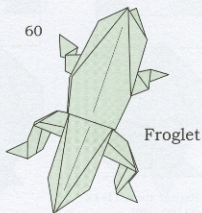

Froglet

Frog

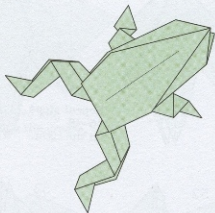

Frogs (order *Anura*) are found throughout the world. They range in size from half an inch to almost a foot. They feed on insects and other small animals which they catch with their long sticky tongues.

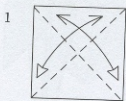

1 Fold and unfold.

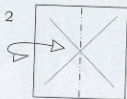

2 Fold behind and unfold.

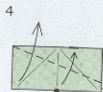
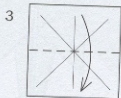

4 Fold up so the dot meets the edge.

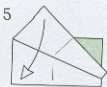

5 Unfold.



6 Fold and unfold.

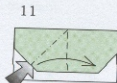
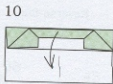
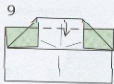
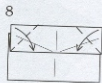

11 Squash-fold.

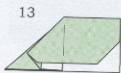
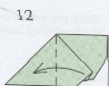

13 Repeat steps 11-12 on the right.



14 Petal-fold.



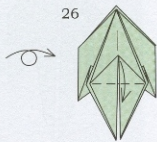
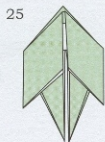
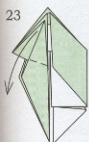
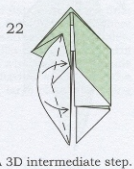
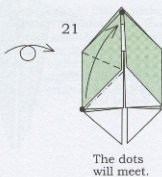
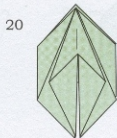
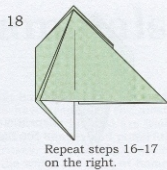
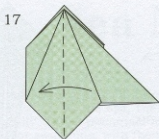
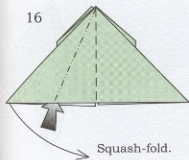

Repeat steps 21-23 on the right.

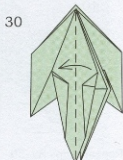
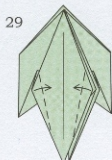
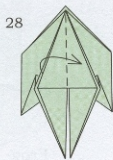
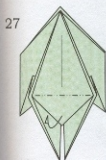

31



Repeat steps 28-30
on the right.

32



33



34

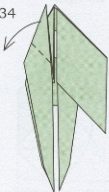

35

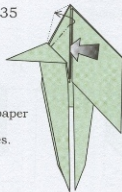

Slide the paper
out to the
dotted lines.

36

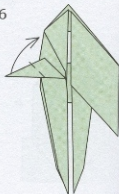

37

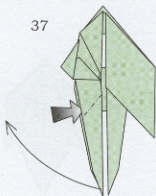

Reverse-fold.

38

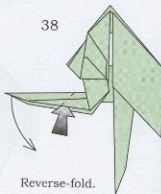

Reverse-fold.

39

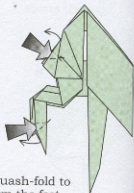

Squash-fold to
form the feet.

40

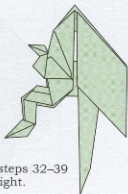

Repeat steps 32-39
on the right.

41

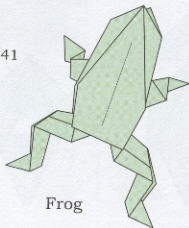

Frog

Sea Mammals

Among the many groups of animals that have returned from land existence to life in the sea, the whales have readapted the most successfully. These mammals feed on other sea life and are well adapted for swimming, with their streamlined shapes and powerful adaptations for swimming. Seals, walruses, and sea lions, while spending portions of their time out of the water are most at home under the surface, and whales, though they still breathe air, are entirely aquatic.

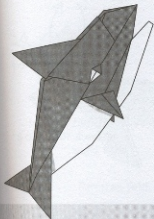

Whales may be most easily distinguished from fish by their tail fins; those of a whale are horizontal, while those of a fish are vertical. There are two groups of whales, the toothed whales, and the baleen whales. Toothed whales include dolphins, porpoises, killer whales, and sperm whales, and feed on squid and fish. The baleen whales, which include the blue whale, the largest of all living animals, feed on small crustacea called krill, which it strains through its baleen, large plates that hang from the upper jaw.

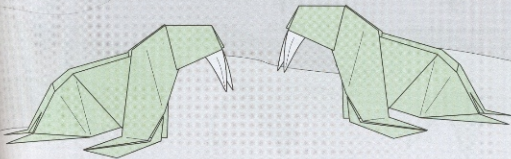
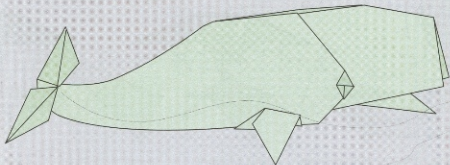

Walrus

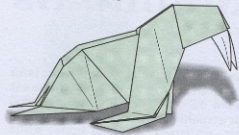

The Walrus (*Odobenus rosmarus*) is one of the most comical-looking animals in the world. With his oversize tusks and bushy moustache, the male walrus resembles an old sea captain. Although walruses seem very lethargic sprawled on northern beaches and ice floes, they are actually capable of great speed on land as well as in the water. They feed primarily on fish and shellfish and may grow up to 15 feet long.

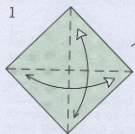

1 Crease the diagonals.
Turn the paper over.

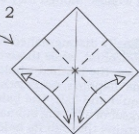

2 Fold and unfold.

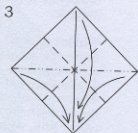

3 Make a Preliminary Fold.

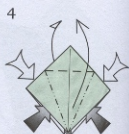

4 Petal-fold in front and back to make a Bird Base.

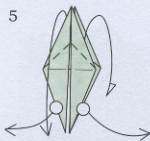

5 Hold each of the two bottom flaps and pull them out to the sides. Simultaneously, swing the top flap down.



6 Flatten it out.

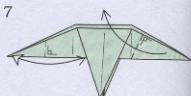

7 Fold and unfold on the left; fold the right point up.

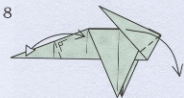

8 Fold and unfold the left point; fold the right point down.

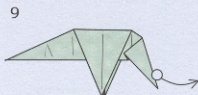

9 Unfold.

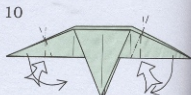

10 Crimp each side on existing creases.

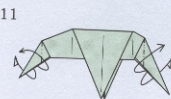

11 Pull out one layer from each side.

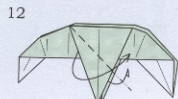

12 Fold the front and back points as far to the right as possible.

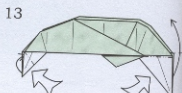

13 Reverse-fold.

14

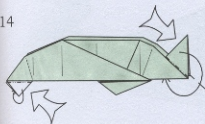

Reverse-fold.

15

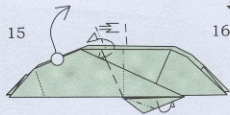

Crimp the body.

16

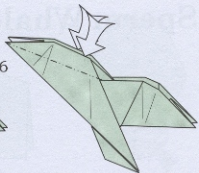

Closed-sink two layers.

17

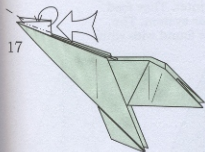

Reverse-fold.

18

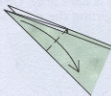
Fold one point
down as far as
possible.

19

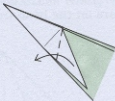
Fold it back to
lie along the
existing crease.

20

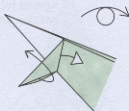
Wrap two layers
to the left. Turn
the paper over.

21

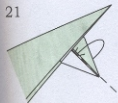
Tuck both layers
into the pocket. Turn the
paper over.

22

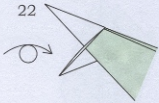
Repeat steps
19-21 on the
other side.

23

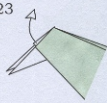
Pull out the
middle layer.

24

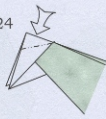
Reverse-fold
on an existing
crease.

25

Tuck both sides
into pockets.

26

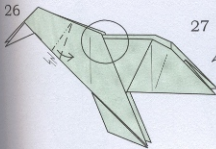
Mountain-fold the points
inside the back and crimp
the head down.

27

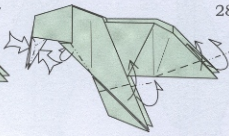
Pinch the tusks. Narrow
the neck with mountain folds. Fold
the flippers outwards.

28

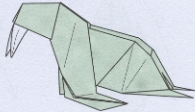

Walrus

Sperm Whale

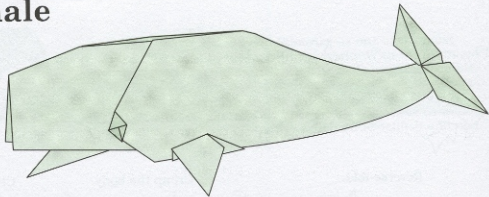

These 60-foot-long toothed whales have teeth only on their lower jaw. Traveling in herds of 20 to 50, they migrate towards the equator in winter. They feed mainly on giant squid which they can detect with their sonar system. The sperm whale (*Physeter macrocephalus*) is dark gray. Often it is found with white marks and scars on the head from fighting the giant squid.

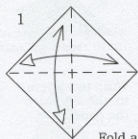

Fold and unfold.

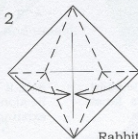

Rabbit ears.

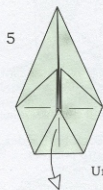

Unfold.

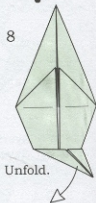

Unfold.

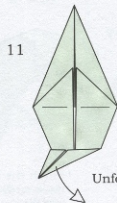
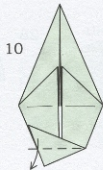

Unfold.

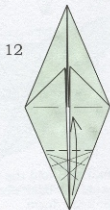

13

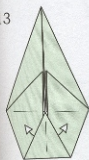

Pull out some paper.

14

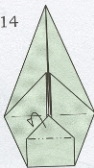

15

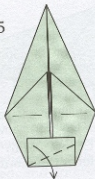

16

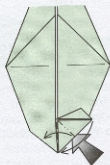

Squash-fold.

17

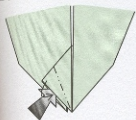
Enlarged view.
Reverse-fold.

18

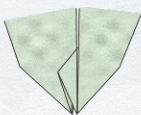

19

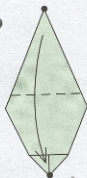

20

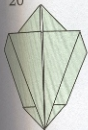

21

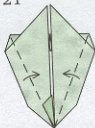
Tuck the edges behind
the darker paper.

22



23

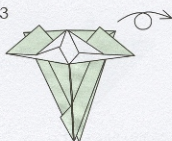

24

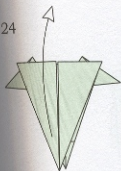

Unfold.

25

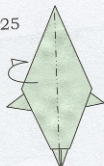

26

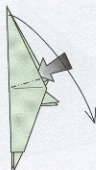

Reverse-fold.

27

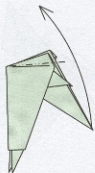
Reverse-fold up and
rotate the model.

28

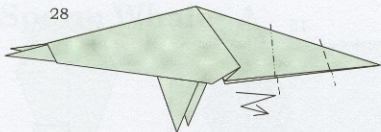

Crimp-fold to
form the mouth.

29

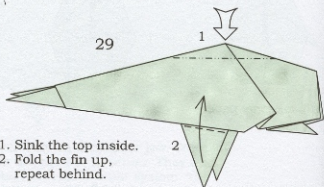

1. Sink the top inside.
2. Fold the fin up,
repeat behind.

30

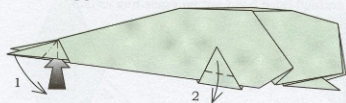

1. Squash-fold the tail.
2. Fold the fin down.
Repeat behind.

31

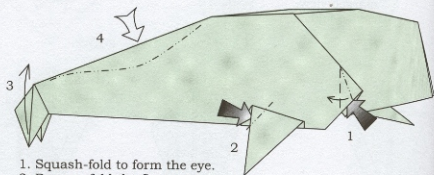

1. Squash-fold to form the eye.
2. Reverse-fold the fin.
3. Fold the tail up.
4. Shape the whale.
Repeat behind.

32

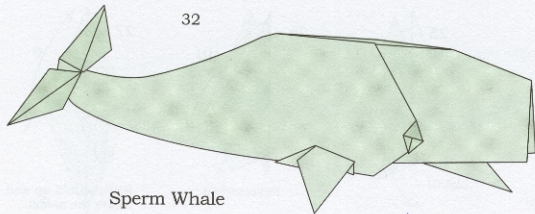

Sperm Whale

Killer Whale

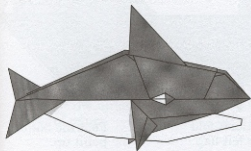

The killer whale (*Orcinus orca*) is not a whale at all, but rather a large dolphin, growing up to 30 feet long. Widely known as "the wolf of the seas," these whales roam in packs and have been known to attack the largest of whales, the blue whale; more commonly, however, they feed on fish, penguins, seals and squid, and have never been known to attack man. They are exceedingly intelligent creatures and are easily trained, and entertain at marine parks worldwide.

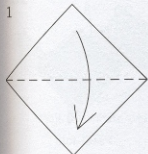

1
Fold the square in half along the diagonal.

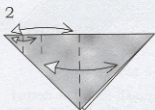

2
Fold and unfold three times.

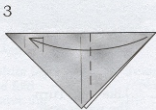

3
Fold the right corner over to touch the last crease you made.

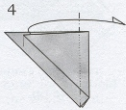

4
Fold the left corner behind on an existing crease.

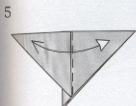

5
Fold and unfold.

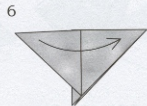

6
Fold the left corner over to the right.

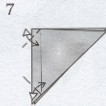

7
Fold and unfold.

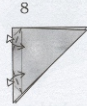

8
Fold and unfold.

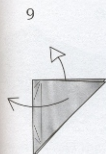

9
Unfold the paper completely.

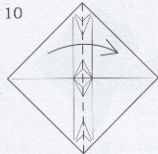

10
Fold the paper in half.

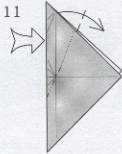

11
Reverse-fold, using existing creases. Don't make the crease sharp all the way.

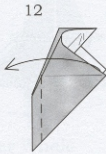

12
Fold one layer to the left on an existing crease.

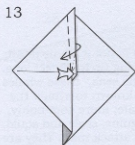

Fold the upper crease to the left, using existing creases to make the zig-zag.

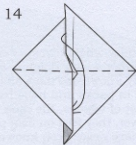

Fold the top half down and tuck the indicated flap into the lower pocket.

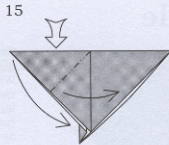

Squash-fold the left flap.

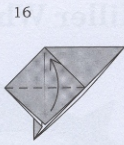

Fold the bottom point up.

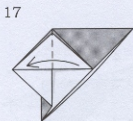

Close up.

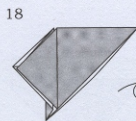

Like this. Turn the paper over.

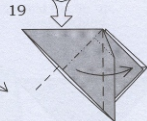

Squash-fold. The dotted line shows hidden layers.

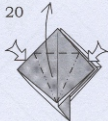

Petal-fold.

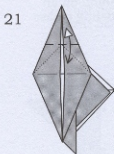

Fold and unfold.

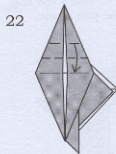

Fold the last crease down to touch the horizontal creases.

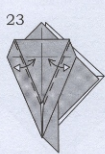

Fold and unfold.

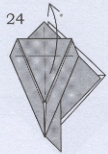

Unfold.

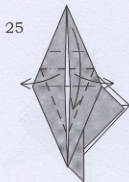

Open out the sides and fold the top down, all on existing creases.

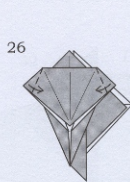

Fold the corners in so that the creases line up with the edges underneath.

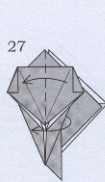

Close the model up and rotate 1/4 turn.

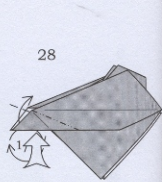

Reverse-fold both corners together as one on existing creases.

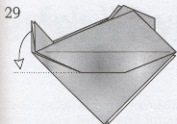

Pull out the inner layer of paper.

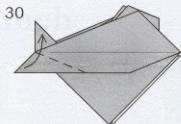

Fold the flap upward to line up with the other flap.

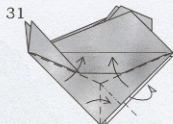

Fold a rabbit ear; repeat behind.

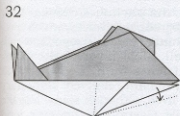

Pull the white point down slightly.

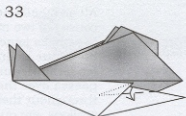

Valley-fold the white layer, forming a reverse fold where it goes under the short flap. Repeat behind.

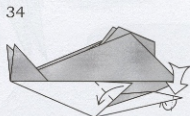

Fold the short flap down; repeat behind. Reverse-fold the tip of the white point.

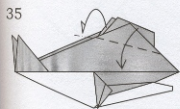

Fold the top flap down; repeat behind.

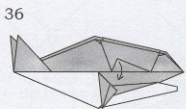

Unfold the corner. Repeat behind.

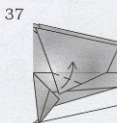

Fold the corner upward. Repeat behind.

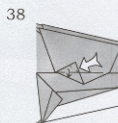

Squash-fold. Repeat behind.

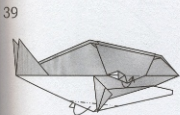

Mountain-fold the belly. Tuck the corner below the white spot under the lower layers, but leave the white spot showing. Repeat behind.

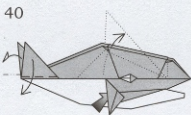

Fold the tail fins down. Open out the pectoral fins. Reverse-fold the dorsal fin up and out from the top of the body.

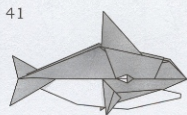

Killer Whale

Mollusks

The second largest phylum of the animal kingdom, mollusks are soft-bodied animals with no bones. Most of them are protected by a hard shell. Some of them, such as the squids and cuttlefish, grow their shell inside of them. And some, such as the octopus, have no shell at all.

All seashells belong to the phylum *Mollusca*. They consist of two major subgroups—bivalves, which have two shells joined by a hinge, and gastropods, which have but a single shell. Most bivalves are filter-feeders, straining nutrients from the water that passes over them, and remain relatively stationary throughout their adult lives, although some, like the scallops, are quite mobile. Gastropods, however, tend to be more active, and some, like the whelks, are voracious predators. Seashells are among the most satisfying of sea life to collect. The shells are often decorated with colorful patterns and spines, which retain their beauty long after their original inhabitants are gone.

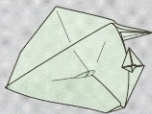
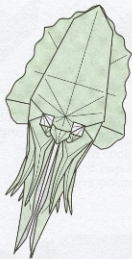

Hawk-Wing Conch

True conchs, family *Strombidae*, have large, heavy shells and inhabit tropical waters worldwide. Conchs are very mobile carnivores that move by pushing themselves along on a large, muscular foot. Their shells are large and robust, with a highly sculptured lip. This shell, the Hawk-Wing Conch (*Strombus raninus*), is further distinguished by a prominent tubular projection at the top of the mantle. It is found from Florida to the West Indies and Brazil.

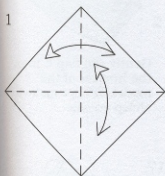
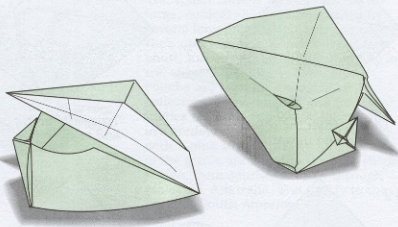

1
Crease the diagonals.

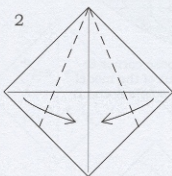

2
Fold the edges in to the center.

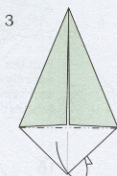

3
Fold the bottom corner up behind.

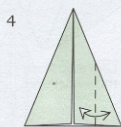

4
Fold the right corner in to the middle and back out again.

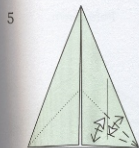

5
Crease the right corner into thirds. The upper crease lies on top of the hidden edge.

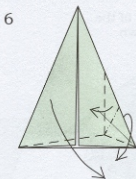

6
Fold a rabbit ear.

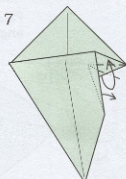

7
Swivel-fold.

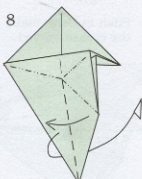

8
Pinch the flap in half and swing it over to the right. The model becomes three-dimensional.

9

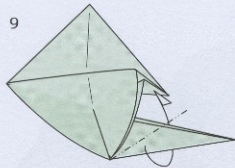

Loosely twist the point behind and upwards.

10

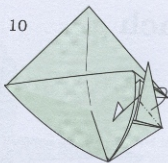

Twist it behind and to the left.

11

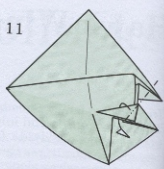

Continue until you run out of point.

12

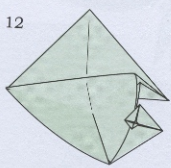

Like this. Turn the model over.

13

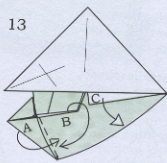

Pull the loose corner C entirely out of the model and bring points A and B together.

14

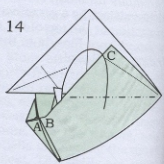

Gently roll flap C into the interior of the model. Do not make a sharp crease.

15

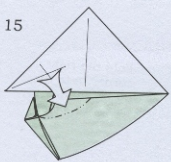

Push in here; make the crease curved.

16

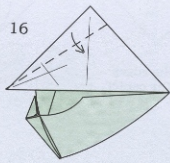

Fold 1/4 of the angle down.

17

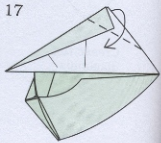

Fold down.

18

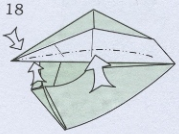

Pinch the point and shape the underside of the shell. Turn the model over.

19

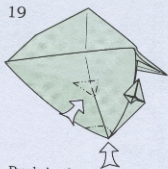

Push in these corners.

20

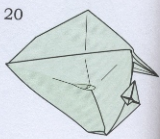

Hawk-Wing Conch

Spider Conch

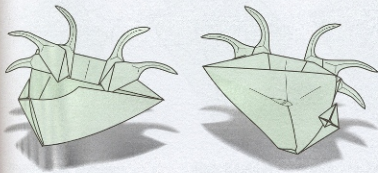

The spider conchs (genus *Lambis*) are large, conical shells distinguished by several long projections along the edge of their aperture lips, which may be long, short, knobby, or smooth, depending on the species. For this reason, spider conchs are popular among shell collectors. They range in size from four inches to about one foot in length and are predominantly tan on the outside with a pink inner surface. All members of the genus are found in the Indo-Pacific region, from southern Africa through Malaysia, Australia, and nearly to the coast of South America.

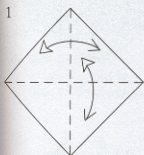

1
Crease the diagonals.

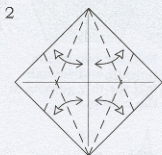

2
Bring the sides to the center line and unfold.

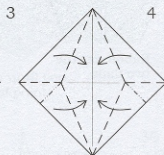

3
Fold a Fish Base.

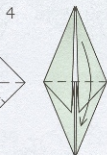

4
Fold the Fish Base in half.



5
Fold one flap up so that the right edges are parallel.



6
Unfold.



7
Fold the flap up so that the left edges are parallel.

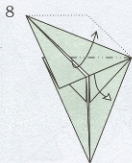

8
Pull out the trapped layers of paper.

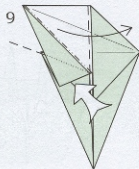

9
Squash-fold.

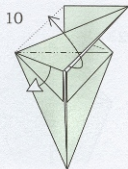

10
Pull out the loose paper.

11

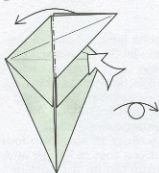

Reverse-fold. Turn the paper over.

12

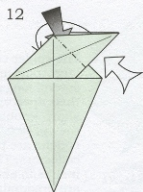

Reverse-fold the corner.

13

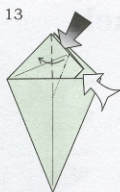

Squash-fold the corner.

14

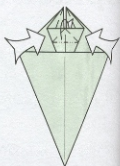

Inside petal fold.

15

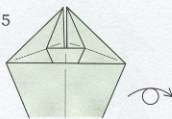

Like this. Turn the paper over.

16

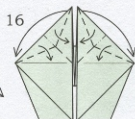

Rabbit-ear the two flaps.

17

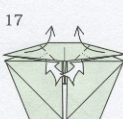

Fold the two points upward and squash-fold the tiny gussets at the bottom.

18

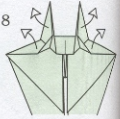

Unfold to step 16.

19

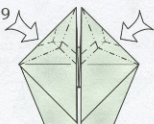

Sink the edges symmetrically.

20



Enlarged view, showing the creases in the interior.

21

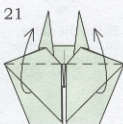

Fold two points up.

22

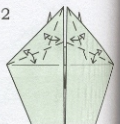

Crease.

23

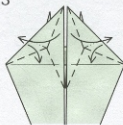

Rabbit-ear both points.

24

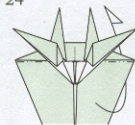

Fold the long point up to the rear.

25



Like this. Turn the paper over.

26

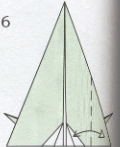

Fold the right corner in to the middle and unfold.

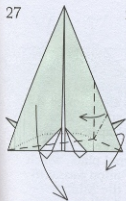

Rabbit-ear the flap on existing creases.

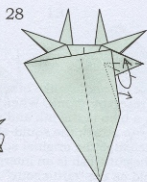

Swivel fold.

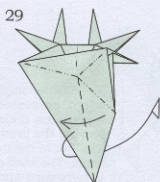

Pinch the bottom of the point in half and swing it up to the right. The model becomes three-dimensional.

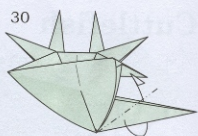

Mountain-fold the flap behind. This locks the folds from step 29 into place.

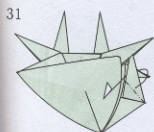

Mountain-fold the point behind again.

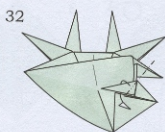

Continue until you run out of point.

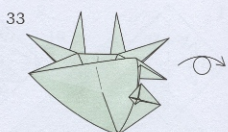

Like this. Turn the paper over.

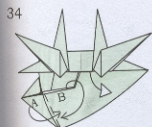

Pull the loose paper out from the interior as far as possible. Simultaneously bring points A and B together.

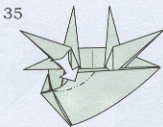

Push in the shell here to make the underside rounded.

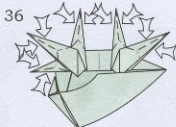

Pinch all the points.

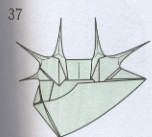

Like this. Turn the paper over.

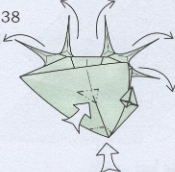

Sink the corners of the shell and curve the points.

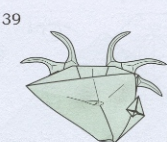

Spider Conch

Cuttlefish

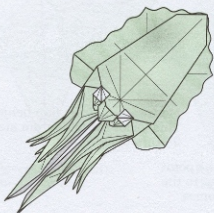

The Cuttlefish (*Sepia officinalis*), like other octopi and squid, possesses a reservoir of ink. When threatened by a predator, it ejects a blob of the ink and speeds away, leaving the predator to attack the squid-shaped globule. The ink of the cuttlefish is the original source of the dye sepia. The shell of the cuttlefish is an internal plate, which is harvested and sold as the "cuttlebone" often found in bird cages. It is found widely throughout the Atlantic Ocean and Mediterranean Sea.

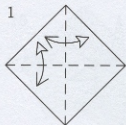

1 Fold and unfold.

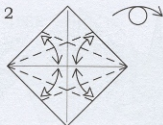

2 Fold and unfold.
Turn the paper over.

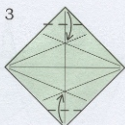

3 Fold the top and bottom corners to the intersections of the creases.

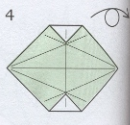

4 Like this. Turn the paper over.

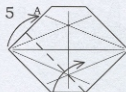

5 Fold the lower left edge up to point A.

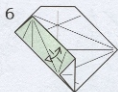

6 Fold and unfold, making a crease only where shown.

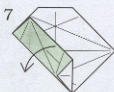

7 Unfold.

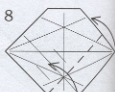

8 Repeat steps 5-7 on the right.

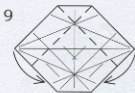

9 Repeat steps 5-7 on both sides of the top. Turn the paper over.

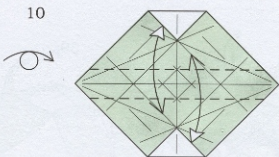

10 Fold and unfold through the creases, then rotate 1/4 turn.

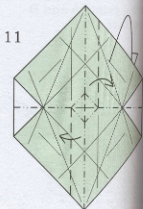

11 Fold, using the existing creases.

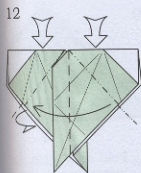

Squash-fold in front and back.

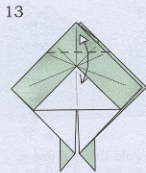

Fold and unfold.

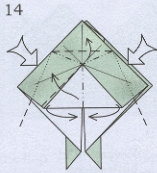

Swivel the sides in, bring the bottom corners of the white triangle together, and swing it over to one side.

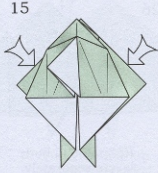

Repeat behind.

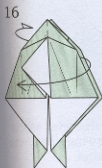

Fold one layer to the left in front and one to the right in back.

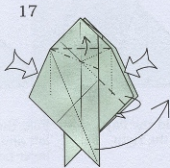

Swivel similarly to step 14.

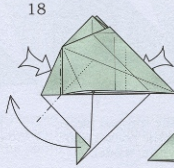

Repeat behind.

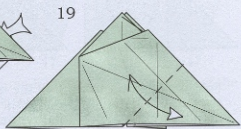

Enlarged view. Fold and unfold.

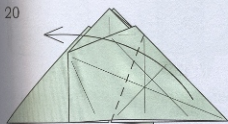

Fold the corner up to the left.

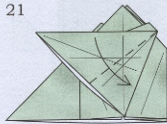

Fold the corner down to lie along the crease you just made.

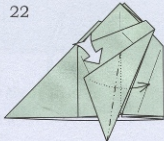

Reverse-fold both layers together.

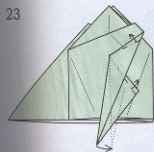

Shift the point so that its left edge becomes vertical.

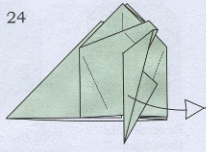

Unfold the flap.

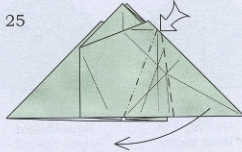

Crimp the flap symmetrically on the creases made in step 23.

26

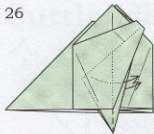

Reverse-fold both layers separately.

27

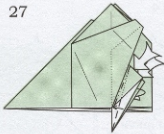

Reverse-fold both edges.

28

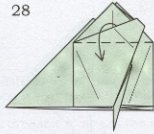

Fold the flap down as far as it will go.

29

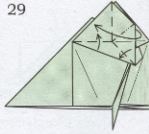

Fold it back up, incorporating the reverse fold shown.

30

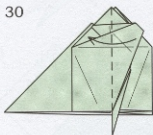

Fold the flap over to the left; it will not go all the way.

31

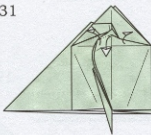

Pull the trapped paper out of the pocket and flatten the model.

32

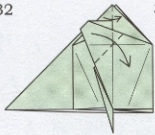

Fold the flap down to the right.

33

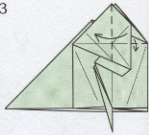

Fold the flap over to the left and swing down one layer behind.

34

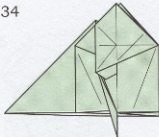

Repeat steps 19–33 on the back.

35



Fold one layer to the right in front and one to the left in back.

36



Squash-fold the white triangle.

37



Petal-fold.

38



Unwrap the loose paper.

39



Squash-fold.

40

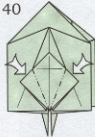

Reverse-fold the edges.

41

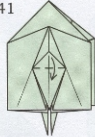

Fold the small point down.

42



Pull the front layers down and spread-squash the point.



In progress.

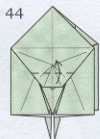

Fold a single flap upward as far as possible.

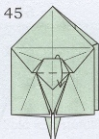

Fold the flap down again.



Sink the flap inside the model.

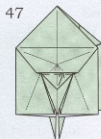

Tuck the flap up inside the pocket.

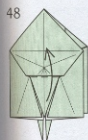

Fold the flap up.

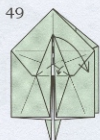

Fold a rabbit ear.



Enlarged view. Squash-fold the point.

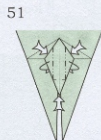

Reverse-fold the sides so they are parallel, and sink the tip of the point.

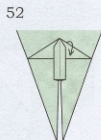

Tuck the top of the point into the pocket behind it.



Squeeze the sides of the funnel to round it.

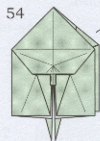

Like this. Turn the paper over.



Repeat steps 36-40 on this side.

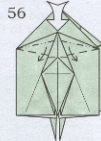

Spread-squash the point similarly to step 42 (note that the valley fold is higher here).

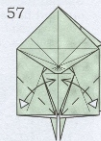

Fold and unfold.



Fold and unfold.

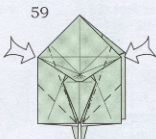

Reverse-fold each side in and out, using the existing creases.

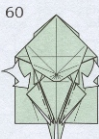

Reverse-fold the edges.

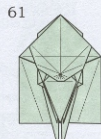

Repeat steps 57-60 behind.



Fold and unfold.

63

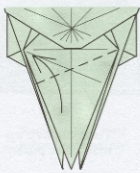

Enlarged view.
Fold the point up.

64

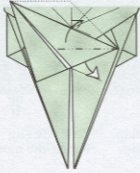

Pull out the
loose paper.

65

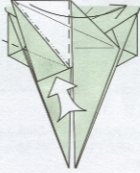

Squash-fold.

66

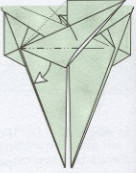

Pull out the
loose paper.

67

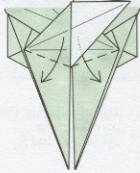

Spread the point
out and flatten it.

68

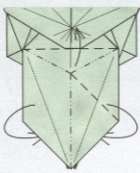

Squeeze the sides in
and swing the point
over to the right.

69

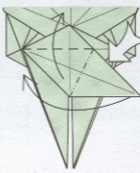

Squash-fold.

70

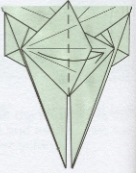

Fold one layer
over to the right.

71

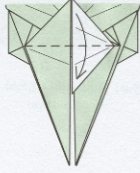

Fold the
point down.

72

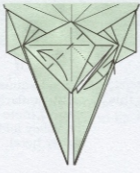

Spread the points
out to either side.

73

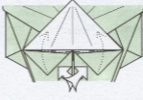

Reverse-fold the
edges upward.

74



Fold and unfold.

75



Fold and unfold.

76



Fold and unfold.

77



Fold two interlocking
rabbit ear folds using
the existing creases.

78



Reverse-fold
the two edges.

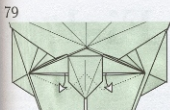

Pull out a single layer of paper on each side.

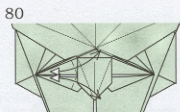

Fold and unfold.

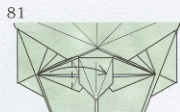

Fold over to the right.

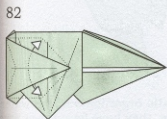

Enlarged view. Pull out the loose paper.

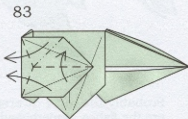

Fold a rabbit ear.

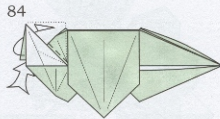

Reverse-fold.

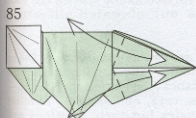

Repeat steps 80-84 on the right.



Bring the blunt point forward, but keep it behind the white eyes.

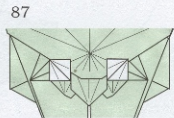

Like this.

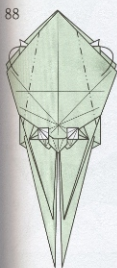

Mountain-fold the edges into the model; repeat behind.



Pinch each of the eight short legs using rabbit ears.

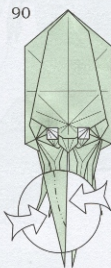

Flatten slightly the two longer legs.

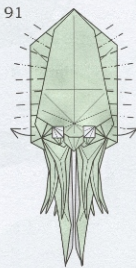

Pull the paper at the sides outward and upward a bit and curve it back and forth to make the edge ripple.

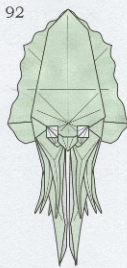

Cuttlefish

Fishes

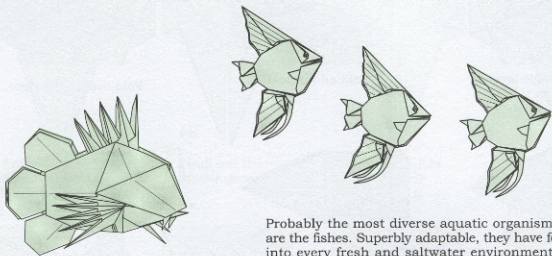

Probably the most diverse aquatic organisms in the water are the fishes. Superbly adaptable, they have found their way into every fresh and saltwater environment in the world. Fishes near the poles produce an antifreeze protein, while those living in oxygen-poor waters have developed primitive lungs and gulp air from the surface. Some species can even survive for long periods out of water altogether.

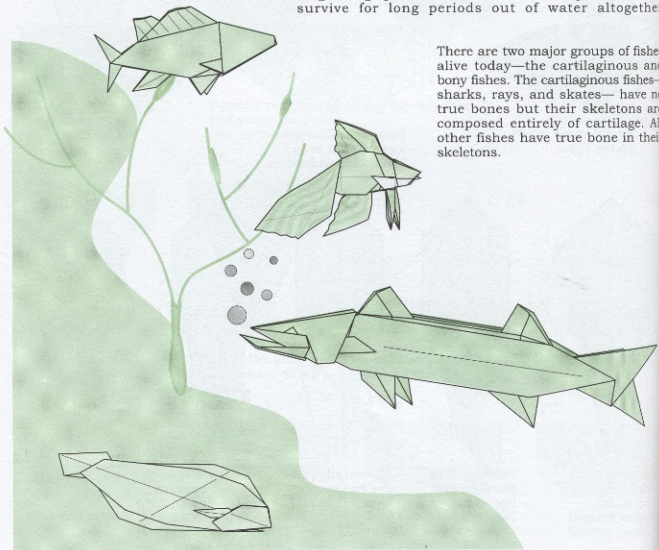

There are two major groups of fishes alive today—the cartilaginous and bony fishes. The cartilaginous fishes—sharks, rays, and skates—have no true bones but their skeletons are composed entirely of cartilage. All other fishes have true bone in their skeletons.

Ray

Skates and rays (order *Rajiformes*) are flat-bodied cartilaginous fish with wide pectoral fins that give their body the appearance of a flattened disk or polygon. Some species have venomous spines at the base of their tail.

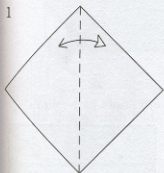
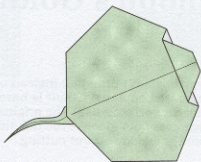

1 White side up. Fold and unfold along the diagonal.

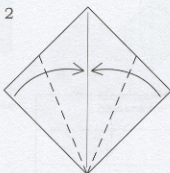

2 Fold the lower edges in to meet along the center line.

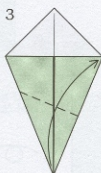

3 Fold the bottom corner up to the right corner.

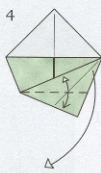

4 Fold and unfold the flap; then unfold to step 3.

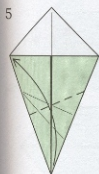

5 Repeat steps 3-4 on the other side.

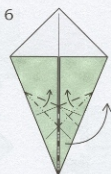

6 Fold a double rabbit ear on the existing creases.

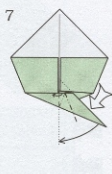

7 Fold a double rabbit ear on the existing creases.

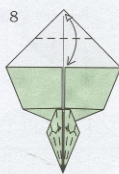

8 Fold the top point down and unfold. Fold the sides of the tail in thirds on left and right.

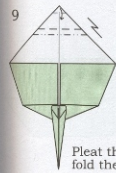

9 Pleat the top and fold the tip down.

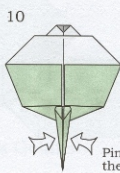

10 Pinch and curve the tail. Turn over.

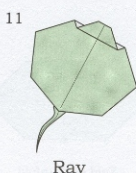

Ray

Tokinobu's Goldfish

This fish is a bit unusual: instead of being based on a real fish, it is based on another origami fish! The original design uses cuts to make the tail; this version is folded without cutting.

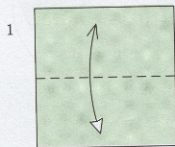
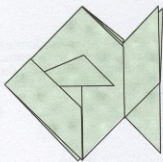

Fold and unfold.

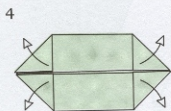
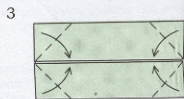
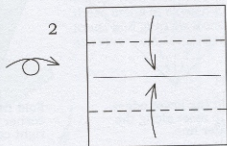

Unfold.

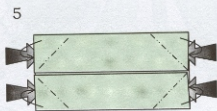

Make reverse folds.

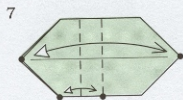
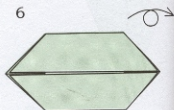

Fold and unfold.

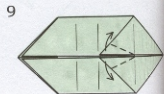
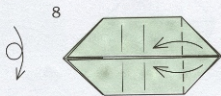

10

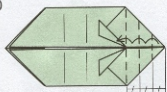

Fold in thirds.

11

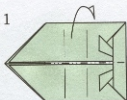

12

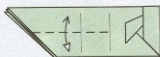

Fold and unfold.

13

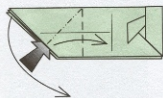

Valley-fold along the crease for this squash fold.

14

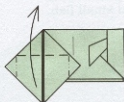

Mountain-fold along the creases for this petal fold.

15

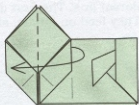

16

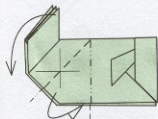

Crimp-fold. Rotate.

17

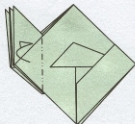

Tuck inside.
Repeat behind.

18

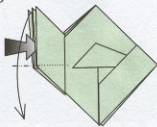

Reverse-fold the middle flap.

19

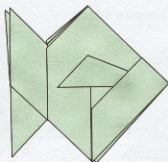

Tokinobu's Goldfish

Perch

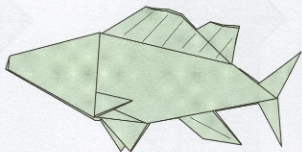

Perch (*Percidae*) are freshwater fish that live in lakes, ponds, and near the shore. They weigh about one to five pounds. They have rough scales and two dorsal fins. The first dorsal fin is sharp and spiny. They feed on larvae, shrimp, crab, and small fish.

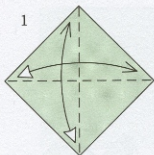

1

Fold and unfold along the diagonals.

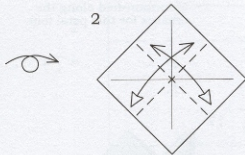

2

Fold and unfold.

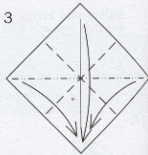

3

Collapse along the creases.



4

Kite-fold.

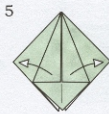

5

Unfold.

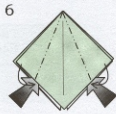

6

Reverse folds.

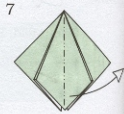

7

Unfold.

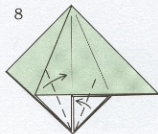

8

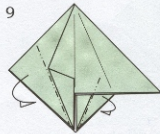

9

Kite-fold behind.

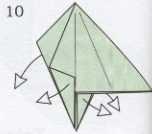

10

Unfold to step 8.

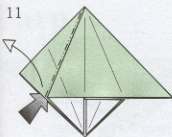

Pull out.

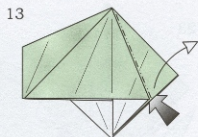
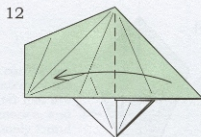

Pull out.

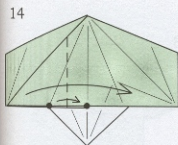

The dots will meet.

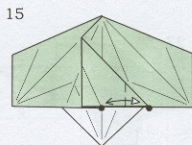

Fold and unfold.

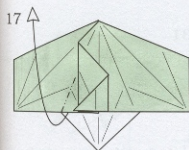
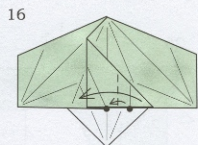

Unfold.

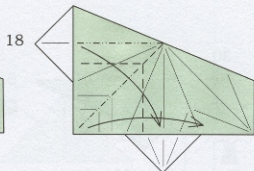

Fold along the creases.

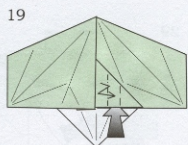

Crimp-fold along the creases.

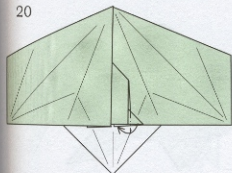

Reverse-fold.

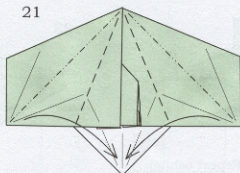

Squash-fold along the creases.
Fold behind the fin on the right.

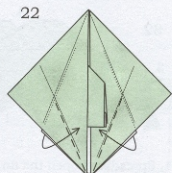

Valley-fold the hidden
layers inside.

23

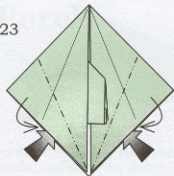

Reverse folds.

24

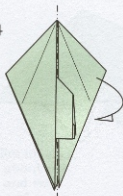

Fold in half and rotate.

25

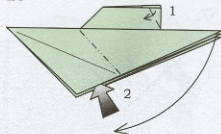

1. Repeat behind.
2. Reverse-fold.

26

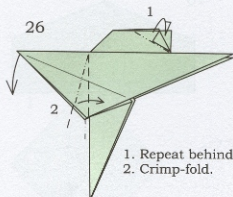

1. Repeat behind.
2. Crimp-fold.

27

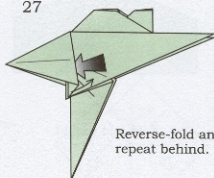

Reverse-fold and repeat behind.

28

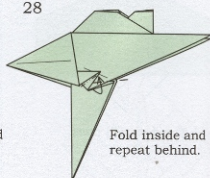

Fold inside and repeat behind.

29

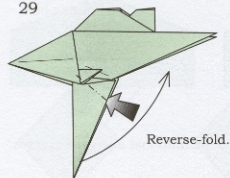

Reverse-fold.

30



Crimp-fold.

31



1. Outside-reverse-fold.
2. Repeat behind.

32

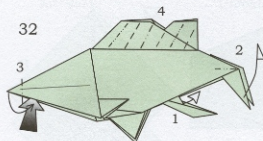

1. Spread and open the fin. Repeat behind.
2. Fold one layer up.
3. Reverse-fold.
4. Plect the fins.

33

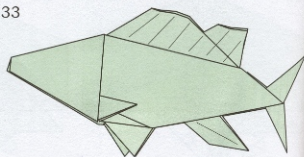

Perch

Carp

The carp or koi (*Cyprinus carpio*) has been genetically manipulated by the Japanese. These freshwater fish are found in Europe, North America, and Asia. They are most commonly found in ornamental pools and attain a length of two feet or more. These fish feed on tiny plants and animals in the mud.

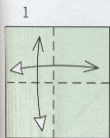
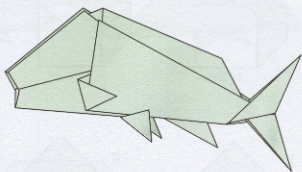

1
Fold, unfold,
and turn over.

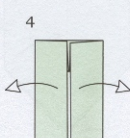
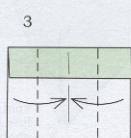
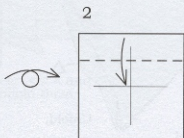

4
Unfold.

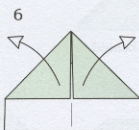
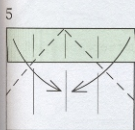

6
Unfold.

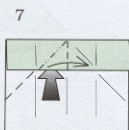

7
Squash-fold.

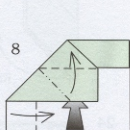

8
Squash-fold.

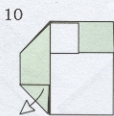

10
Unfold.

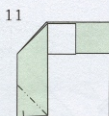

11
Reverse-fold.

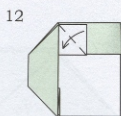

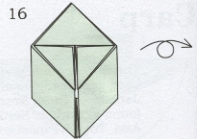
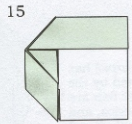
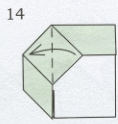
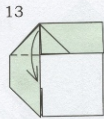

Repeat steps 7-14 on the right side.

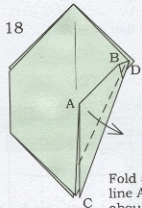
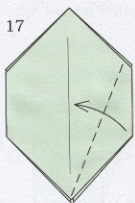

Fold so that line A-B is about parallel to line C-D.

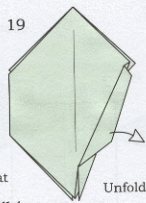

Unfold.

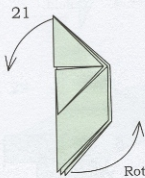
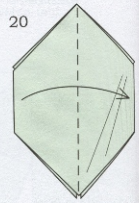

Rotate the model.

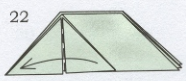

Do not repeat behind.

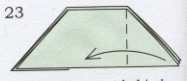

Do not repeat behind.

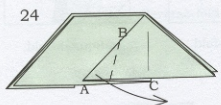

Fold so that some point between line A-B touches point C.

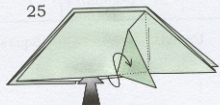

Place the paper above the darker region.

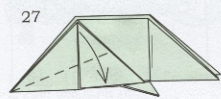
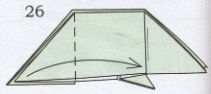

Repeat behind.



Squash-fold. Repeat behind.

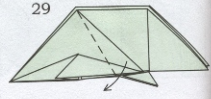

Repeat behind.

30

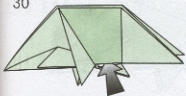

Bring the dark paper to the front. Repeat behind.

31



32



Unfold.

33

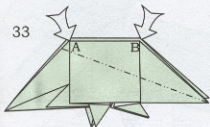

Sink. Push in corners A and B but do not unfold them.

34

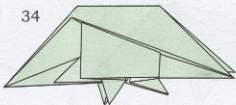

35

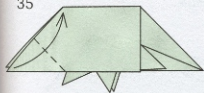

36



37

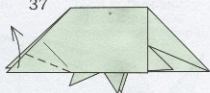

Unfold.

38

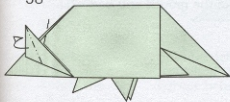

Reverse-fold.

39

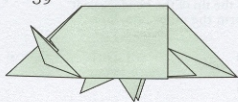

40

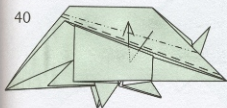

Tuck inside while folding along the creases.

41

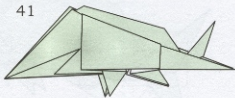

42

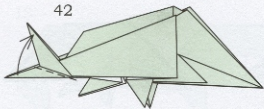

43

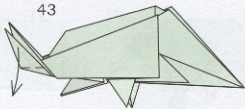

44

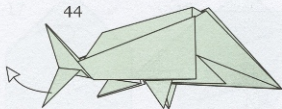

Unfold.

45

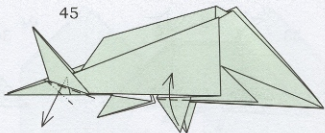

Tuck the tip of the base of the tail inside. Repeat behind for the fin.

46

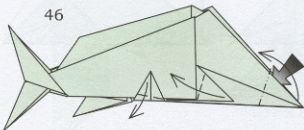

Reverse-fold the tip of the head. Repeat behind to form the other fins.

47

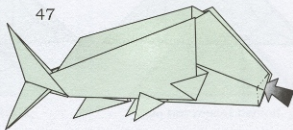

Make the mouth and body 3D.

48

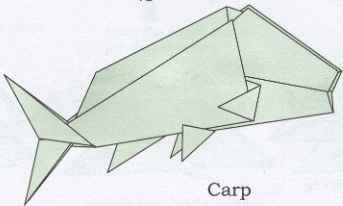

Carp

Brill

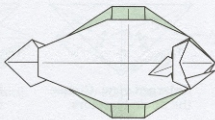

The Brill (*Scophthalmus rhombus*) is a variety of flatfish, a fish who, shortly after hatching, begins to lean to one side—the right side, in this case. As it leans, the right eye migrates to the upper side of the body, which assumes a dark coloration, and the fish eventually lies on the ocean's sandy bottom, its lighter side down. There are two groups of flatfishes—left-eyed and right-eyed—and by folding this model backwards, you can change this model to a fish of the opposite handedness.

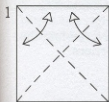

1 Crease the diagonals.

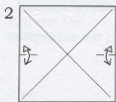

2 Make pinch marks halfway down the sides.

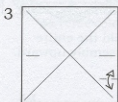

3 Bring the bottom right corner to the crease, pinch, and unfold.

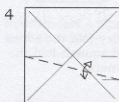

4 Fold the top and bottom corners to meet at the point where the crease crosses the diagonal.

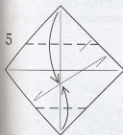

5 Connect the two pinch marks with a crease. Rotate the paper 1/8 turn counterclockwise.

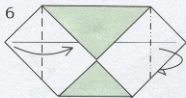

6 Fold the left corner in front and the right corner behind.

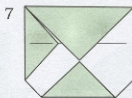

7 Turn the paper over.

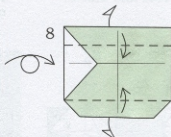

8 Fold the top edge down to the center line, allowing the point behind to flip up. Fold the bottom up similarly.

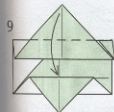

9 Fold down.

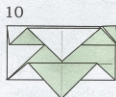

10 Turn the paper over.

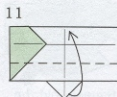

11 Fold the bottom edge upward.

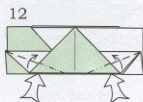

12 Reverse-fold.

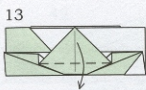

Fold down.

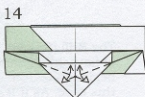

Crease the angle bisectors.

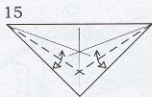

Enlarged view. Crease the angle bisectors.

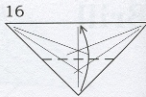

Fold the point up to the top edge.

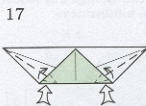

Valley-fold the edges and squash-fold the corners.

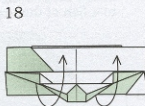

Fold the entire assembly upward.

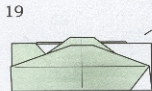

Turn the paper over.

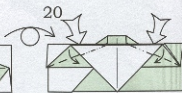

Reverse-fold the corners.

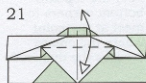

Fold and unfold.



Repeat steps 14-17 on this flap.

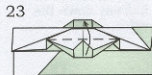

Fold upward.

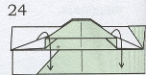

Fold the entire assembly downward.

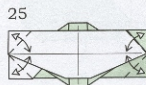

Fold and unfold.

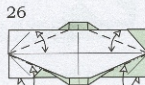

Fold and unfold.

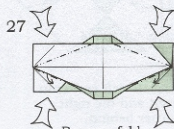

Reverse-fold.

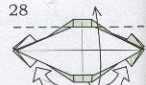

Lift up the top layers.

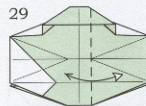

Fold and unfold.

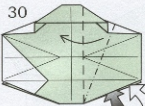

Squash-fold the top layers.

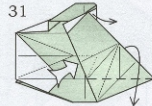

Swing the right side down, incorporating a hidden crimp. The model will not lie flat.

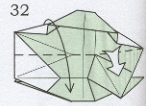

Close the model up and flatten it.

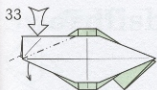

Reverse-fold (again).

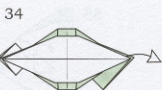

Undo steps 28-33.

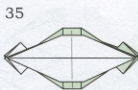

Turn over from top to bottom.

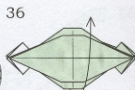

Repeat steps 28-33 on the left.



Refold the right side to step 34.



Pull out the trapped paper.

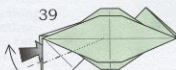

Reverse-fold.

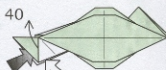

Reverse-fold a single layer upward.

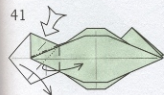

Squash-fold asymmetrically.



Turn the model over.

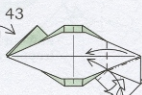

Squash-fold.

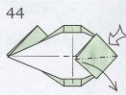

Squash-fold.

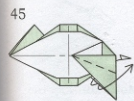

Outside-reverse-fold. Turn the model over.

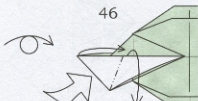

Enlarged view. Squash-fold.



Swivel-fold.

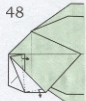

Shift the swivel fold slightly to the right.

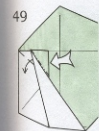

Enlarged view. Reverse-fold.

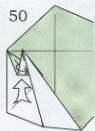

Swivel-fold and tuck inside the pocket.



Mountain-fold the flap into the pocket behind.

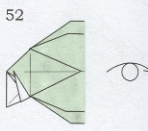

Like this. Turn the model over.

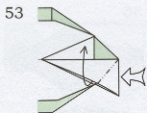

Squash-fold.

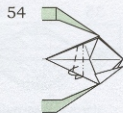

Crimp. Repeat behind.

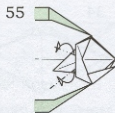

Shape the fin. Repeat behind.

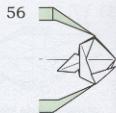

Like this.

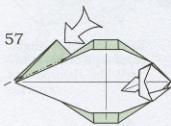

Reverse-fold.

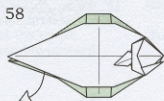

Pull out the trapped corner.

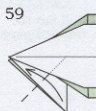

Valley-fold.

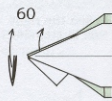

Fold one pair of layers up from the inside.

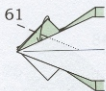

Valley-fold.

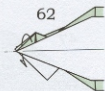

Fold one layer down.

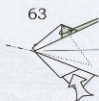

Enlarged view of tail. Reverse-fold the edge.



Mountain-fold the point into the pocket.

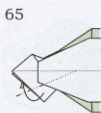

Repeat steps 61-64 on the bottom of the other side.

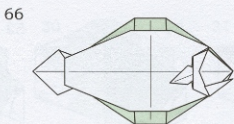

Turn the model over.

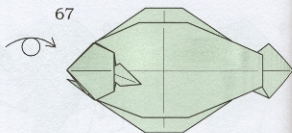

Brill

Swordfish

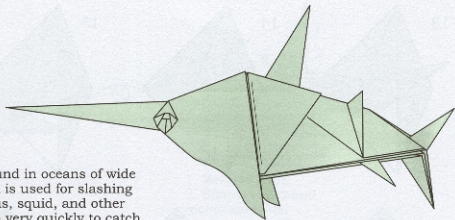

Swordfish (*Xiphias gladius*) are found in oceans of wide ranging temperatures. The sword is used for slashing its prey, which consists of octopus, squid, and other fish. They are agile and can swim very quickly to catch their prey. They also have a heating organ by their eyes and brain, allowing for better vision to attack prey.

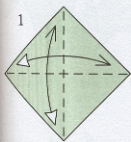

1 Fold and unfold.

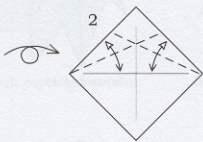

2 Fold and unfold.

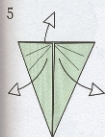
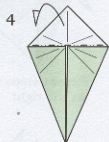
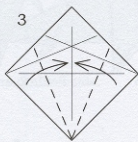

5 Unfold.

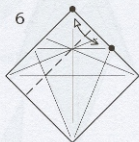

6 Fold and unfold.

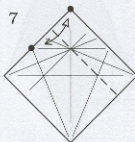

7 Fold and unfold.

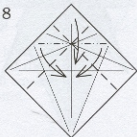

8 Collapse along the creases.

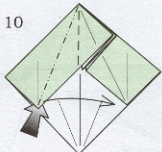
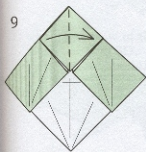

10 Squash-fold.

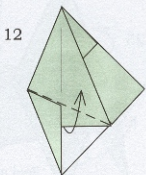
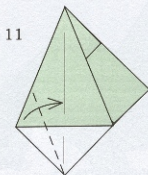

12 Pull out.

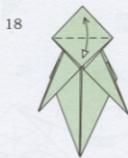
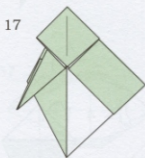
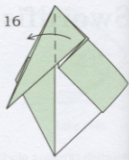
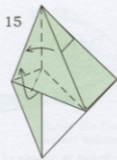
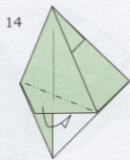
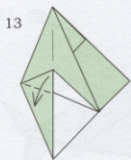

Repeat steps 9–16
on the right.

Fold up and unfold.

Squash-fold.

Reverse folds.

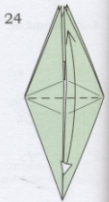
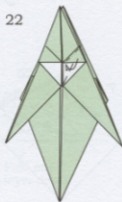
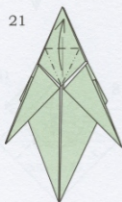

Petal-fold.

Fold on the right.

Fold and unfold.

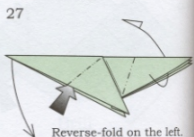
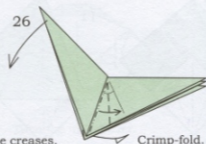
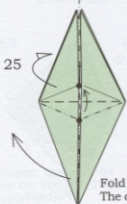

Fold along the creases.
The dots will meet. Rotate.

Crimp-fold.

Reverse-fold on the left.

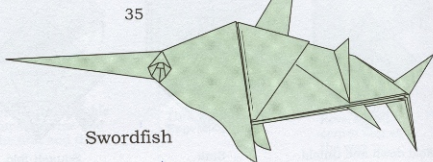
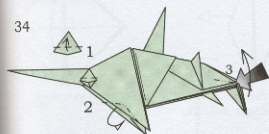
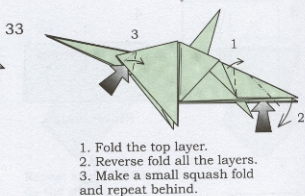
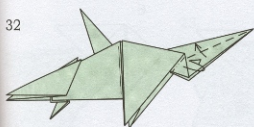
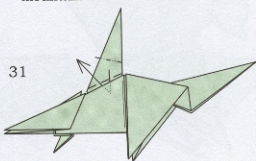
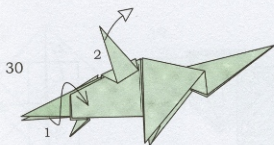
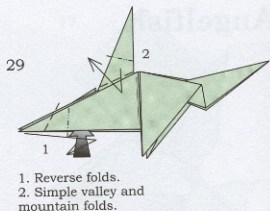
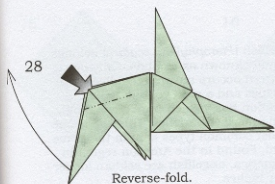

Angelfish

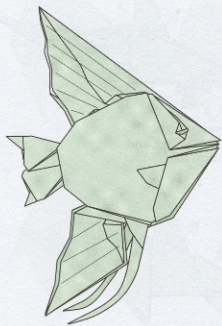

The angelfish (*Pterophyllum scalara*) belongs to the family known as cichlids. Only one color pattern occurs naturally— silver with black stripes and a red eye, but genetic manipulation has yielded pure silver, gold, calico, and marbled varieties. This fish is one of the most common types kept in the home aquarium. Found in the Amazon region in South America, angelfish are seldom longer than four inches.

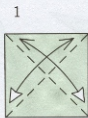

1
Fold and unfold.

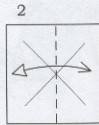

2
Fold and unfold.

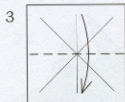

3

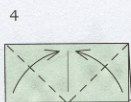

4

Repeat behind.

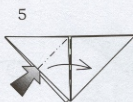

5

Squash-fold.

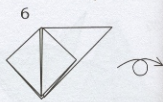

6

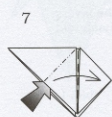

7

Squash-fold.

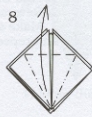

8

Petal-fold.
Repeat behind.

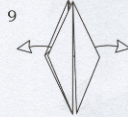

9

Pull out the loose paper.
Repeat behind.

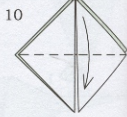

10

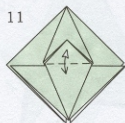

11

Fold down and unfold.

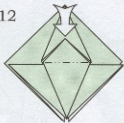

12

Sink.

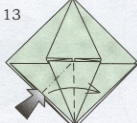

13

Squash-fold.



14

Reverse-folds.

15

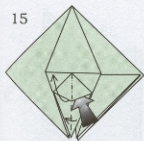

16

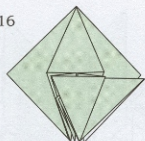

17

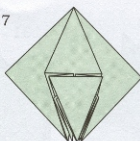

Repeat steps 13-15
on the right.

18

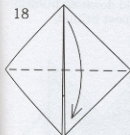

19

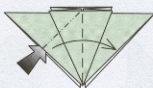

Squash-fold.

20

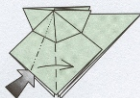

Squash-fold.

21

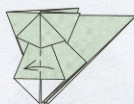

22

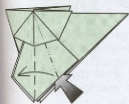

Squash-fold.

23

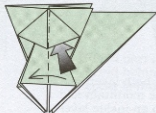

24

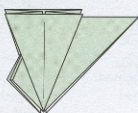

Repeat steps 19-23
on the right.

25



26

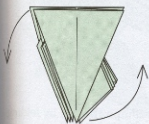

Rotate the model.

27

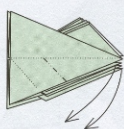

Of the three inside
flaps, reverse-fold
the first and third.

28

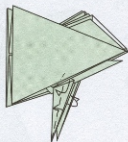

Thin the fins.
Repeat behind.

29

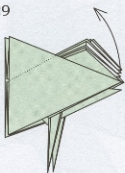

Reverse-fold the
center flap all
the way up.

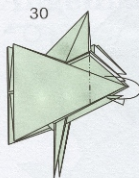

Repeat behind.

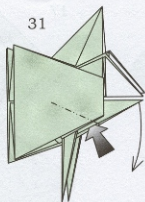

Reverse-fold.

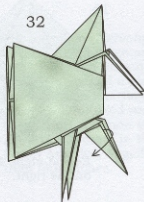

Repeat behind.

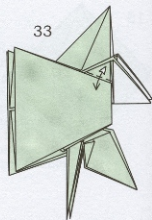

Fold down and unfold.
Repeat behind.

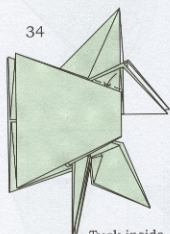

Tuck inside.
Repeat behind.

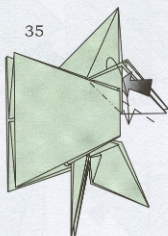

Reverse-fold both layers
together. The mountain fold
line refers to an inside layer.

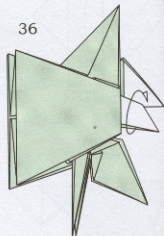

Fold the paper
inside-out.

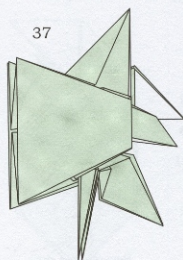

Repeat steps
35-36 behind.

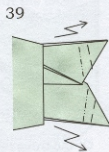
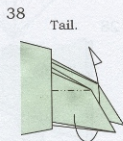

Crimp-folds.

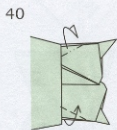

Shape the tail by folding
a little bit of the top part
behind and the bottom
part in front.

41



Reverse-folds.
Repeat behind.

42

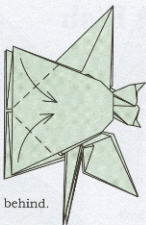

Repeat behind.

43

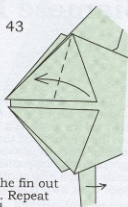

Slide the fin out
a little. Repeat
behind.

44

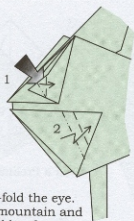

1. Squash-fold the eye.
2. Simple mountain and
valley-fold to form
a fin.
Repeat behind.

45

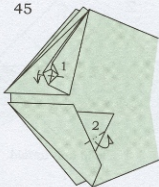

1. Fold part of the eye down.
2. Fold behind to shape the fin.
Repeat behind.

46

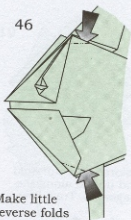

Make little
reverse folds
at the top and
bottom. Repeat
behind.

47

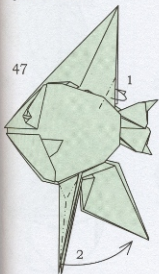

1. Mountain-fold.
2. Double-rabbit-ear the fins.
Repeat behind.

48

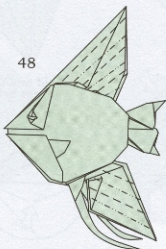

Pleat the fins.

49

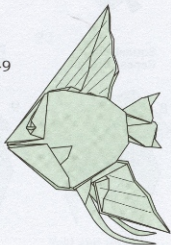

Angelfish

Siamese Fighting Fish

The Siamese Fighting Fish (*Betta splendens*) is a popular aquarium fish because of its bright colors and often elaborate fins, which have been enhanced through selective breeding by enthusiasts. Males are very aggressive (as the name suggests) and readily attack one another; they will even attack their own reflection in a mirror.

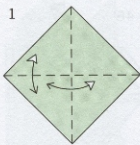
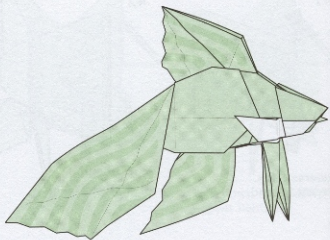

Colored side up. Fold and unfold along the diagonals. Turn over.

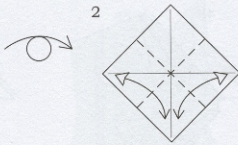

Fold and unfold.

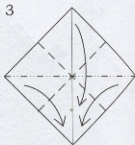

Fold a Preliminary Fold.

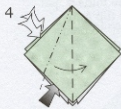

Squash-fold.
Repeat behind.

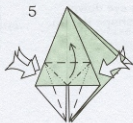

Petal-fold.
Repeat behind.

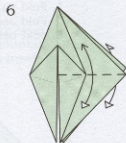

Fold and unfold.
Repeat behind.

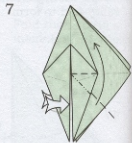

Squash-fold.
Repeat behind.



Squash-fold.
Repeat behind.



Petal-fold.
Repeat behind.



Open-sink.
Repeat behind.

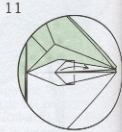

Fold the point to the right. Repeat behind.

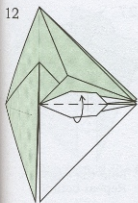

Fold the layers up only on the near side.

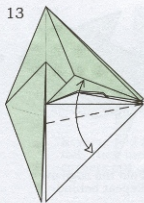

Fold and unfold.

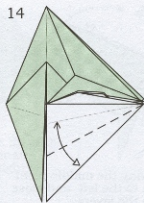

Fold and unfold.

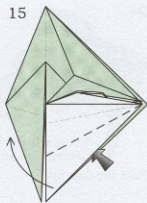

Reverse-fold on the existing crease.

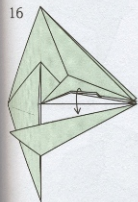

Fold all the white layers down. Repeat behind.

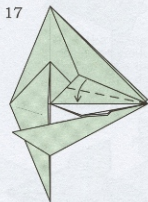

Fold the colored edge down. Repeat behind.

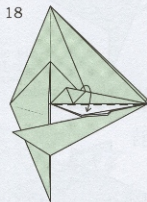

Fold the colored edge down. Repeat behind.

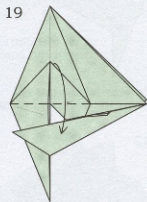

Fold the point down. Repeat behind.

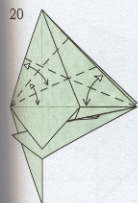

Fold and unfold through all layers, both directions.

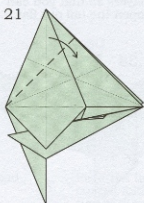

Fold the top over to the right.

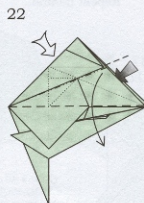

Squash-fold. A gusset forms in the inner layers.

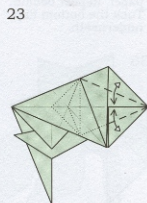

Fold and unfold. Xray lines show the hidden gusset.

24

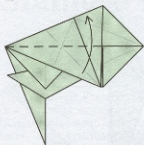

Fold the flap up.

25

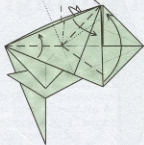

Swing the middle point up to the left and close up the layers.

26

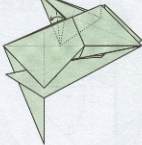

Fold the edge over. Repeat behind.

27

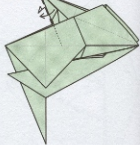

Fold the edge over. Repeat behind.

28

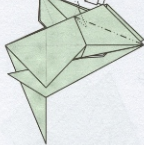

Reverse-fold. A gusset forms in the inner layers.

29

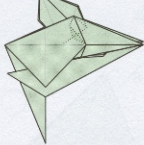

Like this. The hidden gusset is shaded.

30

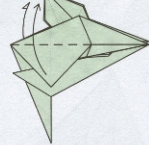

Fold a flap up. Repeat behind.

31

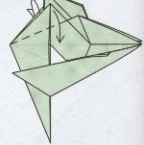

Fold the corner down. Repeat behind.

32

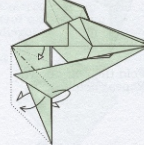

Pull out some loose paper. Repeat behind. Tuck the bottom flap underneath.

33

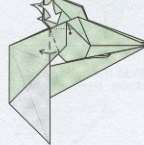

Swivel-fold. Repeat behind.

34

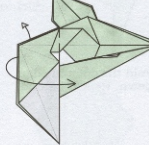

Release the trapped layers so that you can open the tail out flat.

35

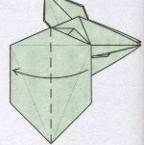

Close it back up.

36

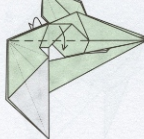

Fold a flap down. Repeat behind.

37

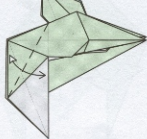

Fold and unfold. Repeat behind.

38

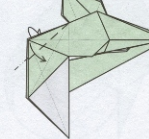

Fold to the crease you just made. Repeat behind.

39

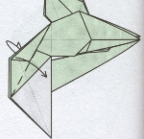

Fold on the existing crease. Repeat behind.

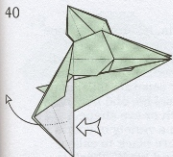

Unreverse-fold the flap.

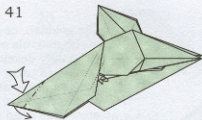

Reverse-fold the tip of the tail. Tuck two small corners out of sight.

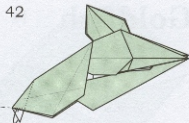

Tuck the tip of the tail inside.

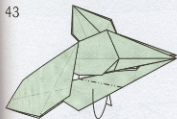

Mountain-fold the flap behind.

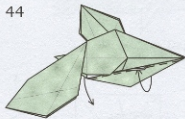

Tuck the triangle up inside the model, locking the two flaps together; the belly fin flips downward.

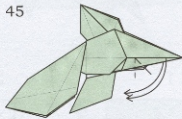

Crimp two long flaps downward.

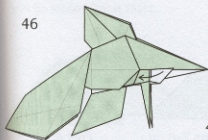

Fold the fin to the left. Repeat behind.

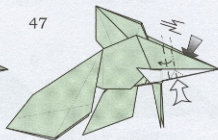

Crimp the head, making a dent in the inner bottom layers.

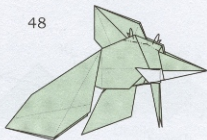

Mountain-fold the top edges of the body. Repeat behind.

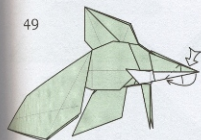

Crimp the tip of the head.

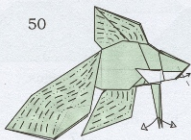

Pleat the large fins with curved folds. Spread the tips of the narrow points. Fold the lower jaw outward.

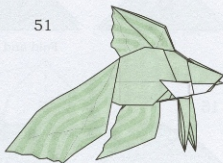

Siamese Fighting Fish

Goldfish

The goldfish, or oranda, (*Carassius*) is one of the marvels of genetic manipulation. Originally developed in China from small species of carp, the modern goldfish can have as many as four separate tails, may or may not have a dorsal fin, and may have grotesque head growth or eye shape. Goldfish also come in a variety of colors from pure white to pure black to calico. Although suited to pond life, this fish is generally better displayed in an aquarium or fishbowl. Goldfish can reach a length of about eight inches, not including the tail.

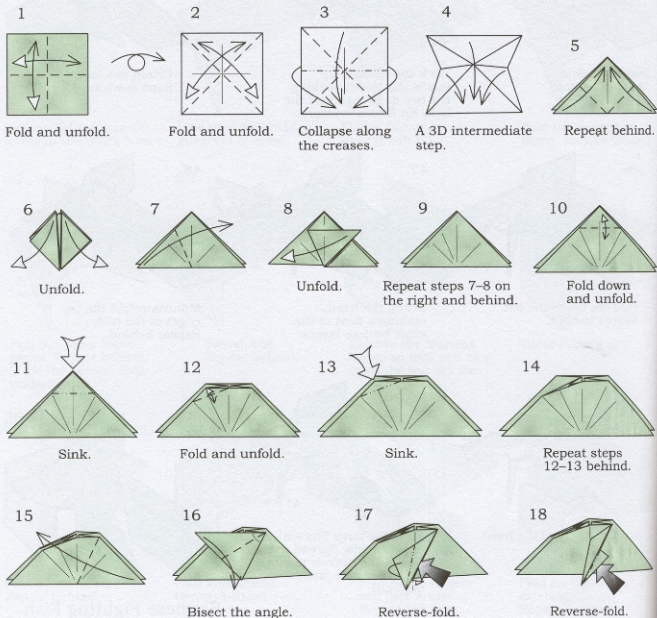
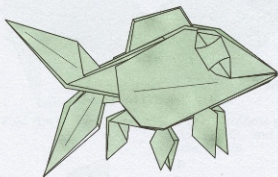

19



Unfold.

20

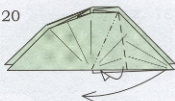

Crimp-fold.

21

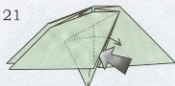

Reverse-fold.

22

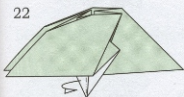

Repeat step 21.

23



Reverse-fold. Repeat on the other side.

24



Repeat steps 15-23 behind.

25

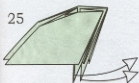

Unfold, repeat behind. This will be folded back later.

26



27



Squash-fold.

28



29



This is a 3D step.

30

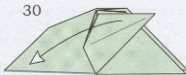

Unfold.

31

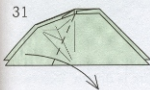

32

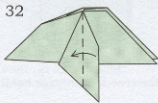

33

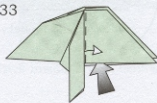

Pull out some paper.

34

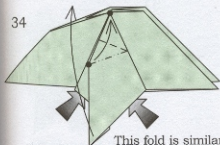

This fold is similar to a petal fold. The dots will meet.

35

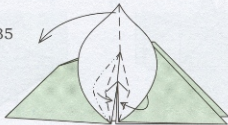

This is a 3D step.

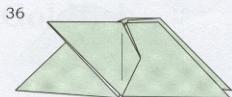

Repeat steps 26–35 behind.

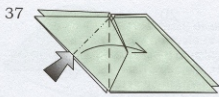

Squash-fold. Repeat behind.

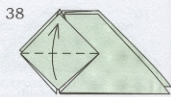

Unfold.

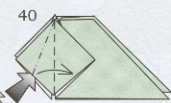

Squash-fold.

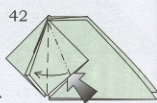
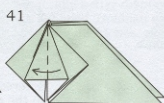

Squash-fold.

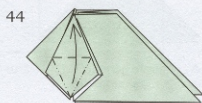
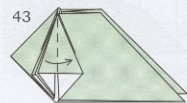

Petal-fold.

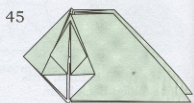

Repeat steps 38–44 behind.

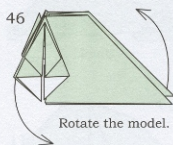

Rotate the model.

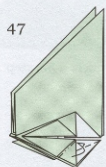

Reverse-fold, repeat behind.

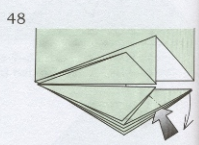

Only the bottom part of the figure is drawn. Reverse-fold.

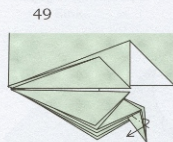

Spread the paper. Repeat behind.

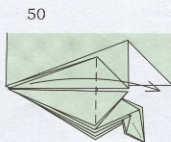

Repeat behind.

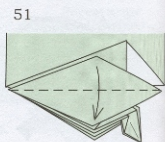

Repeat behind.

52

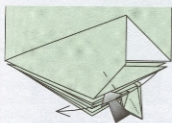

Reverse-fold, repeat behind.

53

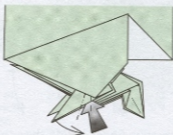

Squash-fold, repeat behind.

54

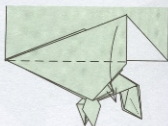

Repeat behind.

55

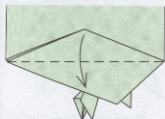

Repeat behind.

56

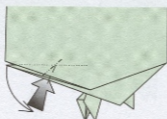
Squash-fold,
repeat behind.

57

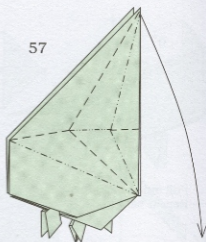
Refold along the creases formed in
steps 20-24. Repeat behind. Do
these folds slowly and carefully.

58

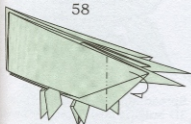

Tuck behind, repeat behind.

59

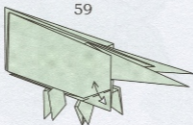
Fold up and unfold.
Repeat behind.

60

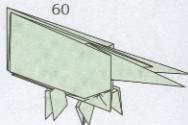

Tuck inside, repeat behind.

61

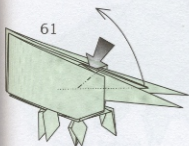
Reverse-fold the
middle flap up.

62

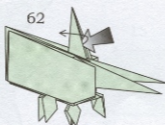
Fold the top layer to the
left. Repeat behind.

63

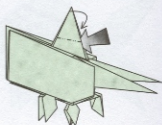

Reverse-fold.

64

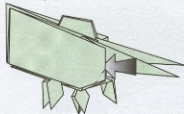

Reverse-fold,
repeat behind.

65

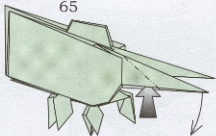

Place your finger inside the
center layer for this reverse
fold. Do not repeat behind.

66

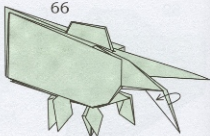

Pull paper out from the
inside of the tail. Repeat
behind on this flap.

67

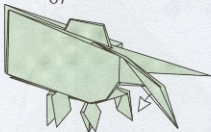

Pull out some paper.
Repeat behind.

68

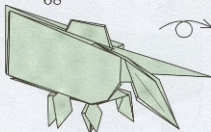

69

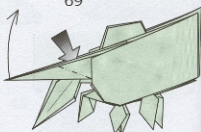

Place your finger inside
the second pocket for
this reverse fold.

70

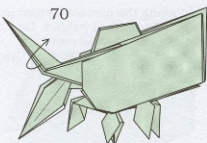

Slide the top layer up.

71

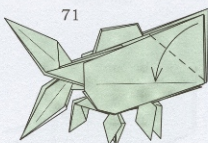

Repeat behind.

72

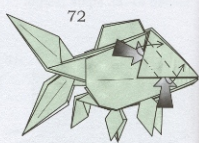

Spread-squash-fold to form a
3D bulging eye. Repeat behind.

73

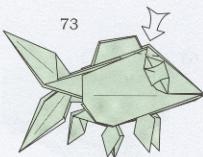

Reverse-fold at the top of
the head. Repeat behind.

74

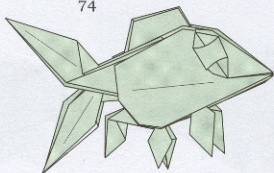

Goldfish

Barracuda

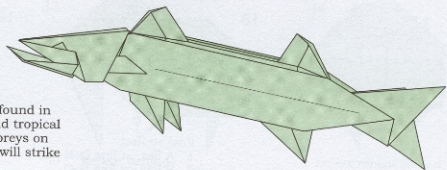

The barracuda (*Sphyræna*) is found in coastal lagoons, coral reefs, and tropical seas. Three to six feet long, it preys on smaller fish. This curious fish will strike at bright or moving objects.

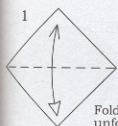

Fold up and unfold.

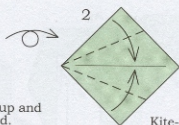

Kite-fold.

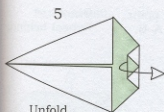
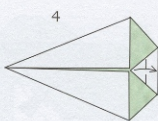
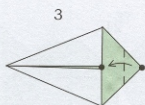

Unfold.

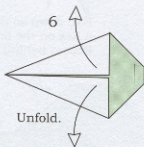

Unfold.

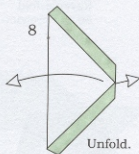
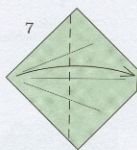

Unfold.

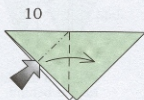
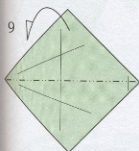

Squash-fold on the existing crease.

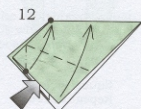
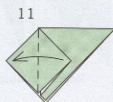

Valley-fold along the crease for this squash fold. Repeat behind.

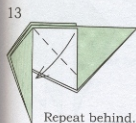

Repeat behind.

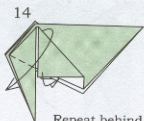

Repeat behind.

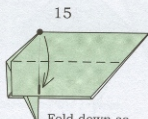

Fold down so that corner lies on the crease.

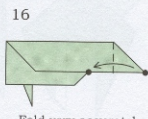

Fold very accurately.

17

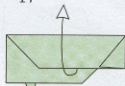

Fold up.

18

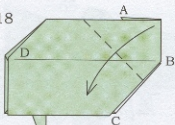

Fold so that

1. A lies on line D-B and
2. B lies on line B-C.

19

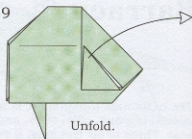

Unfold.

20

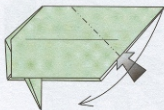
Reverse-fold
on the crease.

21

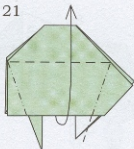
Petal-fold.
Repeat behind.

22

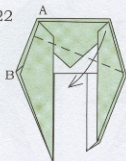
Fold down so that point
A lies on the line A-B.
Repeat behind.

23

Unfold.
Repeat behind.

24

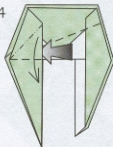
Squash-fold.
Repeat behind.

25

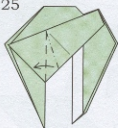

Repeat behind.

26

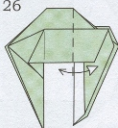
Fold and unfold.
Repeat behind.

27



Repeat behind.

28

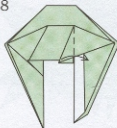

Repeat behind.

29



Repeat behind.

30

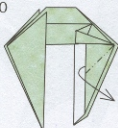
Pull some paper out.
Repeat behind.

31

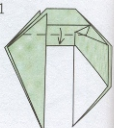

Repeat behind.

32



Open slightly so the dots meet. Repeat behind.

33

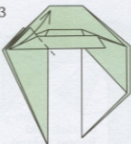

Repeat behind.

34

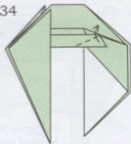

Do not repeat behind.

35

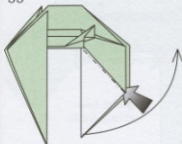

Reverse-fold.

36

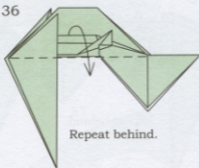

Repeat behind.

37

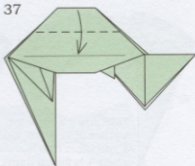

38

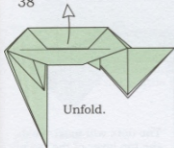

Unfold.

39

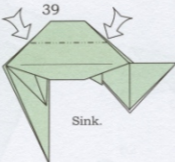

Sink.

40

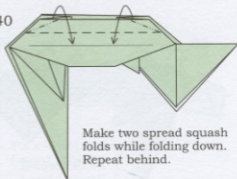

Make two spread squash folds while folding down. Repeat behind.

41

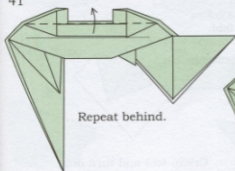

Repeat behind.

42

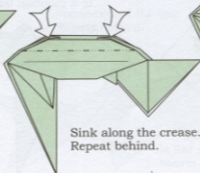

Sink along the crease. Repeat behind.

43

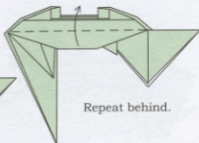

Repeat behind.

44

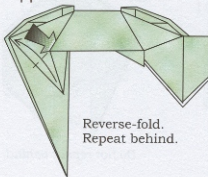

Reverse-fold.
Repeat behind.

45

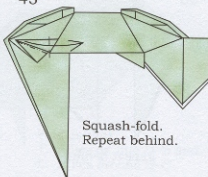

Squash-fold.
Repeat behind.

46

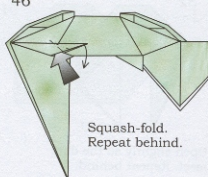

Squash-fold.
Repeat behind.

47

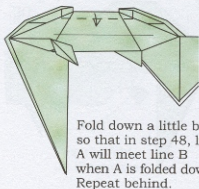

Fold down a little bit
so that in step 48, line
A will meet line B
when A is folded down.
Repeat behind.

48

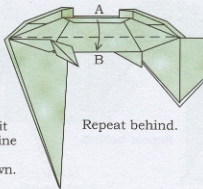

Repeat behind.

49

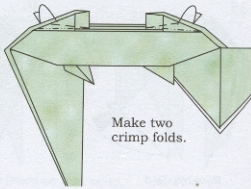

Make two
crimp folds.

50

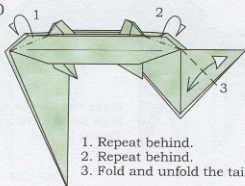

1. Repeat behind.
2. Repeat behind.
3. Fold and unfold the tail.

51

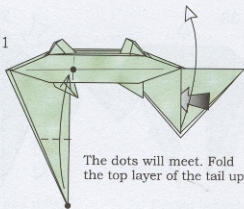

The dots will meet. Fold
the top layer of the tail up.

52

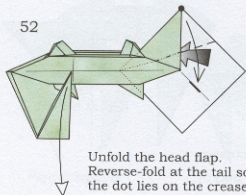

Unfold the head flap.
Reverse-fold at the tail so
the dot lies on the crease.

This x-ray line refers
to a mountain fold.

53

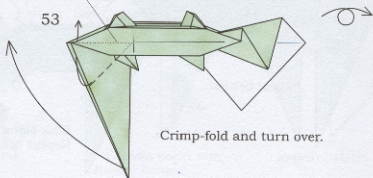

Crimp-fold and turn over.

54

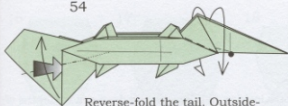

Reverse-fold the tail. Outside-reverse-fold the head using the dot as a guide.

55

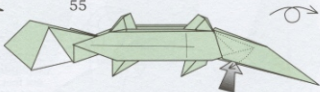

Reverse-fold the fin down. Turn over and repeat behind.

56

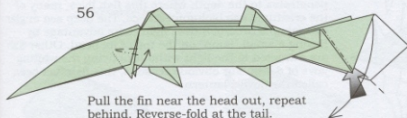

Pull the fin near the head out, repeat behind. Reverse-fold at the tail.

57

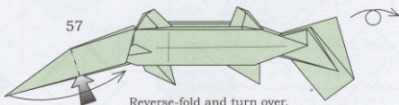

Reverse-fold and turn over.

58

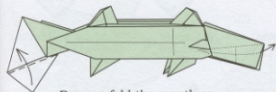

Reverse-fold the mouth so it sticks out a little bit.

59

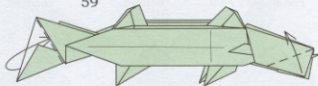

Tuck inside at the tail. Repeat behind at the head.

60 Head.



Unfold, repeat behind.

61

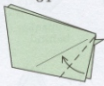

Repeat behind.

62



Formation of the eye. Repeat behind.

63



Repeat behind.

64

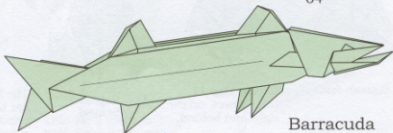

Barracuda

Deep Sea Angler Fish

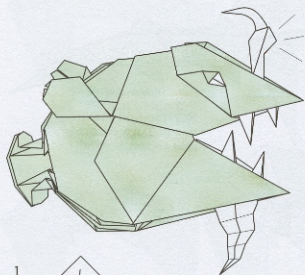

This scary looking fish lives in the deep sea at depths of two miles and more. It ranges in size from two inches to six feet. The majority of the fish is mouth and stomach, both of which are expandable and allow the fish to swallow a meal up to twice its own size. Because no light penetrates to the depth where this fish lives, many of the creatures use bioluminescence. The deep sea angler (*Linophryne arborifer*) uses light to its advantage by having a small "lamp" on the top of its head. Other fish are attracted to the light without noticing the waiting jaws of death. For obvious reasons, this fish has been called the devil's lantern.

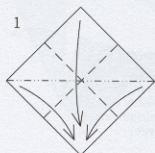

1
Begin with the Preliminary Fold.

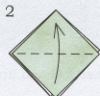

2
Fold up, repeat behind.



3
Unfold, repeat behind.



4
Repeat behind.



5
Fold up and unfold. Repeat behind.

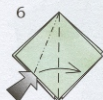

6
Squash-fold. Repeat behind.

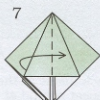

7
Repeat behind.



8
Squash-fold. Repeat behind.



9
Repeat behind.



10
Petal-fold. Repeat behind.



11
Squash-fold.



12
Repeat step 11 three times, on the right and behind.



13
Repeat behind.

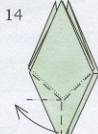

14
The folds for this rabbit ear lie below the thicker region, shown with the x-ray lines.



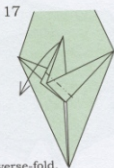

Reverse-fold.

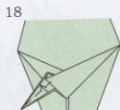

Make the flap white.
Repeat behind.

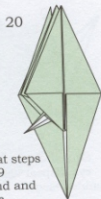

Repeat steps
14-19
behind and
rotate.

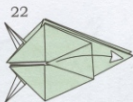
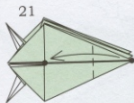

Unfold.

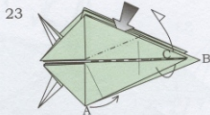

This fold will open the mouth. While folding C up, the corner A will end up along the line A-B. The x-ray line represents a valley fold in the hidden layers. Not only is this to be repeated behind, but it will not work otherwise.

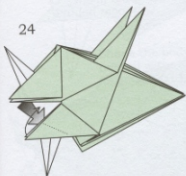

Reverse-fold one of the inner flaps to form a large white tooth on the lower jaw. Be sure to find the right layer to place your finger to make the tooth white.

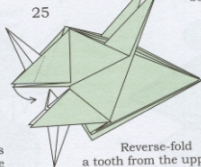

Reverse-fold
a tooth from the upper
jaw so it is in front of the
larger tooth.

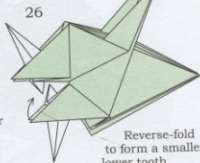

Reverse-fold
to form a smaller
lower tooth.

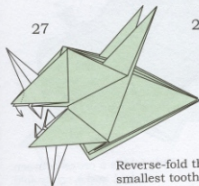

Reverse-fold the
smallest tooth.

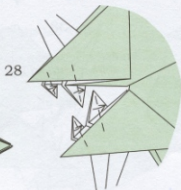

Thin each tooth in
half. Repeat behind.

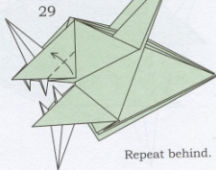

Repeat behind.

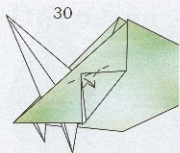

30

Squash-fold to form the eye. Repeat behind.

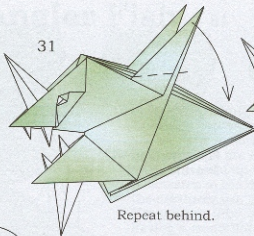

31

Repeat behind.

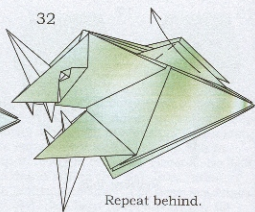

32

Repeat behind.

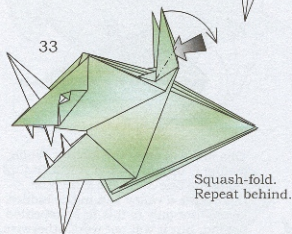

33

Squash-fold. Repeat behind.

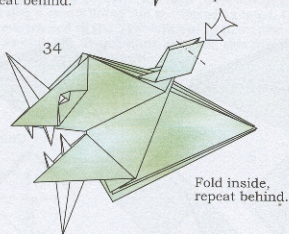

34

Fold inside, repeat behind.

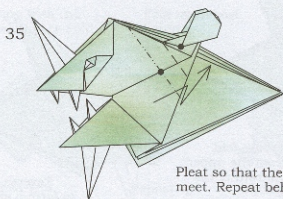

35

Pleat so that the dots meet. Repeat behind.

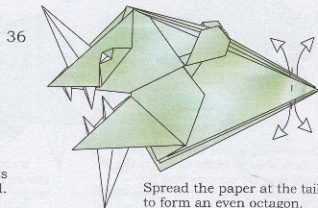

36

Spread the paper at the tail to form an even octagon.

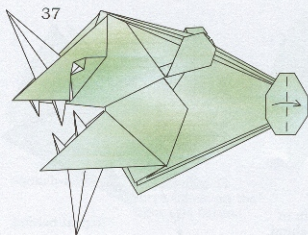

37

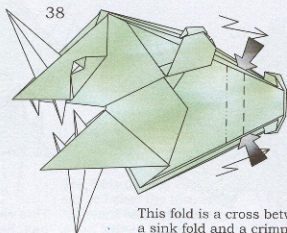

38

This fold is a cross between a sink fold and a crimp fold.

39

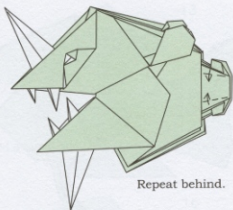

Repeat behind.

40

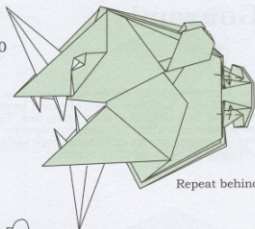

Repeat behind.

41

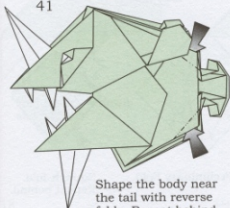

Shape the body near the tail with reverse folds. Repeat behind.

42

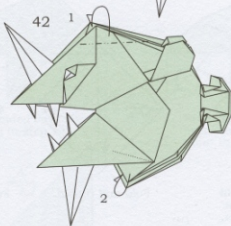

1. Mountain-fold at the top.
2. Mountain-fold on the x-ray line.

 Repeat behind.

43

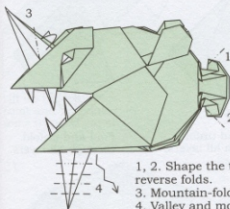

- 1, 2. Shape the tail with reverse folds.
3. Mountain-fold, repeat behind.
4. Valley and mountain folds.

46

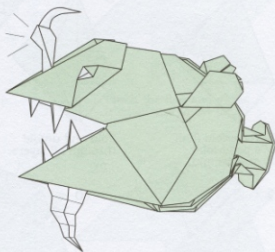

Deep Sea Angler Fish

44

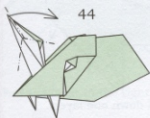

Double-rabbit-ear.

45

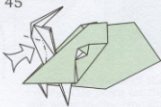

Make the lure 3D.

Gourami

The Gouramis (family *Osphronemidae*) are a large family of aquarium fish, many of which have elongated rays in front of their pelvic fins. They are popular aquarium fish and very diverse, with over 90 species known and many more variants developed through selective breeding.

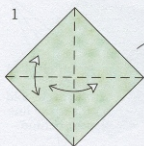
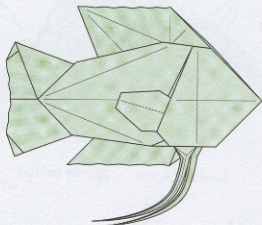

1 Colored side up. Fold and unfold along the diagonals. Turn over.

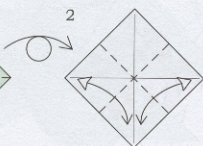

2 Fold and unfold.

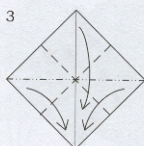

3 Fold a Preliminary Fold.



4 Squash-fold. Repeat behind.

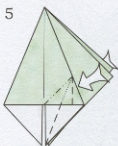

5 Reverse-fold (half of a petal-fold). Repeat behind.

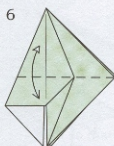

6 Fold and unfold through all layers.

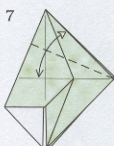

7 Fold and unfold through all layers.



8 Fold and unfold through all layers.

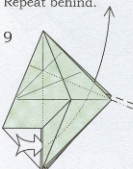

9 Reverse-fold the middle layer up on an existing crease.

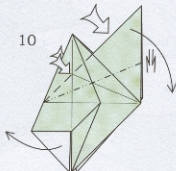

10 Crimp symmetrically.

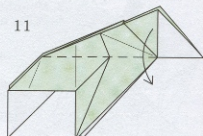

11 Fold down one layer.

12

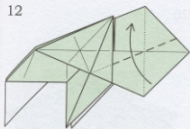

Fold a layer up.

13

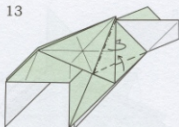

Tuck a folded edge inside.

14

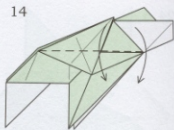

Fold two flaps down. The right flap will not lie flat.

15

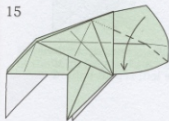

Fold the layer down and flatten.

16

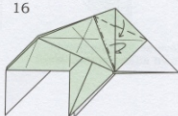

Tuck a folded edge inside as in step 14.

17

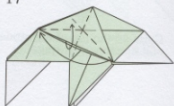

Spread the layers evenly and swing a point to the right.

18

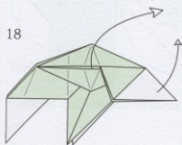

Lift up the white point and pull out some trapped paper.

19

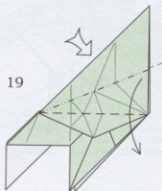

Squash-fold the flap.

20

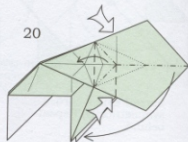

Pinch the flap and swing it down and to the left.

21

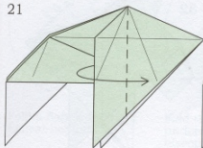

Fold the layer to the right.

22

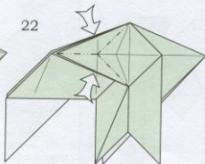

Push in the sides of the near layers. The point on the left will start to rise up.

23

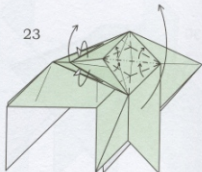

Form a Fish Base from the central square and swing two flaps up; the model will not lie fully flat.

24

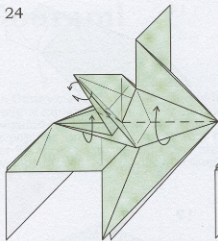

Close up the top of the model and flatten everything.

25

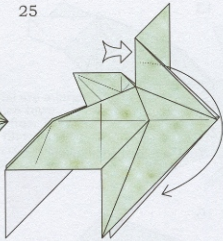

Reverse-fold the point down as far as possible.

26

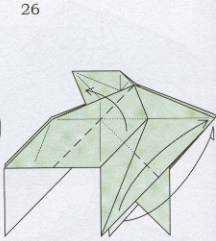

Fold a corner up to the right and a layer up to the left; repeat behind.

27

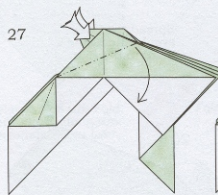

Spread-sink a corner symmetrically. Repeat behind.

28

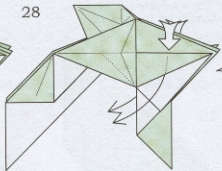

Reverse-fold two flaps down.

29

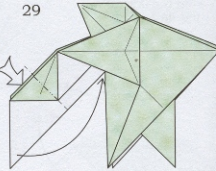

Reverse-fold the flap inside.

30

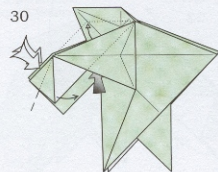

Push up some paper and swivel a layer at the tail. Repeat behind.

31

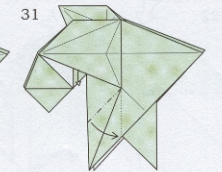

Pull out some loose paper. Repeat behind.

32

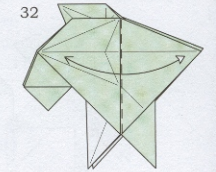

Fold and unfold. Repeat behind.

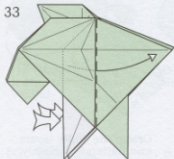

Reverse-fold (closed-sinking at the top). Repeat behind.

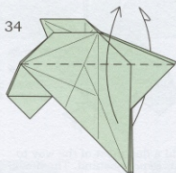

Fold a flap up in front and behind.

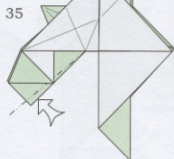

Closed-sink the long edge. Look at the next steps for details.

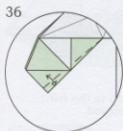

Fold and unfold.

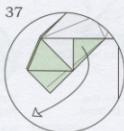

Unfold the colored flap.

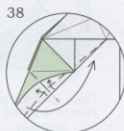

Fold the edge over on the existing crease and re-fold to step 37.

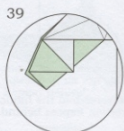

Like this.

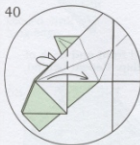

Fold a flap to the right. Repeat behind.

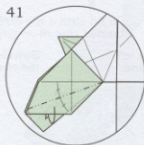

Fold the edge underneath. The fold bisects the angle shown. Repeat behind.

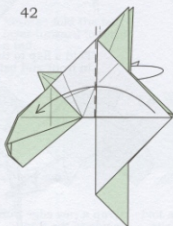

Fold a layer to the left. Repeat behind.

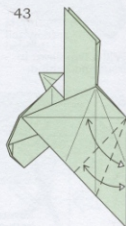

Fold and unfold.

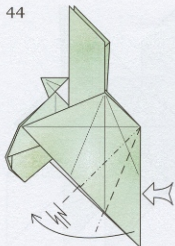

Crimp.

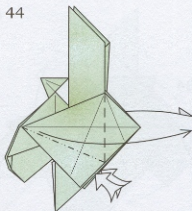

Petal-fold a flap most of the way to the right. Repeat behind. The model will not lie flat.

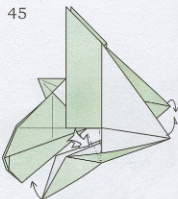

Crimp the white layers and flatten completely.

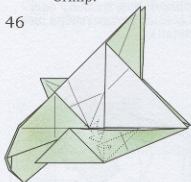

Reverse-fold the hidden corner. Repeat behind.

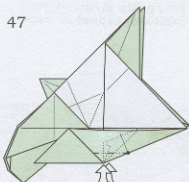

Open-sink the corner (note the reference point). Repeat behind.

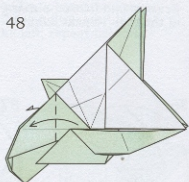

Fold a flap to the left. Repeat behind.

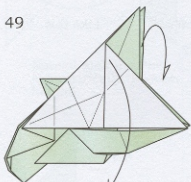

Fold a flap down in front and behind.

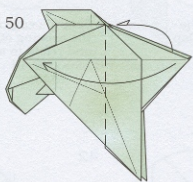

Fold a flap to the left in front and behind.

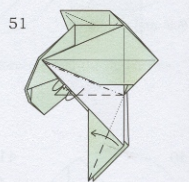

Swivel-fold front and back of the near flap. Repeat behind.

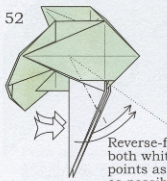

Reverse-fold both white points as far as possible.

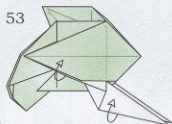

Wrap a raw edge from inside to the front, changing the direction of two creases.

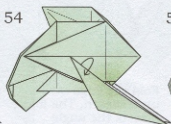

Bring a layer to the front.

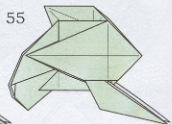

Repeat on the far side of this flap and on both sides of the far flap.

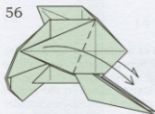

56 Fold the flap down to the right. Repeat behind.



57 Double swivel-fold. Repeat behind.

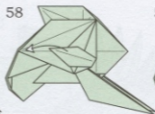

58 Unfold. Repeat behind.



59 Refold, changing the direction of the creases on the near layers. Repeat behind.

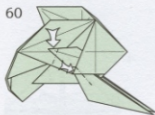

60 Reverse-fold two corners. Repeat behind.

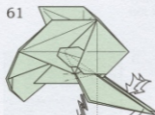

61 Crimp the two flaps to be vertical. The crimps are asymmetric.

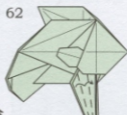

62 Fold a near layer over and over in thirds. Repeat behind.



63 Fold the next layer in thirds and tuck inside, forming a tiny squash at its top end. Repeat behind.

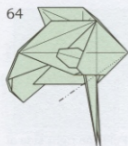

64 Closed-sink the long edge.

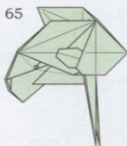

65 Pull out a little bit of paper. Repeat behind.

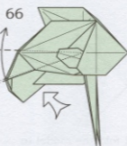

66 Reverse-fold the far layer upward to form a tail.

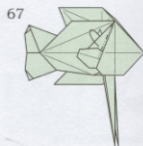

67 Mountain-fold the flap behind. Repeat behind.

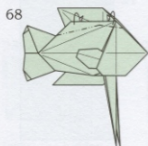

68 Mountain-fold the edges behind. Repeat behind.

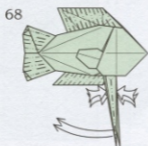

68 Pinch and curve the rays. Plect the fins.

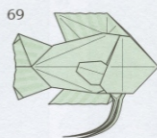

69 Gourami

Lionfish

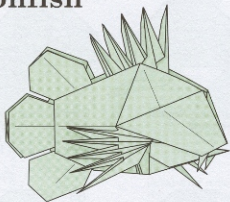

There are several species of lionfish (genus *Pterois*); they belong to the family Scorpionidae, which also includes the stonefish and scorpionfish. The lionfish lives in deep water but close to shore in the region along the Atlantic shore, where it ambushes smaller fish from its rocky hiding places. The lionfish is distinctively colored with red and white stripes, making it highly visible on the reefs where it makes its home. However, its long dorsal spines are tipped with a powerful toxin, making it as deadly as it is beautiful.

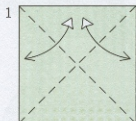

1 Crease the diagonals of the square.

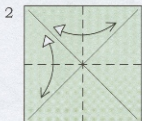

2 Crease it vertically and horizontally.

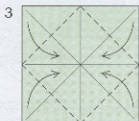

3 Fold the four corners to the center.

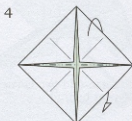

4 Mountain-fold the square in half.

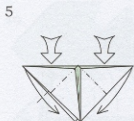

5 Reverse-fold the corners down to make a Preliminary Fold.



6 Petal-fold the model to make a Bird Base.

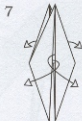

7 Unfold the paper completely.

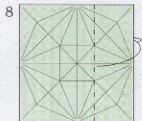

8 Fold the right side of the model behind.

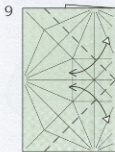

9 Fold and unfold.

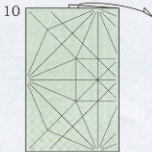

10 Unfold.

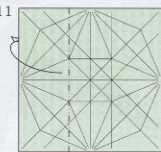

11 Fold the left side behind.

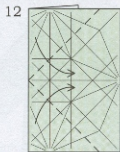

12 Fold like step 9, but don't unfold.

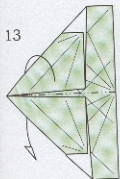

13

Fold the paper in half.

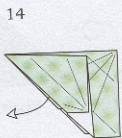

14

Pull out the loose paper.

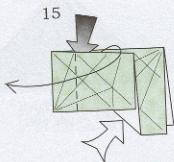

15

Fold a double layer of paper over on the vertical valley fold (the model will not lie flat).

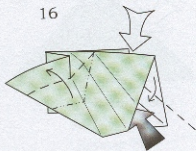

16

Squash-fold this corner down.

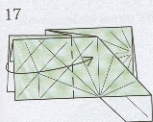

17

Fold the left flap back to the right.

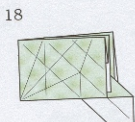

18

Turn the paper over.

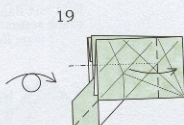

19

Repeat steps 15-16 on this side.



20

Fold and unfold.



21

Fold and unfold.

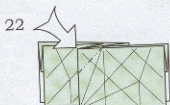

22

Open-sink the corner.

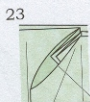

23

Close-up view of the sink.

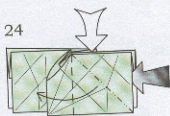

24

Squash-fold the right flap, letting the extra interior layers of paper lie on the right.

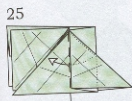

25

Invert the hidden corner, as if making a closed sink.

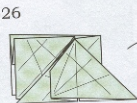

26

Like this. Turn the paper over.

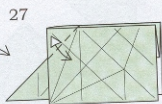

27

Repeat steps 21-25.

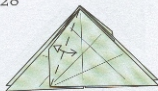

28

Fold and unfold.

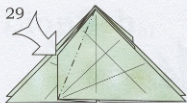

Open-sink the corner.

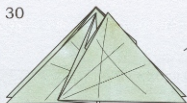

Like this. Turn the paper over.



Repeat steps 28–29.

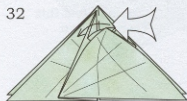

Reverse-fold a double layer of paper to the left.



Fold one flap to the right.

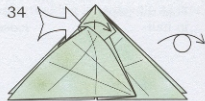

Repeat step 32 here and turn the paper over.

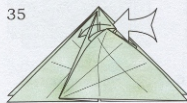

Repeat steps 32–34 on this side.

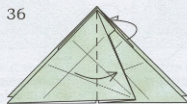

Fold one layer over to the right in front and one to the left in back.

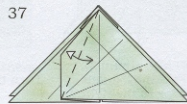

Repeat steps 28–29 here and behind.

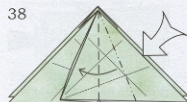

Squash-fold.

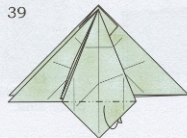

Mountain-fold the flap inside.

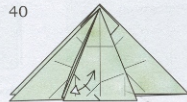

Fold and unfold.

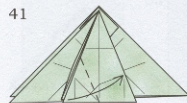

Fold this corner up to the right.

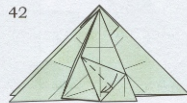

Fold it back down to the bottom.

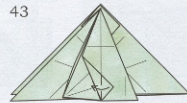

Fold the corner over to the side.

44



Unfold to step 40.

45

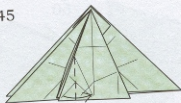

Fold the corner
in to the center.

46

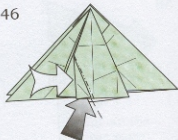

Reverse-fold.

47



Reverse-fold both hidden
corners back out.

48



Reverse-fold
all layers.

49



Repeat steps 40-48
on the right.

50



Fold all of the short flaps to
the right in front and all of
the long flaps to the left in
back. Then rotate 1/4 turn
counterclockwise.

51

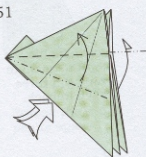

Squash-fold.
Repeat behind.

52

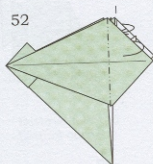

Fold into the
interior.

53

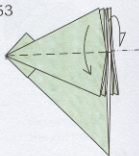

Fold one flap down
on each side.

54

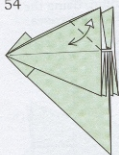

Fold and unfold. In
this and succeeding
drawings, fewer flaps
are shown than are
actually present.

55

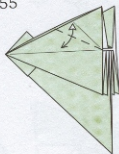

Fold and unfold.

56

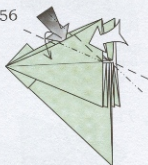

Spread the
upper layers...

57

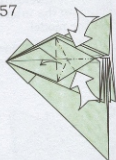

...and push as
much paper to the
left (from the inside)
as possible. Flatten
the paper.

58

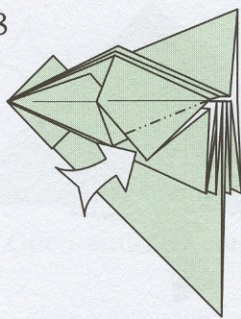

Reverse-fold.

59

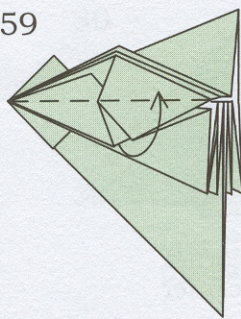

Fold the layers upward. Repeat behind.

60

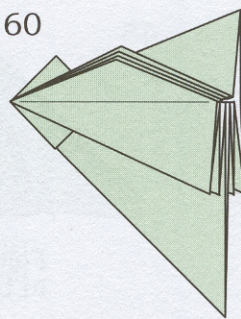

Repeat steps 54-59 behind.

61

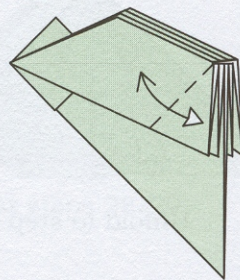

Fold and unfold.

62

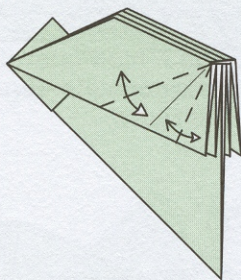

Fold and unfold.

63

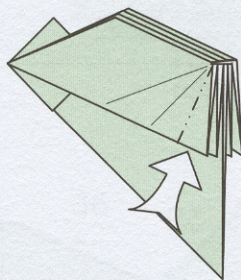

Reverse-fold. Repeat behind.

64

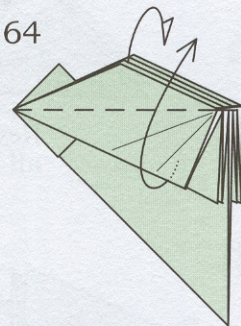

Fold all of the short flaps up in front and three down in back.

65

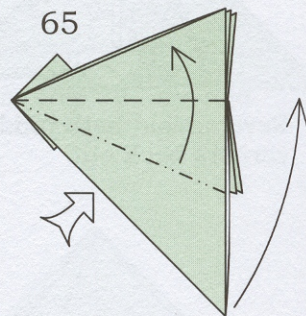

Squash-fold the remaining large flap.

66

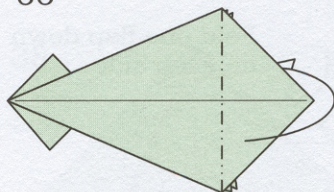

Mountain-fold the tip into the interior of the model.

67

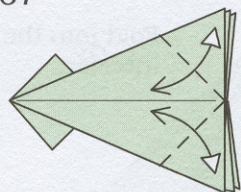

Fold and unfold.

68

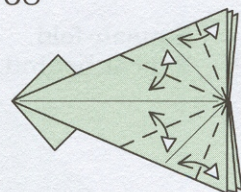

Fold and unfold.

69

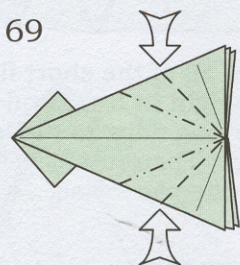

Crimp, using the existing creases.

70

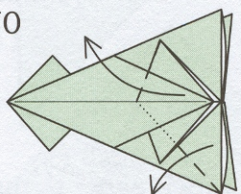

Fold the right point upward, opening out the model.

71

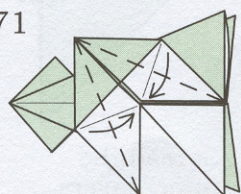

Fold the edges in to the diagonal.

72

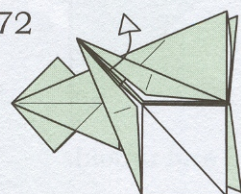

Pull out some loose paper.

73

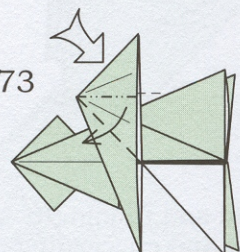

Squash-fold.

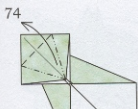

74
Enlarged view.
Petal-fold.



75
Fold the corner
back down.

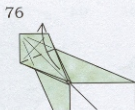

76
Fold the tip up
to the right.

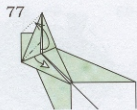

77
Pull out the
loose paper.



78
Squash-fold.



79
Open the flap out.

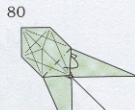

80
Mountain-fold
underneath.

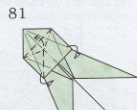

81
Re-form, using the
existing creases.

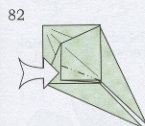

82
Enlarged view.
Reverse-fold
the corner.

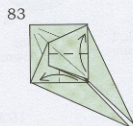

83
Spread the two
points apart.

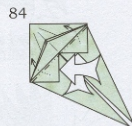

84
Reverse-fold the
bottom corners.

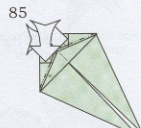

85
Reverse-fold
the corners.

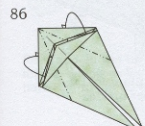

86
Mountain-fold the
blunt corners behind.



87
Fold the top corner
down and close it up.

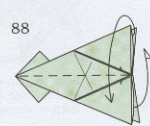

88
Fold one large flap
down in front and
one up in back.

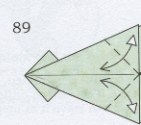

89
Repeat steps 40-49
here and on the back.

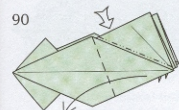

90
Squash-fold.

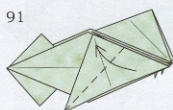

91
Fold a single
point upward.

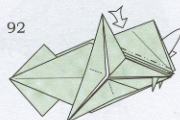

92
Repeat steps 90-91
on the back.

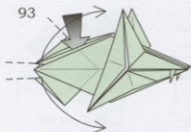

93 Reverse-fold two points at the left upward and downward, respectively.

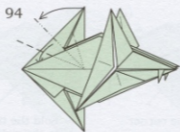

94 Pleat the upper point.

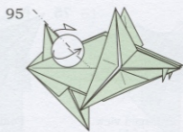

95 Fold all the layers on the front of the point to the right; repeat behind.



96 Squash-fold the hidden corner.



97 Enlarged view. Petal-fold.

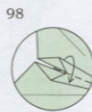

98 Fold one flap down.



99 Closed-sink the point...



100 ...so that it is hidden, like this. If this is too difficult, you can leave it at step 98.

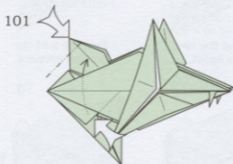

101 Sink the tip of the point and reverse-fold the bottom corner up.

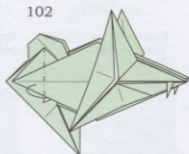

102 Mountain-fold the corner inside.

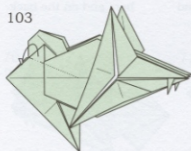

103 Mountain-fold the corner behind.

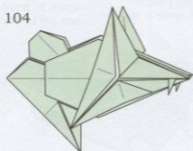

104 Repeat steps 94-103 on the back side of the bottom.

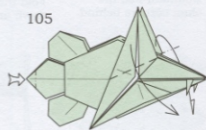

105 Sink the tip of the fin. Fold the flap down in front and back.

106

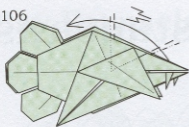

Crimp the thick bundle of points upward toward the tail.

107

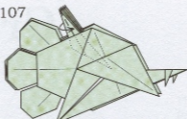

Carefully (because of the thickness) fold the entire bundle of points in half.

108

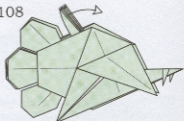

Gently spread the points apart and press the sides so that they hold their shape.

109

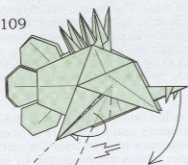

Crimp the left point downward.

110

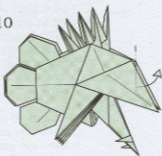

Pull some loose paper out of the far flap.

111

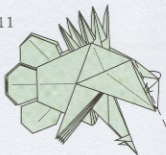

Tuck the far flap into the pocket on the near one.

112

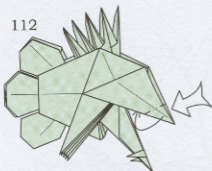

Reverse-fold the tip of the nose inside, which locks the two halves of the head together.

113

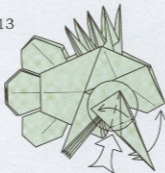

Crimp the lower jaw upward.

114

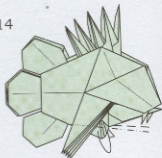

Mountain-fold the thick corners at the belly to the inside of the model (this locks the jaw crimp into place).

115

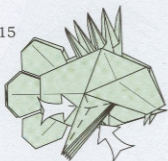

Pinch the pectoral fins in half, forming a rabbit ear through all layers.

116

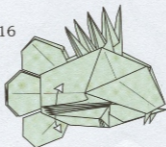

Spread the layers of the pectoral fins apart and pinch them at their base so they stand out away from the body.

117

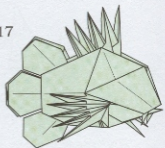

Lionfish

Crustaceans

The crustaceans belong to the much larger group of arthropods. The phylum *Arthropoda* in turn, is the largest single grouping of animals in the world as it contains all the insects. The most well-known crustaceans, the crabs, shrimps, and lobsters, belong to the group known as decapods or ten-legged crustaceans (*deca* means ten and *pod* means leg or foot). They are found in all the waters of the world, fresh as well as salt, and from the poles to the equator.

Almost all crustaceans live underwater. Most of them have two pairs of antennae and some have eyes on movable stalks. Crustaceans have at least five pairs of legs. Their boneless bodies are protected by an outer shell.

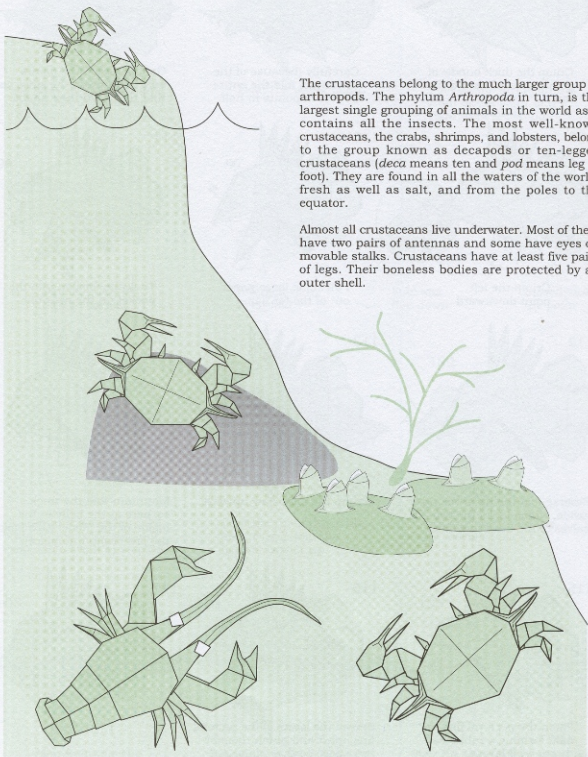

Bay Barnacle

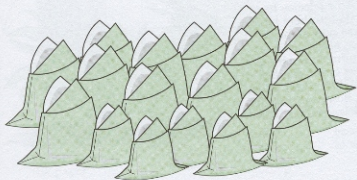

The Bay Barnacle (*Balanus improvisus*) is commonly found attached in great masses to rocks, pilings, oysters, and other hard-shelled animals. Unlike most barnacles, it tolerates fresh water at least occasionally, and is commonly found in bays and brackish estuaries. Barnacles are filter feeders, using their feathery legs to comb the water for plankton and other small organisms.

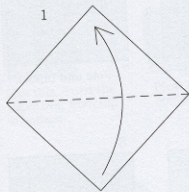

Fold the bottom corner up to the top.

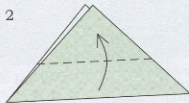

Fold the bottom edge up almost to the top corner (the exact amount isn't critical).

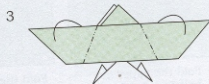

Fold the two corners down so that they cross each other.

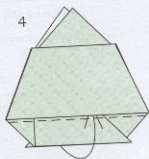

Fold all the layers together as one and tuck inside the model.

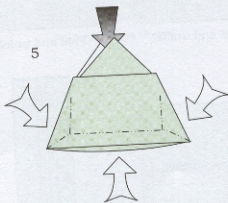

Push in the sides and bottom to make the model three-dimensional.



Bay Barnacle

Blue Crab

The Blue Crab (*Callinectes sapidus*) is a commercially important species that supports a fishing industry in Chesapeake Bay and all along the Atlantic and Gulf coasts. This species has been overexploited through the years, and its numbers have been greatly reduced, but the population has now stabilized due to many fishing restrictions on size, sex, and season for harvest. Some fish farms are even experimenting to see if there is a practical method of culturing them. Blue crabs can get to be 5 or 6 inches across and have a hard shell that is blue above and white below. Immediately after molting, however, the shell is soft and papery, and they are sold (and devoured) as "soft-shell crab."

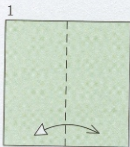
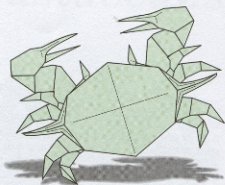

1 Fold the paper in half and unfold.

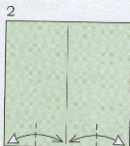

2 Fold the edges to the center, crease, and unfold.

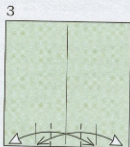

3 Fold and unfold.

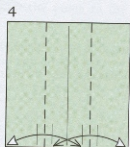

4 Fold and unfold.

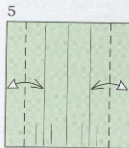

5 Fold and unfold.

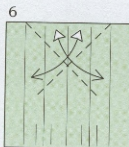

6 Fold and unfold.

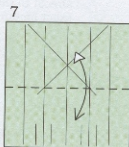

7 Fold and unfold.

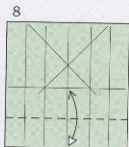

8 Fold and unfold.

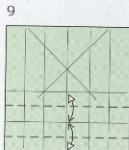

9 Fold and unfold.

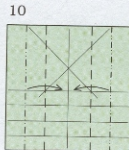

10 Pleat on existing creases.

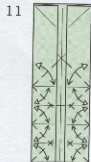

11 Fold and unfold.

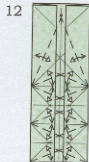

12 Fold and unfold.

13

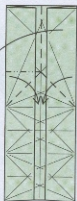

Fold a rabbit ear from the top of the paper.

14

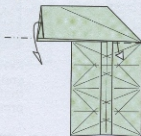

Fold a double layer of paper down from inside the rabbit ear.

15

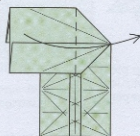

Fold the flap to the right.

16

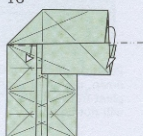

Repeat step 14.

17

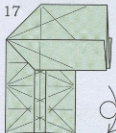

Like this. Turn the paper over from top to bottom.

18

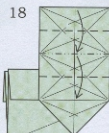

Pleat on existing creases.

19

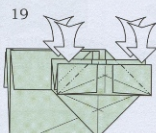

Reverse-fold four corners.

20

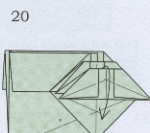

Fold one flap down.

21

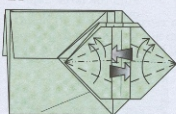

Fold it back up, incorporating the reverse folds shown.

22

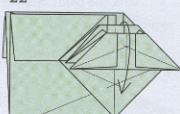

Fold two flaps down.

23

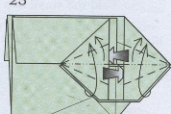

Fold them back up, incorporating the reverse folds shown.

24

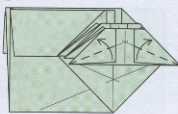

Valley-fold the flaps upward.

25

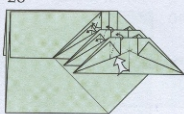

Reverse-fold all the layers on the left side of the pleats.

26

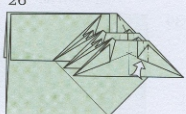

Reverse-fold the layers on the right.

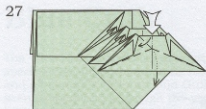

Push the middle of the top pleat down, making the small vertical pleat in the middle. The paper will not lie flat.

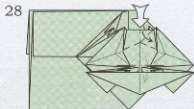

Repeat on the other pleat.

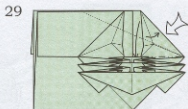

Reverse-fold the right edge and reassemble the creases that came unfolded in the previous step.

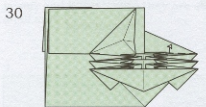

Pull out a single layer of paper from the double thickness rabbit ear to make it symmetric about a horizontal axis.

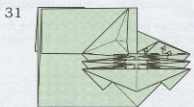

Again, pull out a single layer from the double thickness.

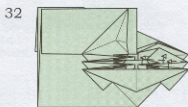

Again.

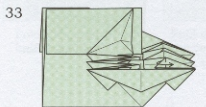

Fold the small flap over to the right.

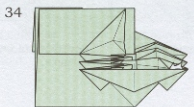

Sink the point into the interior of the model.

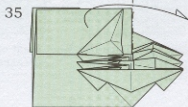

Fold the large flap over to the right.

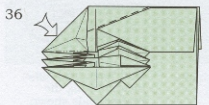

Repeat steps 29-34 on the left.

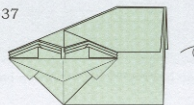

Like this. Turn the paper over.

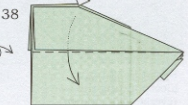

Fold the top flap down while sinking it inside-out.

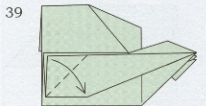

Fold the corner of the flap down.

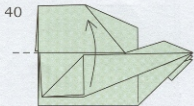

Fold the flap back up.

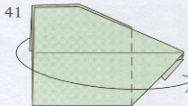

Fold both layers over to the right.

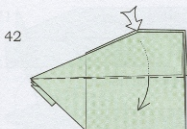

Repeat steps 37-40 on this side.

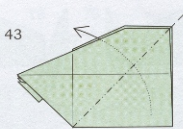

Reverse-fold the corner.

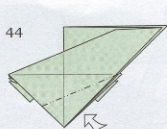

Sink the point.

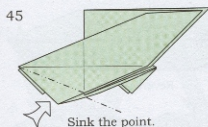

Sink the point.

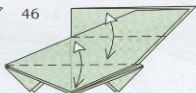

Fold and unfold.

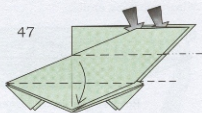

Pleat all layers individually, so that the two flaps remain separated.

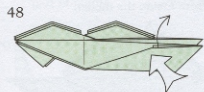

Grasp the original corner of the square that is inside the near flap and pull it entirely out of the flap.



Fold down. The paper will not lie flat.

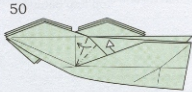

Crimp the paper toward the middle of the model and pull out the paper where shown.

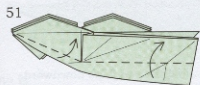

Close the flap back up.

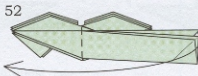

Fold both flaps over to the left.

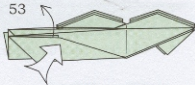

Repeat steps 48-51 on this side.

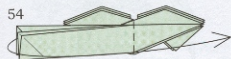

Fold one flap over to the right.

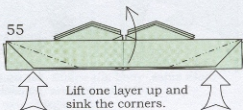

Lift one layer up and sink the corners.



56
Like this. Turn the paper over from side to side.



57
Fold and unfold.



58
Fold and unfold.

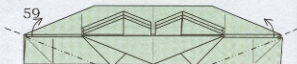

59
Reverse-fold both corners.



60
Reverse-fold both corners.

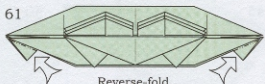

61
Reverse-fold.

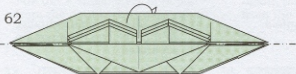

62
Mountain-fold the top flap behind.

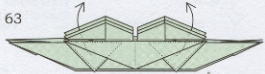

63
Reverse-fold two single-ply flaps up from inside the model.

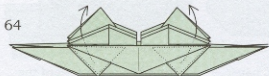

64
Reverse-fold the other two such flaps.

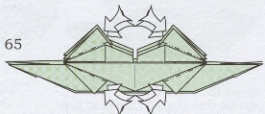

65
Reverse-fold four corners.



66
Like this. Turn the paper over.



67
Mountain-fold the two flaps downward.

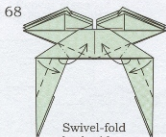

68
Swivel-fold both sides.

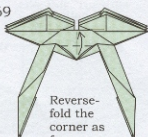

69
Reverse-fold the corner as far up as possible.

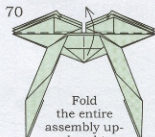

70
Fold the entire assembly upward and turn the paper over from top to bottom.

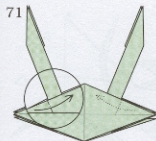

71 Valley-fold the top pair of hidden points to the center line.

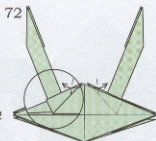

72 Valley-fold the tips of those same points upward.

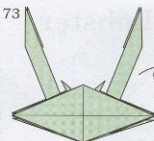

73 Like this. Turn the paper over from side to side.

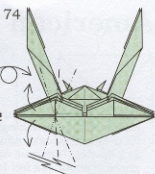

74 Crimp the top pair of points asymmetrically.

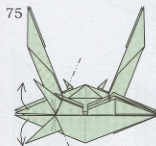

75 Crimp the next pair of points.

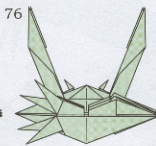

76 Like this. Repeat steps 74-75 on the right.



77 Mountain-fold the layers at the bottom.



78 Crimp all of the legs (only one is shown here).

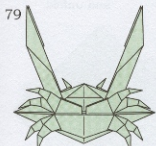

79 Like this. Turn the model over.

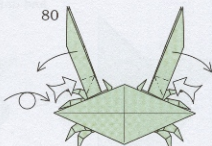

80 Crimp the two long flaps outward.

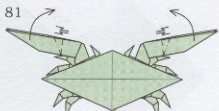

81 Crimp again.

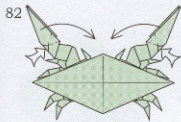

82 Squash-fold the claws toward each other.

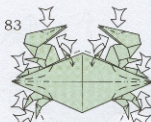

83 Pinch the tips of the claws and the spines on the sides of the shell. Shape the body to be three-dimensional, and squash-fold the bottommost pair of legs.

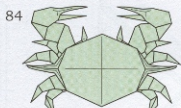

84 Blue Crab

American Lobster

This dark green crustacean has large claws used for crushing and cutting its prey of mollusks and small fish. The lobster (*Homarus americanus*) grows to about two feet long and walks along the ocean floor. It is protected by a hard outer exoskeleton. To grow, it sheds its exoskeleton. While the new one is forming, the lobster hides in holes in the ocean floor.

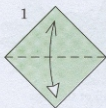
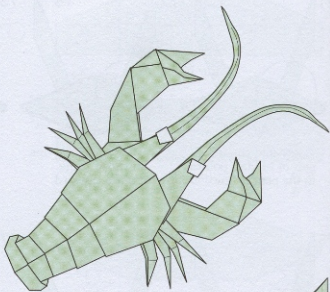

Fold and unfold.

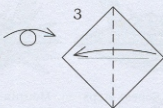
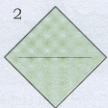

Pinch the top layer in half and unfold.

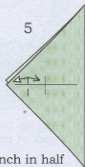

Pinch in half and unfold.

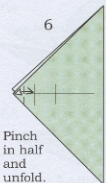

Pinch in half and unfold.

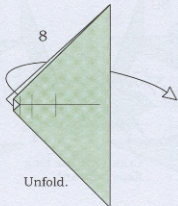
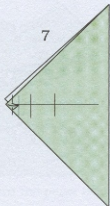

Unfold.

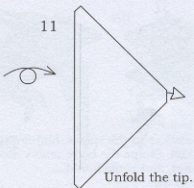
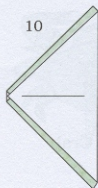
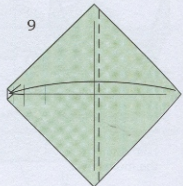

Unfold the tip.

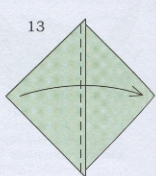
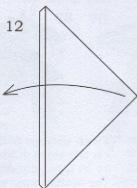

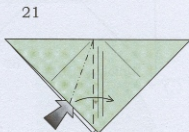
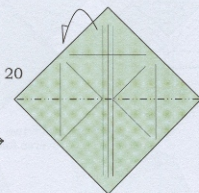
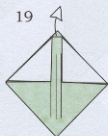
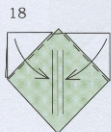
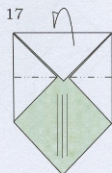
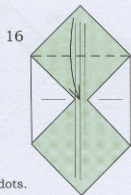
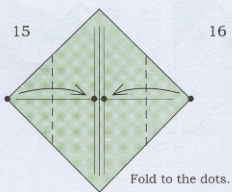
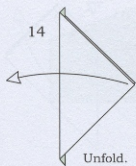

Unfold everything.

Squash-fold.

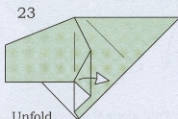
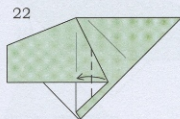

Unfold.

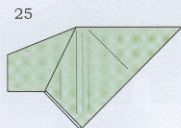
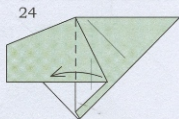

Repeat steps 21-24
on the right.

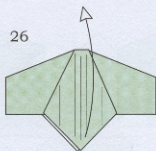

Unfold everything.

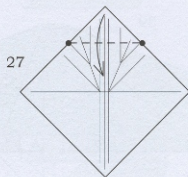

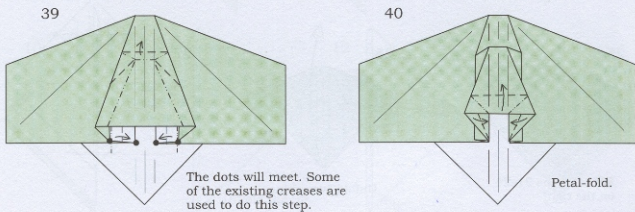
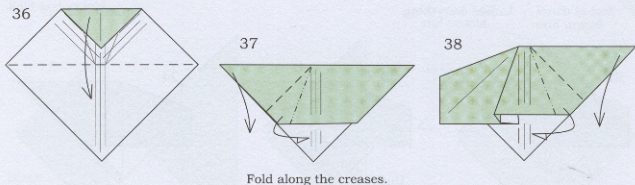
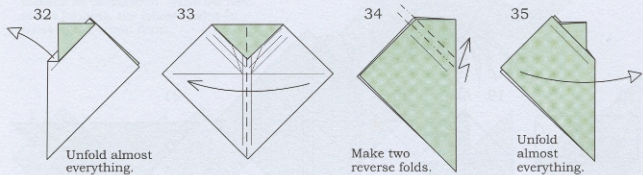
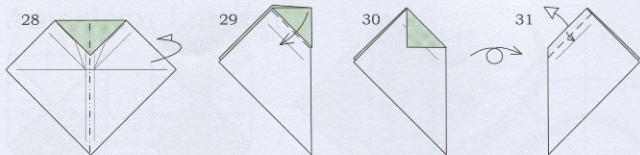

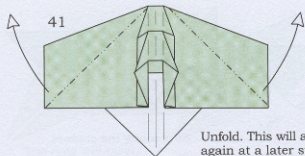

Unfold. This will all be folded again at a later step.

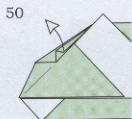
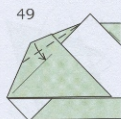
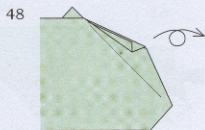
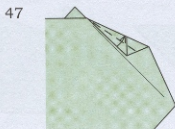
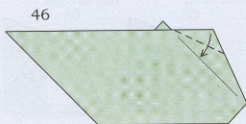
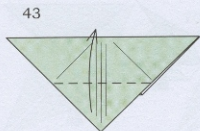
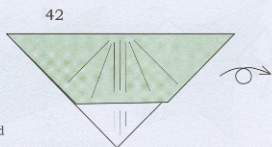

Unfold.

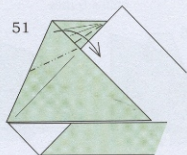

Reverse-fold.

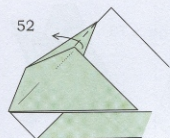

Reverse-fold.

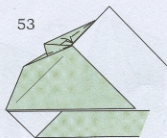

Reverse-fold.

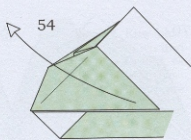

Unfold.

55

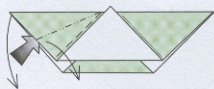

Squash-fold.

56

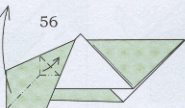

57

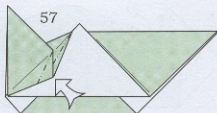

Sink along the creases.

58

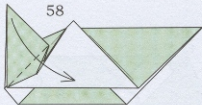

59

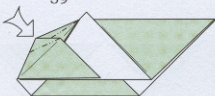

Sink along the creases.

60

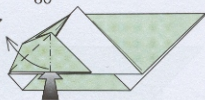

Squash-fold.

61

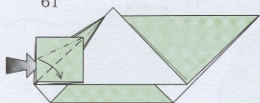

Squash-fold.

62

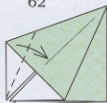
Only part of the
model is drawn.

63



64

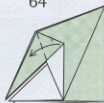

65

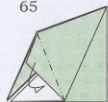

66

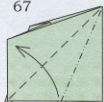

67

Repeat steps 61-66
on the right side.

68

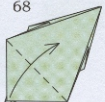

69

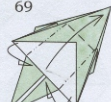

Petal-fold.

70

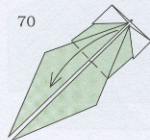

71

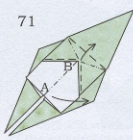

Pinch line A-B first.

72

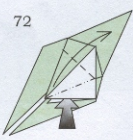

Petal-fold.

73

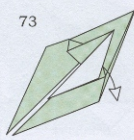

Pull out the white flap.

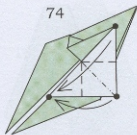

The dots will meet.

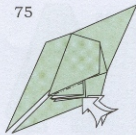

Two reverse folds.

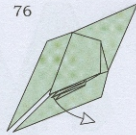

Pull the middle corner all the way out.

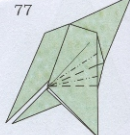

Four reverse folds.

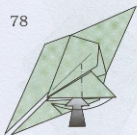

Reverse-fold.

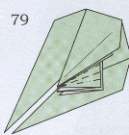

Three reverse folds.

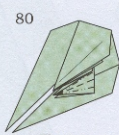

Three more reverse folds.

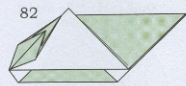
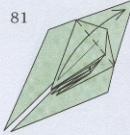

Repeat steps 44-81 on the right side.

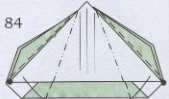
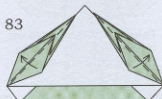

Fold down the corners with the dots.

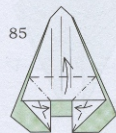

Petal-fold.

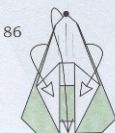

Pull out the white paper and fold the top corner down.



Squash-fold so the dots meet.

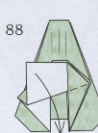

Repeat steps 87-88 on the left side.

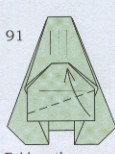
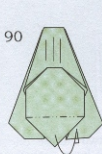

Fold on the crease.

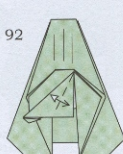

Kite-fold down and unfold. Note that two layers are folded together.

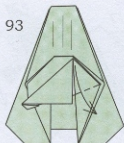

93 Fold back down.



94 Repeat steps 91-93 on the left side.

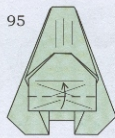

95 Fold up to the horizontal crease.

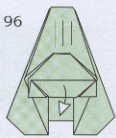

96 Unfold.

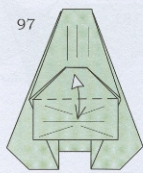

97 Fold down and unfold.

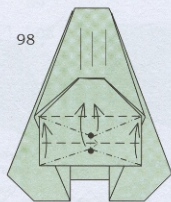

98 Fold the dots up and on top of each other using the existing creases.

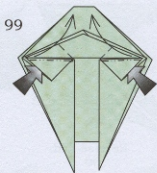

99 Only part of the model is drawn. Make two squash folds.

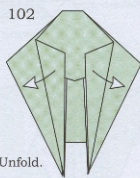
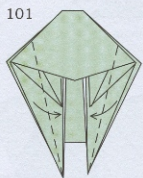
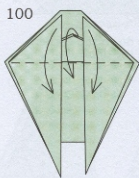

102 Unfold.

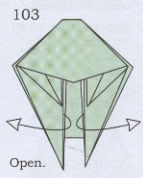

103 Open.

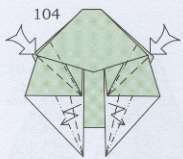

104 Make two reverse folds on each side.

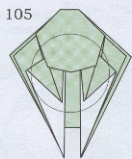

105 The part inside the circle will be enlarged in the next step.

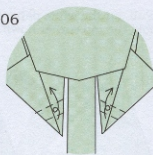

106 Make two simple valley folds to form each eye.

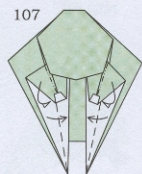

108

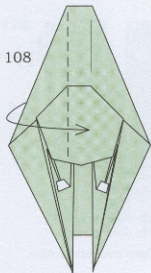

109

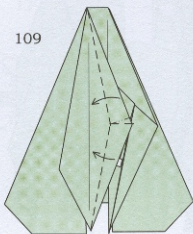

110

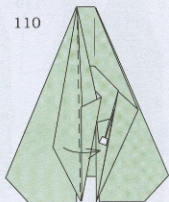

111

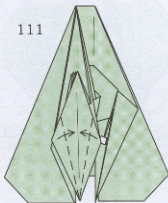

112

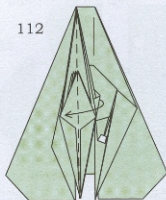

113

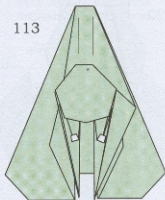

Repeat steps 108-112
on the right side.

114

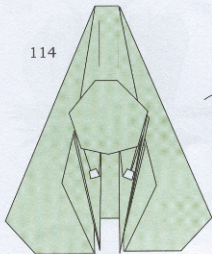

115

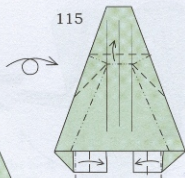

Refold on the creases.

116

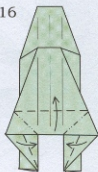

Petal-fold.

117



118

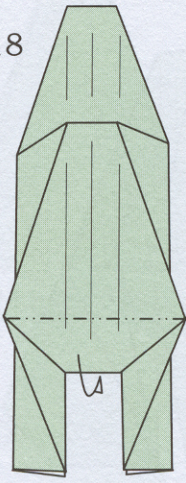

119

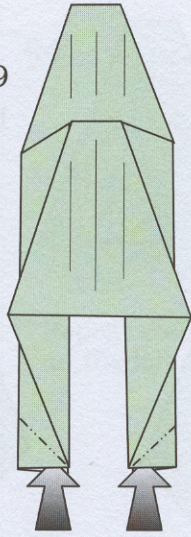

Two reverse folds.

120

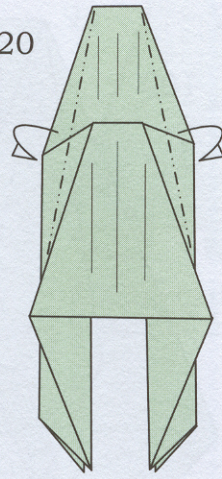

121

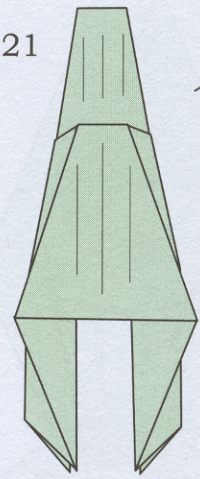

Turn over and rotate.

122

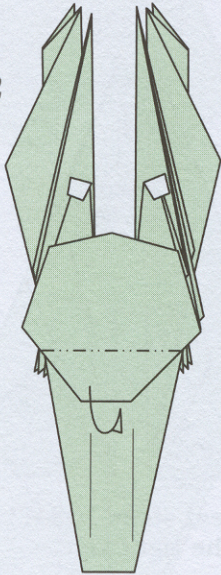

123

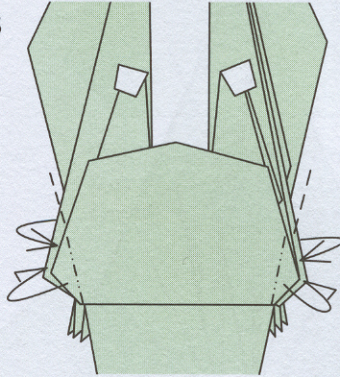

124

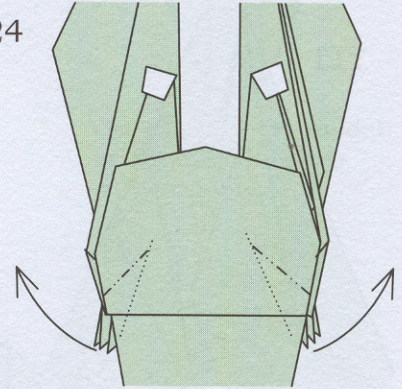

Reverse-fold three corners together on each side.

125

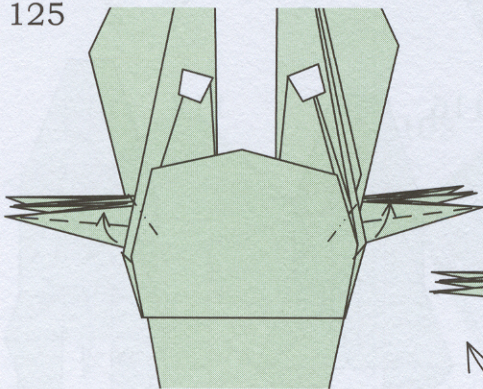

Repeat behind.

126

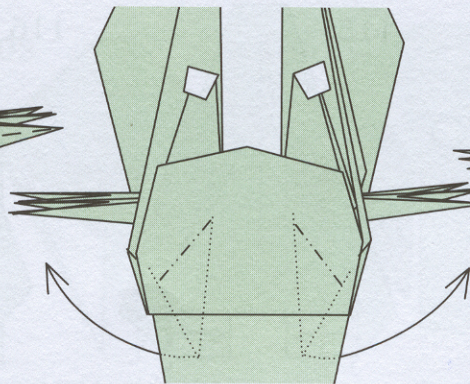

Two reverse folds.

127

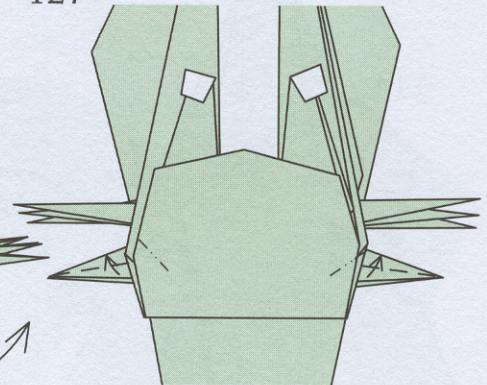

Repeat behind.

128

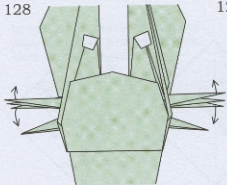

Separate the three legs on each side.

129

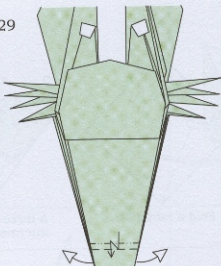

To form the tail, separate as much paper as possible at the bottom. The mountain and valley folds are only for the top layer.

130

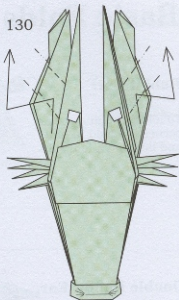

Make two reverse folds on each side to begin the formation of the claws.

131

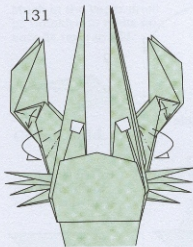

Repeat behind.

132

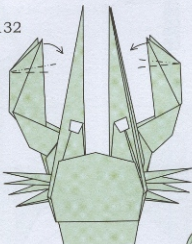

133

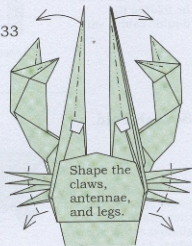

Shape the claws, antennae, and legs.

134

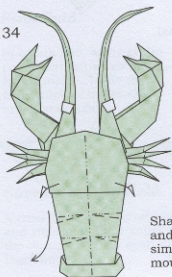

Shape the body and tail with simple valley and mountain folds.

135

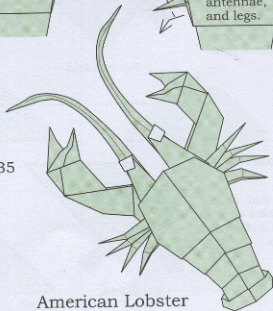

American Lobster