

# BIRDS IN ORIGAMI



John Montroll

# Birds in Origami

John Montroll



Dover Publications, Inc.  
New York

LIBRARY

*To Heidi, Gene and Glenn*

*Copyright*

Copyright © 1995 by John Montroll.  
All rights reserved under Pan American and International Copyright  
Conventions.

Published in Canada by General Publishing Company, Ltd., 30 Lesmill  
Road, Don Mills, Toronto, Ontario.

Published in the United Kingdom by Constable and Company, Ltd., 3 The  
Lanchesters, 162-164 Fulham Palace Road, London W6 9ER.

*Bibliographical Note*

*Birds in Origami* in a new work, first published by Dover Publications, Inc.,  
in 1995.

*Library of Congress Cataloging-in-Publication Data*

Montroll, John.  
*Birds in origami* / John Montroll.  
p. cm.  
ISBN 0-486-28341-0 (pbk.)  
1. Origami. 2. Birds in art. I. Title.  
TT870.M552 1994  
736'.982—dc20

94-40618  
CIP

Manufactured in the United States of America  
Dover Publications, Inc., 31 East 2nd Street, Mineola, N.Y. 11501

# Introduction

This book presents a collection of original origami birds, which you might find in a pond, over the sea, or in a tropical rain forest. You might even find some in your own backyard.

The models are arranged in order of skill level, from the simple-to-fold duck to the high-intermediate parrot.

The diagrams follow the internationally approved Randlett-Yoshizawa style, which is easy to follow once you have learned the basic folds. You can use any kind of square paper for these models, but the best results and most precise folding can be achieved using standard origami paper, which is colored on one side and white on the other. In these diagrams, the shading represents the colored side. Origami paper can be found in many hobby shops or purchased by mail from Origami USA, a nonprofit organization of dedicated paperfolders. For more information about the group, send a self-addressed business-size envelope with two first-class stamps to:

Origami USA  
15 West 77th St.  
New York, NY 10024-5192

Origami paper, and a catalog of other available craft books, can also be ordered from Dover Publications, Inc., at:

Dover Publications, Inc.  
31 East 2nd St.  
Mineola, NY 11501

Enjoy, and Happy Folding.

John Montroll

# Symbols

## Lines



Valley fold, fold in front.



Mountain fold, fold behind.



Crease line.



X-ray or guide line.

## Arrows



Fold in this direction.



Fold behind.



Unfold.



Fold and unfold.



Turn over.



Sink or three dimensional folding.



Place your finger between these layers.

# Basic Folds

## Rabbit Ear.

To fold a rabbit ear, one corner is folded in half and laid down to a side.



Fold a rabbit ear.

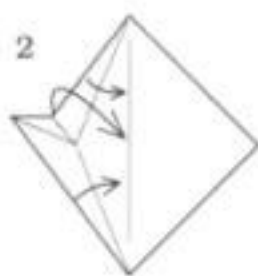

A three-dimensional intermediate step.

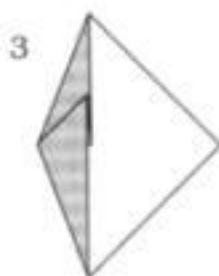

## Double Rabbit Ear.

If you were to bend a straw you would be folding the double rabbit ear.

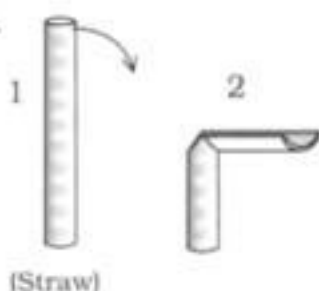

(Straw)

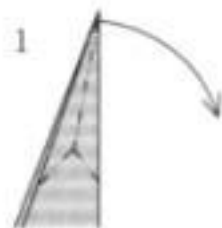

Make a double rabbit ear.

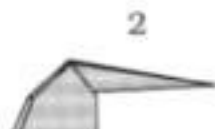

## Squash Fold.

In a squash fold, some paper is opened and then made flat. The shaded arrow shows where to place your finger.



Squash-fold.

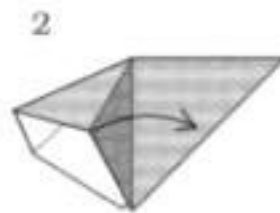

A three-dimensional intermediate step.

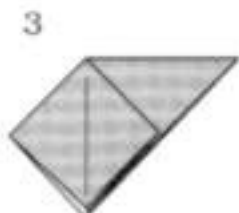

## Petal Fold.

In a petal fold, one point is folded up while two opposite sides meet each other.

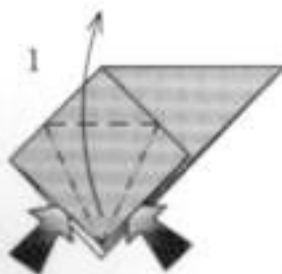

Petal-fold.

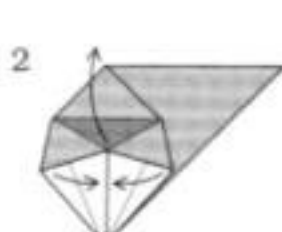

A three-dimensional intermediate step.

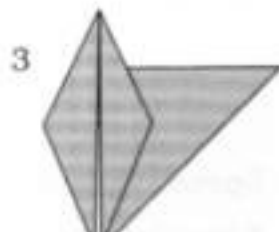

## Inside Reverse Fold.

In an inside reverse fold, some paper is folded between layers. Here are two examples.

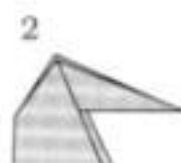

## Outside Reverse Fold.

Much of the paper must be unfolded to make an outside reverse fold.

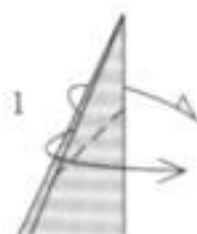

Outside-reverse-fold.

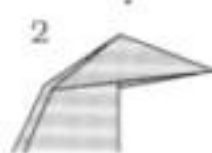

## Crimp Fold.

A crimp fold is a combination of two reverse folds.



Crimp-fold.

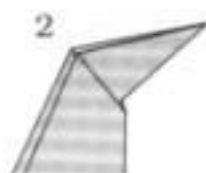

## Sink Fold.

In a sink fold, some of the paper without edges is folded inside. To do this fold, much of the model must be unfolded.

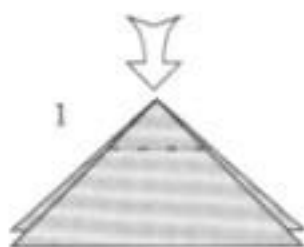

Sink.



## Spread Squash Fold.

A cross between a squash fold and sink fold, some paper in the center is spread apart and then made flat.



Spread-squash-fold.



# Contents



Duck  
Page 9



Swan  
Page 11



Goose  
Page 13



Flamingo  
Page 15



Pelican  
Page 18

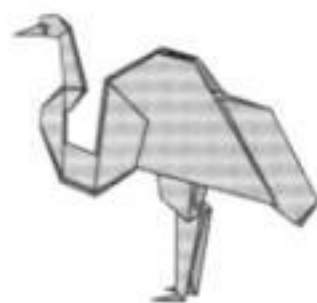

Heron  
Page 20

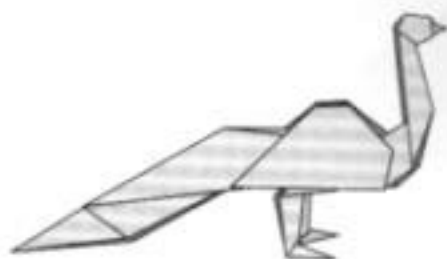

Pheasant  
Page 22

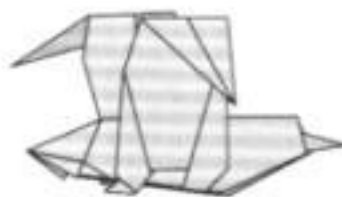

Seagull  
Page 25





Hummingbird  
Page 27



Cardinal  
Page 30



Cormorant  
Page 33



Stork  
Page 36

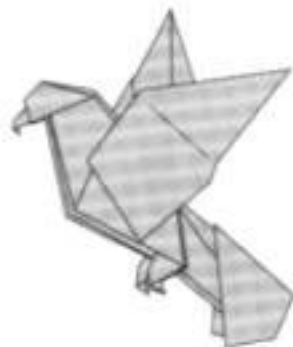

Eagle  
Page 39

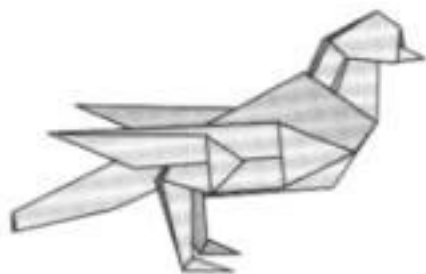

Canary  
Page 42



Parrot  
Page 45

# Duck

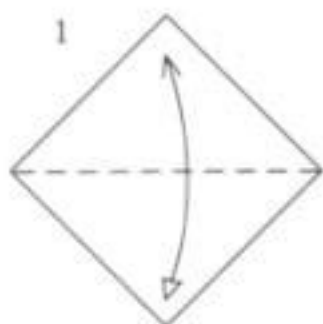
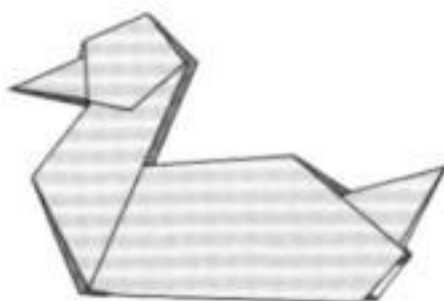

Fold and unfold.

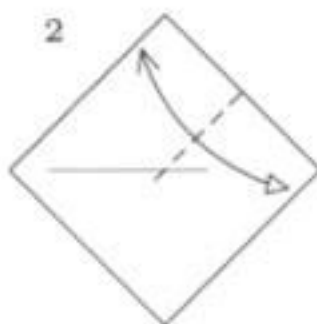

Fold and unfold.

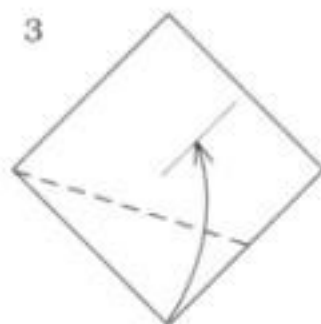

Fold the corner to the center line.

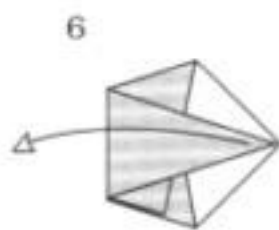
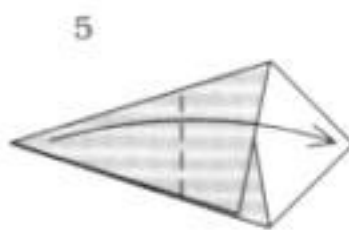
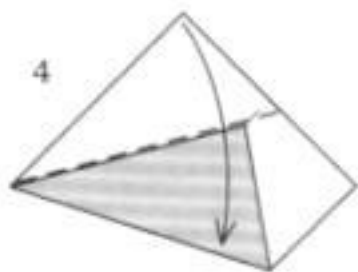

Unfold.

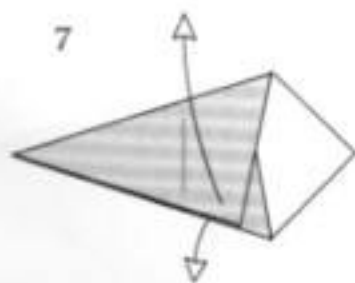

Fold and unfold.

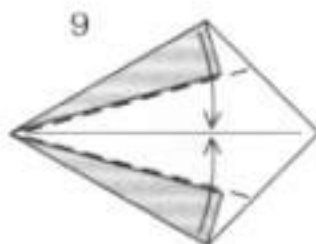
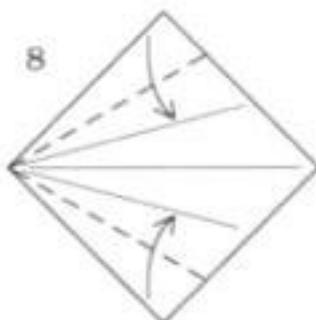

10



Fold to the center line.

11



Pull out from inside.

12



13



Fold down from above the center line and rotate.

14

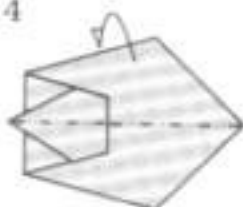

Fold behind.

15

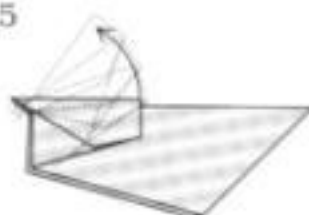

Slide the neck.

16



Slide the head.

17



Fold the tip in and out for the beak.

18



Fold in and out for the tail.

19



Fold a thin layer behind, repeat behind.

20

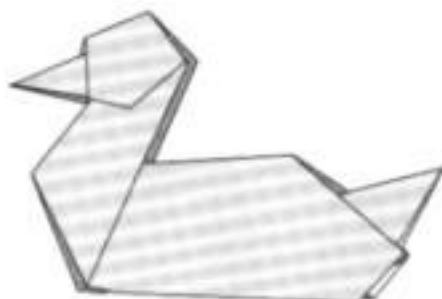

Duck

# Swan

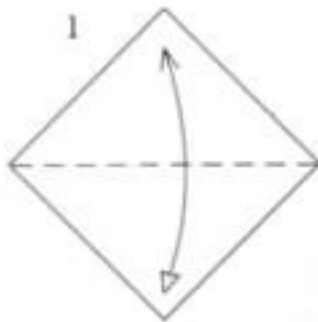
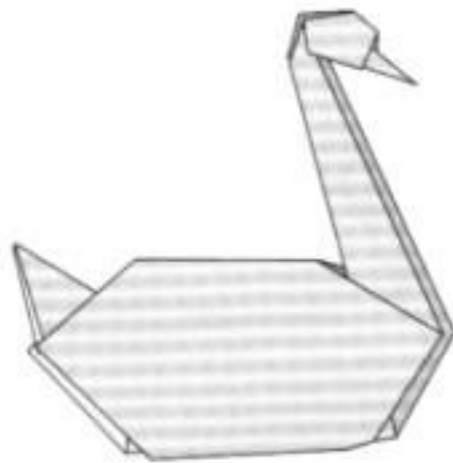

Fold and unfold.

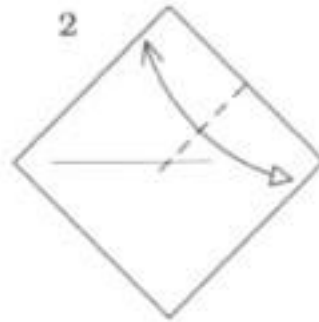

Fold and unfold.

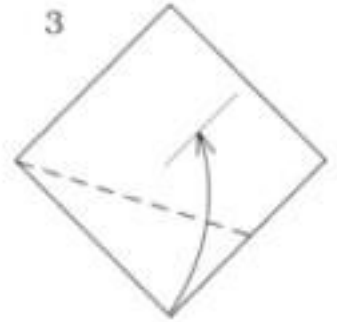

Fold the corner to the center line.

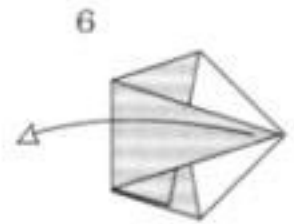
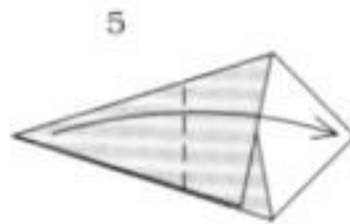
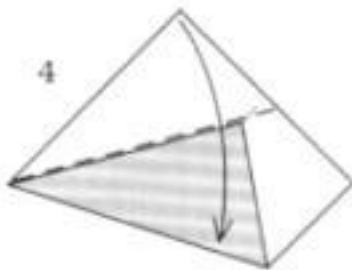

Unfold.

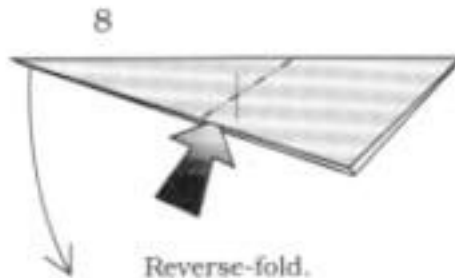
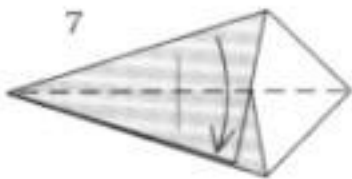

Reverse-fold.

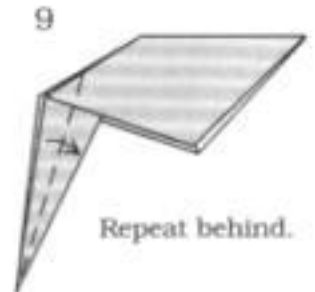

Repeat behind.

10

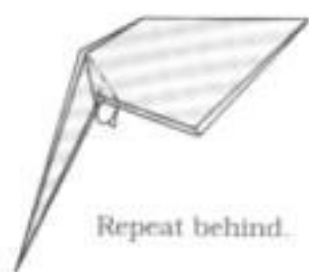

Repeat behind.

11

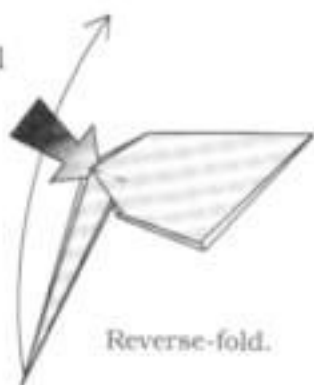

Reverse-fold.

12



Reverse-fold.

13



Spread the head while folding down.

14



Fold the beak in and out.

15



Fold the tail in and out.

16



Fold a thin layer behind, repeat behind.

17

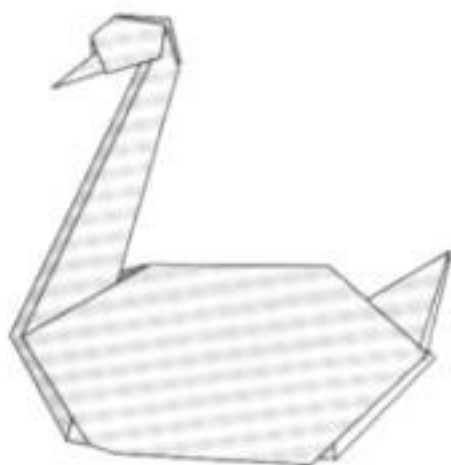

Swan

# Goose

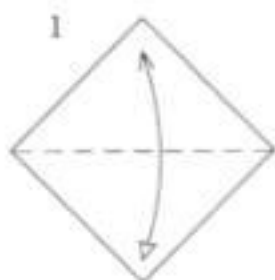
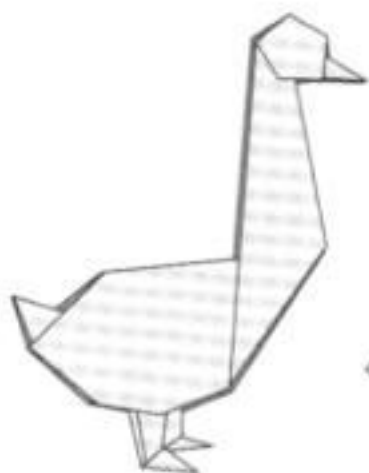

1  
Fold and unfold.

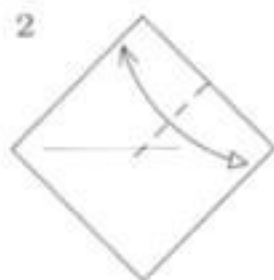

2  
Fold one corner to the other and unfold.

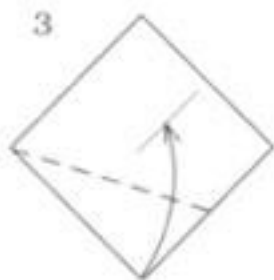

3  
Fold the corner to the center line.

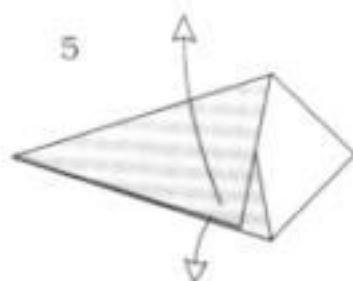
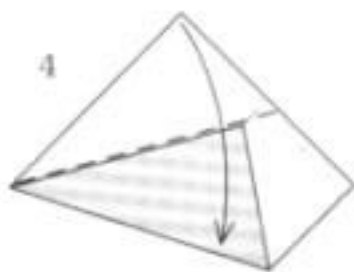

4  
5  
Unfold.

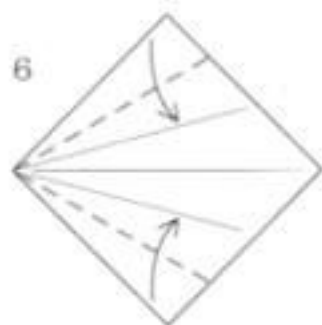

6  
Fold to the creases.

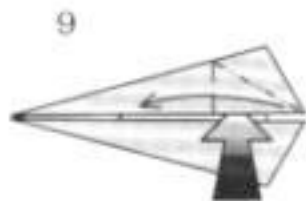
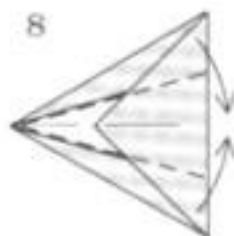
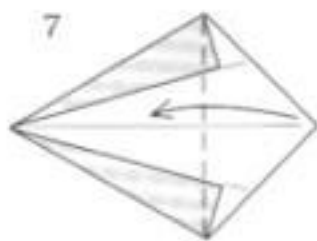

7  
8  
9  
Squash-fold.

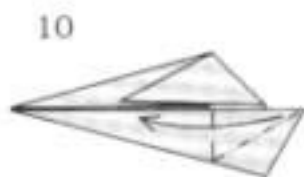

10  
Squash-fold.

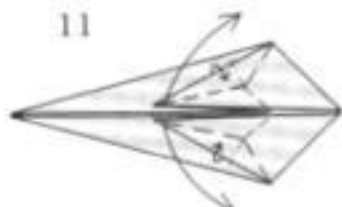

11  
Rabbit ears.

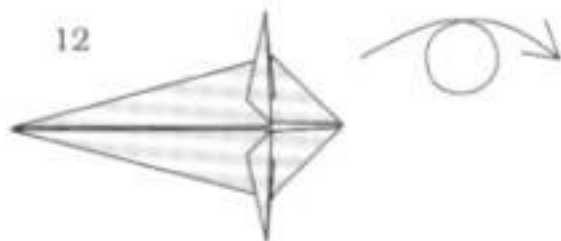

12

13

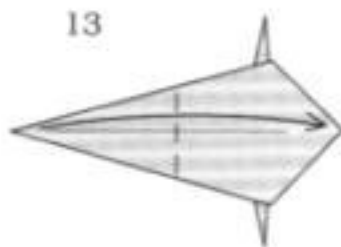

14

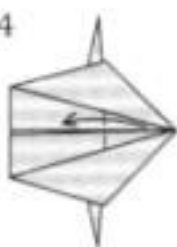

15

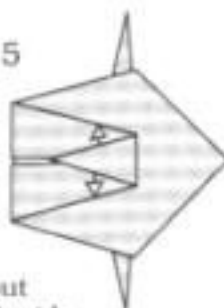

Pull out from inside.

16

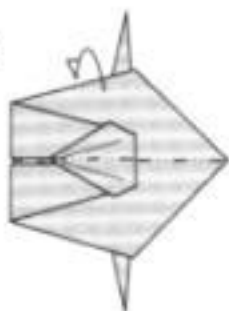

Fold behind.

17



Slide the neck.

18

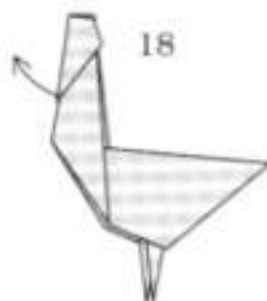

Slide the head.

19

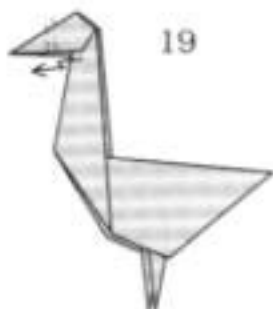

Fold the tip in and out.

20

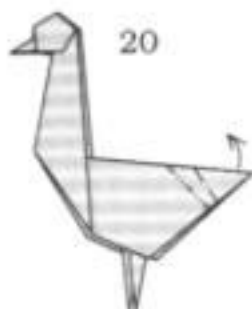

Fold the tail in and out.

21

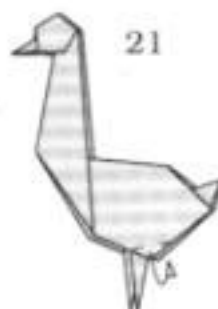

Fold behind, repeat behind.

22

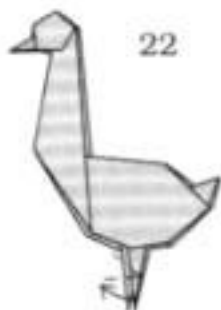

Bend to form the feet.

23

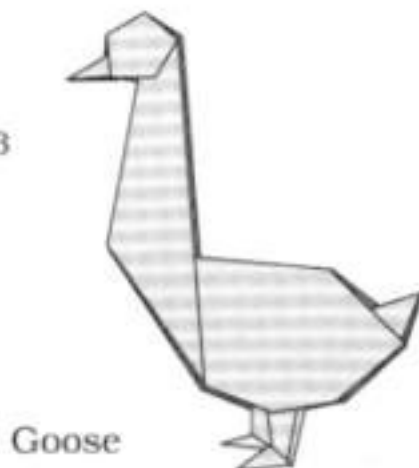

Goose

# Flamingo

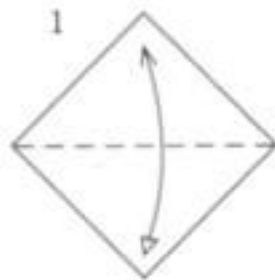
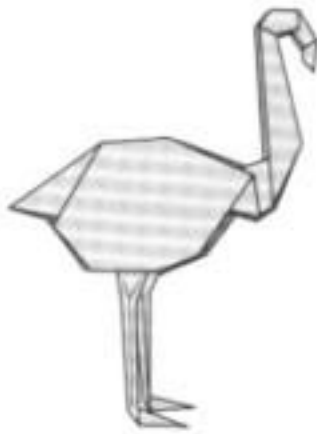

Fold and unfold.

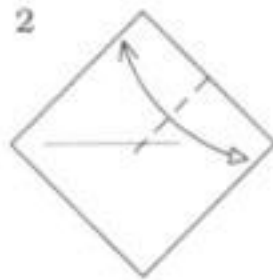

Fold one corner to the other and unfold.

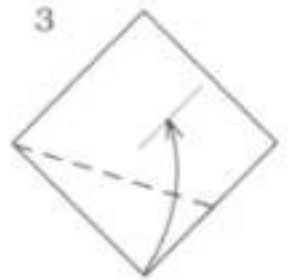

Fold the corner to the center line.

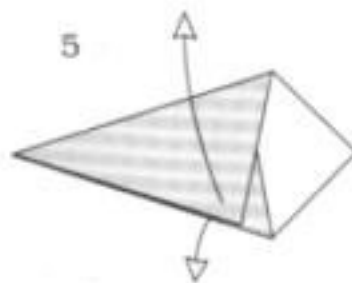
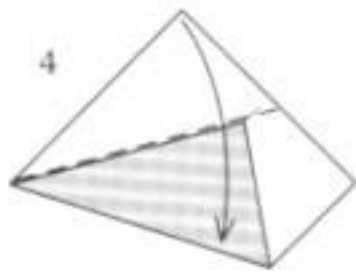

Unfold.

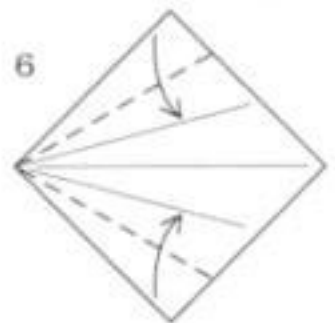

Fold to the creases.

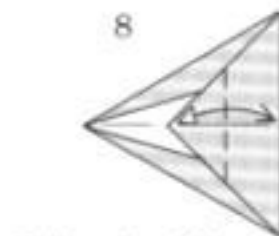
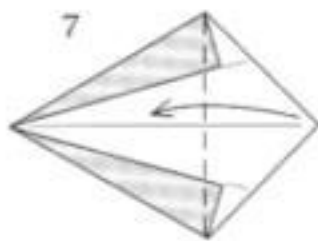

Fold and unfold.

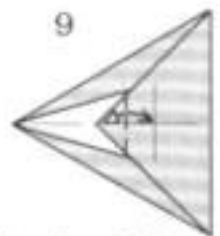

Fold and unfold.

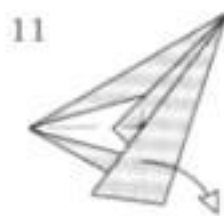
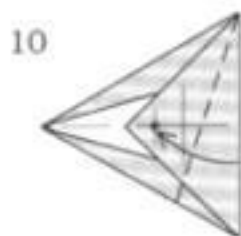

Unfold.

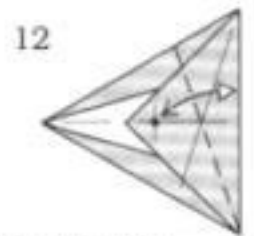

Fold and unfold.



13

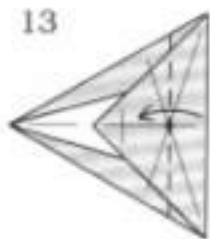

14

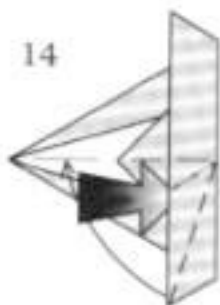

Fold inside.

15



Fold inside.

16

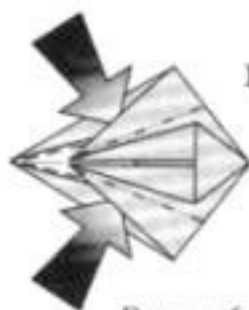

Reverse folds.

17

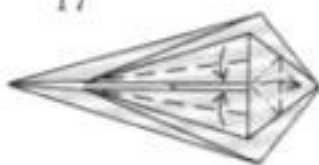

Petal-fold.

18

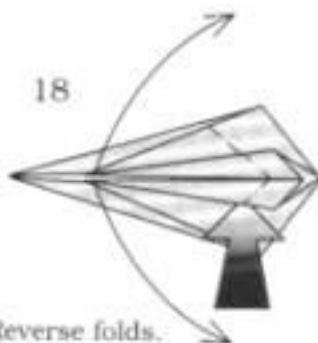

Reverse folds.

19

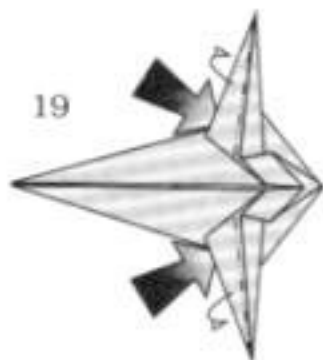

Reverse folds.

20

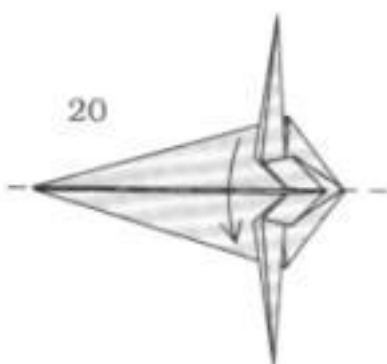

21



Reverse-fold.

22



Repeat behind.

23



Reverse-fold.

24

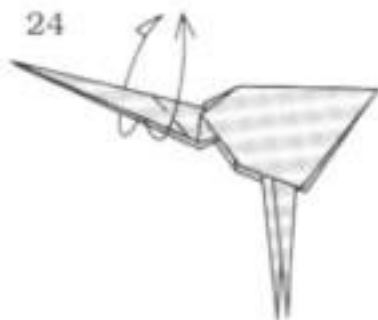

Outside-reverse-fold.

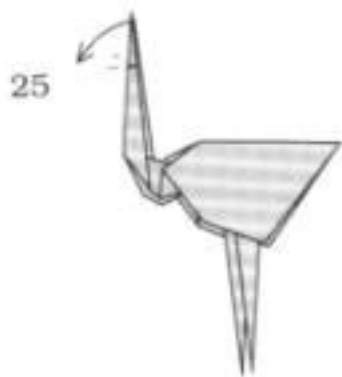

Spread the paper.



Spread the paper while crimp folding.



Crimp-fold.

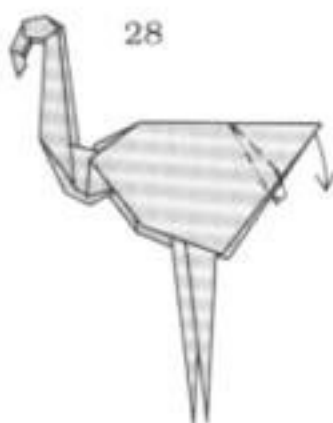

Crimp-fold.

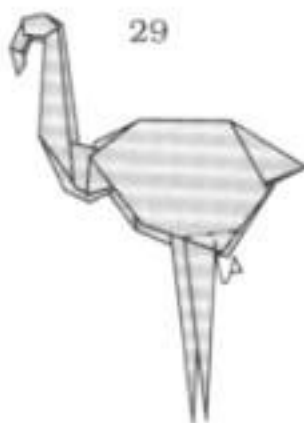

Fold behind, repeat behind.



Reverse-fold, repeat behind.



Squeeze the legs, the flamingo can stand.

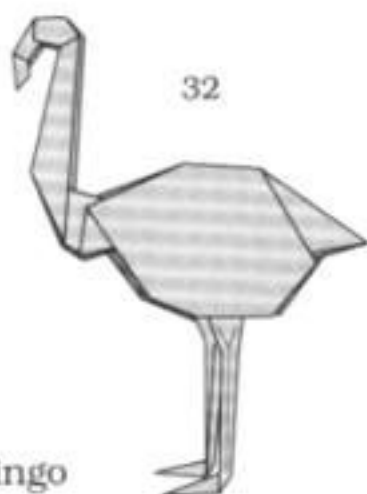

Flamingo

# Pelican

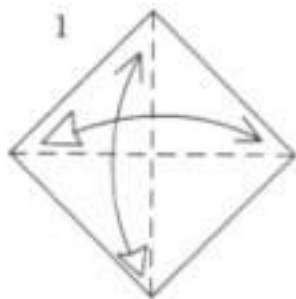
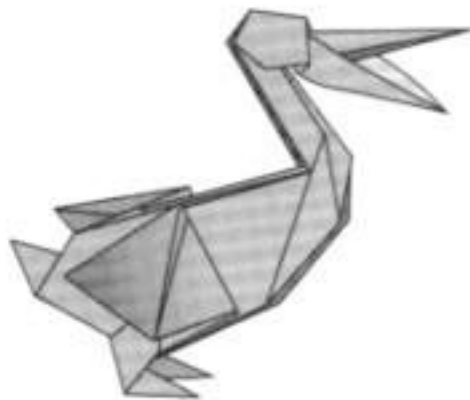

1  
Fold and unfold  
along the diagonals.

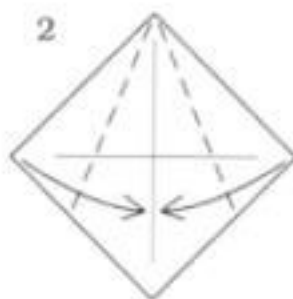

3  
Squash fold.

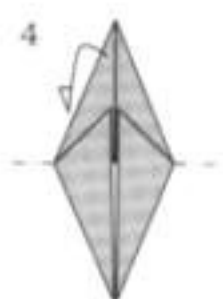

5  
Rotate.

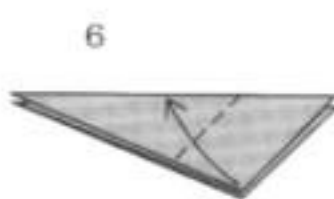

6  
Repeat behind.

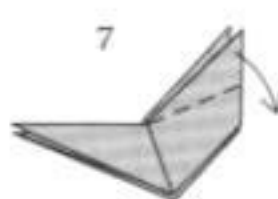

7  
Repeat behind.

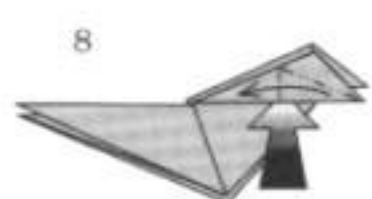

8  
Squash-fold,  
repeat behind.



9  
Repeat behind.

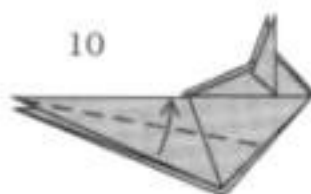

10  
Repeat behind.

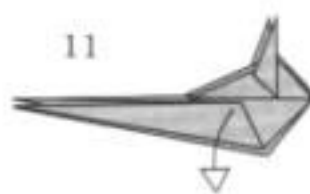

11  
Unfold, repeat behind.



12  
Reverse-fold,  
repeat behind.

13

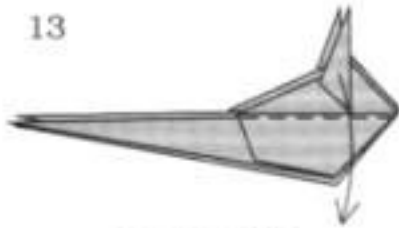

Repeat behind.

14

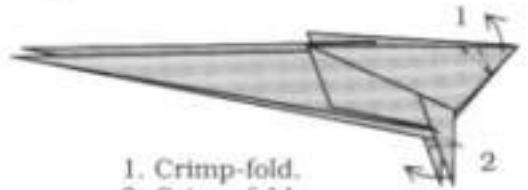

1. Crimp-fold.  
2. Crimp-fold,  
repeat behind.

15

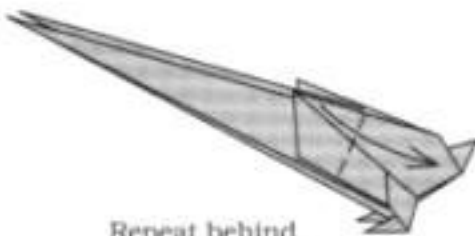

Repeat behind.

16

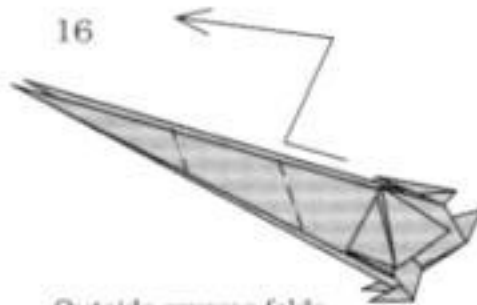

Outside reverse folds.

17

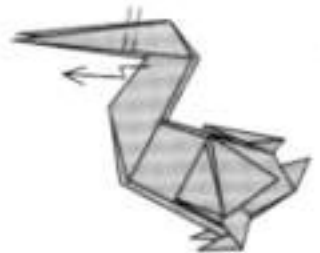

Crimp-fold.

18



Repeat behind.

19



Open the beak.

20

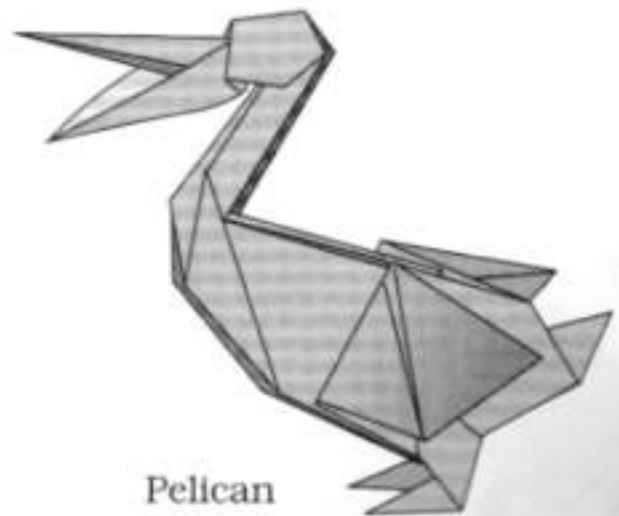

Pelican

# Heron

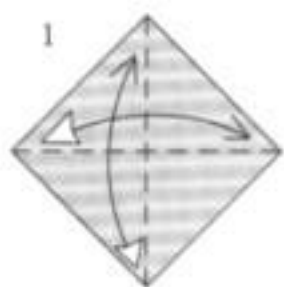
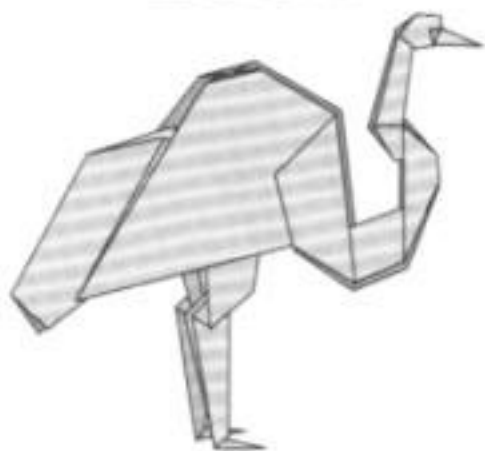

1  
Fold and unfold  
along the diagonals.

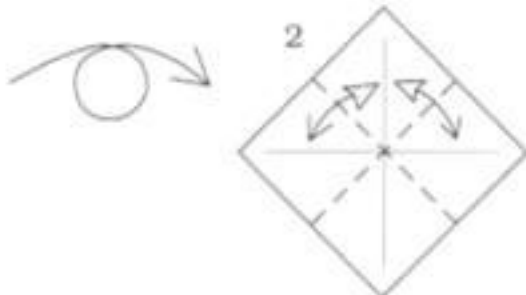

2  
Fold and unfold.

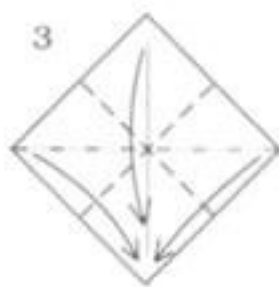

3  
Collapse the square  
by bringing the four  
corners together.

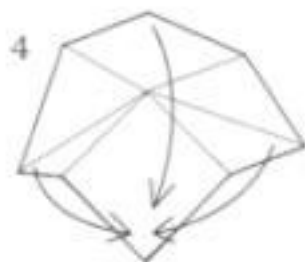

4  
This is a three-  
dimensional  
intermediate step.



5  
Kite-fold, repeat behind.

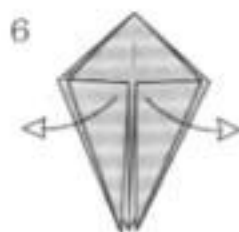

6  
Unfold, repeat behind.



7  
Petal-fold.

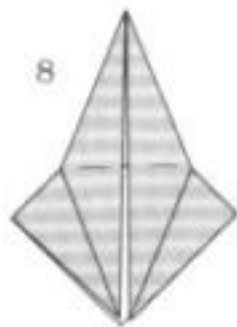

8  
Repeat step 7 behind.

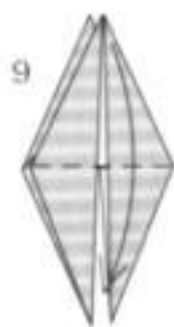

9  
Repeat behind.

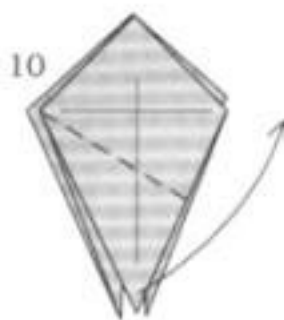

10  
Repeat behind.

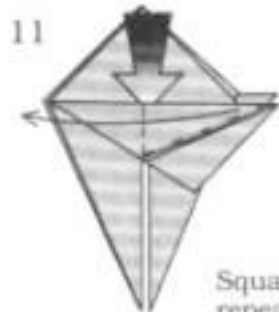

Squash-fold,  
repeat behind.

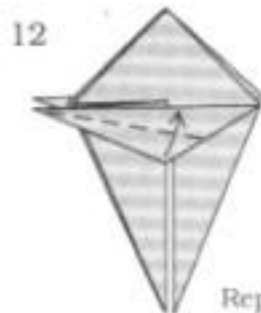

Repeat behind.

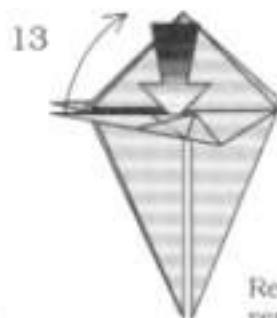

Reverse-fold,  
repeat behind.



Fold inside,  
repeat behind.

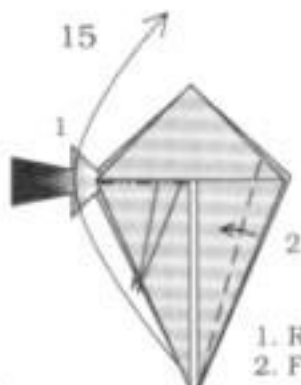

1. Reverse-fold.  
2. Fold at angle of one-third,  
repeat behind.

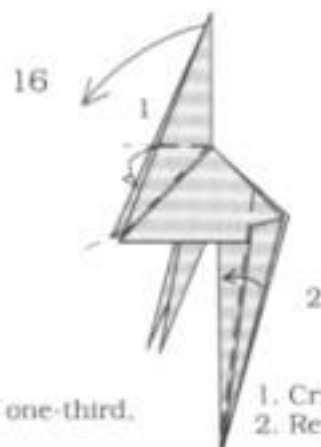

1. Crimp-fold.  
2. Repeat behind.



1. Slide the tail down.  
2. Reverse folds.

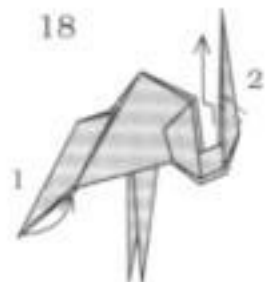

Reverse folds.

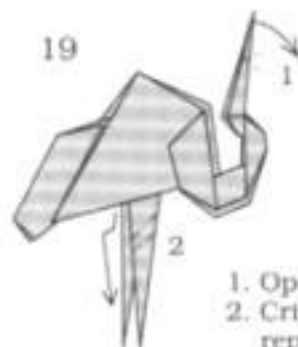

1. Open the head.  
2. Crimp-fold,  
repeat behind.

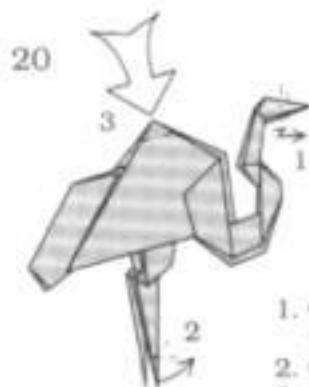

1. Crimp-fold the beak,  
then fold the eyes.  
2. Crimp-fold the feet.  
3. Sink the back.  
Repeat behind.

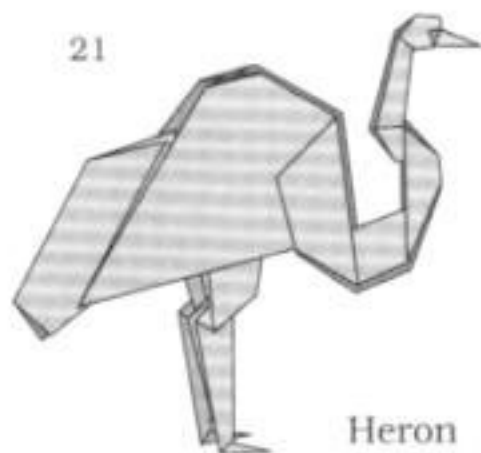

Heron

# Pheasant

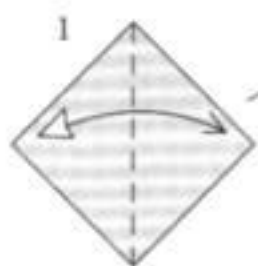
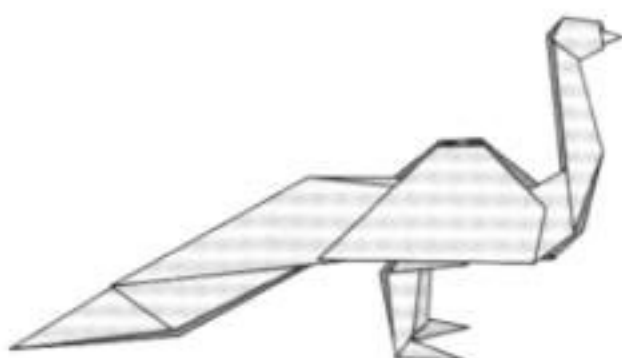

Fold and unfold.

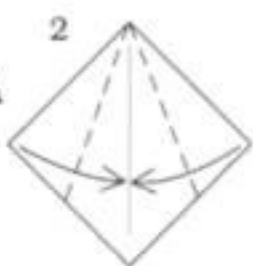

Kite-fold.

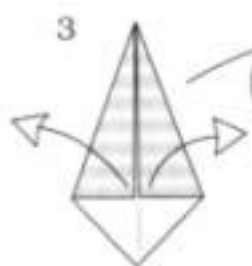

Unfold.

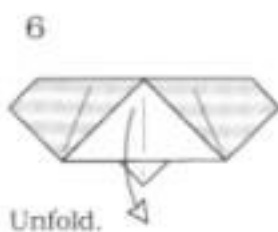
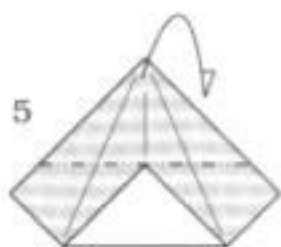
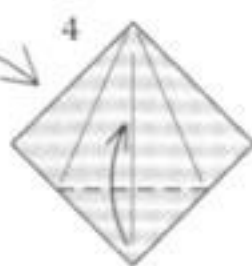

Unfold.

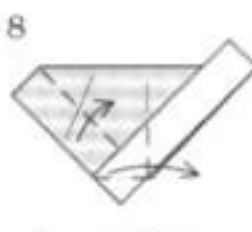
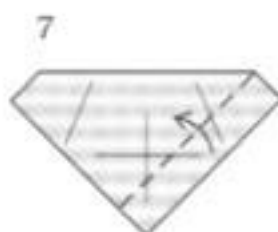

Squash-fold.

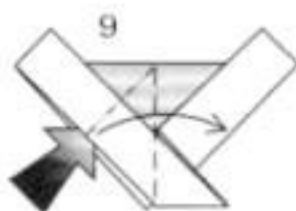

Squash-fold.

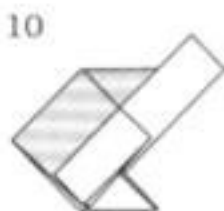

Squash-fold.

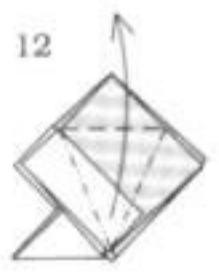

12  
Petal-fold,  
repeat behind.

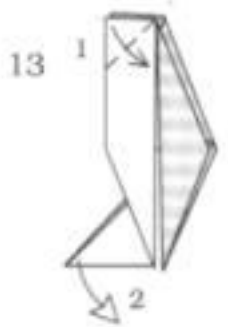

13  
1. Repeat behind.  
2. Pull out.

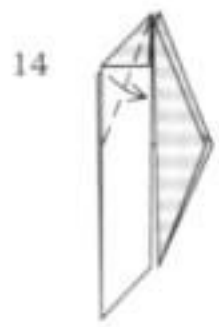

14  
Repeat behind.



15



16



17

Outside-reverse-fold.



18



19

Petal-fold.



20

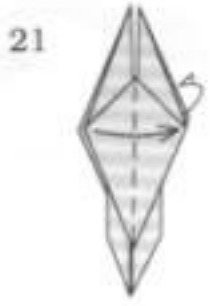

21



22

Repeat behind,



23

Rabbit-ear,  
repeat behind.



24

Repeat behind.



25

Reverse-fold,  
repeat behind.



26

Fold inside,  
repeat behind.

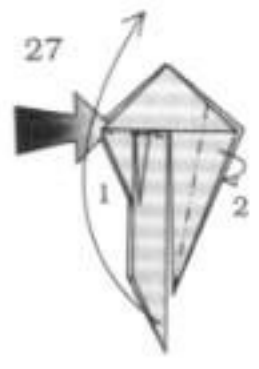

27

1. Reverse-fold.  
2. Repeat behind.



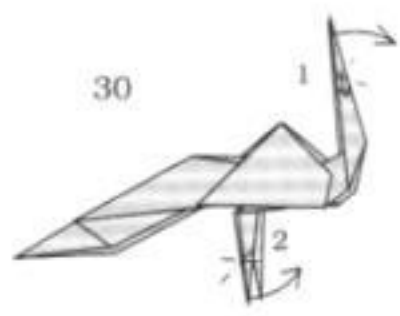
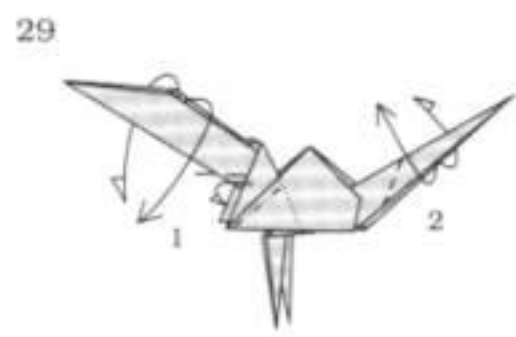
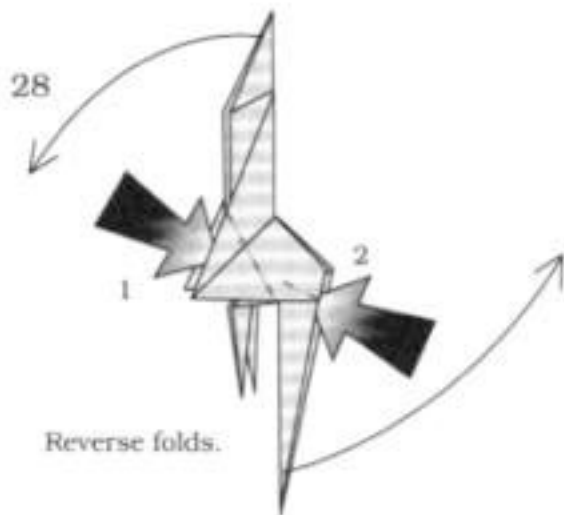

1. Spread the paper to form the head.
2. Crimp-fold, repeat behind.

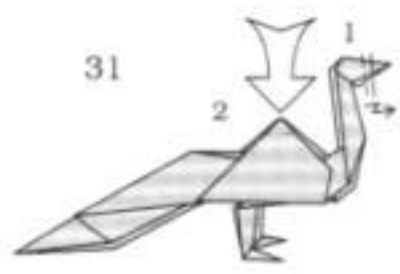

1. Crimp-fold.
2. Sink.

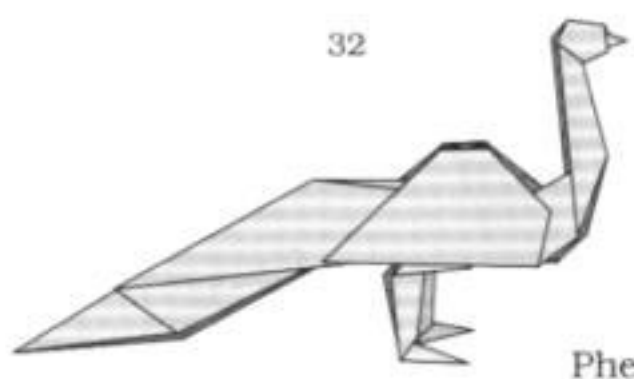

Pheasant

# Seagull

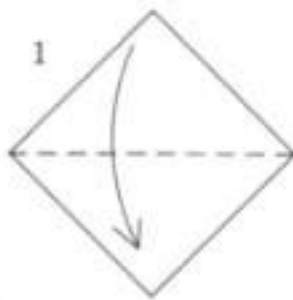
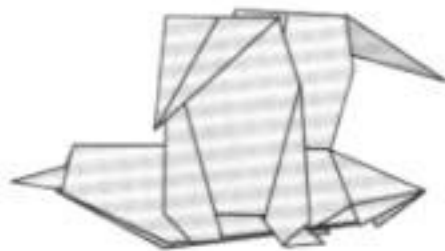

Fold and unfold.



Fold and unfold.



Fold the corner  
to the line.

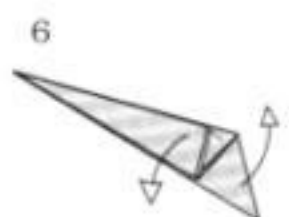
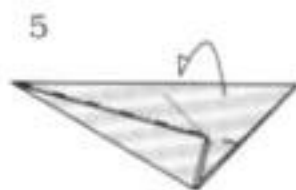

Unfold.

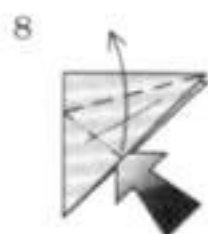

Squash-fold.

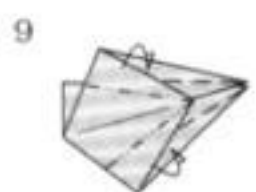

Reverse folds.

10



Turn over and rotate.

11

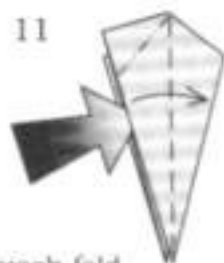

Squash-fold.

12

Fold in half  
and rotate.

13



Repeat behind.

14

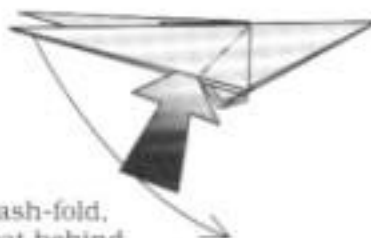
Squash-fold,  
repeat behind.

15

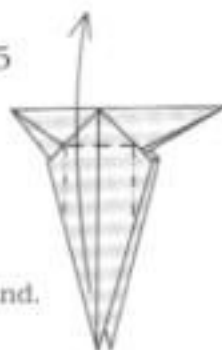
Petal-fold,  
repeat behind.

16

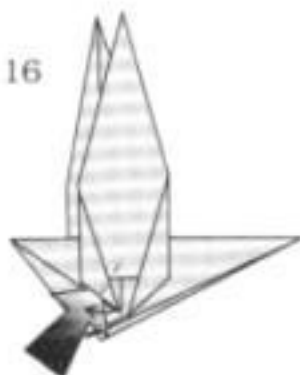
Reverse-fold,  
repeat behind.

17



Repeat behind.

18

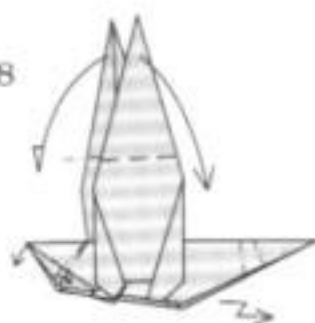
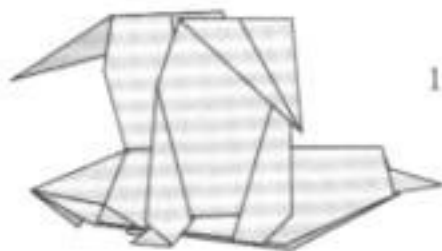
Crimp-fold the  
tail and beak.

19

Seagull

# Hummingbird

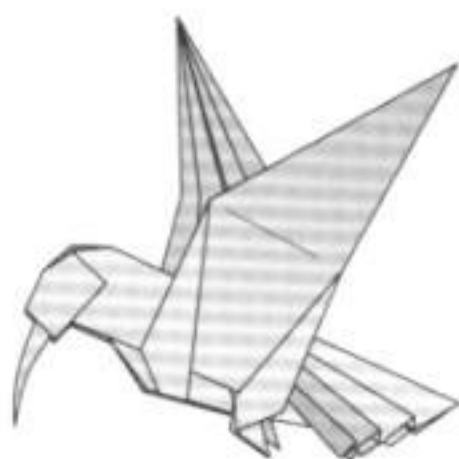

1



Fold and unfold along the diagonals.

2

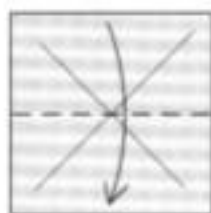

3



Fold the corner to the top.

4



5



6

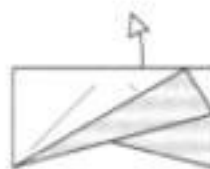

Open.

7

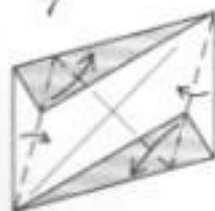

Squash folds.

8



Fold in half and rotate.

9



Squash-fold, repeat behind.

10



Petal-fold, repeat behind.

11

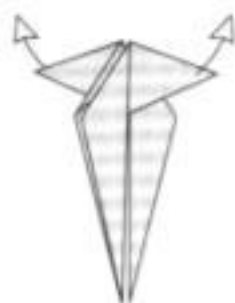

Pull out, repeat behind.

12



Squash-fold, repeat behind.

13



Petal-fold.

14

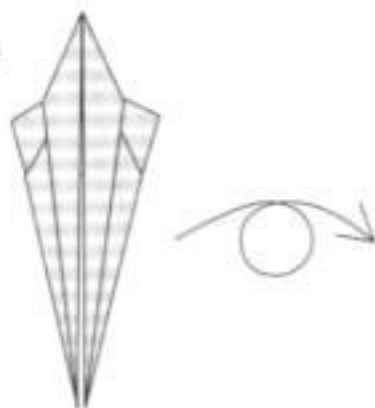

15



Bring the dots together.

16



Fold and unfold.

17



18



19



20



21



22



Fold at an angle of one-third.

23



24



Squash-fold,  
repeat behind.

25

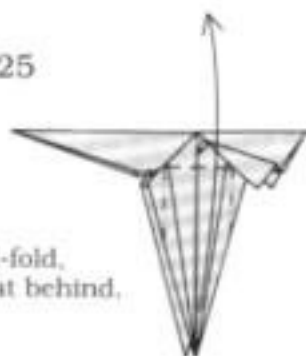

Petal-fold,  
repeat behind.

26

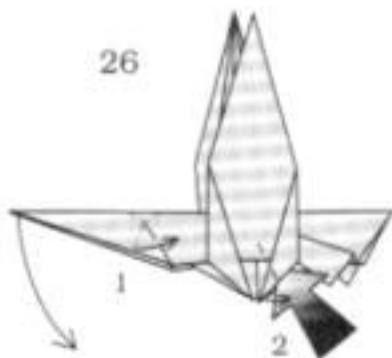

1. This is similar to a crimp fold.  
2. Reverse-fold, repeat behind.

27

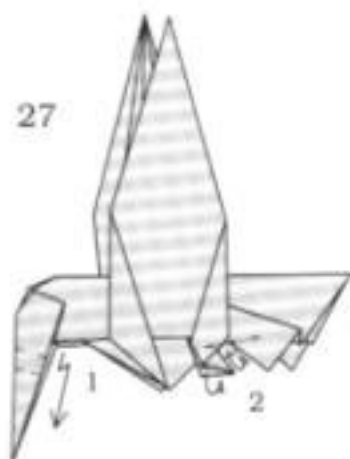

1. Crimp-fold.  
2. Repeat behind.

28

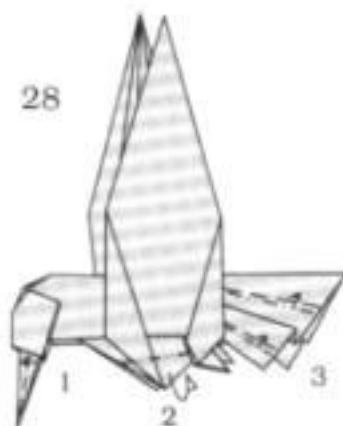

Repeat behind.

29

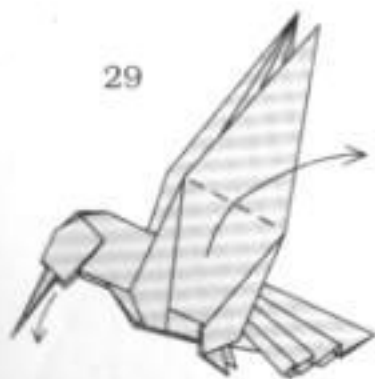

Repeat behind.

30

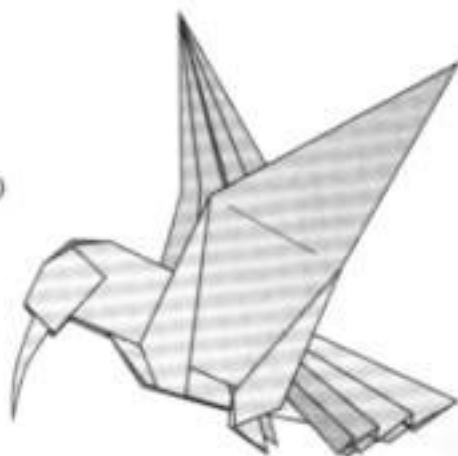

Hummingbird

# Cardinal

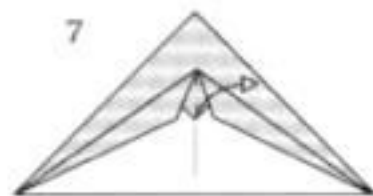
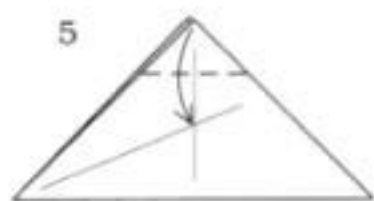
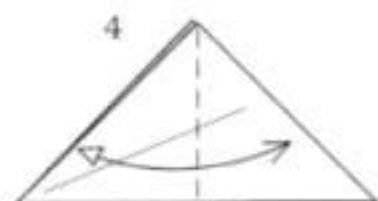
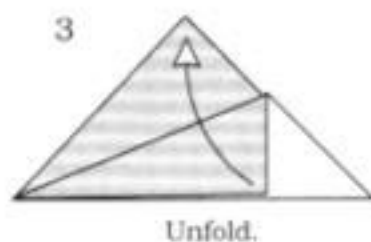
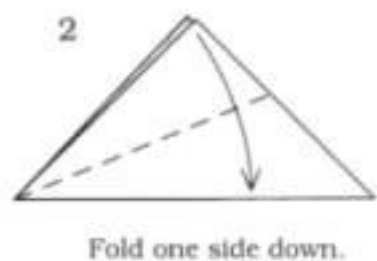
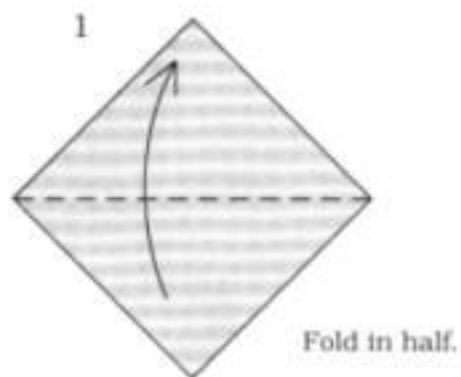

Pull out the corner.

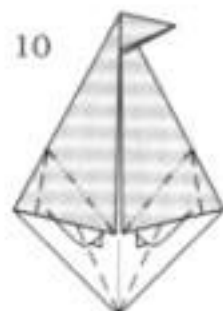
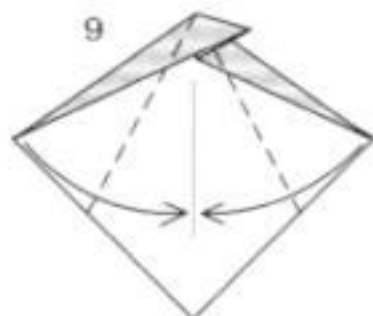
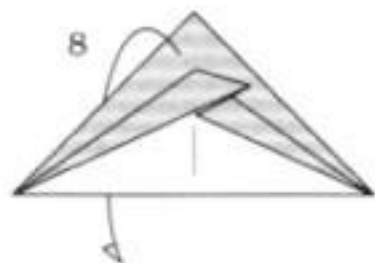

11



Fold down and unfold.

12



Rabbit ears.

13

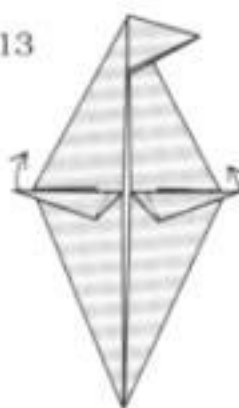

14



Spread-squash-fold.

15



16

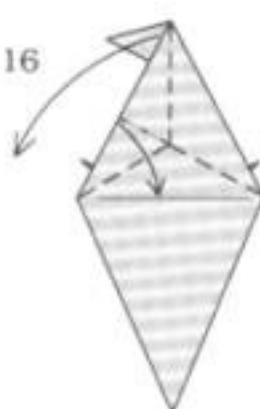

Rabbit-ear.

17



Unfold.

18



19

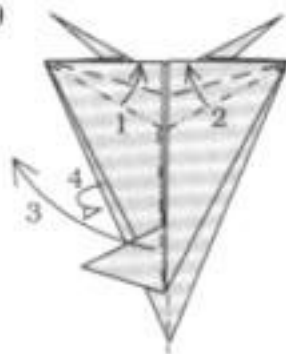

20



Crimp-fold.



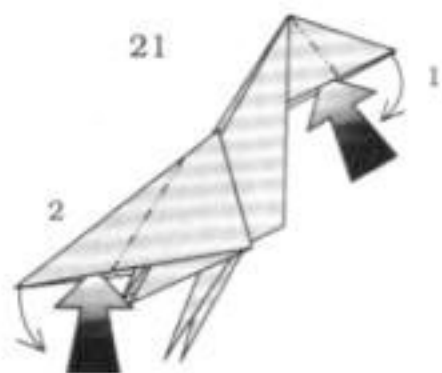

Reverse folds.



Repeat behind.

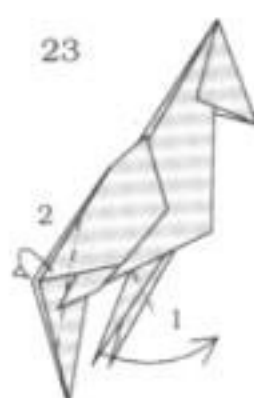

Repeat behind.

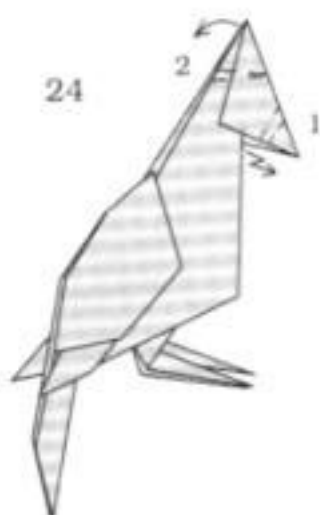

Reverse folds,  
repeat behind.



1. Sink.  
2. Crimp-fold.

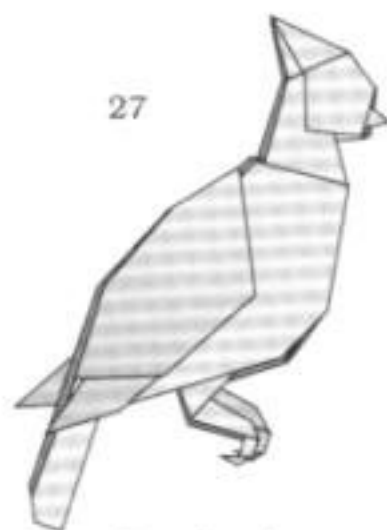

Cardinal

# Cormorant

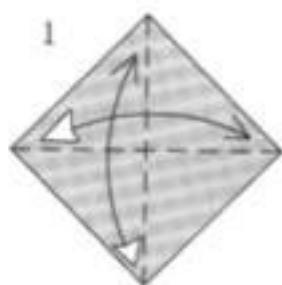
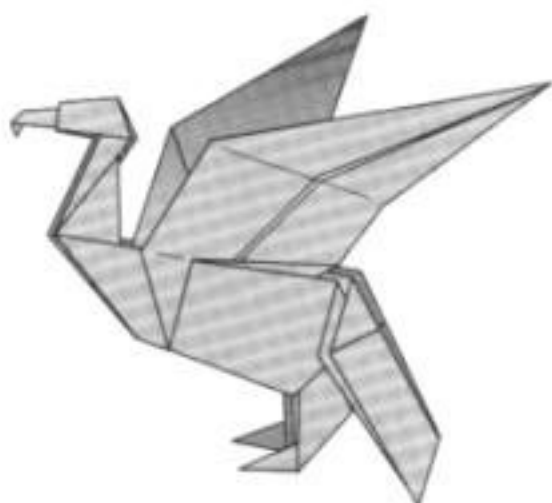

1  
Fold and unfold  
along the diagonals.

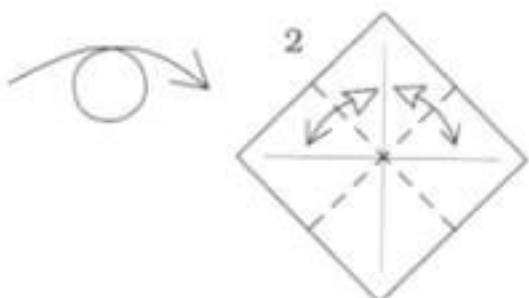

2  
Fold and unfold.

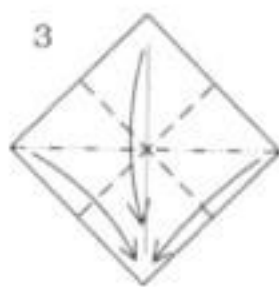

3  
Collapse the square  
by bringing the four  
corners together.

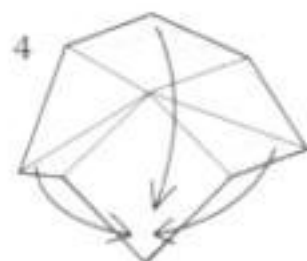

4  
This is a three-  
dimensional  
intermediate step.



5  
Kite-fold.

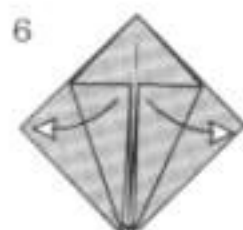

6  
Unfold.

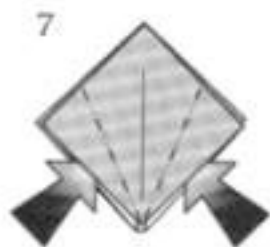

7  
Reverse folds.

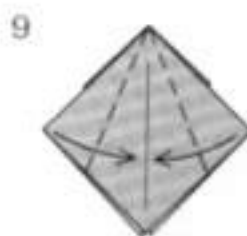

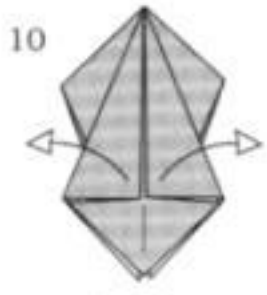

Unfold.

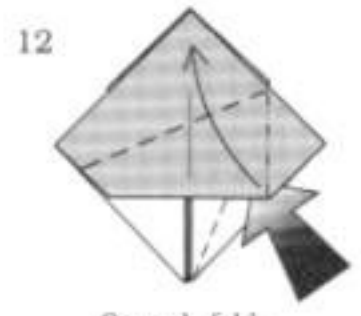
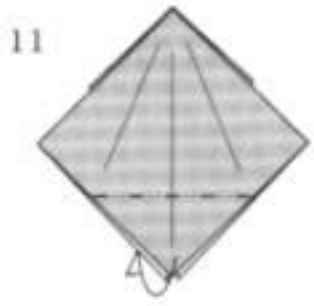

Squash-fold.

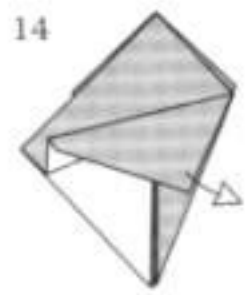
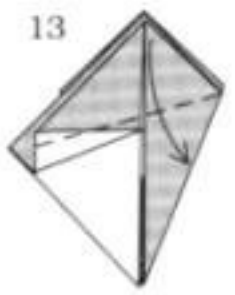

Unfold.

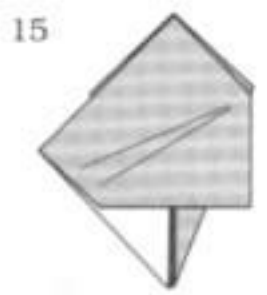

Repeat steps 12-14 on the left.

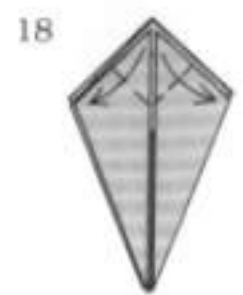
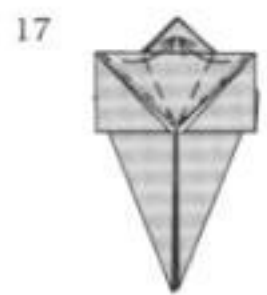
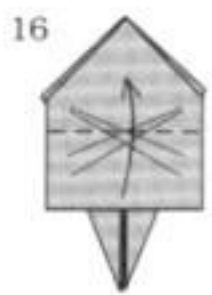

Squash-fold.



Repeat step 20 on the left.

22



Reverse folds.

23

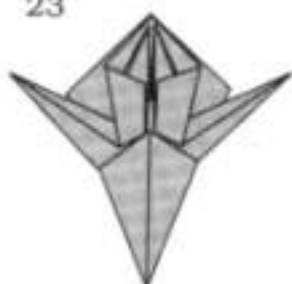

24

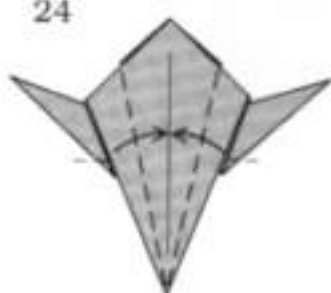

25

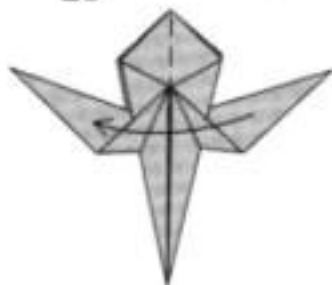

26

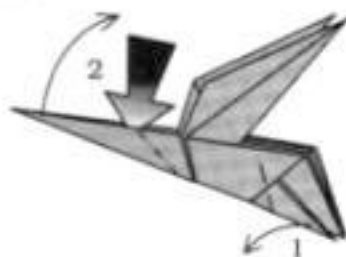

1. Valley-fold, repeat behind.  
2. Reverse-fold.

27

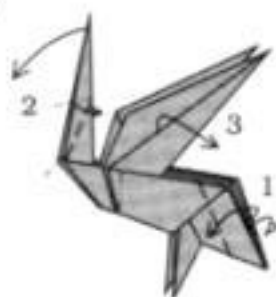

1. Outside-reverse-fold.  
2. Crimp-fold.  
3. Open the wings.

28

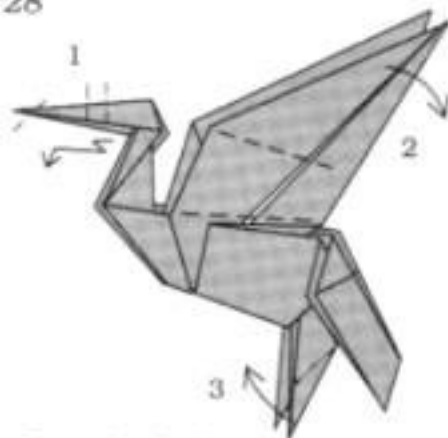

Repeat behind.

29

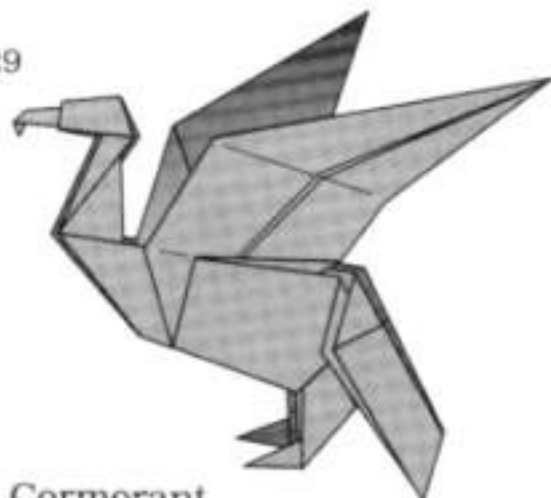

Cormorant

# Stork

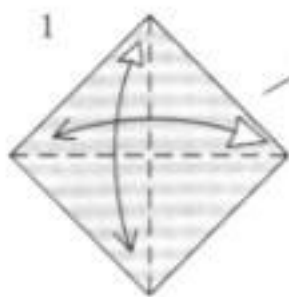
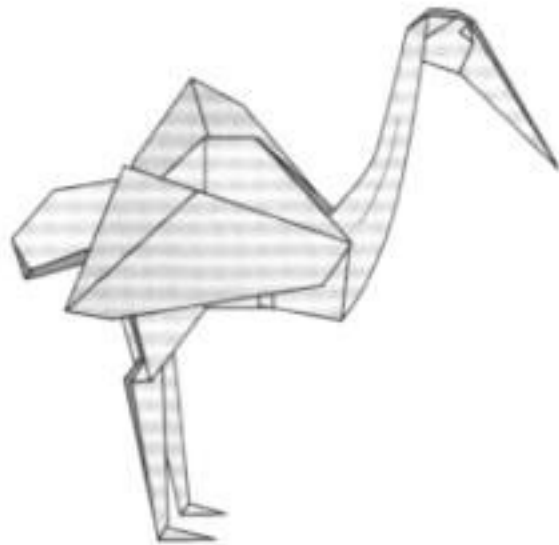

1  
Fold and unfold  
along the diagonals.

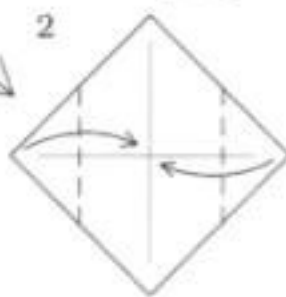

2  
Fold the corners  
to the center.

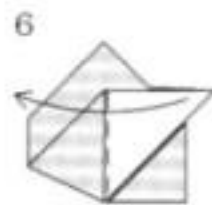
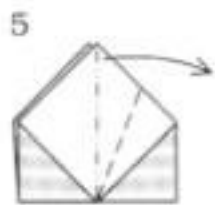
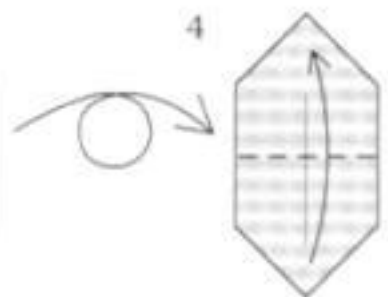

7  
Reverse-fold.

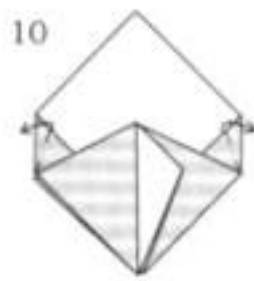
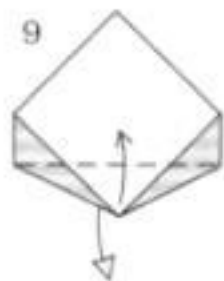

10  
Pull out.

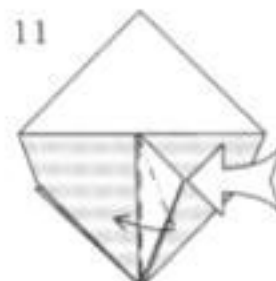

11  
Spread-squash-fold.

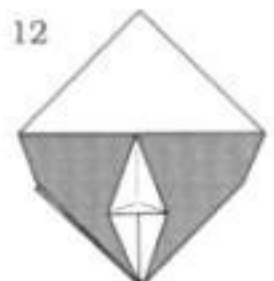

12  
Bring the dark  
paper to the front.

13

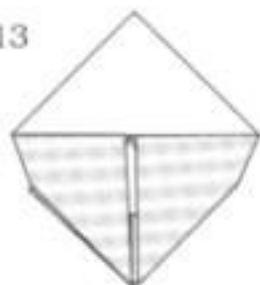

14

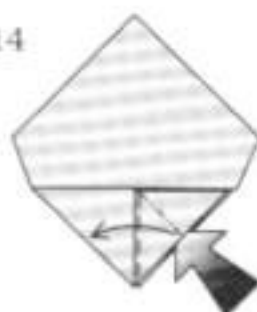

Squash-fold.

15



Fold and unfold.

16

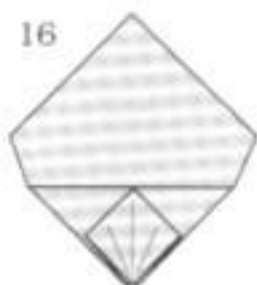

17



Fold and unfold.

18

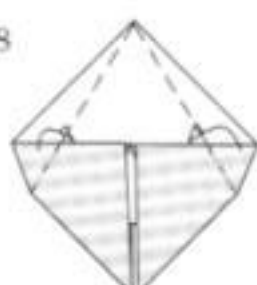

Reverse-folds.

19

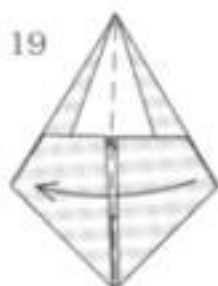
Fold in half  
and rotate.

20



Squash-fold.

21

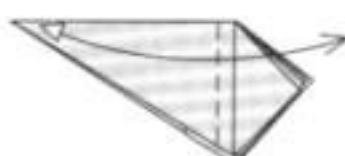

Fold and unfold.

22

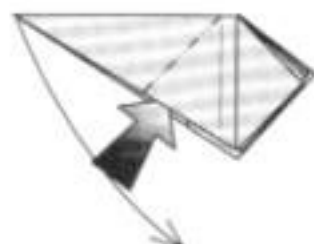

Reverse-fold.

23

Petal-fold,  
repeat behind.

24



25



Petal-fold.

26



27



Repeat behind.

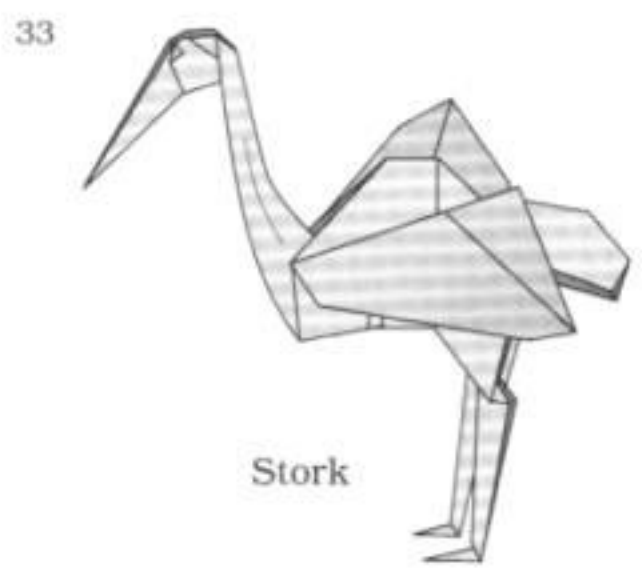
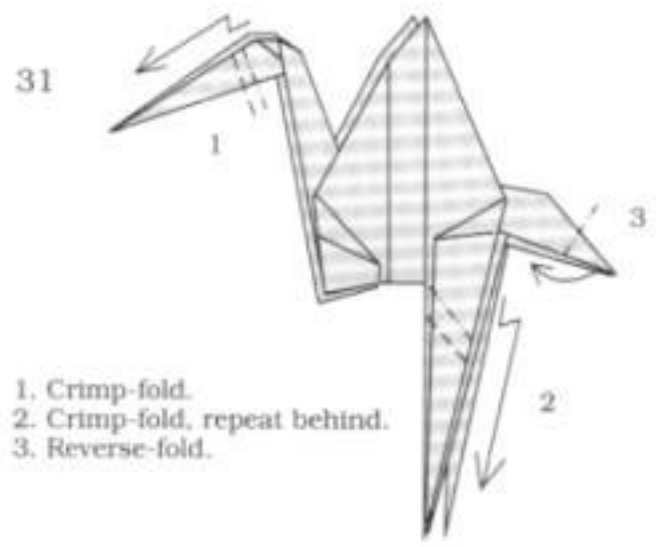
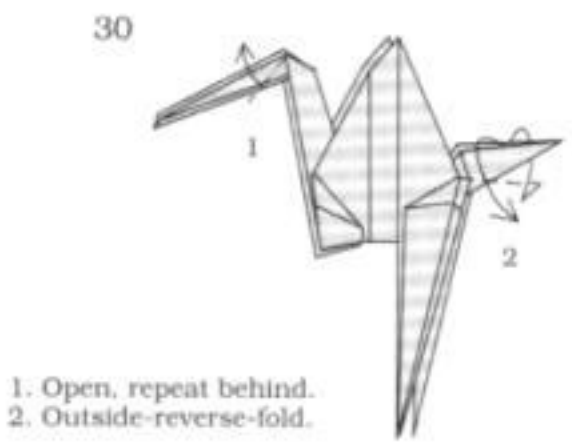
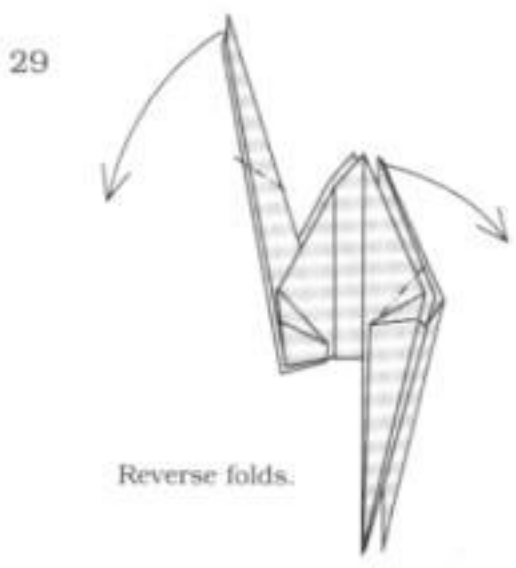
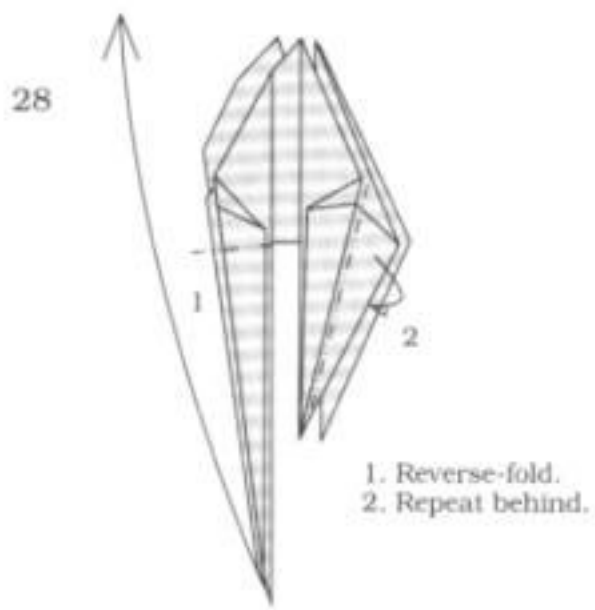

# Eagle

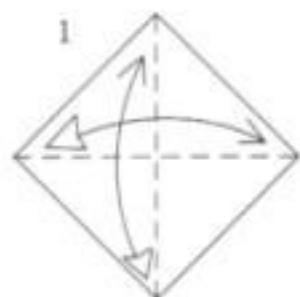
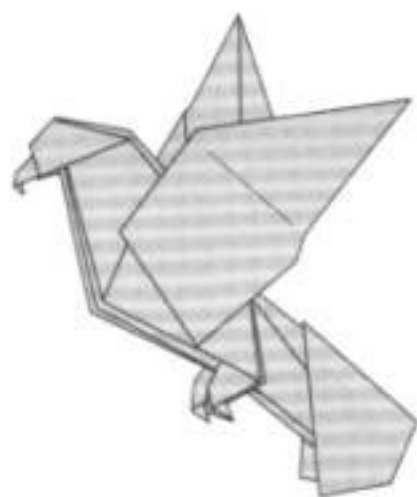

1  
Fold and unfold  
along the diagonals.

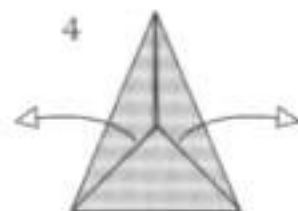
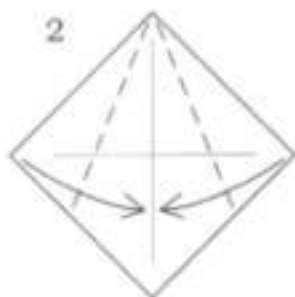

4  
Pull out the corners.

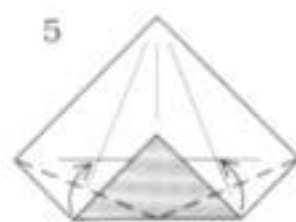

5  
6  
Fold in half and rotate.



7  
Squash-fold.

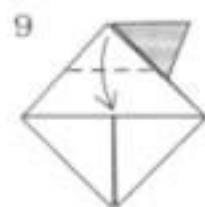
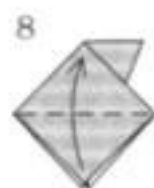

8  
9  
10  
Unfold.

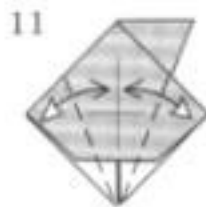

11  
Fold and unfold.

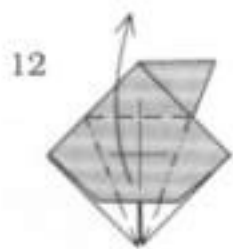

12  
Petal-fold.



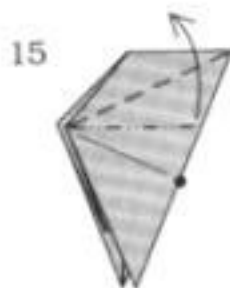
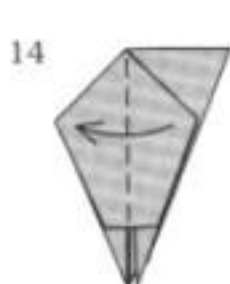
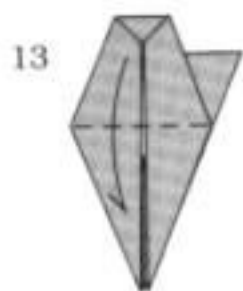

Check where the dot ends up in the next step. Repeat behind.

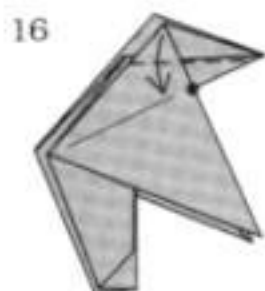

Repeat behind.



Squash-fold, repeat behind.

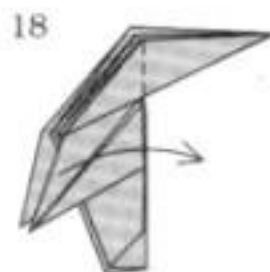

Repeat behind.

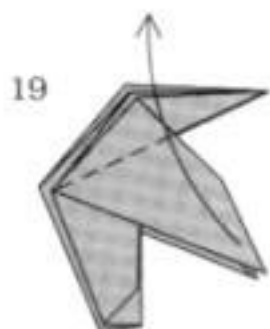

Repeat behind.

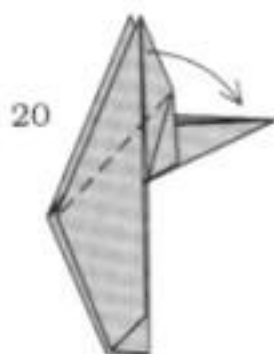

Repeat behind.

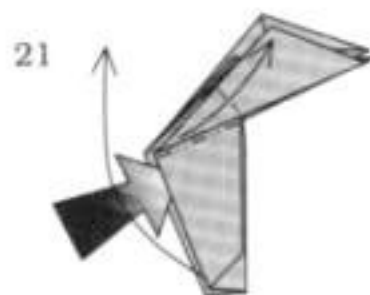

Squash-fold.

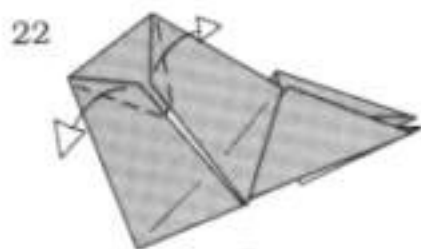

Pull out.

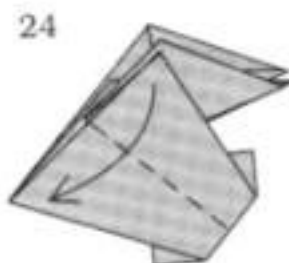
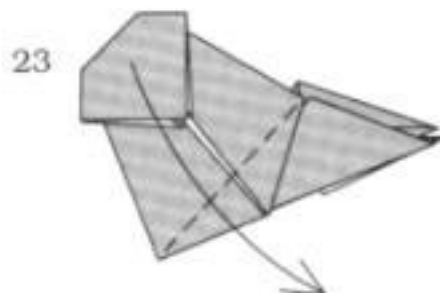

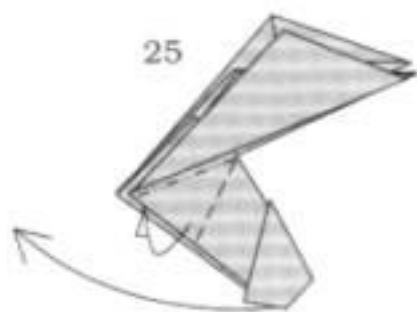

Crimp-fold.

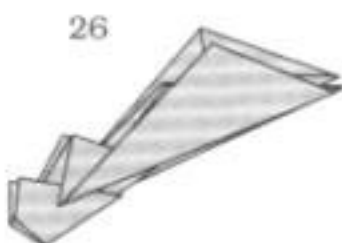

Rotate.



Reverse-fold,  
repeat behind.



Reverse-fold,  
repeat behind.

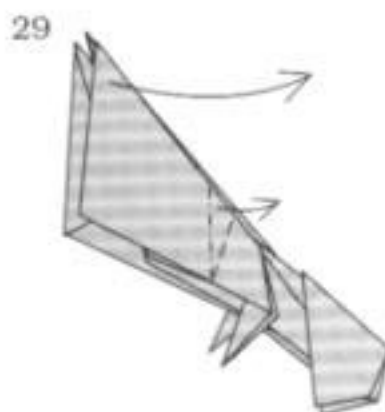

Squash-fold,  
repeat behind.

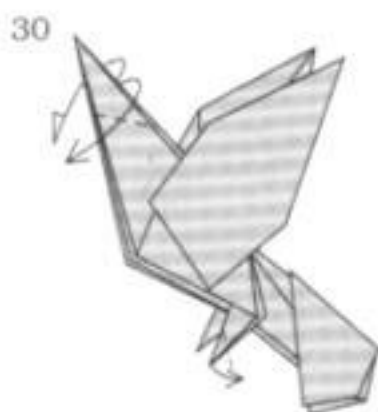

Outside-reverse-fold the  
head. Reverse-fold the  
feet. repeat behind.

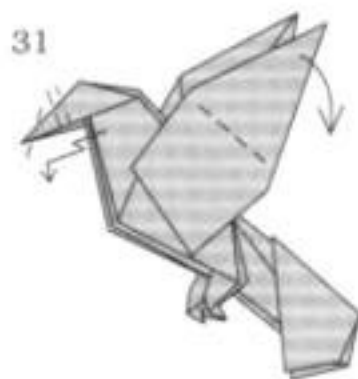

Repeat behind.

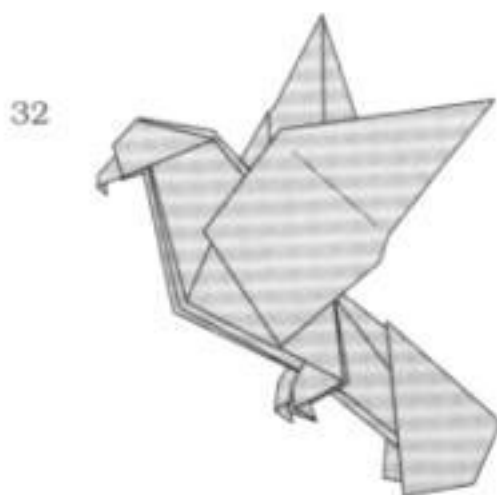

Eagle

# Canary

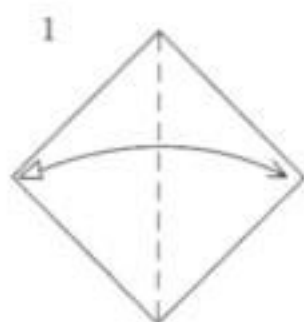
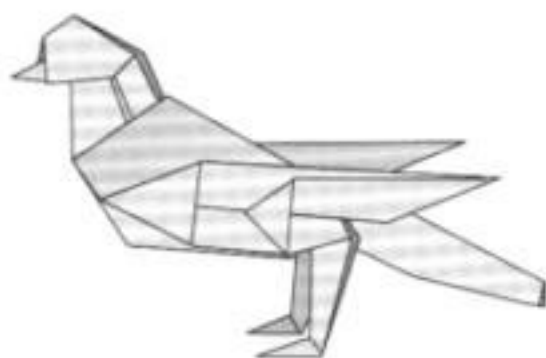

Fold and unfold.

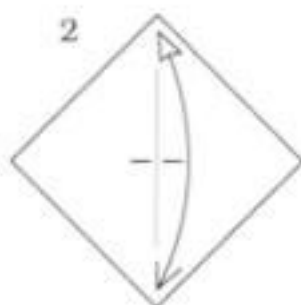

Fold up and unfold, creasing only the center.

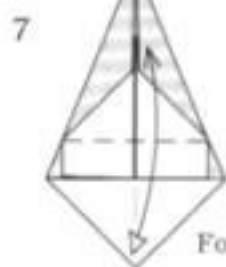
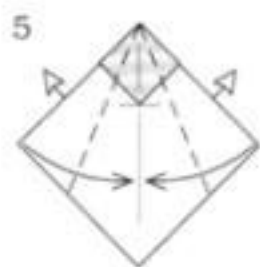
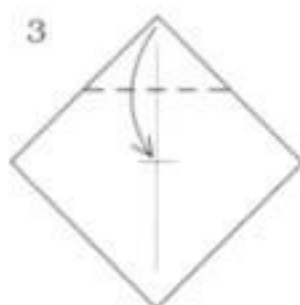

Fold and unfold.

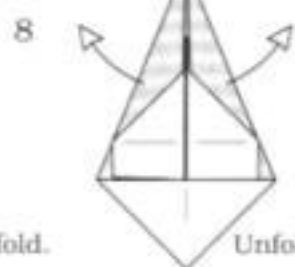

Unfold.

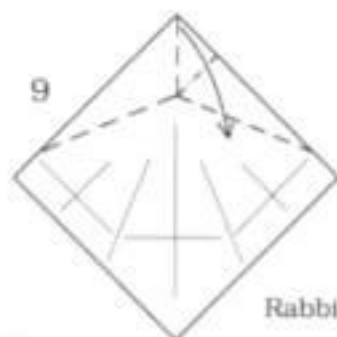

Rabbit-ear.



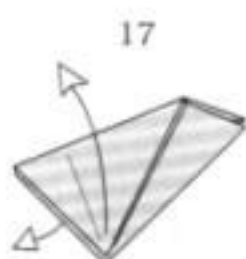
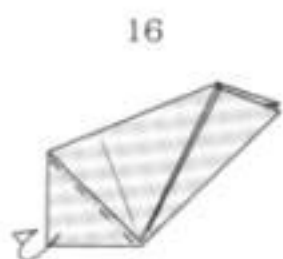
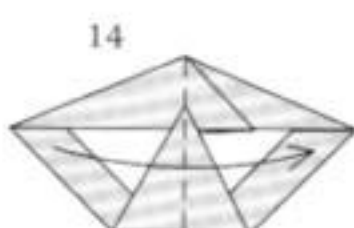
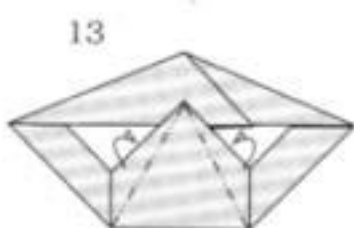
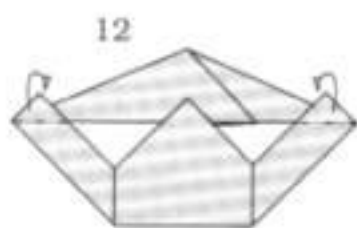

Unfold.

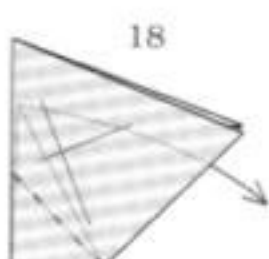

Pull out the  
inside flap.

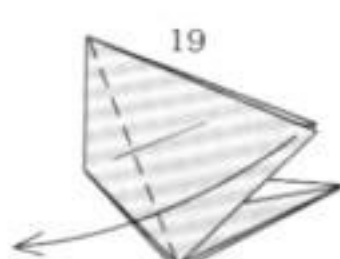

Repeat behind  
and rotate.

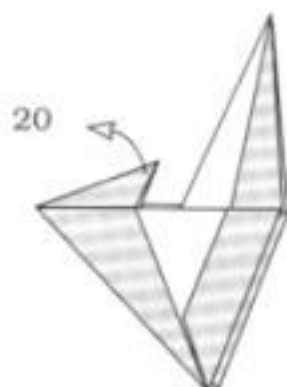

Crimp-fold.

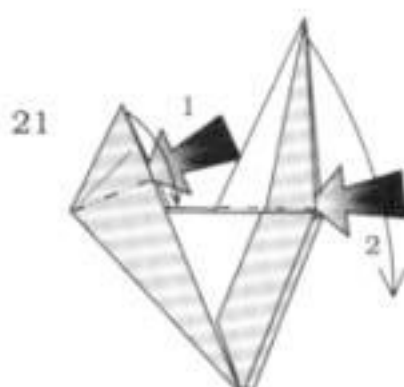

Reverse folds.

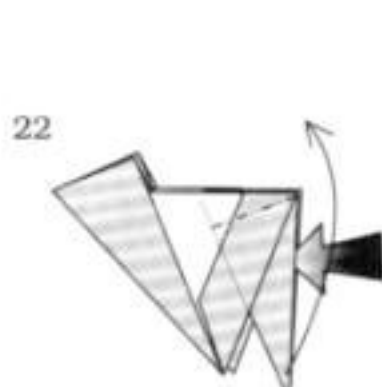

Reverse-fold.

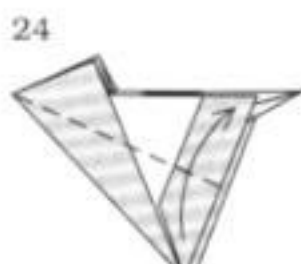
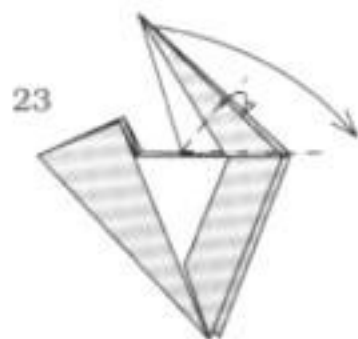

Repeat behind.



Reverse-fold,  
repeat behind.

26



Reverse-fold,  
repeat behind.

27

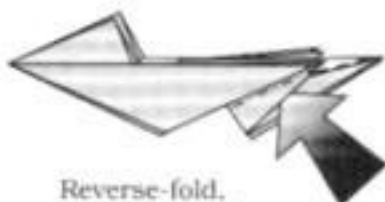

Reverse-fold,  
repeat behind.

28



Spread-squash-fold the  
wing, repeat behind.

29

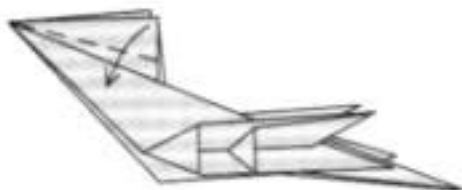

Fold at an angle of one-third,  
repeat behind.

30

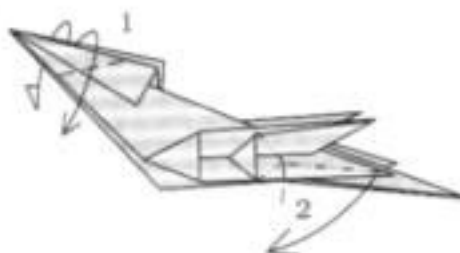

1. Outside-reverse-fold.  
2. Double-rabbit-ear.  
repeat behind.

31

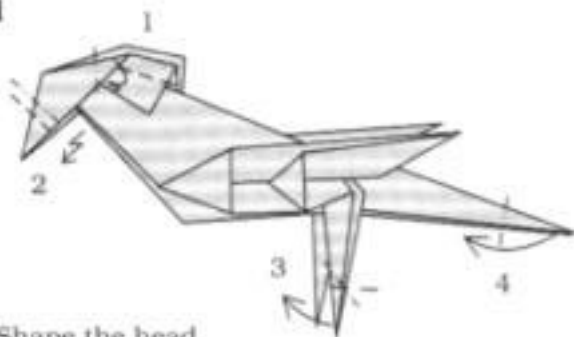

1. Shape the head.  
2. Form the beak.  
3. Shape the foot.  
4. Reverse-fold the tail.  
Repeat behind.

32

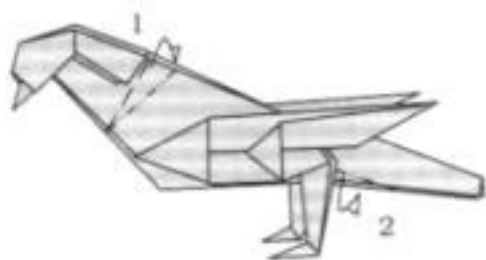

1. Crimp-fold.  
2. Repeat behind.

33

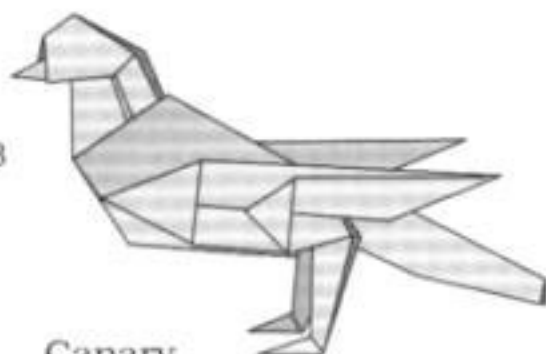

Canary

# Parrot

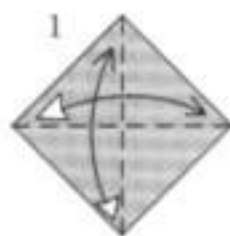
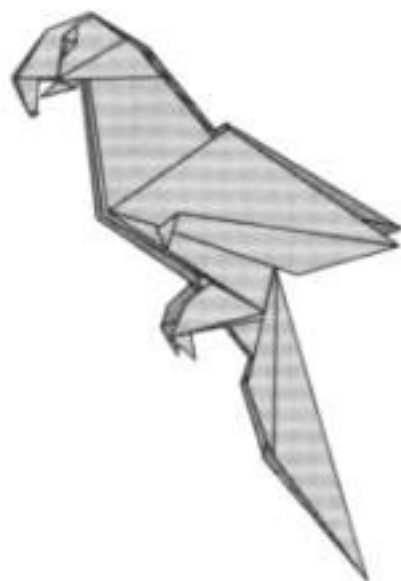

1  
Fold and unfold  
along the diagonals.

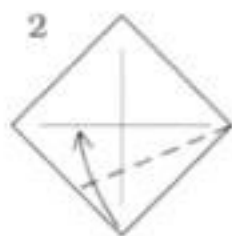

2  
Crease lightly.

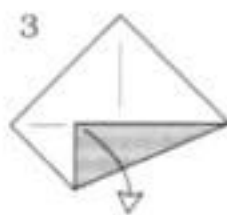

3  
Unfold.

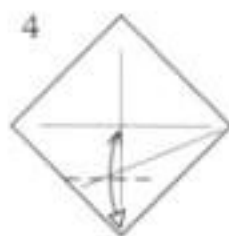

4  
Fold up to the center  
and unfold. Crease  
lightly and only on  
the left side.

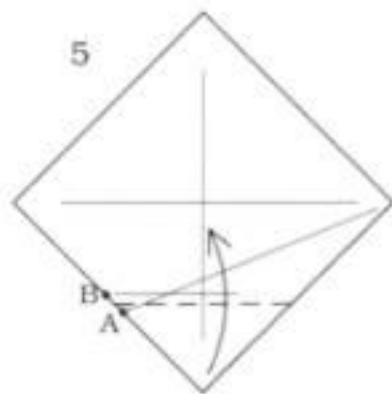

5  
Fold up so that A meets the  
line above it, close to B.

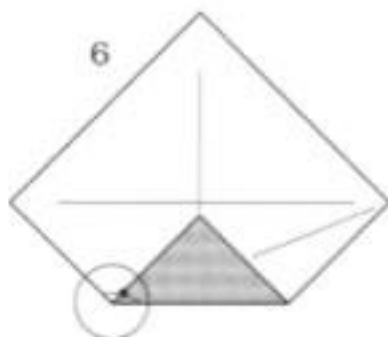

6  
Note how the  
creases intersect  
inside the circle.

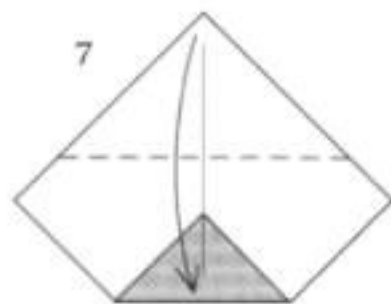

8

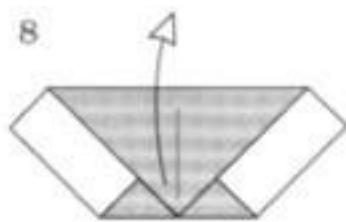

Unfold.

9

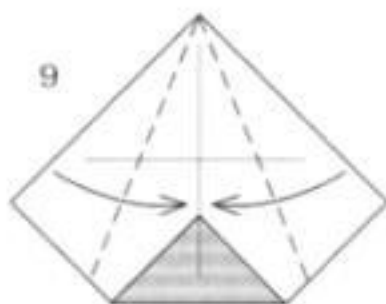

10

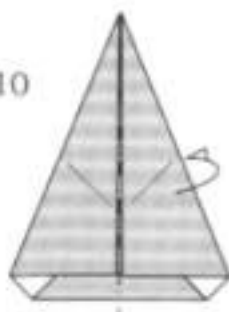
Fold in half  
and rotate.

11



Reverse-fold.

12

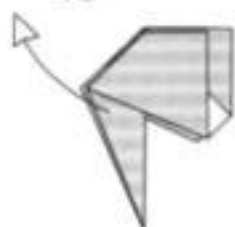

Unfold and rotate.

13

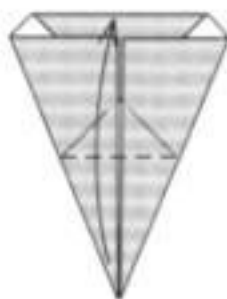

14

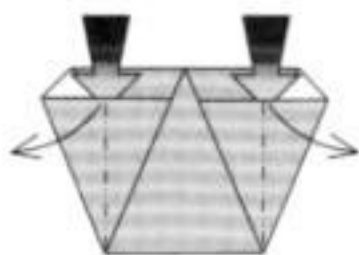

15



16

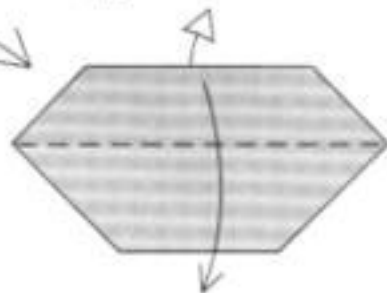

17

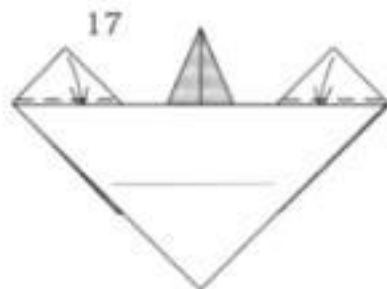

Tuck inside and rotate.

18

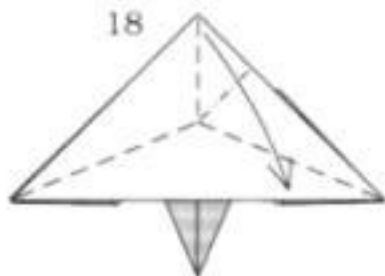

Rabbit-ear.

19

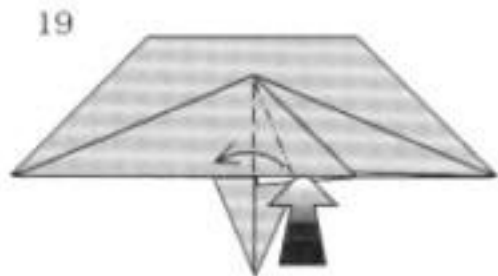

Squash-fold.

20



Petal-fold.

21

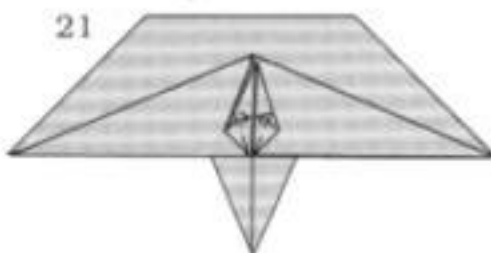

22

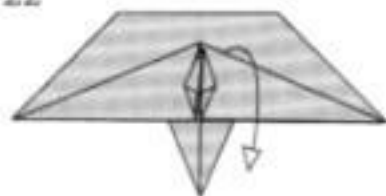

Unfold.

23

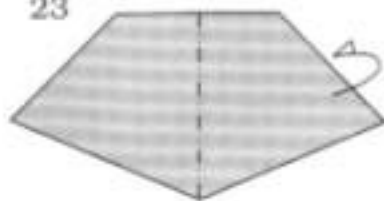

24

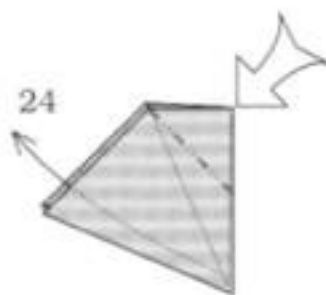

Pull out the inside flap.

25

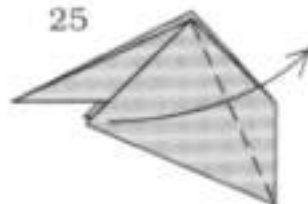

Repeat behind and rotate.

26

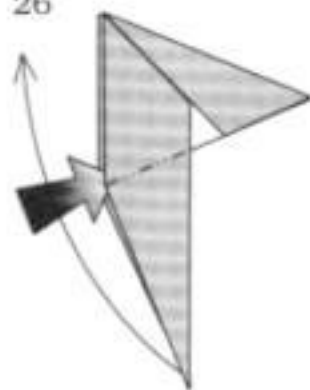

Reverse-fold.

27

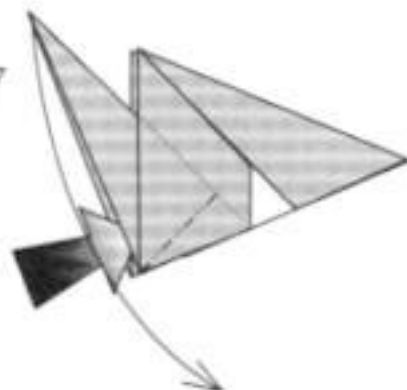

Reverse-fold on the existing crease and rotate.

28

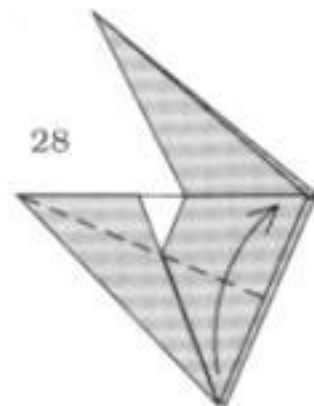

Repeat behind.

29

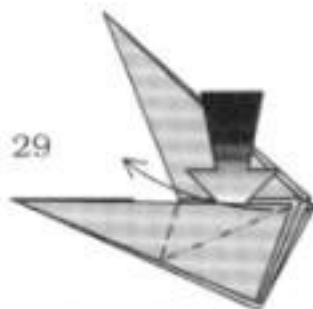

Squash-fold, repeat behind.

30

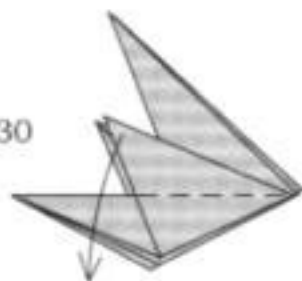

Repeat behind.

31

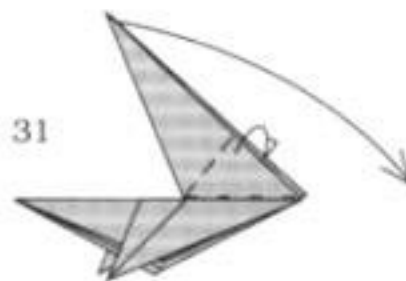

Crimp-fold,



32



Squash-fold, repeat behind.

33



Squash-fold, repeat behind.

34



Squash-fold, repeat behind.

35



Outside-reverse-fold.

36



1. Crimp-fold the lower beak.  
2. Reverse-fold, repeat behind.

37

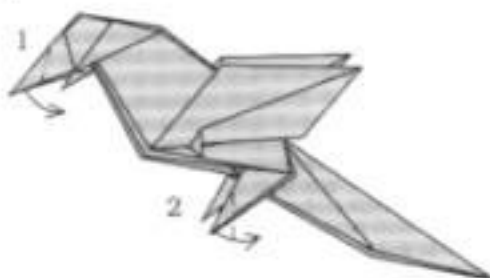

1. Reverse-fold.  
2. Reverse-fold, repeat behind.

38

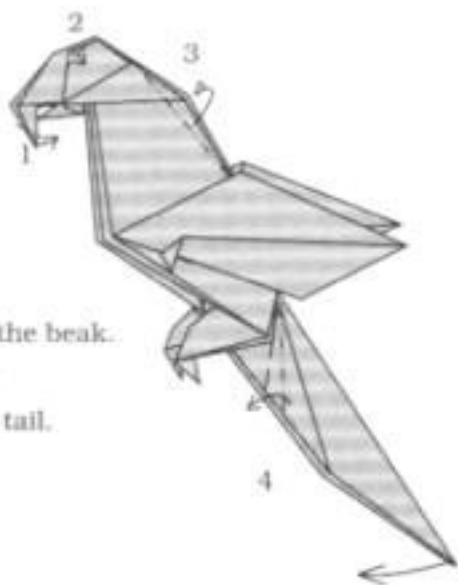

1. Fold the tip of the beak.  
2. Form the eyes.  
3. Fold the neck.  
4. Crimp-fold the tail.  
Repeat behind.

39

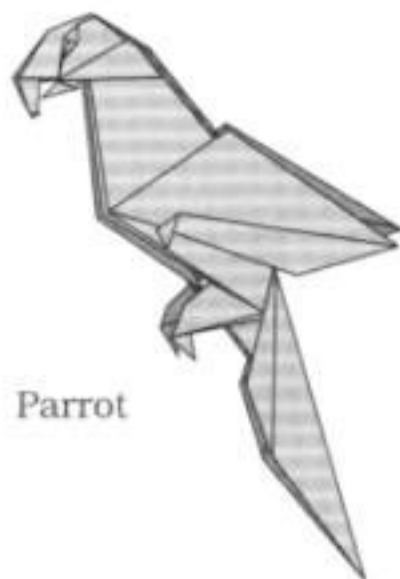

Parrot



# BIRDS IN ORIGAMI

John Montroll

With this expert guide from origami expert John Montroll you can learn to fold charming versions of a flock of favorite birds: swan, flamingo, duck, stork, goose and other popular varieties—over a dozen in all. Easy-to-follow instructions and clearly outlined diagrams show you exactly how to proceed. In addition, the projects are graded according to difficulty. Beginners will find helpful explanations of symbols and basic folds that will enable them to quickly grasp the fundamentals of paperfolding, while experienced folders will find stimulation and enjoyment in a selection of challenging projects.

Original Dover (1994) publication. Approximately 500 black-and-white illustrations. Instructions. 48pp. 8½ × 11. Paperbound.

#### ALSO AVAILABLE

ORIGAMI INSIDE-OUT, John Montroll. 120pp. 8½ × 11. 27674-0 Pa. \$9.95

EASY ORIGAMI, John Montroll. 48pp. 8½ × 11. 27298-2 Pa. \$2.95

AFRICAN ANIMALS IN ORIGAMI, John Montroll. 160pp. 7 × 10. 26977-9 Pa. \$9.95

ANIMAL ORIGAMI FOR THE ENTHUSIAST, John Montroll. 128pp. 9 × 12. 24792-9 Pa. \$8.95

ORIGAMI FOR THE ENTHUSIAST, John Montroll. 128pp. 9 × 12. 23799-0 Pa. \$6.95

ORIGAMI SCULPTURES, John Montroll. 144pp. 6½ × 9½. 26587-0 Pa. \$9.95

ORIGAMI FROM ANGELFISH TO ZEN, Peter Engel. 256pp. 9 × 12. 28138-8 Pa. \$12.95

Free Full-Color Children's Book Catalog (59071-2) available upon request.

Cover design by Frank J. Moore

ISBN 0-486-28341-0



9 780486 283418

◆3.50 IN USA