

Maarten Geerdes
Rénard Chaigneau
Oscar Lingiardi
Ron Molenaar
Rob van Opbergen
Yongzhi Sha
Peter Warren

Modern Blast Furnace Ironmaking

an introduction

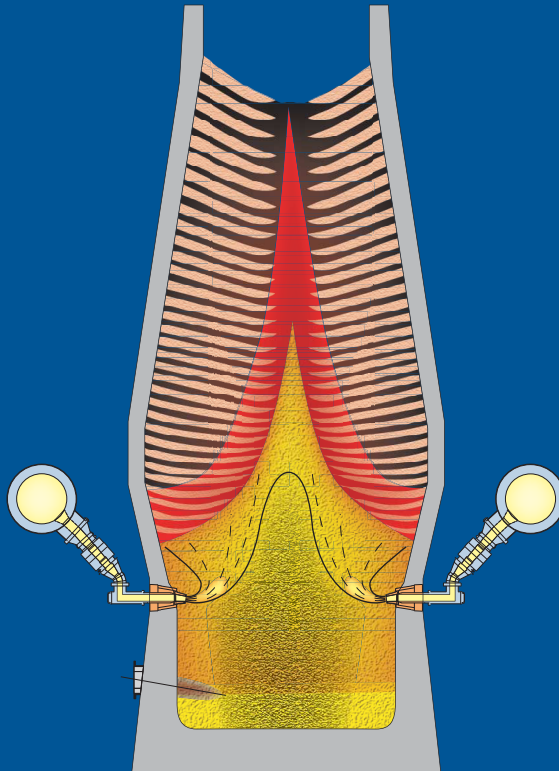

Fourth Edition, 2020

This book describes the principles of the blast furnace process. As a starting point, the blast furnace is seen as a simple iron ore melter, while gradually the physical, chemical and metallurgical background of the blast furnace process is clarified. The book focuses on the control of the process with respect to thermal control, gas flow control and casthouse operation. In this book, all essential process details are described and a special focus is on cost optimization by low coke rates and on management of the process in case of disturbances and upsets. The optimization of the blast furnace is not only based on "best practice transfer", but also requires conceptual understanding why a measure works in some cases and not in other cases. In other words, operational improvement is not only based on know-how, but as well on know-why. This publication can be used as an introductory text for students of metallurgy as well as for blast furnace operators and management.



Maarten Geerdes

The Netherlands, 1951

PhD in Chemistry, former Blast Furnace Technical Manager. Currently working as an Ironmaking Consultant.



Rénard Chaigneau

The Netherlands, 1965

PhD in Raw Materials Processing, working as Senior Manager Technical Marketing of iron ore at Baffinland.



Oscar Lingiardi

Argentina, 1955

MSc Chemical Engineering, MBA. Has been working as Ironmaking Technical Specialist at Ternium for most of his career.



Ron Molenaar

The Netherlands, 1946

Degree in Mechanical Engineering, former Blast Furnace General Manager, Senior General Manager Ironmaking Technology.



Rob van Opbergen

The Netherlands, 1961

BSc Technical Management, former Blast Furnace Shift Manager. Currently Manager Operational Assistance at Danieli Corus.



Yongzhi Sha

PR China, 1963

Professor and Director of the Ironmaking Department at the China Iron & Steel Research Institute in Beijing.



Peter Warren

United Kingdom, 1962

MEng in Chemical Engineering, worked mostly in blast furnace research, currently Senior Technologist at Scunthorpe.



ISBN 978-1-64368-122-1 (print)
ISBN 978-1-64368-123-8 (online)

Delft University Press is an imprint of IOS Press



Modern
Blast Furnace
Ironmaking
an introduction

This page intentionally left blank

**Maarten Geerdes
Rénard Chaigneau
Oscar Lingardi
Ron Molenaar
Rob van Opbergen
Yongzhi Sha
Peter Warren**

Modern Blast Furnace Ironmaking

an introduction

Fourth Edition, 2020

© 2020 The authors and IOS Press. All rights reserved.

ISBN 978-1-64368-122-1 (print)
ISBN 978-1-64368-123-8 (online)
DOI 10.3233/STAL9781643681238

Published by IOS Press under the imprint Delft University Press

Publisher

IOS Press BV
Nieuwe Hemweg 6b
1013 BG Amsterdam
The Netherlands
tel: +31-20-688 3355
email: info@iospress.nl
www.iospress.nl

LEGAL NOTICE

The publisher is not responsible for the use which might be made of the following information.

PRINTED IN SLOVENIA



Preface

This fourth edition of “Modern Blast Furnace Ironmaking” has been prepared by an international staff of experts from three continents. We are indebted to Cor van der Vliet and Hisko Toxopeus†, who prepared the first two editions of the book and agreed to hand over future editions of the book to the next generation. Prof. Ivan Kurunov† and John Ricketts made a great contribution to the third edition. Co–authors of the fourth edition are Prof. Yongzhi Sha from the China Iron and Steel Research Institute, Ron Molenaar, retired superintendent of the IJmuiden Blast Furnaces and Peter Warren, presently working at British Steel in the United Kingdom and Rob van Opbergen, experienced in casthouse operation and operational improvement.

The objective of the book is to share our insights, that optimization of the blast furnace is not only based on “best practice transfer”, but also requires conceptual understanding of *why* a measure works. In other words, operational improvement is based not only on know–how, but also on know–why.

Compared to the third edition, we have added operational examples of many furnaces. The examples are for illustration only and cannot be traced to a specific furnace. Since the earlier edition, new instrumentation like cameras at tuyeres and the top are playing a much more prominent role. We have rewritten the sections on balances and elaborated the section on operational challenges.

We are indebted to the many colleagues we have worked with. We are grateful to Jennifer Wise–Alexander and Tim Vander, who will find part of their contributions to the second edition in the book. Edo Engel did the editing, as in the previous three editions. Danieli Corus supported publication of the book.

For the fourth edition we enjoyed support from many colleagues worldwide. We are indebted to N. Bleijendaal, J. Borrego and L. Castro (AHMSA, Mexico), P. Etchevarne (Ternium, Argentina), D. Fisher (British Steel, UK), G.J. Gravemaker, Dr. B. Nightingale (Australia), T. Spiering (fellow traveler), Yuanyi Liu (China), Dr. Fuming Zhang (China) and P. Zonneveld.

We learn by sharing our knowledge. We wish the same to our readers.

Maarten Geerdes, Rénard Chaigneau, Oscar Lingiard, Ron Molenaar,
Rob van Opbergen, Yongzhi Sha, Peter Warren

September 2020

This page intentionally left blank

Contents

Preface		v
List of Symbols and Abbreviations		x
Chapter I	Introduction to the Blast Furnace Process	1
1.1	Global steel production	1
1.2	Hot metal production	2
1.3	Blast furnace process	3
1.4	Equipment	5
1.5	Book overview	10
Chapter II	Blast Furnace Process and Internal Structure	11
2.1	Gasifying coke and coal	11
2.2	Counter-current reactor	12
2.3	Internal layer structure	13
2.4	How gas flows through the furnace	16
2.5	Processing the ferrous burden	17
2.6	Furnace efficiency	18
2.7	Casting hot metal and slag	19
Chapter III	The Ferrous Burden	23
3.1	Introduction	23
3.2	Iron ore	24
3.3	Quality demands for the blast furnace burden	26
3.4	Sinter	30
3.5	Pellets	35
3.6	Lump ore	40
3.7	Metallics charge and briquettes	41
3.8	Interaction of burden components	42
3.9	Chemical control of the burden	44
Chapter IV	Coke	47
4.1	Function of coke in the blast furnace	47
4.2	Coal blends for coke making	49
4.3	Coke quality	50
4.4	Coke size distribution	54
4.5	Strength of coke	55
4.6	Coke deadman	58
4.7	Overview of international quality parameters	63
4.8	Coke, nut coke and high PCI	65

Chapter V	Injection of Coal, Natural Gas and Oil	67
5.1	Properties of coal, oil and gas	68
5.2	Coal injection	70
5.3	Natural gas injection	82
5.4	Coal–gas co–injection	85
Chapter VI	Blast Furnace Gas and Processing the Ferrous Burden	87
6.1	Introduction	87
6.2	Hot metal and slag composition	87
6.3	Top gas composition from a one–stage mass balance	89
6.4	The temperature profile and chemical reactions	91
6.5	Carbon balance: estimation of direct reduction	92
6.6	Gas and burden composition during processing	96
6.7	Permeability	102
6.8	Blast furnace efficiency	109
6.9	Productivity	111
6.10	Process symmetry	112
Chapter VII	Burden Distribution	117
7.1	The movement of gas and burden	117
7.2	Burden descent: system of vertical forces	121
7.3	Burden distribution and gas flow control	123
7.4	Coke and ore layer thickness	132
7.5	Finding an optimal burden distribution	135
7.6	Double bell furnaces	136
7.7	Permeability of cohesive zone	137
Chapter VIII	Hot Metal and Slag	141
8.1	Processing the ferrous burden above the cohesive zone	141
8.2	Softening	143
8.3	Melting	145
8.4	Formation of hot metal and slag as cast	147
8.5	Slag properties	155
Chapter IX	Casting Hot Metal and Slag	161
9.1	Introduction	161
9.2	Liquid level and the blast furnace process	162
9.3	Monitoring casting regimes	167
9.4	The taphole	172
9.5	Single taphole furnaces	177
9.6	Casting problems and remedial actions	178
9.7	Hot metal and slag separation	180

Chapter X	Control of Blast Furnace Operation and Burden Selection	183
10.1	Production level and reductant rate	183
10.2	Under control and out of control	185
10.3	What to control in daily operations?	186
10.4	Thermal control	186
10.5	Control of slag basicity	187
10.6	Control of hot blast parameters and injectant at tuyere level	188
10.7	Gas flow control	189
10.8	What should be controlled automatically?	190
10.9	Burden selection	190
Chapter XI	Operational Challenges	197
11.1	Raw materials from stockyard: fines and moisture	197
11.2	Burden descent	203
11.3	Channeling	207
11.4	Recirculation of alkali and zinc	208
11.5	Adherences to the furnace wall	211
11.6	Tuyere blockage	212
11.7	Tuyeres: failures and water leakage	213
11.8	Stops and starts	217
11.9	Casthouse challenges	224
11.10	Greenhouse gas emissions	226
Annex I	Blast Furnace Instrumentation	229
Annex II	Reference Furnace Data	233
Annex III	Rules of Thumb	234
Annex IV	The Blast Furnace as a Chemical Reactor	235
Annex V	Expert Systems and Models	242
Annex VI	Coke quality tests	248
Annex VII	Rist diagram	250
Annex VIII	References	255
Index		259

List of Symbols and Abbreviations

Δ	Delta (difference)
η	Èta (utilization)
Ω	Omega
AMS	Average Mean Size
B2, B3, B4	Basicity, ratio of 2, 3 or 4 components
CRI	Coke Reactivity Index
CSR	Coke Strength after Reaction
daN	deca Newton
HGI	Hard Grove Index
HMS	Harmonic Mean Size
HOSIM	Hoogoven Simulation (Blast Furnace Simulation)
HV	High Volatile
IV	Inner Volume
ISO	International Standardization Organization
JIS	Japanese Industrial Standard
LV	Low Volatile
MV	Mid Volatile
PCI	Pulverized Coal Injection
RAFT	Raceway Adiabatic Flame Temperature
RR	Replacement Ratio
Standard Coke	Coke with 87.5 % carbon
STP	Standard Temperature and Pressure
tHM	tonne of hot metal
VM	Volatile Matter
WV	Working Volume

I Introduction to the Blast Furnace Process

1.1 Global steel production

Countless steel products are used in nearly every aspect of our daily life. Over the last 100 years, global crude steel production has risen from 28 million tonnes in 1900 to 1.869 million tonnes in 2019, an increase of 3.6 % per year, as shown in Figure 1.1.

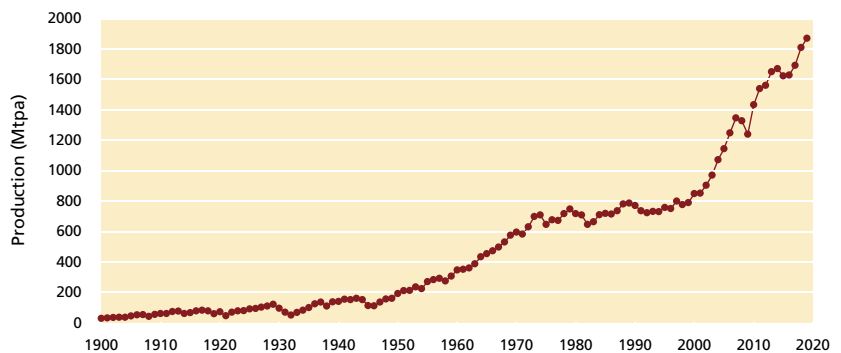

Figure 1.1 World crude steel production (World Steel Association)

Two different process routes are available for the production of steel products: the blast furnace–oxygen steelmaking and the electric arc steelmaking route. The routes differ with respect to the type of products that can be made, as well as the raw materials used.

The blast furnace–oxygen steelmaking route mainly produces flat products, while electric arc steelmaking is more focused on long products. The former uses coke and coal as the main reductant (fuel) sources and sinter, pellets and lump ore as the iron–bearing component, while the latter uses electric energy to melt scrap and DRI (direct reduced iron). The current trend is for electric arc furnaces to be capable of producing flat products as well. Nevertheless, the blast furnace–oxygen steelmaking route is the primary source for worldwide steel production: oxygen steel is about 75 % of total steel production, as shown in Figure 1.2.

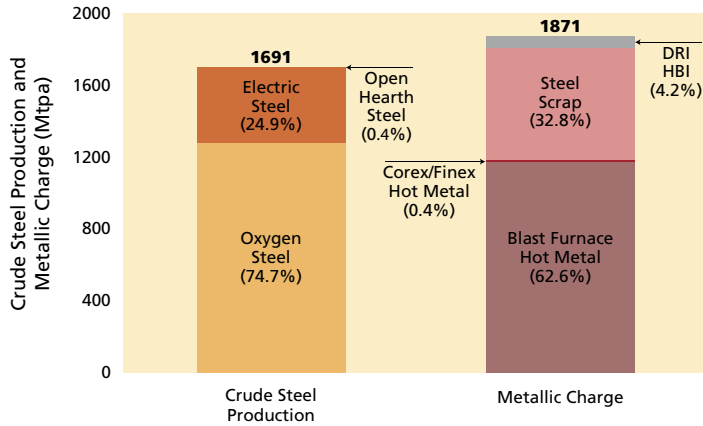

Figure 1.2 World crude steel production and metallic charge (Lüngen and Schmöle, 2018)

In total, for steelmaking the main ferrous sources are hot metal from blast furnaces (63 %) and scrap (33 %). Minor amounts from Corex/Finex (0.4 %) and some direct reduced iron and hot briquetted iron (DRI/HBI, 4 %). In iron ore mines the ferrous material is present as oxides. The oxygen of the oxides is removed by a reduction process, the most important being the blast furnace process, which is the subject of this book.

1.2 Hot metal production

Hot metal is produced from sinter, pellets and lump ores as the iron-bearing components, and coke and coal as the main reductants (fuel). Global hot metal production from the blast furnace process has risen from about 40 million tonnes in 1900 to 1278 billion tonnes in 2019. Especially during the last two decades, mainly due to the contribution from China, global blast furnace hot metal production has increased dramatically, as shown in Figure 1.3.

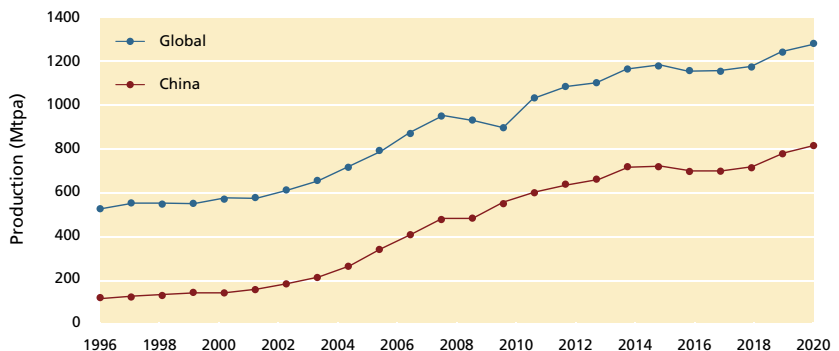

Figure 1.3 Blast Furnace hot metal production (World Steel Association)

Steel production based on hot metal from blast furnaces contributes considerably to greenhouse gas emissions: some 1500–2000 kg CO₂ is generated per tonne of steel, since the process route from the mine to the final steel product is largely based on coal for energy. It is about 6 % of total CO₂ emissions worldwide. Producing steel from scrap generates only around 25 % of the amount of CO₂, although the amount and quality of scrap cannot replace the steel produced from “virgin” iron units. This means that blast furnaces will continue to produce huge amounts annually, while improving resource efficiency by applying state-of-the-art technologies.

1.3 Blast furnace process

A blast furnace is filled with alternating layers of coke and iron ore-containing burden. The inputs and outputs of a blast furnace are shown in Figure 1.4.

- Heat and process gas are generated by gasifying coke and coal by means of preheated hot blast (up to more than 1250 °C).
- In this process, the oxygen in the blast is transformed into gaseous carbon monoxide. The resulting gas has a high flame temperature of 1900–2300 °C.
- In the process of generating hot gas, coke is consumed, and the heat of the gas is used to melt the ferrous burden. Voidage is created in this way, and the burden descends into this voidage. The gas and ferrous burden movement are illustrated in Figure 1.5 on the next page.

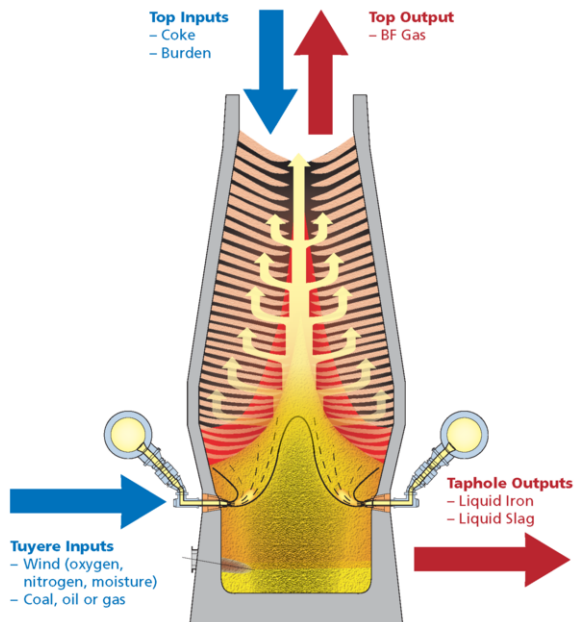

Figure 1.4 Input and output of a blast furnace

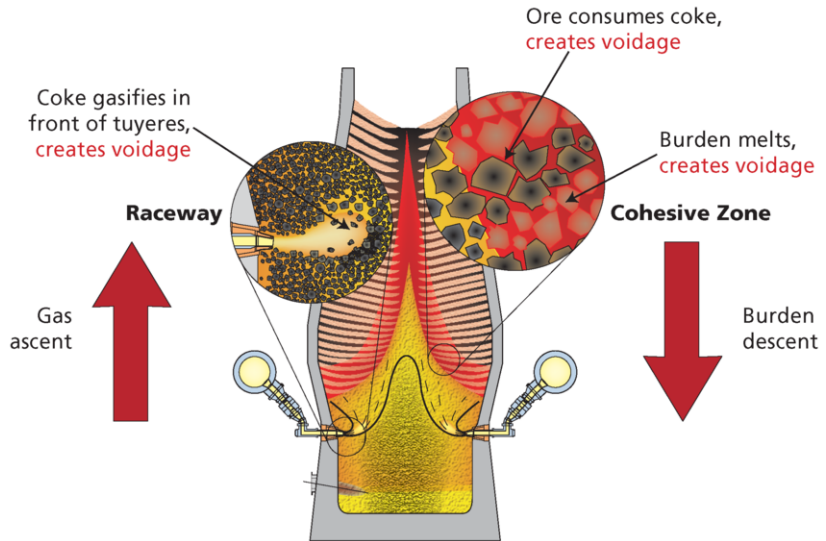

Figure 1.5 Voidage is created by gasifying coke at the tuyeres and by melting ferrous burden, which allows gas to ascend and burden to descend

The very hot gas ascends through the furnace, carrying out a number of vital functions:

- Heats up the coke in the bosh/belly area.
- Melts the iron ore in the burden, creating voidage.
- Heats up the material in the shaft zone of the furnace.
- Removes the oxygen of the iron ore burden by chemical reactions.

The hot gas travels through the blast furnace in 5–10 seconds. During this period, its composition changes through chemical reaction and its temperature decreases from 1900–2300 °C to 100–200 °C.

As a consequence of the gas movement, there are large temperature differences in the blast furnace in vertical and radial directions. A typical example of the temperature profile in the blast furnace is shown in Figure 1.6, which shows that the softening/melting zone is located in an area where temperatures are between 1200 and 1400 °C. The temperature differences in the furnace are large. In the example, the temperature gradients are larger in the horizontal direction than in the vertical direction.

Upon melting, the iron ore produces hot metal and slag, which drips down through the coke into the hearth, where it is removed by casting through the taphole.

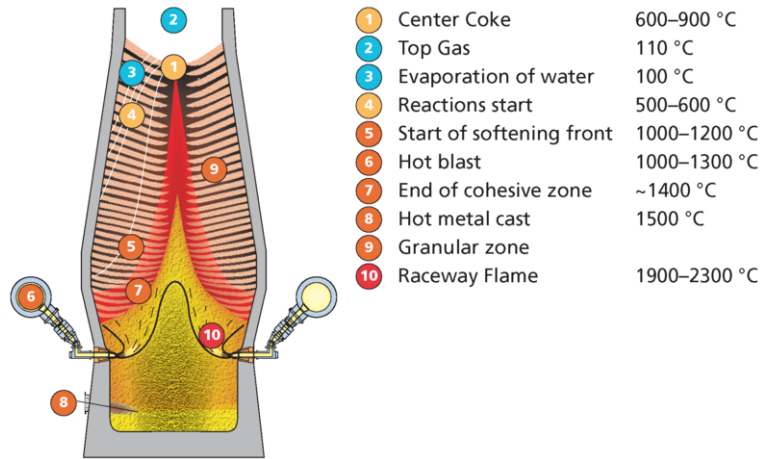

Figure 1.6 Temperature profile and various zones in a blast furnace

1.4 Equipment

1.4.1 Equipment overview

An overview of the major equipment is shown in Figure 1.7. It includes:

- Hot Blast Stoves. Air preheated to temperatures between 1000 and 1250 °C is produced in the hot blast stoves and is delivered to the furnace via a hot blast main, bustle pipe, tuyere stocks and finally through the tuyeres. The hot blast reacts with coke and injectants and forms the raceway in front of the tuyeres.
- Stock house. The burden materials and coke are delivered to a stock house. The materials are stored, screened and then weighted before final delivery into the furnace. The stock house is operated automatically. Corrections for coke moisture are generally made automatically. The burden materials and coke are brought to the top of the furnace via skip cars or via a conveyor belt, where they are discharged into the furnace in separate layers of ore and coke.
- Coal or gas auxiliary fuel is injected through the tuyeres.
- Gas cleaning. The top gas leaves the furnace via uptakes and a downcomer. The hot top gas contains many fine particles, necessitating removal of the particles and cooling the gas in a gas cleaning system consisting of a dust catcher or cyclone, wet cleaning of the gas in a scrubber and finally removing water in a demister. To save cleaning water and aid recovery of sensible heat and pressure of top gas, the dry cleaning method of blast furnace top gas has been developed and is widely used in newly built blast furnaces around the world, especially in China. The method uses a series of chambers filled with bag filters to filter fine dust in hot top gas.
- Casthouse. The liquid iron and slag collect in the hearth of the furnace, from where they are tapped via the taphole into the casthouse and to transport ladles. Depending on the size of the furnace, there may be one to four tapholes and connected casthouses. The molten slag may be quenched with water to form granulated slag, which is used for cement manufacturing.

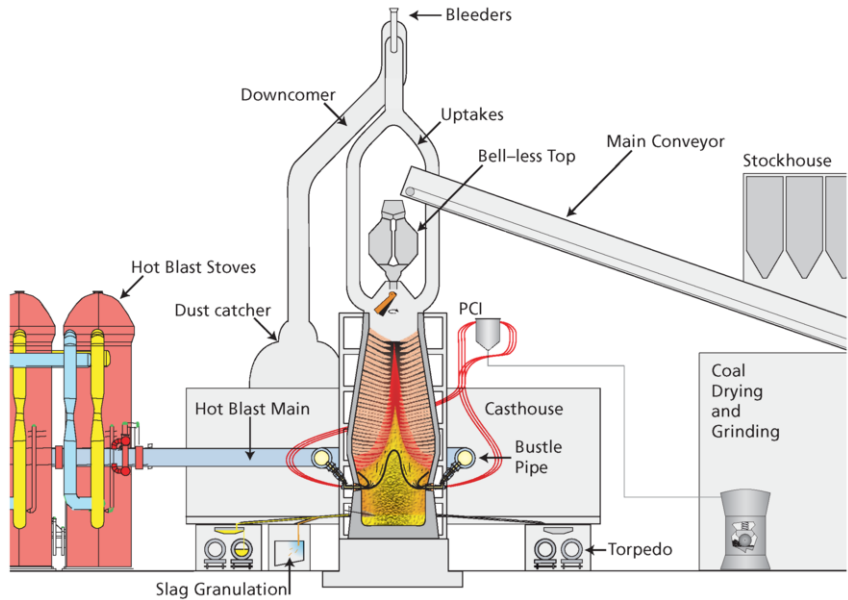

Figure 1.7 Blast furnace general arrangement

For the design of the blast furnace proper, it is important to realize that the blast furnace process can operate at a wide range of setpoints and readily get out of control. All subsystems of the furnace should be designed to be able to handle these conditions with minimal interference with the process. All subsystem requirements from the process will be costly, since production rates and coke rates can be affected, or major damage can occur. An engineer opting for a more or less forgiving design has to look seriously into the forgiving design.

The top of the blast furnace is closed, as modern blast furnaces tend to operate with high top pressure. There are various different systems to distribute the ferrous burden and coke into the blast furnace. The most common system is the bell-less top (Figure 1.8).

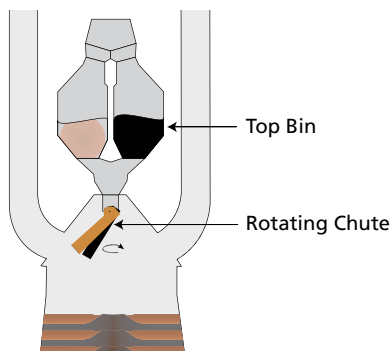

Figure 1.8 Blast furnace top charging by bell-less top

1.4.2 Blast furnace and its development

A blast furnace has the shape of two truncated cones that are joined at their widest point. The sections from the top down are:

- The throat, where the burden surface is located.
- The stack, where the ores are heated, and reduction reactions start.
- The bosh parallel or belly.
- The bosh, where the reduction is completed, and the ores are melted down.
- The hearth, where the molten material is collected and is cast via the taphole.

The liquid iron and slag are collected in the voids between coke particles in the hearth.

Blast furnaces grew considerably in size during the 20th century. In the early years of the century, blast furnaces had a hearth diameter of 4 to 5 meters and were producing around 100000 tonnes of hot metal per year, mostly from lump ore and coke. At the end of the 20th century, the biggest blast furnaces had a hearth diameter of between 14 and 15 meters and were producing 3 to 4 million tonnes per year.

The size of a blast furnace is often expressed as its hearth diameter, or as its “working volume” or “inner volume”. The working volume is the volume of the blast furnace that is available for the process i.e. the volume between the tuyeres and the burden level. Definitions of working volume and inner volume are given in Figure 1.9.

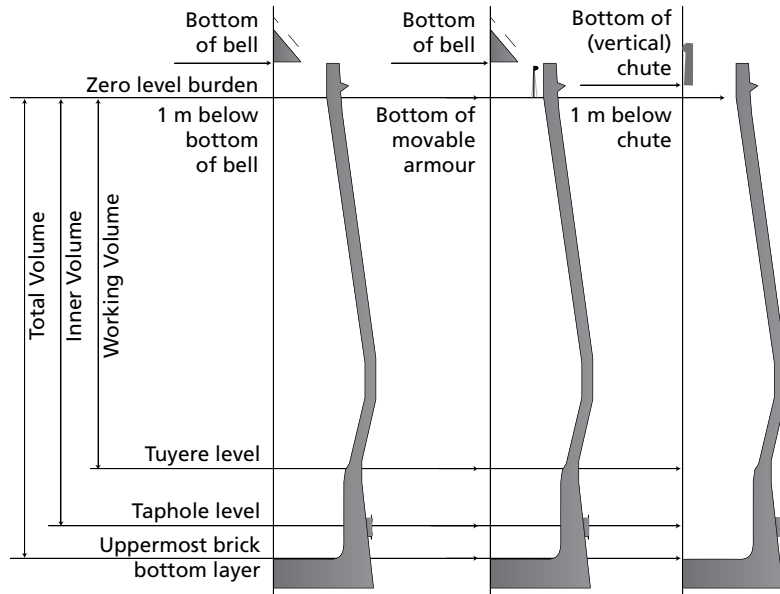

Figure 1.9 Definitions of working volume and inner volume

Very big furnaces reach hot metal production levels of more than 12000 tonnes per day. E.g. the Oita blast furnace No. 2 (Nippon Steel Corporation) has a hearth diameter of 15.6 meters and a production capacity of 13500 tonnes per day. In Europe, the Schwelgern No. 2 furnace (thyssenkrupp Steel) has a hearth diameter of 14.9 meters and a daily production of 12000 tonnes per day. In 2013 POSCO commissioned Gwangyang No. 1 blast furnace with an inner volume of 6000 m³, a hearth diameter of 16.1 meters, and a rated capacity of 5.65 million tonnes per year (-16000 tonnes per day), attaining a very high productivity of 2,9 t/m³WV/24hrs. It is the largest furnace at the moment. Currently, there are 32 blast furnaces with inner volumes above 5000 m³ in operation around the world, most of them in China.

High performance blast furnaces use mainly sinter and pellets as ferrous burden. The lump ore percentage has generally decreased to 10 to 15 % and lower. The fuel used for the process has evolved as well. The fuel represents not only energy but is also the driver of chemical reactions to reduce the oxygen content of the burden. The term reductants is used for this reason. In the early days, blast furnaces were operated with all coke operation. Nowadays, coal injection through the tuyeres is widely used. Presently, about 30 to 40 % of the earlier coke requirements have been replaced by coal injection. Occasionally, depending on the local situation, natural gas is used. As a result of new technology to access natural gas deposits, the cost of natural gas has decreased in some regions, and natural gas is now used for 10 to 15 % of the total reductant requirement. Currently the co-injection of coal and natural gas is being optimized in some areas of the world, especially in North America.

1.4.3 Cooling systems

The furnace inside is exposed to severe chemical and physical attack by raw materials and by gas at very high temperature. In order to maintain the integrity of the furnace, the inside of the shell is protected by a water-cooled refractory lining. An extensive discussion of cooling systems and specifications is outside the scope of this book.

There are two main shell cooling systems in use: stave cooling and horizontal cooling plates for the bosh of a furnace, as shown in Figure 1.10. Cooling plates are water cooled, typically produced from copper castings, with a relatively small distance between each plate location and an insert depth of 40–50 cm. If required, they can be replaced from outside in a few hours during a blast furnace stop.

Staves are vertical cooling elements, which can be made from cast iron, steel or copper, covered with refractories on the hot face. The insert depth is smaller, which leads to an increase in the working volume of a blast furnace when cooling plates are replaced by staves in the same shell. Replacing staves in an operating furnace is more difficult than cooling plate replacement and requires a furnace stop of at least a few days.

The advantage of staves is that, when the burden descends, the material can follow the wall more easily. This is an advantage, especially in the stack. The advantage of cooling plates is that they can work as an anchor for freezing a protective skull, which is difficult with staves. So, especially in the lower part of the furnace, cooling plates are more forgiving than staves. For this reason, hybrid systems are presently being developed and installed in some furnaces.

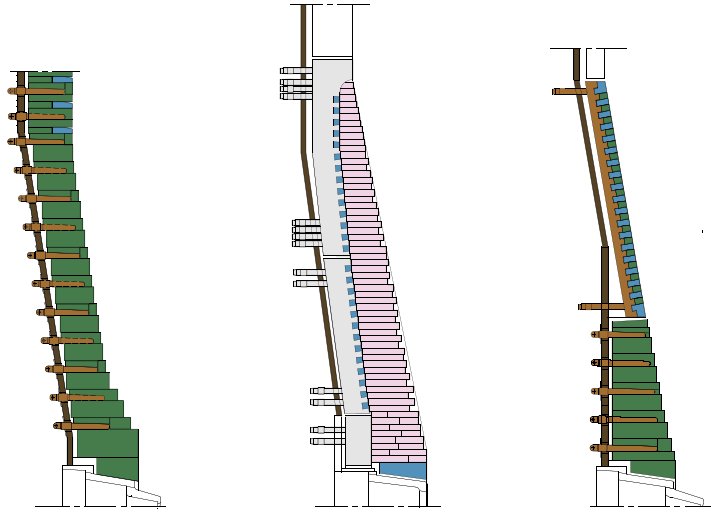

Figure 1.10 Cooling systems: plate coolers, staves and hybrid

1.4.4 Gas cleaning

The large quantity of gas produced during blast furnace operation contains 10 to 40 g/m³ of dust, which is reduced to below 10 mg/m³. Most of the dust is removed in a gravity dust catcher or a cyclone dust catcher. The gas is subsequently cleaned by either a wet cleaning process or a dry cleaning process. Wet cleaning processes have been used for many years.

A more recent development is to use dry cleaning processes with dry bag-filter cleaning (DBFC). This is used in many newly built blast furnaces, especially in China. When blast furnace gas passes through bag filters, more than 99 % of the fine dust is removed. After cleaning, the dust content of the gas is less than 5 mg/m³. The temperature of the cleaned gas is 80 to 150 °C.

The key point for operational control of a DBFC system is to keep the blast furnace gas inlet temperature in a suitable temperature range. If the temperature is too high (above 250 °C), the bag filters would be at risk of burning. If the temperature is too low (below 80 °C), condensation can occur, which jeopardizes proper gas cleaning. The advantages of dry gas cleaning are improved energy recovery from top gas and avoidance of all sludge related issues. On the other hand, handling the dry dust, which can ignite spontaneously, requires special precautions. The lower limit of the top

temperature can be a concern, since high productivity in a blast furnace can only be reached at low top temperature. In some cases, measures for the removal of chlorine compounds in dry cleaned gas have to be taken to prevent corrosion in the gas grid.

1.5 Book overview

Blast furnace ironmaking can be discussed from three different perspectives:

- The operational approach: discussing the blast furnace with its operational challenges.
- The chemical technology approach: discussing the process from the perspective of the technologist who analyzes the progress of chemical reactions and heat and mass balances.
- The mechanical engineering approach focusing on equipment.

The focus of this book is the “operator’s view”, with the aim of understanding what is going on inside the blast furnace. To this end the basic principles of the process are discussed (Chapter II) followed by the demands on burden quality (Chapter III) and coke and auxiliary reductants (Chapters IV and V). Processing the ferrous burden by gas is described in Chapter VI. The control of the process by burden distribution is discussed in Chapter VII. Subsequently, hot metal and slag quality (Chapter VIII), casthouse operation (Chapter IX), blast furnace operational control (Chapter X) and special operational situations like stops and starts, high moisture input or high amounts of fines charged into the furnace, blow-in and blow-down (Chapter XI) are discussed.

Throughout the present book practical examples are given of operating furnaces, which are indicated as Examples.

Throughout the book, examples are based on an operating “reference furnace”: a furnace with a 15 meter hearth diameter and 5000 m³ inner volume, producing 12000 tonnes of hot metal (tHM) per day, a coke rate of 300 kg/tHM and a coal injection rate of 200 kg/tHM. The details are shown in Chapter II and Annex II. Examples of operating furnaces are shown in text frames throughout the book.

II *Blast Furnace*

Process and Internal Structure

2.1 Gasifying coke and coal

The blast furnace process starts when pre-heated air, or “hot blast”, is blown into the blast furnace via the tuyeres at a temperature of up to 1250 °C. The hot blast gasifies coke (and injected coal and gas) in front of the tuyere. The gasification generates a very hot flame, which is visible through the peepsight as the “raceway”. The gas contains the heat required for melting the ferrous burden.

At the same time, oxygen in the blast is transformed into gaseous carbon monoxide (CO), and hydrogen (H₂) is generated from the injected fuels and from moisture in the hot blast. These gases can reduce the oxygen content of the burden, hence the name “reductant”.

The raceway has a banana type shape and is typically about 1.8 meters long (Figure 2.1a). The borders of the raceway are well defined at the inside and bottom, because small coke particles help create a relatively stable structure. At the side and upper part of the raceway, the coke is in continuous movement and no stable structure is formed. In Figure 2.1b on the next page the remains of the raceway are shown, after a blast furnace has been taken out of operation. It shows that every tuyere generates its own flame into the furnace.

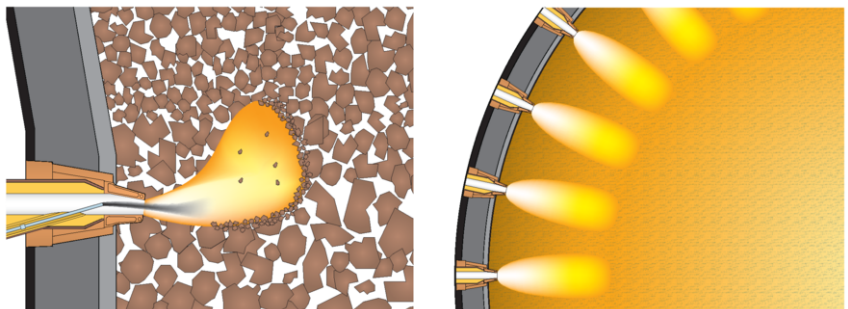

Figure 2.1a The raceway, horizontal and vertical sections



Figure 2.1b The raceway after a blowdown and nitrogen quench
(courtesy John Ricketts)

The raceway gas or bosh gas is formed as follows. For every molecule of oxygen (O_2), two molecules of carbon monoxide (CO) are formed: every cubic meter (m^3 STP) oxygen will generate $2 m^3$ STP of CO. Air contains 21 % oxygen and 79 % nitrogen. If the hot blast is enriched to an oxygen level of 27 % (and thus has 73 % nitrogen), the bosh gas will consist of 57.5 % (i.e. $73/(73+2\cdot27)$) nitrogen and 42.5 % CO gas. For the time being, we neglect the effect of hydrogen (see section 5.1). In addition, a huge amount of heat is generated in the raceway from the combustion of coke and injectants (coal, oil, natural gas). The heat leads to a high flame temperature, which generally is in the range of 1900 to 2300 °C. Since this temperature is higher than the melting temperature of iron and slag, the heat in the hot gas can be used to melt the burden. Flame temperature is discussed in more detail in Chapter VI. In the present chapter, the gas flow through the furnace is analyzed in more detail. The charge consists of alternating layers of ore burden (sinter, pellets, lump ore) and coke.

2.2 Counter-current reactor

The blast furnace is a counter-current reactor (Figure 2.2 – next page). The process starts with the hot blast through the tuyeres, which reacts with the coke and coal or natural gas injection in the raceway (Figure 2.1) generating hot raceway gas (1900–2300 °C). The hot raceway gas moves upwards, while heating and melting the charged materials. Consumption of coke and melting of the ore burden creates voidage inside the furnace, which is filled with descending burden and coke. The upward movement of gas: gas passes through a blast furnace in 5–10 seconds, while towards the burden stockline (21 to 25 m from tuyeres) the gas temperature drops from a flame temperature at the tuyeres of 1900–2300 °C to a top gas temperature of 100–150 °C. The downward movement of the burden: burden is charged cold and wet into the top of the furnace; it is reduced, melted and heated to 1500 °C in 5–8 hrs.

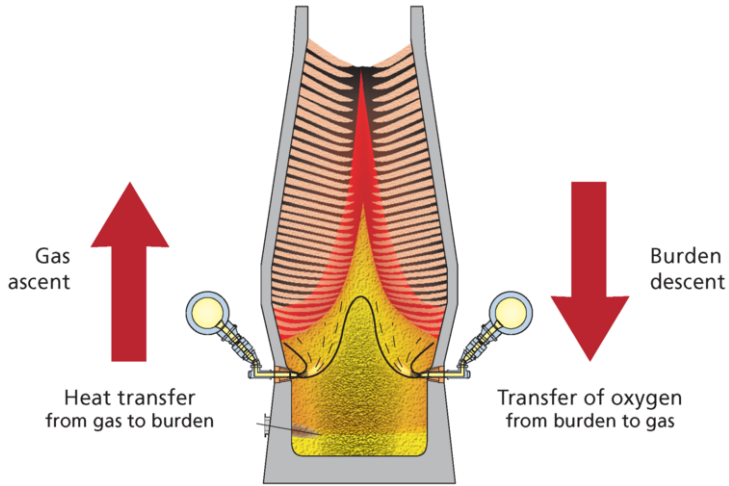

Figure 2.2 The blast furnace as a counter-current reactor

2.3 Internal layer structure

The internal layer structure of alternating coke and ferrous burden layer is maintained throughout the furnace until the burden is molten. In the cohesive zone the burden materials soften and collapse. Upon further heating, the burden melts and drips down through the active coke zone and collects in the hearth that is filled with coke and separates into hot metal and slag. Coke remains solid in the blast furnace. It is consumed by gasification at the tuyeres, chemical reactions in the furnace and by dissolving in hot metal.

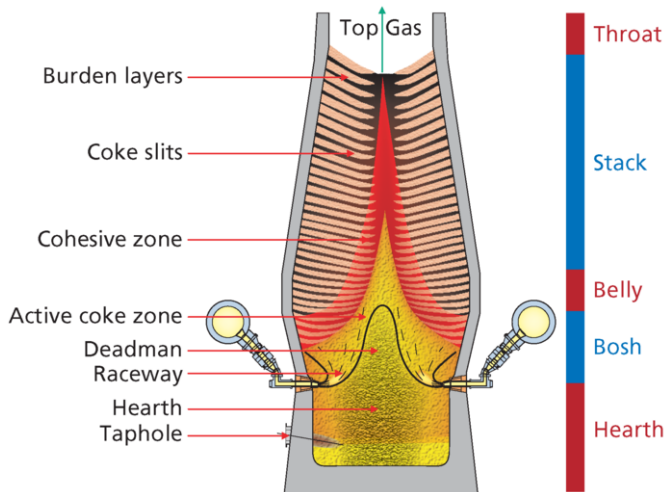

Figure 2.3 Blast furnace zones

As indicated in Figure 2.3, an operating blast furnace contains:

- Layers of ore and coke.
- An area where ore starts to soften and melt, known as the softening–melting zone or cohesive zone.
- An area where there is only coke and liquid iron and slag, called the “active coke” or dripping zone.
- The deadman or “inactive coke zone”, which is a stable pile of coke in the hearth and extending into the bosh of the furnace.

The internal structure was derived from studies of quenched furnaces, which are “frozen in action” using water or nitrogen. The examples in Figure 2.4a clearly show the layer structure of coke and ore. Figure 2.4b shows a solidified cohesive zone. Further analysis reveals information about the heating and melting of the ore, as well as of the progress of chemical reactions.

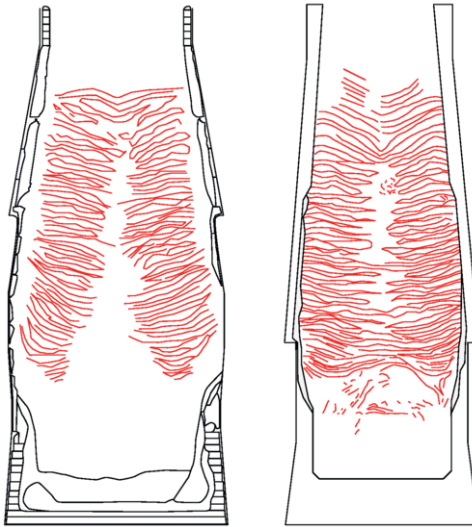

Figure 2.4a Dissections of quenched blast furnaces Kakogawa 1 and Tsurumi
(Based on Omori et al, 1987)



Figure 2.4b Cohesive zone left after blow–down

Example 2.1 Furnace profile and burden and coke layers

The profile of the reference furnace is shown in Figure 2.5. For the furnace, the throat diameter is 11 meters, the hearth diameter 15 meters. As a consequence, the cylinder from throat to hearth is located 2 meters from the tuyeres, as indicated by the blue cylinder.

This cylinder represents about 50 % of the total working volume of the furnace. This means that coke and ferrous burden move not only downwards, but also sideways. The blue cylinder is located at the end of the raceway. The diameter at the belly is 16.5 meters, which has a surface of 2.3 times the surface at the throat. The average layer thickness at the belly is approximately 43 % of the thickness at the throat.

In the reference furnace, the coke layer decreases from 57 cm at the throat to 25 cm in the belly, which is 5–6 coke lumps. The ferrous layer decreases from 78 cm to 35 cm, where layer thickness decreases further by softening.

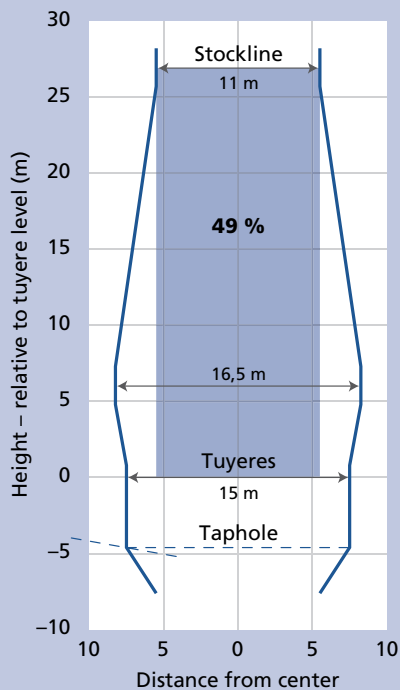

Figure 2.5 Dimensions of the reference blast furnace used throughout the book. The highlighted cylinder represents the volume directly below the throat, corresponding to 49 % of the volume.

2.4 How gas flows through the furnace

The hot gas ascends through the ore and coke layers to the top of the furnace. If there was only coke in the blast furnace, the chemical composition of the gas would remain constant, but the temperature of the gas would reduce as it comes into contact with the colder coke layers high in the furnace. The gas flowing through a blast furnace filled with coke is shown in Figure 2.6. To the experienced blast furnace operator, the furnace filled with only coke may seem a theoretical concept. However, in some practical situations, like the blow-in of a new furnace or when taking a furnace out of operation for a long time (banking) the furnace is almost entirely filled with coke.

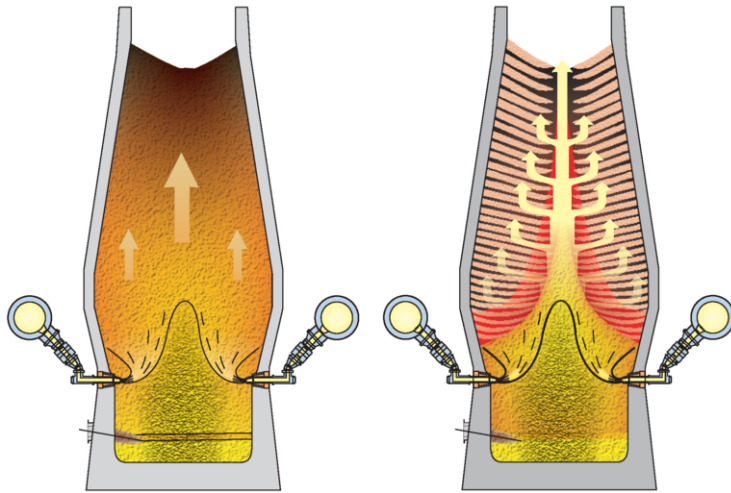

Figure 2.6 Gas flow in a furnace filled with coke only (left) and in a furnace filled with alternating layers of coke and ore (right).

In the normal operational situation, the furnace is filled with alternating coke and ore layers. About 30 to 45 layers of ore separate the coke into layers. It is important to note that the permeability of coke is much better than the permeability of ore. This is due to the fact that coke is much coarser than sinter and pellets, and the void fraction within the coke layer is higher. Consequently, the burden layers determine how the gas flows through the furnace, while the coke layers function as gas distributors.

If gas flows from the bosh upwards, what happens to the gas as it gradually cools down? Firstly, the heat at a temperature in excess of 1400 °C, which is above melting temperature of hot metal and slag, is transferred to the layered burden and coke. This melts and heats up the metallic portion. In the temperature range from 1200 °C to 1400 °C, the burden will soften and stick together rather than melt. Below the softening and melting zone the remaining oxygen in the ore burden is removed.

Upon further cooling, the gas is capable of removing oxygen from the ore burden, while producing carbon dioxide (CO_2). The more oxygen that is removed, the more efficient the furnace is. Below temperatures of $1000\text{ }^\circ\text{C}$ the following takes place:

- Heat is transferred from the gas to the burden.
- CO_2 gas is generated from CO gas, while reducing the amount of oxygen of the ore burden. This is called the gas reduction reaction, and in the literature is sometimes called “indirect reduction” as opposed to “direct reduction”. No additional gas is generated during this reaction.
- A similar reaction takes place with hydrogen. Hydrogen can remove oxygen from the burden to form water (H_2O).

Higher in the furnace, the moisture in the burden and coke is vaporized in the “drying zone” and so is eliminated from the burden before any chemical reactions take place.

In summary:

- Heat is transferred from the gas to the ore burden, which melts and softens (above $1200\text{ }^\circ\text{C}$).
- Residual oxygen in the burden is removed and additional CO is generated. This is known as the direct reduction reaction.
- Heat of gas ($< 1000\text{ }^\circ\text{C}$) is transferred to ore burden and coke. CO in the gas removes oxygen from the burden, and generates CO_2 , this is called gas reduction or indirect reduction.

2.5 Processing the ferrous burden

Burden and coke are gradually heated up on their way down the stack, and moisture is evaporated. At around $500\text{ }^\circ\text{C}$, the removal of oxygen begins. Figure 2.7 shows a simplified diagram of the removal of oxygen from the ore burden.

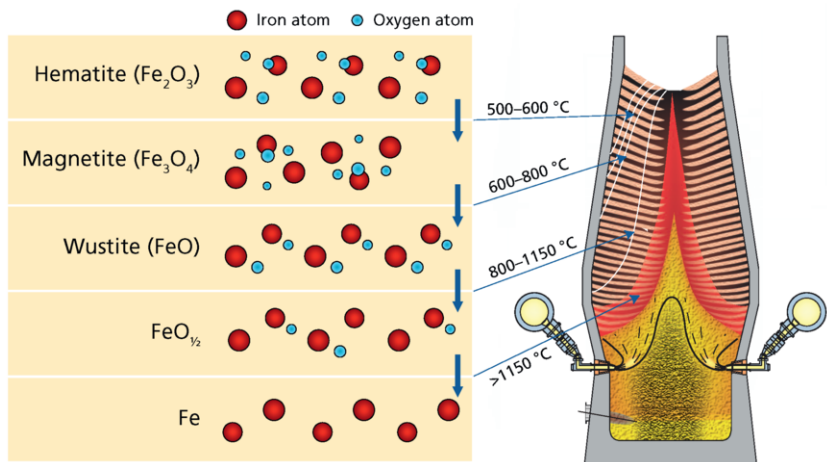

Figure 2.7 Schematic presentation of reduction of iron oxides and temperature

The first step is the reduction of hematite (Fe_2O_3) to magnetite (Fe_3O_4). The reduction reaction generates energy, so it helps to increase the temperature of the burden. In addition, the reduction reaction creates tension in the crystal structure of the burden material, which may cause the crystal structure to break into smaller particles. This property is called Low Temperature Disintegration (LTD). Several tests are available to quantify the effects (see Chapter III).

The second step in reduction is magnetite (Fe_3O_4) to wustite (FeO). This reduction reaction costs energy.

Further down in the furnace the temperature of the burden increases gradually, and part of the iron oxides are reduced to metallic iron until the burden starts to soften and to melt in the cohesive zone. The molten iron and slag drip through the coke layer below the cohesive zone and are collected in the hearth.

We now consider the interaction between the gas and the ore burden. The more the gas removes oxygen from the ore burden, the more efficient the blast furnace process. Consequently, intimate contact between the gas and the ore burden is very important. To optimize this contact the permeability of the ore burden must be as high as possible. The ratio of the gas flowing through the ore burden and the amount of oxygen to be removed from the burden must also be in balance.

Experience has shown that many problems in blast furnaces are the consequence of low permeability ore layers. The permeability of an ore layer is largely determined by the quantity of fines (under 5 mm) in the layer. Generally, the majority of the fines are generated by sinter, or come from lump ores. The problem with fines in the furnace is that they tend to concentrate in rings in the furnace. As fines are charged to the furnace they concentrate at the point of impact where the burden is charged. They are also generated by low temperature reduction–disintegration. So, it is important to screen the burden materials well, normally with 5 or 6 mm screens in the stock house, and to control the low temperature reduction–disintegration characteristics of the burden.

2.6 Furnace efficiency

The process efficiency of the blast furnace, generally considered to be the reductant (coke plus injectants containing carbon) rate per tonne of hot metal, is continuously monitored through measurement of the chemical composition of the gas exiting the furnace top, known as “top gas”. The efficiency is expressed as the gas utilization formula, which indicates the percentage of CO gas that is utilized for reduction of the ferrous burden.

$$\eta_{\text{co}} = \frac{\text{CO}_2}{\text{CO} + \text{CO}_2} \times 100 \%$$

In addition, in modern furnaces the gas composition over the radius is frequently measured. The latter shows whether or not there is a good balance between the amount of reduction gas and the amount of ore in the burden across the radius. The wall zone is especially important, as the coke percentage in the wall area should not be too low. The wall area is the most difficult area for melting the burden, because the gas at the wall loses much of its temperature by heat loss to the cooling system.

The top gas analysis gives a reasonably accurate indication of the efficiency of the furnace. When comparing different furnaces, one should realize that hydrogen also takes part in the reduction process.

The gas utilization also depends on the amount of oxygen that must be removed. Since pellets have about 1.5 atoms of oxygen per atom of Fe (Fe_2O_3) and sinter has about 1.45 (mix of Fe_2O_3 and Fe_3O_4), the top gas utilization will be lower when using sinter. It can be calculated as about 2.5 % difference of the top gas utilization, when comparing an all-pellet burden with an all-sinter burden.

2.7 Casting hot metal and slag

The liquid hot metal and slag have to be removed from the furnace. This is done by making a hole (a taphole) of 40–60 mm diameter and length of 2,5–3,5 m in the furnace. Hot metal and slag separate in two liquid phases. The hot metal is more dense ($\sim 7,2 \text{ tonne/m}^3$) than slag ($\sim 2,3 \text{ tonne/m}^3$). As a consequence, generally the hot metal comes out of the taphole first, and later hot metal and slag are drained together. Finally, when the slag level is below the taphole elevation, some of the gas generated in the raceway blows out of the taphole indicating the end of the cast. An operator should be aware that the volumes of slag and iron are quite similar: the hot metal volume and slag volume produced are about equal at a slag volume of 320 kg/tHM. At higher slag rates, there is a higher volume of slag to be cast than hot metal. Moreover, since slag is more viscous and also more variable than hot metal, it is more difficult to remove from the furnace than hot metal.

Example 2.2 Contents of and gas flow through a blast furnace

The contents of a blast furnace and the gas flow can be derived from operational results. How long does it take to process burden and gas? Throughout this book a consistent set of calculation examples with the same starting points is used. The reference furnace has an inner volume of 5000 m³ and a 15 meter hearth diameter. A schematic drawing is shown in Figure 2.5. The furnace has a daily production of 12000 tonnes of hot metal (tHM) at a coke rate of 300 kg/tHM and a coal injection rate of 200 kg/t. Yield losses are neglected. The content can be calculated as below. Additional data are given in Table 2.1 and Annex II.

			Bulk Density kg/m ³	Weight percentage		
				Fe	C	H
Ferrous Charge	kg/tHM	1570	1800	60.2		
Coke	kg/tHM	300	550		86.0	
Coal	kg/tHM	200			80.0	4.4
Blast volume	m ³ STP/min	7500				
Oxygen	%	27				
Hot metal production	tHM/d	12000	94.5	4.5		
Inner volume	m ³	5000				
Working volume	m ³	4250				
Throat diameter	m	11.0				
Hearth diameter	m	15.0				
One charge contains	tHM	85				
	t burden	133.5				
	t coke	25.5				
	m ³	0				
Layer burden at throat	m	0.78				
Layer coke at throat	m	0.57				
Voidage in shaft	%	30				

Table 2.1 Data for calculation of blast furnace contents

How much blast oxygen is used per tonne hot metal?

The oxygen from hot blast comes to 243 m³ STP blast oxygen/tHM as shown in Table 2.2. This is calculated as $27/100 \cdot 7500 \cdot 60 \cdot 24/12000$.

Oxygen	%	27
Wind volume	m ³ STP/min	7500
Production	tHM/d	12000
Oxygen use	m ³ STP/tHM	243

Table 2.2 Oxygen use in reference furnace

In how many hours is the ferrous burden processed?

To produce one tonne of hot metal, the furnace is charged with 300 kg coke ($300/550 = 0.55 \text{ m}^3$) and 1.570 kg sinter/pellets ($1570/1800 = 0.87 \text{ m}^3$). In total, 1.42 m^3 of material is charged per tonne of hot metal. This is put through a furnace with a working volume of 4250 m^3 . The burden is processed in 5.68 hrs. The estimation is shown in Table 2.3, taking into account a typical compression of 10 %. Processing will be faster towards the center and slower in the wall area.

Coke	kg/tHM	300	m^3	0.55
Ferrous charge	kg/tHM	1570	m^3	0.87
Tonne hot metal			m^3	1.42
Hot metal production	tHM/d	12000		
Coke charge	t/d	3600	m^3/d	6545
Ferrous charge	t/d	18840	m^3/d	10467
Total			m^3/d	17012
Compression	%	10	m^3/d	15311
Working volume	m^3	4250		
Minus 1 m at throat	m^3	-95		
Minus 3 m active coke zone	m^3	-530		
Available	m^3	3625		
Processed	m^3/d	15311	m^3/h	638
In available volume			m^3	3625
Processing time			h	5.68

Table 2.3 Ferrous burden processing time

How many charges are present above the active coke zone?

A charge consists of a layer of ore and coke. The number of charges depends on the weight of one layer and coke rate. In the reference furnace a layer contains 134 tonnes of ferrous burden, corresponding to 85 tonnes of hot metal. The number of charges is 33, as calculated in Table 2.4, where 10 % compression is considered.

Available volume	m^3	3625
Volume per tonne hot metal	m^3/tHM	1.42
In available volume	tHM	2557
Tonne hot metal per charge	tHM	85
Number of charges		30
Compression	%	10
Charges considering compression		33

Table 2.4 Number of charges in the reference furnace

Time required for the gas to travel through the furnace

The blast volume is 7500 m³ STP/min with 27 % oxygen. For every m³ of oxygen, two m³ of CO are produced. This gas has a high temperature, the furnace is operated at a high pressure, and extra gas is formed by the direct reduction reaction. It contains hydrogen as well. If all these effects are neglected, the exercise is straightforward: Suppose the void fraction in the burden is 30 %, then the open volume in the furnace is the working volume times voidage (4250 m³, voidage 30 %). Through this volume more than 7500 m³ STP gas is blown per minute. So the residence time of the gas is approximately 10 seconds: $(4250 \cdot 0.3) / (7500/60)$. This is a crude estimate.

It is possible to make the corrections for temperature, pressure, additional CO from direct reduction and hydrogen from coal. Assume an average temperature of the gas of 900 °C and an average pressure of 3.2 bar. The estimation shown in Table 2.5 results in 6.3 seconds for the reference furnace. Note that the gas velocity above the stockline is an average of only approximately 1 m/s. However, in the center the gas speed maybe 10 times the average. In general, as soon as the hot blast has entered through the tuyeres, gas velocities drop down to low or very low values.

Blast volume	m ³ STP/min	7500
Oxygen	%	27
Bosh gas (H ₂ neglected)	m ³ STP/min	9525
Gas from direct reduction		
Carbon used for DR	kg/tHM	96
Hydrogen from coal	kg/tHM	8.8
Extra gas	m ³ STP/tHM	278
Total	m ³ STP/min	2315
Total gas volume	m ³ STP/min	11840
Gas volume in m ³		
Higher temperature (est.)	°C	900
Blast pressure	bar	4.3
Top pressure	bar	2.5
Pressure inside (est.)	bar	3.2
Real gas volume	m ³ /min	12112
Flows through		
Working volume	m ³	4250
Voidage	%	30
Available volume	m ³	1275
Time in furnace	min	0.105
	sec	6.3

Table 2.5 Time gas is in the furnace

III *The Ferrous Burden*

3.1 Introduction

In the early days of commercial ironmaking, blast furnaces were often located close to iron ore mines. In those days, blast furnaces were using local ore and charcoal, later replaced by coke. In most of the industrial areas of the time, the 19th century, there were many blast furnaces operating in Germany, Great Britain and the United States. After the application of the steam engine for ships and transportation, the center of industrial activity moved from the ore bodies to the major rivers, such as the river Rhine, and later from the rivers to the coastal ports with deep sea harbors. This trend, supported by seaborne trade of higher quality ores may appear clear at present, but has only a recent history. In 1960 there were sixty operating blast furnaces in Belgium and Luxembourg. Since 2009, only two have been operating; both have a favorable coastal location. A similar trend, with a much faster pace can now be observed in China.

The trend towards fewer but larger furnaces has increasingly made a rich iron burden a requirement. A rich iron burden translates into a high Fe content, frequently obtained after a physical beneficiation or enrichment process of the ore at the mine. This has consequently made more fine material available, as opposed to a rich and good lump ore, which in turn has become more scarce. These fine ores are too impermeable to gas flow to be charged directly to the blast furnace. Hence sintering and pelletizing as an agglomeration process is favored. Sinter and pellets are used in combination with lump ore as the ore burden. Briquetting of in-plant revert materials is an option, as recycling of some of these waste materials through a sinter plant becomes more restricted or, in the absence of a sinter plant, a prerequisite. Boosting blast furnace productivity through charging of metallic iron (scrap, DRI or HBI) in combination with reducing greenhouse gas emissions can make up the total ferrous burden

A well prepared blast furnace burden consists, for the major part, of sinter and/or pellets and can be topped off with sized lump ore (Figure 3.1). Sinter burdens are prevalent in Europe and Asia, while pellet only burdens are used more commonly in North America and Scandinavia. In China, ferrous burden now consists of an estimated 70 % sinter, 15–20 % pellets and 10–15 % lump. Many other companies use sinter as well as pellets, although the ratios vary widely.



Figure 3.1 Burden materials

Most mines generate fines only or have a lump yield below 30 %, with a few exceptions (South Africa, Canada) reporting over 70 % yield. Lump being a natural agglomerate, its properties are harder to control and it can have a large effect on the blast furnace process. For this reason, it is mainly used as a lower cost replacement for acid pellets. For high productivity, low coke rate blast furnace operations, lump ore is generally maximized in the range of 10 to 15 %. The achievable rate depends on lump ore quality and its proper use. Hence the successful use of higher percentages is documented. The present chapter deals with the ferrous burden quality.

3.2 Iron ore

Iron is the fourth most abundant element in the earth's crust, making up approximately 5 % of the total. However, mining of iron (as an oxide) is only economically viable where substantial concentration has occurred, and only then can it be referred to as iron ore. More than 3 billion years ago, through the generation of Banded Iron Formation, the first concentration occurred.

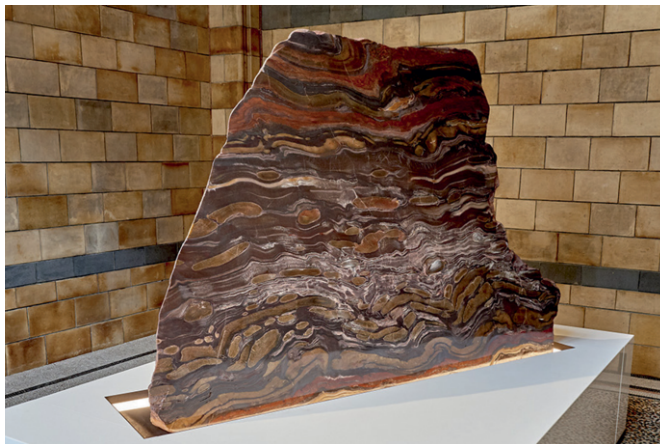

Figure 3.2 Banded Iron Formation (Natural History Museum, courtesy Rio Tinto)

The conventional concept is that several billion years ago, the banded iron layers were formed at the bottom of ancient shallow seas, as the result of an increase in oxygen in the water. These formed insoluble iron oxides that precipitated out of the water, alternating with mud, later forming cherts and silicate layers. Subsequently, metamorphoses or leaching out of the cherts and silicates resulted in a concentration of the iron oxide. Through further geological processes such as (de)hydration, inversion leaching, deformation and sedimentation, a wide variety of iron ore deposits were created all around the world. These total over 300 billion tonnes at an average Fe content of 47 %.

A minor fraction of these deposits is currently commercially mined as iron ore with Fe contents ranging from below 30 % to up to 68 % (pure iron oxide as hematite, Fe_2O_3 , contains 70 % Fe). As mentioned before, an efficient blast furnace process requires a rich Fe burden, preferably in excess of 58 % Fe. With the conventional mining process of drilling, blasting and crushing, a wide size range of particles is obtained. Through screening, lump ore and sinter fines are separated. However, an increasing proportion of the iron ore needs further beneficiation and processing prior to becoming a usable material for the blast furnace. A vast amount of equipment has been developed to upgrade the iron ore to a suitable product economically. These processes will not be described here, but most of them are based on liberating the iron oxide from the gangue minerals and then making use of the differences in density, magnetic properties or surface properties between the minerals to separate them physically. Sometimes large amounts of quartz (SiO_2) need to be removed, and desliming of undesirable clay, or minor amounts of impurities (such as phosphorus in the mineral apatite) is carried out. Depending on the specific requirements, these processes can be easily achieved, or they can be difficult or even impossible.

These processes result in a wide variety of beneficiated iron ores with varying grades, impurities and sizes being available on the market. Silica content can vary from 0.6 % to above 10 %, and phosphorus from below 0.005 % to above 1 %. Similar variations apply for other components such as the oxides of aluminum, calcium, magnesium, manganese, titanium and alkalis. With tighter environmental control over the whole process chain, tramp elements at minute levels are starting to play a more dominant role. From sulfur, zinc and copper to mercury, arsenic and vanadium. The importance of each of these elements greatly depends on the applied process and process conditions, environmental measures and locally applicable legislation.

Due to the physical beneficiation, more and finer iron ores have been generated. Though the designation is not consistent, the ore in the size range for sintering (indicative between 6 mm and 150 μm) is called sinter feed, while smaller and more narrow sized is denoted concentrate, and finally there is pellet feed which is indicative < 150 μm (90 % minus 200 mesh) and suitable mainly for pelletizing. The original lump ore is typically between 8 mm and 40 mm. Most common ferrous ores are hematite (Fe_2O_3), magnetite (Fe_3O_4) and goethite ($\text{Fe}_2\text{O}_3 \cdot x\text{H}_2\text{O}$).

3.3 Quality demands for the blast furnace burden

The demands for the blast furnace burden extend to the chemical composition and the physical durability of the burden materials. The chemical composition must be such that after the reduction and melting processes the desired iron and slag compositions are produced. This will be determined by the chemical composition of all the materials charged in the furnace. The physical and metallurgical aspects of the quality demands are related to the properties in both the cold and the hot state and to assure that the gas can flow through the burden and react with the ferrous components. Both aspects are discussed in depth in this chapter.

3.3.1 Generation of fines, reducibility, softening and melting

In the shaft zone of the blast furnace, the permeability of the burden is determined by the sizing of the burden components and specifically the amount of fines (see Figure 3.3). Fines may be defined as the fraction of the material less than 5 mm, since the burden components have a general range of 5 to 25 mm. If there are too many fines and especially fines below 5 mm, the void fraction will decrease and the resistance for gas will increase (Hartig et al, 2000). There are two sources for fines, those that are directly charged into the furnace, and those that are generated in the shaft by the process.

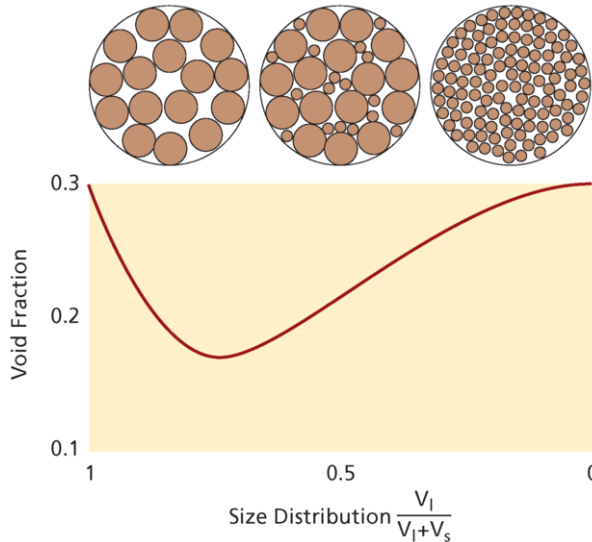

Figure 3.3 Permeability for gas flow depends on void fraction, which depends on the ratio of smaller and larger particles. Example of two types of spherical particles, large (V_l) and small (V_s). The x-axis gives the fraction of the large particles: $V_l/(V_l+V_s)$. The ratio V_l/V_s itself strongly influences the absolute void fraction. This example assumes a high ratio between two sizes of particles; in reality a size range will always exist.

Fines before charging can be controlled by proper screening in the stockhouse, just before charging to the blast furnace. The target should be less than 3 % below 5 mm, after screening in the stockhouse. Measurement of the percentage of fines after screening in the stockhouse can give an indication whether or not excessive fines are charged into the furnace. Material from the stockyard will have varying levels of fines and moisture, and thus screening efficiency will be affected accordingly. In some cases, iron ore is pre-screened in the stockyard to remove fines that cannot be removed effectively in the stockhouse, like piggy-back fines.

- Once in the furnace, during the first reduction step from hematite to magnetite, the structure of the burden materials breaks down, and fines are generated. Sinter and lump ore are especially prone to this effect, known as reduction-disintegration or reduction-degradation. The reduction-disintegration depends on the strength of the bonds between the particles of ore fines in sinter and lump ore. Generally speaking, the reduction-disintegration is dependent on:
- The FeO percentage, especially in the sinter. The more magnetite (Fe_3O_4 , which corresponds to $\text{FeO}\cdot\text{Fe}_2\text{O}_3$) is present, the stronger the sinter and the less reduction-disintegration can take place at low temperature, caused by the change in crystal structure from hematite to magnetite. In the sinter process, the FeO percentage in the sinter can be increased by cooling sinter with air that is low in oxygen or increased by adding more fuel (coke breeze) to the sinter blend.
 - The chemical and mineralogical composition of the lump ore and sinter. For sinter, basicity, Al_2O_3 and MgO content play an important role. Higher basicity improves sinter strength while higher alumina and magnesia can have a negative impact on sinter strength. Lump ore strength is dictated by mineralogy in combination with compactness/porosity.
 - The heating and reduction rate in the furnace. The slower the progress of heating and reduction, the more time is given for disintegration of sinter and lump ore.
 - The amount of hydrogen in the reducing gas. More hydrogen in the reducing gas leads to lower reduction-disintegration.

A major requirement for the blast furnace ore burden is to limit the quantity of fines within the furnace to as low as possible. This can be achieved by:

- Proper screening of burden materials before charging. Screens with 5 mm aperture are normal operational practice. Dry sinter and pellets screen more efficiently than wet pellets, lump and stocked sinter from the yard.
- Good reduction-disintegration properties.

During charging, fines in the burden material tend to concentrate at the point of impact on the burden surface. The level of reduction-disintegration increases in areas where the material is heated and reduced slowly. A charged ring of burden with a high concentration of fines will impede gas flow, experience the slower warm-up and so result in a higher level of reduction-disintegration. Hence this negative process sustains itself.

The reducibility of the burden is controlled by the contact between gas and the burden particles as a whole, as well as the gas diffusion into the particles. Whether or not good reduction is obtained in the blast furnace is governed by the layer structure of the burden and the permeability of the layers, which determines the blast furnace internal gas flow. The intrinsic reducibility of the burden components will be of less importance, since reduction to wustite takes the same time for materials with different reducibility. See operational results in Example 2.

As soon as burden material starts softening and melting, the permeability for gas is greatly reduced. For this reason, the burden materials should start melting at relatively high temperatures, and the difference between softening and melting temperatures should be as narrow as possible, so that they do not impede gas flow while they are still high up in the stack. Furthermore, the amount of slag is also important for furnace permeability. Melting properties of burden materials are determined by the slag composition. Melting of acid pellets and some lump ore can start at temperatures as low as 1000 to 1100 °C, while fluxed pellets and basic sinter generally starts melting at higher temperatures. See also Section 8.7 on how iron ore melts.

3.3.2 Ore burden quality tests

Ore burden material is characterized by the following.

- Chemical composition.
- Physical characteristics:
 - Size distribution, which is important for the permeability of ore burden layers in the furnace.
 - Cold strength, which is used to characterize the degradation of ore burden materials during transport and handling.
- Metallurgical properties:
 - Reduction–disintegration, which characterizes the effect of the first reduction step and is relevant in the stack zone of the furnace.
 - Reducibility, which characterizes the capability for the material to improve the extent of reduction reactions.
 - Softening and melting properties, which are important for the formation of the cohesive and melting zone in the furnace.

Most of the tests are ISO standardized; some of the tests are generic for sinter, pellets and lump but some are specific. For pellets for example, a cold compression strength and a swelling test are applicable. The latter is to ensure that the volume increase during reduction does not exceed a set maximum. Specifically, lump ores are tested for decrepitation: fracturing of the lump due to thermal decomposition of crystalline water during the initial stage of heating in the top of the blast furnace.

Table 3.1 summarizes these characteristics with an indicative range. The authors consider the ranges suitable for high performance blast furnace operation,

which is a productivity above 2,4 tHM per m³ inner volume per 24 hours and a coke rate below 300 kg/tHM.

A short description of generic tests used for characterization of materials is given below with the objective being to understand the terminology.

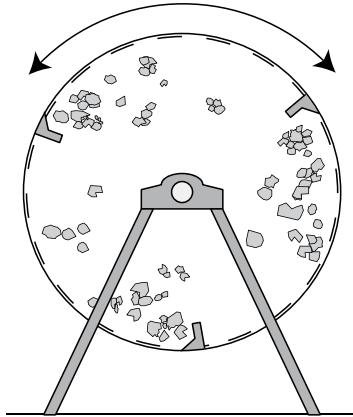

Figure 3.4 Principle of tumble test

	What is measured?	Results	Optimum Range		Reference
			Sinter	Pellets	
Mean Size	Size distribution	Average size, mm % 6.3–16 mm % < 0.5 mm	< 2 %	> 95 % < 2 %	ISO 4701
Cold Strength	Size distribution after tumbling Compression	% > 6.3 mm % < 0.5 mm daN/p	> 70 %	> 90 % < 5 % > 150	ISO 3271 ISO 4700
Strength after reduction LTD (Low Temp. Disintegration)	Size distribution after reduction and tumbling	% > 6.3 mm % < 3.15 mm % < 0.5 mm	< 20 %	> 80 % < 10 %	ISO 4696
Reducibility	Weight decrease during reduction	%/min	> 0.7 %	> 0.5 %	ISO 4695

Table 3.1 Characterization of ore burden, indicated range is suitable for high performance blast furnace operation.

3.3.2.1 Tests for cold strength

Cold strength is mostly characterized by a tumbler test. For this test an amount of material is tumbled in a rotating drum for a specified time interval. Afterwards the amount of fines is measured. The size distribution after tumbling is determined and used as a quality indicator (Figure 3.4). This process simulates the physical transport and handling of all ferrous burden components. Pellets are also tested for Cold Compression Strength to simulate the weight of the burden on the pellets inside the furnace and amount of breaking under a load.

3.3.2.2 Tests for reduction–disintegration

The reduction–disintegration tests are carried out by heating a sample of the burden to at least 500 °C and reducing the sample with gas containing CO (and sometimes H₂). After the test, the sample is cooled, tumbled and the amount of fines is measured. The quoted result is the percentage of particles smaller than 3.15 mm. Since pellets generate a minimum of fines, sometimes a dynamic test is used to better distinguish the difference between pellet qualities. In this case the pellets are reduced while being tumbled in a small rotating retort.

3.3.2.3 Reducibility

Reducibility is measured with two different ISO tests in a gas containing CO, at a temperature of 900 °C or 950 °C. During the test period, the weight of the sample is continuously measured. The weight loss is contributed to oxygen loss, and either a figure for reducibility (dO/dt) or final reduction degree after 180 minutes is obtained.

Sometimes, non–ISO standardized tests are applied with generally the aim to simulate the actual blast furnace conditions. HOSIM is such an example of a blast furnace simulation test where the sample is reduced to the endpoint of gas–reduction in a furnace. After the test, the sample is then tumbled. The results are the reducibility, defined by the time required to reduce the sample to the endpoint of gas reduction. The reduction–disintegration is represented by the percentage of fines (under 3.15 mm) after tumbling.

Although all these tests are relevant for the upper part of the blast furnace process, the ISO tests are excellent for having an idea on burden quality, comparing qualities or controlling shipment to shipment quality. The more advanced simulation tests provide a more realistic description of the effects of that burden in the blast furnace. If test conditions are continued to higher temperatures and the direct reduction (i.e. simulation of the lower part of the furnace) is included, tests are referred to as softening and/or melting tests. Pressure drop over the ferrous burden sample, softening and melting trajectories and amount of material dripped out of the sample characterizes the burden. Examples of softening tests are RUL (Reduction Under Load) and tests including melting are for example REAS (Reduktion, Erweichung, AbSchmelzen), ASAM (Advanced Softening And Melting) and multiple other non–standardized softening and melting tests developed in–house.

3.4 Sinter

Sinter plants are almost always located in the vicinity of the blast furnace to process a mixture of different iron ore fines, recycled ironmaking products and fluxes into sinter. With the aid of solid fuel (coke breeze/anthracite), the aim is to obtain a sinter with suitable burden characteristics (chemical, physical, and metallurgical). This is achieved by a correct combination of the nature and

composition of each component of the mixture and the sinter process conditions applied. Sinter characterization not only includes chemical and granulometric analysis, with sometimes determination of the mineral phases in its structure, but also assessing a series of quality indices that include cold strength, low temperature degradation and reducibility. Within these constraints, sinter plants will be operated at their maximum productivity, as it generally is the lowest cost agglomerate.

3.4.1 Sinter quality

Sinter is made in three different types: acid (CaO/SiO_2 ratio below 1.0), fluxed (CaO/SiO_2 ratio between 1.0 and 2.5) and super-fluxed sinter (CaO/SiO_2 ratio above 2.5) sinter. Fluxed sinter is the most common type. Since sinter properties vary considerably with the blend type and chemical composition, only some qualitative remarks can be made.

The sinter quality is defined by:

- Size distribution: sinter size ranges from 5 mm to 40 mm with a mean size ranging from 15 to 25 mm as measured after the sinter plant. The more basic the sinter, the smaller the average size. Sinter degrades during transport and handling, so sinter has to be re-screened at the blast furnaces to remove the generated fines. Sinter from stockyard may have different properties from freshly produced sinter directly from the sinter plant. If stock sinter must be used in the blast furnace, it should be charged in a controlled fashion, and diluted with as much fresh sinter as is possible, such as by using a dedicated bin in the stockhouse to stock sinter or pre-screened in the stockyard before going to the stockhouse.
- Cold strength: normally measured with the tumble test. The more energy that is used in the sinter process, and the more gangue components such as silica, the stronger the sinter. The cold strength influences the sinter plant productivity because a low cold strength results in a high-fines recycle rate.
- Reduction–disintegration (reduction–degradation index or RDI used in Japan) properties. The reduction from hematite to magnetite generates internal stresses within a sinter particle. The stronger the sinter, the better the resistance to these stresses. The reduction–disintegration properties improve with denser sinter structure, i.e. when the sinter is made with more coke breeze. As a consequence of the higher coke breeze usage, the FeO content of the sinter will increase. From experimental correlations, it is well known that, for a given sinter type, reduction–disintegration improves with FeO content. For an operator this is the fastest way to improve sinter quality, at cost. However, reducibility properties are adversely affected.

The driving force of low temperature reduction–disintegration of sinter is the changeover of the crystal structure from hematite to magnetite, which causes internal stress in the iron oxide crystal structure. So, reduction–disintegration of sinter is related to the fraction of hematite in the sinter. Most sinters contain both primary hematite and secondary hematite (precipitated from the melt).

Particularly the latter causes reduction–disintegration, since it is more easily reduced in the upper part of the furnace than primary hematite (see Figure 3.5).

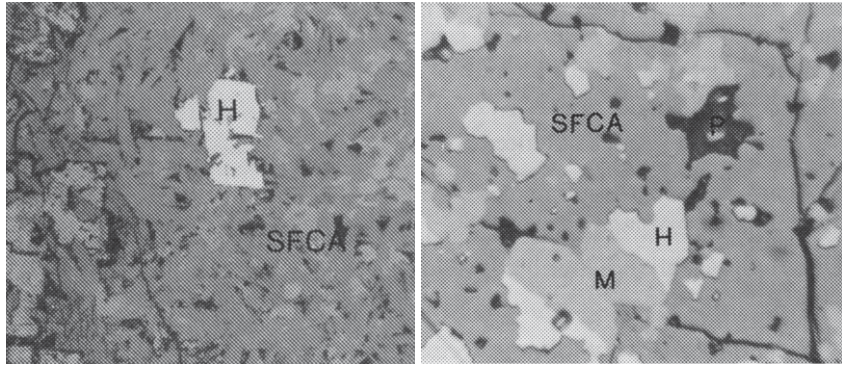

Figure 3.5 Cracking of calcium ferrites (SFCA=silico ferrites of calcium and alumina) due to reduction of primary (left) and secondary (right) hematite (H) into magnetite (M). Pores appear black. (Chaigneau, 1994)

The higher the secondary hematite percentage in the sinter, the more the sinter is prone to reduction–disintegration effects. This can also be said in reverse: that is, there is a strong relationship between the FeO content of the sinter and the reduction–disintegration. The higher the FeO content, the less reduction–disintegration will take place. The FeO content of sinter can be increased by adding more fuel to the sinter blend, which is normally done in the form of coke breeze. However, the precise relationship between the FeO content of the sinter and the sinter quality depends on the ore blend used and is plant–specific.

The reduction–disintegration properties depend on the type of FeO present in the crystal structure. To illustrate this by example; a high fraction of magnetite in the sinter blend will give sinter with a high (primary) magnetite fraction. Moreover, in the presence of sufficient SiO₂ fayalite structures, (2FeO.SiO₂) can be formed. These structures are chemically very stable and can only be reduced at high temperatures by direct reduction reactions (see Section 8.2.1). Alternatively, in the presence of MgO, spinel structures containing large amounts of FeO can be formed. These spinel structures are relatively easy to reduce. Low basicity sinter (CaO/SiO₂ ratio below 1.1) can be produced, but has to be formed at high temperatures and will therefore contain glass–like structures where the FeO is relatively difficult to reduce.

Sinter plants in Europe use for cooling an air–gas mix with a reduced oxygen percentage (12 to 14 %), which suppresses formation of secondary hematite. This results in a relatively high FeO content of the sinter, because less secondary hematite is formed. It has a major benefit for the reduction–disintegration properties of this type of sinter. In addition, the calorific value of the blast furnace top gas increases, as less oxygen has been removed from the ore burden, giving an economic advantage.

During the sintering process there is a major difference between the use of CaO and MgO as fluxes. Both materials are normally added as the carbonate, using limestone as CaCO_3 or dolomite as $\text{Ca.Mg}(\text{CO}_3)_2$. The carbonates are decomposed on the sinter strand, requiring a large energy input. However, the melts containing substantial amounts of CaO have low liquidus temperatures, such as 1100 °C for mixtures of 20 to 27 % CaO and iron oxides. For the melts containing MgO, the spinel structures mentioned above, the melting temperatures are much higher. For this reason, it is easier to form slag–bonds in the sinter using CaO than with MgO. And generally, making sinter with CaO can be done at lower temperature. But sinter with high MgO is more resistant to reduction–disintegration. MgO content can be increased by adding olivine or serpentine to the sinter blend. However, there is an upper limit for MgO content where sinter strength is negatively impacted. Again all these relationships and their limits are plant specific based on raw materials and sinter equipment.

Alumina, present in almost all iron ores in varying quantities, is an undesired element, since at higher levels it increases the sinter RDI. European sinter averages between 0.6 and 1.8 % alumina, whilst RDI is kept around 30 %. Each 0.1 % additional alumina can increase sinter RDI by 2 %. Though alumina promotes SFCA (Silico–Ferrites of Calcium and Aluminum) formation, it also influences the SFCA structure. Higher alumina promotes columnar SFCA against the acicular and dendritic structures, whilst it also increases the viscosity of the primary melt. All this leads to a more brittle matrix structure. As with the effect of most elements in sinter, one must bear in mind that the origin of the alumina (Koalinite, Gibbsite, Bauxite) plays a major role in the fusion process and hence the effect it has on the final sinter RDI. Titanium is also an element reported to have a negative influence on sinter RDI.

For the final result of the produced sinter, it is important to note that the sinter blend prior to sintering is far from homogeneous. It contains various types of material, and locally there are widely varying compositions and sizes present. Ore particles can be larger than 5 mm, coke breeze up to 3 mm and limestone and dolomite up to 2.5 mm. All types of chemical compositions are present on the micro–scale, where the sintering takes place. Types of materials used, size distribution of the various materials, the blending of the sinter mix, the amount of slag–bonds forming materials in the blend, as well as the amount of fuel used for the sintering, all have specific disadvantages for good sinter quality. This makes optimization of sinter–quality a plant–specific technological challenge.

3.4.2 Sinter basicity and sinter plant productivity

During sinter production, the vast majority of the mix is actually melted, and slag bonding with its associated mineralogy is critical for the sinter properties. Sinter basicity heavily imparts the formation of different mineral phases. As acid sinter has a high percentage of brittle silicate glass phases as slag bonding and lacks significant volumes of SFCA, it is weaker than fluxed/super–fluxed sinter.

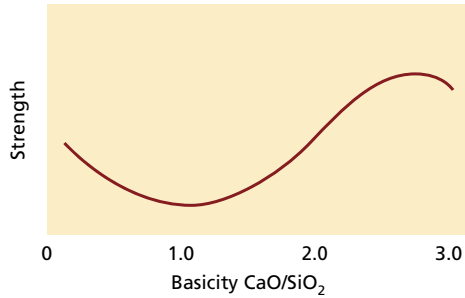

Figure 3.6 Sinter showing poor strength in the basicity range 1–1.4 and superior strength for super-fluxed sinter (after Fernández–González et al, 2017)

The SFCA phase has been shown to be the preferred phase for improving the quality of sinter i.e. strength. Figure 3.6 shows the correlation of sinter strength with basicity. Moreover, flux addition often results in an increase in sinter productivity as the average permeability of the sinter mix improves (especially with burnt lime) and melting phases at lower temperature and viscosity are formed, requiring less time and air volume for sintering. Tumbler index (TI) and low temperature degradation index (LTD) of super-fluxed sinters are comparable to lower basicity sinter. Softening and melting tests indicate that sinter with a basicity of 3.5 has higher softening temperatures compared to lower basicity sinter (basicity below 2.5).

In the above sections the importance of reduction–disintegration of sinter is stressed. The lower the reduction–disintegration, the poorer the reducibility of the sinter. Needle–like structures of calcium ferrites have a relatively open structure and are easily accessible for reduction gas in the blast furnace. In cold conditions the sinter is strong (i.e. good tumbler test results), the degradation during transportation is also good, but the relatively fast reduction in the blast furnace makes the sinter very prone to reduction–disintegration. More solid structures in the sinter have better properties in this respect. Reduction–disintegration leads to poorer permeability of the ore layers in the furnace and impedes proper further reduction of the iron oxides in the blast furnace.

Sinter typically has a basicity (B_2 , CaO/SiO_2) above 1.6. The range of B_2 between 1.6 and 1.9 is very common, higher basicities are being used in specific plants which use a low sinter percentage (below 50 %). Super-fluxed sinter has a basicity above 2 and operation with a basicity of up to 4 has been reported. At increasing basicity, production of the sinter plant (in tonne sinter/ m^2) increases as shown in Figure 3.7 with data from two sinter plants in operation. The effect is large at basicity of 1.6 but decreases at higher basicities. Higher basicity sinter has a lower Fe content, which is compensated by increased production. At a basicity of around 2.5, sinter plant productivity still increases, but no longer compensates the decrease of Fe content, thus bringing less Fe units to the blast furnace. Precise effects are site–dependent and depend among others on burnt lime usage. So, an operator has to review his own historic data.

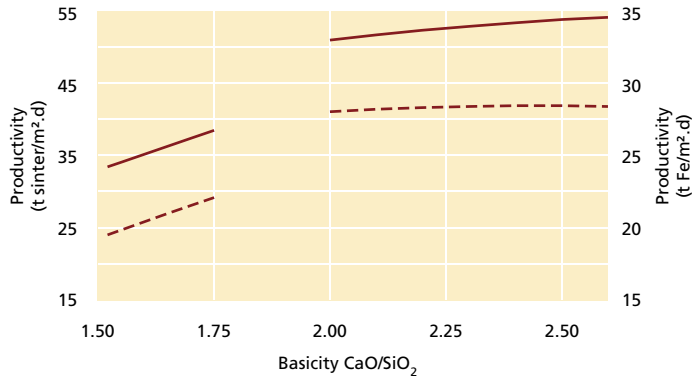

Figure 3.7 Sinter basicity (B_2) and sinter plant productivity, as tonne sinter/ $m^2.d$ (drawn line) and tonne Fe in $t/m^2.d$ (dotted). Data from two different sinter plants.

3.5 Pellets

Similar to sinter, it is the interaction between the iron ore and the pelletizing process that dictates whether high-quality pellets can be produced with high productivity. Unlike sinter, most pellets are produced at the mine site, though especially in China this is changing with some coastal located pellet plants.

3.5.1 Pellet quality

With the correct chemical composition and induration conditions, pellets can be easily transported from mine to blast furnace. Pellets can be stocked and generally remain intact in the blast furnace. Therefore, when judging pellets, the main issues are:

- Chemical composition. Pellet chemical composition in principle can be made to order. However not every ore body lends itself for to a low silica level (below 2.5% SiO₂),
- Cold strength, measured as compression strength and the fines generated through tumbling. Low figures for compression and tumble index indicate bad or lean firing, which results in a pellet with a hard outer shell but an unfired core.
- Pellet sizing. A narrow sizing with limited small pellets enhances overall pellet quality.
- The reduction–disintegration properties. These properties are of less of a concern with pellets than with sinter and lump ore.
- The swelling properties. With incorrect slag composition pellets tend to have extreme swelling properties. Since the phenomenon is well known, it normally does not happen with commercially available pellets.
- The softening and melting. Acid pellets tend to melt at lower temperatures than fluxed sinter and fluxed pellets. More details on softening and melting can be found in Section 10.9.

3.5.2 Pellet chemical composition

Alongside proper induration, the slag volume and composition and the bonding forces mainly determine the quality of pellets. The three main pellet types are:

- Acid pellets (CaO/SiO_2 ratio below 0.5)
- Basic or Fluxed pellets using limestone or dolomite as additives (CaO/SiO_2 ratio between 0.9 and 1.3)
- Olivine pellets, which are acid pellets with a high MgO content produced with olivine as the fluxing additive.

Typical properties of the three types of pellets are shown in Table 3.2.

Pellet Type	Compression	Reducibility	Swelling
Acid	++	–	+/-
Basic	+	+	+
Olivine	+	+	+

Pellet Type	Fe %	SiO_2 %	CaO %	MgO %	Compression (daN/pellet)
Acid	66–67	2–5	< 0.5	0.1–0.6	> 270
Basic	63–66	1.5–4	0.8–1.1	0.1–1.5	> 240
Olivine	64–67	2–4	< 0.5	1.3–1.8	> 200

Table 3.2 Overview pellet properties (daN = Decanewton, around 1.02 kgf)

Acid pellets are strong, but have moderate metallurgical properties. They have good compression strength (over 250 kg/pellet), but may show relatively poor reducibility indices. The softening and melting temperatures are low compared to fluxed pellets or sinter. In addition, acid pellets are very sensitive to the CaO content with respect to swelling. At a CaO/SiO_2 ratio above 0.25, some pellets have a strong tendency to swell, which might jeopardize proper blast furnace operation.

Basic and fluxed pellets have good metallurgical properties for blast furnace operation. By adding limestone or dolomite to the pellet blend, the energy requirement of the firing/induration increases because of the decarbonization reaction. For this reason, production capacity of a pellet plant can sometimes be 10 to 15 % lower when producing basic pellets compared with acid. However, the fluxed pellet reducibility, softening temperature and melting temperature are higher than acid pellets.

Olivine pellets contain MgO in place of CaO, which is added to the blend as olivine or serpentine. The pellets are somewhat weaker when tested for cold compression strength but softening and melting properties are improved.

An important attribute of pellets is their ability to continue to yield a superior agglomerate at minimum silica content. When the ore body and upgrading lends itself, pellets with silica below 1 % can be produced. Low silica pellets

would have in average less than 2.5 % silica and in combination with a sinter burden, this offers the possibility to lower blast furnace slag volume and enhanced productivity through less slag and consequently less coke.

3.5.3 Pellet sizing

Pellets represent the narrowest sized agglomerate in the burden. Though generally over 90 % is quoted to be within the 9–16 mm range, there is an argument for a size range as narrow as possible. The size of the pellets is determined in the green balling stage and subsequent roller screening of these green balls. Upon induration, each pellet receives the same heat treatment, irrespective of its size. Under such conditions, size variations will result in unequal induration and hence in quality variations due to under or over firing. A pellet with a size of 16 mm is already 50 % larger in volume than one of 14 mm. Some pellet suppliers report pellet sizing as narrow as 94 % between 9.5–14 mm.

Large pellets promote a higher burden permeability while smaller pellets reduce more easily. A wide distribution will negatively impact burden permeability, although if pellets are part of a sinter/lump burden, this negative effect will diminish.

3.5.4 Cold compression strength

The difference in compression strength might seem large. However, in the blast furnace the pellets are reduced, and the difference diminishes during reduction. After the first reduction step to Fe_3O_4 , the cold compression strength drops as low as 45–50 daN for acid pellets and to 35–45 daN for olivine pellets. So, a little lower average compression strength has no drawback for the blast furnace process.

However, the average low compression strength can occasionally be the consequence of an increased percentage of very weak pellets (< 60 daN/pellet). That fraction is a good indicator for the pelletizing/induration process: the more pellets that collapse at low compression strength, the poorer the pellets have been fired. Therefore, pellet quality can be influenced by the production rate: the slower the grate moves, the stronger the firing can be, so the induration period increases and the pellets become stronger.

Though it is sometimes claimed that pellets need to be strong to support the burden on top, actual calculations show that the theoretical strength of a pellet needs to be minimum: with a ferrous burden density of 1800 kg/m³, the weight per cm² (roughly the cross-sectional surface area of a single pellet of 11 mm) is 0.18 kg. A column of 20 m height of ferrous burden imposes a static “pressure” of 3.6 kg on this single pellet only. Factors like burden movement, blast pressure counteracting the downward pressure, bridging and coke will offset this calculated pressure.

3.5.5 Swelling

As mentioned above, pellets, in contrast to sinter and lump ore, can have the tendency to swell during reduction. Generally, a volume increase of up to 20 %, measured according to ISO 4698, is seen as acceptable. Abnormal swelling can easily go over 100 % volume increase. The effect of swelling, however, depends on the percentage of pellets used in the burden. Abnormal swelling may occur during the transformation of wustite into iron. Like any transformation, this is a balance between iron nucleation and growth of these nuclei. During swelling, limited nucleation occurs and these nuclei grow like needles causing a volume increase which is seen as swelling, see Figures 3.8. These needles, called whiskers, are difficult to observe; a microscopic image of the phenomenon is shown in Figure 3.9. Under certain conditions, for example in the presence of alkalis in the blast furnace, the swelling can become excessive and a cauliflower–structure develops with cracks (Figure 3.8). This coincides with a low compression strength of this structure, with the risk of generating fines.



Figure 3.8 Balance between iron nucleation and nuclei growth. Limited swelling accompanied by the formation of an iron shell (left). Limited iron nucleation followed by strong needle growth of the nuclei with as a result excessive swelling of the pellet (right).

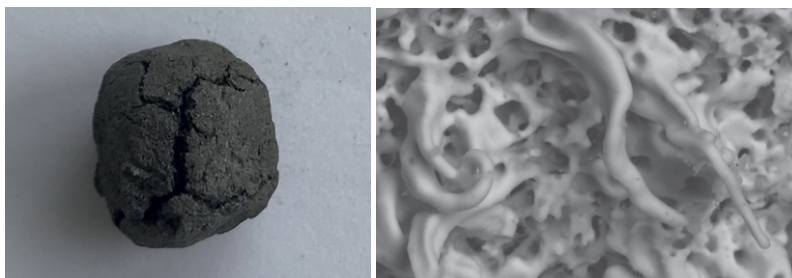

Figure 3.9 A swollen pellet and its Whisker formation

Main factors influencing pellet swelling are basicity and gangue (non-iron compounds) content. Figure 3.10 shows how swelling depends on pellet basicity. Pellets with a basicity between 0.2 and 0.7 are more prone to swelling.

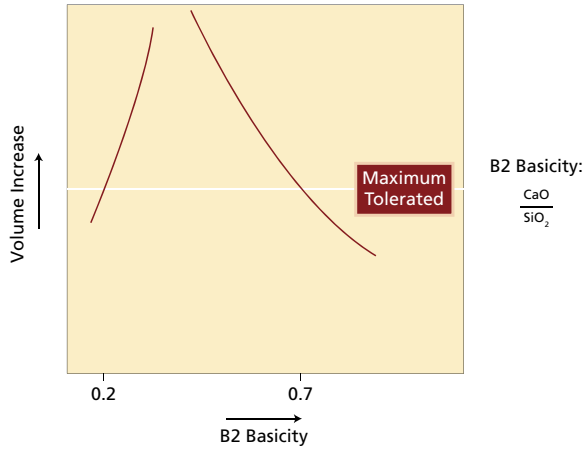

Figure 3.10 Volume increase of pellet by swelling with increasing basicity.

Swelling is mitigated by proper induration. In the blast furnace local process conditions like temperature and gas composition greatly influence the swelling behavior. At higher reduction degrees also, swollen pellets will shrink. The Japanese measure this shrinkage in a Contraction Test and have empirical data showing that pellet contraction over 10% in a large blast furnace has negative impact on productivity and reductant rate. As the phenomenon of swelling is well known, it is normally under control with commercially available pellets, but always requires a check because it could have a severe impact on the regularity of the blast furnace process.

3.5.6 What are good pellets?

An overview of pellet properties is shown in Table 3.3. As pellets can be produced as acid and fluxed pellets, whereas sinter is generally fluxed and lump ore always acid, a difference in LTD and reducibility indices becomes apparent.

	What is measured?	Results	Acceptable Range	Reference
Mean Size	Size distribution	% 6.3–16 mm % < 6.3 mm	> 95 % < 2 %	ISO 4701
Cold Strength	Compression Strength Tumbling Strength and Abrasion	Average kg/p % < 60 kg/p % > 6.3 mm % < 0.5 mm	> 150 daN/p < 5 % > 90 % < 5 %	ISO 4700 ISO 3271
LTD (Low Temp. Breakdown)	Size distribution after static reduction and tumbling	% > 6.3 mm	> 80 %	ISO 4696
Reducibility	Weight decrease during reduction	%/min (dR/dt) ₄₀	> 0.5 %/min	ISO 4695

Table 3.3 Characterization of acid and fluxed pellets

This difference is mainly driven by the ISO test conditions themselves, immediately showing some of the limitations of ISO tests. Since an acid pellet does not readily reduce at low temperatures, it sustains a higher intrinsic strength (high LTD) against the more reducible fluxed pellet. However, this does not imply that an acid pellet does not reduce or disintegrate. It will happen only at more elevated temperatures in the furnace.

3.6 Lump ore

Lump ores are natural iron-rich materials, which are used directly from the mine after the crushing and screening operations. Because the lump ores are screened out at the mine, such operations generally produce lump ore as well as (sinter) fines. Major lump ore deposits are present in Australia (Pilbara region), South America (Iron Ore Quadrangle), South Africa (Sishen) and Canada (Baffinland). In many other places limited amounts of lump ores are produced. Good lump ores are becoming more and more scarce.

The lump ores demand generally a lower premium than pellets. For this reason, in many blast furnaces, high amounts of lump ore are being considered. The lower cost of the lump ore compared with pellets as a manufactured burden component is offset by the poorer physical and metallurgical properties.

Generally speaking, in comparison with pellets, lump ores, which will also be screened before transport at the dispatch port:

- Have a yield penalty where more fines need to be screened before charging to the furnace, ranging from hardly any to over 25 % in case of severe handling prior to charging.
- Some lump ores have a high moisture input into the furnace, either from “intrinsic” moisture or because the lump was washed to remove fines.
- May have “Loss On Ignition” (LOI). The weight loss comes mainly from crystalline water in goethite lump ores that is released as the lump ore is heated in the furnace shaft. As a consequence of this crystalline water driven off at high temperature, lump ores may show degradation, called decrepitation. The level of decrepitation depends on the amount of crystalline water and the density of the lump. A low LOI in a dense lump ore may show higher decrepitation than a high LOI in a porous lump, where the crystalline water can more easily escape. The disintegration effect is tested with the decrepitation test.
- May have poorer reduction degradation properties and or may have poorer reducibility properties. Dense lump ores are generally stronger, but harder to reduce. Poor reducibility is only translated into a coke penalty when the direct reduction increases.
- Will have a lower melting temperature when they exhibit a higher natural acid gangue content.
- Have greater diversity in physical properties due to being naturally occurring and a broader sizing.

Consequently, lump ores may be penalized by an increased coke demand. Lump ore is used in an appropriate size fraction, such as 8–40 mm. For blast furnace operation at high productivity and high coal injection levels, lump ore may not be the preferred burden material, but lump ore is a natural material, and its properties will differ from type to type. Certain types of lump ores can compete favorably with sinter, and for example the Ternium Siderar blast furnaces in Argentina have operated successfully with up to 40 % in the burden using a Brazilian lump ore at high furnace productivity.

3.7 Metallics charge and briquettes

Two other components with ferrous content can be charged to the blast furnace:

- Metallics like Hot Briquetted Iron (HBI, Figure 3.11), Direct Reduced Iron (DRI) and steel scrap to increase the productivity and efficiency of the blast furnace whilst limiting the greenhouse gas exposure.
- In-plant revert as briquettes. Especially if an on-site sinter plant is not available, valuable revert materials containing iron, manganese, carbon and fluxes can be charged with the burden. The phosphorus level is the limiting factor in many cases.



Figure 3.11 Hot Briquetted Iron (HBI)

Direct reduced iron (DRI) is seen more and more as a feedstock for blast furnaces. After hot briquetting in the form of HBI it can be charged with the other burden components, and with this HBI addition the hot metal production is increased for situations where a mill is hot metal short. An advantage may be secured in this way over charging these metallics directly into the converter.

Typically, HBI contains over 90 % Fe and has a metallization degree in excess of 90 %. Since the metallics only need to be melted and hardly reduced, a coke rate decrease per tonne of hot metal is achieved, and this helps to lower the carbon dioxide generation at an integrated steel plant. Table 3.4 on the next page provides typical compositions of HBI in comparison with typical sinter and pellets.

	Fe	FeO	Met.Fe	SiO ₂	CaO	Al ₂ O ₃	MgO	C
HBI	92	15	80	2.0	0.9	0.8	0.3	1
Sinter	58	7	0	4.5	9.2	1.7	1.1	0
Pellet	65	0	0	4.5	1.0	0.4	0.4	0

Table 3.4 Typical chemical composition of HBI versus sinter and pellets

In our experience, if 100 kg HBI/DRI/Steel Scrap is used per tonne of hot metal, the productivity increases by 4–6 % and the coke rate can be decreased by 30 kg/tHM.

Cold briquetting of in-plant reverts, such as blast furnace dust, BOF sludge and mill scale, is a way to recycle these materials. The preferred way is to recycle them through the sinter process. In North America, some sinter plants only operate on these waste materials, whilst other locations lack such sinter capacity and need to landfill them, sell them or recycle them via the briquetting route. These cold bonded briquettes often have cement as a bonding agent resulting in high strength cold properties but poorer reduction disintegration characteristics. Cold briquettes offer the option of incorporating carbon, which improves reduction properties.

3.8 Interaction of burden components

The results of burden tests on the total burden can differ greatly from results on sinter, pellets and lump ore alone. An example is provided in Figure 3.12. A relatively poor quality of lump ore is blended with good sinter. It is shown that the behavior of the blend is better than expected from the arithmetic mean of the data.

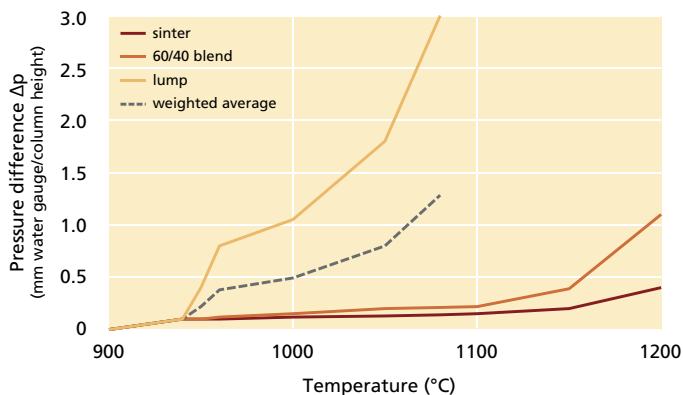

Figure 3.12 Softening behavior of sinter, lump ore and a 60/40 blend, softening is indicated by an increase in the pressure difference (from Chaigneau – 5th ECIC, Stockholm, 2005)

Example 3.1 Effect of blending sinter and pellets in a blast furnace

In a blast furnace (1880 m³ inner volume) the pellets were blended over the full length of the conveyor belt. Prior to dedicated efforts to make the ferrous blend consistent there were no strict requirements on mixing ratio of burdens on belt. In that situation gas flow was unstable, especially when lump rate was increased. It was impossible to reach a lump percentage above 15 %. The ferrous blend was made more consistent by mixing pellets and lump over a much larger length of the sinter charge on the main conveyor belt. Pellets and lump were no longer charged in the center area. The blast furnace showed the following operational results.

- (1) Central gas flow was more stable after the change. This is indicated by Z value in Figure 3.13 (Z is central temperature divided by average temperature).

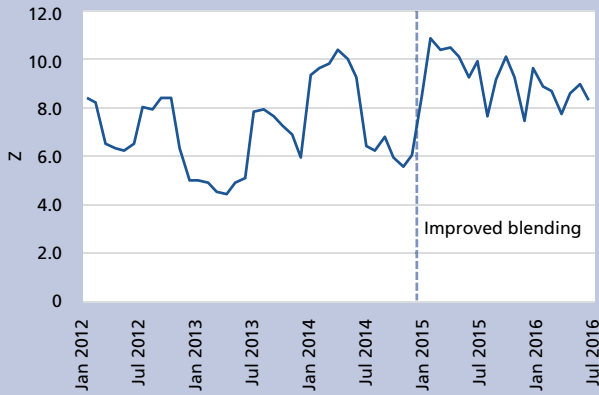

Figure 3.13 Effect of improved blending on central gas flow stability

- (2) Lump rate was increased gradually, max up to 21 % in January 2016, as shown in Figure 3.14.



Figure 3.14 Lump ore rate, January 2015 to March 2016

Generally speaking, blending materials dilutes the disadvantages of a certain material. For this reason, the blast furnace burden components have to be properly blended when charged to the furnace. More details on softening and melting can be found in Chapter X.

In this respect, burden components should be chosen to be either comparable in composition, like fluxed sinter with fluxed pellets to yield one desired softening and melting outcome, or one should choose compatibility with for example a very distinct super-fluxed sinter in combination with acid pellets. Super-fluxed sinter has a high softening temperature and keeps the cohesive zone permeable for gas to high temperatures. In Section 10.9.6 scenarios for using pellets at high pellet operation are discussed.

The permeability of the cohesive zone for gas can also be improved by adding different types of material to the ferrous burden. Nut coke remains solid and is used by most steel plants blended into the ferrous burden; a similar effect is also generated by using scrap and/or HBI, since these materials melt as well at high temperatures.

3.9 Chemical control of the burden

Though the aim of a blast furnace is to make iron, the importance of all other components coming with the burden as discussed in Section 3.2 cannot be neglected and a certain burden composition is required to achieve a balance between these components. The vast majority will be tapped as slag during a hot metal tap, though some will partition between slag and hot metal, such as silica, manganese and sulfur and others, like phosphorus, will completely revert to the hot metal phosphorus.

Silica, together with alumina represents in quantity the bulk components originating from the ore gangue and coal and coke ash. They need to be fluxed with CaO and some MgO to achieve the slag chemistry for good liquid slag and appropriate desulfurization. A low slag volume is desired but depends on the quality of the raw materials available. Beneficiation of the raw materials to a desired low gangue and ash levels at the mine site is not always possible or comes with increasing cost and yield losses. Furthermore, some gangue is required to attain a proper sinter quality. Operators will not go below a 3.5 % silica level in their sinter, with 4.5–5.5 % being more common.

With pellets, a good quality can still be obtained with low gangue levels, and consequently blast furnaces operating with 100 % pellets can achieve the lowest slag volumes per tonne of hot metal. This is one of the merits of low silica pellets in lowering slag volume and enhancing stable and high productivity with low coke rates and high PCI levels

As an example: what does it mean when the burden contains 1 % more silica (SiO_2)? Since we charge about 1600 kg burden per tonne of hot metal, 1 % additional silica means 16 kg of silica contribution, which for such an addition all ends up in the slag. Since slag contains 35–40 % SiO_2 , the slag volume increases by a factor 2.5–3 or 40–50 kg/tHM, as also extra fluxes have to be charged. So, the slag volume increases by 40–50 kg/tHM, coke breeze consumption in the sinter process increases by 1 kg per tonne of hot metal and coke consumption in the blast furnace increases by 2–2.5 kg/tHM, while blast furnace productivity will decrease.

The amount of alumina in slag is generally limited to levels below 18–20 %, though some operators have learned to exceed these boundaries. If the burden composition does not allow for lower alumina levels, the only solution is to increase the total slag volume with a siliceous component and dilute the high level of alumina to acceptable levels. In this case the slag volume is dictated by alumina rather than based on silica in the ores. Low alumina levels below 8 % generate a difficult slag as well.

Slag MgO levels vary in the range of 5–12 %. The furnace process is more forgiving if a range of 8–11 % MgO is maintained, if the increase in weight percentage of MgO is compensated by a decrease in weight percentage of CaO.

When a desirable burden composition has been established, fine tuning can be achieved by charging small amounts of high siliceous ore, quartzite, or direct charge fluxes such as BOF slag, limestone or dolomite to the burden. The latter two are carbonates, which require a considerable amount of heat in the blast furnace for decomposition, which preferably should take place in a sinter plant with coke breeze. Daily operational control is further discussed in Chapter X.

This page intentionally left blank

IV Coke

4.1 Function of coke in the blast furnace

Coke is a strong, non-melting material which forms lumps based on a structure of carbonaceous material internally glued together (Figure 4.1). The average size of the coke particles is much larger than that of the ore burden materials; average size of coke is 45–55 mm and of ferrous burden materials 12–22 mm. Coke does not melt and is a solid and permeable material up to very high temperatures (above 2000 °C). This is of particular importance in the hearth and melting and softening zone. Because of its large size coke is permeable for gas and liquids.



Figure 4.1 Coke

- For blast furnace ironmaking the most important functions of coke are:
- To provide the structure, through which gas can ascend and be distributed through the burden supporting the total weight of the blast furnace content in and above the cohesive zone allowing slag and iron to flow downwards to the taphole.
 - To generate heat to melt the burden.
 - To generate reducing gases to remove the oxygen attached to iron in the ferrous burden.
 - To provide the carbon for carburization of the hot metal (also called dissolution of carbon)
 - To act as a filter for soot and dust.

The permanent efforts aimed at reducing the costs of ironmaking have led to an increasing portion of substitute reduction materials for coke, which has mainly been coal injected through the tuyeres and recently natural gas in North America. Nowadays, blast furnaces with total coal injection rates in excess of 200 kg/tHM are operated with coke consumptions of less than 300 kg/tHM. At these high coal injection rates, coke is subjected to more rigorous conditions in the blast furnace. Dissection of furnaces taken out of operation, along with probing and sampling through the tuyeres of furnaces in operation, have allowed assessment of the extent of coke degradation in the furnace. Coke degradation is controlled by the properties of feed coke, i.e. mechanical stabilization, resistance to chemical attack (solution loss, alkalis, and graphitization) and by the blast furnace operating conditions.

In Figure 4.2 we show the residence time of coke in various zones. In the “drying” zone, before the burden starts melting, the coke is exposed for 3–6 hours in the blast furnace gas flow. In the cohesive zone and the active coke zone, the coke is present for 1–3 hours and is subjected to high temperature and aggressive attack by chemical reaction (direct reduction reactions, alkali). In the hearth the coke residence time is much longer, especially in the more central part called “deadman”. There the residence time is from a week to two months. As soon as coke reaches the area below the tuyeres, there is very little “chemical” consumption of coke left nor is there a large dissolution of carbon in the hot metal.

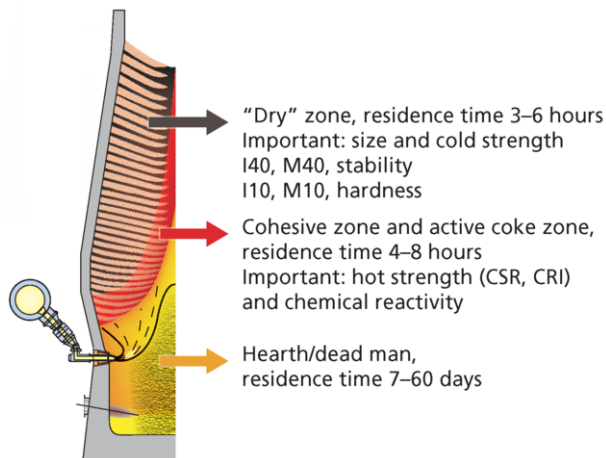

Figure 4.2 Residence time and quality parameters for coke in various zones in the blast furnace

In this chapter we will discuss coke quality parameters, test methods, degradation processes of the coke in the blast furnace, and finally the range of coke qualities targeted by blast furnaces that are currently at, or are aiming to operate at, the highest production levels, so are more demanding in terms of coke quality.

4.2 Coal blends for coke making

The coal selected to make coke is the most important variable that controls the coke properties. The rank and type of coal selected impacts coke strength, while coal chemistry largely determines coke chemistry. In general, bituminous coals are selected for blending to make blast furnace coke of high strength with acceptable reactivity and at competitive cost. For the conventional recovery coking process, the blend must contract or shrink sufficiently for easy removal from the oven, and oven wall pressure must be acceptable to prevent coke oven damage. For the heat–recovery method of coke making, these constraints are not valid, which leads to an increase of usable coal types in this type of process. Good coking coals are expensive and for this reason creating a coal blend that gives good coke at minimum cost is specialist work.

Table 4.1 shows the typical chemical composition of coke that may be considered to be of good quality.

Typical Coke Analysis		% (db)	
Coke Analysis	Fixed Carbon	87–92	
	Nitrogen	1.2–1.5	
	Ash	8–12	
	Sulphur	0.6–0.8	
	Volatile Matter (for well carbonised coke)	0.2–0.5	
	Hydrogen	0.2	
Ash Analysis	Silica	SiO ₂	52.0
	Alumina	Al ₂ O ₃	31.0
	Iron	Fe	7.0
	Lime	CaO	2.5
	Potassium	K ₂ O	1.8
	Magnesia	MgO	1.2
	Sodium	Na ₂ O	0.7
	Phosphorous	P	0.3
	Manganese	Mn	0.1

Table 4.1 Coke chemistry for good coke quality

Fixed carbon content of coke C_{fx} can be estimated as follows (all percentages):

$$C_{\text{fx}} = 100 - \text{ash} - S - \text{VM} - N$$

VM is volatile matter, N is nitrogen, typically 1.3 % and often not taken into account.

Ash directly replaces carbon, so higher ash results in higher slag rate and lower energy value. The increased amount of slag requires energy to melt and more fluxes to provide a liquid slag. Ash, sulfur, phosphorus, alkalis and zinc can be best controlled by careful selection of all coal, coke and burden materials. The financial repercussions of ash, sulfur and phosphorus may be assessed by value-in-use calculations for PCI coal, coking coal blends and burden materials. Alkalis and zinc should remain below certain threshold levels (Chapter VI).

4.3 Coke quality

How to characterize coke quality? How to define and measure coke properties? In other words, how to establish a target for coke manufacturing based on determined coke properties in line with the needs of the blast furnace process. From the above discussion, the following parameters should be considered to limit the coke degradation and maintain suitable coke behavior in the blast furnace, especially at high coal injection rates. Qualitatively the coke should:

- Be made up of large, stabilized particles within a narrow size distribution band.
- Have a high resistance against volume breakage.
- Have a high resistance against abrasion.
- Have a high resistance against chemical attack (CO_2 , alkali).
- Have a high residual strength after chemical attack.
- Have sufficient carburization properties (the dissolution of carbon in hot metal).

A more detailed description of coke quality tests is added in Annex VI, summarized in Section 4.5.2.

4.3.1 Coke degradation mechanisms in the blast furnace

The basic concepts of coke degradation in the blast furnace, according to the interconnected thermal, physical, and chemical conditions coke is subjected to in the furnace, are described in Figure 4.3.

At the stockline, the coke is generally well stabilized due to handling to get it to the furnace top. The effect of gasification on strength is controlled by the mechanisms of the heterogeneous reaction. In general, diffusion is the limiting step and the reaction is located at the surface of the lumps, the core remaining quite unaffected. As gasification and abrasion proceed simultaneously, a peeling of coke particles occurs (3–5 mm size reduction), leaving an exposed unreacted core and fines.

Beyond gasification, coke reacts with alkali vapors when passing through the alkali circulating zone, and the structure is penetrated by alkalis. This reaction reduces the strength of the coke, making it more susceptible to size reduction by breakage from mechanical action. Coke that has been already weakened, on arriving in the high temperature zone of the raceway, loses its alkalis by gasification. High temperature, mechanical action and graphitization bring about severe degradation, decrease of size and the formation of fines.

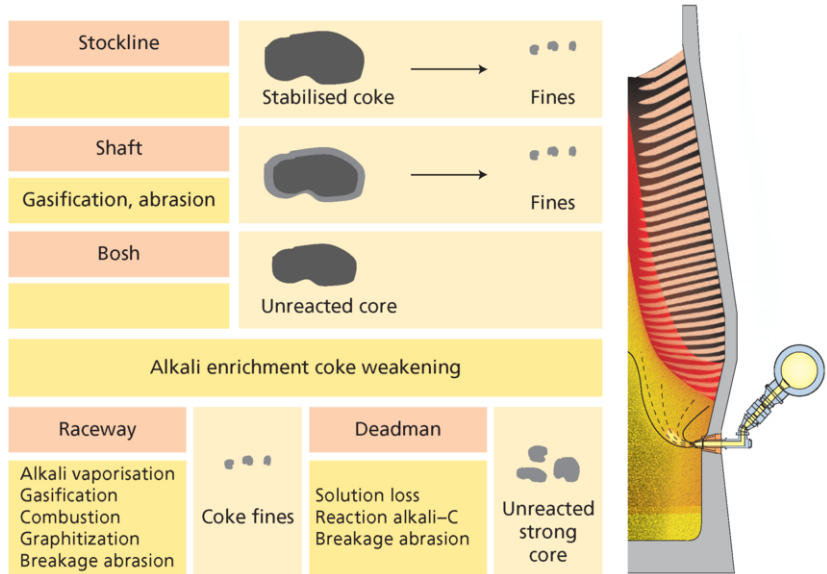

Figure 4.3 Basic concepts of coke degradation in a blast furnace

The coke travelling to the deadman is exposed to moderate temperatures, high alkalis during long periods of time, along with additional reactions (reduction of slag, carburization) that mostly affect the surface of the coke lumps. Deadman coke, sampled by core drilling, corresponds more or less to the unreacted core of the initial lumps, and it is not surprising that it exhibits similar strength to the coke that is charged at the top.

Example 4.1 Harmonic mean size and average mean size

The average mean size (AMS) is the weighted average of the size fractions, the harmonic mean size (HMS) is the weighted average of 1 divided by the size fractions and consequently places emphasis on smaller particles.

This is shown in Table 4.2. So, the average mean size correlates with volume (weight) of a mixture, while the harmonic mean size correlates with the average surface of a mixture.

Size (mm)	25	35	50
Fraction	0.2	0.3	0.5
Average Mean Size	40.5	0.2·25+0.3·35+0.5·50	
Harmonic Mean Size	37.6	1/(0.2·1/25+0.3·1/35+0.5·1/50)	

Table 4.2 Calculation of AMS and HMS

4.3.2 Degradation of coke during its descent in the blast furnace

During its descent through the blast furnace coke, is subjected to the process conditions and gradually degrades, as shown by the evolution of coke size in Figure 4.4. Research has shown that the harmonic mean size (HMS), of the coke mass yields the highest correlation with the resistance to flow of gas passing through the coke bed.

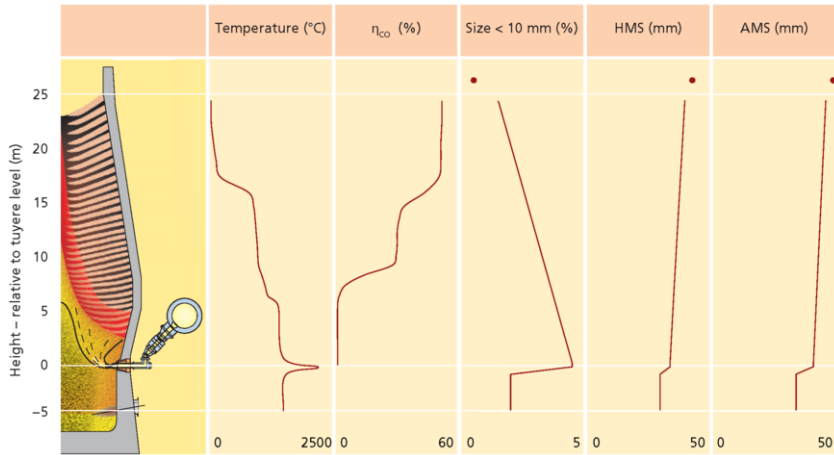

Figure 4.4 Coke size in the blast furnace throughout the journey from the top to the bottom of the furnace. HMS and AMS: Harmonic and Average Mean Size. Data for temperature and η_{CO_2} for wall area (Chaigneau, 2001), coke sizes as measured for operating furnaces. Dots represent feed coke.

Coke is exposed to stresses and (chemical) attack during its journey downwards.

1. Charging zone: Due to the fall of the coke onto the stockline, some breakage and abrasion will occur during charging.
2. Granular zone: In this region the coke and ore remain as discrete particles within their separate layers. Drying occurs, and recirculating elements such as zinc, sulfur and alkalis, deposit on the burden materials as they descend to the bottom of the granular zone. From a temperature of 900 °C coke starts to oxidize with CO_2 , continuing to do so as the temperature increases to over 1000 °C. In this zone coke degradation (mostly abrasion) occurs due to mechanical load and mild gasification.
3. Cohesive zone: This zone starts where ore agglomerates, begins to soften and deform, creating a mass of agglomerated particles sticking together. This mass is barely permeable, and the rising gas can only pass through the remaining coke layers. Coke gasification with CO_2 becomes significant due to increased reaction rates at the higher temperature level (1000 – 1300 °C). The contact between the softened or molten materials and the coke lumps becomes more intensive, leading to increased mechanical wear on the outer surface of the coke particle. The residence time within the cohesive zone is rather short (30 to 90 minutes) depending on productivity and softening properties of the agglomerates.

4. Active Coke or Dripping zone: This is a packed bed of coke through which liquid iron and slag percolate towards the furnace hearth. The coke particles play an active role in further reducing the remaining iron oxides and increasing the carbon content of the iron through dissolution of carbon from the coke into the iron. The bulk of the coke arriving in this zone (also referred to as bosh coke) flows towards the raceway region. The remaining part will move into the deadman (also called inactive coke zone). The residence time varies from 1 to 3 hours. The temperature increases gradually from 1200 to 1500 °C.
5. Raceway: Hot blast containing oxygen is introduced through the tuyeres. The kinetic energy of the blast creates a raceway (cavity) in front of each tuyere. Coke particles circulate at very high velocity in this semi-void region while being gasified together with injectants such as coal, oil and natural gas. A part of the coke and injected reductants is not burnt completely. Soot is produced during injection of coal and natural gas. Soot and dust are transported upwards by the gas stream. They cover coke particles and react later following solution loss reaction. They decrease the reactivity of coke and cause an increase in apparent viscosity of liquid phases. The temperature increases rapidly to over 2000 °C due to the exothermic oxidation of coke and injectants. Coke fines and injectant fines that are generated in the raceway either completely gasify or get blown out of the raceway into the coke bed. Coke and coal fines may accumulate directly behind the raceway, forming an almost impermeable zone called the bird's nest. Observations of the raceway were made in blast furnaces in operation by inserting an endoscope through a tuyere. These observations showed that in this zone the coke is subjected to very severe conditions.
6. The Hearth: Since the rate of coke consumption is highest in the ring of the raceway, an almost stagnant zone (not directly feeding the raceway) develops in the furnace center. This zone is called the deadman, and is thought to have a conical shape and a relatively dense skin structure. Molten iron and slag accumulate throughout the structure before being tapped through the tapholes. Tracer experiments in a German furnace gave values in the range of 10 to 14 days, but residence times of 60 days are also mentioned in the literature for the deadman coke.

The above mentioned processes are summarized in Table 4.3 on the next page.

At high coal injection rates the amount of coke present in the furnace decreases and the remaining coke is subjected to more vigorous mechanical and chemical conditions: increased mechanical load as the ore/coke ratio becomes higher; increased residence time at high temperatures; increased solution loss reaction (CO_2 , liquid oxides); and alkali attack. More severe coke degradation during its descent from the furnace stock line into the hearth can therefore be expected at high coal rates.

Blast Furnace Zone	Function of Coke	Coke Degradation Mechanism	Coke Requirements
Charging Zone		– Impact Stress – Abrasion	– Size Distribution – Resistance to Breakage – Abrasion Resistance
Granular Zone	– Gas permeability	– Alkali Deposition – Mechanical Stress – Abrasion	– Size & Stability – Mechanical Strength – Abrasion Resistance
Cohesive Zone	– Burden support – Gas permeability – Iron and slag drainage	– Gasification by CO ₂ – Abrasion	– Size Distribution – Low Reactivity to CO ₂ – High Strength after Abrasion
Active Zone	– Burden support – Gas permeability – Iron and slag drainage	– Gasification by CO ₂ – Abrasion – Alkali attack and ash reactions	– Size Distribution – Low Reactivity to CO ₂ – Abrasion Resistance
Raceway Zone	– Generation of CO	– Combustion – Thermal Shock – Graphitisation – Impact Stress and Abrasion	– Strength against Thermal Shock and Mechanical Stress – Abrasion Resistance
Hearth Zone	– Burden support – Iron and slag drainage – Carburisation of iron	– Graphitisation – Dissolution into hot metal – Mechanical Stress	– Size Distribution – Mechanical Strength – Abrasion Resistance – Carbon Solution

Table 4.3 Coke functions, degradation mechanisms and requirements

However, high coal injection rates can also affect the direct reduction reactions.

1. Coal injection increases hydrogen content and at elevated temperatures (800–1100 °C), hydrogen is a very effective agent in gas reduction of iron oxides.
2. The unburnt coal char remaining after the raceway is more reactive than coke and used for direct reduction in preference to coke.
3. The alkali cycle is reduced as a consequence of the elimination of alkali through the hot furnace center.

So, at high coal injection rates the attack of coke by direct reduction reactions and by alkalis may also decrease. This is beneficial for coke integrity in the lower part of the furnace.

4.4 Coke size distribution

The shape of the coke particles and the size distribution of the particles are the decisive factors for the permeability of the coke bed, for ascending gas as well as for the descending liquids.

The lowest flow resistance is obtained when large coke is being used of high uniformity. Fines in particular have a strong decreasing effect on the harmonic mean size, which increases the bulk resistance of the coke. Coke screen aperture size is generally between square holes of 24 and 35 mm, although on some plants this is as high as 40 mm. The size selected depends on the screening

efficiency and how well the coke has been screened before arriving at the stockhouse. The objective is to remove the fine coke. Typical specifications for coke after screening is maximum 2 % smaller than 25 mm or maximum 3 % smaller than 30 mm. The undersize after screening is partly used in ferrous layer as nut coke, where it replaces the coarser coke. Details in Section 4.8.

Once the bulk coke has been classified by screening and crushing (see also Figure 4.4), the aim is to have a resultant coke with high mechanical strength under the blast furnace conditions. This is to prevent an excessive formation of coke fines during its descent in the blast furnace.

4.5 Strength of coke

4.5.1 Coke particle size during the blast furnace process

During carbonization in a coke oven, fissures in the coke are generated due to stresses that arise from the differential contraction rates in adjacent layers of coke, which are at different temperatures. They are typically longitudinal, that is perpendicular to the oven walls. Additionally, many transverse fissures are formed during pushing. These fissures determine the size distribution of the product coke by breakage along their lines during subsequent handling. But not all the fissures lead to breakage at this early stage, and a number of them remain in the coke particles. The initial coke distribution is a function of the coal blend and the coking conditions. A significant number of internal fissures remain present and cause further degradation under mechanical loads during transport and charging of the blast furnace. This process of coke degradation is called stabilization. Stabilization lowers the mean size of the coke, but the resulting particles are less prone to further breakage. For blast furnace performance, it is not only important to have large, stabilized and narrow size distribution coke charged into the furnace, but it is even more important to have the same qualities present during its descent through the furnace as well. With mechanical handling, coke particles will degrade due to breakage and abrasion. Breakage is the degradation of coke by impact due to fissures already present in the coke. Abrasion is the degradation of the surface by relatively low impact processes (rolling and sliding against other particles or the furnace walls). It is one of the main mechanical processes for decreasing the coke size below the stock line, next to breakage in the raceway area. Abrasion causes the formation of fines which may hamper blast furnace permeability.

The resistance to abrasion will deteriorate in the blast furnace, due to reactions such as graphitization, gasification and carburization of the iron. Graphitization results in a more crystalline form of carbon in the coke that is more brittle. In Figure 4.5 the typical development of the HMS of coke from the coke wharf to the tuyeres is presented.

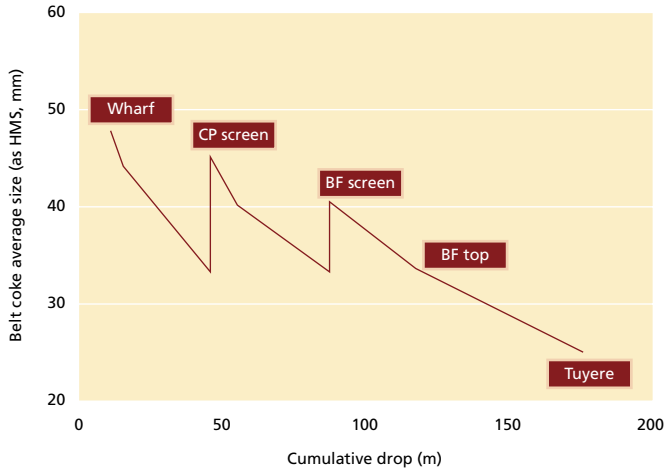

Figure 4.5 Development of Harmonic Mean Size after mechanical handling in the form of drops between conveyors and screens

In the transport route presented, the coke is screened at 35 mm (square) at the coke plant and at 24 mm (square) at the blast furnace. The increase in HMS of the sample after screening is due to the removal of the undersized coke.

4.5.2 Coke cold strength simulation tests

Although it is known that coke degrades more rapidly at high temperatures, there is no test in practical use that is performed at high temperatures. Not only because of the complexity and high costs, but also because it has been shown that coke with poor low-temperature strength also exhibits poor strength at high temperatures. For this reason, most tests in practical use are done at ambient temperature.

Coke strength is traditionally measured by empirical tumble indices. During mechanical handling, coke size degradation takes place via two independent processes, these being breakage into smaller lumps along fissures and cracks still present in the lumps, and abrasion at the coke surface resulting in small particles (smaller than 10 mm). So, it is common to measure a 'strength' index related to degradation by volume breakage, for example, I_{40} , M_{40} , stability index; and an 'abrasion' index, for example, I_{10} , M_{10} , D_{150} . These empirical indices cannot be directly related to fundamental coke properties.

Figure 4.6 shows a schematic representation of particle motion in a tumble drum. As lifter bars inside the drum rotate, a portion of the coke is lifted off the walls of the drum. Some of the coke rolls off the lifter before it reaches the horizontal plane. The coke that is not picked up slips and rolls against the bottom of the drum. The coke that is lifted past the horizontal is dropped over a fairly narrow angular range as the lifter approaches the vertical plane.

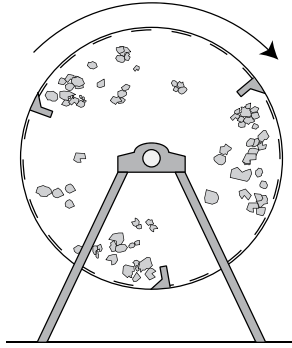

Figure 4.6 Motion of coke in a tumble test

This coke impacts with the bottom of the drum. Tests have shown that there is a relationship between the degradation of coke in a drum test and that after a number of drops. This makes it possible to translate the effect on coke size after a number of drops, in meters, into a number of rotations in a drum, and vice versa.

4.5.3 Coke hot strength and chemical reactivity

Besides a high mechanical strength, coke should have a high resistance against chemical attack. There are two measurements for coke after the reaction with CO: the CRI (Coke Reactivity Index) and the CSR (Coke Strength after Reaction).

Coke Reactivity Index

Reactivity of coke can be tested in numerous ways, but by far the most common way to determine coke reactivity is the Nippon Steel Chemical Reactivity Index (CRI). With this test, a sample of dried coke of 19–22,4 mm is put in a 100 % CO₂ atmosphere at 1100 °C. The percentage of coke that is gasified after 120 minutes yields the CRI value. The more reactive the coke, the higher the mass loss will be. The reactivity of the coke is mainly determined by the chemical composition of the parent coal blend, because ash components act as catalysts for the reaction of C with CO₂.

Coke Strength after Reaction

Due to the loss of mass whilst under attack by CO₂, the surface layer of the coke particles becomes very porous and the mechanical strength against abrasion drops rapidly. To measure this effect the reactivity test is normally followed by a tumbler test to determine the residual coke strength. The percentage of particles that remain larger than 10 mm after 600 rotations is called the 'Coke Strength after Reaction' or CSR index. For most coke produced there is a strong correlation between CRI and CSR. As CRI decreases, CSR increases.

Before CRI and CSR were developed, a series of relatively expensive tests were carried out under various research projects that involved partially gasifying the coke in its original particle size under realistic blast furnace conditions before subjecting it to the standard drum test. While the results of this costly research work showed exactly how the coke in the blast furnace was subjected to chemical attack, it provided no better information on coke quality than the simpler method of determining CRI and CSR. These two parameters are now generally adopted by the coke-making industry as the most important parameters for determining coke quality, especially on large blast furnaces with high productivity and high tuyere injectant rates.

Carburization of Hot Metal

There is no standard test for the dissolution of carbon in hot metal, the carburization. Experiments were conducted on this by the Institute of Ferrous Metallurgy in Germany to compare different cokes of different coal blends and coke making technologies. The experiments showed very similar behavior between most cokes. The only exception was the traditionally produced beehive coke. Although it had a very good CSR and CRI it was the only coke examined that cannot be used alone in a blast furnace because of its poor carburization characteristics. Production trials prove that this type of coke can only be used in a mixture with other more reactive coke.

4.6 Coke deadman

The coke “deadman” is a cone-shaped coke layer, located below the cohesive zone and beyond the active coke zone (Figure. 4.7). The coke in this zone comes from the coke charged into the center of the furnace. This coke is exposed to no or only very limited attack by carbon dioxide, and consequently its strength properties are not degraded. It maintains its size as charged more or less, affected only by slight abrasion on its way down through the furnace. So, coke lumps entering the deadman are bigger than those in coke layers more towards the wall. Some companies use stronger and/or larger coke in the center to enhance deadman permeability.

The main requirement for the deadman is to have sufficient porosity to ensure:

- From the level of the tuyeres upwards: unrestricted passage of both the gas from the raceway and sufficient permeability for the dripping iron and slag.
- From the level of the tuyeres downwards: sufficient permeability for slag and metal liquids on their way to the hearth.
- Within the hearth, below the taphole level: the deadman fills or at least mostly fills the furnace hearth sump. So, its permeability for hot metal and slag flowing towards the taphole determines the flow pattern of the liquids.

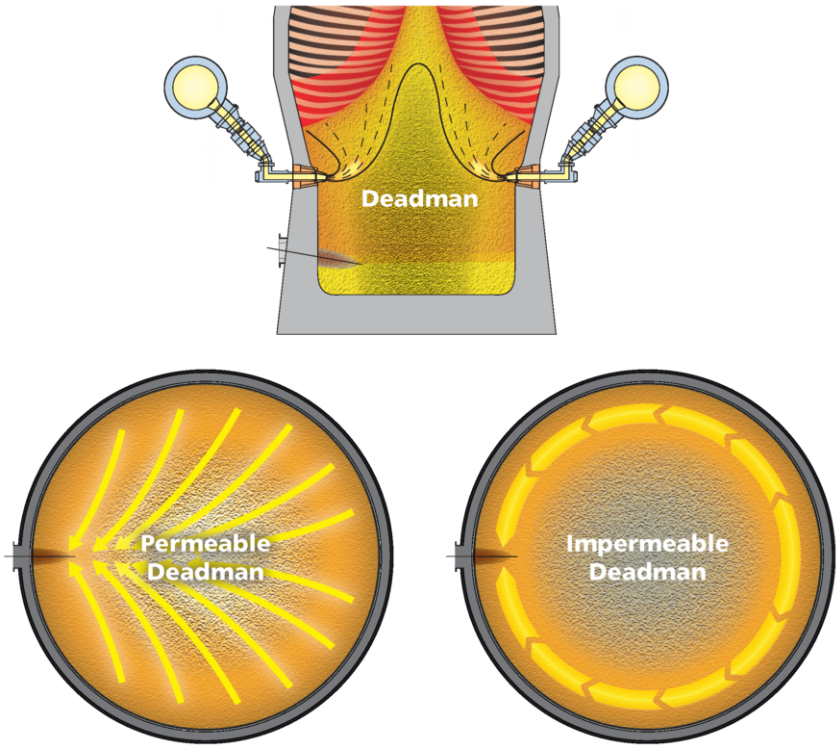

Figure 4.7 The coke deadman and the effect of a permeable deadman and impermeable deadman on hot metal flow lines towards the taphole

Figure 4.7 shows two patterns of hot metal flow in the hearth: flow through the deadman (left) and flow around the deadman (right). When the flow through the deadman is blocked, then the flow will take place along the wall of the furnace. This will lead to increased wear of hearth refractory lining and the hearth refractory reaches its end of campaign faster. Another possibility is for the deadman to float when it becomes dirtied. In this situation, a coke-free layer of limited depth will develop across the full furnace diameter, and within that layer flowlines for the metal towards the taphole will also be relatively direct. The tendency for the deadman to float is determined not only by its permeability but also by furnace geometry. Floating is more likely when the hearth sump is deep.

Example 4.2 Deadman cleanliness

Drainage capacity of the deadman can be quantified using a Deadman Cleanliness Index (DCI). The DCI is based on the observation that in the case of prolonged contact time between the metal and coke (both when dripping and when within the hearth pool), the carbon content of the hot metal approaches the saturation equilibrium value (Nightingale, 2000; Sergeant et al, 2005). The dirtier the deadman, the closer the approach to equilibrium becomes.

If, however, the deadman is clean, a high permeability coke bed allows faster passage of the metal, and less dissolution of carbon from the coke results in a greater (sub-saturation) departure from equilibrium carbon concentration in the metal. The calculated equilibrium value of carbon in hot metal can be estimated from the following formula:

$$\%C_{\text{sat}} = 1.3 + 2.57 \cdot 10^{-3} \text{HMT} - 0.31\%[\text{Si}] - 0.33\%[\text{P}] - 0.4\%[\text{S}] + 0.028\%[\text{Mn}]$$

The sub-saturation departure from equilibrium ΔC is calculated as follows, where the actual carbon value must be determined from metal:

$$\Delta C = \%C_{\text{sat}} - [\text{C}]_{\text{actual}}$$

If the difference between equilibrium and measured C is larger than 0.2 %, then the deadman is likely to be clean. If lower, then the deadman is likely to be “dirty” or less permeable. A value for real concern is below 0.1 %.

Some companies use the deadman cleanliness index (DCI). The DCI is determined from the following expression

$$\text{DCI} = \text{HMT} + \frac{1}{2.57 \times 10^{-3}} \Delta C - \left(1430 - 190 \times (1.23 - c/s) \right)$$

The last (bracketed) term recognizes the requirement for the deadman to allow drainage of slag as well as the metal. That term was formulated for the slag properties at Port Kembla, Australia and may not be strictly applicable to other sites. If in doubt about this, it may be safer to make evaluation on the basis of ΔC alone.

For furnaces having a volume from 2000 to 4300 m³, using natural gas injection and PCI, DCI varies within the range of 150–250 with the higher values resulting in better drainage capacity of the deadman.

As a result of carbon consumption and dissolution of coke ash in slag, coke lumps gradually decrease in size and are completely consumed. There is a slow and continuous replacement of coke in the deadman, which is supplemented with fresh coke descending from the top. Residence time of coke in the hearth is estimated to be about 2–3 weeks and depends on the blast furnace volume and performance.

The inactivation of the deadman (also called “dirty deadman”) can be identified from at least the following symptoms (Raipala, 2003):

1. Decrease of central temperature in the hearth bottom.
2. Hearth wall temperature increase.
3. Oxygen potential increase in slag (FeO and MnO in slag), resulting in poorer desulfurization of the hot metal.
4. Hot metal carbon decrease
5. Slag tapping ratio decrease
6. Hot metal temperature is higher than usual with the same energy consumption and hot metal composition
7. Shortening of the raceway can be observed
8. Shortening of the taphole length

Causes of inactivation of the deadman can be attributed to:

1. Coke properties: coke particles are exposed to mechanical stress in the stack and in the lower part of the blast furnace. Large and strong coke results in larger particle size and less fines in the hearth. Coke lumps are weakened in the stack by solution loss reaction ($C + CO_2 \rightarrow 2 CO$) and the impact on various coke qualities depends on its hot strength such as CSR/CRI.
2. Water leakage: Small leakages (tuyeres, cooling plates, stove circuits), especially when they remain undetected, may lead to an inactive deadman when water does not evaporate completely but seeks its way to cooler parts in the furnace bottom.
3. Maintenance stops (shutdowns): when the hot metal below the taphole level solidifies it has a large mass and good thermal conductivity to the cooled bottom. Excessive hearth cooling systems increase the risk of inactivation during blast furnace stop.
4. Low production rate: when the production rate is low, the residence time of coke in contact with CO_2 and alkalis increases and the coke properties weaken. Heat losses through the hearth lining are relatively constant at the beginning of the slow production period. Heat transport to the deadman slows down and risk of solidification at the bottom increases.
5. Hearth cooling: hearth cooling itself is an essential factor in problems with an inactive deadman. Because the clogged or dirty deadman is maintained by solidified matter, it requires cooling to keep the temperature below melting points.

Measures to activate a deadman include:

1. Increase the coke quality (no small coke in the burden).
2. Charge large size coke (larger than 60 mm) in center.
3. Increase coke rate and reduced PCI rate.
4. Reduction of hearth bottom cooling.

An example of deadman inactivation is shown in Figure 4.8, where a period with poor coke quality coincided with low values for the DCI. The effects were also visible in poorer casting behavior as well as higher sidewall temperatures.

1. Irregular coke quality (CSR)

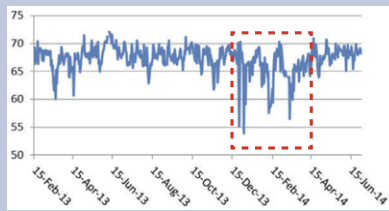

2. Not permeable dead man (DMI)

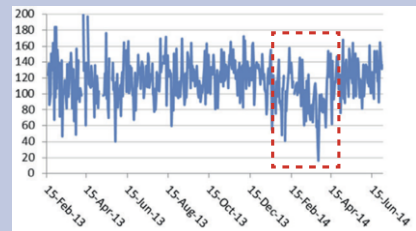

3. Difficult to cast slag from one side

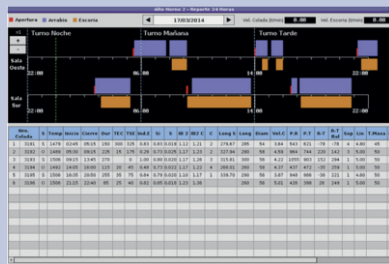

4. Hearth temperature differences

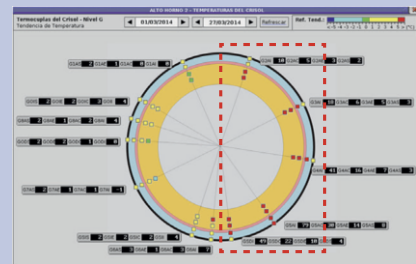

Picture shows the temperatures differences in a period of time (AT)

Figure 4.8 Poorer coke quality and effect on Deadman Cleanliness Index (DCI), showing increased sidewall temperatures and poorer casting on one taphole

4.7 Overview of international quality parameters

Figure 4.2 and Table 4.4 provide an overview of typical coke quality parameters and their generally accepted levels for a ‘good’ coke quality. Although not complete, the values given in the table represent coke qualities that have assisted in securing excellent blast furnace results over a long period.

	What is measured?	Results	Accept. Range	Best	Reference
Mean Size	Size Distribution	AMS mm HMS mm % < 40 mm % < 10 mm	40–60 35–50 < 25 < 2		
Cold Strength	Size Distribution after Tumbling	I_{40} % > 40 mm I_{10} % < 10 mm M_{40} % > 40 mm M_{10} % < 10 mm	> 45 < 20 > 80 < 7	60 16 87 5.5	Irsid Test Micum Test
	Stability at Wharf Stab. at Stockh. Hardness	% > 1" % > 1" % > ¼"	> 58 > 60 > 70		ASTM Test
Strength after reaction	CSR	% > 9.52 mm	> 58	70	Nippon Steel Test
Reactivity	CRI	% weight loss	< 29	22	Nippon Steel Test

Table 4.4 Acceptable range for coke quality parameters

Which is the most important quality parameter?

Different operators have their own preferences. A Russian ‘rule-of-thumb’ table gives a strong relationship between M_{10} , M_{25} and fuel rate and productivity (Danshin and Chernousov, 1989), whilst a German review (Grosspietsch and Lungen, 2000) demonstrates the impact of CSR on fuel rate, achievable PCI rate and productivity. Strong relationships have been observed between I_{10} and fuel rate. It can be argued that size, cold strength and hot strength are all important because they all impact on the permeability of the coke that is required for both liquid drainage and for efficient gas/solid contact, with I_{10} and CSR probably the two parameters most often cited as the most critical. Hearth voidage is more likely to be affected by CSR than I_{10} , because the fines generated by abrasion should be preferentially consumed by direct reduction and not reach the hearth.

With high PCI rate, the coke spends longer (more than 20 %) in the furnace above the raceway due to its slower consumption rate. It is therefore exposed to process conditions for longer. Once in the raceway, coke burns more slowly and tumbles around for longer, generating more fines, which are collected in the “bird’s nest”. Hence the need for coke of higher cold and hot strength to permit stable operation at high PCI rates.

Example 4.3 Consistency of coke quality, coke from stock

We have to stress that blast furnace operation is very much influenced by coke variability: the gas flow in the furnace can only be held consistent if the layer build-up is consistent and if day-to-day consistency of the coke is very good. There are, however, no international standards or criteria for day-to-day consistency.

The variability of coke quality has not been investigated in detail. Some companies use their own “fresh” coke and purchased coke. It is inevitable that even purchased coke with very good metallurgical properties behaves differently to in-house coke. Figure 4.10 shows “fresh” coke (left) and purchased coke. The purchased coke has suffered from abrasion and fine particles have disappeared. It looks more rounded. As will be described in the burden distribution section, the stockyard material will have different properties with respect to the angle of repose and also different flow characteristics from the top bin into the furnace.



Figure 4.9 Fresh coke and coke from stockyard compared

4.8 Coke, nut coke and high PCI

For cost-efficient operation the undersize of the coke after screening has to be reused. Some of the undersize can be used as coke breeze for sinter production, sometimes a small amount can be used for pellet production. The balance has to be efficiently used in blast furnaces (Dharm Jeet Gavel, 2020). Depending on the local situation, operators can choose to put more small coke in smaller furnaces, or screen coke at a smaller aperture in the smaller furnaces.

If the operational principle is that all coke produced at site has to be used at site, what is then the optimum for screening? An example is shown in Table 4.5, where the amount of coarse metallurgical coke is shown as well as the amount of nut coke in relation to the screening aperture.

size (mm)	> 125	> 100	> 90	> 75	> 63	> 50	> 40	> 35.5	> 30	> 25	> 20	> 10	< 10
fraction	0 %	0 %	1 %	4 %	7 %	17 %	24 %	17 %	13 %	8 %	6 %	2 %	1 %
kg/tHM			4	12	22	50	72	50	40	25	17	6	2
screen	40 mm	Metallurgical Coke: 70 %										Nut Coke: 30 %	
	35 mm	Metallurgical Coke: 83 %									Nut Coke: 17 %		
	30 mm	Metallurgical Coke: 91 %								Nut Coke: 9 %			
	25 mm	Metallurgical Coke: 97 %										Nut Coke: 3 %	

Table 4.5 Coke fractions and screening aperture; data are from an operating furnace and total coke rate, coarse and nut coke, is 300 kg/tHM

- With increasing screening aperture,
- the coarse coke layer becomes thinner,
 - the coarse coke layer becomes more permeable
 - more nut coke is generated, which has to be blended into the ferrous layers.

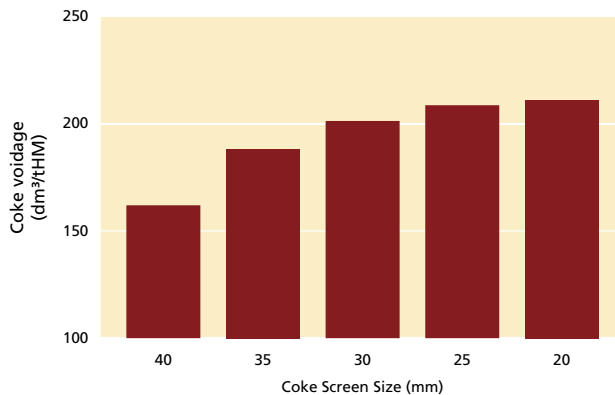

Figure 4.10 Coke voidage per tonne of hot metal (in dm³/tHM) increases with finer screening because of increased layer thickness

What is the optimum? Nut coke is very useful since it makes the cohesive zone more permeable for gas, but excess nut coke is not completely consumed in the furnace and will reach the hearth, thus worsening hearth permeability. So, nut coke has to be consumed at or above the tuyere level.

The melting of the ferrous burden requires that hot gas transfers its heat to the softening and melting materials, where it is mainly used to drive the direct reduction, and only a small part of the heat is used to heat up the materials. For this reason, gas permeability of the coarse coke layer in the cohesive zone is very important for melting. The thicker the coke layer per tonne of hot metal, the more voidage and the more permeable the cohesive zone (Figure 4.10).

At high PCI rates (over 200 kg/tHM) and low coke rates, the permeability of the coarse coke layer becomes critical, and so the nut coke should be at a reasonable level of 20–40 kg/tHM. In other words, if more nut coke is available, the coarser fractions should be considered coarse coke. Nut coke should also be distributed in the ferrous burden in the wall area because this part of the ferrous layer is more difficult to melt than –more inwardly located material. In addition, nut coke provides greater benefit because it improves gas permeability and melting. Moreover, if the nut coke is not fully consumed by direct reduction, it will probably be gasified at the tuyeres.

Example 4.4 Blast Furnace operation: redistributing nut coke to wall area

In a blast furnace (1880 m³ inner volume) nut coke was previously distributed over 30 % of the length of the ferrous burden on the conveyor belt. The nut coke was redistributed to reach the two outer rings with the ferrous burden. As a consequence, fluctuations of stove temperatures decreased as shown in Figure 4.11 before and after change to more nut coke in wall area. Similar results were observed for variation of cooling water temperatures, which correspond with heat losses (not shown).

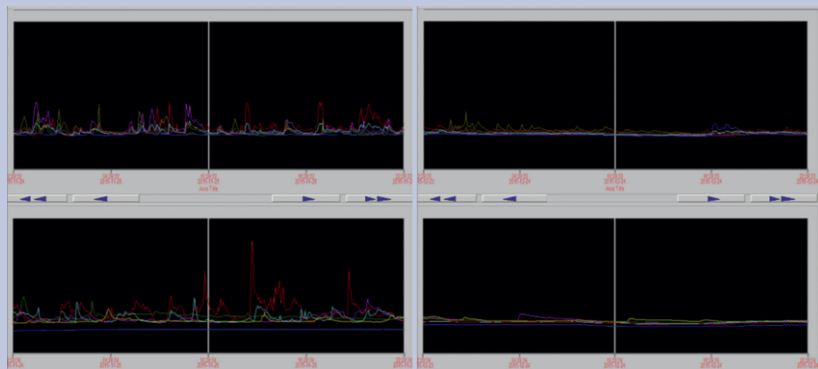

Figure 4.11 24 hour graphs of stove temperatures (rows 6 and 7) – nut coke being distributed in central area (left image) and wall area (right image)

V Injection of Coal, Natural Gas and Oil

The coke rate of a modern, big blast furnace operating with only coke as a reductant (fuel) is typically 500–520 kg coke per tonne of hot metal. The coke rate can be decreased by injection of coal, oil and natural gas (and other hydrocarbons), as was suggested already back in 1831 by John Samuel Davis. Use of natural gas injection started in 1957 in the Ukraine, with the technology spreading quite fast, especially in the USSR. Starting in the 1960s fuel oil injection was implemented, while industrial coal injection started at Amanda furnace in the USA in the 1960s. The technology of coal injection spread quite fast especially from the 1980s. The recent low cost of natural gas has led to the application of co-injection of coal and natural gas, especially in North America.

Since coke is a major part of the hot metal cost, use of injectants is economically attractive. Coke rates can be decreased by using injectants:

- By using coal injection, to 320 kg/tHM and even lower to 250 kg/tHM.
- By using natural gas: to 350 kg/tHM, but more typically about 400 kg/tHM.
- By using fuel oil: to about 375 kg/tHM.

The investments for using coal injection are considerable, while the investments for gas or oil injection are low. The relative price of oil is often too high to consistently be an attractive alternative.

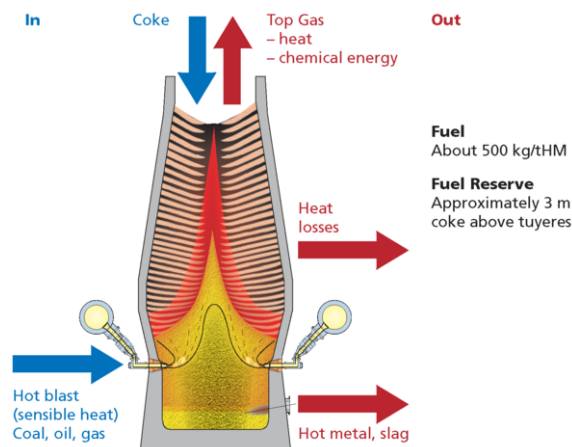

Figure 5.1 Schematic overview of energy inputs and outputs

The apparent versatility of the blast furnace for the use of various type of injectants comes from the fact, that in the raceway the temperatures are so high that the injectants and moisture are all converted to carbon monoxide and hydrogen within milliseconds after injection, and that the furnace “does not know” where the hydrogen and carbon monoxide are coming from.

5.1 Properties of coal, oil and gas

The energy inputs and outputs of the blast furnace are shown schematically in Figure 5.1. The major sources for energy in the furnace are the coke and injectants (coal, gas, oil), and the sensible heat of the hot blast. The main part of the energy is used to drive the change from iron oxides to iron and the other chemical reactions. The remaining energy leaves the furnace as top gas, as sensible heat of iron and slag and as heat losses to the cooling system.

The differences between the various injectants are based on their chemical composition. The carbon in the injectants becomes carbon monoxide (CO) and the hydrogen becomes molecular H_2 . So carbon content, hydrogen content and the presence of water and oxygen mainly determine the amount of heat generated in the raceway. When comparing the injection of coal (common), natural gas (less common) or oil (outdated), it is found that coal generates most heat: when burning coal with pure cold oxygen to CO and H_2 , it generates a flame temperature (T_{flame}) of around 2000 °C, while for natural gas this is around 850 °C (Table 5.1).

	T_{flame} (°C)	H_2 in gas	CO in gas
coal	~2000	25 %	75 %
natural gas	850	66 %	34 %
oil	1350	45 %	55 %

Table 5.1 T_{flame} and gas composition for incomplete combustion of coal, gas and oil to CO and H_2 (stoichiometric)

The generated heat is used in and below the cohesive zone to:

- Heat up and melt the material from where it starts softening, about 1200 °C, to casting temperature of 1500 °C.
- Remove the remaining oxygen from the ore burden and other hot metal components like silicon; this chemical reaction costs a lot of energy/heat and is called “direct reduction” (see Section 8.3.3).

The largest amount of energy (more than 80 %) is used for this direct reduction. However, the amount of direct reduction that has to take place also depends on the amount of hydrogen generated at the tuyeres, since hydrogen is very efficient in removing oxygen from the iron at high temperatures (900–1100 °C). As a consequence, the most important properties of injectants are: the amount of heat generated when gasified to carbon monoxide and the hydrogen content of

the gas (Table 5.2). Another effect is that the gas volume generated at the tuyeres increases when more hydrogen is present. This is shown as the gas volume generated by gasifying 1 kg of injectant with oxygen in Table 5.1. The amount of injectant needed to replace 1 kg of coke is indicated in the table as well as the effect of an additional 10 kg/tHM injectant on the flame temperature.

	C %	H %	Ash %	Heat MJ/kg	Gas m ³ STP/kg	RR kg/kg	T _{flame} °C
Coke	86.0	0.2	11.0	8.5	1.6	1.00	
Coal	80.0	4.4	8.8	6.7	2.0	0.88	-27
Natural Gas	72.6	23.5	0.0	2.3	4.0	0.97	-76
Oil	87.0	12.0	0.0	6.5	3.0	1.09	-46

Table 5.2 Properties of injectants: Heat of incomplete combustion to CO and H₂ of various injectants, gas volume generated (complete gasification with pure oxygen), replacement ratio (RR) relative to coke and T_{flame} effect if injection is increased by 10 kg/tHM. Estimated for the reference furnace.

The consequence is that the lowest coke rates can be reached with coal injection. Table 5.3 shows worldwide experience with different injectants, based on about 70 % of the maximum reached. Good, but not excellent, levels of injection are: 170–200 kg/tHM for coal, 80 kg/tHM for gas and 90 kg/tHM for oil. Note that when using natural gas, higher oxygen enrichment of the blast is required to keep the flame temperature in the required working area. The minimum annual average coke rate, which includes coarse metallurgical coke and nut coke, is 250–260 kg/tHM, of which at least 210–230 kg/tHM metallurgical coke, depending on slag volume (200–300 kg/tHM). The highest PCI rate reported is 252 kg/tHM (Lüngen and Schmöle). The maximum natural gas rate reported has been 130 kg/tHM, enabled by 9 % oxygen enrichment.

		All coke	Typical PCI	Max. PCI	Typical Gas	Max. Gas	Oil
Coke	kg/tHM	517	300	256	399	354	375
Coal	kg/tHM		200	252			
Oil	kg/tHM						90
NG	kg/tHM				80	130	
enrichment	%	0	6.1	9.1	7.1	11.1	3.1
Gas make	GJ/t	5.4	5.3	5.5	5.7	6.6	5.1
Stoves gas	GJ/t	1.9	1.8	1.6	1.7	1.6	1.9
Export gas	GJ/t	3.5	3.6	3.9	4.0	5.0	3.3
CV BF Gas	MJ/m ³ STP	3.1	3.7	4.1	4.0	4.6	3.5
Flame temp.	°C	2160	2200	2155	2145	1899	2210
Blast humidity	g/m ³ STP	40	12	12	12	12	12
Hot blast temp.	°C	1000	1200	1200	1200	1200	1200

Table 5.3 Typical operating conditions for different types of injectants

5.2 Coal injection

5.2.1 Coal injection: equipment

The basic design for coal injection installations requires the following functions to be carried out (Figure 5.2):

- Grinding of the coal. Coal has to be ground to very small sizes. Most commonly used is pulverized coal: around 60 % of the coal is under 75 μm (like powder). Granular coal is somewhat coarser with sizes up to 1 to 2 mm (like beach sand).
- Drying of the coal. Coal contains substantial amounts of moisture, from 8 % to more than 10 %. Since injection of moisture increases the reductant rate, moisture should be removed as much as possible.
- Transportation of the coal through the pipelines. If the coal is too fine or contains moisture, the pneumatic transport will be hampered. It may result in formation of minor deposits on the transportation pipe walls and also lead to coal leakage from the transportation pipes.
- Injection of the pulverized coal: Coal has to be injected in equal amounts through all the tuyeres. Particularly at low coke rate and high productivity, the circumferential symmetry of the injection should be maintained. Low injection rates (50 kg/tHM) at all tuyeres should be facilitated by the injection system. This is sometimes a problem with “dense-phase” coal injection systems.

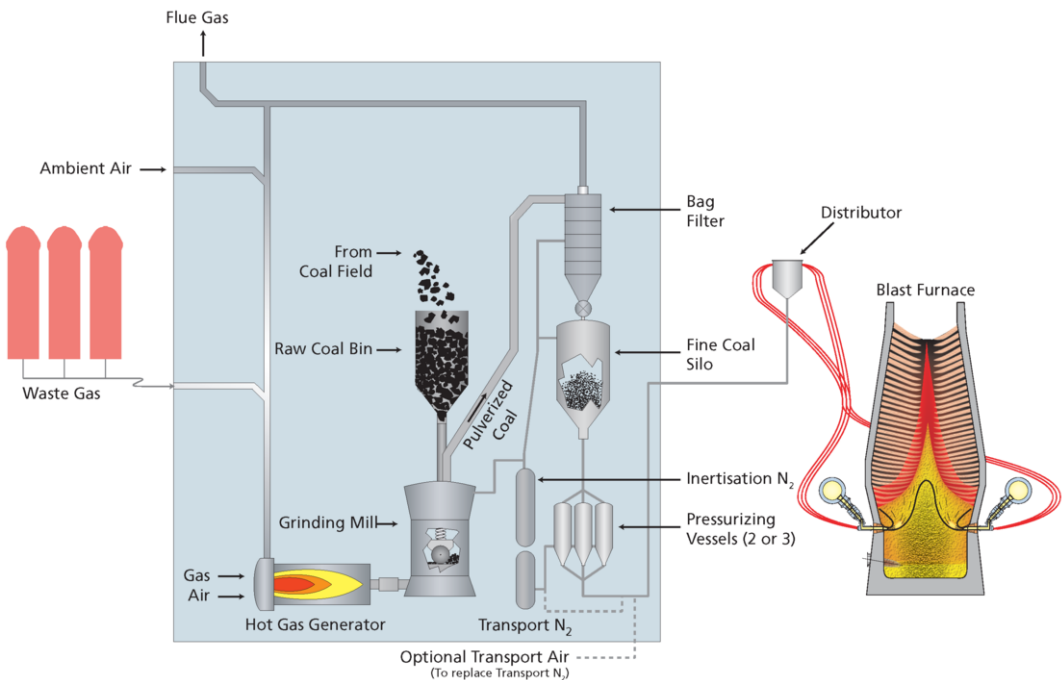

Figure 5.2 Example of PCI installation

There are various suppliers available for pulverized coal injection (PCI) installations. The reliability of the equipment is of the utmost importance, since a blast furnace has to be stopped within one hour if the coal injection stops.

5.2.2 Coal specification for PCI

Coke replacement

Coal types are differentiated according to their volatile matter content. The volatile matter is determined by weighing coal before and after heating for three minutes at 900 °C. Coals that have between 6 and 12 % volatile matter are classified as low volatile, mid volatile is 12–20 % in China and in different areas 12–30 %, while high volatiles are over 20 % in China and over 30 % elsewhere. All types of coal have been used successfully. The most important property of the injection coal is the “Replacement Ratio” (RR) relative to coke. The composition and remaining moisture content of the coals determine the amount of coke replaced by 1 kg of that type of coal. The replacement ratio of coal can be calculated with a mass and heat balance of the furnace. The chemical composition of the coal (i.e. carbon percentage, hydrogen percentage, oxygen content and ash content), the remaining moisture and the heat required to decompose or crack the coal chemical structure (especially the C–H bonds) have to be taken into account. Young coals contain relatively high O percentage, which means that the heating value of the coal is lower, since the CO bonds have already been formed in the coal structure. A simplified formula, provided by a coal supplier, for the replacement ratio is in Formula 5.1:

$$\begin{aligned} RR = & 0.998 \cdot C\%/100 + 2.217 \cdot H\%/100 - 0.077 \cdot O\%/100 \\ & - 0.067 \cdot N\%/100 - 0.073 \cdot (Q_{\text{crack}} \cdot (100 - \text{moist})/100) - 1.1 \cdot \text{moist}/100 \end{aligned}$$

where moist is the moisture content of the injected coal, and where RR is given as the amount of coke, with a C–content of 87.5 %, replaced by 1 kg of coal. The formula shows that coke replacement depends mainly on the carbon and hydrogen content of the coal. Any remaining moisture in the coal consumes energy introduced with the coal.

Cracking heat or the heat of decomposition is the difference between theoretical and measured calorific value. Accurate measurement of the calorific value is required to enable accurate determination. The following formula for the cracking heat (in MJ/kg) was generated from a large dataset of coal samples whose calorific value was measured using a high–quality bomb calorimeter.

$$Q_{\text{crack}} = 0.0007 \cdot VM^2 + 0.0126 \cdot VM - 0.3687 \quad (\text{if } Q_{\text{crack}} < 0 \text{ then } Q_{\text{crack}} = 0)$$

Cracking heat is generally accepted to represent the heat of dissociation of C–H bonds (MJ/kg) plus the heat of oxidation that is not realized due to the coal carbon having already reacted with oxygen. The higher volatile matter coals generally contain more oxygen.

Coal quality

Besides the carbon and hydrogen content, the most important parameters for coal quality to be injected are the following:

- Ash content and slag fusion temperature: the ash content of coal should be as low as possible, since it consumes high temperature heat of the raceway for heating and slag melting. Coal with high slag fusion temperature is helpful, because it is not easy to form scabs at the lance tip or inside a tuyere.
- Volatile matter: high volatile coals are easily gasified in the raceway, but have lower replacement ratio in the process.
- Composition: high sulfur and high phosphorus are likely to increase costs in the steel plant. These elements should be evaluated prior to the purchase of a certain type of coal. Young coals (high oxygen content) are known to be more susceptible to self-heating and ignition in atmospheres containing oxygen. This is also an important factor that must be considered with regard to the limitations of the ground coal handling system.
- Hardness. The hardness of the coal, characterized by the Hardgrove Grindability Index (HGI) must correspond to the specifications of the grinding equipment. The resulting size of the ground coal is also strongly dependent on this parameter and must correspond to the limits of the coal handling and injection system. The HGI is a measure of the fines < 74 μm (200 mesh) generated during a standard grinding test, with softer coals having higher HGI.
- Moisture content. The moisture content of the raw coal as well as the surface moisture in the ground coal must be considered. Surface moisture in the ground coal will lead to sticking and handling problems.
- Chloride content: The chloride content of coal can cause corrosion of the steel in the blast furnace gas cleaning system. Many blast furnaces use a coating inside the gas scrubber with a corrosion resistant paint or epoxy coating.
- Alkali (K_2O , Na_2O) content: The alkali in the coal for injection should be considered in the total alkali loading into the blast furnace, which is known to attack the refractory lining.

Potential injection coals can be evaluated on the basis of “value in use”, where all effects on cost are taken into account. It is often possible to use blends of two or three types of injection coals, so that unfavorable properties can be diluted (Section 5.2.4).

Coal types

There are many different types of coal. Among others, coals are characterized by the ash content and “volatile matter” content: the longer coals are left at high temperatures in the earth’s crust, the more volatiles escape.

The special aspect in a blast furnace is that the most valuable heat is generated by the “incomplete combustion” of coal to carbon monoxide (and hydrogen), while in a power plant the coal is combusted completely to carbon dioxide and water (H_2O). The carbon monoxide and hydrogen are used to reduce the oxygen content of the iron ore and are called “reductants”. Since in the lower part of the furnace we need heat (enthalpy) at a high temperature, the most appropriate

coals are the coals that have lower ash content, as well as lower oxygen content in the structure. This is because the fewer oxygen bonds with carbon that are present, the more heat is generated when forming carbon monoxide.

For heat generation, the better coals are low volatile, low ash coals. Table 5.4 compares HV (high volatile) and MV (mid volatile) coals for the reference furnace. MV have a higher replacement ratio. Productivity (at constant O₂ enrichment and ΔP) is ~2.5 % lower for high volatile coals, which can be compensated by increasing oxygen enrichment of the hot blast. The maximum production rate determined by maximum ΔP is equal for high and low volatile coals, although higher volatile coals require more oxygen enrichment.

High volatile coals (above 25 % VM) are easier to gasify in the raceway. For this reason, for many years, high volatile coals were the preferred coals, especially in Europe and the USA. Although experience in China shows that LV and MV coals can be used very efficiently.

		50/50 blend	HV	MV
Volatil matter	%	24	31	17
C	%	80.0	78.0	82.0
H	%	4.4	4.5	4.3
O	%	4.9	8.0	1.7
N	%	1.4	1.3	1.4
S	%	0.7	0.7	0.6
Ash	%	8.8	7.5	10.0
Q _{crack}	GJ/t	0.4	0.7	0.0
Moisture	%	1.0	1.0	1.0
Lower heating value	GJ/t	31.1	30.3	31.9
RR		0.86	0.82	0.91
T _{flame} (+10 kg coal/tHM)	°C	-26.6	-27.1	-26.1
Process Results Reference Furnace				
Production	tHM/d	12000	11845	12140
Coke Rate	kg/tHM	299.7	299.7	299.7
Coal rate	kg/tHM	200.0	210.6	190.4
O ₂ in blast	%	27.0	27.0	27.0
Top temperature	°C	150	159	143
T _{flame}	°C	2204	2165	2240
ΔP	bar	1.775	1.775	1.775
Max production at $\Delta P = 1.8$ and coke rate = 300 kg/tHM				
Production	tHM/d	12865	12870	12860
O ₂ in blast	%	30.05	30.8	29.4
T _{flame}	°C	2303	2282	2323

Table 5.4 High and mid volatile coals compared at constant coke rate and ΔP

Coal with a volatile matter content of 15–21 % can be considered. These coals can be comfortably injected into a blast furnace. If the VM content is lower than this, the coal is likely to be less reactive and so the rate of conversion may be insufficient. Coals with a VM below 6 % should not be used for this reason. Anthracites are very low VM coals, which fall into this category. They are very unreactive due to their more ordered carbon structure. Trials in the 1990s using a high proportion of anthracite experienced a significantly higher degree of coal carryover into the dust. It should be noted that the real volatile content of coals is 1.2 to 2 times the reported because the real heating rate and final temperature are much higher in the raceway than in the proximate analysis test, which was developed for coking and thermal coal evaluation.

Coal blending

Most companies use coal blends for injection. Blending allows for (financial) optimization of coal purchases. E.g. a company with a grinding mill for hard coals can use a considerable percentage of softer coals by blending them into hard coals. In doing so, an optimized value can be obtained. Blending dilutes the disadvantages of some coal types. Every material has disadvantages, like high moisture content, sulfur or phosphorus level, a relatively poor replacement ratio and so on. The blending can be done rather crudely. Depositing materials in the raw coal bin by alternating truck loads can be sufficient. Proper control of coal blend have to be put in place. In some blast furnaces, further cost reductions have been realized by blending lignite (brown coal), charcoal, petroleum coke or anthracite with the normal coal blends.

Research in coal gasification rigs has shown that when a high volatile coal is mixed with a low volatile coal, they combust more effectively than individually. A suggested mechanism is that the volatiles from the high VM coal are released first, combust around the low VM coal particles, and the thermal shock then helps the low VM coal to release its volatiles and combust. Different coals combust at different temperatures, times and rates. For this to be effective the coals must be well blended.

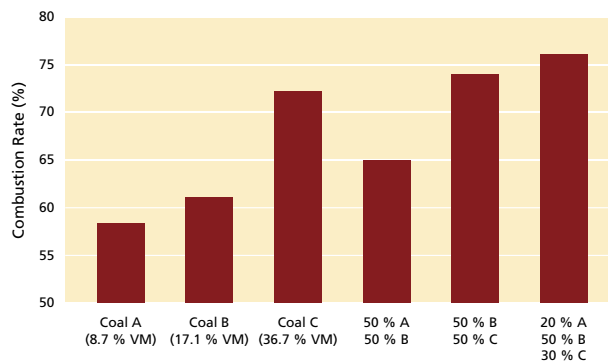

Figure 5.3 Effect of coal blending on gasification in a test rig (Santos Assis et al, 2004)

Figure 5.3 shows the rate of combustion of individual coals and blended coals (Santos Assis et al, 2004). These results were measured on a pilot scale test rig simulating a single tuyere. Others have noted that taking this to extremes can be detrimental because the high volatile coal can consume most of the oxygen meaning that burnout of the remaining low volatile coals will be low, which reduces their char reactivity.

5.2.3 Coal injection in the tuyeres

Coals are injected via lances into the tuyeres, then gasified and ignited in the raceway. The coal is in the raceway area only for a very short time (20–50 milliseconds – Steer et al, 2018), so the characteristics of the gasification reaction are very important for the effectiveness of a PCI system. Coal gasification consists of several steps as outlined in Figure 5.4. First, the coal is heated and the moisture evaporates. Gasification of the volatile components then occurs after further heating. The volatile components are gasified and ignited; this causes an increase in the temperature. All of these steps occur sequentially with some overlap.

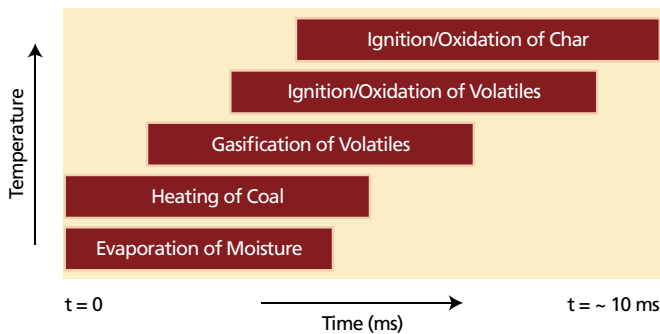

Figure 5.4 Coal gasification after injection

The effects of lance design, extra oxygen and coal type on the coal combustion have been analyzed. Originally, the coal lances were straight, stainless steel lances that were positioned at or close to the tuyere/blowpipe interface as indicated in Figure 5.5. Occasionally, very fine carbon (soot), formed from volatile cracking, is detected as it leaves the furnace through the top. To avoid this problem, especially at high injection rates, companies have installed different types of injection systems at the tuyeres, such as:

- Use of two lances per tuyere at different entry position or angles to cause more turbulence or better mixing with the blast. This approach is becoming more common with those operators aiming for very high PCI rates (> 220 kg/tHM).
- Co-axial lances with oxygen flow in an outer concentric pipe and coal flow in an inner concentric pipe.
- Lances with a tip specifically designed to cause more turbulence at the lance tip.
- Bent lance tips, positioned more inwards in the tuyere, closer to the tuyere nose.

The lance tip must be positioned at the center of the tuyere. If the coal impacts on the tuyere inside it can be damaged by abrasion. The lance tip must be in front of the blowpipe/tuyere interface to ensure that the coal does not burn in the blowpipe.

When using PCI, deposits of coal ash are occasionally found at the lance tip or within the tuyere. The deposits can be removed by periodic purging of the lance by switching off the coal while maintaining air (or nitrogen) flow.

The rate of gasification increases as:

- The volatility of the coals increases.
- The size of the coal particles decreases.
- The blast and coal are mixed better.

The gasification of coal also depends on the percentage of volatile matter (VM). If low volatile coals are used, a relatively high percentage of the coal is not gasified in the raceway and is transported with the gas to the active coke zone. This “char” will normally be used in the process, but might affect the gas distribution. The high volatile (HV, over 30 % VM) and ultra high volatile coal (over 40 % VM) produces a large quantity of gas in the raceway and a small quantity of char. So, higher VM coals cause a greater increase in blast momentum meaning that a stronger coke may be required.

If the gas combustion is not complete, soot can be formed. Blending a variety of coals, especially high and low volatile coals, yields the advantage of being able to control these effects. It has been found that the coke at the border between raceway and deadman contains more fines when working at (high) injection rates. This packed coke region has been termed the “bird’s nest” (Figure 5.5).

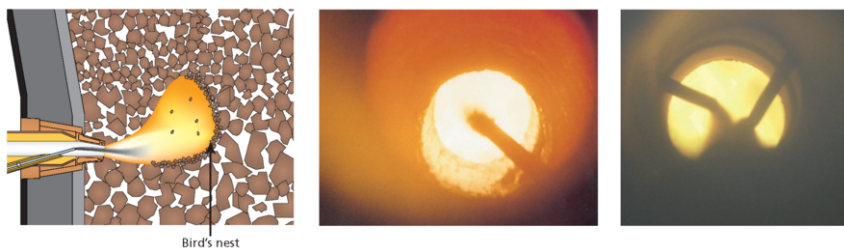

Figure 5.5 Coal injection in the tuyeres, single lance and double lances

5.2.4 Process control with coal injection: Oxygen and PCI

At high PCI operation, about 40 % of the reductant is injected via the tuyeres. For this reason, it is important to control the amount of coal per tonne of hot metal as accurately as the coke rate is controlled. The feed tanks of the coal injection system are weighed continuously, and the flow rate of the coal is controlled. It can be done with nitrogen pressure in the feed tanks, or a screw or rotating valve dosing system. In order to calculate a proper flow rate of coal (in

kg/minute) the hot metal production rate must be known. There are several ways to calculate this. The production rate can be derived from the amount of material charged into the furnace. Short-term corrections can be made by calculating the oxygen consumption per tonne of hot metal from the blast parameters in a stable period and then calculating the actual production from blast data. Systematic errors and/or the requirement for extra coal can be included in a process control model.

The heat requirement of the lower furnace is a special topic when using PCI. Coal is not only used for producing the reduction gases, but use of coal has an effect on the heat balance in the lower furnace. The heat of the bosh gas has to be sufficient to melt the burden. The heat requirement of the burden is determined by the “pre-reduction degree”, or how much oxygen still has to be removed from the burden when melting. The removal of this oxygen requires a lot of energy. The “melting capacity” of the gas is defined as the heat available with the bosh gas at a temperature over 1500 °C and depends on:

- The quantity of tuyere gas available per tonne of hot metal. Especially when using high volatile coal there is a high amount of H₂ in the bosh gas.
- The flame temperature in the raceway.

The flame temperature itself is determined by coal rate, coal type, blast temperature, blast moisture and oxygen enrichment. From the above, the oxygen percentage in the blast can be used to balance the heat requirements of the upper and lower furnace. The balance is dependent on the local situation. It depends on burden and coke quality and coal type used. For the balance there are some technical and technological limitations, which are presented as an example in Figure 5.6.

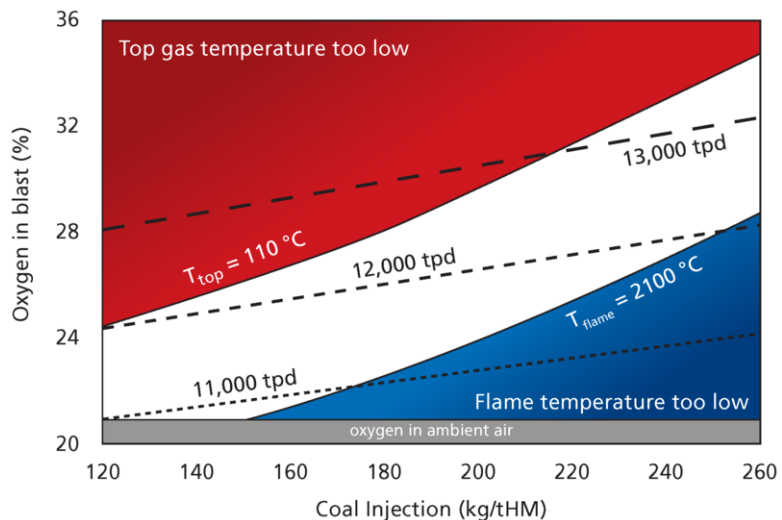

Figure 5.6 Working area (white) showing limiting factors with coal injection as calculated for a ΔP of 1.8 bar

For higher injection rates more oxygen is required, but this has to remain within the limits of the working area, which is the area between a minimum top temperature and a minimum T_{flame} .

- Minimum top gas temperature: If the top gas temperature falls too low, it takes too long for the burden to dry and the effective height of the blast furnace shortens. Deposits of wet dust particles in the first stage of gas cleaning (dust catcher or cyclone) can result in plugging of the dump valves.
- Minimum flame temperature: Low flame temperature will hamper coal gasification and melting of the ore burden. In Figure 5.5 (next page), 2050 °C is used as the minimum flame temperature.

Further restraints have to do with maximum flame temperature and technical limitations. If the flame temperature rises too high, burden descent can become erratic. Technical limitations are for instance the allowed or available oxygen enrichment in the plant's oxygen production facility or pipeline size or pressure.

The higher the oxygen injection, the higher the productivity of the furnace can be, as shown in Figure 5.6, which is based on the mass and heat balance of the reference furnace. The highest productivity is reached, with an oxygen level set so that the top gas temperature is at the minimum. The minimum is the level where all water of coke, burden and process is eliminated from the furnace, i.e. slightly above 100 °C. From a technological perspective it can be said, that the heat balances over the lower part of the furnace (i.e. from 900 °C to tuyere level) and over the upper part of the furnace (i.e. from top to the 900 °C isotherm) are in balance (Section 8.5). In operational practice the availability of oxygen in a plant is often the limiting factor. Sometimes “unburnt coal” is observed in top gas. In Example 5.1, coal gasification is discussed. Besides incomplete coal gasification, char can be observed in top gas, leading to black foam on the water treatment plant for the following mechanisms:

- Unburnt material can be found in periods with poor burden descent. Our explanation is that in these situations channeling of the gas flow from tuyere to top takes place.
- High coal injection requires a central coke chimney and results in high top gas temperatures in the center of the furnace. A possible explanation for some of the “char” found at the top is Boudouard carbon (solution loss reaction), formed when the central high temperature (over 800 °C) of the top gas with a high CO percentage cools down over the temperature range where the Boudouard reaction takes place.

5.2.5 Effect of additional PCI

The effect of the use of extra coal injection for the recovery of a cooling furnace is three-fold. By putting extra coal on the furnace:

1. the production rate decreases, because the production rate is determined by the amount of coke gasified by the hot blast;
2. the flame temperature drops;
3. the gas reduction increases by increased H_2 content in bosh gas, and thus direct reduction decreases.

Responses 1 and 2 are fast and are only delayed by the response time of the hearth heating up – so two to three hours. Response 3 is slower, because the cohesive zone has to be processed before it becomes effective, and response will take an additional 2–3 hours. A furnace recovers from a cold condition by increasing PCI, because it slows down the production rate, because the coke burning rate decreases. If simultaneously T_{flame} is kept constant, there is even more heat per tonne available to melt the ferrous burden. If the effect of hydrogen is taken into account, which reduces direct reduction and therefore the heat required for melting, the effect becomes even more pronounced. For daily operations: remedial action for a cooling trend is:

- to use additional PCI
- at constant T_{flame} and
- constant (or decreasing) hot blast oxygen input per hour.

Example 5.1 Gasification of injected coal

Coal is not completely gasified in the raceway. Some material leaves the raceway as char. Observation of “un-burned char” at the top has led to numerous investigations with respect to coal gasification. At high coal rates, an estimated 30 % of injected coal leaves the raceway as char. In most situations only very small amounts of char leave the furnace with top gas. So, most char is used in the process, most likely by its use in direct reduction reactions or by adhering to coke. Char is much more reactive than coke; so will preferentially be consumed at high temperature by Boudouard reaction with CO_2 to form CO. There is no standard test for char reactivity. One test reported (Steer et al, 2018) uses 100 % CO_2 at 900 °C and measures the time taken for 50 % of the reactive portion of the char to be consumed. Chars were produced in a drop tube furnace (DTF) and tested by this method. The results show that char from LV coal is less reactive than char from HV coal. In general, coals with a higher burnout (proportion of carbon burnt in the drop tube furnace), generate a more reactive char, and HV coals yield better burnout. For an individual coal, the longer the residence time in the DTF, the higher the burnout, but the poorer the char reactivity.

There is debate over the factors affecting char reactivity. Char morphology influences the reactivity due to its effect on available surface area for reaction. The internal surface area available for reaction may be increased by the presence of large ‘feeder pores’ at the char surface (Hippo & Walker, 1975). The char pore structure is not determined by the original coal porosity (Yu et al, 2007). Swelling, fragmentation and agglomeration all impact available surface area. It is also reported that ‘reactive sites’ within the pores affect the intrinsic reactivity (Bar-Ziv and Kantorovich, 2007; Gupta et al, 2006).

Higher ash coals, particularly those predominantly formed from aluminosilicates, can inhibit burnout in the raceway by the molten ash encapsulating organic material, thereby inhibiting its availability for reaction.

5.2.6 Effect of a tuyere without PCI injection

At many operating furnaces one or more tuyeres are not injecting PCI. What occurs in the blast furnace?

Suppose that all tuyeres accept the same hot blast volume per hour. In one tuyere no coal is injected, but the same amount of hot blast as in its neighboring tuyeres. At this tuyere, only coke will burn, leading to an increase in coke burning rate (= production rate) and a strong increase in T_{flame} . The coal will be divided over the other tuyeres, which decreases the local coke burning rate (= production rate) and T_{flame} . This is shown in Figure 5.8 and results are given Table 5.5. The cohesive zone becomes asymmetric. Missed coal injection coal into a tuyere becomes more serious at higher injection rate. If more than one tuyere is not on coal injection, the situation is more severe, when they are located close to each other.

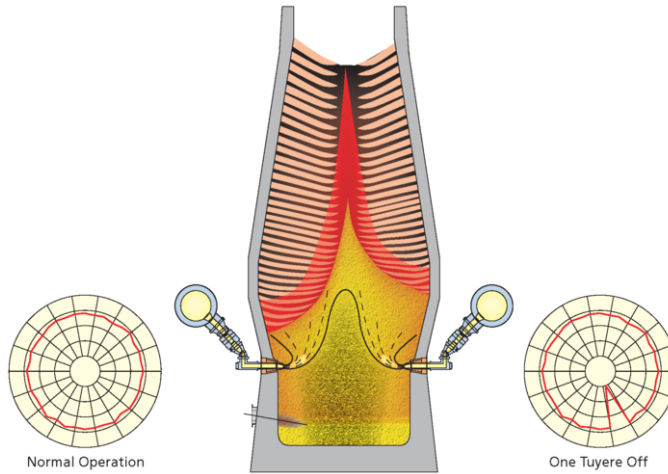

Figure 5.8 Tuyere without PCI and its effect on cohesive zone

		base	39 tuyeres on coal	1 tuyere without coal
Production	tHM/d	12000		
Tuyeres		40	39	1
Production	tHM/h.tuyere	12.5	12.1	29.7
T_{flame}	°C	2200	2187	2732
Production rate	tHM/h.tuyere	12.5	12.1	29.7
Production rate	% of basis	100	96	238

Table 5.5 Process effects when there is no coal injection on a tuyere

Example 5.2 Coal backing up

With coal injection, it is very important that the tuyeres are clear and open, allowing the coal plume to flow into the raceway to optimize combustion. If the tuyere should become blocked, or a blockage in front of the tuyere appears, injection must be stopped immediately. If it is not, the coal will flow backwards into the tuyere stock and can ignite further up in the connection with the bustle pipe (Figure 5.9). This can cause serious damage or even explosions. It is especially prone to happen within an hour after restart of a furnace, since unmolten material can block the tuyere gas flow. The phenomenon has also been observed with natural gas injection. In many cases this has been a cause of a chilled hearth since the furnace is shut down in an unprepared state for extended periods to replace tuyere stock or repair the bustle main.

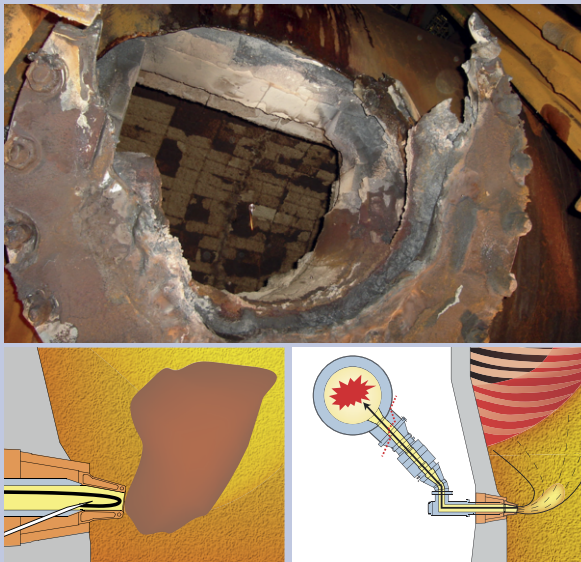

Figure 5.9 Coal (or natural gas) backing up into the bustle pipe, caused by scab in front of tuyere, leading to the possibility of explosion. The upper picture shows the damage at the hot blast main.

To prevent an incident, a light sensor may be fitted in front of the peepsight to detect a blockage at the end of the tuyere, or the ΔP can be measured over the tuyere stock to detect gas flow into the furnace. If there is no flow, this indicates that a blockage is present. The coal to that tuyere is automatically switched off and restarted only once an operator has checked the tuyere. Many furnaces using natural gas injection rates over 90 kg/tHM are also installing the ΔP blocked tuyere detection to shut off the natural gas to prevent back-ups. Tuyere cameras allow the operator to monitor blockage from the control room.

5.3 Natural gas injection

Natural gas typically consists of methane with some minor quantities of other hydrocarbons and nitrogen. Most frequently, natural gas injection is applied in the range of 60–90 kg/tHM, although higher levels have been reached up to 150 kg per tonne of hot metal (Agarwall et al, 1999) or on other furnaces more than 100 kg natural gas per tonne of hot metal (see e.g. Lingiardi et al, 2001). The replacement ratio of natural gas is typically 1–1.1 kg coke/kg natural gas and the replacement ratio is non-linear, so decreases as the natural gas rate increases. This happens especially above 80 kg/tHM because the water content of top gas increases, and the gas volume decreases because of the high level of oxygen enrichment required.

5.3.1 Injection systems for natural gas

Natural gas injection is mostly into the tuyeres with one lance per tuyere, but it can also be injected through a port in the tuyere copper casting sidewall. Natural gas is injected into the tuyeres at ambient temperatures and is gasified in the tuyeres. The residence time of the gas in an oxidizing atmosphere of the raceway is very short: 4–7 milliseconds. Some companies apply premixing of gas and oxygen and injecting it with gas–oxygen mix lances aimed at complete combustion in the raceway.

In order to keep the natural gas rate constant on the basis of kg natural gas per tonne of hot metal, the production level of the furnace has to be constantly monitored and calculated, so that the total flow control can be adjusted in real time. The control system of natural gas normally is based on a flow measurement and control valve for injection in every tuyere.

In contrast to PCI, an injection system for natural gas is relatively simple and requires limited investment.

5.3.2 Process control with natural gas

As in Figure 5.6 for coal injection, the working area for natural gas and oxygen enrichment is shown in Figure 5.10. When using natural gas, the minimum T_{flame} (for example 2050 °C) and minimum top gas temperature cross each other; this will be the point with the highest possible productivity and lowest coke rate. The exact position of the crossing point depends on local conditions (like moisture input with burden and coke) and on the minimum possible flame temperature. Fortunately, because of the hydrogen effect, the minimum T_{flame} with gas injection is lower than with coal injection; this is shown with the flame temperature of 2000 °C in Figure 5.10, resulting in a potential higher gas injection rate of about 20 kg/tHM.

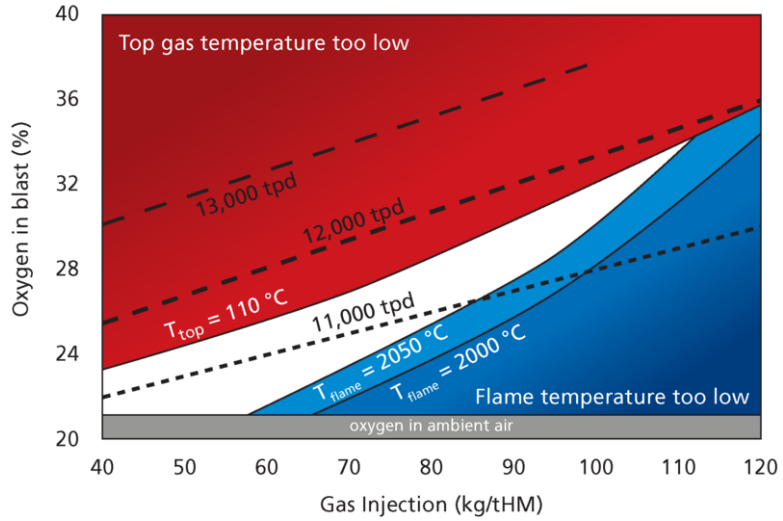

Figure 5.10 Working area (white) for a furnace on natural gas injection

5.3.3 Natural gas and thermal control

The usability of coal-injection for thermal control is based on the fact that, as soon as the coal injection rate is increased, the production slows down, which compensates the effect of the lower flame temperature. Natural gas works much slower in the furnace: the immediate effect of increase in natural gas injection is that the flame temperature drops three times more than with coal, while the production rate decreases slower than with PCI. Natural gas works more indirectly by changing the reduction reactions. Additional coal injection works immediately and is visible in the casthouse after 3–6 hours. For additional gas injection the effect of, for example 10 kg, natural gas is smaller, and the reaction is further delayed by 2–3 hours.

5.3.4 Flame temperature, hydrogen and total energy approach

The adiabatic flame temperature reflects the heat which is used to melt and heat up the hot metal and slag, as well as the heat used in the final reduction of oxides. As shown above, the flame temperature effect of natural gas is much larger than that of coal, oil or tar. However, the decrease in direct reduction reaction means that less heat is required for the final melting and heating. Furnaces operating with natural gas can operate on lower flame temperatures. Furnaces operating with coal injection typically operate in a range of flame temperatures of 2050–2200 °C, while furnaces with natural gas can operate at flame temperatures well below 1900 °C. The effect is caused by the relatively large percentage of hydrogen in natural gas. It is discussed here, but equally well applicable for hydrogen coming from other sources (coal, oil and moisture in hot blast).

The hydrogen is generated by the incomplete combustion of natural gas and partly replaces the carbon monoxide. Hydrogen is very efficient for reduction in the lower part of the furnace. The presence of hydrogen in the bosh gas lowers the direct reduction, and gas reduction in the shaft increases. So, higher hydrogen in the bosh gas lowers the heat requirement of the lower part of the furnace. This approach has been quantified by Charles River associates (Agarwall et al, 1991). The basis of their approach is that the hydrogen effect is recalculated to a lower heat requirement for the lower furnace.

The total energy is the thermal energy plus the “chemical” energy. The thermal energy is the amount of heat generated in the raceway above a reference temperature of 1482 °C (= 2700 °F). So, it is the gas quantity (m³ STP/tHM) times (T_{flame} - 1482) times the heat capacity of the gas (kJ/m³ STP). The chemical energy is the equivalent energy of the bosh gas hydrogen and the hydrogen utilization, taking into account that additional gas reduction by hydrogen gives an energy advantage of 132 MJ/kmol FeO. This is based on the following reaction equations:

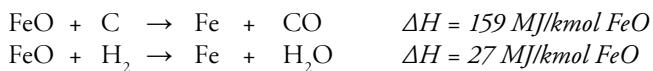

The difference is 132 MJ/kmol FeO, the total energy is the sum of thermal and chemical energy. Analysis of an operating blast furnace at varying gas rates has shown that the total energy required in the lower furnace is constant (Lingiardi et al, 2001). This means, that at higher gas injection rates and thus higher hydrogen input per tonne, the chemical energy increases allowing the thermal energy (T_{flame}) to decrease.

But hydrogen has other effects on the process. Firstly, since hydrogen is a very light molecule, the density of the blast furnace gas decreases with increasing hydrogen content and more wind can be blown for the same ΔP. This can be quantified as follows. The Ergun equation is

$$\Delta P/L = K\rho v^2$$

where ΔP/L is the pressure difference per unit height – and is related to burden properties, permeability index (K), the gas density (ρ) and the gas speed (v). For 5 % more hydrogen in the bosh gas, the density decreases by 4.3 % and the blast volume can increase by 2.3 % for the same ΔP.

Secondly, since part of the reduction process is done with hydrogen, the requirement for carbon monoxide decreases. The amount of carbon – the carbon footprint – required per tonne of hot metal decreases. The difference is that the carbon requirement for a furnace on natural gas is 10–15 kg lower than for a furnace with coal injection, when we neglect any coke effects.

Third, standard deviation of hot metal silicon and sulfur decrease with increasing injection levels. This is ascribed to the observation that the variability in direct reduction is largely responsible for the variability of the thermal state of the blast furnace.

It should be noted that even though the additional hydrogen produced by high natural gas injection (above 100 kg/tHM) improves the process, as described above, the top gas hydrogen can be between 10–14 %, which is highly flammable. For this reason, the furnace top and charging equipment must be maintained free from leakage, or a top fire could result when mixed with oxygen in the outside air.

5.4 Coal-gas co-injection

Depending on the local situation, operators choose to co-inject coal and gas simultaneously, especially in North America. Co-injection can be done by using two lances per tuyere as shown in Figure 5.11.

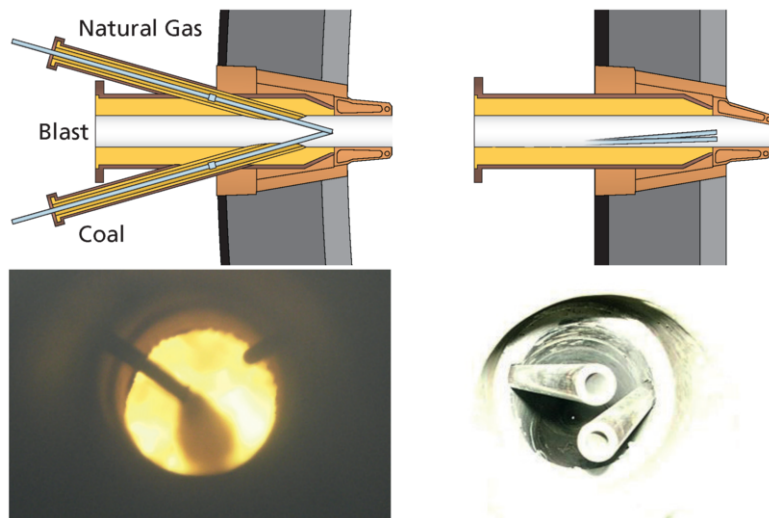

Figure 5.11 Through the peepsight: co-injection of coal and natural gas

Figure 5.12 shows the annual average operating results of North American blast furnaces over 2016, with 14 furnaces co-injecting coal and natural gas. Typically, tonne of hot metal about 20–40 kg natural gas and 125–160 kg coal are used per tonne of hot metal.

Since in the raceway, the gas and coal are (nearly) completely converted to CO and hydrogen, the effects of both injectants are additive. Coal still generates the most heat, while gas generates hydrogen, which is efficient in the lower part of the furnace. In comparing the operating furnaces, it was found that in some furnaces the amount of coal replaced by natural gas was significantly higher than that calculated from models. This is probably due to the fact that direct reduction is lower when using natural gas. As a consequence, the furnace becomes thermally more stable, which allows the operator to work on a lower thermal level (Geerdes, 2016).

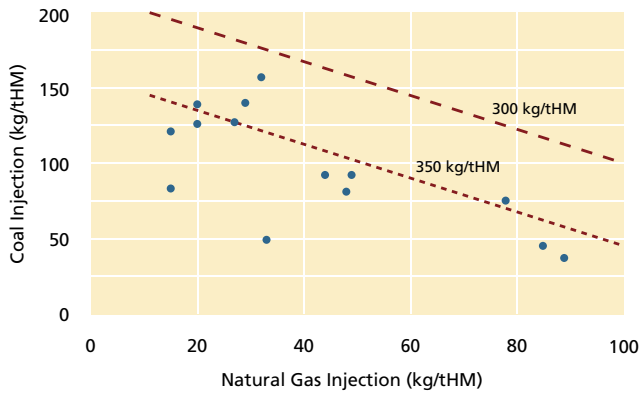

Figure 5.12 Co-injection of natural gas and coal in North American blast furnaces. Dotted lines indicate coke rates.

VI *Blast Furnace Gas and Processing the Ferrous Burden*

6.1 Introduction

The blast furnace is charged with pellets, sinter, lump ore and coke, while additional reductant (pulverized coal, natural gas) can be injected through the tuyeres. The steel plant requires a defined quality of hot metal and the slag chemistry has to be designed for optimum properties with respect to liquidus temperature, fluidity, desulfurising capacity, alkali removal and slag markets. For this reason, the blast furnace operator has to make calculations to select the blast furnace burden. The present chapter first details the conditions for a burden calculation, which is then illustrated with a practical example. Then it is shown how and where the gas processes the ferrous burden. In order to aim for maximum productivity, the permeability for gas and efficiency of the process have to be understood. Finally, a furnace is efficient if every tuyere contributes the same amount to the process. So, circumferential symmetry is of major importance, while the blast furnace process is very asymmetric in the radial direction. An important lesson from this chapter is that in a blast furnace the local temperature determines the progress of the chemical reactions. Understanding blast furnace operation is about understanding heat transfer and to a much lesser extent understanding chemistry.

6.2 Hot metal and slag composition

6.2.1 Hot metal and slag quality objectives

- Starting points for burden calculations are the hot metal and slag quality.
- Hot metal quality: hot metal contains around 94.5 % iron (Fe), some 4.5 % carbon (C), 0.4–0.6 % silicon (Si). Low sulfur (S, under 0.03 %) and defined phosphorus (P) levels, typically ranging from 0.05 to 0.13 %, which depends on the phosphorus content of the burden materials. The balance consists of manganese (Mn) and a number of different elements including titanium.
 - Slag quality: generally, the lower the slag volume the better. Typically, the four major constituents of slag represent some 96 % of its volume: Al_2O_3 (8–20 %), MgO (6–12 %), SiO_2 (28–38 %) and CaO (34–42 %). For slag design, see Chapter VIII.

Example 6.1 Burden Calculation

The composition of burden components and their distribution over hot metal and slag can be calculated with a one-stage mass balance. The present example is restricted to the components required to calculate the slag composition. The four main components (SiO_2 , CaO , MgO and Al_2O_3) represent 96 % of the total slag volume. The remaining 4 % consists of MnO , S , K_2O , Na_2O , TiO_2 and many more. Yield losses when charging the furnace, have to be taken into account for operation, but are left out here. Yield losses collect in the dust catcher and gas scrubber systems.

The calculation is done as follows. The targets for the calculations are taken; in most models the basicity, either the 2 or 3 components basicity are chosen. In this example, a B2 basicity (CaO/SiO_2) of 1.15 is used. The chemical analysis of the input materials is shown in the upper part of the table. The quantities of the various materials are used to make 1 tonne of hot metal, which contains 945 kg of Fe. In the example 70 % sinter, 20 % acid pellets and 10 % lump ore are used. The final burden is calculated in an iterative process, where more elements are considered and more restrictions can apply: for instance with respect to the slag Al_2O_3 or MgO content as well as with respect to the input of different materials like alkali and zinc.

Chemical Analysis (weight %)	ash	Fe	SiO_2	Al_2O_3	CaO	MgO
coke	11.0	0.5	5.5	3.3		
coal blend	8.8	0.5	4.4	2.6		
sinter		58.3	4.6	1.0	8.9	1.8
pellets		65.0	4.0	1.4	0.5	0.3
lump		62.0	5.0	1.8		
Slag Analysis (per tHM)	kg/tHM	Fe	SiO_2	Al_2O_3	CaO	MgO
coke	300	2	17	10	0	0
coal blend	200	1	9	5	0	0
sinter	1099	641	51	11	98	20
pellets	314	204	13	4	2	1
lump	157	97	8	3	0	0
Total	1570	945	96	33	99	21
Hot metal Silicon (0.46%)			-10			
In slag	kg/tHM		86	33	99	21
Results			SiO_2	Al_2O_3	CaO	MgO
slag composition	%		34.5	13.3	39.8	8.3
slag rate*	kg/tHM	250				
B2, CaO/SiO_2		1.15				
B3, $(\text{CaO}+\text{MgO})/\text{SiO}_2$		1.39				

Table 6.1 Calculation of slag composition (starting points in Annex II)

The burden has to fulfil requirements with respect to the highest allowable input of:

- Phosphorus – since phosphorus leaves the furnace with the iron.
- Alkali input – sodium (Na_2O) and especially potassium (K_2O), which can attack the refractory and affect the process. Typically, a limit of 1 to 3 kg/tHM is used.
- Zinc: zinc can condense in the furnace and can, similar to alkali, lead to a zinc cycle. Limits for zinc input are typically 100–150 g/tHM. With high central gas temperatures, zinc and alkali are partly removed with the top gas.

6.2.2 Burden calculation for slag composition

The burden calculation uses the chemical composition (on a dry basis) and the weights of the various materials in a charge as input parameters, usually expressed per tonne of hot metal. A charge consists of a layer of burden material and a layer of coke with its auxiliary reductants as injected through the tuyeres. The mass balance consists of the input and output of the iron and slag components (SiO_2 , CaO , Al_2O_3 , MgO), as described in Example 6.1.

6.3 Top gas composition from a one-stage mass balance

The blast furnace process is driven by blowing hot blast into the furnace that gasifies coke and injectants. So, shortly after the raceway, the gas temperature (T_{flame}) is high (2200 °C); bosh gas consists of nitrogen (N_2), carbon monoxide (CO) and hydrogen (H_2). The gas heats and reduces the ferrous burden. The overall balance of the gas is presented in Example 6.2 on the next page. Details of what happens inside the blast furnace are discussed in Section 6.6.

The top gas in the blast furnace is formed as follows.

- Nitrogen (N_2): the major source of nitrogen is the hot blast. Nitrogen is inert in the furnace and escapes from the charged burden 6–10 seconds after it has been blown in.
- Carbon (C), contained in coal and coke, that is used in the process for chemical reactions and for dissolution of carbon (around 4.5 %) in the hot metal. The balance of the carbon leaves the furnace with the top gas.
- Oxygen (O_2): oxygen is blown into the furnace with the hot blast and is charged with ferrous burden. Some minor quantities of oxygen are contained in the coal and in moisture in wind and injected coal. Oxygen leaves the furnace with the top gas, again as CO and CO_2 and as water (H_2O) formed in the process of reduction of the burden with H_2 .
- Hydrogen (H_2): the major source of hydrogen is the fuel injection, with minor amounts coming from moisture in the hot blast and coal. The water charged with the burden and coke is not considered, because it evaporates before the blast furnace process starts.

Example 6.2 One-stage gas balance of a blast furnace

The balance can be used to estimate the bosh gas composition as well as the top gas utilization. It is made up as follows based on the input data on the next page:

- Count all inputs of oxygen, carbon, hydrogen and nitrogen together in kmol per tonne of hot metal.
- Subtract the amount of carbon in the hot metal. The balance is eliminated with the top gas.
- Part of the hydrogen is used for reduction of the ferrous burden generating H_2O . Typically, hydrogen utilization is 40 %.
- The result is an amount of nitrogen and hydrogen in the top gas (in kmol), as well as an amount of kmol C and O. Since every CO contains 1 atom O per C and CO_2 contains 2 atoms O per C, the amount of CO_2 is kmol O minus kmol C, as illustrated in the table below.
- With CO and CO_2 available, the gas utilization ($CO_2/(CO+CO_2)$) can be calculated.

Input tuyeres (per tHM)			kmol N_2	kmol H_2	kmol C	kat O	kmol Fe
wind	m^3 STP/tHM	900	29.9			21.7	
moisture in wind	g/m^3 STP	12		0.6		0.6	
coal	kg/tHM	200	0.1	4.4	13.3	0.6	
coal moisture	kg/tHM	2		0.1		0.1	
Input tuyeres	per ton HM		29.4	5.1	13.3	23.0	
Input top							
coke	kg/tHM	300	0.1	0.3	21.5		
burden	kg/tHM	1570				24.6	16.9
Total			29.6	5.4	34.8	47.7	16.9
Output taphole							
hot metal	kg/tHM	1000			-3.8		-16.9
slag	kg/tHM	250					
Output top gas							
		total	kmol N_2	kmol H_2	kmol C	kat O	
H ₂ eliminated as H ₂ O				-2.2		2.2	
top gas (minus H ₂ O)			29.6	3.2	31.1	45.5	
top gas (composition)			N_2	H_2	CO	CO_2	H_2O
	kmol/tHM		29.6	3.2	16.7	14.4	2.2
	%		46.3	5.1	26.1	22.6	
	m^3 STP/tHM	1431	662	73	373	323	48
	kg/tHM	1935	828	6	467	634	39
η_{CO}			46.4 %				

Composition			Fe	C	H	O	N	moist	ash
coke	kg/tHM	300		86.0	0.2		1.3		11
coal	kg/tHM	200		80.0	4.4	4.9	1.4	1	8.75
hot metal	kg/tHM	1000	94.5	4.5					
slag	kg/tHM	250							
Operating conditions									
wind volume	m ³ STP/tHM	900							
O ₂	% in wind	27							
blast moisture	g/m ³ STP	12							
coal moisture	%	1							
utilization H ₂	%	40							
O/Fe burden	atom/atom	1.46							
1 kmol gas	m ³ STP	22.4							

Table 6.2 Gas balance in the blast furnace

6.4 The temperature profile and chemical reactions

The temperature profile and the chemical reactions in a blast furnace are closely related. They are summarized in Figure 6.1 on the next page. The ferrous burden is charged mainly as hematite (Fe₂O₃) with some magnetite (Fe₃O₄). The reduction of the oxides to wustite (FeO_{1.05}, we use FeO) takes place at temperatures between 600 and 900 °C. Thereafter, in the temperature range of 900 to 1100 °C, the wustite can be further reduced by gas. The chemical preparation zone can take up to 50 to 60 % of the height of the furnace and has a relatively constant temperature. This region is called the thermal reserve zone.

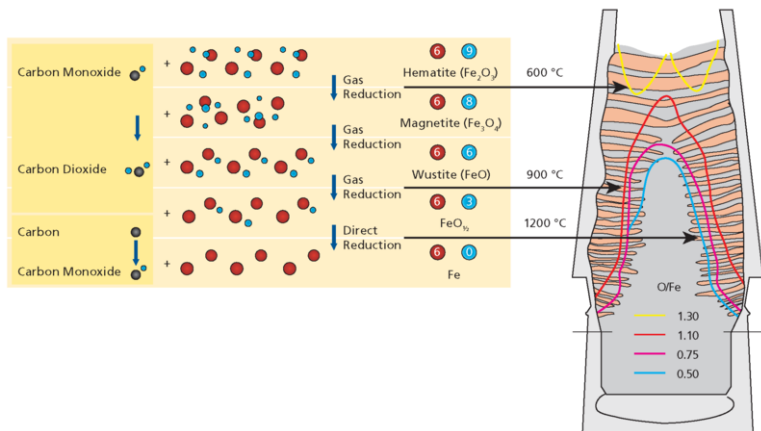
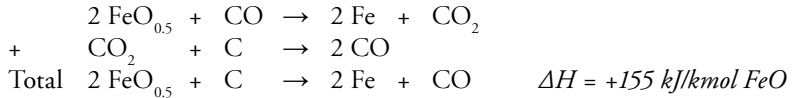

Figure 6.1 Reduction of iron oxides and the locations where the reactions have taken place in a quenched blast furnace from Omori et al, 1985

At temperatures higher than 1100 °C, carbon dioxide can react with coke carbon to produce carbon monoxide. The total reaction is known as direct reduction, because carbon is directly consumed. The reactions can be indicated as below:



- The direct reduction reaction requires an enormous amount of heat, which is provided by the heat contained in the hot raceway gas. The direct reduction reaction is very important for understanding the process. In a modern blast furnace, direct reduction removes about a third of the oxygen from the burden, leaving the remaining two thirds to be removed by the gas reduction reaction. The amount of oxygen to be removed at high temperatures, as soon as the burden starts to melt, is very much dependent on the efficiency of the reduction processes in the shaft. For an explanation of the process, it may be assumed that the gas reduction reduces the iron oxides to $\text{FeO}_{0.5}$. More efficient furnaces do exist and reach O/Fe ratio of 0.4. Note the following important observations:
- Direct reduction uses carbon (coke) and generates extra CO gas.
 - Direct reduction costs a lot of energy.
 - A significant part of the direct reduction is believed to occur in the solid phase, through reduction of CO_2 with C before the burden starts to soften. Note that, where direct reduction occurs, it does not affect the heat balance.

In operational practice the direct reduction can be monitored. In many blast furnaces the direct reduction rate (the percentage of the oxygen removed from the burden by direct reduction) or the solution loss (the amount of coke used for the reaction) are calculated on-line. Experienced operators are well aware that as soon as the direct reduction rate increases, the blast furnace burden starts to descend faster, the cohesive zone comes down as the coke is consumed faster, and the furnace chills. When properly monitored, chilling can be prevented, for example by using additional coal injection.

6.5 Carbon balance: estimation of direct reduction

Considering the carbon balance in more detail shows that not all the coke and coal is gasified at the tuyeres. Some carbon leaves the furnace with the hot metal, around 45 kg. But even then, there is a large difference: the process consumes an additional amount of carbon of approximately 100 kg/tHM. This is the carbon used for direct reduction, mostly of iron oxide. The direct reduction reaction 6.1 is:



The direct reduction reaction of iron oxides costs heat and consumes coke.

About 80–90 % of the heat in the bosh gas above a temperature of 1400 °C is needed for the direct reduction reactions. So, an increase in direct reduction will start a cooling trend in the furnace as is shown by a decrease of hot metal temperature and silicon. The cooling trend has a self-accelerating effect because: the increase in direct reduction costs heat – this consumes coke – this increases the production rate – causing an even larger heat shortage – resulting in a further increase in direct reduction. For this reason, the furnace can cool down from normal operation condition to very cold in 2–8 hours.

The variability of direct reduction is often the most important factor affecting process stability. The trend in direct reduction can be monitored in real time in the control room. It gives the operator an early warning signal for a cooling trend in the production process, because the direct reduction reaction consumes extra coke. In the event of a cooling trend, the operator has the burden descent rate as a check. Increased direct reduction and increased burden descent rate are a far faster indication than hot metal temperature or hot metal silicon measured in the casthouse. A cooling trend of this kind can be stopped by additional reductant injection. Some companies have an automatic thermal control based on the heat balance of the lower furnace.

The direct reduction can be estimated on-line from the difference between the carbon that leaves the top of the furnace and the carbon that is gasified at the raceway, as in Example 6.3.

The operator has to react to severe cooling in good time. There are basically two control methods:

- React with extra fuel (PCI) to a decrease of the thermal condition as indicated by hot metal temperature and silicon.
- React with extra fuel (PCI) to a simultaneous increase of direct reduction and burden descent speed. For direct reduction there are several calculation methods available. For descent speed several indicators can be used: descent speed as measured from stockrods, number of charges per hour, of the time needed for 5 charges.

The first method is delayed by 4–6 hours compared to the second method, since casthouse data are collected less frequently and the hearth has to be cooled down as well.

Example 6.3 Direct reduction estimation and operational example

The direct reduction consumes coke, which can be estimated from the charged amount of coke (method 1) or from the amount of carbon in top gas estimated from the top gas chemical composition (method 2). In the example, direct reduction consumes about 96 kg carbon/tHM. This means that the iron oxides are reduced by gas to a ratio of 0.47 O–atom per Fe atom.

Estimated from charges per hour and hot blast volume	tonne burden	ton HM	ton coke	kg/tHM	C %
One charge	133.5	85	25.5		
Coke				300	86
Coal				200	80
Production	tHM/hr		500		
	charges/hr		5.9		
Carbon input					
C from coke	t/hr		129		
C from coal	t/hr		80		
Total input	t/hr		209		
Carbon output					
in hot metal	t/hr		22.5		
in top gas	t/hr		186.5		
gasified in raceway	t/hr		138.1		
Carbon used for DR	t/hr		48.4		
for DR of Si, Mn	t/hr		2.9		
for DR of iron oxides	t/hr		45.5		
	kg/tHM		91.1		
O/Fe burden for DR			0.45		
% DR (oxygen removed from iron oxides)			30.8		

Estimated from top gas composition		N ₂	H ₂	CO	CO ₂	m ³ STP	kg C/tHM
Bosh gas	m ³ STP/tHM	659	114	516		1289	276.2
	%	51.1	8.9	40			
Top gas	%	46.3	5.1	26.1	22.6		
	m ³ STP/tHM	659	72	372	321	1425	371.2
Carbon used for DR	kg C/tHM						95.1
Hydrogen utilization			37 %				

Table 6.3 Calculation of amount of carbon used for direct reduction

In addition to the direct reduction of iron (typically from FeO_{0.5}) some other materials are also directly reduced in the high temperature area of the furnace.

The amount of carbon used for these direct reduction reactions is indicated in Table 6.4. This can be calculated from the chemical composition and the atomic weights, considering that the amount of oxygen removed reacts with the carbon in the coke. Assuming that the iron oxides are directly reduced from an O/Fe = 0.47 the carbon used for direct reduction is 101 kg C/tHM corresponding to 117 kg coke/tHM.

Material	reduced to	hot metal	kg C/tHM
FeO _{0.5}	Fe	94.50 %	101.5
SiO ₂	Si	0.40 %	3.4
MnO	Mn	0.30 %	0.7
TiO ₂	Ti	0.05 %	0.3
P ₂ O ₅	P	0.07 %	0.7
S in hot metal	S in slag *	0.90 %	0.8
Total accompanying elements			5.8

Table 6.4 Typical coke consumption for direct reduction, including oxides
 * – Desulphurization reaction $(CaO) + [C] + [S] \rightarrow (CaS) + CO$

In operating furnaces the variability of direct reduction is the major cause of variation of the thermal level. Since direct reduction consumes coke as soon as it increases, the burden descent starts to increase. Simultaneous increases of the burden descent and the direct reduction as calculated from the gas composition are a strong indication that preventive measures have to be taken, such as increasing PCI. Figure 6.2 shows an example, where direct reduction (white) and burden descent (see charges per hour in yellow) increase, while hot metal silicon (green) decreases from 0.43 to 0.2 %. This phenomenon can be observed in every furnace every few days, because variability of direct reduction is due to variability of heat losses and/or raw material quality.

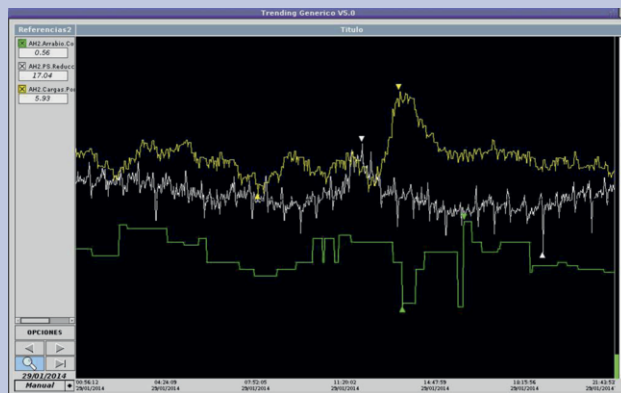

Figure 6.2 Example of increased direct reduction and related effects

6.6 Gas and burden composition during processing

In the preceding section the temperature profile in the blast furnace has been detailed. In this section the gas in the furnace will be dealt with in more detail. Wind is blown through the tuyeres, along with coal or natural gas and moisture, generating gas at high temperature. The gas temperature is called Raceway Adiabatic Flame temperature (RAFT, T_{flame}).

6.6.1 Raceway adiabatic flame temperature

The flame temperature in the raceway is the temperature that the raceway gas reaches as soon as all carbon, oxygen and water have been converted to CO and H₂. The flame temperature is a theoretical concept, since not all reactions are completed in the raceway. From a theoretical point of view, it should be calculated from a heat balance calculation over the raceway. For practical purposes linear formulae have been derived (see Example 6.4). But every company has its own formula, which differs in the details considered and the starting situation for which the formulae have originally been derived.

Flame temperature is normally in the range of 1900 to 2300 °C and is influenced by the raceway conditions. The flame temperature increases if:

- Hot blast temperature increases.
- Oxygen percentage in the blast increases.

The flame temperature decreases, if:

- Moisture increases in the blast.
- Reductant volatiles increase, due to energy required for cracking the chemical bonds.
- Reductant injection rate increases, since cold reductants are gasified instead of hot coke. The precise effect depends on auxiliary reductant composition as well. Table 6.5 provides some basic rules with respect to flame temperature effects.

			T_{flame}	T_{top}	η_{CO}
Blast temperature	°C	+100	52.8	-15.2	0.6
Coal	kg/tHM	+10	-26.6	9.4	-0.1
Natural gas	kg/tHM	+10	-75.8	20.1	-0.1
Fuel oil	kg/tHM	+10	-45.7	13.5	-0.1
Oxygen	%	+1	33.9	-14.0	0.0
Moisture	g/m ³ STP	+10	-42.5	8.6	-0.4

Table 6.5 Flame temperature effects, rules-of-thumb (calculated with mass and heat balance for the reference furnace).

Example 6.4 Estimation of Flame Temperature (T_{flame})

Flame temperature (T_{flame}) can be estimated from linearized formulae. The formula below is in close agreement with more rigorous heat and mass balance model calculated values. A notable improvement over the original simple formulae is that it takes coal chemistry and cracking heat into account. With the variety in coal chemistry and VM now in use, it is important that the coal type is taken into account. For example, a high VM coal at a high injection rate can have a real flame temperature 200 °C lower than a low volatile coal. Note that for injectant, it is the concentration of injectant in the blast (kg/m^3), rather than kg/tHM , that affects flame temperature. Higher oxygen enrichment and lower fuel rate operation both give a lower blast volume/tHM leading to a greater impact on flame temperature of a given injectant rate.

$$T_{\text{flame}} = \frac{(BT + 1961 - \alpha \cdot \text{Coal}/\text{WC} + 112.5 \cdot \text{OE} - 1.992 \cdot \text{BM} - 5203.9 \cdot \text{Gas}/\text{WC})}{(1.287 + 0.02133 \cdot \text{OE} + \beta \cdot \text{Coal}/\text{WC} + 0.00257 \cdot \text{BM} + 2.77687 \cdot \text{Gas}/\text{WC})} \quad (6.1)$$

$$\alpha = 1.162 \cdot 2.9439 \cdot (5.467 \cdot C \cdot (1 - \text{moist}/100) + Q_{\text{crack}}/4.1868 + 11.945 \cdot \text{moist})$$

$$\beta = 2.9439 \cdot (0.03726 \cdot H \cdot (1 - \text{moist}/100) + 0.0086475 \cdot \text{moist}) + 0.006938 \cdot \text{Ash} \cdot (1 - \text{moist}/100)$$

$$C = \text{C in coal (dry \%)}$$

$$H = \text{H in coal (dry \%)}$$

$$\text{moist} = \text{coal moisture, as injected (\%)}$$

$$\text{Ash} = \text{Ash in coal (dry \%)}$$

$$BT = \text{hot blast temperature (}^\circ\text{C)}$$

$$\text{Coal} = \text{coal rate (kg/tHM)}$$

$$\text{Gas} = \text{Natural gas rate (kg/tHM)}$$

$$\text{WC} = \text{specific blast volume, including oxygen enrichment (m}^3 \text{ STP/tHM)}$$

$$\text{OE} = \text{oxygen enrichment (O}_2 \text{ \% - 20.9)}$$

$$\text{BM} = \text{blast moisture (g/m}^3 \text{ STP)}$$

$$\text{VM} = \text{coal volatile matter (dry \%)}$$

$$Q_{\text{crack}} = \text{cracking heat of coal (MJ/kg) - can be measured or estimated from Equation 5.2:}$$

$$Q_{\text{crack}} = 0.0007 \cdot \text{VM}^2 + 0.0126 \cdot \text{VM} - 0.3687 \quad (\text{If } Q_{\text{crack}} < 0 \text{ then } Q_{\text{crack}} = 0)$$

There is a connection between T_{flame} and top gas temperature: the higher T_{flame} , the less gas is required for the heat required in the lower furnace (lower furnace is the area with a temperature above 900 °C). As a consequence, there is less gas in the upper furnace, and so top gas temperature decreases. However, there are considerable response times for the increase and decrease of top temperature after the change of blast conditions, up to 10 hours or more. Note that the oxygen percentage in the hot blast determines the bosh gas volume and so has an effect on the changes in T_{flame} . An example as estimated for the reference furnace is given in Figure 6.3 on the next page.

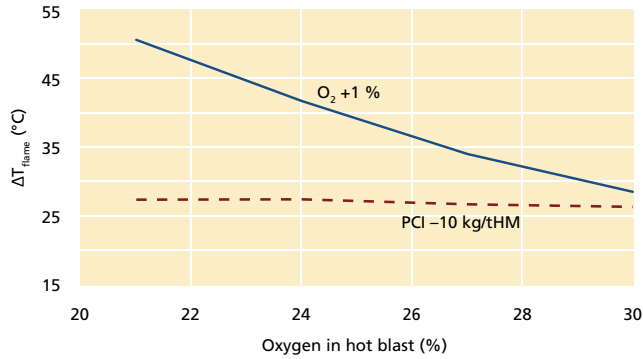

Figure 6.3 Effects on T_{flame} vary with blast conditions and depend especially on blast oxygen content. Effect of changes in T_{flame} are shown for 1 % additional O₂ enrichment and for a decrease of PCI rate by 10 kg/tHM.

6.6.2 Gas composition and ferrous burden processing

The gas in the blast furnace is processed in five steps. In the real blast furnace these steps are overlapping.

- Step 1: Wind is blown through the tuyeres along with coal or natural gas and moisture. All these components react to form carbon monoxide (CO), hydrogen and nitrogen. So, the conditions at the end of the raceway are a high temperature of 2000 to 2200 °C and CO, H₂ and N₂ in gaseous form.
- Step 2: The gas ascends in the furnace and cools down to 1200 °C. The direct reduction reactions take place, generating additional CO gas. On reaching 1200 °C, the gas leaves the cohesive zone and enters the furnace stack filled with granular materials. At temperatures over 1000 °C gas reduction is very limited, as any CO₂ formed reacts instantaneously with coke to CO, a reaction which is thermodynamically equivalent to direct reduction.
- Step 3: The gas continues to ascend, its temperature decreases from 1200 to 900 °C. In this temperature range, the hydrogen is very effective and about 35 % of the hydrogen picks up oxygen from the ore burden (against about 24 % of the CO). At 900 °C the burden O/Fe ratio is 1, η_{CO} is around 24 % and η_{H_2} around 35 %.
- Step 4: The gas continues to ascend cooling to 600 °C. At this temperature, the ore burden has the composition of magnetite, Fe₃O₄.
- Step 5: The gas cools down further to the temperature at which it will leave the furnace at the top (110 to 150 °C). In this area, the carbon monoxide is utilized further and removes more oxygen from the ore burden, although at temperatures below 500 °C, the reduction no longer proceeds.

In terms of gas volume, once the temperature of the gas has dropped below 1000 °C, the total gas volume in m³ STP per tonne of hot metal is constant, only the composition of the gas changes, as shown in Figure 6.4. In this book the basis of mass and heat balances are treated; an excellent overview has recently been published (Cameron et al, 2020).

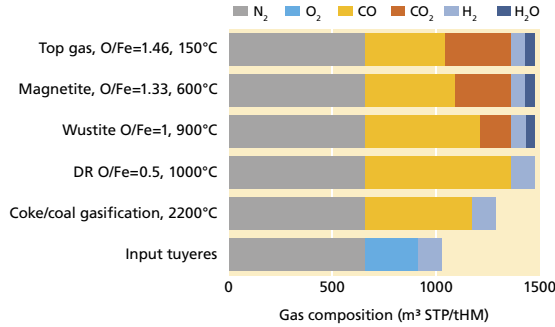

Figure 6.4 How top gas is formed from hot blast

It is clear from Figure 6.4, that the major part of the gas through the furnace consists of nitrogen. Nitrogen is chemically inert and delivers only its heat from the hot blast to the burden. During its five to eight seconds journey through the furnace it cools down from the blast temperature to the top gas temperature. For comparison in Figure 6.5, processing the burden is shown by demonstrating the weight and composition of gas and burden in kg/tHM. The weight at the top of approximately 1600 kg ferrous burden including gangue and 300 kg coke decreases gradually to 1000 kg of hot metal and 250 kg of slag. The balance is eliminated from the furnace with the top gas. How hot metal and slag are formed is discussed in the next chapter.

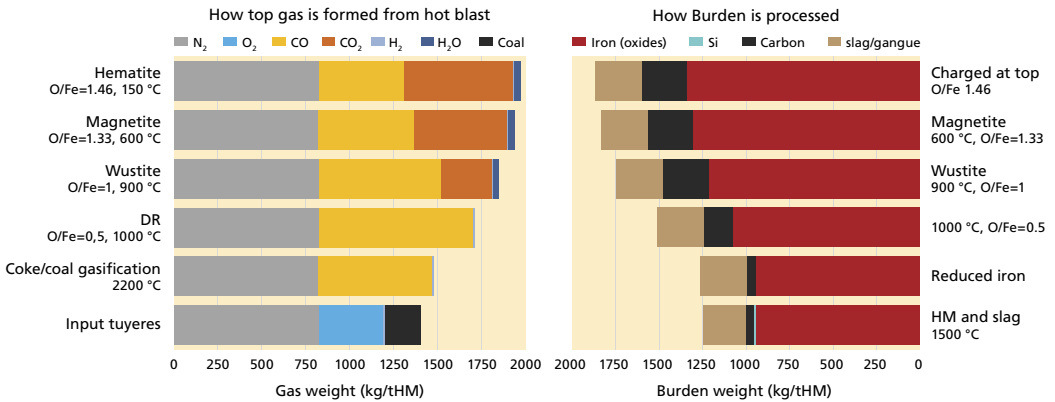

Figure 6.5 Blast furnace process showing counter-current gas and material flow and the weights at varying temperatures in kg/tHM

6.6.3 The heat or energy balance

The energy or enthalpy input into the blast furnace consists of the energy represented in the coke and coal and the sensible energy in the hot blast. Coke and coal have an energy content of about 30 GJ/tHM. Per tonne, approximately 500 kg is used. Some 45 kg carbon is eliminated with hot metal, which contains 4.5 % carbon.

Typical energy input into the blast furnace:

- 500 kg coke and coal, 15 GJ/tHM.
- Hot blast, typically 1.5 MJ/tHM.
- In total, some 16.5 MJ/tHM.

Typical outputs are:

- Chemical and thermal energy top gas: 5.5 MJ/tHM, of which around 35 % is being reused for fueling the hot blast stoves. The balance is mostly used for power generation.
- Chemical energy hot metal: Fe 7 GJ/tHM, C 1.5 GJ/tHM and Si 0.2 GJ/tHM
- Sensible heat around 2 GJ/tHM: hot metal (64 %), slag (14 %), top gas (12 %) and heat losses (10 %).
- In total it is 16.2 GJ/tHM. The small differences are for instance due to use of rounded numbers, neglect of chemical reactions of e.g. Mn and tuyere heat loss.

Basically, producing hot metal costs 16 GJ/t, of which 5 GJ/tHM is lost/expelled with top gas. The heat balance as derived for the standard furnace is presented in Figure 6.6. To put this into context, the net energy requirement for the reference furnace equates to the output of one of the two units of the most recent nuclear plant commissioned in China (Taishan), at 1.75 GW.

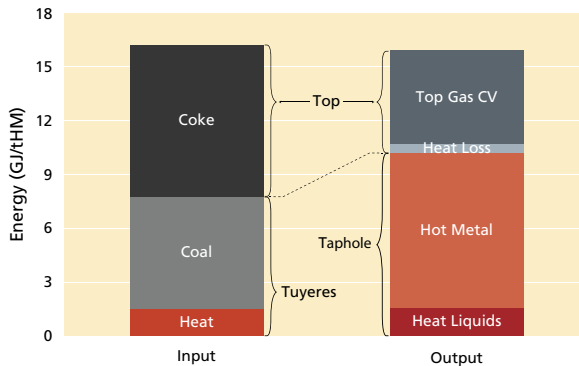

Figure 6.6 Energy input and output in a blast furnace; heat is the sensible heat of the hot blast (left) and cooling water, top gas, hot metal and slag (right).

Another method to describe the counter-current mass and heat exchange in the blast furnace is with a graphical tool in the Rist-diagram. This is more advanced and shown in Annex VII.

6.6.4 Where are coke and coal consumed?

In the typical blast furnace, the oxygen blown into the furnace via the tuyeres is converted to CO in the raceway. The oxygen input per tonne of HM coming from the hot blast is typically 240–260 Nm³ O₂/tHM. The blast oxygen is used to gasify the coal and some additional coke (see Example 5.1 for gasification of

coal).

The direct reduction consumes coke. It takes place in and probably above the area of the cohesive zone at burden temperatures between 1000 and 1400 °C. The carbon dissolution takes place at slightly higher temperature as soon as the hot metal is liquid. The results are presented graphically in Figure 6.7.

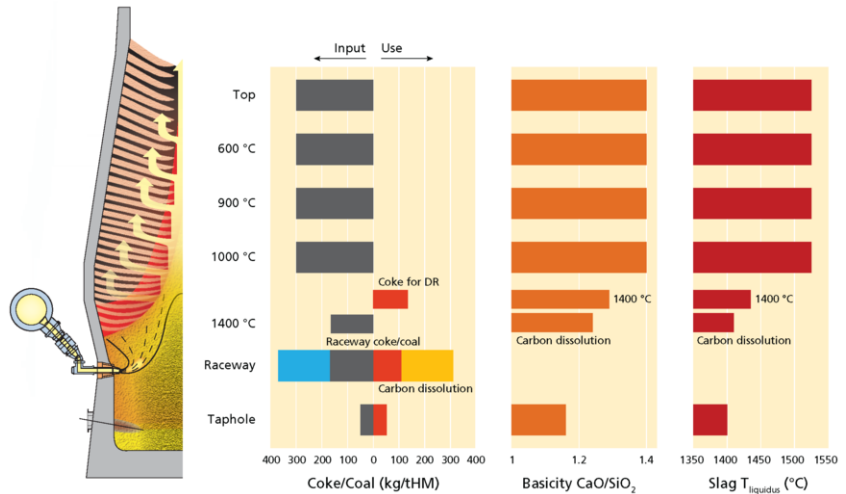

Figure 6.7 Coke and coal use in a blast furnace (left), local basicity and liquidus temperatures

As a result of coke being consumed, the coke ash is blended into the slag. Since coke and coal ash consist mainly of acid components (SiO_2 and Al_2O_3), the basicity of the slag decreases and the slag liquidus temperature is reduced as well. The example above is derived from the reference blast furnace used throughout this book.

It has to be mentioned, that slag formation at the tuyeres is a special case. For every tonne of hot metal, 200 kg coal and 135 kg coke are gasified in the raceway generating some 32 kg slag per tonne of hot metal. Some slag components are gasified, especially SiO_2 , of which around 10 kg is reduced to atomic silicon dissolving in the hot metal. This makes the slag components in front of the raceway a slag high in Al_2O_3 with liquidus temperatures well above 1800 °C.

Another important aspect is, that injection coals with a high ash percentage force the operator to make the “primary slag” in the cohesive zone more basic in order to reach the same final slag basicity. This can jeopardize melting of the ferrous burden.

6.7 Permeability

There is a large difference between the permeability of coke and burden. Coke is larger than ferrous materials and has more voidage. Ferrous burden average size is much smaller and contains more fines (material smaller than 5 mm); hence its gas permeability is poorer. Figure 6.8 shows the pressure drop required for a standard flow in mm water gauge per meter bed height. From the data of the figure: resistance to gas flow is 4–5 times as high for a sinter burden as for coke.

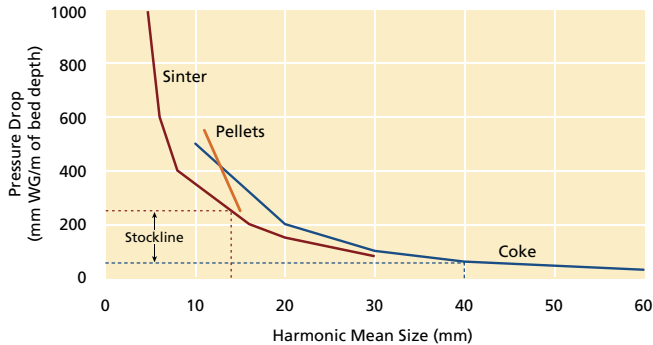

Figure 6.8 Permeability difference: coke (HMS 40 mm) and sinter (HMS 14 mm)

In a typical furnace with a sinter burden, over 80 % of the resistance to gas flow comes from the ferrous burden. The surface mean (harmonic mean) diameter for coke is about 40 mm whereas for sinter it is typically 14 mm. The pressure drop chart shows that coke is permeable for gas, and ferrous burden has a relatively high resistance for gas flow. Gas flowing through a blast furnace takes the path of least resistance, making the burden distribution the major tool for gas flow control as discussed in the next chapter.

6.7.1 Permeability: the K-factor

The hot blast is pressurized by a blower and is transported through the furnace, because the pressure at the top is lower than the pressure in the hot blast main. Blast furnace operators are interested in the permeability of the material column inside the furnace, because the more blast can be transported through the furnace, the higher the production, since more coke is gasified. The furnace can be driven to higher production to a maximum ΔP (blast pressure minus top pressure), but when exceeding the ΔP above this maximum, the burden descent deteriorates, the furnace becomes less efficient and productivity will decrease. How are blast pressure and blast volume related? In its simplified form the equation of Bernouilli states that

$$P = \frac{1}{2} \cdot \rho \cdot v^2 \quad (6.7.1)$$

Where P is the (dynamic) pressure, ρ the density (kg/m^3), v the velocity (m/s).

Or in other words, to transport twice the amount of gas through a blast furnace, doubling v , pressure has to increase by a factor of four.

Blast furnace operators are interested in the permeability. This is characterized by monitoring how much pressure is required to transport the gas through the furnace, as indicated by the permeability factor K :

$$K = [(BP + 1.033)^2 - (TP + 1.033)^2] / (BGV)^{1.7} \quad (6.7.2)$$

Where BP is blast pressure and TP is top pressure in g/cm^2 , BGV is bosh gas volume in m^3 STP/min. The factor 1.033 has to do with adjustment from atmospheric to absolute pressure ($g/cm^2 = bar \cdot 1019.72$). Note that the K -factor is called the permeability factor, but the higher the K -factor the poorer the permeability.

Some companies use partial- K -factors for upper and lower part of the furnace. This provides good information over the permeability of the cohesive zone (lower part) and upper part of the furnace. The total K -factor remains the sum of the partial- K factors. Different companies use different characterizations, for instance a resistance index or use ΔP /blast volume.

K -factors are thought to reflect the properties of the burden. However, there are many more influences that have impact on the ΔP and hence on K -factors.

1. Variability: the pressures in a blast furnace are rather variable with typical minute-to-minute variations of $\pm 5\%$. Since in the short term the material column is constant, this is caused by the constantly changing permeability in the cohesive zone, as iron and slag drip through it.
2. Channeling. Channeling is the process whereby the gas follows a preferential path along the wall in the furnace. The hot gas will also lead to high heat loads on the cooling system and to short-circuiting in the pressure taps; that means the same pressure at different heights.
3. Top gas temperature and water vapor are not taken into account in the K -factor, while top gas temperature has an impact (section 6.7.2).

6.7.2 The pressure differences over the furnace height

The pressure difference between hot blast and top pressure depends on the blast volume and the furnace itself. The 'allowable' maximum ΔP depends on the furnace and the burden, and is a specific value for each furnace. Large 14 meter hearth diameter furnaces can work up to a maximum ΔP of 2 bar or even higher. Note that this is an instantaneous maximum. Some furnaces have systems which automatically lower the blast volume when reaching the maximum ΔP in order to prevent hanging, slips and process upsets. Smaller furnaces have maximum ΔP of 1.5–1.8 bar.

- The pressure difference can be subdivided into three parts:
- over the tuyeres
 - over the lower part of the furnace (some 8 meters above the tuyeres)
 - over the upper part

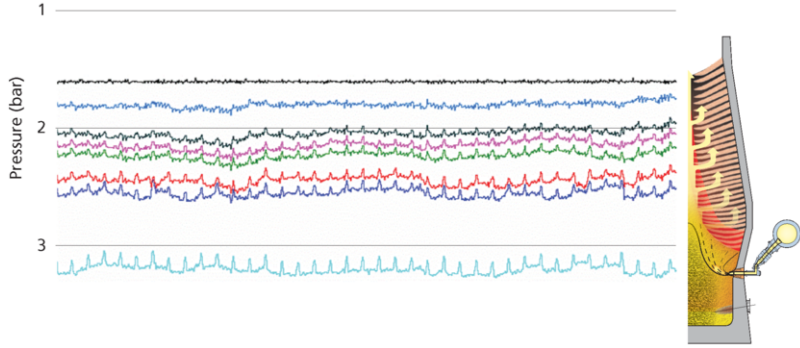

Figure 6.9 Typical pressure difference over a blast furnace

The pressure difference over the tuyeres (ΔP_{tuy}) is typically 0.35–0.65 bar, depending on wind velocity in the raceway. The wind velocity in the tuyeres can be estimated from Formula 6.7.3.

$$V_{\text{tuy}} = ((T_{\text{blast}} + 273.15) / 273.15) \cdot ((1.01325 / (P_{\text{blast}} + 1.01325)) \cdot V_{\text{blast}} / (A_{\text{tuy}} \cdot 60)) \quad (6.7.3)$$

- where V_{tuy} is the tuyere velocity in m/s
- T_{blast} the hot blast temperature, °C
 - P_{blast} the blast pressure, bar
 - V_{blast} the blast volume, m³ STP/min
 - A_{tuy} the total tuyere surface diameter, m²

The pressure difference over the tuyeres is dependent on wind velocity. A higher wind velocity yields a higher ΔP_{tuy} as shown in Figure 6.10. The ΔP_{tuy} (in bar) can be estimated from a linearized formula 6.7.4 below.

$$\Delta P_{\text{tuy}} = V_{\text{tuy}} \cdot 0.0035 - 0.353 \quad (6.7.4)$$

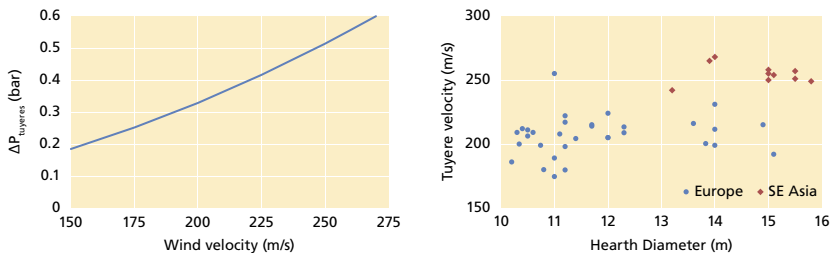

Figure 6.10 Wind velocity and pressure difference over the tuyeres (left) and benchmark of tuyere velocity in selected operating furnaces (right)

Internationally, there are different tuyere velocities being used by South–East Asian operators and European and North American operators (Figure 6.10). South East Asian operators prefer to work at tuyere velocities of 240–260 m/s while in Europe and North America, 200–220 m/s is the preferred range. The former prefer a large penetration of the hot blast in order to minimize the size of the deadman. To this end, long tuyeres (longer than 60 cm) are frequently used as well. The latter take into account a lower minimum tuyere velocity, because wind distribution over the tuyeres is sufficiently symmetric. Moreover, they prefer to control the gas flow with burden distribution and use shorter tuyeres (40–50 cm). This makes the tuyeres less vulnerable.

Some companies place a greater importance on the kinetic energy, also called blast momentum, per tuyere (kg.m/s), rather than the tuyere velocity. Raceway probing with an accelerometer has demonstrated that this is the more important parameter to maintain the raceway stability. If the kinetic energy is too low then the raceway becomes unstable and the active raceway shrinks periodically. This will increase the heat load on the tuyeres, and cause more wall gas flow.

$$KE_{\text{blast}} = 0.5 \cdot (B_{\text{flow}}/N_{\text{tuy}}) \cdot V_{\text{tuy}} \cdot V_{\text{tuy}}/9.81 \quad (6.75)$$

where KE_{blast} is the blast kinetic energy (momentum) in kg.m/s

B_{flow} is the blast flow in kg/s

N_{tuy} the number of tuyeres

V_{tuy} as in 6.74

Biswas quotes a range of 3000–9000 kg.m/s. European plants tend to operate between 3000 and 9000 kg.m/s depending on hearth diameter. On large Asian furnaces values up to 12500 kg.m/s are more typical.

The pressure difference over the upper part of the furnace is determined by the size distribution of the burden and coke rate. But this is difficult to use as a tool for the quality of the burden, since the pressure difference varies not only with gas flows through channels, but also with the top temperature and moisture content of the top gas. This is because at higher temperature gas expands and more real m³ of gas have to be transported through the upper furnace.

An example of the relation between ΔP of the upper furnace and the top temperature is shown in Example 6.5 on the next page. High moisture to be eliminated from the furnace has a similar effect on ΔP of the upper furnace. Some operators have reported an increase in pressure difference over the upper zone when they have charged excessive fines; this has led a few hours later to problems in the lower zone.

Example 6.5 Pressure drop and top temperature

The pressure needed to drive gas through a blast furnace increases with increasing top gas temperature. Why? At higher temperature gas expands, so more real m^3 of gas have to be transported, especially through the upper furnace. As a consequence of the increase in ΔP the K-value deteriorates. This can be observed in operational practice, and an example is shown below in Figure 6.11. In this case the relatively high top temperature was caused by asymmetric process as a consequence of worn throat armor.

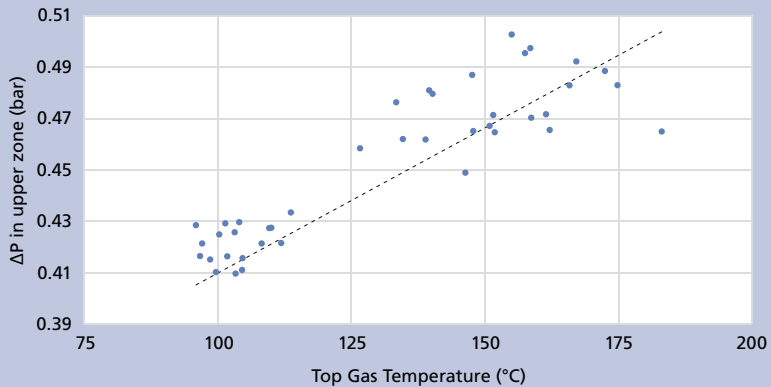

Figure 6.11 A typical example of the relation between top gas temperature and ΔP upper furnace (14 m furnace, inner volume 4050 m^3)

6.7.3 PCI and permeability

In current operation scenarios, a relatively large part of the reductant requirement of a blast furnace comes from auxiliary injectants like pulverized coal (PCI) and/or natural gas. When increasing the injection level, what happens with the permeability of the blast furnace? When increasing reductant injection, part of the coke is replaced by burden, hence the permeability of the blast furnace becomes poorer. This is illustrated in Figure 6.12.

What happens if the PCI rate is increased from 60 kg/tHM to 200 kg/tHM? At 60 kg PCI/tHM the coke layer and ferrous layer are the same thickness. If the PCI is increased by 140 kg/tHM to 200 kg/tHM, some 120 kg/tHM coke has to be taken out of the charge. So, the coke layer decreases and the resistance will increase (Figure 6.12).

Operational practice is somewhat more complicated.

1. When increasing PCI, ΔP increases and this is compensated by increasing the oxygen enrichment of the hot blast. Since the furnace then operates with less N_2 per tonne, the gas volume per tonne decreases and the same production can be made with less gas, so with a lower ΔP .

2. If PCI is increased without increasing oxygen enrichment, then top temperature will increase. And this will lead to a higher ΔP over the upper furnace. An operational example is elaborated in Example 6.6.
3. However, if the furnace is operated at higher PCI, the weight of the material column above the cohesive zone increases, and hence the maximum acceptable ΔP increases as well. This is illustrated with an operational example in Figure 6.12, where ΔP_{max} is the momentary value of ΔP , which increases at decreasing coke rate and the weight of the burden column above the cohesive zone is estimated. When ΔP_{max} is exceeded, the blast volume is reduced.

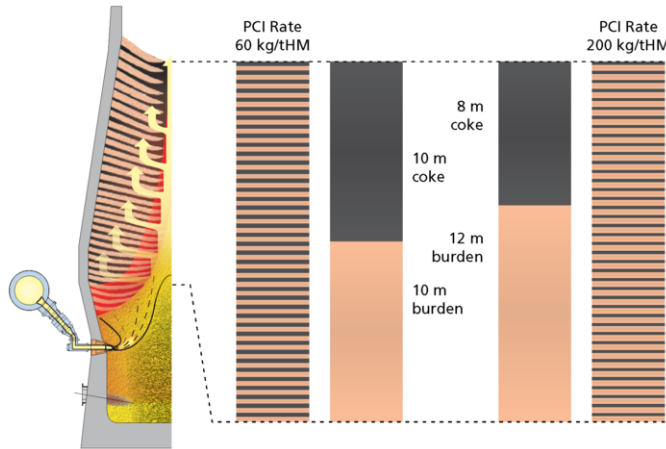

Figure 6.12 Effect of Increasing PCI on burden layers

When coke rate decreases, the weight of the burden increases. As will be explained in Chapter VII, the higher weight will allow for a higher maximum value of ΔP , because the weight of the burden and coke above the cohesive zone increases. It can be estimated and Figure 6.13 shows the weight (in kgf) and the maximum allowable ΔP as a momentary value for an operating furnace.

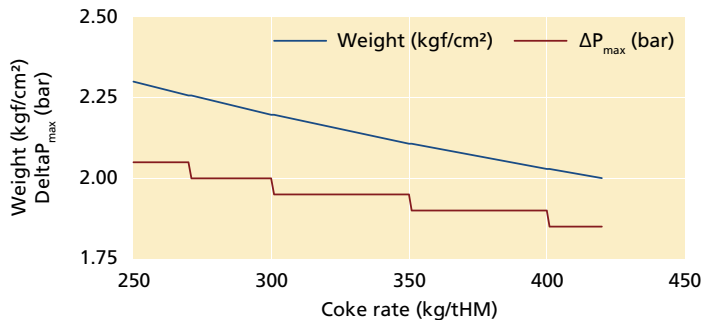

Figure 6.13 Increasing burden weight (calculated) allows a higher maximum allowable ΔP for a blast furnace. The dotted line is from operating instructions of a 4500 m³ inner volume blast furnace.

Example 6.6 PCI rate, coke rate and permeability.

Increasing PCI rate at constant oxygen enrichment will lead to a higher top temperature (Table 6.5). Hence, increasing PCI with its consequent reduction of coke rate (at constant blast volume and oxygen enrichment) will result in:

- An increase of ΔP because permeable coke is replaced by less permeable ferrous burden.
- An increase of ΔP because top temperature increased.

An example of blast furnace operation is shown in Figure 6.11 from the early days of coal injection in Europe. At the time, the plant was short on oxygen capacity and thus operators tried to reach as high PCI rates as possible without additional oxygen enrichment. It is clear from the figure that the increase in ΔP is caused by the increased upper ΔP .

More than 60 % of the ΔP increase was due to the increased top temperature and less than 40 % to the replacement of coke by ferrous burden. The dotted line in Figure. 6.14 is the calculated pressure difference taking only replacement of coke by ferrous burden into account. The difference between the calculated (red-dotted) line and the measured (solid) line is due to increased top temperature.

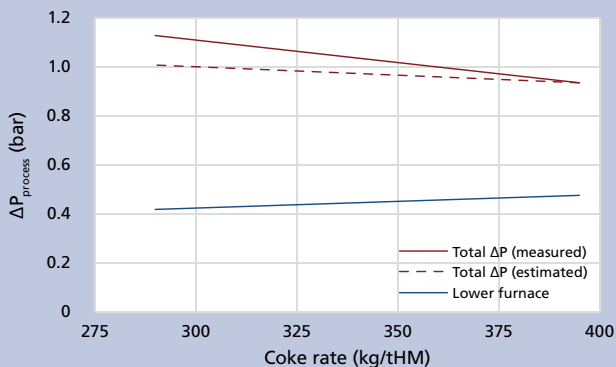

Figure 6.14 $\Delta P_{\text{process}}$ as measured inside a blast furnace at decreasing coke rate. The dotted line is calculated taking only the higher burden fraction at lower coke rate into account

6.8 Blast furnace efficiency

The efficiency of the furnace is the amount of reductant used per tonne of hot metal. It is the sum of coke, nut coke and auxiliary injectants. The total reductant rate (in kg/tHM) can be standardized calculated as

$$\text{Reductant rate} = \text{coke rate} + \text{nut coke rate} + \text{RR} \cdot \text{coal rate} + \text{RR} \cdot \text{gas rate} \quad (6.8.1)$$

Some companies use a standardized coke, for instance with 87.5 % C, to make a consistent total reductant rate over the years. Actual coke and nut coke chemistry are recalculated to the standard coke and replacement ratios (RR) are determined with respect to the standard coke. Some companies use as the total reductant the Formula 6.8.2:

$$\text{Reductant rate} = \text{coke rate} + \text{nut coke rate} + \text{coal rate} + \text{gas rate} \quad (6.8.2)$$

If management focuses too much on the results of 6.8.2, then optimization by higher coal injection is frustrated, since injection coals have a replacement ratio of typically 0.9, so the reductant rate increases at higher injection rates. In fact, higher PCI is attractive:

- costs are lower since PCI coals are much cheaper than coking coals, especially if the PCI equipment has spare capacity.
- environmentally more friendly, since the coking process is partially avoided.

The total amount of reductant per tonne decreases when the heat input into the furnace is larger (for example higher hot blast temperature) or the heat requirement is smaller. The major parts of the heat requirement are

- the heat used for the direct reduction reactions,
- the heat required for bringing hot metal and slag to casting temperature and
- the heat losses through the furnace wall.

The gas composition of the top gas is often indicated as “Top Gas Efficiency”, “Top gas Utilization” or η_{CO} (as % in dry top gas):

$$\eta_{\text{CO}} = \frac{\text{CO}_2}{\text{CO} + \text{CO}_2} \times 100 \% \quad (6.8.3)$$

η_{CO} is typically in the range of 45–50 %. Increase of η_{CO} means, that the oxygen from the burden is removed with less gas thus with less coke and the furnace becomes more efficient. A similar factor is the hydrogen utilization,

$$\eta_{\text{H}_2} = \frac{\text{H}_2\text{O}}{\text{H}_2\text{O} + \text{H}_2} \times 100 \% \quad (6.8.4)$$

The η_{H_2} can be estimated from the input of H_2 through the tuyeres and the output with the top gas, the balance being the H_2 utilized in the process. η_{H_2} is especially important for furnaces using natural gas.

The main factors determining the efficiency are:

- The better the contact is between gas and ferrous burden, the better the gas reduction and the lower the direct reduction reactions and the reductant rate. Another aspect is the amount of fines smaller than 5 mm that are charged or generated in the furnace. This is important because more fines block the gas flow and decrease the permeability of an ore layer, especially when the fines are concentrated in certain radial areas, as for example at the wall. This is discussed in Chapter VIII.
- How easily is oxygen removed from the ferrous burden? This is largely determined by the size distribution and softening/melting properties of burden materials. Lump ore is less accessible to gas than sinter or pellets, so lump ore has a penalty, which varies from type to type but is typically an additional 50 kg coke for a tonne of hot metal made from lump ore.
- How much slag has to be processed per tHM.

It is often difficult to grasp the actual picture of the efficiency of the furnace in its control room, since different parameters are used for different reductants, for example tonne of coal or m³ of natural gas per hour and coke rate per tonne of hot metal. Operators have to know how to “translate” these parameters to reductant rate (kg/tHM). Rules of thumb are in Annex III.

On-line monitoring of the efficiency is possible by close attention to the chemical composition of the top gas. However, this is not easy either, since there are many effects on the gas composition.

The complications with the interpretation of the gas utilization come from:

- Interference with driving rate of the furnace: the faster the burden descends, the more oxygen is removed from the burden. If the driving rate increases, then the top temperature will go down.
- Interference with burden level: if burden level is low due to charging problems, gas utilization will decrease, since the first reduction step from hematite to magnetite does not take place in the top of the stack. When filling the furnace, the gas utilization improves above the earlier level.
- Competition between hydrogen and carbon monoxide. Part of the oxygen of the burden is removed with hydrogen. So, as soon as an operator changes the setting for moisture, the CO gas utilization changes. The same applies for changes in set points of injectants.

Another aspect that follows from the gas analysis is the amount of coke that is used in direct reduction reactions. This becomes manifest from the percentage of CO + CO₂ in the top gas. However, this percentage also varies with the moisture and oxygen percentage in the hot blast, so it is recommended to have an on-line calculation available that expresses the direct reduction in carbon rate or coke rate per tonne of hot metal as shown in Section 6.5.

6.9 Productivity

The productivity of a blast furnace is the amount of hot metal produced per unit time. It is often expressed as tonnes of hot metal produced per 24 hours (without delays) either per m^3 working volume or per m^3 inner volume or per m^2 hearth surface. High productivity for large furnaces is 2.4 tonnes of hot metal per m^3 inner volume per 24 hours. Smaller furnaces tend to have higher productivity, because there is a smaller deadman beyond the raceway.

The limiting factors for the production rate can be

- the process: how much wind the furnace accepts?
- the casthouse: how much liquid can be drained?

What determines the productivity of a blast furnace? It is a simple question with a complicated answer. The areas to consider are:

- Burden quality and slag volume;
- Furnace efficiency and the minimum coke rate that can be attained;
- Process conditions (hot blast pressure, temperature, moisture, O_2 enrichment).
- Equipment: charging capacity, capacity of turbo blowers, availability of oxygen.

6.9.1 Burden quality and slag volume

The blast furnace burden consists of sinter, pellets and lump ore. Lump ore is very variable in quality and is in general not helpful for high productivity. Properties of burden materials for high productivity have been discussed in Chapter III.

An important factor is the slag volume per tonne of hot metal. It has been observed that over a wide range of slag volumes, productivity deteriorates with increasing slag volume. This was found for similar size furnaces at different plants, as well as for different size furnaces at one site. Typically, productivity decreases by $0.05 \text{ t/m}^3 \text{ IV.24hrs}$ for an increase in slag rate of 10 kg/tHM . The slag effect is the consequence of improved permeability of the cohesive zone resulting from less slag and of the reduced heat requirement.

The charge of metallic iron units (scrap, DRI–Direct Reduced Iron, HBI–Hot Briquetted Iron) lowers the reductant rate and increases the furnace efficiency, since metallic iron is already reduced. Details are in Chapter III.

6.9.2 Furnace efficiency.

The productivity of a furnace increases as the reductant rate decreases, since in a more efficient furnace more hot metal is produced with the same amount of reductant. In front of the tuyeres, about 350 kg coke and coal is gasified per tonne of hot metal, since about 100 kg coke is used for direct reduction and some 50 kg for dissolving carbon in hot metal. This means that for every 3.5 kg lower reductant rate, production increases by 1% .

6.9.3 Process conditions for high productivity

The more coke that is gasified at the tuyeres, the more iron is produced. More coke is gasified by blowing more hot blast or using more oxygen at the same blast volume. The following limitations are met:

- ΔP_{\max} : a furnace cannot exceed the maximum ΔP : burden descent starts to deteriorate above ΔP_{\max} or, with constant top pressure, maximum blast pressure.
- O_2 enrichment: the more oxygen that is present in the hot blast, the more coke that is gasified and the more productivity increases. However, there is a limit to the amount of oxygen enrichment that can be used: increase of oxygen percentage in the hot blast leads to a lower top gas temperature. As soon as the top temperature falls becomes too low (below 100 °C), the furnace becomes less efficient, since it takes more time to start the reduction reactions.
- Metallurgical coke rate: the metallurgical coke layers (so the coke without the nut coke) form the grid in the cohesive zone through which gas ascends and the melting hot metal and slag descend. If the coke layers become too thin, there will be contact between sequential ferrous layers and the gas flow through the furnace becomes unstable. The minimum metallurgical coke rate also depends on the slag volume that has to percolate through the grid. A minimum metallurgical coke rate means a maximum PCI with the highest oxygen enrichment, and this drives productivity. Minimum metallurgical coke rates are reported at 230–240 kg/tHM, plus nut coke rates around 30 kg/tHM.

Maximum productivity (with a given burden and injectants) is reached when:

- Top pressure is at the maximum value.
- Blast volume is set so that the furnace is operated to the maximum ΔP .
- Hot blast temperature is set at the highest achievable value, since it lowers the fuel rate and thus the gas flow.
- Moisture is at ambient level.
- Fuel injection (coal, gas, oil) is at the maximum the furnace accepts, which means the minimum coke rate.
- The top gas temperature is controlled to above 100 °C with oxygen injection.
- The furnace operates symmetrically circumferentially, meaning that all sections representing one tuyere contribute equally to the process (see Section 11.4)
- Casting regime makes process independent from casthouse operation.

6.10 Process symmetry

The process in a blast furnace is very asymmetric: in the radial direction gas flow and composition in the center are very different compared to the wall, which means that different hot metal and slag compositions are simultaneously produced in the center and wall area. Blending of the liquids in the taphole means that these differences cannot be observed. Gas flow in the center has higher temperatures and lower η_{CO} , which can be observed, but is also mixed in the gas system. Around the circumference there can also be deviations in symmetry, resulting from equipment issues, damaged throat armor, different diameter tuyeres with varying amounts of injection and so on.

6.10.1 Radial asymmetry

Gas composition and temperature vary strongly along the radius. In Figure 6.15 the η_{CO} and temperature are shown, as measured with a retractable in-burden probe. In this example, the η_{CO} varies from 10 % in the center to close to 60 % at the wall, and the temperature from 100 °C at the wall to 600 °C in the center.

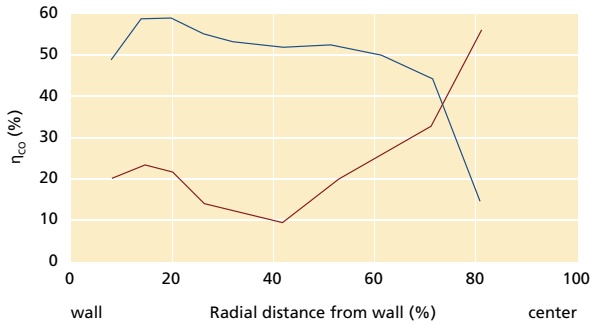

Figure 6.15 Radial asymmetry of η_{CO} and temperature, 6 m below stockline

The burden descend velocity varies over the radius as well. This is to be expected, since the burden descends where the ferrous burden is placed (Chapter VII). An example of radial burden descent is shown in Figure 6.16, as measured in an operating furnace.

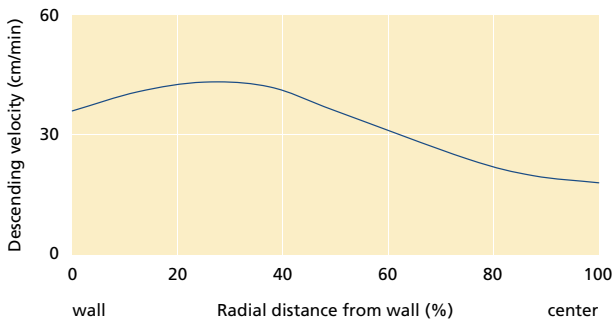

Figure 6.16 Radial descending velocity in an operating blast furnace (2800 m³ IV)

6.10.2 Circumferential symmetry

For high performance all tuyeres have to contribute equally to the process. Consider a tuyere as representing a section of the furnace as shown in Figure 6.17, Example 6.7. If one part of the furnace does not produce the same amount as other parts, the total will suffer. Operators can observe asymmetry in the process from various parameters: for instance, from the burden level: one stock rod at the top gives a different burden level from another; from differences in gas temperatures in the uptakes; from asymmetry in the heat losses; and from differences in hot metal temperature between two tapholes.

6.10.3 Circumferential symmetry of injection, wind distribution

If every tuyere in a blast furnace is considered as part of the blast furnace “pie” and is responsible for the process to the stockline, it is self-evident that the circumferential symmetry of the process has to be assured to reach high performance. This means: symmetrical wind distribution and symmetrical injection of coal and gas.

The various systems in use for PCI have different methods to ensure a good distribution. However, the largest deviation from circumferential symmetry occurs when no coal is injected in a particular tuyere. If no injection is applied, the production rate at that particular tuyere increases substantially (Figure 6.17 and Table 5.5). Consequently, the blast furnace operator has to take care that all tuyeres are injecting coal. In particular, where two tuyeres next to each other are not injecting coal the equalizing effects between the tuyeres are challenged. Especially if the furnace is operating at high PCI rates, the situation is rather serious and short-term actions have to be taken to correct the situation.

The wind distribution is equally as important as the distribution of injectants. Operators tend to work with smaller tuyeres above the tapholes, since a lower production rate above the tapholes stabilizes the taphole mushroom and taphole length. When applying smaller tuyeres, the injectants should be maintained on the tuyeres, otherwise the production increases, even with smaller tuyeres. When replacing a 145 mm tuyere with a 125 mm tuyere the wind volume decreases by 74 %. A similar way of reasoning applies when a tuyere is partially blocked, by slag or ash deposits.

6.10.4 Factors affecting circumferential symmetry

Asymmetry in the process can arise from various sources:

- Asymmetry of the charging. With a bell-less top this can be prevented by changing the rotational direction of the chute and by alternating the coke and ore top bins. Note that the changes have to be made on a time scale smaller than the blast furnace process i.e. every 1–2 hours or 5–11 charges.
- Blast distribution. Blast distribution is affected by plugged or small tuyeres (above a taphole or refractory hot spots) and slag deposits in the tuyere. Asymmetry is also the result of too low blast speeds (under 100 m/s): tuyeres will not function efficiently as blast distributors.
- Worn refractory or throat armor plates at the top of the furnace.
- From uneven coal injection. Especially tuyeres without PCI.
- Deviation of furnace center line from vertical line. This is especially a concern in older furnaces.

Example 6.7 Circumferential symmetry in operation

In Figure 6.17 one tuyere is not injecting coal. What is the effect? As described in Chapter V, one section of the furnace receives more coal and thus has a lower production rate and another section the reverse. As a consequence, the cohesive zone will become asymmetric. This can be observed in heat losses as shown in Figure 6.18, leading to a net shortage on one side of the furnace.

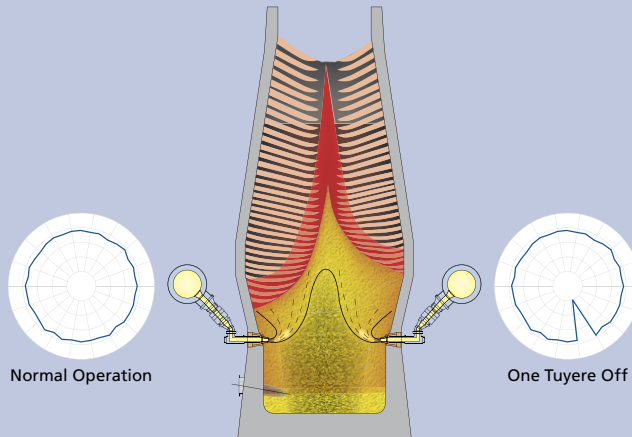

Figure 6.17 Effect of a tuyere without coal injection

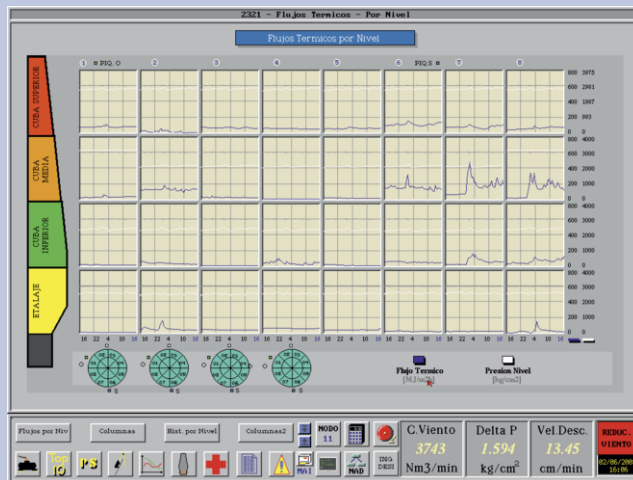

Figure 6.18 24 hrs heat loss distribution (blue). Note a slight process asymmetry. One day graph of eight sections, four levels.

A relatively unknown cause of asymmetry is that the rotation of the chute does not reach perfect symmetry of distribution, for example there is a difference related to the flow from top bins, especially with double hopper systems. Remedial action is to change the rotational direction of the chute frequently, for example every 1–2 hours. Results are shown in an example in Figure 6.19.

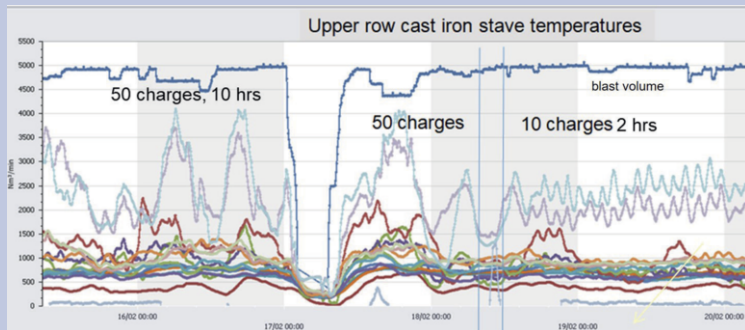

Figure 6.19 Effect of frequency of changing the rotational direction of the chute as shown by the variation of the temperature of the upper row of staves. Change of rotation: left hand every 50 charges (every 10 hours), right hand every 10 charges (every 2 hours).

VII *Burden Distribution*

A blast furnace is a huge gas reactor and the method of choice to distribute the gas over the radius is by making the proper burden distribution. Gas always has the highest flow at the path of least resistance, just as water always flows to the deepest point. For this reason, a separate chapter about burden distribution is required in a book about blast furnace operation.

7.1 The movement of gas and burden

The gas generated at the tuyeres and at the melting zone has a short residence time of 6 to 12 seconds in the blast furnace (Section 2.3). During this period, the gas cools down from the flame temperature to the top gas temperature, from 2000 to 2200 °C down to 100 to 150 °C, while simultaneously removing oxygen from the burden. The vertical distance between tuyeres and stockline is approximately 22 meters. So, the gas velocity in the furnace is rather limited, in a vertical direction about 2 to 5 m/s during the 6 to 12 seconds the chemical reactions take place. The burden descends in the blast furnace from top to bottom. Figure 7.1 shows a representation of the burden descent. It is indicated with mechanical stock rods, which are resting on the burden surface and descending with the burden between charging. The burden surface descends with a speed of 8–15 cm/min.

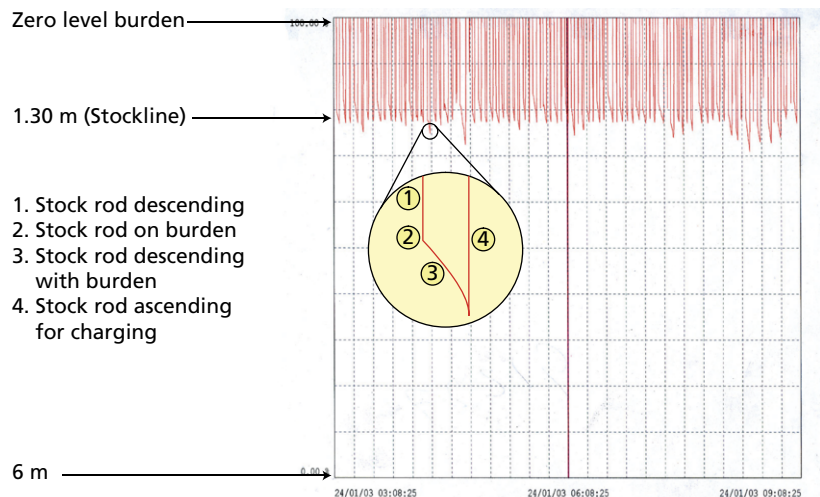

Figure 7.1 *Stable burden descent measured with mechanical stockrods*

In order for the burden to descend, voidage has to be created somewhere in the furnace. Where is this voidage created? (See also Figure 7.2)

- Firstly, coke is gasified in front of the tuyeres, thus creating voidage at the tuyeres.
- Secondly, the hot gas ascends the furnace and melts the burden material. So, the burden volume is disappearing into the melting zone.
- Thirdly, the dripping hot metal consumes carbon. It is used for carburization of the iron, as well as for the direct reduction reactions; so, below the melting zone coke is consumed.

It is possible to indicate how much each of the three mechanisms contributes to the amount of voidage created. A large part of the voidage is generated at the melting zone. In a typical blast furnace with a high PCI rate, only about 20 % of the voidage is created at the tuyeres and less than half of the 300 kg/tHM coke is gasified at the tuyeres.

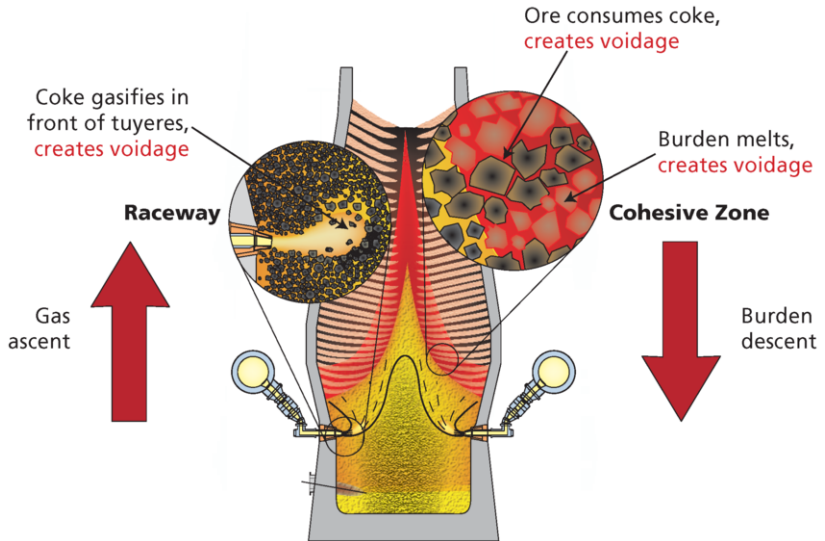
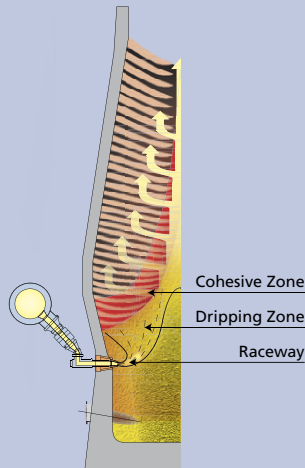

Figure 7.2 Creation of voidage in the blast furnace

The creation of voidage is quantified for the furnace example and shown in Figure 7.3. Example 7.1 shows that the mass flow of material is strengthened towards the ring where the highest amount of ore is charged into the furnace. Therefore, at low coke rates high ore concentration at any ring in the circumference, especially in the wall area, has to be avoided.

Example 7.1 Where and when is voidage generated?

Voidage in a blast furnace is mainly generated where iron ore melts. By melting, the solid ferrous burden becomes liquid and drips down to the hearth. Direct reduction takes place where the burden is melting, as well as carbon dissolution. Most voidage is created where material is melting – only 20 % of the voidage is created by gasifying coke (Figure 7.3).



input		coke	ferrous	total
charged	kg/tHM	300	1570	
specific weight	kg/m ³	550	1800	
+10 % compression	kg/m ³	605	1980	
volume	m ³ /tHM	0.50	0.79	1.29

eliminated		coke	ferrous	m ³ /tHM	%
melting	kg/tHM		-1570	-0.79	62
direct reduction	kg/tHM	-110		-0.18	14
C dissolution	kg/tHM	-52		-0.09	7
Coke gasified	kg/tHM	-137		-0.23	18
Total	m ³ /tHM			-1.29	

Figure 7.3 Creation of voidage as quantified for the reference blast furnace

Another aspect of the voidage in the blast furnace is, that the actual voidage depends on local fluidization of material by the gas flow. If gas flow is locally high, lumps of material are a little farther away from each other than if the gas flow is low. So, compaction of materials is continuously changing. And, of course, the fluidization has an effect on voidage and thus blast pressure.

An example is in Figure 7.4, where the effect of stove changes is shown on blast pressure. Blast furnaces that do not compensate for the additional blast requirement during a stove change, are faced with a slightly lower blast volume into the blast furnace and thus a lower blast pressure. In Figure 7.4b the blast pressure during the minutes after a stove change is shown. Blast pressure for the same blast volume is higher after a stove change and recovers in 5–10 minutes. A similar observation can be made when the furnace is stopped; the burden descends during a stop and voidage decreases. The increase/decrease of voidage can also be seen in the effect of casting.

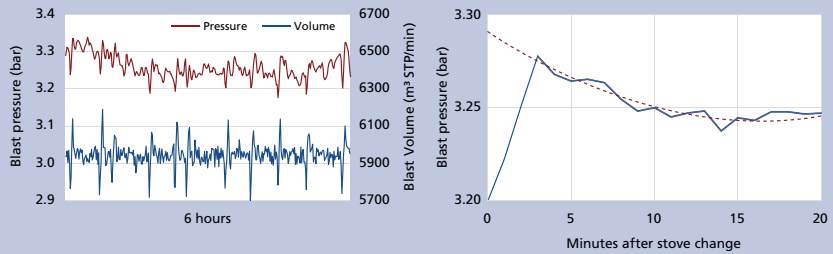

Figure 7.4 Effect of stove changes on blast pressure
 Left: blast volume and pressure for 6 hours showing the stove changes
 Right: the average effect of 7 changes in the 6 hours of left graph

Note that the blast pressure in any blast furnace shows a very high variability. In Figure 7.4 and Figure 7.5 the variability is 0.12 on a total $\Delta P_{\text{process}}$ of 1.2 bar within an hour – and half of it occurs within minutes. 0.12 bar means that voidage varies by 5%. Compared to different industrial processes, like direct reduction plants or air separation units, the variability is extreme. The blast furnace is extreme, because voidage can vary because of blockage or the opening of coke slits with liquids.

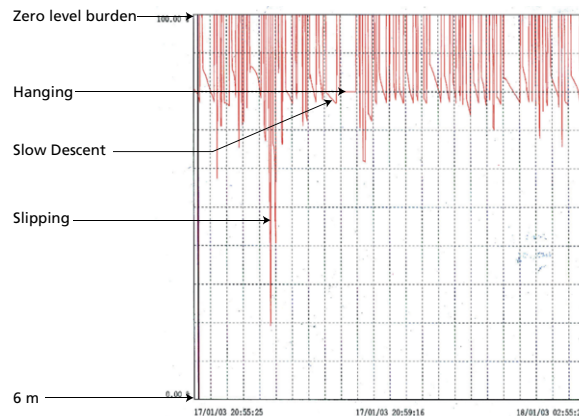

Figure 7.5 Irregular burden descent

Sometimes the burden descent of a blast furnace is erratic. What is the mechanism? Cold burden materials and coke flow rather easily through bins, as can be observed in the stock house of a blast furnace. Hence in the area in the blast furnace where the material is solid, the ore burden and coke flow with similar ease to the void areas. Nevertheless, blast furnace operators are familiar with poorly descending burden (Figure 7.5).

Also, the phenomenon of “hanging” (no burden descent) and “slips” (fast uncontrolled burden descent) are familiar. From the analysis in this section it follows that, in general, the cause of poor burden descent must be found in the configuration of the cohesive zone. The materials “glue” together and can form internal bridges within the furnace. Poor burden descent arises at the cohesive zone. The effect of a slip is that the layer structure within the furnace is disrupted and the permeability for gas flow deteriorates (Chapter XII).

7.2 Burden descent: system of vertical forces

The burden descends because the downward forces of the burden exceed counteracting upward forces and push material into the voidage that is created. This idea has in particular been developed by Cor van der Vliet, co-author of the 1st and 2nd editions of this book. The most important downward force is the weight of the burden; the most important upward force is the pressure difference between the blast and top pressure or, to be more precise: the pressure difference between the lower side of the cohesive zone and the top $\Delta P_{\text{process}}$ (Figure 7.6). Most operators, however, are used to the total ΔP between hot blast pressure and top pressure.

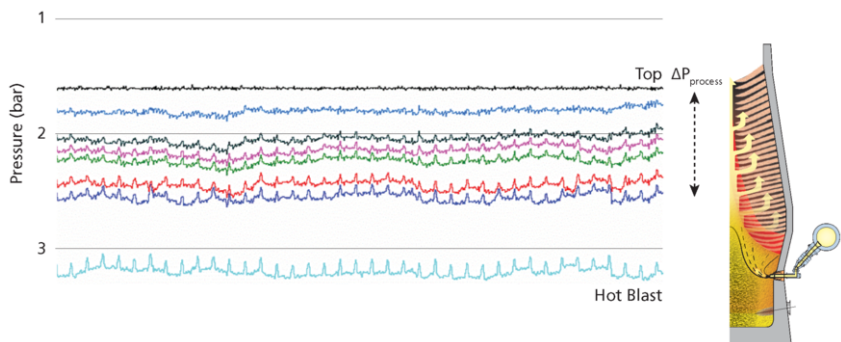

Figure 7.6 Pressure difference in a blast furnace, the upward pressure is the $\Delta P_{\text{process}}$

The cohesive zone is an area with high resistance to gas flow, since cohesive material is impermeable to gas and the coke slits fill up with melting slag and hot metal. It leads to a large pressure drop over the cohesive zone and to a large upward force. The upward and downward forces are estimated for the example furnace and shown in Figure 7.7 on the following page.

The coke submerged in hot metal also exerts a high upward force on the burden due to buoyancy forces (Figure 7.8), as long as the coke is free to move upwards and does not adhere to the bottom. In the figure it was calculated as coke submerged in 1 meter of hot metal. In addition to the upward force arising from the blast pressure, friction forces from the descending burden influence burden descent: the coke and burden are pushed outward over a cone of stationary or slowly descending central coke. The wall exerts frictional forces on the burden.

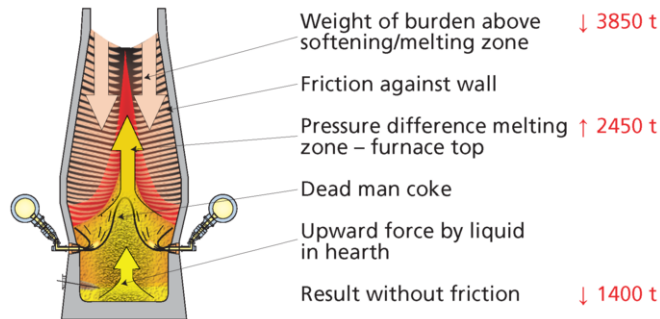

Figure 7.7 System of vertical forces in the blast furnace

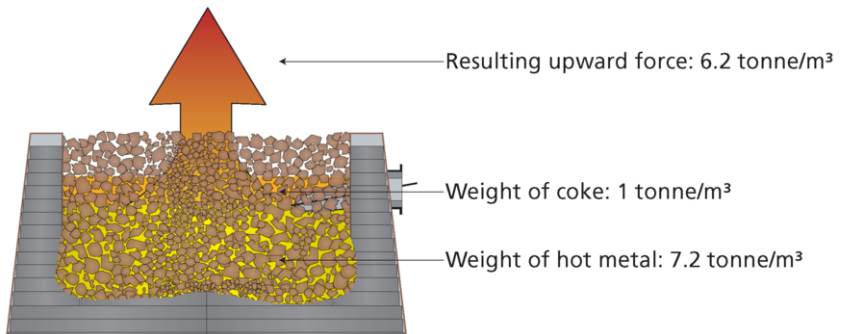

Figure 7.8 Upward force from hearth liquids

In operational practice poor burden descent is often an indicator of a poor blast furnace process, especially difficulty in consistent melting of ferrous materials.

The reasons for poor burden descent can be:

- The upward force is too high. Experienced operators are well aware of the maximum pressure difference over the burden that allows smooth operation. If the maximum allowable pressure difference is exceeded (generally 1.6 to 2 bar), the process is pushed beyond its capabilities: burden descent will become erratic, resulting in frequent hanging, slipping and chills.
- A hot furnace is also known to have poorer burden descent. This is because the downward force decreases due to the smaller weight of burden above the melting zone. In addition, there is more slag hold-up above the tuyeres, because of the longer dripping distance to the hearth and the (primary) slag properties.

- Burden descent can be very sensitive to casthouse operation because of the abovementioned upward force on the submerged coke. A high liquid level in the hearth creates greater buoyancy forces.

7.3 Burden distribution and gas flow control

7.3.1 How does gas pass through ferrous layers?

The total ΔP in the furnace in Figure 7.4 is typically around 1.6 to 2.0 bar, of which 0.3 to 0.5 bar is caused by the tuyeres (Figure 6.8), which function as a restriction. So, the ΔP of the blast furnace process is 1.2 bar. Since there are 30 to 40 charges in the blast furnace, the ΔP over 1 charge is 0.03–0.04 bar or 30–40 cm water gauge. There is a large difference in permeability between the coke layers and the ore burden layers. The ore burden has a much higher resistance to gas flow than coke. As a consequence, the horizontal coke layers have the same pressure over the diameter, and it is the pressure difference of 0.03–0.04 bar between sequential coke layers that drives gas through the ferrous layers (Figure 7.9).

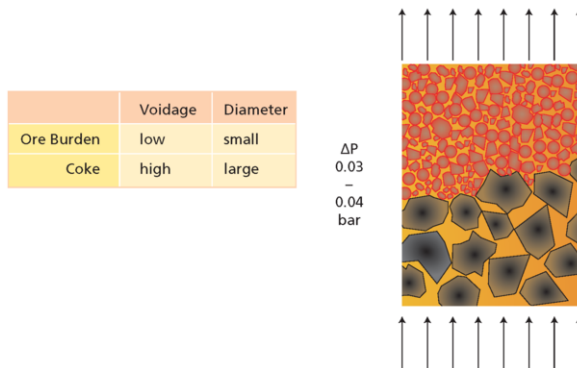

Figure 7.9 The pressure difference between sequential coke layers drives gas through the ferrous layer

The required pressure to drive the gas through the furnace is determined by the permeability of the ore burden, which is determined by the amount of fines and its melting properties. The amount of fines is determined by:

- The screening efficiency in the stock house.
- The physical degradation during transport and charging.
- The low temperature degradation properties of the burden. These effects cause a ring of burden material with poor permeability in many operating blast furnaces. This ring of material, in particular, is often difficult to reduce and to melt down. Sometimes, unmolten ore burden materials are visible as scabs through the peepsights of the tuyeres. The unmolten material can cause operational upsets like chilling the furnace or tuyere failures. It is a misunderstanding to think that these scabs consist of accretions that have fallen from the wall.

7.3.2 Objectives of burden distribution

In a blast furnace oxygen is removed from the ferrous burden by two different mechanisms: reduction by gas (CO and H₂) and “direct reduction”, which results in carbon used for direct reduction. Both mechanisms have to take place, as explained in Annex IV, but in operating blast furnaces, improving gas reduction always leads to lower fuel rate, which is manifest from improved gas efficiency or η_{CO} . Technically: in order to reduce wustite, FeO, by CO, the η_{CO} on the wustite level has to be below 30 % in order for sufficient CO to be present (Annex IV). In operational practice the value at very good operating furnaces does not exceed 25 %. This means gas reduction does not reach its thermodynamic limits.

So, the objective of burden distribution is to maximize gas reduction. To this end, the reduction gas has to be distributed evenly through the ferrous layers. The unfortunate aspect of blast furnace operations is that ferrous burden impedes gas flow because of its higher resistance compared to coke. In order to make the gas flow as even as possible, the following conditions have to be met:

1. The ferrous layer needs to have a uniform thickness over the radius, because a thicker layer on a certain radial position will impede gas flow.
2. The ferrous fines have to be blended well through the ferrous burden, because fines impede gas flow.
3. Various materials have to be blended well in order to avoid radial differences in permeability. It may be clear that at a radial position with good permeability, for instance with a large pellet percentage, gas will flow through this area, resulting in very well reduced pellets, but poor reduction will then occur at the radial positions that have less gas throughput.

The situation is made more complicated in a blast furnace because

1. Gas can easily flow along the wall.
2. Softening and melting materials are impermeable for gas, which means that in the cohesive zone gas has to flow through the coke slits (or along the wall).

Gas flow along the wall is shown by heat losses through the cooling system of stave temperatures in Figure 7.10. These are caused by hot gas in direct contact with the staves. The general pattern is, that stave temperatures increase fast in 5–20 minutes and then decrease more slowly over several hours.

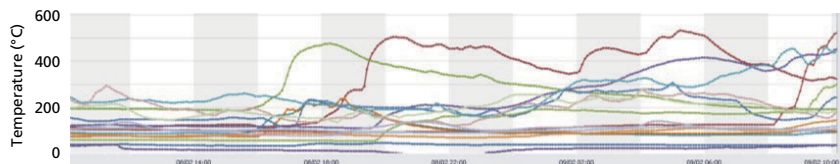

Figure 7.10 Example of stave temperatures

Gas has to flow through the cohesive zone via the coke slits. The pressure needed to drive gas through the coke slits depends on:

1. The amount of gas per unit time, minute for instance: at high productivity more gas has to pass through the coke slits than at low productivity.
2. The number of coke slits and width of the coke slits: at high coal injection rates the number and/or width of the coke slits becomes smaller.

7.3.3 Two basic types of cohesive zone

The efficiency of the furnace is determined by the amount of energy used in the process. Heat losses to the wall and excess top gas temperature are examples of energy losses. The top gas contains CO and H₂, which have a high calorific value, therefore, the efficiency of a blast furnace is determined by the progress of the chemical reactions and thus by the gas flow through the furnace.

Two basic types of gas distribution can be distinguished: the “central working” furnace and the “wall-working” furnace. The typology has been developed to explain differences in operation. Intermediate patterns can also be observed. In the “central working” furnace the gas flow is directed towards the center. In this case the center of the furnace contains only coke and coarse burden materials and is the most permeable area in the furnace. The cohesive zone takes on an “inverted V shape”. In a “wall-working” furnace, the gas flow through the center is impeded, e.g. by softening and melting burden material. The gas flows preferentially through the zone with highest permeability, i.e. the wall zone. In this case the cohesive zone takes the form of a “W shape”. Figure 7.11 shows both types.

Both types of gas flow can be used to operate a blast furnace, but each has its own drawbacks. Gas flow control is achieved by burden distribution.

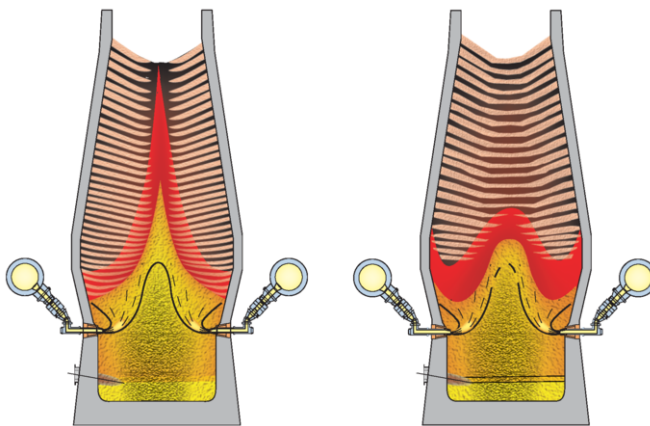

Figure 7.11 Two types of melting zone: “inverted V shape” for a central working furnace (left) and “W shape” for a wall-working furnace (right)

7.3.4 Central working furnace

The two types of gas flow through a furnace can be achieved with the help of the burden distribution. In Figure 7.12 the ore-to-coke ratio over the radius is shown for a central working furnace. In the figure, the center of the furnace contains only coke. So, in the center of the furnace no melting zone can be formed, and the gas is distributed via the coke slits from the center towards the outside radius of the furnace. The melting zone gets an inverted “V” or even “U” shape. The central coke column not only serves as a gas distributor, but also as a type of pressure relief valve: it functions to stabilize the blast pressure.

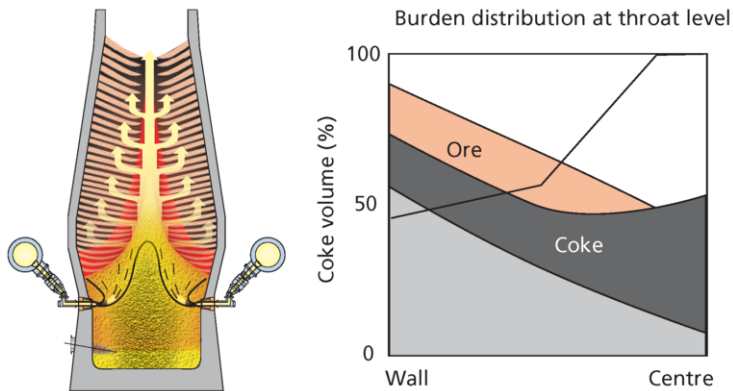

Figure 7.12 Central working furnace

The type of burden distribution equipment determines how the coke can be brought to the center. With a bell-less top the most inward positions or lowest angles of the rotating chute can be used. With a double bell system, the coke has to be brought to the center by “coke push” (see below) and by choosing the right ore layer thickness in order to prevent flooding of the center with ore burden materials. In the central working furnace, there is a relatively small amount of hot gas at the furnace wall: hence low heat losses. As a result, the melting of the burden in the wall area takes place close to the tuyeres, so the root of the melting zone is low in the furnace. The risk with this type of process is that ore burden may not be melted completely before it passes the tuyeres. This could lead to the observation of lumps of softened ore burden through the tuyere peepsights. This can lead to anything from slight chilling of the furnace (by increased direct reduction) and irregular hot metal quality up to severe chills and damage to the tuyeres.

Limiting the risk of a low cohesive zone root can be done with gas and burden distribution. Operational measures include the following.

- Maintain a sufficiently high coke percentage at the wall. Using nut coke in the wall area can also do this. Note that an ore layer of 78 cm at the throat needs about 28 cm of coke for carburization and direct reduction. So, if the coke proportion at the wall is under 27 %, a continuous ore burden column can be made at the wall.

- Ensure a minimum gas flow along the wall in the bosh and belly, which can be monitored from heat loss measurements and/or temperature readings. If the gas flow along the wall becomes too small, it can be increased by means of burden distribution (more coke to the wall or less central gas flow) or by increasing the gas volume per tonne of hot metal (by decreasing oxygen).
- Control the central gas flow. Note that the gas flow through the center leaves the furnace at a high percentage of CO and H₂ and a high temperature. The energy content of the central gas is not efficiently used in the process, and so the central gas flow should be kept within reasonable limits.

The central working furnace can give very good, stable process results with respect to productivity, hot metal quality and reductant rate. It also leads to long campaign length for the furnace above the tuyeres. However, the process is very sensitive to deviations in burden materials, especially size distribution. A big increase in coke rate due, for example, to problems with PCI preparation, may need a change in coke distribution to avoid excessive central coke, which can then starve the wall region of gas.

7.3.5 Wall-working furnace

Figure 7.13 shows the wall working furnace. If ore is charged into the center, melting ore burden blocks the center of the furnace and the gas flow is directed towards the wall area.

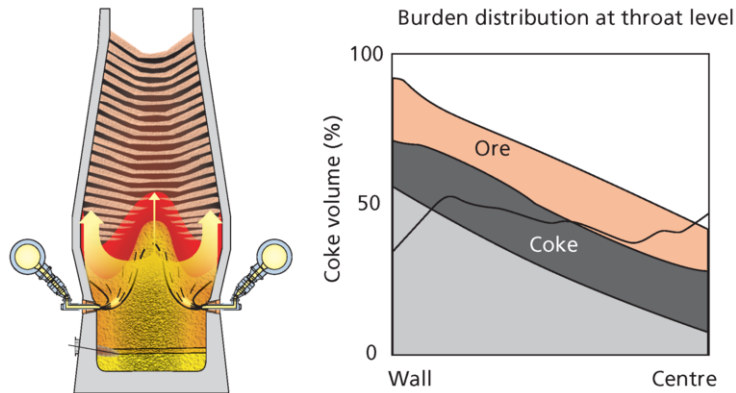

Figure 7.13 Wall-working furnace

The gas flow causes high heat losses in the area of the furnace where a gap can be formed between burden and wall i.e. in lower and middle shaft. The melting zone gets a “W” shape or even the shape of a horizontal disk. In this situation the root of the melting zone is higher above the tuyeres, which makes the process less sensitive to inconsistencies. The process can be rather efficient. However, due to the high heat losses, the wear of the refractory or damage to cooling staves or plates in the shaft, is much more pronounced than with the central working furnace. The gas passing along the wall can also cool down

rapidly and in doing so loses its reduction capabilities. As a consequence, the fuel rate is high. Moreover, the fluctuations in the pressure difference over the burden are more pronounced, and this leads to limitations in productivity.

7.3.6 “Ideal” burden distribution

The ideal burden distribution for high productivity and high PCI rates is, according to the authors, as follows (Figure 7.14):

- An ore-free center,
- Nearly horizontal layers of coke and ore burden,
- Some nut coke in the ore burden in the wall area and
- Fines distributed over the radius.

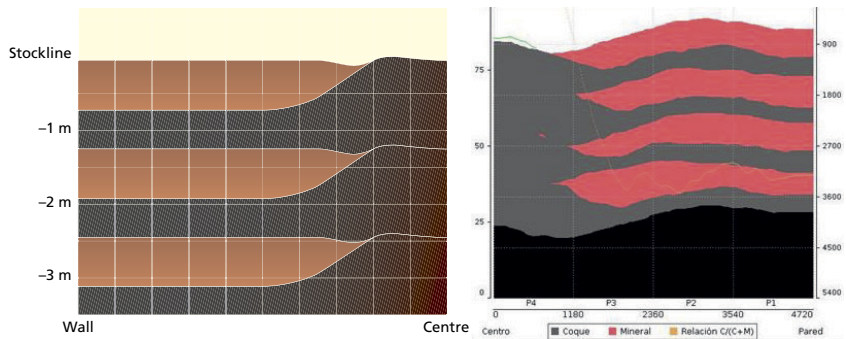

Figure 7.14 “Ideal” burden distribution (left) and operational practice as measured with profile measurements of close to ideal burden distribution (right)

Ore-free center

The ore free center allows the gas to distribute itself through the coke layers from the center to the wall. We can consider the coke layers as layers with equal pressure. If the total internal pressure difference is 1.2 bar, the pressure difference over each of the 30–40 ore layers is about 0.03–0.04 bar. The ore-free center typically has a diameter of 15–20 % of the diameter. The ore-free center can be made in a furnace with a bell-less top by discharging 15–20 % of the coke on a very inward chute position. The center coke can also be discharged as a separate dump.

The coke charged in the center is attacked least by the solution-loss reaction and has the smallest chance of being burnt in front of the tuyeres. For this reason, it is thought that the coke charged in the center finally constitutes the coke in the hearth. Good permeability of the hearth helps to improve casting and prevents preferential flow of iron along the wall, thus increasing hearth campaign life.

Nearly horizontal layers

Using nearly horizontal layers of coke and ore minimizes the effect of natural deviations of parameters. For instance,

- sinter and pellets have different angles of repose.
- wet pellets have a larger angle of repose as compared with dry pellets.
- stockyard material has a smaller angle of repose as well as more fines than fresh materials.

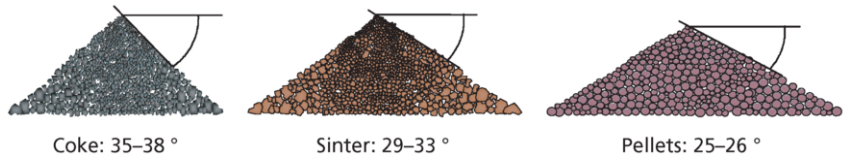

Figure 7.15 Segregation and angles of repose.

Figure 7.15 shows the angles of repose of the various materials used in a blast furnace. Coke has the steepest angle of repose; pellets have the lowest angle of repose and sinter is in between. Hence, in a pellet charged furnace the pellets have a tendency to roll to the center. Fines concentrate at the point of impact and the coarse particles flow “downhill”, while the fine particles remain below the point of impact. The result is fine material at the center and coarse material at the foot of the conical pile

Nut coke

The gas in the wall area is cooled by the heat losses to the wall. Moreover, a relatively large percentage of fine ore burden material is located at the wall, and reduction–disintegration is highest at the wall (because of slower heating and reduction). For these reactions, reduction and melting of the ore burden in the wall area is most difficult. Nut coke in the wall area helps to lower reduction gas and heat requirements in the wall area. The nut coke has a lower heat capacity than the ore burden. Moreover, when the ore burden in the wall area starts melting, the nut coke is immediately available for direct reduction. In this way, it prevents direct reduction attack on the metallurgical coke.

Fines distributed over the radius

During discharge of the ferrous materials, fine material is discharged at the lower part of the falling curve (Figure 7.16 on the next page). As a consequence, if several rounds of the chute are maintained at the same chute angle, the fines are collected above each other in a ring, and this makes that specific ring less permeable. Segregation is minimized by using a large number of chute angles (more than 8 positions) and distributing the ferrous burden in horizontal layers with a minimal discharge time (less than 12 rings).

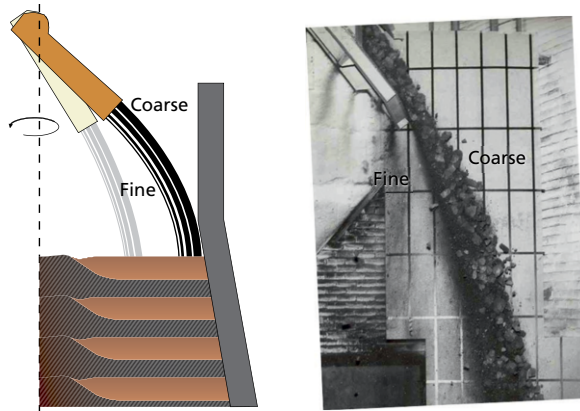

Figure 7.16 Segregation of fine material in a chute (left) and as shown in a laboratory test with coke

Coarse and fine sinter

Some companies separate coarse and fine sinter and charge the materials separately, for example as in Figure 7.16. The good aspect of the method is that the furnace suffers less from mixed layers (see Section 7.4), since coarse sinter does not penetrate well into the coke. The disadvantage is that there are relatively large ferrous layers.

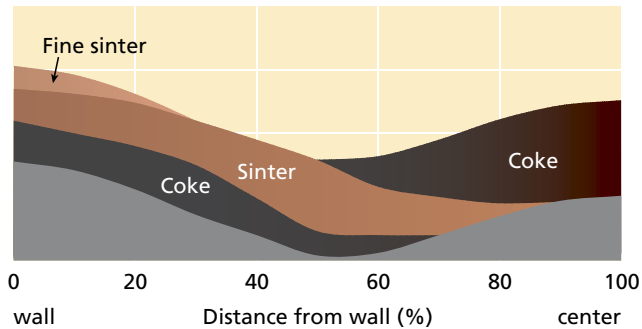

Figure 7.16 Burden profile with coarse and fine sinter

Example 7.2 Example: from W shape to inverse V shape cohesive zone

An example of a furnace changing over from “W shape” cohesive zone to an “inverse V shape” (central working) is shown in Figure 7.17. In an 1800 m³ IV furnace, 19 % of the coke was charged into the center, with the chute starting in the center for coke (moving from center to wall) and the ferrous burden charged from outside inwards. Heat losses fell from 50 GJ/hr to 30 GJ/hr, and the furnace became more stable and productive within 24 hours. The top camera showed a relatively cold spot in the center before the change, which disappeared after the change.

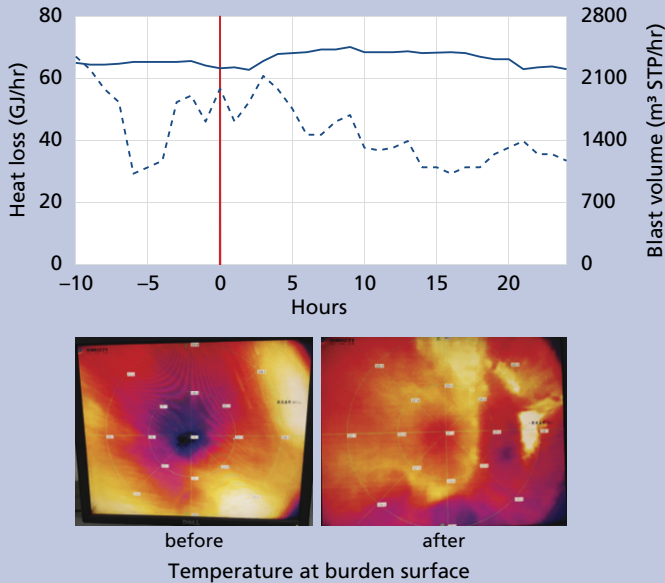

Figure 7.17 Effect of charging coke into the center. At 0 hrs, 19 % of coke was charged into the center. Dotted line represents heat loss, drawn line blast pressure. Details in text.

7.4 Coke and ore layer thickness

The ratio between coke and ore layer thickness is dependent on the coke amount charged per tonne in the top. For permeability: the thicker the coke layer and the more permeable the coke (large coke), the better the permeability. For reduction of the ferrous layer: the thinner the ferrous layer, the better the contact between gas and the ferrous burden and the better the reduction.

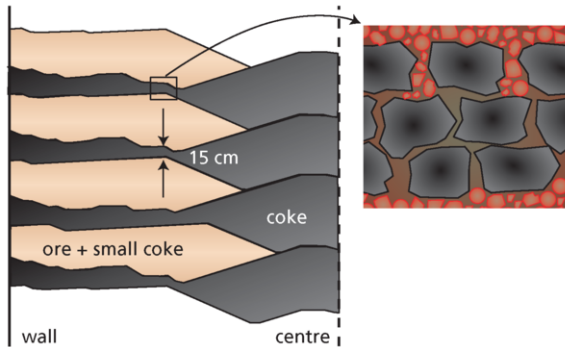

Figure 7.18 Mixed layer formation

What determines the optimum ferrous layer thickness? First consider formation of a “mixed layer”. The average diameter of coke (40 to 50 mm) is much larger than that of pellets and sinter (typically under 15 mm and 25 mm respectively). Burden components dumped on a coke layer will tend to form a “mixed layer” (Figure 7.18). This mixed layer will have permeability comparable with the ore layer. The larger the coke and ferrous layer thicknesses, the fewer mixed layers are present in the furnace. However, very thick ferrous layers are difficult to reduce (Figure 7.19). The thicker ore layers heat up more slowly and have poorer gas reduction. When the layers are softening, a very thick cohesive zone is formed, which melts from the surface. Thicker layers are also more difficult to melt, so for permeability, thick coke layers are required, but for good reduction and melting, thin ferrous layers are to be preferred.

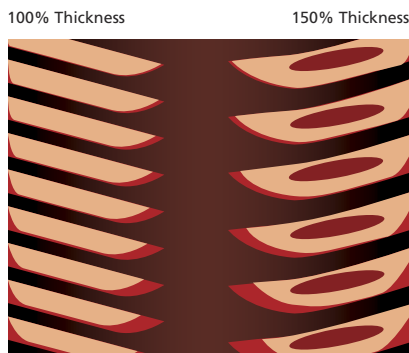

Figure 7.19 Reduction of thin and thick ore layers

7.4.1 Ore layer thickness

Figure 7.20 shows a benchmark of the ferrous layer thickness used in operating blast furnaces. The results indicate that the optimum layer thickness also depends on quality and type of raw materials, screening in the stockhouse, charging capacity, productivity and injection rate.

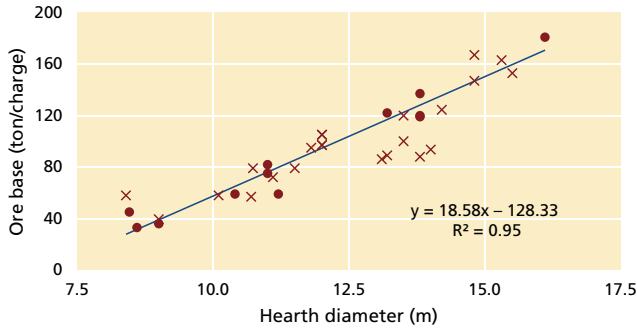

Figure 7.20 Ferrous layer thickness expressed as tonne ferrous/charge versus hearth diameter. Red dots represent blast furnaces that perform excellently.

7.4.2 Coke layer thickness

Coke layers separate the ore layers. While the ore is melting, the ferrous layers have to be prevented from making contact with each other, causing the formation of scabs. Example 7.3 presents operational examples, where the coke layers between the ferrous layers become too small. It can cause poor permeability, erratic burden descent and/or tipping tuyeres.

In order to prevent contact between the ferrous layers, coke required for direct reduction and carburization has to be present. This can be estimated as in Figure 7.21. The amount of coke required to prevent ferrous layer contact is about 25 % of the volume. The coke requirement at the wall can also be met using nut coke blended into the ore layer. In this case, the nut coke is preferentially available for direct reduction and will preserve the larger, metallurgical coke in the layer structure.

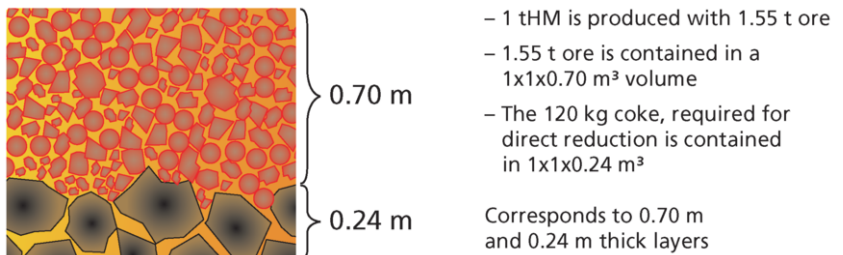

Figure 7.21 Coke required for direct reduction including carburization

Contact between ferrous layers will lead to disturbed gas flow. There is also a risk that unmolten material will rest on the tuyere nose and cause the tuyere to tip. This can be observed through the peepsight where an oval opening of the tuyere is seen rather than a round one.

7.4.3 Minimum coke rate

When reaching higher and higher coal injection levels the question arises whether a minimum coke layer thickness exists, and what would it be? The gas ascending the furnace from the tuyeres to the top is distributed through the coke layers, so the coke layers must be present at all elevations of the furnace for this to continue. As the layers are made up of discrete coke particles, the theoretical minimum coke layer thickness translates into a number of coke particles. To produce a path for the gas it is believed that the minimum number of coke particles that should be present in the height of one layer is three. The minimum thickness is therefore three times the mean size of coke in the belly of the blast furnace. Taking an average coke size of 50 mm, it would therefore be reasonable to expect that the minimum coke layer thickness in the belly is 15 cm. As the effective ratio of the surfaces of belly to throat is generally around 2.25, the coke layer thickness at the throat should be at least about 34 cm.

In operational practice at furnaces operating at high coal injection levels, the coke layer thickness at the throat has reached values as low as 32 cm and in the belly 14 cm.

The minimum “metallurgical” coke rate (this is the coke rate excluding nut coke), as a monthly average for operating blast furnaces, has reached levels of 210–220 kg/tHM in the best months and 230–240 kg/tHM as a longer term average for well-operated blast furnaces.

7.4.4 Optimizing ore and coke layer thickness

The blast furnace operator wants good permeable coke layers (i.e. thick layers) and good melting ore layers i.e. thin layers. As is often the case in blast furnace operation the best operational results can only be reached with a compromise between these two factors. Generally speaking, from operational observation, the ore layers should not exceed 70–80 cm in the throat of a blast furnace, and coke layers should not be smaller than 34 cm. The operational optimization depends on local situations.

Experience has shown that:

- Permeable ore layers can be maintained even when the layers have become quite thick, provided a permeable ore burden is used. For pellet burdens this would require screening of the pellets, and for sinter it would have to be sized to a relatively large diameter (more than 5 mm).
- The minimum coke layer thickness experienced was 14 cm metallurgical coke in the belly.

Conveyor belt fed furnaces tend to work with thicker ore layers. This is caused by the fact that in a conveyor-fed furnace the charging capacity increases with increasing layer thickness. In skip-fed furnaces the optimum charging capacity is reached with full skips of coke. In the past the volume of coke was normally the determining factor, so furnaces tended to work with full skips of coke. At high coal injection rates, the skip weight is normally the determining factor and thus furnaces now work with full skips of ore.

Another aspect of the optimization of the coke layer thickness has to do with the gas permeability of the coke layer. The coarser the coke is screened in the blast furnace stockhouse, the more permeable the layer is. There are, however, two drawbacks to the coarse (35 mm or more) screening of coke.

Consequence 1: The coarser the coke is screened, the more nut coke or small coke is produced. The nut coke is added to the ore burden layer, increasing the its thickness and decreasing that of the coke layer.

Consequence 2: The coarser the coke is screened at the stockhouse, the thicker the formation of a mixed layer at the coke-burden interface.

7.5 Finding an optimal burden distribution

It can take many years to find good burden distribution for a furnace. But if found, it can be quite stable for many years with slight and controlled steps in burden distribution.

Companies with proper instrumentation for analysis of burden distribution, like a profilometer and burden distribution model, have generally succeeded in achieving efficient operation.

Blast furnaces operated without these tools have greater difficulty in optimizing burden distribution. In operational practice the following misunderstandings have been observed by the authors.

1. In the event of high heat loads through the wall, operators sometimes tend to charge more ferrous at the wall. This can help but more often the furnace receives a coke percentage that is too low at the wall, thus making the situation worse. Note that gas in a blast furnace always takes the path of least resistance, so the solution for high heat loads is adjusting the resistance pattern in the furnace, for instance by charging central coke.
2. Sometimes the operator is forced to aim for high productivity. Excessive amounts of coke in the center (> 25 %) and high oxygen enrichment with a low top temperature (below 80–90 °C) are used. Note that this is an average – it will be even lower over the outer radius, indicating insufficient gas flow. Furnace efficiency declines ($\eta_{\text{CO}} < 44\%$). More details in Section 11.1.2.
3. Operators are trying to improve permeability and lower the heat loads to the wall by increasing the central gas flow. The method of choice is to move the

distribution of coke and ferrous to the furnace center. This can lead to an “inverse profile” (i.e. a profile where the central area is higher than the wall). To our knowledge, the inverse profile has not been applied successfully and should therefore be avoided at all times. This method is an extrapolation of the burden distribution control used in the past with double bell equipped furnaces. Finding that central gas flow could be increased by extending a platform at the wall and making the V-shaped center smaller was an extremely fruitful research outcome. The method is sometimes referred to as “platform–V” burden distribution. It was extremely useful for double bell furnaces, but not applicable or obsolete for furnaces with a bell-less top.

7.6 Double bell furnaces

Furnaces operating with a double bell top have less flexibility in burden distribution. The following points are of importance for these furnaces.

- As shown in Figure 7.22, material charged from a double bell segregates into fine and coarse material, forming rings of fine materials that are poorly permeable for gas. These materials melt relatively poorly and can become visible as scabs through the peepsights. In the event that movable armor is available, the radial location of the ring of fines can be varied, which improves the gas reduction and furnace efficiency and decreases the frequency of scabs at the tuyeres.
- The central coke in the furnace comes from the “coke push” effect (Figure 7.22). Coarse coke on the surface of the coke layer is pushed towards the center upon charging of the next ferrous layer. The central gas flow can be controlled by controlling the amount of ferrous burden that reaches the center. This can be done using three different methods.
 - a. Creating and extending a platform at the wall with movable armor positions. On an extended platform more ferrous is held at the wall and less ferrous reaches the center.
 - b. By varying the layer thickness (weight) of the ferrous burden. If the batch weight of the ferrous is decreased, for every charge the same coke amount is still pushed towards the center, but less burden reaches the center.
 - c. Coke charged first on the double bell before ferrous will be pushed towards the center.

Operators have developed additional methods to influence gas flow for a double-bell blast furnace. These methods have to do with the charging sequence of coke and ferrous, the stockline level and the opening speed of the double bell. There is often considerable experience with these types of methods on site, but application is very furnace-dependent.

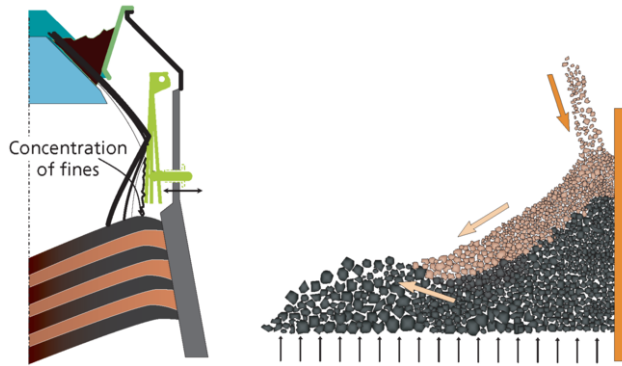

Figure 7.22 Burden charging with double bell top

7.7 Permeability of cohesive zone

Materials soften and melt in the temperature range of 1200–1400 °C as shown in Figure 7.23a. Softening materials are impermeable to gas: in Figure 7.23b shown by a sample of burden consisting of 100 % pellets taken from a blast furnace after blowdown, and in Figure 7.23c by a sinter sample during a melting test. If nut coke is added to the sinter, the nut coke remains intact and can create paths for gas to pass (Figure 7.23d). For this reason, the cohesive zone becomes more permeable with nut coke, which makes the cohesive zone melt ore easily. The cohesive material breaks into smaller pieces when descending into voidages, and helps to promote smoother burden descent, especially if charged in the wall area.

Since scrap has a high melting temperature, it also remains solid in the temperature range of the cohesive zone, so scrap has a similar effect to nut coke on the permeability and melting of the cohesive zone.

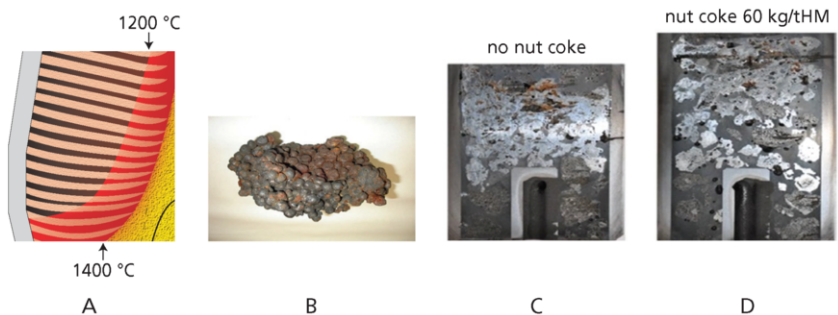

Figure 7.23 A: cohesive zone; B: softened pellets sampled from a furnace; C: sinter during melting test; D: same as C with nut coke added (C and D from Quinshi Song, 2013)

Example 7.3 Operational challenges and burden distribution solutions

Radial nut coke position, 4600 m³ blast furnace

In an operating blast furnace burden descent was poor (Figure 7.24, left). This improved greatly after bringing nut coke from the intermediate to the wall area (Figure 7.24, right). Explanation: operator moved ferrous outwards to control high heat loads to the wall, but exceeded the limit where ferrous burden at the wall started to become vertically connected.

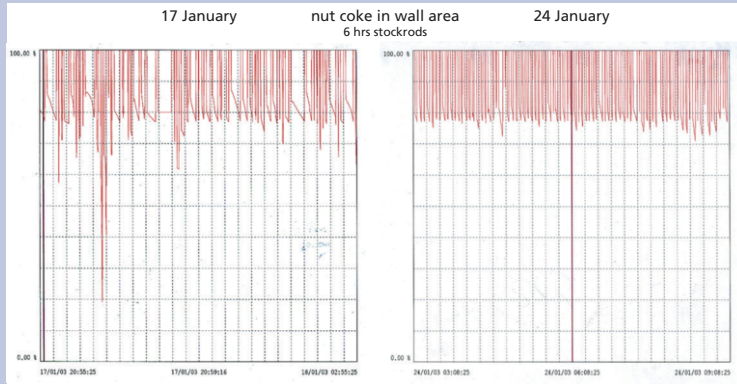

Figure 7.24 Stockrods, 6 hour graphs, before and after moving nut coke to wall

Inverse profile, 2800 m³ furnace

Because of tuyere tipping, the operator wanted to charge more coke at the wall, which was executed by moving pellets (100 % pellets furnace) inwards. This caused an inverse profile with a very large pellet percentage at the wall because of the shallow angle of repose of pellets (Figure 7.25). The result was more severe tipping. Solved by moving coke and pellets towards the wall.

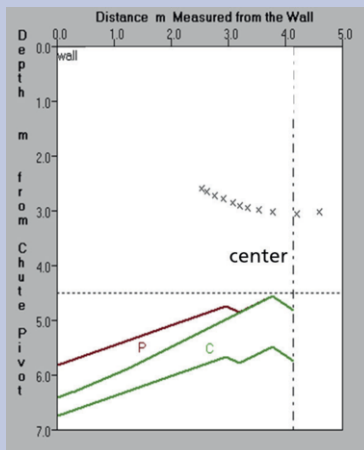

Figure 7.25 Inverse profile at 100 % pellet furnace

Inverse profile, 5000 m³ furnace

In order to improve central gas flow and decrease heat loads to the wall, coke and ferrous layer were shifted inwards. The burden profile as calculated by the plant research showed an inverse profile, see Figure 7.26.

At about 2.2 m from the center, the coke percentage was very low. On melting, a vertical column of cohesive material was formed without coke slits. This caused poor permeability. After a horizontal profile was implemented, the furnace had lower heat loads and was accepting higher pellet percentage.

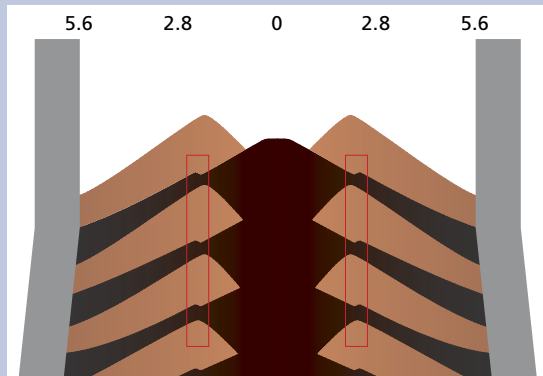

Figure 7.26 Inverse profile with very low coke percentage 2 meters from the center, resulting in cylinders of melting ferrous material in and below the cohesive zone

This page intentionally left blank

VIII *Hot Metal and Slag*

How is the ferrous burden transformed to hot metal and slag? In the preceding chapter gas flow through the furnace was discussed. The present chapter shows how the gas affects burden, first in the “dry” area above the cohesive zone, then softening, melting and finally how hot metal and slag reach the final composition and properties.

8.1 **Processing the ferrous burden above the cohesive zone**

Ferrous burden is the collective term used to describe the iron-containing materials that are charged to the furnace, namely, sinter, pellets and lump ore. The melting properties of these materials depend on the local chemical slag composition. Lump ore has its natural slag composition as it is found in the earth, gangue consists mainly of acid components like SiO_2 and Al_2O_3 . Pellets and sinter have an artificial composition with components added to the natural iron ores, such as limestone (CaCO_3), dolomite ($\text{MgCO}_3 \cdot \text{CaCO}_3$), olivine ($2\text{MgO} \cdot \text{SiO}_2$) and others. Sinter basicity CaO/SiO_2 is typically above 1.6 and can even reach levels of 2.8 or higher. Pellets have a wide variety of chemical compositions, most notably acid pellets ($\text{CaO}/\text{SiO}_2 < 0.2$) or fluxed pellets ($\text{CaO}/\text{SiO}_2 > 0.8$).

The chemical composition of the materials is not only based on the design of the optimum properties of the final slag, with respect to melting temperature, fluidity and desulfurizing properties, but also on the design of the metallurgical properties of the sinter and the pellets. Optimal metallurgical properties mean that the materials should have good reduction–disintegration properties and melting temperatures as high as possible. The reason for these requirements is defined by the nature of the blast furnace process, this being a gas–reduction process. If the material breaks down into small particles, the gas flow through the ore layer is impeded and the normal reduction process is limited. In addition, materials which start to melt form an impermeable layer and will also affect the reduction progress.

Note that the efficiency of a blast furnace is largely determined by the gas reduction process, along with the amount of oxygen bound on the iron, which is removed by gas (CO and H_2).

8.1.1 Reduction from hematite to magnetite and reduction–disintegration

The reduction process starts at temperatures of about 500 °C in the atmosphere of a reducing gas, that is, the blast furnace top gas. The reduction of hematite (Fe_2O_3 , O/Fe = 1.5) to magnetite (Fe_3O_4 , O/Fe = 1.33) takes place rather easily and generates a small amount of heat. In hematite, 6 atoms of iron are bound to 9 atoms of oxygen, which changes to 8 atoms of oxygen upon transition to magnetite. The extra oxygen is bound to the CO gas, forming CO_2 .

The first step in the reduction process has a profound effect on the properties of the ferrous burden. The crystal structure where 6 iron atoms and 9 oxygen atoms were happily conjoined is forced to change to 6 iron atoms on 8 oxygen atoms. The crystal structure changes with an associated volume increase of about 10 % and this leads to stress within the particles, which can fall apart. This is called reduction disintegration, and is represented by the Reduction Disintegration Index (RDI) or, sometimes by Low Temperature Breakdown (LTB, Chapter III). Note that the reduction disintegration generates a huge amount of fines. After screening, sinter has 2–4 % of fines (smaller than 5 mm); reduction disintegration generates 20–30 % fine sinter and lump (< 3.15 mm) (Chapter III, Table 7.1).

Pellets are not very prone to reduction disintegration, as pellets have about 30 % voidage in the structure, which can take care of local expansion. As they retain their round shape, they do not impede the local permeability for gas.

Some lump ores have a very tight structure and are difficult to reduce, with the reduction starting on the outside of the particle. These lump ores will have reasonable RDI values. However, if a lump ore has a relatively open structure, which is easily permeable for gas, then the RDI will be poor. Lump ores with this characteristic are less suitable for direct use in the blast furnace for more than a few percent.

Sinter, on a micro–scale has a relatively tight structure with limited possibilities for local expansion. This means that sinter has inherently poor RDI unless measures are taken to improve it. The RDI can be improved by impeding the formation of the secondary hematite on the sinter strand. Secondary hematite is the material that is re–oxidized on the sinter strand, from magnetite back to hematite. This takes place when sinter is cooled with air. It is the secondary hematite that is very prone to reduction disintegration in the blast furnace. The reduction disintegration stops when all the hematite is reduced to magnetite.

8.1.2 Gas reduction of magnetite

The magnetite (Fe_3O_4) is further reduced by gas (CO and H_2) to wustite ($\text{FeO}_{1.05}$). At around 900 °C, equilibrium is reached between the reducing power of the gas and the composition of the iron oxides, i.e. the FeO level of one atom of oxygen per atom of iron. In this area the temperature is relatively constant

(thermal reserve zone), as is the chemical composition of the gas (chemical reserve zone). When blast furnaces are operated at very high productivities the reserve zone becomes smaller and is ultimately eliminated.

At temperatures around 900 °C the temperature of the coke is still too low to react with the CO₂ gas. The coke reactivity reaction ($\text{CO}_2 + \text{C} \rightarrow 2 \text{CO}$) starts at around 1000 °C. This means that all the reduction is taking place by means of gas reduction ($\text{Fe}_2\text{O}_3 + \text{CO} \rightarrow 2 \text{FeO} + \text{CO}_2$), and in this temperature range also for a small part by hydrogen reduction ($\text{Fe}_2\text{O}_3 + \text{H}_2 \rightarrow 2 \text{FeO} + \text{H}_2\text{O}$). The gas reduction continues to a gas temperature above 1000 °C and a reduction of iron oxide to a level of FeO_{0.5}. The higher the temperature, the more H₂ contributes to the gas reduction. The gas reduction continues, but coke starts to react with CO₂ and H₂O – which is chemically identical to the direct reduction reaction. If material starts to soften and melt (around 1200 °C) the direct reduction reaction ($\text{FeO} + \text{C} \rightarrow \text{Fe} + \text{CO}$) will take place. The direct reduction starts more or less at a ratio of O/Fe slightly below 0.5 atom O per atom of Fe. In the case of natural gas injection, this O/Fe for direct reduction can decrease to around 0.35 atom O per atom Fe.

8.2 Softening

Softening starts at local chemical compositions with the lowest softening temperatures. This is where there are high local concentrations of SiO₂ and FeO. Internal migration of atoms will cause larger and larger parts of the particles to soften. Softening starts as soon as internal ‘melts’ of material are formed. The softening temperature depends on burden type and composition. The details are in Section 10.9. In the book a softening temperature of 1200 °C is used. At this temperature, the O/Fe ratio in the ferrous burden is 0.35–0.5, which means that the FeO content in the “primary slag” is 60–70 %. The softened materials are called “primary slag”. Its composition is the gangue of the ferrous burden with large quantities of wustite (FeO); slag component from coke, coal and nut coke are not taken into account.

In the case of fluxed pellets, softening starts at approximately 1200 °C. Acid pellets soften at a temperature about 100 °C. Fluxed sinter starts to soften at temperatures above 1200 °C, which increases to 1300 °C for super-fluxed sinter. Lump ore softening depends on quality. It may start below 1000 °C and can reach considerably higher softening temperatures. It is very acceptable for high performance, especially dictated by the amount of acid slag components present.

As soon as the gangue starts to melt, it will come into contact with the slag components of other parts of the ore burden and the slag composition will be averaged. This happens at high FeO concentrations. Figure 8.1 on the next page shows the liquidus temperatures of “primary slag” as dependent on B₂ and FeO content. Slag melting starts at low temperatures and high FeO levels, but the

basicity of the burden affects melting. As the FeO is reduced out of the primary melt, the slag liquidus temperature increases. The primary slag of the reference furnace has a basicity when melting of 1.29, which is the gangue of all ferrous components plus the coke ash of the coke consumed by direct reduction. The figure shows that the liquidus temperature depends very much on slag FeO percentage as well as basicity. The primary slag liquidus temperature increases by around 50 °C for every 0.1 basicity increase.

In this respect it is important to understand, that the ash percentage of injection coals plays an important role, since coal ash contains approximately 50 % SiO₂. With high ash coals there is a need for a higher primary basicity. One of the advantages of using natural gas as an injectant is the lower primary slag basicity.

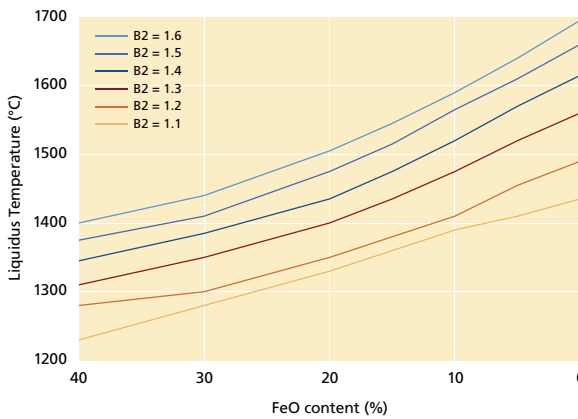

Figure 8.1 Slag liquidus temperatures of bosh slag and the effects of FeO content and basicity. The dark red line (B2 = 1.3) is the reference furnace. “MT data” software was used for calculations.

Softening is the process of collapse of the burden and depends on local chemical composition and the reduction progress. So, in order to keep the variation within the layers as small as possible, good blending of components is recommended. It is shown elsewhere (see Section 3.8) that blending improves metallurgical and softening and melting properties. Also, the use of nut coke in a burden layer results in better permeability, since nut coke does not soften with the burden and maintains a path for gas through the burden layer. Charging scrap or DRI in the ferrous burden also maintains the permeability of softened material up to higher temperatures.

In summary, softening starts in material with acid slag components mixed with iron oxides, which start to form melts, which in turn cause the ore bed collapse. The order of events is: First, the lump ore structure collapses due to the acidic gangue. Next the acid pellet structure collapses. This is followed by the collapse of the fluxed pellet and sinter structure. As soon as the layers have collapsed, the permeability for the gas decreases. It is estimated that permeability for gas

disappears more or less completely between 1200 and 1350 °C. In this situation, the layers of cohesive material are heated only by gas flowing along its surface. Reduction by hydrogen plays a special role in this situation. Since hydrogen can easily diffuse into a more compact structure, the hydrogen reduction continues after CO reduction has stopped.

8.3 Melting

Material is completely molten if the temperature is higher than the melting or liquidus temperature. Below that temperature solids are present, and it has a high viscosity and does not flow properly.

In a blast furnace we have the hot metal and slag components. The liquidus temperature depends on chemical composition especially on the FeO content and basicity.

In Figure 8.2, the melting temperatures of hot metal is given. Comparison with slag liquidus temperatures of Figure 8.1 shows that primary slag with a high FeO content melts at a lower temperature than hot metal with low carbon. That is the reason that primary slag melts in the first instance at temperatures of 1300 °C. Reduced iron does not contain carbon, which is dissolved as soon as FeO content in the direct environment is low (below 10 %).

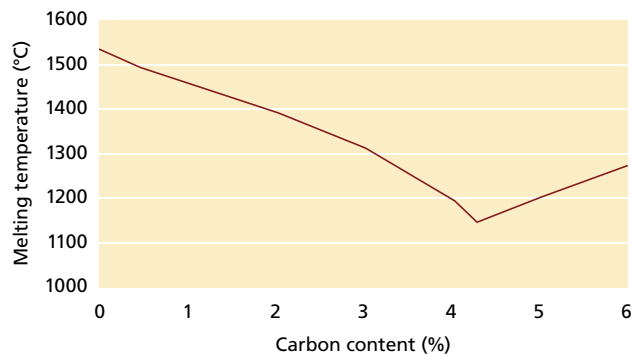

Figure 8.2 Melting temperatures of iron

For this reason, reduced iron, for example a sponge iron skull of a pellet, has a much higher melting temperature than hot metal. The sponge iron does not yet contain carbon, and its melting temperature comes closer to the 1535 °C of the elemental iron rather than the 1147 °C of hot metal with a 4.2 % carbon content. The reduced iron does not melt, but remains as solid particles in the melting slag–FeO mix.

When softened materials are heated further and start to drip, the “primary melt” consists of a blend of the gangue, FeO and finely dispersed iron, which has not been separated from the melt. The first process in the ‘primary’ melt

is that the gangue loses its FeO. The reduction of FeO is by direct reduction, which requires heat that has to be supplied by the bosh gas. So, the contact between bosh gas and primary melt determines the rate of melting. 80–90% of the heat present in the bosh gas at a temperature above 1400 °C is required to drive the direct reduction reaction. The direct reduction consumes coke. This makes the acid coke ash available, which lowers gradually the basicity of the primary slag.

As soon as the FeO is removed and the primary melt flows over the coke, the iron starts to dissolve carbon from the coke, which rapidly lowers the melting temperature of the iron. This has the effect of making the iron much more liquid when flowing over the coke. The carbon of the coke diffuses into or is taken up by the metallic Fe, allowing the iron droplets to separate from the primary melt. After this process has taken place, the iron starts to increase in silicon content, which comes from the SiO gas that was created in the raceway flame.

As long as the slag contains FeO, the silicon in the hot metal will be oxidized back to SiO₂ and the FeO in the slag reduced to Fe. At the wall of the furnace, the root of the cohesive zone is located a small distance above the tuyeres, while in the center the cohesive zone is located higher in the furnace. As a consequence, the slag formed at the wall will have relatively high FeO and the hot metal formed at the wall will have low silicon. While the hot metal formed and dripping down in the center of the furnace will have high silicon. The final silicon level observed during a cast is a blend of these two ‘hot’ and ‘cold’ components.

The formation of the final composition of hot metal and slag is a stepwise process, which is summarized in Figure 8.3.

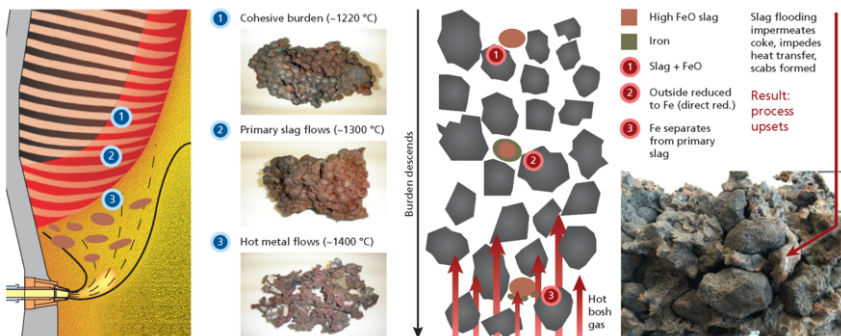

Figure 8.3 Melting of Iron Ore

Liquid hot metal and slag drain down through the coke. The available voidage of the cokes has to hold the slag and may be the rate limiting factor for the production level. Figure 8.4 shows a comparison between several furnaces regarding the amount of liquids that are processed per m² of hearth surface.

Very few furnaces exceed a liquid hot metal and slag production level of about $22 \text{ m}^3 \text{ liquids/m}^2 \text{ hearth.24 hrs}$. The limitations are influenced not only by the amount of liquids, but also by the area for the liquids to flow through (furnace dimensions as well as coke voidage) and the amount of gas that ascends through the dripping liquids and coke voidage. The available coke voidage comes from the coarse coke only and is determined by coke quality as well as the amount of coke present per tonne of hot metal. The latter decreases with increasing PCI rate. If the slag volume per tonne of hot metal increases, the required voidage is larger and as a consequence the PCI rate or productivity has to decrease.

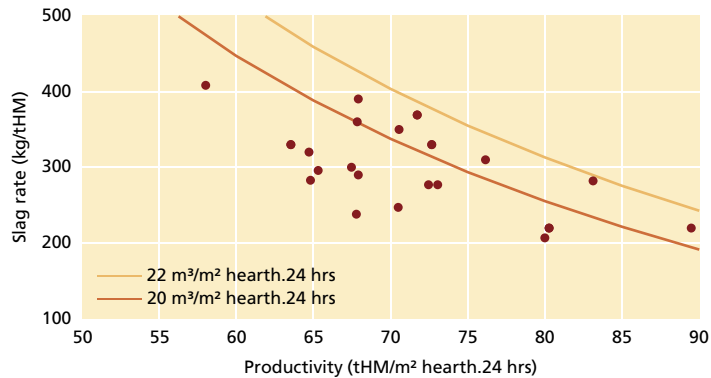

Figure 8.4 Liquid (sum of hot metal and slag volume) and production levels of operating furnaces with a hearth diameter over 10 m are indicative of limiting flooding conditions

8.4 Formation of hot metal and slag as cast

8.4.1 Radial asymmetry of hot metal and slag

The hot metal and slag as dripping down from the cohesive zone have been formed from local conditions. In the center of the furnace hot metal with high silicon is formed, at the wall low silicon. The elimination of FeO from the primary slag is faster in the center than at wall. In the raceway coke and coal are gasified generating acid coal and coke ash, which condenses on coke close to the tuyeres. Part of the SiO_2 in the coal and coke ash is reduced to generate silicon monoxide gas, that is then further reduced to form atomic silicon which dissolves in the hot metal. Basicity is high in the center and lower in the wall area, because there is more SiO_2 available in the wall area. The final hot metal and slag compositions are formed in the taphole by blending liquids from the different regions of the hearth.

8.4.2 Hot metal–slag interactions

The final hot metal and slag compositions are the result of a complex process of iron–slag interactions as the various elements are divided over the slag and iron phases. The dispersion of an element over the two phases depends on the slag and hot metal composition as well as temperature, as discussed below. As an illustration the typical percentages of elements entering the slag and iron phases are indicated in Table 8.1.

The following points should be noted:

- Silicon, titanium and sulfur are concentrated in the slag.
- Manganese is concentrated in the hot metal.
- Most alkali (potassium and sodium) are eliminated with the slag, some of the alkali is discharged as vapor with the top gas.
- Nearly all the phosphorus goes to the hot metal.

Element	Input	Output to Iron		Output to Slag	
	kg/tHM	kg/tHM	%	kg/tHM	%
Silicon	46	5	11	41	89
Manganese	6	3.6	80	2.4	20
Titanium	3	0.7	23	2.3	77
Sulfur	3	0.3	10	2.7	90
Phosphorus	0.7	0.7	98	0	0
Potassium	0.15	0	0	0.11	73

Table 8.1 Typical distributions of selected elements over iron and slag

Hot metal temperature and hot metal silicon content are both used as an indicator of the thermal state of the furnace. The hot metal temperature is the result of the heat input in the furnace minus the heat used in the lower part of the furnace. The major heat consumption in this area comes from the (endothermic) chemical reactions taking place below the cohesive zone. These are the direct reduction reactions of iron, silicon, manganese, titanium and phosphorus oxides. While the hot metal silicon shows the result of the actual chemical balance in the furnace, the hot metal temperature is somewhat delayed compared to the hot metal silicon, since there is a large heat buffer in the hearth.

Silicon, manganese, titanium and phosphorus oxides are reduced via the direct reduction reaction. These reactions consume much heat. Most of the heat is consumed for the SiO_2 reduction and consequently, the hot metal silicon content reflects the thermal state of the furnace. The manganese distribution over hot metal and slag, $[\text{Mn}]/(\text{MnO})$, is an even faster indicator of the thermal state because of the smaller MnO content of slag. For operational purposes, the silicon reactions are of particular interest. The hot metal silicon is a sensitive indicator of the thermal state of the furnace, and the silicon variation can be used to analyze the consistency of the process.

8.4.3 Hot metal silicon

The reaction of silicon reduction in a blast furnace are now discussed in more detail. Reduction of silicon from silica by carbon is possible at a temperature above 1400 °C:



Silicon transition into hot metal is promoted by reaction of iron silicide formation:

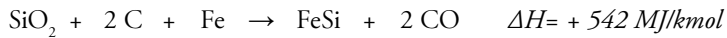

Silica reaches the high temperatures required for these reactions when coke and coal are burned. Coal and coke ash contain typically 45–50 % SiO_2 . SiO_2 is also part of the melting burden materials which contain gangue. Silicon reduction in blast furnace takes place via two stages (Figure 8.5).

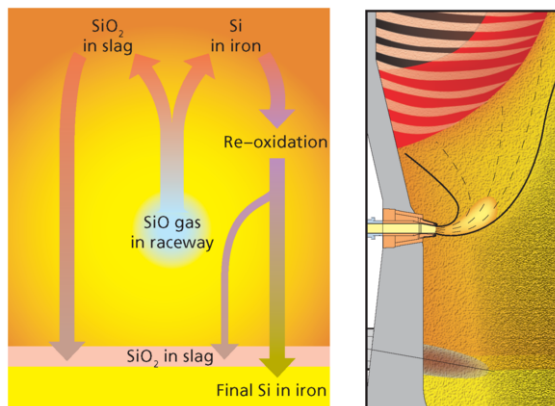
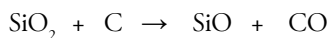

Figure 8.5 Silicon reduction

At stage 1 in the combustion zone, volatile silicon monoxide gas is formed from the silica of the coke ash and injected pulverized coal ash.



SiO formation in raceway zone increases:

- when ash content in coke and PCI increases, and/or SiO_2 content in the ash increases,
- when the flame temperature (RAFT) increases,
- when the residence time of coke in the high-temperature zone increases, which means that smelting rate and the furnace production output are decreasing.
- silica reduction is accompanied by generation of CO gas. So, an increase in the pressure in the furnace impedes silica reduction and its formation to SiO gas.

At stage 2, the silicon is reduced from SiO by coke in the area of the raceway and cohesive zone. It is dissolved in hot metal droplets. The following reactions take place:

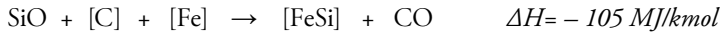
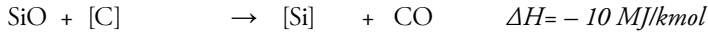

Research has shown that reduction of silicon takes place in the high-temperature area above the raceway. When hot metal is sampled through the tuyeres the hot metal has a higher silicon content than when sampled from the cast. The higher the level of the cohesive zone, the larger the volume of the high-temperature zone and the more time there is for contact of volatile SiO with carbon of coke and hot metal. This leads to an increase in silicon reduction and consequently higher hot metal silicon content and higher hot metal temperature.

The contact time of hot metal with gas and coke in the coke layer between tuyere level and cohesive zone is dependent on the structure of the coke bed and the size of coke as well. The more coke fines, the smaller the fraction of middle-size lumps of coke and the better the adhesive behavior for molten slag, and the more the porosity of the coke layer decreases. This increases the time for the hot metal and slag to descend through it, and there is thus more intensive contact between the (SiO-containing) gas, which results in additional Si reduction. As discussed above, silicon is partially reduced by coke carbon from slag. Silicon reduction from slag is impeded by an increase in basicity, which decreases the rate of Si reduction from calcium silicates.

In summary: the Si content in hot metal can be decreased by the following measures:

- lowering the cohesive zone inside the furnace, which means running the furnace at a lower thermal level.
- using a lower flame temperature.
- increase of coke CSR and average size of coke lumps charged into furnace.
- reduction of ash content in coke and injection coal.
- increase of top gas pressure.
- increase of the percentage of CaO and MgO in slag.
- increase of oxidation potential in the hearth (see below).
- increase of the production levels (melting rate) with increasing blast volume.

One aspect not yet mentioned is that in the hearth hot metal comes into contact with slag and remains in equilibrium with it. When hot metal droplets pass through the slag layer in the hearth, Si may be re-oxidized by ferrous oxide, if it is present in slag:

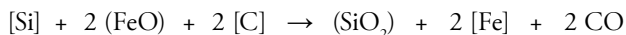

Example 8.1 Properties of high silicon hot metal

During blow-in of a blast furnace or during a chill recovery a high coke rate and low basicity burden are often used. This can lead to high hot metal silicon levels, for instance 4 % or more. This type of hot metal can be very viscous and can generate scabs in the runner system. When the hot metal cools down graphite can be generated in the hot metal flow. The reason for the high viscosity is that solid particles can form in the hot metal.

A relatively new insight is that this phenomenon of poorly flowing hot metal takes place not only in the runner system, but can also be observed when a blast furnace is operated for a prolonged period on very high coke rates and high silicon. The phenomenon is illustrated in Figure 8.6, where the measured hot metal silicon and carbon during a furnace recovery are shown in a silicon–carbon phase diagram, where it is assumed that hot metal can be oversaturated with carbon. SiC can form at a silicon content above 4 % and $\text{Fe}_8\text{Si}_2\text{C}$ at temperatures below 1300 °C. During a recovery it is important to go towards silicon levels below 2 % fast. If such segregation takes place below the tuyeres, unexplained tuyere failures (on bottom) can be observed, because hot metal does not drain to the hearth.

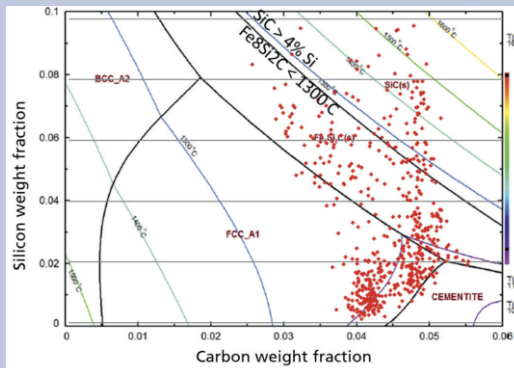

Figure 8.6 Fe–Si–C phase diagram of hot metal oversaturated with C (Mn = 1 %). Hot metal composition during a chill recovery indicated with red dots.

FeO is observed in slag when the furnace is very cold. Slag is very heavy and granulated slag is black. In these situations, the furnace has a very low silicon level. From a chemical point of view this is called increase of oxidation potential in the hearth. This mechanism also explains why the hot metal sampled at the tuyeres has a higher silicon% than hot metal coming from the taphole.

Finally, although we observe a uniform hot metal silicon level coming from a taphole, in reality the hot metal is a blend of hot metal generated in the central part of the furnace with a higher Si content and hot metal generated in the peripheral zone with a low hot metal Si content.

Hot metal silicon varies from cast to cast and during a cast as well. Changes in energy input and output become manifest in the hot metal silicon. Very stable hot metal silicon is the result of stable operating conditions, the most important being stable burden descent. If the burden descent is not smooth, the gas reduction in the furnace varies, resulting in variation in direct reduction in the high temperature area below the cohesive zone. In this situation the re-oxidation of silicon will vary more.

For operators it is well known that the hot metal silicon increases when the blast volume is decreased. From the previous section it is clear that when wind is reduced the following effects will take place: lower driving rate of the furnace allowing the hot metal more time for contact with (SiO₂-containing) gas, improved gas reduction by better contact between burden and gas, sometimes improved burden descent and finally a lower top pressure. All these effects result in higher hot metal silicon at lower blast volume.

8.4.4 Hot metal Sulfur

The major sources of sulfur input are the reductants, i.e. coke and PCI, which introduce 80–90 % of sulfur to the furnace, while only 10–20 % comes with the burden materials. Most sulfur in the fuel (60–80 %) is organic, whereas the sulfur in burden materials is present in the form of sulfides and sulfates. Sulfur input into the furnace for modern blast furnaces is 2.5–3.5 kg/tHM.

As soon as the coke temperature exceeds 1000 °C, part of the sulfur volatilizes. During combustion of coke and injected fuel, all sulfur is oxidized in the form of gaseous SO₂ and SO. In the more reducing atmosphere, sulfur oxides react to free sulfur (S, S₂) and its compounds CS, CS₂, COS, H₂S, HS. Sulfur reacts when ascending through the furnace with burden components, forming calcium, iron and manganese sulfides. These sulfides descend to the hearth again. Calcium, magnesium and manganese sulfides dissolve in slag, while iron sulfide dissolves in hot metal.

More than half of the input sulfur is transferred to slag by the following reaction:

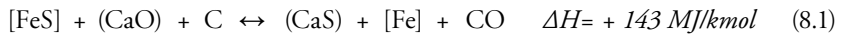

Where () means concentration in slag and [] in hot metal

The distribution of sulfur between slag and hot metal (L_s) is estimated as relation $L_s = (S)/[S]$ and depends on the slag basicity and on the temperature of hot metal and slag. Sulfur quantity transiting to slag also depends on the slag volume per tonne. The sulfur content in gas, solid and liquid phases over the height of the furnace are shown in Figure 8.7.

The sulfur brought into the furnace with fuel, is first brought to the gas phase before being eliminated from the furnace. As a result at each moment a significant quantity of sulfur is retained in the blast furnace, estimated as 4–8 tonnes sulfur for 3000–5000 m³ furnaces (at a coke sulfur content of 0.6 %).

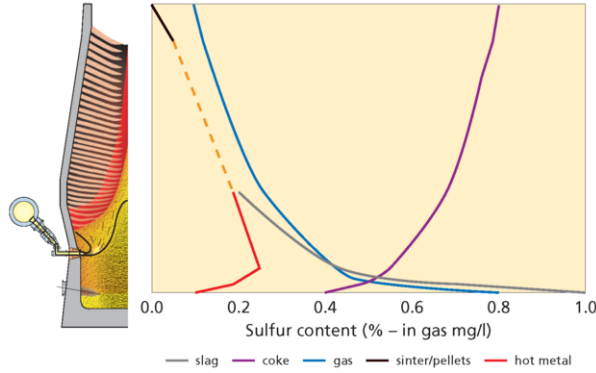

Figure 8.7 Sulfur content of gas, solid and liquid phases over the blast furnace height

Desulfurization of hot metal takes also place in the taphole when hot metal and slag are cast simultaneously. In the taphole, pressure decreases from a high value inside (around 5 bar) to atmospheric pressure outside the blast furnace, which makes the equilibrium (8.1) shift to the right, to lower hot metal sulfur. This is illustrated by an example of the hot metal sulfur in consecutive ladles, showing about 20 % lower levels as a consequence of slag and hot metal being cast simultaneously (Figure 8.8).

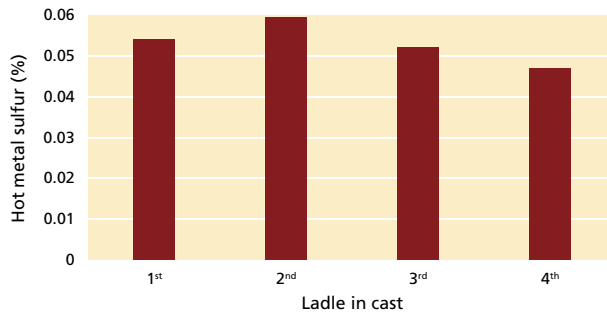

Figure 8.8 Sulfur content in consecutive ladles of a cast from a 2600 m³ IV furnace

Example 8.2 Silicon, sulfur and basicity correlations in operation

Hot metal silicon and temperature are correlated as indicators of the thermal state of the hearth. In the graphs below, these correlations are illustrated for an operating blast furnace with 10 months of cast by cast data. The data are “cleaned”: gap times shorter than 30 minutes, HMT 1450–1530 °C.

Trend comparisons can be made by making correlations over long periods or by considering relative changes, for example the change in hot metal silicon corresponding with a change in hot metal temperature of the preceding casts. Correlation of hot metal temperature and silicon is shown in Figure 8.9. Hot metal sulfur decreases with increasing silicon as shown in Figure 8.10.

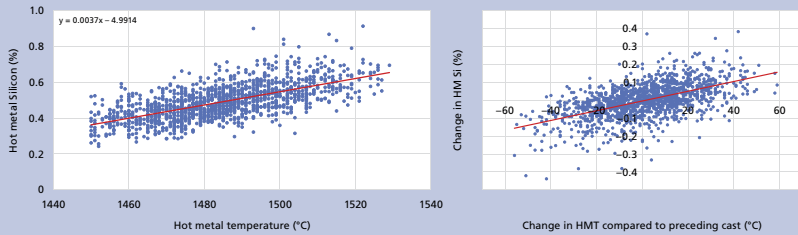

Figure 8.9 Correlation of hot metal silicon and temperature. The right hand graph shows the difference in hot metal silicon and temperature compared to the preceding cast.

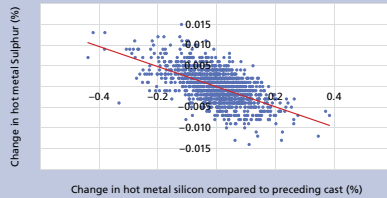

Figure 8.10 Change in hot metal S and Si

For sulfur the operator can consider the ratio (S)/[S], the sulfur in slag divided by the sulfur in hot metal. This ratio is independent of slag volume. Correlations with 2– and 3–component basicities shown in Figure 8.11.

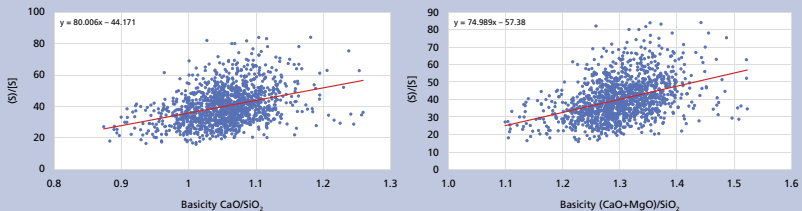

Figure 8.11 (S)/[S] correlation with basicity B2 (left) and B3 (right).

8.5 Slag properties

8.5.1 Slag composition and basicity

Slag is formed from the gangue material of the burden and the ash of the coke and auxiliary reductants. During the process primary slag develops to a final slag. Four major components make up about 96 % of the slag, these being SiO_2 , MgO , CaO and Al_2O_3 . The balance is made up of components such as manganese (MnO), sulfur (S), titanium (TiO_2), potassium (K_2O), sodium (Na_2O) and phosphorus (P). These components have a tendency to lower the liquidus temperature of the slag. The definitions of basicity are given in Table 8.2 and typical compositions of hot metal and slag in Table 8.3.

B2	CaO/SiO_2
B3	$(\text{CaO}+\text{MgO})/\text{SiO}_2$
B4	$(\text{CaO}+\text{MgO})/(\text{SiO}_2+\text{Al}_2\text{O}_3)$

Table 8.2 Definitions of basicity (weight percentage)

Hot metal		Typical	Slag	Typical	Range
Iron	Fe	94.5 %	CaO	40 %	34–42 %
Carbon	C	4.5 %	MgO	10 %	6–12 %
Silicon	Si	0.40 %	SiO_2	36 %	28–38 %
			Al_2O_3	10 %	8–20 %
Manganese	Mn	0.30 %			
Sulfur	S	0.03 %	Sum	96 %	
Phosphorus	P	0.07 %	Sulfur	1 %	

Table 8.3 Typical hot metal and slag compositions

8.5.2 Slag properties

The final slag has a higher melting temperature than hot metal. In practice it is more correct to think in temperature ranges than in melting points, as composite slags have a melting trajectory rather than a melting point. The liquidus temperature is the temperature at which the slag is completely molten. At temperatures below the liquidus temperature solid crystals are present. These solid crystals increase the viscosity of the slag. In our experience the behavior of slag can be well understood on the basis of its liquidus temperature, except for high Al_2O_3 percentages. Figure 8.12 on the next page shows the viscosity of slags. Acceptable flow rates are at a viscosity below 5 poise. It is clear from the figure that these values are exceeded at 20 % Al_2O_3 .

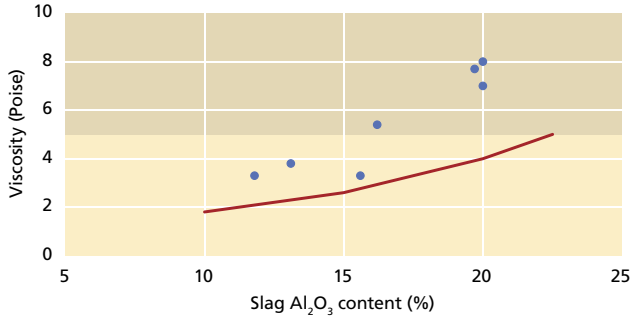

Figure 8.12 Effect of Al_2O_3 on slag viscosity at 1500 °C, in poise (10–1Pa.s). Acceptable flow is effected below 5 Poise. Dots are calculated for operating blast furnaces, the line is based on Slag Atlas (1995) with a B2 basicity of 1.05 and an MgO level of 10 %.

Liquidus temperatures are presented in ternary diagrams such as Figure 8.13. These diagrams have been developed for pure components and in practice the liquidus temperatures are somewhat lower.

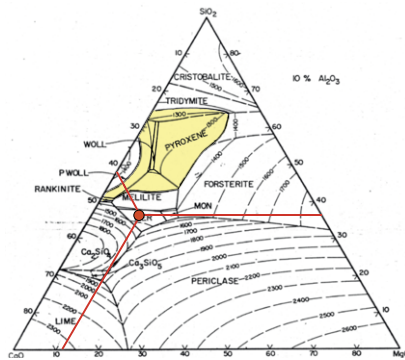

Figure 8.13 Phase diagram of liquidus temperatures of blast furnace slag for 10 % Al_2O_3 . The red dot indicates a slag composition of 40 % CaO, 10 % MgO and 36 % SiO_2 . To this end, these main components have to be recalculated from 96 to 100 % of the slag. The area where the liquidus temperature of the slag is lower than 1350 °C is indicated in yellow. (After Slag Atlas, 1981)

Since in the ternary diagrams only three components can be indicated, one of the major slag components is taken as fixed. i.e. Al_2O_3 content is 10 %. Diagrams at different Al_2O_3 percentages are presented in Figure 8.14. The typical slag composition for a blast furnace slag is also indicated (Table 8.3). Note that the liquidus temperature (red dot) is about 1400 °C and that the liquidus temperature increases when CaO increases (i.e. when the basicity increases). However, the viscosity decreases as CaO and MgO increase because these basic oxides break up the more strongly bonded network formed by the acidic oxides SiO_2 and Al_2O_3 .

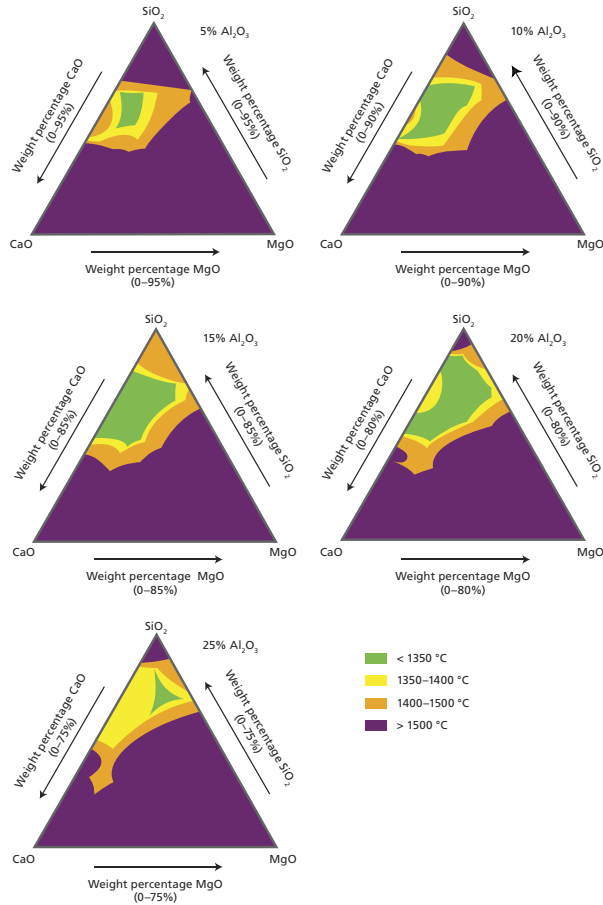

Figure 8.14 Phase diagrams of slag liquidus temperatures at various Al_2O_3 levels. Areas where liquidus temperature is lower than 1350°C are yellow. (After Slag Atlas, 1981)

High Al_2O_3 slags

The Al_2O_3 content of the final slag varies according to the raw materials in use. Especially in India, the raw materials are rich in Al_2O_3 . Operational practice shows that it is possible to run a blast furnace with around 18% Al_2O_3 . However further increase of the Al_2O_3 content to 20–22% is done by some companies, but even higher content is (almost) impossible.

In Figure 8.15, the composition of the slag resulting from a burden of self-fluxed sinter and pellets is indicated with a red dot. The liquidus temperatures of the “pure” components show high liquidus temperatures for the slag, well above 1500°C . How is it possible that the material melts in the cohesive zone? The secret behind the melting of sinter and pellets is that the ore burden contains a high FeO percentage, which lowers the melting temperature or, as mentioned earlier, lowers the liquidus temperature and solidus temperature.

This is shown in Figures 8.15 and 8.16.

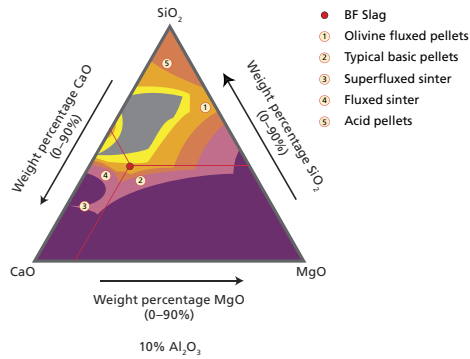

Figure 8.15 The slag composition of typical pellets and sinter qualities

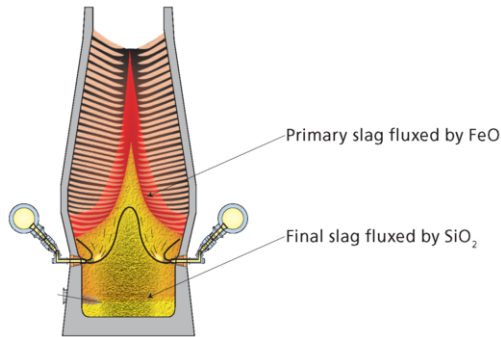

Figure 8.16 Slag formation

8.5.3 Hot metal and slag design for stops and starts

During special blast furnace situations, such as a blow-in or a very hot furnace, the hot metal silicon can rise to very high values. Since the silicon in the hot metal is taken from the SiO_2 in the slag, the consequence is that the basicity increases. This leads to high slag liquidus temperatures (Figure 8.17).

In a situation with very high basicity, the final slag does not remain liquid in the furnace and cannot be cast. It will accumulate in the furnace, where it can form a ring of solid slag, particularly in the bosh region. Burden descent and casting will be disrupted. For this reason, for special situations where hot metal silicon is expected to be high, the slag should be designed to handle the high hot metal silicon. A reduced slag basicity is required. To this end, extra SiO_2 has to be brought into the furnace, and the recommended method is the use of siliceous lump ore.

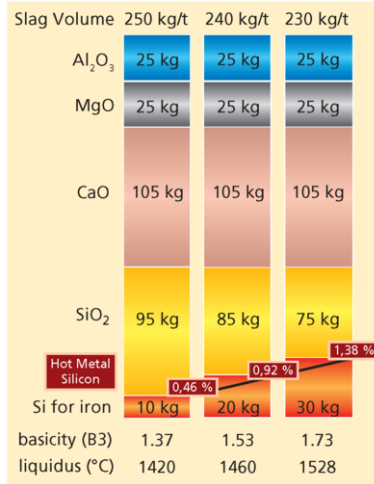

Figure 8.17 Slag properties at increasing hot metal silicon, a typical example

Some companies use quartzite, which is suitable for correcting the basicity in normal operation. However, it is less suitable for chilled situations, since the liquidus temperature of quartzite itself is very high (1700 °C). The effect of the use of a siliceous ore is shown in the ternary diagram in Figure 8.18: by working at a lower basicity, the liquidus temperature decreases along the line indicated.

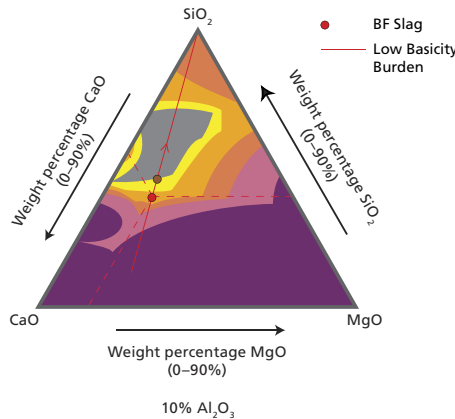

Figure 8.18 Effect of low basicity burden on slag liquidus temperatures. The red dot represents a normal slag composition, the brown dot a 20 % lower B2 basicity.

This page intentionally left blank

IX Casting Hot Metal and Slag

9.1 Introduction

The blast furnace process produces liquid hot metal and slag. The two liquids drip down into the coke-filled hearth of the blast furnace, where they wait to be tapped, or cast, from the furnace. Liquid hot metal and slag do not mix well and separate. The densities of the two liquids are quite different; with hot metal (7.2 t/m^3) being three times that of slag (2.3 t/m^3). The hot metal and the slag separate inside the hearth before the liquids are tapped, as well as outside in the runner system, with slag floating on hot metal. The present chapter is about the question of how hot metal and slag are cast from the furnace.

A cast has a typical duration of 60–240 minutes. It starts with drilling a hole (diameter 40–70 mm, length 2,5–4,5 meter). During a cast, hot metal and slag flow within the hearth towards the taphole. Hot metal has a very low viscosity and flows easily, but slag has higher viscosity and flows with greater difficulty. At the end of a cast, the “dry” condition is indicated by a blowing taphole: gas escaping with liquids causing spraying at the taphole face. At that point, the cast has to be plugged. Note that at the end of a cast, the liquid hot metal surface in the hearth is quite horizontal, but the slag level slopes downwards to the casting taphole. As a consequence, a large amount of slag remains in the furnace at the end of a cast, shown in Figure 9.1.

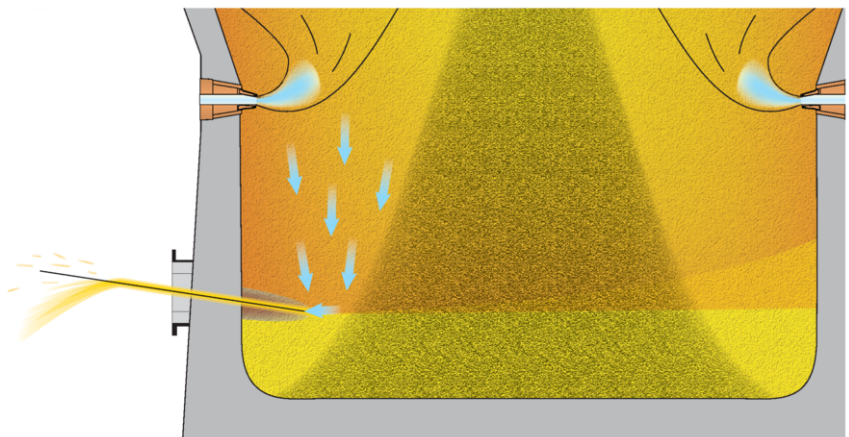

Figure 9.1 “Dry” taphole showing ingress of gas and the slope of the slag surface

After that a cast is plugged, and another cast has to be opened. Most large furnaces have continuous casting, which means that another taphole is opened just before or as soon the cast has been plugged. The time between the end of a cast on one taphole and opening the next is called gap time. To a large extent, the gap time determines the highest liquid level in the furnace during next cast! The majority of modern high productivity blast furnaces have been between 2 and 5 tapholes. During In normal operation of a furnace with two or more tapholes, the tapholes will be used alternately, with one cast being on one taphole, and the next cast being on the other. This also applies to furnaces with up to five tapholes. The reason for having at least three tapholes is to ensure that there are always two or more in operation, even during times of casthouse repair, or emergency breakdown. This allows the production level to be maintained, since two or more tapholes can drain the hearth.

Single taphole furnaces do exist, most of them being smaller size furnaces that show different behavior and requirements for casting. Single taphole operation is described in Section 9.6.

The objective of casthouse operation is to prevent interference in the liquid level inside the furnace. To this end the liquid level has to be kept as low as possible. Continuous or alternate casting is the basis for the description in this chapter.

- How liquid level interferes with the process
- Casting regimes
- Flow of hot metal and slag through the taphole
- Taphole operation: drilling, plugging, clay quality
- Casthouse operational challenges.

9.2 Liquid level and the blast furnace process

Why is the blast furnace operator concerned about the liquid level in the hearth? How much time does he have to take decisions? About the latter question: how long does it take after a dry cast before the liquid level reaches the level of the tuyeres? Because, as soon as slag is at tuyere level, the furnace can no longer be stopped without filling all tuyeres with slag. In Example 9.1, it is calculated to be 79 minutes, so timely actions are required in case of delays.

How does liquid level affect the blast furnace process?

Experienced operators will tell you that with poor casting, so increasing liquid level:

- The blast pressure may increase,
- The burden descent may slow down,
- Blast pressure increases and heat losses (or stove temperatures) increase.

The operator will also tell of burning tuyeres, tuyere stocks that fill with slag on occasion, and of blowpipes that “burn out of the furnace”. The latter two are incidents with major damage.

Example 9.1 How long does it take to fill hearth with liquids from taphole to tuyeres?

The time available to fill the area between the taphole and tuyeres can be estimated by taking the volume of the produced liquids into account and the voidage of coke, here taken as 20 %. According to Example 9.1: for the reference furnace it takes 79 minutes to fill the voidage between taphole and tuyeres with fresh liquids from the production process. The voidage is not uniform through the hearth, there is low voidage in the deadman and close to the bottom, while there is high voidage expected in a ring around the hearth.

Distance taphole–tuyeres	m	4.6
Diameter	m	15
Volume tuyeres–taphole	m ³	812
Voidage	%	20
Volume available	m ³	162
Hot metal production	tHM/d	12000
	m ³ /hr	69
Slag rate	kg/tHM	250
	m ³ /hr	54
Liquids production	m ³ /hr	124
Time to fill	min	79

Table 9.1 Time to fill the reference furnace at full production from “dry” to liquids at the tuyeres

Burden descent

The liquid level in a blast furnace affects burden descent. Figure 9.2 shows an operational example of burden descent and casting for single taphole operation.

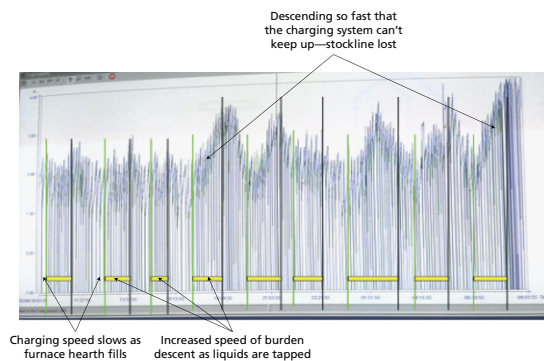

Figure 9.2 High residual liquid levels and burden descent in a single taphole furnace (1400 m³ IV)

There is a large gap time, and so in between casts, the liquid level rises and burden descent slows. When the taphole is casting, burden descent speeds up significantly, especially when there is a large flow of liquids towards the end of cast. This may occur to the extent that the charging system is unable to keep up and a lowered stockline is the result. The example is extreme, but similar effects can occur in alternatingly casting furnaces. Generally, with increasing liquid level, burden descent slows and blast pressure increases, even when the liquid level is still far below the tuyeres. How is this possible?

A major effect of a high liquid level is that it influences burden descent and blast pressure by changing the flow of coke towards the tuyeres. For the reference furnace, about 10–20 lumps of coke are drawn into the raceway per second. The cokes moves over the tuyere body and nose as indicated in Figure 9.3a, because of the low pressure at the nozzle caused by the high wind velocity. Tuyeres work like an ejector, with low pressure and coke ingress being found around the tuyere nose circumference. It was found experimentally that coke even 2 meters below the tuyere is drawn to this “tuyere injector”.

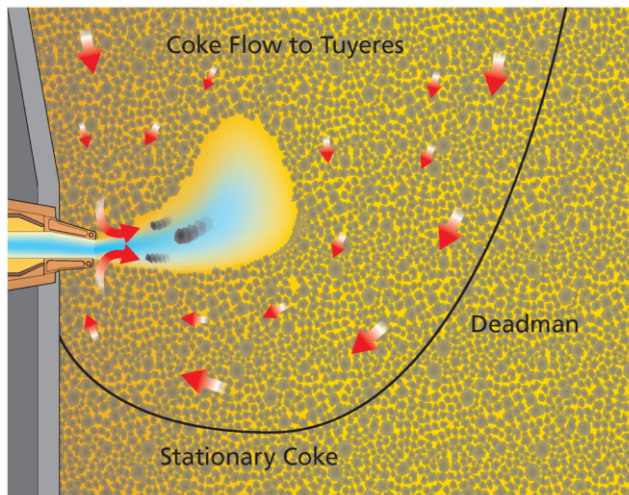

Figure 9.3a Coke flow towards the raceway during normal operation

- Tuyeres work like ejectors
- Local low pressure at the nose draws coke into the raceway, all around tuyere nose
- Below the raceway there is a border between “stationary and moving” coke (dotted line), the border of the deadman
- Coke is supplied from the active coke zone (arrow)

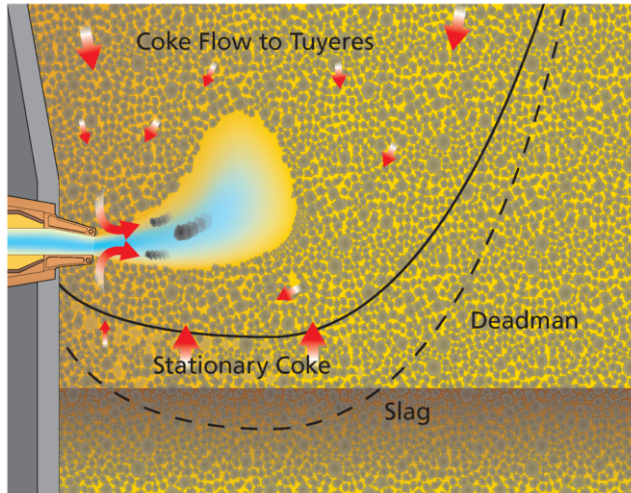

Figure 9.3b *Coke movement with increasing slag level*

- The stationary coke comes in the moving coke zone and starts to flow towards the tuyere
- Coke flow from the active coke zone is impeded. Slower burden descent
- More voidage in hearth (coke is not replenished)

Figure 9.3b explains how this mechanism changes when hearth liquid levels are higher. Coke submerged in hot metal and slag tries to float and thus exerts an upward force, which increases as the liquid level rises and decreases with falling liquid level (Section 7.2). The upward force of the submerged coke presses from below through the coke grid on the cohesive zone, which is compressed from above by the weight of the charge. Softening materials, in particular, are compressed, and the voidage in the cohesive zone decreases. This makes the burden less permeable, so hot blast pressure will increase. It is important to note that the tuyeres opposite the operating taphole are the first to be affected because the slag level is highest opposite the casting taphole, so that the mechanism leads to asymmetry.

If the slag level reaches the tuyeres, the situation becomes quite severe: dispersed slag droplets will start to be blown into the active coke zone, gas flow will bend towards the wall, and heat losses in bosh and belly will increase. If the furnace has to be stopped, all the tuyeres fill with slag. Although this is poor operation, furnaces frequently overcome the problems if appropriate liquids are cast in time.

If the liquid level continues to increase, so that hot metal rises to the tuyere level, hot metal will flow into the tuyeres and blowpipes and cause a catastrophic failure. This will lead to a blow-out of coke and slag and cause a critical emergency stop, with all tuyeres filled with slag, sometimes into the bustle main. Blast furnaces cannot overcome the problem of hot metal at tuyere level without major failures.

In summary and in other words: high liquid levels affect blast pressure, burden descent and heat losses, as is shown schematically in Figure 9.4. High liquid level affects the coke movement into the raceway burden descent, as well as cohesive zone shape and permeability. The bosh gas is deflected more towards the wall, rather than through the center of the furnace. In this instance the bosh is subject to much higher heat loads than normal, and the root of the cohesive zone will move downwards. However, at the same time, the cohesive zone will drop at the center of the furnace, due to the reduction in gas passing through the center. The blast pressure will also be higher as the resistance in front of the tuyeres is higher, and the burden descent will slow considerably.

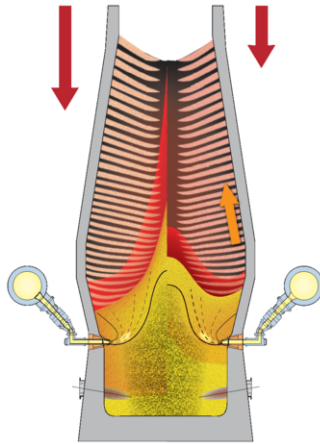

Figure 9.4 Consequences of increased liquid level (red arrows indicate burden descent rate, the arrow along the wall increasing heat losses)

For these reasons, the liquid level inside the furnace has to be kept as low as possible. Various casting regimes can be used for this.

“Dry” condition and measurements of liquid level

In the past, observation of a “blow” was the decisive indicator of a dry hearth. In reality, a blow shows that gas is escaping from the taphole. So, in situations with cracks in the mushroom or very large flows just before the blow, a very large amount of liquid can remain in the furnace, so the furnace is not “dry”. For this reason, various methods have more recently been developed to observe the liquid level in the hearth more directly. The most applicable methods are:

1. Measurement of EMF (electro motive force) in the furnace: the signal is sensitive to the amount of liquid within the furnace (Figure 9.5). Operators tend to rely more and more on it, even though the measurement is affected by all electrical influences, like hot metal temperature. All these influences have to be eliminated for reliable measurements.
2. Calculating the balance of slag and hot metal from the production level and the slag and hot metal flow measured. Slag flow can be measured continuously, depending on type of granulation – from temperature increase of granulation

water, from power required to drive the rotational dewatering of the slag, or by a weighing system in the conveyor belt that carries the slag to storage. Hot metal flows can be measured directly with a weighing system in the rails, from the descending velocity of the springs of the ladles, or from the level in the ladles used for transportation of the hot metal. An example is shown below in Figure 9.10.

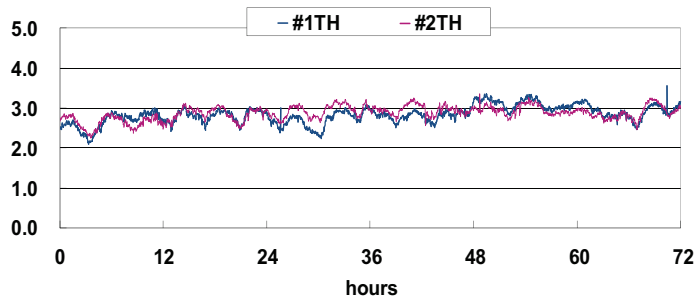

Figure 9.5 Signal of EMF showing the liquid level in the hearth
(Seong–Moon Kim and No–Kun Hur, 2011)

Direct measurements of slag and hot metal flow tend to be more accurate and more reproducible than indirect measurements, but they are not sufficiently reliable to indicate that the maximum level in the ladles has been reached for a timely reaction.

9.3 Monitoring casting regimes

During the cycle of starting a cast, plugging it and opening the next cast, the liquid level varies inside the furnace. The gap time between casts determines how high the level in the furnace will be. The duration of a cast depends not only on gap time, but also on drill diameter, taphole length and the quality of the clay, i.e. the resistance of clay to wear, especially from slag. Operational working methods also contribute to variations: is the taphole well plugged, is it drilled completely through, is there gas leakage in the taphole? All these influences make cast duration and the moment when slag is cast quite variable. For this reason, it is important to monitor casthouse operation.

This can be done with the help of a cast tracking chart in the control room to provide the operator with a quick overview of casting in the last shift or day. An example of a chart is shown in Figure 9.6 on the next page. On the basis of a chart like this, the actual situation can be reviewed immediately, and delays, drilling problems or other problems become clear. The charts are from a well operated furnace in March 2020.

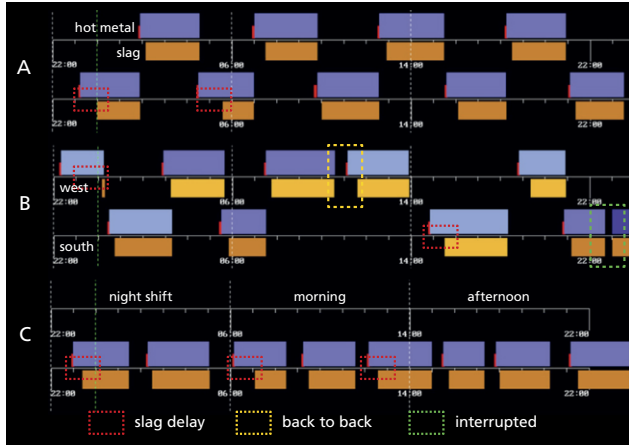

Figure 9.6 Cast tracking charts – 24 hour overview for three different days in March 2020 (2700 m³ IV blast furnace with two tapholes).

Issues like slag delays or back-to-back casting are immediately clear from a tracking chart like this. In this example:

- A. is a day of good casting,
- B. is a day with some problems,
- C. shows a day of single taphole operation with slag delays on nearly every cast.

The effects of casting parameters like gap time, drill diameter, taphole length and clay quality can be analyzed with a computerized model, which is described in Example 9.2.

For high productivity and high slag volumes, large modern furnaces sometimes operate three tapholes. An example is shown in Figure 9.7. The furnace is casting 41 hours per day with 96 % slag coverage.

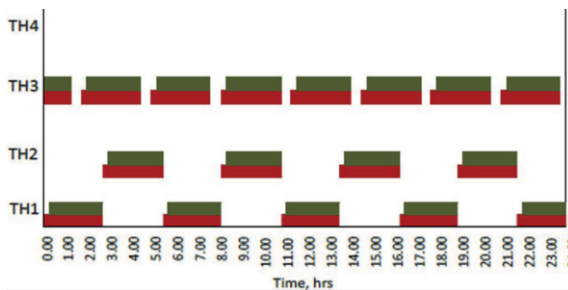

Figure 9.7 Triple taphole operation in a blast furnace (4400 m³ IV, production 2.2 tHM/m³IV.24hrs, slag rate 500 kg/tHM)

Example 9.2 Simulation of cast duration and hearth level

Cast duration and hearth level can be estimated with a simulation model (originally developed by Molenaar and published in Opbergen and Toxopeus, 1999). In the simulation model, the effects of taphole length, drill diameter, clay wear and gap time are considered. The model has been calibrated with observations at numerous furnaces. It provides very reliable results and helps to understand the effects of various measures. In the present example the production data of the reference furnace are used. The furnace is casting excellently with a wear resistant clay.

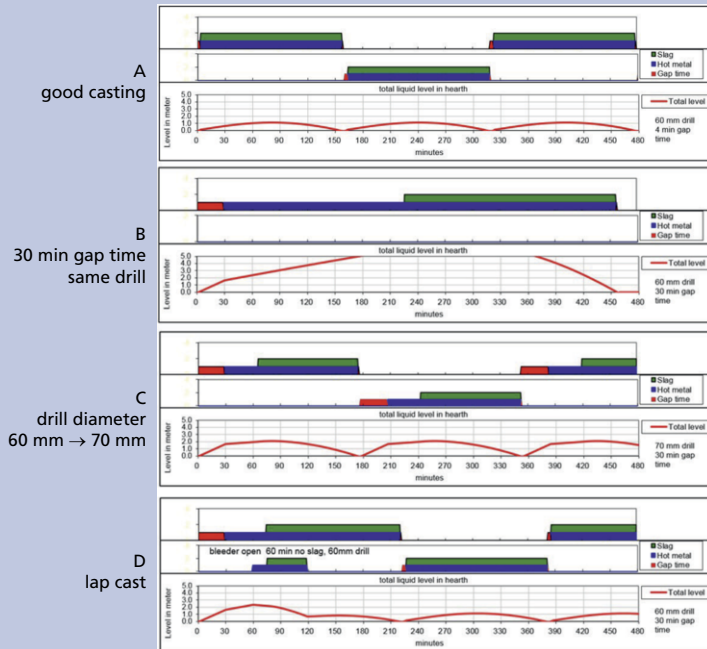

Figure 9.8 Effect of gap time on cast duration, liquid level and slag coverage

Figure 9.8 shows the effect of a 30 minute gap time. Figure 9.8a shows good casting with duration of 150 minutes, a highest level of liquids of 1 m above the taphole and nearly 100 % slag coverage (time slag/time hot metal). If after a 30 minute gap time, the cast is opened with the same drill diameter, casting gets out of control as shown in Figure 9.8b: slag tapping starts after 200 minutes and the slag is already above tuyere level. There are three options for remedial action:

1. Increase drill bit from 60 mm to 70 mm, as shown in Figure 9.8c. Nevertheless, the highest level in the furnace will rise to 2 meters and slag coverage will be reduced to 80 %. This can be only be done before the taphole is drilled. If not:

2. Open a lap cast: open another taphole to enforce liquid drainage (Figure 9.8d). This is normally done when there is no slag flow for 60 minutes after closing the previous taphole. Liquid level reaches 2.5 meters above taphole level. If this is not possible:
3. Reduce production rate, while keeping maximum top pressure.

If a furnace is casting on one side only, with 30 minutes gap time, the model results are identical to those in Figure 9.8c – an increase in the highest level from 1 to more than 2 meters above the taphole and a decrease of slag coverage.

Estimations can be made on the basis of the model of cast duration as being dependent on various casting parameters. Another aspect is wear of clay, because taphole diameter increases during slag casting, in Figure 9.8 good clay was used. Comparison with slightly poorer clay is shown in Figure 9.9. The cast with poorer clay was opened with a smaller drill diameter to achieve a similar duration. Although the casts look very similar, there are large differences: with poorer clay the hot metal and flows are smaller at the beginning of a cast. With poor clay slag flow almost disappears during the cast, and finally the slag flow is much larger at the end. This large flow at the end of a cast leads to more slag being retained inside the furnace at a blow. The maximum level increases from 1 meter for good clay to 1.5 meters for poorer clay, which is increased by an unknown amount because more slag is retained.

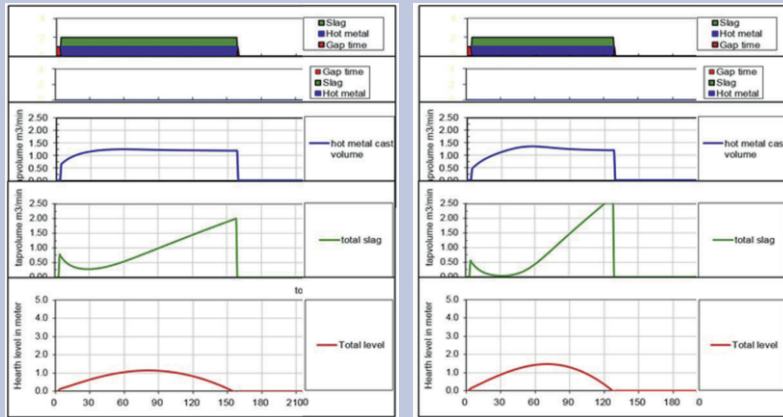

Figure 9.9 Effect of clay quality on casting
 Left: good clay, wear 0.15 mm/min
 Right: slightly poorer clay, wear 0.3 mm/min

A special situation occurs when two operating tapholes have a different taphole length. Due to the fact that a taphole has an inclination of 8–12 degrees, a difference in taphole length causes casting at a different level in the furnace. The shorter taphole has a higher slag/hot metal ratio than the longer one. Also, the cast duration is enlarged at the longer taphole. Consistency is important: if taphole length decreases, less liquids can be cast, if taphole length increases, more liquids can be tapped and there will be a slag delay. And adjusting from short to long taphole by plugging more clay is very slow and not very predictable.

Real flows of hot metal and slag as measured for hot metal from the descending velocity of ladles and for slag from the temperature increase of the granulation water are used to calculate the liquid level in the furnace as in Figure 9.10. The casthouse is very well operated. Note the increase in slag and hot metal flows from the beginning of a cast onwards. This type of data was used for developing the model mentioned here.

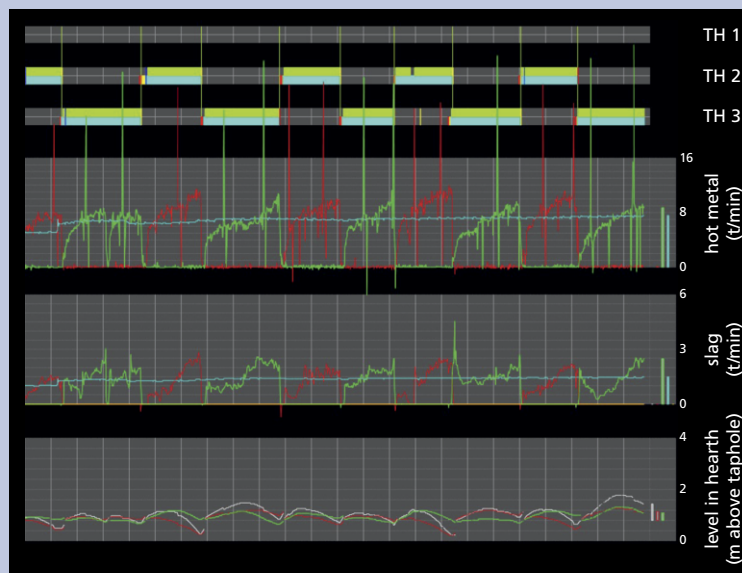

Figure 9.10 Typical casting with a dual taphole operation in a three taphole furnace, showing hot metal and slag run times at top and hot metal flow, slag flow and hearth liquid level (4400 m³ blast furnace)

9.4 The taphole

The tapholes are the most vulnerable areas of the blast furnace due to the constant wear and tear and reliance on consumable materials, equipment, and manual intervention. If any of these factors are performing less than optimally, then deterioration in the taphole performance is the likely result. Taphole heights are drawn at the outside, but tapholes are drilled under an angle sloping 8–12 degrees downwards. A slope of 10 degrees means that for every meter drill length, the taphole enters 17 cm lower inside the furnace. The larger the angle, the deeper the furnace is cast, and the more hearth volume is available, but the more the liquid splashes into the runner system, which causes wear and affects hot metal–slag separation.

The taphole itself has to fulfill the following conditions (see Figure 9.11):

1. Consistent in length, since length affects casting behavior.
2. Consistent in diameter for reliable consistent volume flow. Minimum wear of diameter during cast discussed above, although some minor wear helps to secure a dry hearth.
3. Smooth inner surface since a coarse inner surface causes additional turbulence in the taphole which leads to more resistance and then drill diameter will become larger than required.
4. No gas leakage, as gas leakage will cause spraying casts and jeopardize the “blow” indication. Cracks in the refractory material of the taphole are unavoidable. For this reason, the working methods and taphole clay have to be designed for “crack–healing”.
5. No “secondary” cracks with liquid connection: a liquid connection in the final 1.5 m of a taphole will lead to false blows.
6. No hot metal and slag left in taphole after plugging, because this makes drilling the next cast difficult and may lead to oxygen lancing of the taphole.

In order to meet all these conditions, the total system of taphole length, clay quality, plugging, taphole face, drilling and working methods have to be considered.

Taphole length

The taphole end has to be located at a point where flow of liquids towards it is assured, so it has to be in a pool of liquids with good permeable coke. It is not too far inside, because the deadman has little coke voidage, and it is not too close to the wall, since hot metal flow along the wall wears the refractory. The location has to be found empirically, but will probably be somewhere in the area of the end of the raceway above it. Typically, the raceway is 180 cm and tuyeres are 40 cm inside, to which have to be added the thickness of the refractory (for example 70 cm plus shell and chapel, for example 50 cm), so in total somewhat less than 340 cm from the taphole front. But note, taphole length is determined by furnace design and chapel design, so the optimum is furnace–dependent. A longer taphole can have a higher resistance and may be opened with a slightly larger drill diameter.

A sketch of an operating taphole is shown in Figure 9.11. In the sketch, a number of taphole issues are indicated, from the inside of the furnace to the outside the following should be mentioned:

- The taphole is drilled through solid material, basically skull with some refractory in it. It is a relatively unstable structure so cracks can form. When a crack forms, it starts to drain liquid from a higher level – a “secondary taphole” is formed. This will give a false blow as soon as gas reaches the secondary taphole. As a consequence, the next cast on another taphole will cast hot metal only for a prolonged period and thus with poor slag coverage.
- The taphole passes through the hearth wall refractory. These refractories can become slightly porous and can lead to gas leakage into the taphole, because pressure in the furnace is much higher than the pressure in the taphole. Especially along the refractory boundaries, gas leakage can occur. The taphole wears during casting, which means increases in diameter, and gas leakage can increase during casting. Gas leakage into the taphole causes additional wear, reduces the casting rate, and makes the cast spray.
- The refractories are cooled and thus the curing of taphole clay on this position is impeded. This is the place where operators often find “wet spots”.

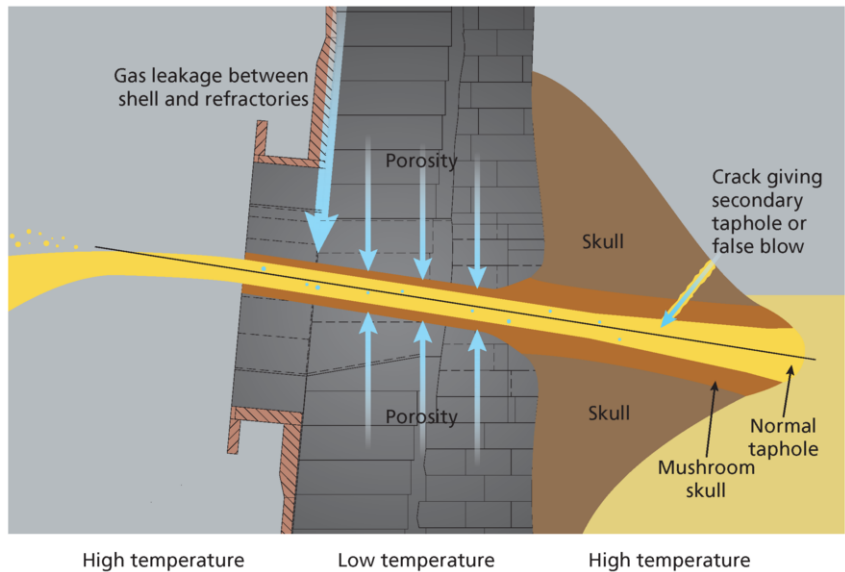

Figure 9.11 Taphole in operation, showing gas leakage into the taphole and secondary taphole via crack. High and low temperature refer to refractory temperature – low temperature results in slow curing of clay.

Taphole clay

Taphole clay has to be gas-tight, resistant to wear, mainly by liquid slag, capable of filling cracks and capable of pushing hot metal and slag from the taphole when plugging. Example 9.3 describes the components of taphole clay. A dense material is required. It has to be hard clay (which means plasticity as low as possible), so that the gun can just push the clay into the taphole at

maximum compression. This has as the consequence that taphole clay has to be used at a constant temperature. This means: storage in stock as well in the clay gun at constant temperature by water cooling/heating. By doing this, the effects of the parking position of the gun as well as seasonal influences are eliminated.

Tar-bonded and resin-bonded clays have different properties. Resin-bonded clay cures 10–20 times faster than tar-bonded. This is an advantage for having the taphole available quickly, but also a disadvantage since post-pressing is not readily possible, so that tar-bonded may lead to better gas-sealing by improved penetration into cracks.

Plugging

Plugging is pushing the taphole clay into the taphole and in so doing removing all hot metal and slag from it. Any remaining drops of hot metal will jeopardize proper opening of the next cast. In order to remove the liquids, the refractory material has to be pushed in in a controlled way, so with a constant volume/second which can be realized with automated control of the pressure of the clay gun piston. Best results are obtained with a very smooth taphole interior without any irregularities.

A major problem of plugging is clay spillage. As soon as clay is spilled, the internal compression of the clay is lost and plugging is poor. In order to prevent clay spillage, the following conditions have to be met.

1. Flat and smooth taphole face perpendicular to the taphole.
2. Adequate sealing of the furnace to the face by having sufficient pressure from the slew mechanism of the gun on the taphole nozzle towards the furnace.

Example 9.3 Taphole clay composition

Taphole clay is a mixture of a number of different materials with varying size distribution. Since taphole clay has to be dense, the aggregate particle size distribution of the blend of different materials has to fulfill the requirements of the Fuller distribution for maximum compactness. Moreover, the largest particles in the blend still have to be very fine (smaller than 0.5–1 mm), so that material can be pressed into cracks.

Taphole clay contains:

1. SiO_2 – is a filler material, that can be minimized because it dissolves in slag.
2. Carbon-bonding – tar and/or resin can be used for gluing the particles together. Use a minimum, since excess leads to increased wear.
3. Al_2O_3 – three qualities of Al_2O_3 are available normal, fused and sintered; they all can be used, with the sintered giving the best results and being the most expensive. Al_2O_3 lends mechanical strength to the clay.
4. Ferro Silicon Nitride (FeSi_3N_4) – facilitates taphole stability, does not react, and its quality can be quite variable. It is expensive – can be 30 % of volume.
5. SiC – reacts with FeO in slag, expands and facilitates lower porosity.

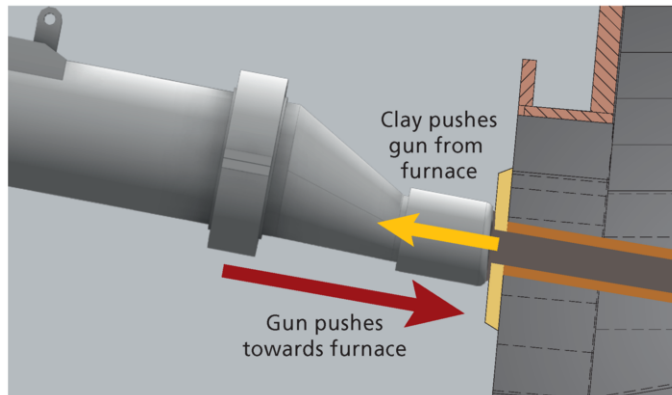

Figure 9.12 Hydraulic pressure pushes the nozzle to the furnace, the piston compresses the clay into the taphole causing a counter force caused by friction and the pressure of gas and liquids

This overcomes the counterpressure of the clay that pushes the gun from the furnace. (Figure 9.12). To this end, the width of the steel of the nozzle of the gun should not be too large, typically not more than 3 to 4 cm. Sealing requires a compressible surface between taphole face and nozzle of the gun for which a wooden laminated ring can be used mounted on the gun.

Clay spillage prevents proper plugging. But in addition: the taphole face can be damaged when the spillage is removed by oxygen lancing. This is costly, difficult to do, causes additional damage and usually costs production time.

When the cast has to be plugged, the clay gun is moved in front of the taphole. The movement of the gun has to slow down to prevent collision with the taphole face, but as soon as it touches the taphole face the clay has to be pushed into the taphole. The next step is to push a defined amount of clay into the furnace after which the piston movement of the gun stops. Shortly thereafter the compression in the clay decreases. In order to fill small cracks in the refractory, postpressing has to be applied: this is a very short push of the piston, so that only the pressure increases, filling the gaps, but the clay does not move. Movement will destroy the clay structure. Proper post–pressing has to be automated, since optimization of manual postpressing by an operator is not feasible. While the clay is curing in the taphole, there are three zones: in the furnace the temperature is high and curing is fast, in the cooled refractory the temperature is lower and curing is slow, and in the chapel the temperature is slightly higher again and the curing is good, but slower than inside the furnace. Plugging is summarized in Figure 9.13 on the next page.

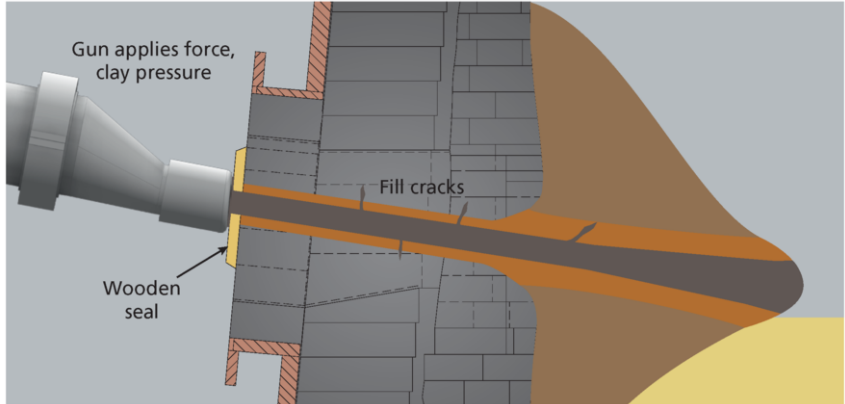

Figure 9.13 Clay being pushed into the taphole

Taphole face

The quality of the taphole face and the pressure of the clay gun determine clay spillage. The taphole face has to be strong, smooth and have a long service life, so that it does not need intermediate repairs. Taphole face can easily be damaged by the collision with the clay gun the moment it touches the face. For this reason, the movement of the gun towards the taphole face should slow down for the final 10 cm and the pressure should increase the moment the gun touches the face. At the very same moment the clay has to be discharged into the taphole. This has to be an automatic control. Only the very best castable refractories are suitable for the taphole face.

Drilling

Cured taphole clay is brittle material, which every operator can check by himself. Smooth drilling in brittle material requires a slow and constant forward movement. This has to be (automatically) controlled in the drill system. Fast forward movement on a certain position, or very slow movement, will damage the smoothness of the taphole. If properly plugged, hammering is not needed. Hammering will severely damage the taphole wall.

An appropriate drill bit is required to have a straight taphole. The drill bit has to guide itself through the taphole as in figure 9.14b. Drill bit A has no self-guidance and bending of the drill shaft will cause a change in direction of the taphole. The drill will find a path with least resistance in the cured clay, which can deviate from the intended taphole direction. Drill bit B has self-guidance, that together with a stiff drill shaft will follow the path of the intended taphole.

During drilling wear of the drill bit has to be prevented. To this end the drill bit has to be cooled, but cooling with air will burn the bit because of the oxygen, so cooling has to be done with nitrogen, which has increased heat capacity by adding water mist to it. The water addition has to be stopped as soon as nitrogen flow stops to prevent water in the taphole.

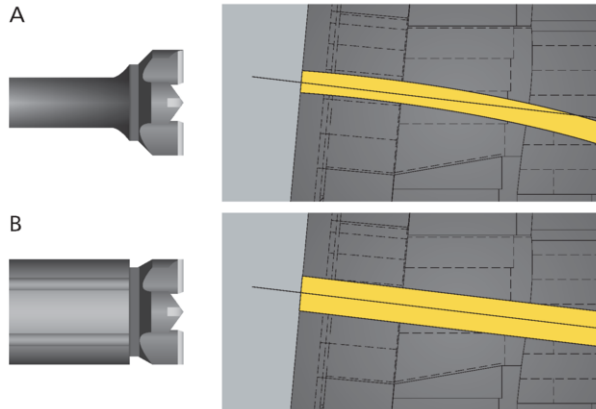

Figure 9.14 Drill bits used for opening taphole

As taphole lengths are around 3.5 meters, drill rods will have a length of around 4 meters. During drilling, force is used to push the drill forward. This will lead to bending of the drill rod which prevents the drill from following a straight path into the furnace, causes the drill to oscillate and creates a larger taphole diameter than the drill bit size. To avoid this, the drill machine has to be equipped with a guiding system at the front and halfway along the sledge of the drill machine.

9.5 Single taphole furnaces

Furnaces with only one taphole are of course optimized for tapping single sided. These furnaces are in general small furnaces and in practice these furnaces are less vulnerable to increased gap times. This can be explained by the relatively much smaller deadman and the smaller distance to the other side of the furnace, so the slag liquid inclination in the furnace is more level. Moreover, these furnaces have a larger average voidance in the hearth than large furnaces due to the stronger vertical movement of coke in the hearth. For single taphole furnaces, the clay type has to wear more quickly, because the wearing of the clay makes the casting flow, especially for increased slag, and is a kind of safety valve to ensure that liquids are removed.

In single taphole furnaces the minimum gap time is often dictated by the curing time for the clay. If the taphole is opened before the clay has hardened, much of it will easily wash away, which will quickly erode the taphole mushroom and expose the taphole refractory block itself. For this reason, many single taphole furnace use resin-bonded type clay that hardens quickly.

9.6 Casting problems and remedial actions

General remarks

In the event of casthouse problems, use is sometimes made of a larger drill bit to open the taphole. It should be kept in mind, that recuperation of the originally smaller diameter takes time. For example, from experience: after drilling a 10 mm larger taphole, so 60 mm for instance instead of 50 mm, the taphole diameter recuperates only 1 mm at the taphole wall per cast, so 2 mm in diameter. So, it takes five casts to come back to the original drill diameter. A second remark on production level: When the casthouse can no longer cast all liquids, the production has to be decreased by reducing blast volume. In that situation, the top pressure should be retained on the furnace in order to keep pressure on the taphole as high as possible for liquid flow. Note, that in the event of external demands to lower the production, the operator has to try to keep the gas flow through the furnace consistent. This can be done by decreasing top pressure. In practical terms: decrease the top pressure to the extent that the wind velocity in the tuyeres is constant. So, handling top pressure in case of delays depends on the particular problem.

Casting delay

In the case where the operator is faced with a casting delay, different actions may be taken depending on the current condition of the blast furnace. The next cast can be opened with a larger drill diameter or the production rate can be decreased. See Example 9.2 above.

No slag casting

As soon as slag is not draining properly from the furnace, the following measures can be taken:

- Using a larger diameter drill bit on the next cast will increase the flow, and may improve the situation.
- Changing to the other taphole may improve the situation inside the furnace.
- Opening the second taphole, so two tapholes are open at the same time (overlap casting), should be done after a defined period of no slag casting as specified in the standard operating procedures for the plant, mostly 60 minutes after plugging the previous cast.
- Reduction of production level by decreasing blast volume and/or oxygen enrichment.
- Shorter gap time.

Not dry casts

A cast that has ended before all the liquids have been drained from the hearth is described as a not dry cast. Depending on the cause of the not dry cast, slightly different reactions may be appropriate. Where the not dry cast is known because the taphole is closed for operational reasons, the second taphole should be opened immediately with a larger drill bit. Where this is not possible, the oxygen and then wind rate should be reduced and the original taphole re-opened as soon as possible. Where this is not possible, the decision to close the

taphole should be delayed as much as possible, with wind rate being reduced as far as liquid levels, as seen at the tuyeres, will allow. At this point there is a balance between how much damage is being caused outside the furnace due, for example, to molten metal spill, compared to the danger of flooding tuyeres with slag and hot metal. Timely action for wind reduction is required in order to prevent major damage.

In cases where the taphole has shown signs of the hearth being empty, but it is thought from the casting times and amount of slag cast that this is not the case, then there are a few different actions that may be considered. If there is a second taphole available, then it may be opened prior to the first taphole being closed. Once this is safely open, the first one may then be closed, known as overlap casting. Alternatively, the normal gap time between casts may be reduced to zero, so the second taphole is opened immediately after the first is closed. It is important to ensure that both tapholes do not finish casting at the same time as this will introduce a necessary gap time when there are two clay guns in the taphole waiting for the clay to harden. So, once slag appears at one of the tapholes, it should be closed to allow the other to cast normally. This technique of when to open and when to close a second taphole should be included in the standard operating procedure for casting to ensure that the best sequence, proven in practice, is followed by all operators.

These same actions may also be taken if the blast pressure is affected by a possible build-up of slag in the furnace. At the same time, however, other causes of increasing blast pressure should also be investigated.

One-side casting

The single most important effect of single taphole casting compared to alternate casting is that of the gap time. During the gap time the furnace is still producing liquids but not casting. Ideally the gap time is calculated as the optimum to allow liquid accumulation for a smooth cast of the expected duration with controlled liquid level. However, the gap time can also be affected by external factors such as how long it takes to change torpedo ladles, clay curing time, maintaining and cleaning the runner system. It is very important to remember that the furnace is still producing liquids at the same rate, unless a change is made to slow down the production.

If a furnace must switch from alternate to single-sided casting, gap times will vary considerably between the two practices. If alternate casting requires a gap time shorter than the time it takes for the clay to harden, then single casting will require a change in practice. If faster-curing clay is available, then this may be applied, but caution should be used during the transition as the clay already in the hole may not combine well with the new clay.

If there is a significant difference in the gap time, the production rate has to be reduced to minimize the fluctuation in hearth liquid levels. Experience has shown that single taphole operation can sustain production levels of up to

5500–6000 tHM per day for a 2800 m³ IV blast furnace and 8000 tHM per day for a 4400 m³ IV blast furnace when operated at low slag volumes (below 250 kg/tHM). This is often a significant reduction compared with what the furnace is usually producing. The reason is, that the production rate may not exceed the drainage capabilities.

Oxygen lancing

On occasion, opening the taphole using oxygen lancing is unavoidable. This practice should be considered a last resort as it is extremely damaging to the taphole refractory. Where the use of oxygen lances is increasing, the situation should be investigated very closely to identify and solve the root cause. Where oxygen lancing is unavoidable, it should only ever be done by experienced casthouse workers, following the pre-drilled hole to ensure that the lance is burning in a straight line down the center of the taphole. If more than one lance is required, the interval between the two should be as short as possible, with the practice continuing until the taphole has been opened. Where this causes a long delay to the cast, alternative or additional actions such as opening a second taphole or reducing wind rate should be considered at an early stage. Repeated use of oxygen lances to open the taphole is likely to cause irreparable damage to the taphole area, and may even pre-empt a taphole break-out or necessitate an extensive taphole repair to avoid such a break-out. There is a very large risk associated with using oxygen lances as it is very difficult to ensure that the lance is burning in a straight line. Damage to the taphole block or to taphole staves are the biggest concern. Operators can practice oxygen lancing in a block of cured clay.

9.7 Hot metal and slag separation

Hot metal and slag separate outside the furnace in the runner system as illustrated in Figure 9.15. The trough or main runner will still hold liquids from the preceding cast, so when the hot metal from the next cast starts flowing, it will then increase the level in the runner. The hot metal already under the skimmer will also increase in height and start flowing again over the hot metal dam. This hot metal will then flow to the tilting runner and into a torpedo ladle. Once the ladle is full, the tilting runner will be repositioned into a torpedo ladle which is parked parallel to the full one, so this second ladle can also be filled. The full ladle will be removed and replaced by an empty ladle, so that the cast is not interrupted. This alternating between ladles via the tilting runner is done until the hearth is empty and the cast is complete.

The slag sits on top of the hot metal, so it does not flow under the skimmer as long as the separation remains good. Once it has reached a certain level in the trough it will flow over the slag dam and either to a slag granulator or to a slag pit or ladle. It is very important that hot metal is not allowed to go over the slag dam as this can result in explosions in the granulator, burning a hole in the slag ladle or difficulties in emptying the slag pit. For yield reasons, slag going into

- the torpedo ladle has to be prevented. Slag in the ladle can result in a solid slag skull at the mouth of the ladle, resulting in difficulty in pouring the hot metal at the steel plant. Best separation is reached by
- Laminar flow in the main runner, which means a cast rate just above the production rate. Flow in the main runner changes from turbulent to laminar as indicated in Figure 9.15.
 - Properly designed levels of runner bottom, skimmer, hot metal dam and slag dam, which are maintained at design specification. Note that the hot metal slag interface moves up and down in the trough depending on relative flows. This separation line has at all times to be 10 cm above the level of the skimmer opening and 10 cm below the slag dam level. The more stable the cast flow, the better the separation.

Improved separation leads to cost savings because of improved yield. Controlled casting with a good slag coverage leads as well to improved hot metal sulfur, since desulfurization of hot metal to a large extent takes place in the taphole (Chapter VIII).

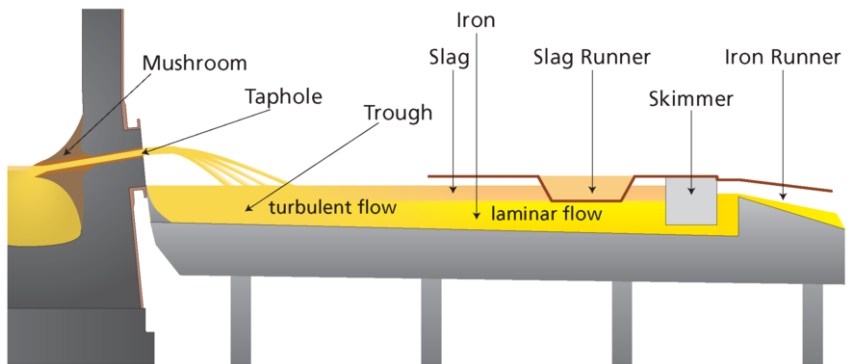

Figure 9.15 Slag and hot metal separation in the hot metal runner, or trough

This page intentionally left blank

X Control of Blast Furnace Operation and Burden Selection

10.1 Production level and reductant rate

The actual production level of a blast furnace is derived from the number of charges per hour and the hot metal quantity per charge. However, the production level has a delay compared to the momentary value, because monitoring charges per hour takes a few hours. In order to take into account short term variations in hot blast volume, oxygen enrichment, moisture and injectant rate, the real time production level has to be calculated from oxygen input into the tuyeres from air, enrichment oxygen, blast humidity and coal. This method assumes a fixed amount of hot blast oxygen per tonne of hot metal, called the specific oxygen rate. The specific oxygen rate is periodically updated based on charges per hour production rate and tuyere input oxygen. This method is not sensitive to shorter term changes in specific oxygen rate due, for example, to increased direct reduction; in this situation the calculated production rate will be incorrect. With a high accuracy top gas analysis system, it is possible to calculate the real time production rate from the oxygen balance from minute to minute. This gives a faster indication of when the production rate is changing. Constant monitoring of “expected” production and “real production” is required to find the reasons for changes, like an increased production rate caused by direct reduction, so that timely actions can be taken. Using charging rate works well for small changes in burden, but for large changes the delay between charged at the top and processing of the charged material 5–8 hours later has to be taken into account. Burden tracking in the furnace is helpful and is a standard part of most modern Level 2 monitoring systems

The operator needs to understand:

- production comes from oxygen blown into the blast furnace that gasifies about 340 kg/tHM of reductant; the 160 kg difference with the 500 kg reductant rate is for direct reduction (around 110 kg) and carbon dissolved in hot metal (around 50 kg).
- production decreases when less oxygen is blown into the furnace.
- production decreases when more reductant per tonne is used, for instance by increasing coal injection or charging a coke blank.
- production increases when direct reduction increases.

In general, the oxygen input through the tuyeres is closely monitored, although it is very difficult for the operator to get to know the real input of oxygen, as oxygen comes from hot blast, the oxygen flow for enrichment, the moisture in the hot blast (includes ambient moisture) and oxygen from coal. A standard Level 2 system will calculate this on-line by adding all oxygen input together, for instance in m^3 STP/min. It is also helpful if the control system of the furnace uses oxygen in a ratio to blast volume, so that a constant enrichment percentage is maintained when blast volume is reduced. Coal and gas injection should be controlled as kg/tHM.

It is already difficult for the operator in the control room to observe the oxygen input and thus the production level. It is even more difficult to observe the actual fuel rate used to produce a tonne of hot metal. The charged coke rate and injection rate are known, but coke used for direct reduction is difficult to observe when it is expressed as a direct reduction percentage. It is more helpful to express it in kg/tHM of coke. Rules of thumb can then be used to translate direct reduction, heat losses and changes in gas utilization to the required fuel rate. Or a mass and heat balance can be used for online calculations.

The blast furnace operates with aims for the most important process variables:

- Input through tuyeres: blast volume, hot blast temperature, oxygen enrichment of the hot blast, hot blast moisture (in g/m^3 STP), PCI rate and gas rate.
- Input at top: charge weights of the various materials (coke, sinter, pellets, lump, miscellaneous materials).

Since furnace efficiency and raw material quality are variable, production level and reductant rate have to be reviewed every shift. Remedial actions in case of deviations are documented in a system of standard operating procedures. This will work well as long as a furnace is under control.

Blast furnace operators have different practices with respect to the consistency of the production level. Most companies pay a lot of attention to keeping the blast volume constant for weeks. These companies have done, and are doing, a lot to keep the quality of raw materials consistent, to eliminate all mechanical delays and to automate working methods. It is certain that this practice leads to very good operational results. Different companies are more flexible and change blast volume if and when required several times per week. They will allow burden quality to change if there are opportunities in procurement, will try to reach very low coke rate and will change to a slightly higher coke rate if permeability deteriorates. Wind volume aims at production, that the steel plant can process. These companies have standard operating procedures for 10 or 20 % lower production rates and feel confident in stopping a furnace; the blast furnace is seen as quite forgiving. Besides technical reasons between these two modes of operation, like the capacity of the steel plant, there are as well cultural differences. But note that some of the more flexible companies are also performing excellently and can reach considerable cost advantages by making use of procurement opportunities and avoiding plating of hot metal.

10.2 Under control and out of control

Blast furnace operation can change in a short timespan to a situation where the process is no longer under control and actions for returning the furnace to normal operation are required.

For instance, the thermal state of a blast furnace can change dramatically in few hours. An example is shown in Figure 10.1, where hot metal temperature decreased from 1440 °C to below 1390 °C in less than 10 hours. The operator may well have reacted according to the standard operating procedures, but still the furnace chilled. Most important is, that an operator recognizes the situation from burden descent (slippery), sudden high cooling losses (double normal values, localized peaks) or very low gas utilization (some 4 % below average) or very low hot metal temperature or silicon. Remedial actions are:

- Continue casting, high residual level can cause the furnace to get out of control.
- Decrease blast volume to the minimum where fuel injection can be maintained on the furnace. Being out of control is always related to poor melting of the ferrous burden and, by lowering the blast volume, there is more time for melting and improved heat transfer from bosh gas.
- Lower basicity. A lower basicity makes the slag liquid at lower temperatures. A lower basicity may be more important than the next point.
- Increase reductant rate by increasing coal injection (around 20 kg/tHM), while preventing too low T_{flame} .
- Increase reductant rate by charging more coke. Charging coke blanks is to be preferred over increasing coke rate, because it reaches the cohesive zone faster.

Most plants have ‘red button’ procedures to take these actions, which are considerably more aggressive than the standard thermal control procedures, to prevent such situations as above from occurring, if there are indications of severe cooling. The objective is to provide a significant boost to heat in the bosh gas, thus an immediate boost to heat in the lower zone, to bring the furnace back to a safe state by replacing the lost reserve of coke below the melting zone, and to reduce slag liquidus in case the hearth cools.

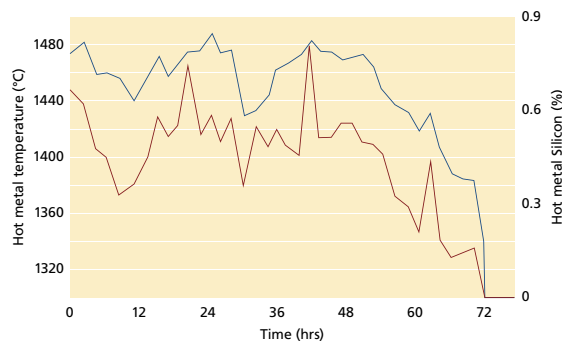

Figure 10.1 Thermal state of a blast furnace during an upset (the blue line represents the hot metal temperature, the red line hot metal silicon level)

10.3 What to control in daily operations?

The blast furnace must be constantly monitored to ensure that the fuel input is correct and that the product is within the required quality parameters. Key areas of control are:

1. Thermal control: temperature and/or silicon of the hot metal.
2. Control of slag composition, appropriate inputs to be selected for desired slag composition.
3. Control of hot blast parameters and injection at the tuyere level.
4. Gas flow control by burden distribution

For some control parameters automatic control is the best (or only) possibility. Examples are given in Section 10.8 of this chapter.

10.4 Thermal control

The thermal state of the furnace is adjusted on the basis of hot metal silicon and/or temperature. Different companies use different methods, but in general there are two casts below or above an acceptable range required in order to make adjustments. Adjustments can be made by changing PCI/injectant rate or coke rate at the top. If adjustments are based on two casts, average response times are more than 7 hours if done with PCI and more than 12 hours if based on charged coke weight. This is a slow reactive adjustment process.

Online and continuous hot metal temperature measurements are used to speed up the thermal adjustments. Example 10.1 shows continuous hot metal temperature measurements.

More proactive thermal control is based on the observation that thermal changes are often caused by a change in direct reduction. Online monitoring of direct reduction (or the heat balance over the lower furnace) can recommend thermal control actions. For example: if direct reduction increases and the burden descent is higher than expected on the basis of the oxygen input, the furnace will cool down. There is no need to wait for the hot metal temperature to decrease before taking appropriate action. So, immediate actions like increasing the PCI rate by 10–20 kg/tHM (preferably at constant T_{flame} and oxygen input through the tuyeres) can be taken. Systems that calculate the heat balance over the lower furnace while on-line address the same subject and provide very reliable results in preventing thermal upsets. Unfortunately, companies express heat shortage in the lower furnace differently. Among the indicators used are: direct reduction percentage, gas reduction percentage, direct reduction in kg C/tHM and factor Ω (the difference between the η_{CO} on FeO level in operation compared to thermodynamic maximum). In some cases, the recommendations are implemented automatically.

Example 10.1 Continuous measurement of hot metal temperature

Hot metal temperature is generally measured with a thermocouple dipped in the iron runner directly after the skimmer. The temperature measurement has a delay to reach the value inside the furnace since the runner system has to get warm. Especially when casting alternately on two sides, the runner cools down for 2–2.5 hours between casts.

A relatively new development is continuous measurement (Figure 10.2). This can be done by observing the hot metal temperature after the skimmer by optical methods, but also by measuring with the optical methods right at the taphole. A thermocouple in a refractory based tube, installed in the center of the skimmer, can also be used, but has to be changed every few weeks. If hot metal temperature is measured at the taphole, the correct hot metal temperature is measured right from opening the cast. The temperature difference with measurement in the skimmer is caused by hot metal and slag cooling down in the main runner after closing the preceding cast.

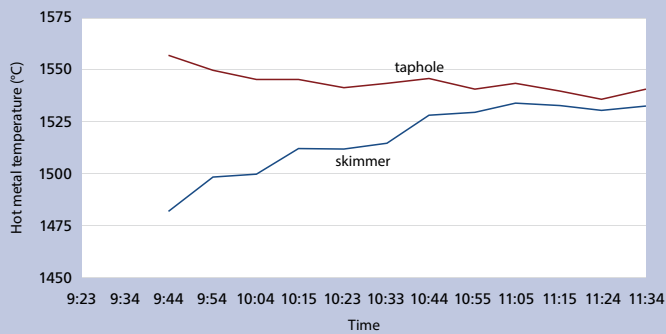

Figure 10.2 Example of continuous hot metal temperature at skimmer and taphole at a 3200 m³ blast furnace

10.5 Control of slag basicity

The chemical composition of slag is controlled by varying the burden input in order to reach the aim for slag basicity.

Changes have to be made:

- when raw material quality changes, for instance after receiving a new average chemical composition of sinter;
- when raw material quantities are changed;
- when a stop is planned;
- when calculated and measured basicity have too large deviation;
- when hot metal silicon changes to a new level due, for example, to a significant change in target production level.

Required basicity changes can be made by changing the charge weight with one or more materials. For instance, gravel or quartz can be used to adjust basicity, (more gravel gives a lower basicity), acid pellets can be exchanged with basic sinter. Limestone or dolomite can be used as well. However, operators tend to minimize use of these fluxes, since these materials have a penalty in coke use: decarbonization costs around 200 kg coke per tonne of limestone and around 150 kg coke per tonne of dolomite). Basicity changes are in most cases done once per shift and when needed.

10.6 Control of hot blast parameters and injectant at tuyere level

The raceway conditions are: blast volume and oxygen rate, the hot blast temperature, the moisture in the wind as well as the type and quantity of fuel injection (coal, gas).

Blast volume

Blast volume and oxygen rate determine production. Blast volume is to be decreased if:

- Blast pressure exceeds its maximum allowable value. Blast volume has to be decreased, preferably at a constant oxygen enrichment level. In order to keep the gas flow through the furnace stable, top pressure has to be decreased as well. Gas flow in the furnace is constant, if tuyere velocity is maintained.
- Burden descent is poor. A lower ΔP will help to stabilize burden descent. In this situation top pressure has to be maintained at maximum.
- Production is too high. If for internal (casthouse) or external (steel plant) reasons, the production level has to be decreased, blast volume has to be reduced. In this situation it can also be effective for maintaining stable gas flow in the furnace to reduce oxygen more than blast volume.
- Very cold furnace. If the furnace gets very cold, blast volume has to be reduced in order to have more time for heat transfer to, and melting of, the ferrous burden.

Hot blast temperature

Hot blast temperature is the cheapest method for getting energy into the blast furnace. For this reason, hot blast temperature is normally maintained at a maximum and there are few reasons to decrease it.

Moisture in hot blast.

Moisture in hot blast uses coke, and is normally kept to a minimum. It is an efficient method of thermal control, but can usually only be used in the case of a hot furnace. Since atmospheric moisture varies from day to night and from season to season, some companies prefer to work with some steam added to hot blast in order to maintain a constant moisture in hot blast. It can help in keeping RAFT constant and can be used in case of a cooling trend. Some companies use steam injection in hot blast only in the event of an emergency.

Coal and gas injection.

The coal and gas injection level is used extensively for thermal control. Besides needing criteria when to put additional fuel into the furnace, there is also a need for criteria to take it out again. Companies using co-injection of coal and natural gas have the option of increasing coal injection at constant T_{flame} by exchanging coal and gas injection (Geerdes, 2015).

10.7 Gas flow control

Since gas flows along the path of least resistance and the resistance is defined by the ferrous layers, ferrous layers should be kept stable as long as possible. This means that for smaller or larger changes in coke rate, the coke weight has to be changed and the ferrous base kept constant. An illustrative example showing a change in coke rate from 350 kg/tHM to 300 kg/tHM is presented in Table 10.1. The ore base is kept constant and coke base reduced. Experience has shown that relatively minor changes in burden distribution will be required for optimization of the central gas flow (i.e. coke distribution). The burden distribution adjustments can be applied as a second step if required.

		Previous	Ferrous base constant	Coke base constant
Coke rate	kg/tHM	350	300	300
PCI rate	kg/tHM	143	200	200
Coke base	t	30.3	25.5	30.3
Ferrous base	t	136	136	162

Table 10.1 Coke base change when PCI rate changes

For daily gas flow control, it is sufficient to increase or decrease the amount of central coke. Indicators of too much central coke are a relatively inefficient furnace (too much gas flow in center) and a low position of the cohesive zone, as indicated by very low heat losses in the bosh. Too little central coke is shown from peaks in the heat losses at stable burden descent, which can also be observed from pressure taps showing the same pressure on various levels (short circuiting of gas flow along the wall). Table 10.1 gives examples of burden distribution control schedules. If more central gas flow is required, Coke 3 replaces Coke 2. Replacing Coke 2 with Coke 1 reduces central gas flow.

	Position	11	10	9	8	7	6	5	4	3	2	1	
		Wall						Center					
Coke 1	Less central	–	14 %	14 %	16 %	14 %	14 %	14 %	–	6 %	–	8 %	
Coke 2	Normal	–	14 %	14 %	14 %	14 %	14 %	14 %	–	6 %	–	10 %	
Coke 3	More central	–	14 %	14 %	12 %	14 %	14 %	14 %	–	6 %	–	12 %	
Ore		16 %	16 %	16 %	12 %	10 %	10 %	10 %	10 %				

Table 10.2 Bell-less top charging schedules with varying central gas flow

10.8 What should be controlled automatically?

There are numerous control loops in a blast furnace, but some controls cannot be done in manual mode by an operator. There are numerous control loops already automated. Here a few control loops are mentioned, where automation may not be self-evident. Important control loops to be automated are:

- Adjustment of material flow gate opening. When discharging material via the bell-less top, the opening of the material flow gate determines the flow rate. If something changes in raw material quality, the flows change, which should be automatically corrected. If not, the amount of coke charged in the center will fluctuate strongly, affecting central gas flow and furnace behavior.
- Plugging the taphole. Movement of the clay gun into the taphole face, compression and post-pressing can only be done systematically when automated.
- Drilling the taphole. Drilling with a constant forward velocity requires automated control.
- Blast volume and maximum ΔP . Ensuring that a blast furnace will not exceed its maximum ΔP can be automated. In practice it may mean that the blower is switched from (usual) volume control to (incidental) pressure control.

10.9 Burden selection

10.9.1 Burden composition international comparison

In expanding production facilities, especially in China, more and more locally produced pellets are put into the burden. What is the optimum burden composition? The answer to the question depends on the local cost situation. Here we address the metallurgical possibilities. In a sense this section covers many of the aspects in preceding chapters.

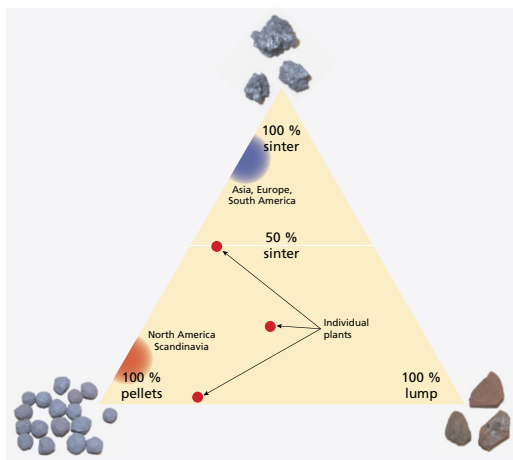

Figure 10.3 International comparison of burden composition

The total burden consists of sinter, pellets and lump ore in varying fractions as shown in Figure 10.3. The sinter content in the burden varies from no sinter to 90 %. Pellet content can reach 95 %. Lump ore has an acid gangue consisting of SiO_2 and some Al_2O_3 and is used mostly up to 10 % of the burden with few exceptions of up to 40 %.

With increasing pellet content, the choices that have to be made are:

- Acid or fluxed pellets, for acid pellets there exists a high MgO variant.
- What basicity of sinter has to be made.
- The type and amount of lump ore.

Optimization requires that the quality of the materials is suitable for high productivity and low coke rates. To this end fluxes have to be incorporated within the blast furnace burden materials and not charged directly into the furnace as limestone or dolomite. As a next step costs have to be optimised.

It should be clear from this book, that softening and melting behavior of the ferrous burden is critical for efficient operation of the blast furnace. The problem is, that softening and melting of blends is not a simple average of the softening of components. The question of burden optimization in this section is addressed by discussing the following topics.

- Reduction of burden materials in the “dry” area of the blast furnace, that is before softening.
- Softening and melting of pellets and sinter.
- Softening and melting of blends of pellets and sinter.

10.9.2 Gas composition in the furnace

Reduction of each blast furnace burden component is characterized by its “reducibility” (Chapter III). However, since the blast furnace burden is processed relatively slowly, a final stage of reduction prior to softening of the burden is reached, which is (almost) independent of the reducibility of the various materials in the early stage of reduction

Gas composition in a blast furnace can be monitored by vertical sampling in the furnace, Figure 10.4 on the next page. Temperature is measured with a thermocouple, gas is sampled and analyzed outside the furnace. Temperature and gas composition show different behavior: at the wall the temperatures are lower and η_{CO} is higher.

The figure shows the thermal and chemical reserve zone in the upper and lower graphs, especially in the sample 0.3 meters from the wall: for 120 minutes the gas temperature is 900–1000 °C and η_{CO} is around 30 %. There is a large difference in gas composition versus time between various radial positions.

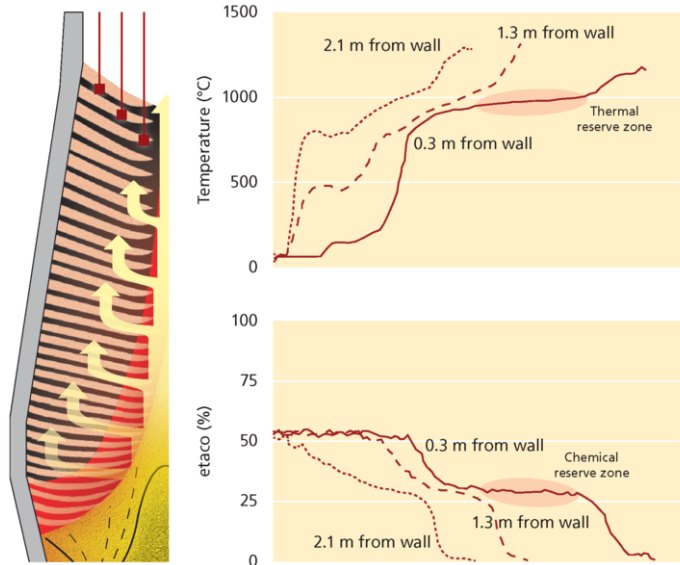

Figure 10.4 Vertical probes measuring temperature and gas composition in an operating blast furnace with 2678 m³ IV, average of several measurements (Chaigneau et al, 2001)

However, the two graphs in Figure 10.4 can be combined to show how η_{CO} varies with temperature as shown in Figure 10.5. For the various radial positions, the relationship temperature– η_{CO} is identical, where between 1000–800 °C the line corresponds with chemical equilibrium for the reduction of wustite. The conclusion is that gas composition η_{CO} is only dependent on temperature.

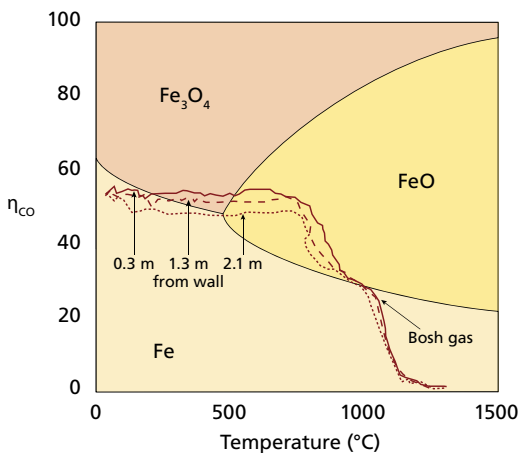

Figure 10.5 Vertical probes measuring temperatures and gas composition showing the relation temperature– η_{CO} , the arrow indicates bosh gas entering into the system

10.9.3 Reduction of the ferrous burden

The preceding section was about gas composition inside the furnace. What about the reduction of the burden materials? The behavior of the burden materials is analyzed in various reduction–softening–melting tests, which vary greatly in purpose and methodology. Here the behavior of burden components and the total burden is described.

The behavior was studied by reducing, softening and melting burden component and the complete burden in a test rig. A sample was reduced with a predefined gas composition/temperature pattern. Figure 10.6 shows the reduction behavior of fluxed sinter ($B_2 = 1.9$), acid pellets and two types of lump ore. In the early stage of the reduction there is a large difference in the reduction of the raw materials. Acid pellets and lump ore 2 are reduced fast, sinter somewhat slower and lump 1 lags behind in reduction. However, as soon as the temperature approaches $950\text{ }^\circ\text{C}$, the reduction of various materials is equal and the reduction reaches the wustite level ($\text{FeO}_{1.05}$).

The burden (60 % sinter, 20 % acid pellets, 10 % lump 1, 10 % lump 2) showed a weighted average behavior up to that temperature. The conclusion is that various types of materials show the same degree of reduction in the range of $950\text{--}1100\text{ }^\circ\text{C}$, even poorly reducible material like lump ore 1. At higher temperatures, differences are observed due to differences in softening temperatures, where the reduction rate of sinter is highest due to its higher softening temperature.

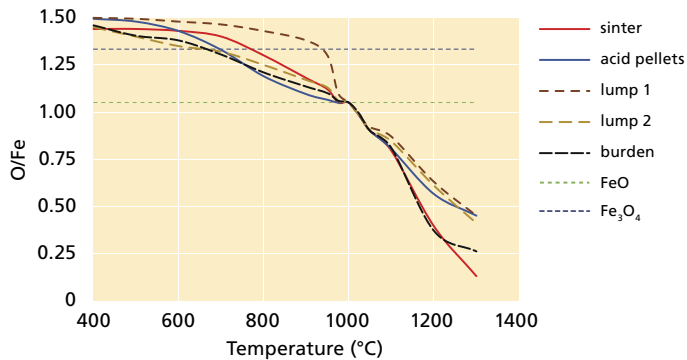

Figure 10.6 Reduction of fluxed sinter ($B_2 = 1.9$), acid pellets and two types of lump ore in a reduction test (Brass test, data from Chaigneau et al, 2005)

10.9.4 Softening and melting of sinter, pellets, lump

Softening temperatures are the temperatures where burden or its components tend to collapse. It can be measured from bed shrinkage or increase in gas resistance. No standard tests are available, but an impression of softening temperatures for various materials is provided in Figure 10.7 on the next page.

From high softening temperature to low:

- Super-fluxed sinter, softening at temperatures above 1330–1400 °C. After a melting test with a temperature above 1500 °C super-fluxed sinter is not completely molten due to the slag formed by its gangue.
- Fluxed sinter.
- Fluxed pellets.
- Olivine pellets.
- Acid pellets.
- Lump ore: lump ores have a very wide range of softening temperatures from below 950 °C to above 1300 °C due to variability in chemical composition and physical properties.

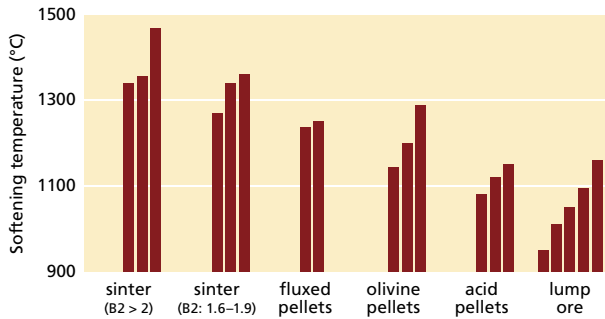

Figure 10.7 Softening temperatures of various types of burden materials compiled from various sources (Chaigneau et al, 2001, 2005; Liu et al, 2018, Kempainen et al, 2015, Etchevarne et al, 2018)

10.9.5 Softening of the burden as a blend of sinter, pellets, lump

Softening and melting of a blend is different from the softening of the components. As soon as material starts softening in a blast furnace, the internal structure collapses. However, the stronger material prevents the softening of the weaker materials by taking away the physical pressure from the burden on top.

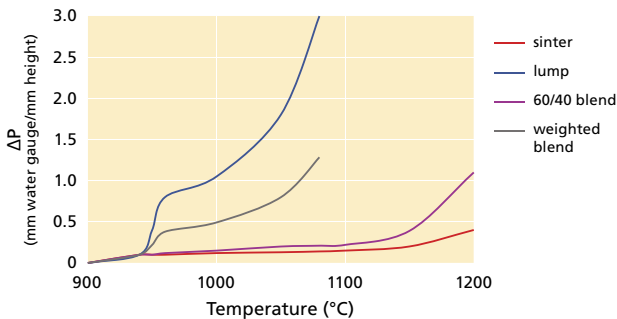

Figure 10.8 Softening of sinter and lump and its blend (60/40) as tested with a softening/melting test (Chaigneau et al, 2005)

The example of Figure 10.8 shows a sinter/lump ore blend (60/40 %), where sinter as the stronger material forms a skeleton. It prevents collapse of the cohesive zone and keeps the structure open and permeable for gas promoting reduction of the blend. A blend has softening properties similar to the stronger burden component. The unexpectedly good softening properties of blends compared to weighted averages were observed at numerous research projects.

10.9.6 Optimizing burden: sinter basicity and pellet type

Requirement for additional iron units comes especially from Chinese iron and steel industry, where additional pellets are produced. What type of pellets can be considered? Acid, acid/olivine or fluxed pellets and what sinter basicity? What are advantages and disadvantages?

Very high pellet rates (above 80%) require a proportion of fluxed pellets. This is the situation in North America and Scandinavia and specific plants elsewhere. High sinter rates (above 70%) can be combined with acid pellets, because it brings the sinter basicity into a good range. Sinter basicity is important for its metallurgical properties and also for sinter plant productivity. For high pellet operation in the range of 40–65 % pellets and 30–50 % sinter, options are:

- Acid pellets/super-fluxed sinter
- Olivine pellets/super-fluxed sinter
- Fluxed pellets/fluxed sinter

An analysis of these options starts with the mass balances, then the effects of costs have to be evaluated. It is clear from operating experience that the three options above are feasible, since companies with excellent performance for all variations exist. A simplified series of mass balances is based on starting points shown in Table 10.3. For optimization the slag, B3 (CaO+MgO)/SiO₂ was kept constant. The table also shows the scenarios for the use of acid, olivine and fluxed pellets.

	kg/tHM	CaO/SiO ₂	Fe	SiO ₂	CaO	MgO	Al ₂ O ₃	B3
pellet acid	785	0.30	65.0	4.0	1.2	0.4	0.6	
sinter	785	2.15	55.7	5.5	11.8	1.8	1.5	
slag	247	1.19		35.4	42.0	7.3	12.3	1.39
pellet olivine	783	0.08	64.6	4.0	0.3	2.0	0.4	
sinter	783	2.09	56.2	5.5	11.5	1.4	1.5	
slag	244	1.08		35.7	38.5	11.1	11.7	1.39
pellet fluxed	784	0.93	63.0	4.0	3.7	1.0	0.3	
sinter	784	1.66	57.9	5.5	9.1	1.4	1.5	
slag	245	1.17		35.8	41.8	8.0	11.4	1.39

Table 10.3 Comparison of pellet burdens and consequences for sinter composition. Starting points: 50/50 sinter/pellet burden, B3 = 1.39, pellets contain 4 % SiO₂, sinter ferrous content corrected for CaO content, 300 kg/tHM coke rate and 200 kg/tHM coal rate.

Sinter basicity for a 50/50 sinter/pellet ratio varies from 1.66 when using fluxed pellets to 2.15 when using acid pellets. Optimum slag MgO content is 8–10 % and all types of slag are acceptable.

What to choose? Most operators prefer a similar basicity for sinter and pellets and prefer to use fluxed pellets when the sinter rate decreases to below 60 %. There are, however, plants operating with super-fluxed sinter and acid pellets. Olivine pellets are metallurgically improved acid pellets. The advantages of the super-fluxed sinter with olivine or acid pellets are:

- Increased productivity of sinter plant (Chapter III) as well as pellet plant, since production of fluxed pellets costs energy for the decomposition reaction of carbonates driving off CO_2 .
- Acid pellets have a relatively low softening temperature, which can be improved by producing olivine pellets.
- Good permeability of the cohesive zone, since super-fluxed sinter softens at high temperature.

10.9.7 Burden distribution for high pellet operation

A high pellet percentage also requires consideration of burden distribution. The major effect of a big change in pellet percentage is the effect on the angle of repose: pellets have a shallower angle of repose than sinter. If a burden distribution is used that is insensitive to angles of repose, like the ideal burden distribution in Chapter VII, then the furnace will accept a different pellet percentage. If however, burden distribution makes use of angles of repose, like the burden distributions used for double bell furnaces in the past, which are sometimes known as “platform–V”, then changes in pellet percentage will be difficult to accept, since the increase in pellet% will lead to more pellets rolling into the center. This will block central gas flow. In such a situation the furnace will have to be operated on lower productivity and will operate with higher heat losses and lower PCI rates. This is explained in Figure 10.9.

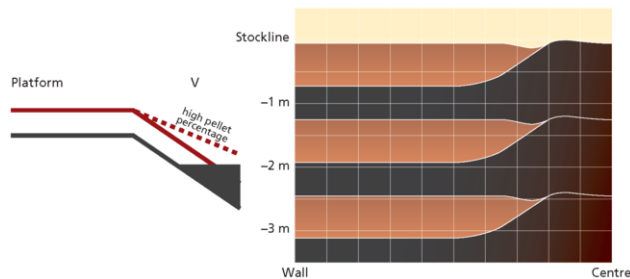

Figure 10.9 Left: effect of increasing pellet percentage on the ore free center, which is filled since pellets have a shallower angle of repose (ideal burden distribution as in Chapter VII for comparison)

XI Operational Challenges

11.1 Raw materials from stockyard: fines and moisture

The raw materials for an operating furnace are ideally freshly produced, skipped “hot” to the blast furnace and fulfil all quality requirements. Blast furnace operation, however, is often confronted with variability of the materials input. The percentage of various burden materials like sinter, pellets and lump has to change, or part of the materials comes from the stockyard. It has to be pointed out, that stockyard materials have different properties from freshly produced materials, especially with respect to the amount of fines and moisture. If the operator uses the ideal burden distribution as pointed out in Chapter VII, then the furnace is more robust in coping with raw material variation. Nevertheless, an operator should take appropriate measures if confronted with second grade raw materials. For instance, if a large percentage of sinter from stock is being used, the furnace cannot be expected to continue to run at maximum productivity, and timely reduction of blast volume is indicated. A large load of fines into the furnace may also come from direct charge materials like pellets when finishing a stockpile, or from very wet lump res, which are impossible to screen properly. In the present section, the effects of fines on the ore burden are discussed, as well as high moisture input, for instance caused by local heavy rain.

11.1.1 Fines in ore burden

For the blast furnace operator, one of the main raw material concerns is that of the fines loading. This is the proportion of undersize material that is in the furnace. The direct effect of a high fines loading is that it will affect the permeability of the furnace. The permeability of the ore layer is determined by the amount of fines (smaller than 5 mm) in that layer. Unfortunately, when bulk material is handled, fines are generated. For this reason, coke and ore burden are normally screened before being charged into the furnace. But, for example, when emptying a pellets stockpile or using sinter from stockyard, high fine loadings cannot be avoided. Especially if the material is wet, proper screening is difficult or even impossible. Wet lump ores can carry huge amount of “piggy-back” fines that adhere strongly to the larger particles and cannot be screened. In Chapter VII it was already noted that fines should be distributed over the furnace radius by using a large number of chute positions (7 or more) for the ferrous burden.

Fines tend to segregate. When material is put into the stockpile the fine material remains on the point of impact and the coarser material rolls outwards, the size segregation phenomenon. This effect is seen wherever granular material is handled. So, when reclaiming material from stock, it is important to avoid high amounts of fines being reclaimed and sent to the furnace without screening.

Similar segregation can take place while charging the furnace, and can impact the furnace process. Fines in general are undesirable, due to the blocking of the spaces between the larger particles, however due to the flow characteristics of fines, they can also deposit preferentially in certain areas. The impact of this is particularly noticeable with bell-charged furnaces, where the fine particles will drop directly down onto the stockline, and the large particles will flow a little more outward and deposit at the wall (see Figure 11.1). If material hits the wall before it reaches the burden level, the fines will accumulate close to the wall and the coarser material will flow inwards more.

This segregation effect also occurs when filling a bunker. Be it in the stockhouse or on the bell-less top, segregation will always take place. When material is charged into a bin, the fines remain on the point of impact, the coarse material runs “downhill”. If material is required from a bunker, it starts to deliver the material that is located in the center: this being the fine materials, while later the coarser materials from the sides of the hopper begin to flow. Finally, also the chute segregates coarse and fine materials with fines on the inside of the falling curve and coarse on the outside (Figure 11.1).

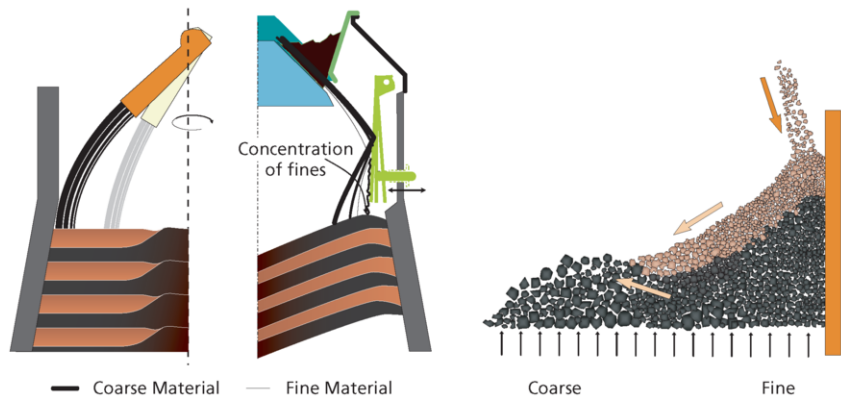

Figure 11.1 Segregation of fines during charging with a bell and bell-less top charging system. Right figure: coke pushed towards center.

A concentration of fines close to the wall can have a negative effect on the reduction and melting of the ore, as it forms a blockage for the hot reducing gases. When the fines reach the cohesive zone and melt, the remaining oxygen is removed by direct reduction. This results in a higher fuel rate or cooling of the furnace. If the material does not melt in due time before reaching the tuyere zone, the “non-molten” material is observable as scabs through the peepsights.

Note that there is a difference between the path travelled by the coarse materials and fines. When the burden descends through the furnace, the fines fill the holes as soon as they are formed, while coarse materials follow the wall. Fines travel more vertically and faster towards the cohesive zone (see Figure 11.2). It is possible to deflect the fines with a bell top arrangement by using the furnace movable armor as a deflector, and with a bell-less top by charging from the outer to the inner position.

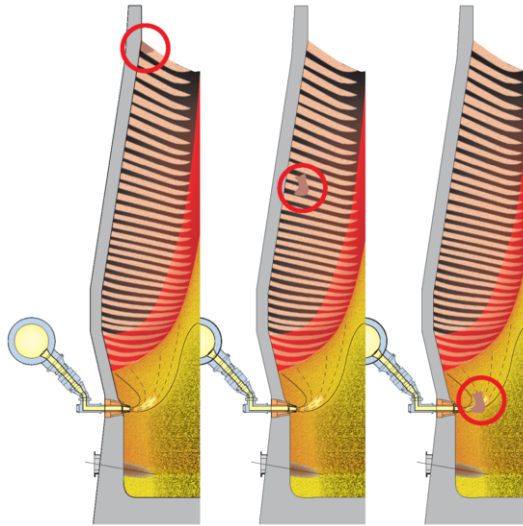

Figure 11.2 Fines charged at wall migrating through the furnace and appearing as 'scabs' in front of tuyeres

Stockhouse management

An additional source of fines that can be avoided through slight modification in stockhouse practices is that of bin management. The bin fill levels may drop if there has been an interruption in the supply of materials. Note that bins are not to be used for logistic optimization; bins have to be full above 80 % all the time to prevent degradation. Nevertheless, occasionally the bin level may have dropped so low as to require a stop of the blast furnace, or supply may have resumed in time for the blast furnace to remain in operation. In either case the refilling of the bins should be managed to avoid excessive breakdown of the material as it falls a longer distance. It may be tempting to try to increase the bin levels at all of the bins by filling them all up gradually. However, this method will result in more material falling from a greater height as the bins will continued to be emptied as they are being refilled. It is preferable to work with fewer bins, so that the levels can be increased more quickly, even though they are being emptied at the same time. Once the bin levels are up at 80 or 90 %, the excess feed material can be diverted to a low-level bin, which remains out-of-service. The fuller bins are then topped-off when they drop to their usual target level of 65 to 70 %, giving some head-room for the supply to be diverted to the less full bins (Figure 11.3 on the next page).

Refilling the bins by this method will reduce the amount of material that has to drop from a greater height, as there will be less transfer time and more filling time, and the bins that are not being used while they are being filled will fill more quickly. Once each bin is back to normal fill levels they should be brought into operation. This will result in each bin coming back into operation one at a time. This staggering of the restart of the bins will avoid the material that has been dropped the furthest distance in each bin being charged to the blast furnace at the same time.

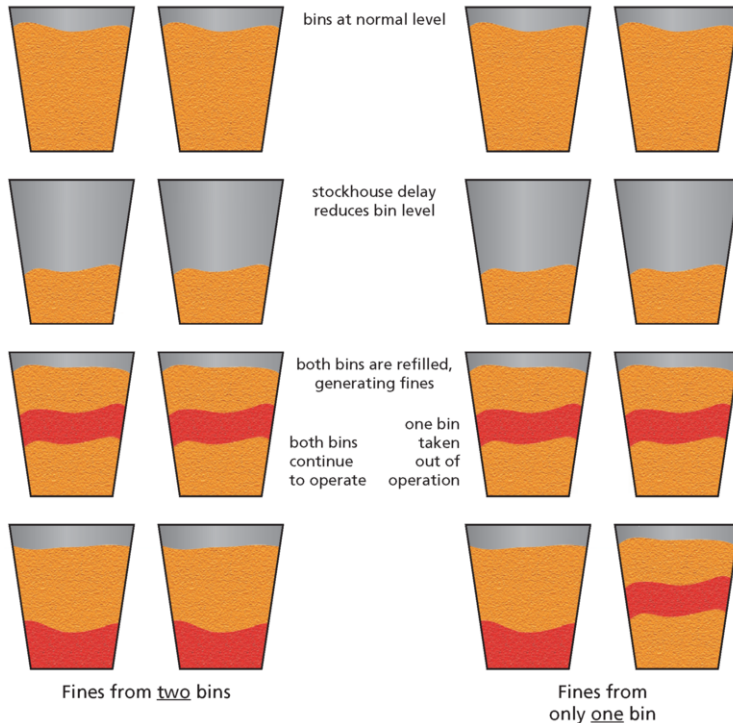

Figure 11.3 Effect of staggered restart on stockhouse bins: by using less bins

11.1.2 Moisture in coke and burden

Moisture input and elimination

The moisture charged into the furnace with the coke and ore burden must be removed before the process can start. This takes place in the upper part of the furnace. The amount of water with the charge at 1 % ore burden moisture and 5 % coke moisture is about 33 kg/tHM of water. The center dries very quickly, but in the wall area it can take much longer – up to 40 minutes, as shown in Figure 11.4.

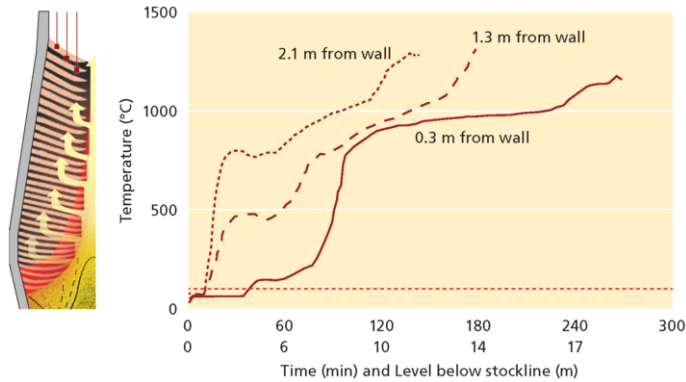

Figure 11.4 Temperatures and height in a blast furnace, the red dotted line indicates “dry” 100 °C

If the moisture input increases, it will take longer for the material to dry, and the isotherm where the reduction process will start will descend downwards. As a consequence, gas reduction will be less efficient. More oxygen will remain bound to iron, and this oxygen has to be removed by direct reduction in the lower part of the furnace. This consumes coke which was not charged and cools the furnace.

Most companies are equipped with moisture gauges for coke bins, so that variation in moisture input in coke is compensated to ensure that the dry coke rate is constant. Note that this is only a minimum correction to maintain the current thermal state. If the furnace is already operating with low top temperature (below 100 °C) the compensation with coke moisture gauges will not be sufficient to compensate for the decreased efficiency of the reduction process.

Where moisture is added in place of coke, the furnace cools and so the normal thermal control procedures will be activated, usually calling for additional fuel. If the moisture level then reduces again, the furnace will warm up, triggering another set of actions. If this is allowed to continue, the furnace will enter a thermal cycle that will in turn consume more fuel than required. Extreme coke moisture variation typically occurs when the coke supply is switched from wharf coke to stockpiled coke that has absorbed more moisture due to rain or a storage field that is not well drained. If coke moisture readings are not correct, it can cause large swings in the thermal state of the furnace. Another cause of major swings in moisture input is the use of water sprays to prevent dust emissions.

This effect is just as important with pellet moisture, especially where pellets have been shipped or stored under damp conditions. They can contain up to 6 % water. When a batch of these pellets is charged to the furnace, the top temperature will decrease with the additional moisture. The furnace will start to warm up due to the fact that a lower amount of iron is being charged to

the furnace with the higher moisture pellets, provided that there is sufficient gas available to eliminate the water. Coke rate changes will normally be made to correct for this warm up. However, once this batch of wet pellets has been consumed it is very important to realize that the furnace will then cool down, due to the additional iron that is being charged with low moisture pellets. If this is not anticipated, the furnace can cool down very quickly, so it is better to anticipate this change by increasing coke rate when it is known that the wet pellets have been consumed and dry pellets are soon to arrive. Some of the larger blast furnaces also have pellet moisture measurement instruments installed on the stockhouse bins.

Ideally, coke and pellet moisture gauges can be installed to monitor and correct for any changes on-line. These moisture gauges take regular readings of the as-charged moisture levels for coke and pellets and will make corrections for the weight, so that the required quantity of the material is charged.

The recommended approach is that the top temperature is not allowed to fall for a prolonged period (8–16 hours) below dew point temperature. Some companies are able to run the top gas temperature at low average levels, well below 100 °C. In these situations, monitoring the temperatures in the wall area (3–5 meters below the burden level) to determine whether or not the burden is dry ‘on time’ is recommended.

Moisture condensation and recirculation

Since burden materials are charged well below the dew point of the moisture in the furnace gas, the moisture in the gas will condense on the colder parts, frequently the cooled staves and freshly charged materials. This applies not only to the moisture which is charged (typically 30–40 kg/tHM), but also to the moisture which is generated in the process. There is more water generated when there is more hydrogen produced from the injectants at the tuyeres. At a coal injection level of 200 kg/tHM and 5 % hydrogen in coal, about 36 kg of water per tonne of hot metal comes from the coal and has to be eliminated with the top gas. The amount of water generated from natural gas is even higher: at an injection level of 80 kg/tHM, about 65 kg water comes from the natural gas. All the water has to be eliminated with the top gas.

If this is not the case, a condensation–evaporation cycle will start. Evaporation will take place more towards the center and lower down in the furnace, while condensation takes place closer to the wall as shown in Figure 11.5. In the course of this cycle, the isotherms where the reduction process starts will descend lower and lower in the wall area of the furnace, reducing the efficiency of the process and creating a risk of tuyere failure and upsets. This situation can be very serious if water starts to flow between the staves and shell downwards. Skulls can be created on the furnace wall, and water has been observed coming from the tuyere seals and even the taphole. Remedial actions have to increase the gas volume per tonne of hot metal, since water is eliminated as a vapor. For instance, extra coal can be injected. Note also, that the water elimination

depends on the top pressure, since at a lower top pressure the top gas can contain more water vapor at the same temperature. Small furnaces with low top pressure are much more forgiving for high water loads than large, high-pressure furnaces.

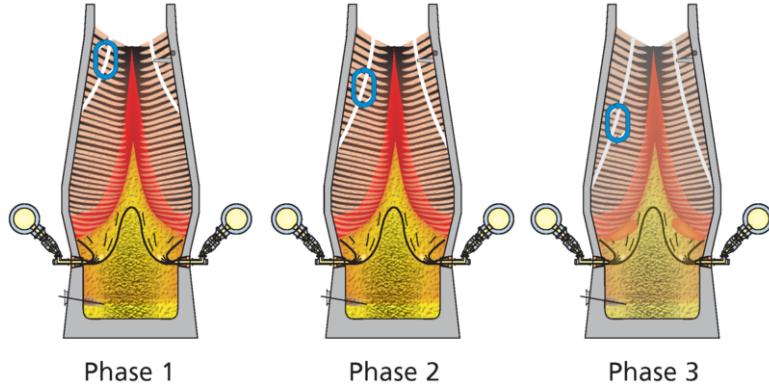

Figure 11.5 Effect of evaporation–condensation cycle of moisture, coming from charged materials and generated in the process. The gas flows from inside out reaching lower temperatures and water will condense. The 100 °C isotherm is indicated in white. The mechanism proceeds as follows:
 Phase 1 – Normal operation
 Phase 2 – When the water input is high, vapor condenses where the gas temperature is below 80 °C; this occurs in the wall area, especially on the freshly charged raw materials. The 100 °C isotherm is driven downwards.
 Phase 3 – As the evaporation–condensation cycle continues, the 100 °C isotherm is driven further and further downwards. The metallurgically active area near the furnace wall becomes smaller and smaller, impeding gas reduction in the periphery. Direct reduction levels increase, the furnace becomes inefficient with low η_{CO} .

11.2 Burden descent

11.2.1 Variability of charging and production rate

Most operators observe the charging rate in a furnace as defined by the amount of charges put into the furnace per hour. If the charging rate increases while tuyere conditions are unaltered, the furnace will fall short of heat. Simply put, with the same amount of heat and gas produced at the tuyeres, more hot metal is made, so the furnace will chill. The reasons for this happening can be various.

- fuel shortage as a consequence of an increase in direct reduction,
- too low coke input for instance by incorrect compensation,
- too high input of ferrous material (e.g. when changing from ‘wet’ pellets to dry pellets),
- by changing process conditions.

Example 11.1 Monitoring drying capacity and remedial actions

The drying capacity of the gas determines how much water can be eliminated from the furnace. How to determine whether or not the burden has become “dry” sufficiently quickly? This can be done by

- Average top temperature, which is a relatively insensitive measurement.
- Skinfow measurements (skinfow are temperatures a few centimeters inside and 1–5 m below the stockline).
- Short in–burden probes. A temperature measurement around 60 cm inside the hot face, around 3 m below the stockline, Figure 11.6.

A statistical analysis has shown that the short in–burden probes are the best tool (Geerdes, 2018).

An operational example is shown in Figure 11.6. Heavy rain caused an increase in moisture input, which caused top temperature and in–burden probe temperatures to decrease. The operator reacted by reducing oxygen enrichment by 2 %, which also resulted in a temporary reduction of production by 7 %. As a consequence of the actions, the process remained stable (η_{CO} , Silicon) and was normalized as soon as the rain stopped.

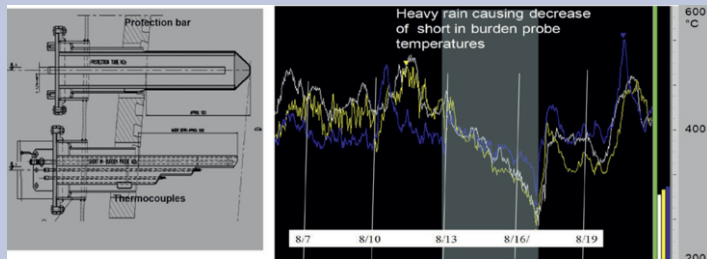

Figure 11.6 Short in–burden probe (left) and monitoring during heavy rain, while operator reduced oxygen enrichment by 2 % in order to keep probe temperatures above 300 °C

Here we refer to increased direct reduction. In some situations, the gas reduction of the burden does not progress sufficiently. This can be caused by

- Too much water input, lowering the isotherms within the furnace and shortening the process height of the furnace, especially at the wall.
- Large amount of fines charged into the furnace resulting in poorer pre–reduction and increased direct reduction.
- Irregular burden descent, causing mixed layers.
- High liquid residual level which affects the normal gas flow through the burden.
- Charging delays causing the newly charged material to see shorter process height and altering burden distribution.

The resultant material with insufficient pre-reduction will in any case continue to descend to the high temperature region above the tuyeres. When this material starts melting, all the oxygen will participate in direct reduction. This consumes coke, makes the furnace descend faster and drives the cohesive zone downwards. This is a self-propagating effect, and when the cohesive zone reaches the tuyere level, it will chill the furnace within hours.

Experienced operators equipped with the right tools can observe the increased direct reduction long before the casthouse gives warning of low hot metal temperature. The method to correct the incident is to bring the cohesive zone back to its previous position. This can be done with extra fuel injection and/or lower blast volume, and by maximizing heat input into the furnace (maximum hot blast temperature and no blast moisture) or, in serious situations, by charging extra coke from the top.

An example of the use of direct reduction as an early warning signal for a cooling trend in the furnace is shown in Chapter VI. The earliest signal of a cooling trend comes from the increase of direct reduction followed some time later by an increase in charging rate. The hot metal silicon reacts a few hours later, because the colder material has to percolate through the hearth.

11.2.2 Hanging and slipping

The burden descent sometimes becomes erratic (see Figure 7.5). What happens in the furnace if it hangs and slips? The mechanism of hanging and slipping is illustrated in Figures 11.7–11.9.

First, the furnace hangs because at the cohesive zone, bridges of melting ore burden are formed. “Bridge formation” is the phenomenon where solid materials can be piled upon each other and will not collapse into a hole: see Figure 11.7 for a bridge formed from marbles.

Second, while the furnace hangs, the process continues: coke is consumed and ore burden melts. Voidage then arises in the active coke zone, which is below the cohesive zone.

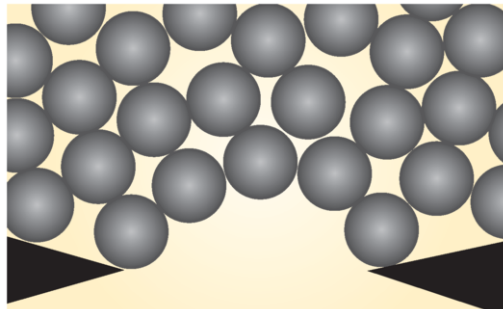

Figure 11.7 Bridge formation illustrated by a theoretical experiment with marbles

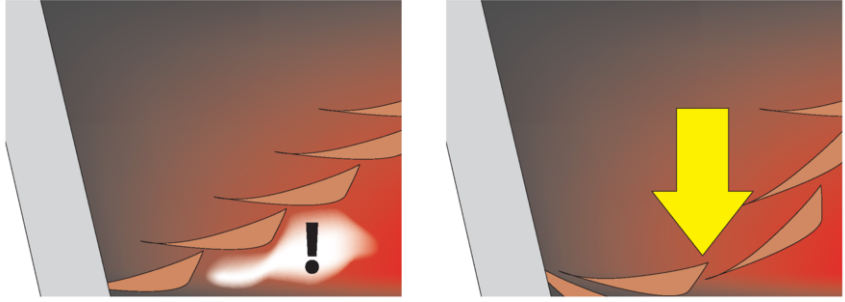

Figure 11.8 Creation of voidage below bridges and consequential collapse

Third, when this voidage becomes too big, it collapses: the furnace burden slips (Figure 11.8). The layer structure is completely disrupted and the gas flow through these layers is impeded. This leads again to areas in the furnace where ore burden is insufficiently reduced and remains in a cohesive state for too long. These areas will form the bridges for the next time the furnace hangs. The problem can only be solved by re-establishing the layer structure within the furnace, which means that the complete content of the furnace has to be refreshed: the furnace has to be operated on reduced blast volume for five to ten hours to prevent a continual cycle of hanging and slipping.

After a slip, the layer structure in the furnace is disrupted, impeding the contact between gas and burden (Figure 11.9). As a consequence, the gas reduction reactions slow down, and extra direct reduction will take place in the hearth: the furnace will chill. The process will recover when a normal layer structure is restored. It takes 6–8 hours to refill the furnace on a decreased wind volume.

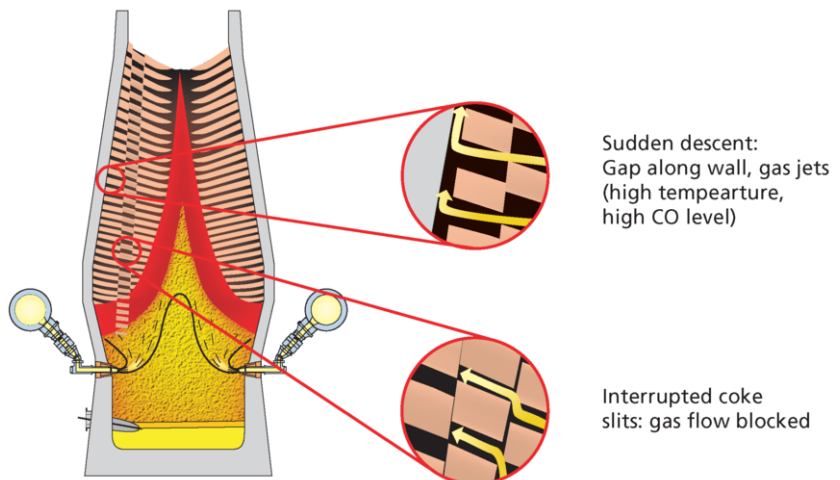

Figure 11.9 Disrupted layer structure and impeded gas flow

11.3 Channeling

Channeling in a blast furnace is a local, preferential gas flow through an area with the lowest gas resistance. Channeling makes a blast furnace less efficient. Channeling is often observable from sudden fast drops in η_{CO} . An example is shown in Figure 11.10, where η_{CO} decreases from 49 % to 36 %. This means that a large percentage of the bosh gas passes through the furnace unused. Channels normally come and go in a few hours. As soon as a channel is formed, the gas finds a preferential path and blast pressure drops as well. Severe channels can lead to drops in η_{CO} of 5–10 % or more, as in the example.

The major impact of channeling is the loss of chemical and physical energy in the gas. As an example, a sustained reduction of 3 % in η_{CO} and increase of 100 °C in top gas temperature was seen to reduce the hot metal temperature by 80 °C. The increase in top temperature is visible in the example as well.

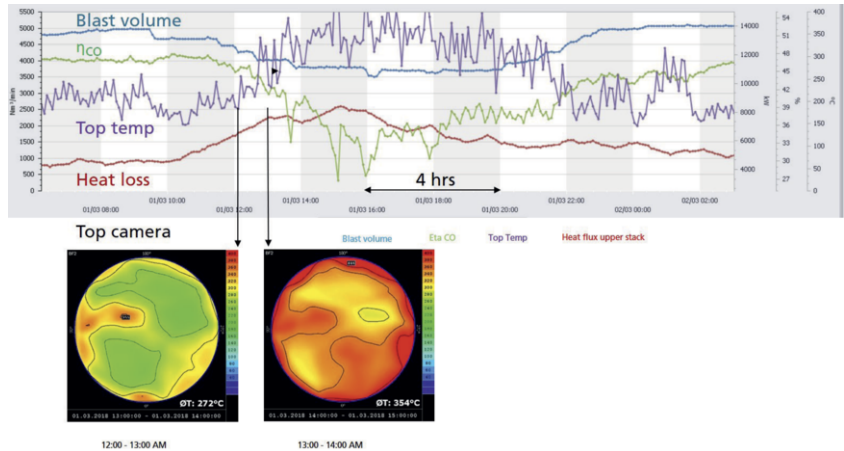

Figure 11.10 Typical example of channeling

Most of the channeling starts along the wall of the furnace. Because of the inverse conical shape of the shaft, a gap is easily formed when burden descends. Channels have a self-enhancing effect: a strong gas flow blows away materials, especially fines, and prevents materials from collapsing in the channel. Gas flows can be so strong that fluidization starts. Gas flow through channels along the wall cause the staves to heat up. This means that channels can also be observed from local heat losses and/or stove temperatures. Pressure taps can show a very small pressure difference at different levels, which can be an indication of a channel.

Channels are caused by the difference in permeability around the circumference and along the radius. Experience shows that channels can be caused by irregular burden descent, since fast descent creates gaps between wall and burden. Irregular burden descent is caused by uneven melting of the cohesive zone.

This can be caused by

- Concentration of fines charged or created by reduction disintegration, since fines create an area with high resistance to gas flow. Channeling frequently coincides with charging stockyard materials.
- Drainage of primary slag because of poor melting. This can be caused by insufficient compensation for direct reduction or a high local basicity.
- Formation of scabs in the cohesive zone in the wall area.
- A special situation is that a charge of 100 % pellets at the wall may cause the pellets to glue together, and this leads to channeling. Lump ore with low melting temperature can behave similarly.
- Unstable burden descent: there are many reasons for unstable burden descent, such as poor casthouse operation and operating the furnace at too-high blast pressure.

Remedial actions for channeling are the following.

- In the very short run an operator will try to cause the channels to collapse. In the first instance by checking the furnace at the end of a cast. Checking may fill the gaps. If the channel reappears after the checks, then the furnace has to be operated on a lower blast volume.
- In the long run, the occurrence of channels has to be prevented by having stable burden descent. Channels can be prevented by using the ideal burden distribution as in Chapter VII. Proper blending is essential as well as preventing the formation of thick, cohesive ferrous layers.

11.4 Recirculation of alkali and zinc

In furnaces operated with a central gas flow, the top gas temperatures in the center increase to such a level that part of the alkalis and all the zinc leaves the furnace as a vapor with the top gas. If top gas temperatures are low, the alkalis and zinc may accumulate in the furnace. The zinc normally condenses on the refractory.

11.4.1 Alkali in the blast furnace

Alkalis, which are sodium and potassium salts, enter the blast furnace with the ferrous burden and coke and coal. The alkalis takes part in a cycle of reduction–oxidation as well as vaporization–condensation.

The alkali input in a blast furnace is typically 1.5–5 kg per tonne of hot metal. In local situations, where companies have access to local ores with relatively high alkali content, the input can reach higher levels. In this situation, high productivity is normally no longer possible, but the competitive edge is gained from the cost advantages of the use of cheap local ore.

From measurements of chilled blast furnaces, it has been observed, that the amount of recirculation is about 3–10 times the input.

Alkalis in the blast furnace have various effects on operation. From a chemical point of view, alkali acts as a catalyst for solution loss ($C + CO_2 \rightarrow 2 CO$). This means that, at high alkali input, the fuel rate is slightly higher. This effect is generally rather small; reported values are 6–11 kg coke per kg alkali in the burden. The additional fuel can be added by increased PCI, leading to more top gas energy from the furnace.

A second effect is, that degradation of coke and ferrous materials is promoted, which leads to poorer permeability and can affect productivity at high production rates.

Moreover, alkali can lead to the formation of scaffolds in the furnace: solid material adhering to the wall in the stack of the furnace. The effect of the formation of scaffolds is that the burden descent deteriorates, in extreme cases leading to hanging and slipping. High levels of alkali have also been observed in scabs, formed from cohesive material in the bosh/belly area.

Finally, the refractory materials, especially the carbon-based refractories, can be attacked by alkali, affecting campaign length. For this reason, alkali control in the furnace and prevention of scaffold formation require attention from the blast furnace operator. Blast furnace operators should monitor alkali and zinc loading and removal to have an idea of the recirculation of these undesirable elements inside the furnace or calculate percent removal.

Sodium and potassium

The two types of alkali, sodium and potassium, behave differently. Sodium is more easily removed from the furnace with slag as well as via the top gas. Moreover, in most furnaces the potassium input is higher than the sodium input. So, for our purposes it is sufficient to observe the potassium balance. Only in situations where the sodium input is higher than the potassium input, do both have to be observed. The alkali leaves the furnace mainly via the slag. Some of the alkali leaves the furnace via the top gas and top gas dust.

Recirculation of alkali is shown in Figure 11.11 on the next page. Alkali entering the furnace as silicates are first dissolved in the primary “melt” formed in the cohesive zone. This melt has a very high level of FeO. As soon as the iron oxides have been reduced out of the primary slag the final slag is formed. As indicated below, the alkali can be reduced to elemental sodium and potassium, which do not dissolve in hot metal or slag. Sodium and potassium are gaseous and ascend with the gas in the furnace. In the high temperature area (around 1400 °C), cyanides are formed that bind with the alkali and ascend with the gas. As soon as the oxygen potential rises, the cyanides are no longer stable and disintegrate to alkali oxide and alkali carbonate (around 1100 °C). The material is absorbed into the solid material (coke and ore burden) and starts descending again with the melting ore burden. The carbonates will dissociate to CO_2 and alkali oxide again. The alkalis recirculate in the area where the ore starts softening (around 1200 °C) to where the slag is free of FeO (1400–1450 °C).

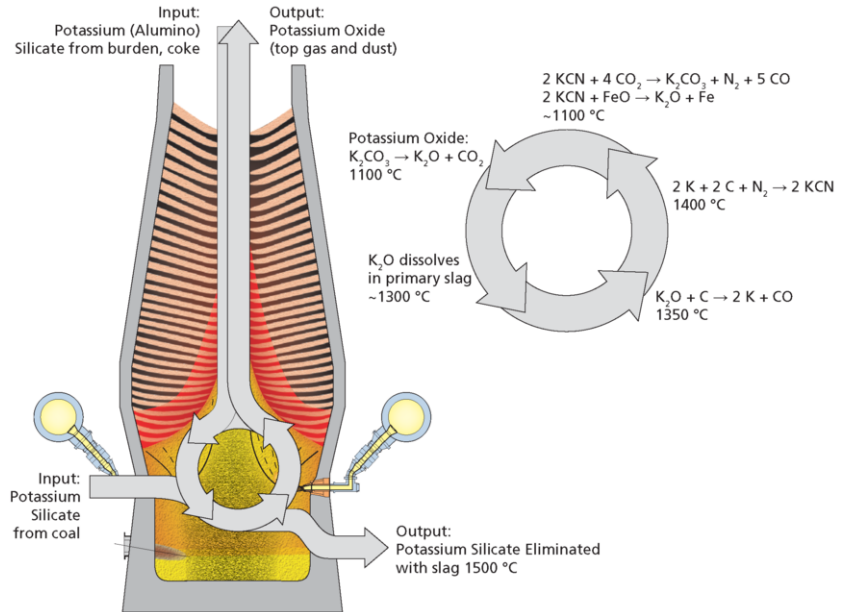

Figure 11.11 Recirculation of potassium (a similar cycle applies to sodium)

The retention of alkali by slag is influenced by the slag basicity, slag composition and the temperature of hot metal and slag. The lower the basicity, the more easily the basic K_2O and Na_2O are removed. The lower the temperature, the better the alkali absorption capacity of the slag.

In operational practice this has interesting consequences. If a blast furnace is stopped, the slag basicity is normally decreased by 10–20 % in order to restart the furnace with a slag with lower liquidus temperatures. After the restart, the slag basicity is often low and the temperature is low. So, analyzing the K_2O in slag before and after a stop, the operator can get an impression of whether or not a high amount of alkalis is circulating in the furnace. The slag composition (especially MgO and MnO content) also affects alkali removal capacity.

Some alkali is removed with top gas. The top gas temperature varies over the diameter of the furnace throat. Furnaces operating with a central gas flow have high temperatures in the center (average > 600 °C). The alkali is removed with the central gas flow. It is generally accepted that operation at high productivity and low coke rate (high PCI rate) requires a central gas flow. This facilitates the elimination of alkalis.

11.4.2 Zinc

Zinc enters the blast furnace via the sinter, mainly through recycling of blast furnace top dust, blast furnace sludge and dust from the secondary dedusting. Interestingly, a relatively large part of the final zinc input comes indirectly from

the type of scrap the steel plant is using, especially scrap from galvanized steel. Zinc enters the furnace as an oxide, silicate or ferrite. It is reduced in the lower part of the furnace to elemental zinc. Since it has low melting and boiling points (419 and 907 °C), it ascends through the furnace as a vapor and is then reoxidized by CO₂, condenses to burden and coke and participates in a similar recirculation pattern as potassium. Zinc is eliminated from the furnace with the dust from the top gas, especially from the gas at the furnace center. Zinc adheres to the surface of particles. As a consequence, the finer the particles, the higher the zinc content. This means that zinc can be recaptured by segregating the fine fractions in the wet sludge. The fines can be upgraded to higher zinc concentrations in a specialized blast furnace or a rotary hearth furnace.

Zinc oxide can condense on the furnace walls and on/in the coke lumps. Zinc can form scaffolds in the furnace, thus leading to deteriorating operational results. Occasionally the scaffolds melt when a tuyere is changed and liquid metal (zinc) drops from above. When zinc is deposited in the pores of the ferrous materials, it can impede the gas reduction, leading to higher reductant rates. Zinc also deposits in carbon-based refractories causing them to become brittle and crack, which reduces lining life. Zinc control is mostly done by controlling input levels. Typically, 100–200 g/tHM is used, but higher values for specialized operations are also known.

11.5 Adherences to the furnace wall

Solid material can adhere to the furnace wall. Scaffolds consist of materials that adhere to the wall, while scabs are materials that are not yet completely molten. Different locations for adherences are shown in Figure 11.12.



Figure 11.12 Positions of scaffolds in blast furnaces (photograph shows upper furnace)

Scaffolds in the upper part are often caused by high alkali loading, high zinc loading, high fines input and low top temperatures. A number of companies have experienced high alkali input due to their local raw material supply.

Methods have been developed to control the amount of circulating alkali in the furnace by various methods, like coke charging at the wall, cleaning operations at low basicity and/or low burden level. A company operating at alkali levels up to 4.5 kg/tHM (2–2.5 kg K_2O /tHM) controls scaffold formation by:

- Eliminating as much fines as possible from the burden. In doing so the chance on scaffold formation becomes very much lower.
- Cleaning action. As soon as indications of scaffold formation are manifest from the unstable burden descent and high pressure, a cleaning action is carried out. This cleaning action consists of lowering the burden level to 14–15 m above the tuyeres (9 m below stockline), while keeping the top temperature under control with water sprays. During the period of low burden level, the scaffolds will fall into the furnace and the normal operational conditions are restored as soon as the burden level has been restored.

Scaffolds in the lower part of the furnace in the bosh/belly area are re-solidified slag. The scaffolds have a strong effect on burden descent as can be understood from Figure 11.13. Since the scaffolds tend to grow, operation deteriorates.

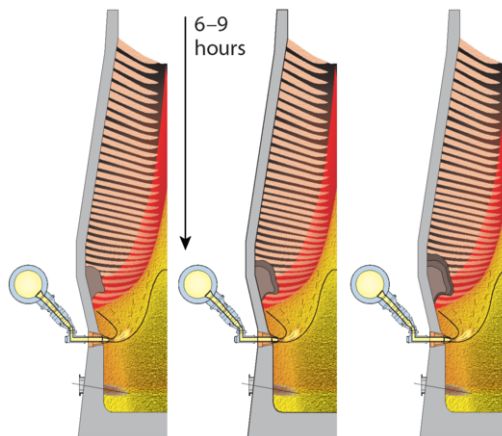

Figure 11.13 Scaffolds in lower part of the furnace

This type of scaffold can only be melted away. In a typical example, in total 20 % of the working volume was charged as coke blanks in three batches on successive days, while the basicity was decreased by 20 %. After that, the scaffold disappeared.

11.6 Tuyere blockage

With coal injection it is very important that the tuyeres are clear and open, allowing the coal plume to flow into the raceway to optimize combustion. If the tuyere should become blocked, or a blockage in front of the tuyere occurs, the coal must be removed immediately. If it is not, then the coal will be forced backwards into the tuyere stock and can ignite further up in the connection

with the bustle pipe (see Figure 5.9). This can cause serious damage or even explosions. It happens especially within an hour of the restart of a furnace, since unmolten material blocks the tuyere gas flow. The phenomenon has also been observed with natural gas injection. In many cases this has been a cause of a chilled hearth since the furnace is shut down in an unprepared state for extended periods to replace tuyere stock or repair the bustle main.

To prevent an incident, a light sensor may be fitted in front of the peepsight to detect a blockage at the end of the tuyere, or the ΔP can be measured over the tuyere stock to detect gas flow into the furnace, if there is no flow, this indicates that a blockage is present. The coal to that tuyere is automatically switched off and restarted only once an operator has checked tuyere condition. Many furnaces using natural gas injection rates over 90 kg/tHM are also installing the ΔP blocked tuyere detection to shut off the natural gas to prevent back-ups. Tuyere cameras allow the operator to monitor blockage from the control room.

11.7 Tuyeres: failures and water leakage

The tuyeres are a critical part of furnace equipment, but what can be observed when walking around the tuyere platform? What can happen to the tuyeres? There are two types of tuyere – single and double chamber. The single-chamber tuyeres have one cooling channel, whereas the double-chamber tuyeres have a separate nose cooling pipe and a body cooling pipe. The advantage of the double-chamber tuyeres is that the body can continue to be cooled after the nose has been burnt, and changing the tuyere can wait to the next planned furnace stop. If a body cooling circuit in a 2-chamber tuyere or the water circuit in a single-chamber tuyere is burned, a furnace stop is required immediately to change the tuyere to prevent large quantities of water from entering the furnace hearth resulting in furnace cooling.

11.7.1 Water Discipline

A duller light in front of the tuyere can be an indication that water is present at or around the tuyere. This water could be coming from the tuyere itself, the tuyere next to it, or a cooler in the region above the tuyere.

Other signs to look out for when water is suspected are:

- Water visible under tuyeres, at grouting nipples or at thermocouple sockets
- Top gas hydrogen increase. However, when hydrogen in the top gas indicates water leakage, there is a very large water flow going into the furnace.
- Smell of ammonia
- Unusual thermocouple activity
- Increase of make-up water frequency in closed cooling systems
- CO gas detected at outlet of open water system
- Cooling furnace trend, less reaction to additional fuel than expected
- Water flame at taphole, a yellow or orange flame instead of a blue flame
- Short or spitting tapholes

When water is suspected it is very important to locate and isolate the source as quickly as possible to limit the quantity of water entering the furnace. Depending on the location of the leak, a furnace stop may be required to find and isolate the leak.

Water inside the furnace is extremely damaging to both the process and the equipment, and the consequences of allowing leakage to continue are extremely serious for both. The major consequences are:

- Attack of refractories in the hearth and/or the taphole.
- Local heat shortage in the process leading to inefficient process, scabs, more burnt tuyeres and an increased requirement for reductant/fuel.

11.7.2 Burnt Tuyeres

The ideal scenario is to change tuyeres because the working lifetime has been reached, or will be passed before the next furnace stop. This preventative changing of tuyeres is usually done with a target lifetime of two years for double chambered tuyeres. However, many companies need to change their tuyeres much more frequently than this, with a tuyere lifetime of less than 6 months considered to be poor. Other than preventative changing, the most frequent reason for changing tuyeres is burning (Figure 11.14). As the tuyere coolers are made of copper, which has a melting temperature of 1083 °C, water cooling is absolutely essential to protect the tuyeres, and even then they may not be protected against a direct 'strike' with hot iron.

Burnt tuyeres may occur due to a number of different mechanisms, these being:

- Hot metal attack by low position of root cohesive zone. In order to prevent this a protective layer is sometimes made on the upper part of the tuyere.
- High hearth liquid levels
- Tuyere condition: inadequate cooling or casting defects during production of the tuyeres
- Presence of aggressive chemical compounds in the blast furnace, primarily compounds containing chlorine.

Sometimes tuyeres are damaged and start leaking if the coal lance is not maintained in the center of the blast flow, and a situation is permitted where the coal causes erosion of the copper all the way through to the cooling channel.

For tuyere burning by the process 2 different mechanisms are suggested.

1. Tuyere burning at the lower side and nose. This is caused by attack from circulating coke and sometimes as well by poor drainage of liquid from the raceway to the hearth. Poor drainage can be caused by coke fines and a high Al_2O_3 slag coming from the coke and coal ash (Figure 11.14a).
2. Tuyere burning from the top: hot metal drips down onto the tuyere, causing local high heat flux so that the cooling water starts boiling, which jeopardizes heat transfer. Typically, sharp holes "bullet holes" are formed (Figure 11.14b). If these occurring at frequent intervals, charging more coke at the wall to raise the cohesive zone can often be successful.

In general: tuyere burning is caused by local poor melting of the ferrous burden. Methods to prevent it are mentioned throughout the book, an adequate primary slag basicity is of prime importance (see Chapter VIII).

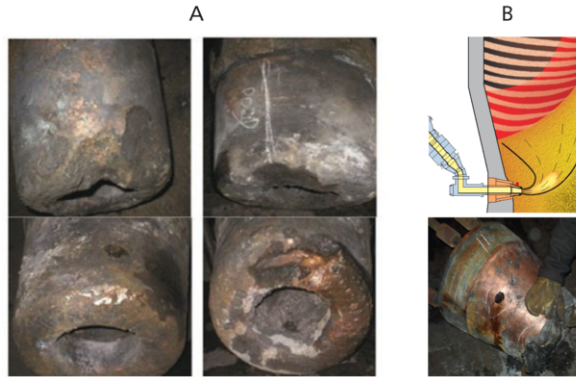

Figure 11.14 Tuyere failures: Wear at the nose (A) and “Bullet holes” (B)
(A. Yaniga and Francis, 2010)

11.7.3 Tipped Tuyeres

Tipped or dipped tuyeres can be identified by seeing an oval shape rather than a round orifice when looking through the peepsight. There may also be gas blowing between the tuyere and cooler seat. In the more extreme cases, the outlet of the tuyere will be completely obscured. This is thought to occur when material from above impacts on the tuyere, forcing it downwards as shown in Figure 11.15. It is also an indication of little support being in place below the tuyere, to prevent the downward movement. This can either be due to the design or to wear in the tuyere band. The major cause of tipping is that there is a big scab of solid burden material resting on the tuyere, which is normally caused by too low coke percentages at the wall in the throat.

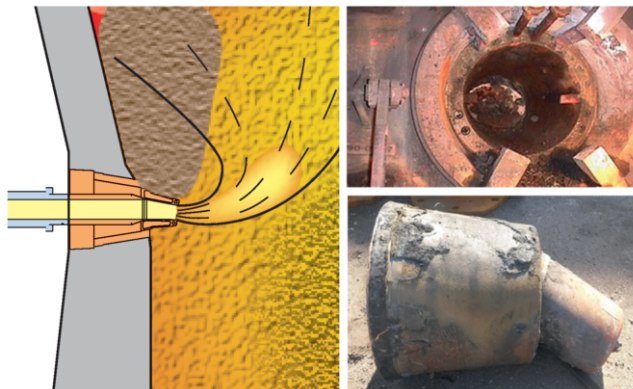

Figure 11.15 Tuyere tipping mechanism (left) and result (right) – upper: tuyere completely drawn into furnace

11.6.4 Scabs in Front of Tuyeres

It is sometimes reported by the blast furnace operator that scabs are seen dropping in front of tuyeres. This has long been accounted for as scabs peeling off from further up the furnace, which may well have been true in the days of high alkali input to the furnace, but this explanation is less acceptable now that burden quality has improved.

A more likely explanation is that it is non-molten burden, which was charged a few hours earlier. There can be several reasons why the burden did not melt in time: late warming up (caused by low burden level at the time of charging, or by poor gas permeability caused by lot of fines or by high moisture content), a very cold furnace (low root of cohesive zone, leading to positioning the cohesive zone almost on top of the tuyeres), too fast coke usage (when a tuyere has no injectant).

11.6.5 Blowpipe failures

With coal injection it is very important that the tuyeres are clear and open, allowing the coal plume to flow into the raceway. If the tuyere should become blocked, or a blockage in front of the tuyere appears, then the coal must be removed immediately. If it is not, the coal will be forced backwards into the tuyere stock and can ignite further up in the connection with the bustle pipe (see Figure 11.13). This can cause serious damage (Figure 11.16).

The blowpipe can also fail as soon as liquid iron enters it or when the coal lance breaks. The damage is caused by the hot gas and coke escaping through a hole in the blowpipe mantle. These situations may cause extreme collateral damage outside the furnace on the tuyere platform, such as melting wiring, piping and instrumentation, or even the blast furnace shell.



Figure 11.16 Failed blowpipe

11.8 Stops and starts

11.8.1 Internal state of furnace

When a blast furnace in full operation is stopped, some processes continue. While the blast is stopped, the direct reduction reactions within the furnace continue as well as heat losses to the wall. As a consequence, the temperature of the material in the melting zone is reduced to around 1000 °C, where the carbon solution loss reaction starts. The decreasing temperature re-solidifies the melting materials. This means that after a stop, it takes some time for the burden to start descending. The burden descent restarts as soon as the “old” melting zone is once again molten (Figure 11.17).

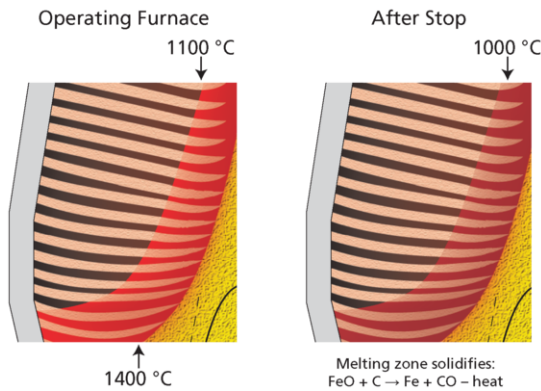

Figure 11.17 Solidified cohesive zone as consequence of a stop

The heat shortage for a stop of a furnace operating with PCI is even worse: during the stop procedure coal injection into the furnace is switched, and during the start-up it takes time to restart the PCI. An additional reductant or fuel shortage results. In addition, after a stop the hot metal silicon sometimes rises to very high values, especially if during the stop/start procedure the furnace is operated at a low blast volume. As shown in Figure 8.17, the basicity of the slag will be affected by the high hot metal silicon and might even solidify within the furnace. This results in disturbed burden descent. Heating up the slag is the only solution, which can be achieved by charging extra coke into the furnace 6–8 hours prior to the stop.

So, in order to compensate for the heat losses during a stop and the risk for high hot metal silicon, the following measures have to be applied:

- Extra reductant into the furnace. Coke, as well as auxiliary reductants, are possible compensations for these heat losses. Additional reductant is needed for the period when the furnace is not operated on PCI.
- Design slag composition for low basicity at high hot metal silicon. Use of a siliceous lump ore is recommended to reduce the slag basicity. Even if a stop is unplanned, taking these measures after the stop is worthwhile, since the cohesive zone will be lifted as soon as the extra coke is processed.

For a blow-in or start-up after a stop, major pitfalls are:

- Too fast blow-in. The solidified melting zone will take time to melt during the start-up. If the time allowed is insufficient, the pressure difference over the burden can increase too much, leading to gas escaping along the wall (high heat losses) and poor burden descent.
- Too fast restart of the PCI. Since the melting zone is solidified, there is a risk that solid agglomerates will block the hot blast through the tuyere. If this happens, the coal will still be blown into the blowpipe where it can cause blowpipe failure. Restarting coal injection only after the burden starts descending is recommended.
- Too high slag basicity.

11.8.2 Stopping a blast furnace

Stopping a blast furnace means that the hot blast is removed from the furnace. Since the furnace is connected to a gas flow from stoves via the furnace to the gas cleaning system, a stepwise approach is required. The objective of the stepwise approach is that there is no chance that an explosive gas-air mixture is formed or that slag enters the tuyeres. To this end, the blast furnace has to be kept on slight overpressure during the stopping procedure.

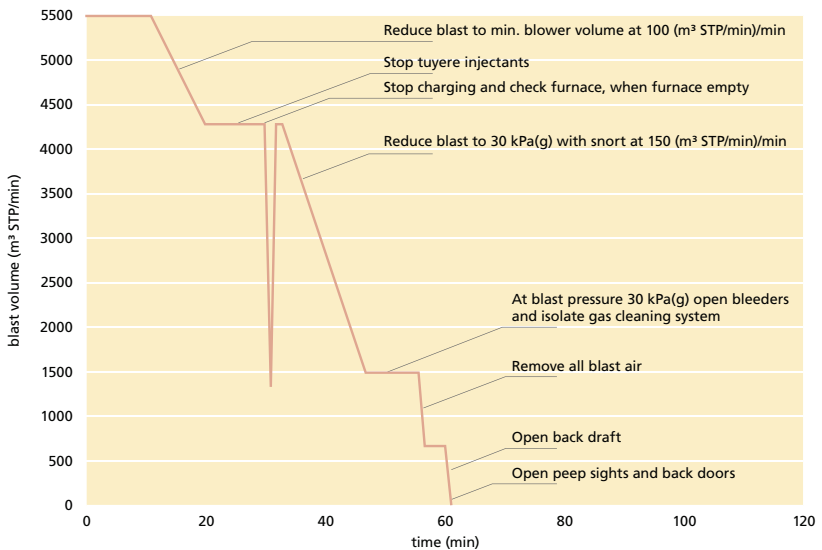

Figure 11.18 Guideline shutdown procedure of a large blast furnace

Step 1 Furnace stopping procedure starts when the furnace hearth is empty. Then blast volume is reduced, a check may be carried out, and the blast pressure is reduced to a low level of 30 kPa.

Step 2 Top gas bleeder(s) are opened and the furnace is disconnected from the gas cleaning system via a goggle valve or water seal – all blast furnace gases are emitted into the atmosphere. The furnace still has at least one taphole open.

Step 3 Blast volume is reduced to zero, and the backdraft stack is opened in order to burn gas from the furnace. The tuyeres may be clayed to prevent air ingress and consequential coke burning during the stop. Some backdoors or peepsights are open to allow for some air ingress into the bustle main.

11.8.3 Start with all tuyeres

After a stop shorter than 5–7 days, medium to large blast furnace can start-up with all tuyeres, provided the stop was well prepared. During a blow-in, the reverse process takes place:

Step 1 Furnace is put on low blast pressure.

Step 2 Furnace is connected to gas grid and bleeders are closed.

Step 3 Hot blast volume and pressure are increased stepwise.

Note, that it takes time for the burden to start descending after a stop and that coal injection should only be restarted after descent has begun.

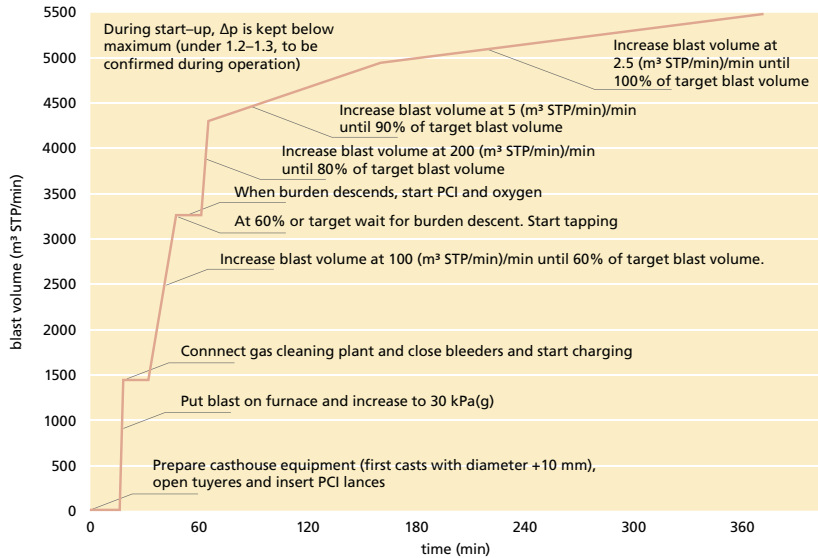

Figure 11.19 Guideline for restart with all tuyeres for a large blast furnace

11.8.4 Blow-down

Blowing down a blast furnace requires operating the furnace without simultaneous charging of the furnace. All the material charged into the furnace is then exposed to the same temperatures and reduction processes, as if the furnace were fully charged.

However, since the temperature of the shaft gas is not transferred to the cold charge, the off-gas temperature increases, and the gas composition changes. Since the equipment has not been designed to withstand the high top gas temperatures, the top gas temperatures are kept under control by spraying water.

The water sprayed above the burden should be prevented from reaching the burden surface, either directly via descent on top of the burden, or indirectly via the wall. Special water atomizing nozzles are required. The success of the blow-down depends heavily on proper spraying. The progress of the blow-down process can be measured from the burden level, as well as from the analysis of the top gas composition. Since less and less oxygen is removed from the ore, the CO_2 percentage decreases and the CO percentage increases (Figure 11.20).

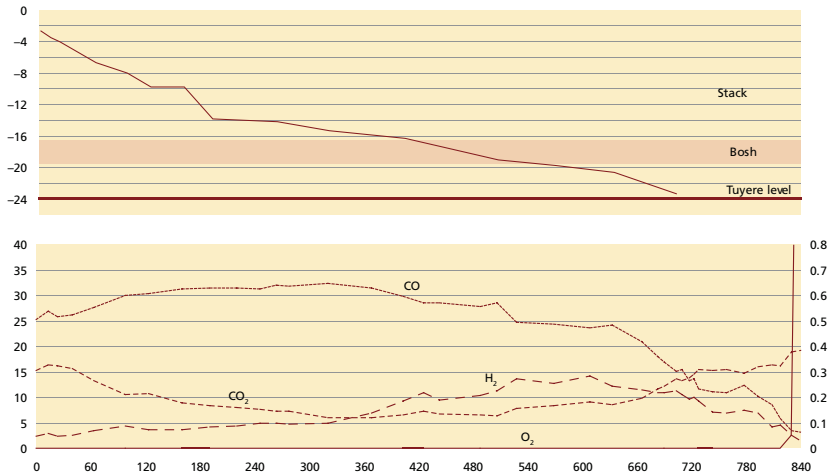

Figure 11.20 Typical progress of a blow-down

Moreover, generally H_2 levels increase as a consequence of the (unavoidable) contact of spraying water with the hot coke. At the end of the blow-down, when the level of the coke approaches the tuyeres, the CO_2 formed at the tuyeres has insufficient opportunity to be transformed to CO , and the CO_2 percentage in the top gas increases. As soon as half of the oxygen is in CO_2 (i.e. when the CO_2 percentage equals half the CO percentage), the furnace should be isolated from the gas system. Normally, a blow-down takes 10 to 12 hours, after a preparatory stop, to reach the tuyere level.

Prior to the blow-down the furnace contains coke in the active coke zone and deadman, and alternating layers of coke and ore in the melting zone and stack. Since during the blowdown, the coke in the active coke zone and the deadman will be gasified, there is coke excess in the blast furnace. During the latter stages of the blowdown reduction reactions have largely stopped, so any auxiliary reductant injection can be stopped during the early stages of the blowdown. The moment is indicated by the gas analysis: as soon as the CO_2 percentage starts to decrease to below 10 %, there is little iron oxide left to reduce.

The burden level in the furnace is difficult to measure with standard stock rods. Mechanical stock rods have to be equipped with chain or cable extensions and recalibrated for the purpose. The stock rods should be used only at intervals, since the high temperatures above the burden may cause chain breakage.

Radar level indicators can be used if reliable. Indications from the level of the burden can also be obtained from:

- The pressure taps.
- The casthouse operation i.e. the quantity of iron cast.
- Calculation of the amount of coke consumed in front of the tuyeres.

Another indication that the blow-down is complete is the collapse of the raceway (no more coke rotating) and detection of oxygen in the top gas. This is caused by some of the blast going directly to the furnace top, since there is no longer a full quantity of coke in front of the tuyeres.

The required condition of the furnace after the blow-down depends on the purpose of the blow-down and consequent repair. Generally, the walls have to be clean. Cleaning of the hearth is another important topic. If solid skulls and scabs are expected in the hearth and have to be removed prior to the blow-down, the furnace can be operated for a prolonged period on a high thermal level, relatively low PCI rate, increasing hot metal manganese, increase of central coke charging and a burden without titanium addition. The full effect of these measures is uncertain, but hearth bottom thermocouples can indicate that there is more activity and less of a skull in the hearth. Eliminating nut coke for a week or two before the shutdown can also be considered.

11.8.5 Blow-in from new or after reline

Blowing in a furnace from new can be considered in two phases:

Phase 1 Heating up the hearth.

Phase 2 Starting the reduction reactions and iron production.

The heat requirement in the early stages of the blow-in is for the following:

- Heat coke in the hearth, deadman and active coke zone to 1500 °C.
- Heat required for evaporation of moisture from the coke.
- Heat required to compensate for moisture in blast dissociating into hydrogen ($\text{H}_2\text{O} + \text{C} \rightarrow \text{CO} + \text{H}_2$).
- Heat to compensate for loss of heat through the furnace wall.

Many operators have learned from past experience that a coke blank ranging from 50 to 65 % of the working volume or coke blank elevation of 11 meters above the tuyere fulfils these heat requirements.

- In the early stages of a blow-in, blast temperature should be maximized and blast moisture minimized.
- Heating up the hearth requires some 7 to 8 hours after the blow-in. Heat is generated from coke used at the tuyeres.

Starting the reduction processes

During the early stages of the blow-in while the hearth is heating-up, reduction of the iron oxides has not yet begun due to the temperatures being too low. For this reason, the increased amount of direct reduction has to be considered. The situation may become difficult if the level of direct reduction is too high, (and gas reduction is low). This situation manifests itself from:

- The gas utilization.
- The direct reduction, as shown by $\text{CO} + \text{CO}_2$ exceeds “normal” values.

The gas utilization is an indication of the amount of gas reduction taking place, while the total CO and CO_2 percentage is an indication for the direct reduction. The CO_2 percentage in particular indicates if gas reduction is taking place.

Slag formation

In general, the slag during blow-in has to be designed for high hot metal silicon. However, with the proposed method the hot metal silicon should be under control. If we continue to follow the “two-phase” blow-in approach mentioned here, during the first phase of the blow-in about 350 tonne coke is gasified in 8 hours and the slag formed comes only from the coke ash. Taking 10 % ash and 30 % of the ash as Al_2O_3 , we get 35 tonnes of high Al_2O_3 slag during the first 8 hours. This will not cause a problem in the furnace because of the small volume. The coke ash can be fluxed with material containing lime.

Hot metal quality during blow-in

As soon as the hearth is heated the hot metal temperature exceeds 1400 °C. As soon as the top temperature exceeds dew-point, all excess moisture has been removed from the furnace and the process has started. Only limited heat is required for heating-up and drying the refractories, if compared with the heat requirements of the process itself. So, as soon as hot metal temperature reaches 1400 °C and top temperature exceeds 90 °C, the process has to be brought back to normal operation conditions.

However, in this situation the coke rate in the furnace is still very high and the hot metal silicon will rise to 4–5 %. The hot metal silicon can be reduced by putting a normal coke rate into the furnace. The “normal” coke rate at “all coke” operation is about 530 kg/tHM. A considerable period is needed here to consume all the excess coke present in the furnace. More rapid decrease of hot metal silicon can be reached if a lower coke rate is charged and auxiliary injection is used as soon as required. The injectant is switched on as soon as the hot metal silicon decreases below 1 %.

Example 11.2 Rapid Blow-in

An example of a rapid blow-in of a furnace with a filled hearth is presented in Figure 11.21. Initially, the furnace was started up with four tuyeres (of 25). After opening all tuyeres, a “heavy” burden (coke rate 440 kg/tHM) was put in the furnace 30 hours after the blow-in and coal was injected into the furnace 40 hours after the blow-in. Hot metal silicon reached the 1.1 % mark 44 hours after the blow-in.

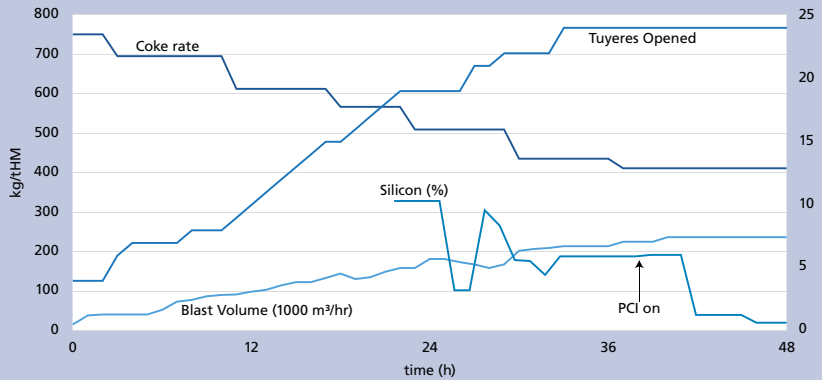

Figure 11.21 Blow-in of a blast furnace in November 2013: Coke rate charged, blast volume, number of tuyeres open and hot metal silicon

11.9 Casthouse challenges

11.9.1 Chills, loss of connection

A chilled hearth is a situation where the connection between tuyere and taphole is lost. Liquids generated above the tuyeres can no longer drain to the hearth and in most cases all tuyeres are filled with slag/melting materials. Sometimes a catastrophic failure of blowpipe or tuyere stock was the reason to finally stop the furnace. The furnace is filled with (semi) solid materials well above tuyere level, see Figure 11.22.

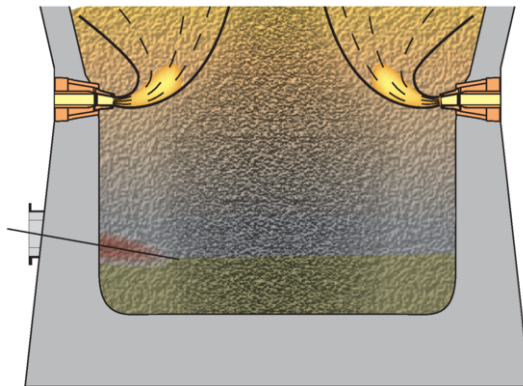

Figure 11.22 Loss of connection of liquid flow to taphole

What are the possible causes?

- Poor burden descent/ slips, hanging:
 - Gunnite or shotcrete falling off the walls
 - Scabs falling off the walls
- Gas–reduction of burden deteriorated
 - As a consequence of disturbed gas flow
 - As a consequence of casting delays, especially if connection is lost after long stops.
- High water input in lower part of furnace
 - Burned tuyeres
 - Leaking tuyeres, staves, cooling plates, hot blast valves
 - Water input with burden materials
 - Top sprays leaking through the shutoff valves
 - Increased heat loss. Burden distribution, loss of refractory protection of staves
- Casting problems
 - Burden quality
 - Improper charging. Burden materials or burden distribution.
 - Loss of fuel injection.

How to recover?

Since the liquids in the furnace have been frozen, the following line of action has to take place:

1. heat has to be brought into the furnace
2. the material in the furnace has to melt as easily as possible and
3. the molten material has to be taken from the furnace.

So, the recovery principle is:

- bring maximum heat into the furnace: note that the tuyeres are the motor of the melting process.
- make slag as liquid as possible: very lean (typically a B2 basicity of 0.8–0.9).
- cast and clean to drain liquids from the furnace.

Step 1 is re-establishing the connection between tuyere and taphole. This can be done with or without oxy–fuel lances (Figure 11.23). The connection is re-established by starting at a few tuyeres above one taphole. We recommend at least three tuyeres, since the tuyeres on the outside lose a lot of heat to laterally to the adjacent tuyere areas that are not working,

Step 2 is to bring sufficient fuel to the tuyeres, so that the liquids draining to the hearth are hot. This can be done by charging coke blanks. Note that a too–high fuel rate only leads to burning coke but no hot metal reaching the hearth.

Step 3 is normalizing the process by placing more and more tuyeres in operation and normalizing fuel rate and process settings.

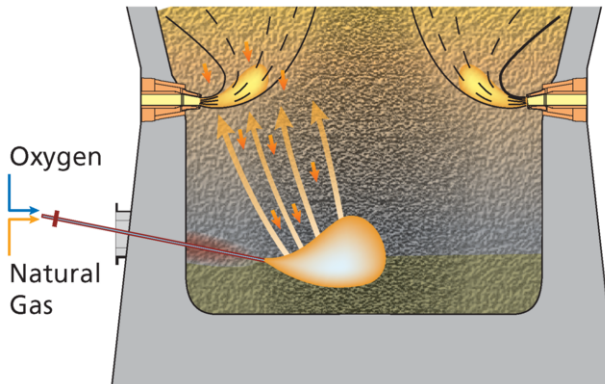

Figure 11.23 Oxyfuel lances mounted in a taphole can establish taphole–tuyere connection with oxygen and natural gas.

11.9.2 Coke mess

Coke mess is a situation where a lot of coke comes out of the taphole. This can happen when the taphole allows the coke through: it is normally rather short and wide and can be caused by the fact, that a taphole was out of operation for a long time, by poor-quality clay, or by water leakage. The coke quality also plays a role: the poorer the coke quality, the easier coke mess can result. The operational reaction is to lower the wind volume, plug the taphole as soon as possible, and start carefully anew. If water leakage plays a role, the problem has to be addressed first before the next cast. The problem can also occur with a new taphole or poor-quality clay which wears too rapidly.

11.10 Greenhouse gas emissions

The amount of carbon we put into the furnace for normal operation is the carbon present in 300 kg coke and 200 kg coal (Table 11.1). If we assume that this carbon is emitted as CO₂, then the emission of CO₂ is 1533 kg/tHM. This is a simplification of reality, since carbon is used for sinter making, coke making, blast generation and the electric power used for the blast furnace operation, nor are credits for top gas taken into account. The European Commission has made a study of CO₂ emissions in the steel industry (Pardo et al, 2012). This study comes to a total CO₂ emission of 1279 kg/tHM. According to Worldsteel, the energy intensity of steelmaking is 20 GJ/tonne, with an average CO₂ footprint per tonne of steel of 1.8 tonne, where for the integrated steelmaking route, the hot metal from the blast furnace accounts for 70 % of the CO₂ output.

Since a blast furnace is operated close to the thermodynamic limitations, greenhouse gas emission reductions coming from increased efficiency will be relatively small. Table 11.1 shows the example of replacing 54 kg coal injection with 50 kg gas injection. This reduces CO₂ emissions by about 2 %. The “best” way to reduce greenhouse gas emission from the BF–BOF route is to use high coal injection rates, thus minimizing coke oven emissions, and to make efficient use of top gas. When further CO₂ reduction is required, the use of pellets will further reduce carbon consumption in the sinter making process.

		Scenario		
		Carbon content (%)	Coal injection (kg/tHM)	Co-injection (kg/tHM)
coke		87.0	300	300
coal		80.0	200	146
natural gas		72.0	0	50
carbon input	kg C/tHM		421	414
CO ₂ emission	kg CO ₂ /tHM		1544	1517

Table 11.1 CO₂ footprint assuming that all carbon input is converted to CO₂

Charging metallic, like HBI and scrap, takes out carbon for reduction and leaves only coke demand for melting these metallics into hot metal. Hydrogen content can be increased through the co-injection of natural gas, increased blast moisture or even hydrogen enrichment.

However, all the above methods will be limited once the minimum top gas temperature is achieved, as shown in Chapter V, and further carbon reduction is not feasible. A carbon-free ironmaking process needs to be separated into a reduction step (i.e. direct reduction shaft or fines-based reduction) and a melting step (i.e. Electric Arc Furnace).

It is the blast furnace operator's responsibility to lower the carbon rate as much as possible. In order to do this, the route from coal and ore to steel has to be evaluated. In many companies the efficiency of the blast furnace is reported in total fuel rate and the operator tries to reach as low total fuel rate as possible. Total fuel rate is often defined as the sum of coke, nut coke and coal. This leads to a penalty in total fuel rate at higher PCI, since coal replaces coke typically by 0.8–0.9 kg coke per kg coal. The consequence is that in many plants, coke rates are well above proven best practice levels. Especially in South-East Asia there are many modern, well-operated blast furnaces with good quality raw materials. A few of these reach coke rates well below 300 kg/tHM as an annual average, while in other parts of the world these low coke rates have already been standard operation for more than 10–20 years.

Management should judge total fuel rate of a blast furnace on the basis of standardized coke equivalents, so that proper replacement ratios can be taken into account. And for CO₂ generated per tonne of hot metal the CO₂ of coke making has to be considered as well.

This page intentionally left blank

Annex I *Blast Furnace Instrumentation*

Instrumentation overview

Modern blast furnace operation can be controlled only by using a wide range of instrumentation. A multitude of temperature, flow and pressure measurements are installed in a modern blast furnace. A few of the instruments are discussed in the present section. An overview of blast furnace instrumentation as discussed in various parts of the text is given in Figure A1.1.

Recent developments are:

- Two-dimensional temperature measurement on burden surface as measured with acoustic signals.
- Thermal image camera above the stockline.
- Tuyere cameras.
- Hot metal and slag flow.

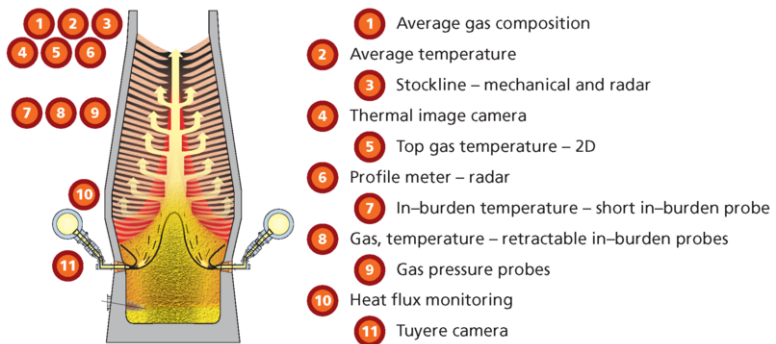

Figure A1.1 Overview blast furnace instrumentation

Radial gas temperature above stockline

Traditionally, the gas temperature distribution in the blast furnace top is measured at multiple points over one radius or several radii. The “SOMA” system is based on a measuring principle that the speed of an acoustic signal depends on gas temperature. By having 8 (or 10 for a large blast furnace) transmitter/receiver units installed around the circumference above the stockline, the SOMA system provides a gas temperature “map” over the entire burden surface. It can also calculate radial temperature profiles.

Figure A1.2 compares single day average temperatures as measured with cross probes and the SOMA system. The SOMA data have been derived for the same radius as the cross probes. SOMA gives lower central temperatures in the example, but the major advantage is that the stockline is not disturbed by the “shadow” of the cross probes when material is charged into the furnace.

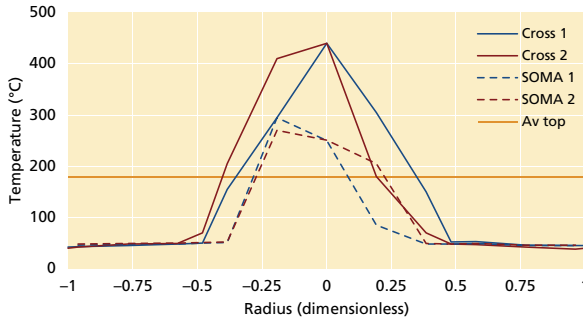

Figure A1.2 Comparison of radial temperature measurements with cross probe and SOMA, daily averages on a stable day

Pressure taps

Pressure taps indicate whether or not the gas flow is stable. Pressure taps indicate whether or not “short circuiting” of gas flow along the wall takes place. In stable periods the layers of coke and ore can be followed passing the taps.

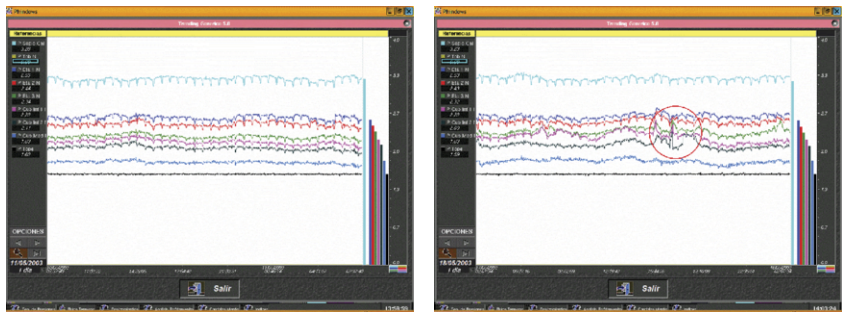

Figure A1.3 Pressure taps indicating the stability of the process, 24 hour graphs. The example shows stable (left) and unstable (right) operation.

Tuyere Cameras

Tuyere Cameras are becoming more standard. See Figure A1.4 for an example display. They give real time continuous monitoring from the control room, which enables immediate detection of tuyere blockage or lance damage, which can prevent the burn down of a blowpipe. In some countries, using the image analysis to automatically shut off the coal injection when a blockage is detected is permitted. In others a simpler more robust system is required for automatic shut-off, such as light meters or differential pressure on the downleg. (Chapter V). Operators are now developing more sophisticated image analysis

techniques to generate more process condition indicators. For example, Stelco reported (Ward et al, 2018) a signal processing technique, based on lack of light intensity, to record accretions appearing in front of the tuyeres. The frequency of such events is related to stove leaks, poor ferrous material quality and too-low cohesive zone position, which may be an early warning of tuyere failures. Different companies have similar indicators, like “low–low flow” at a tuyere stock ΔP below a minimum, or “dark” when using a light detector.

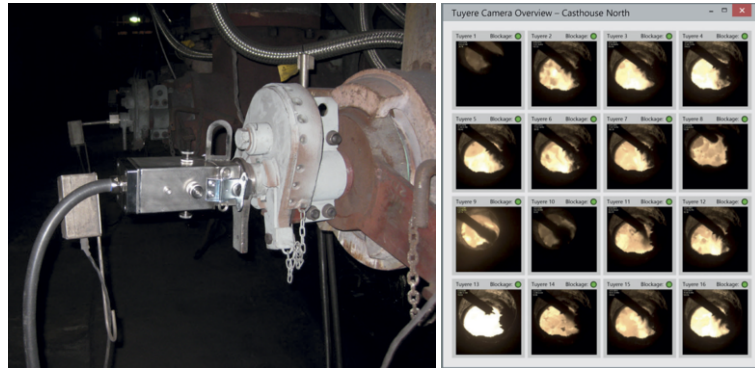

Figure A1.4. Typical tuyere camera and control room display.

Top cameras

Infrared camera technology now permits a small camera installed on the furnace cone to measure the stockline surface temperature between charging temperature up to 1200 °C. The camera creates digital images which can be recorded many times per second when required. Image data post-processing techniques have been reported (Huang et al, 2019) which generate virtual above burden temperature probe profiles, central gas flow strength and location, wall gas flow strength, and gas channeling events. Prior to processing the image, it must be corrected for distortion and to remove the effect of the rotating chute. Additional benefits reported are the ability to detect burden spraying, due to excessive moisture, and the fine-tuning of the charging mathematical model, particularly for coke/ore ratio in the center (Huang et al, 2017).

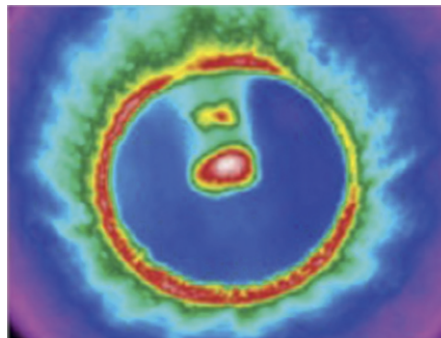

Figure A1.5. Example of wall gas flow, central gas flow and channel. (Huang et al, 2017)

Burden Profile Measurement

When aiming for low coke rates, it is important to have an accurate measurement of the layer shape in order to ensure that the coke is well distributed across the radius. There must be sufficient coke in each radial position to ensure that the ferrous layers do not stick together (Chapter VII). The burden profile is to a blast furnace what the steering wheel is to a car. Traditionally, measurement is done by a retractable profilometer. This device is inserted above the burden between charges and continually scans the stockline as it travels to the center and back. A sequence of measurements for each layer of the charging sequence is typically made each shift. A radar instrument is located at the back of the probe, with a 45 ° reflector at the front to divert the signal onto the stockline. Figure A1.6 shows the reflector and a typical profile result. This technique gives a high-resolution measurement of the layer shape, but across only one radius.

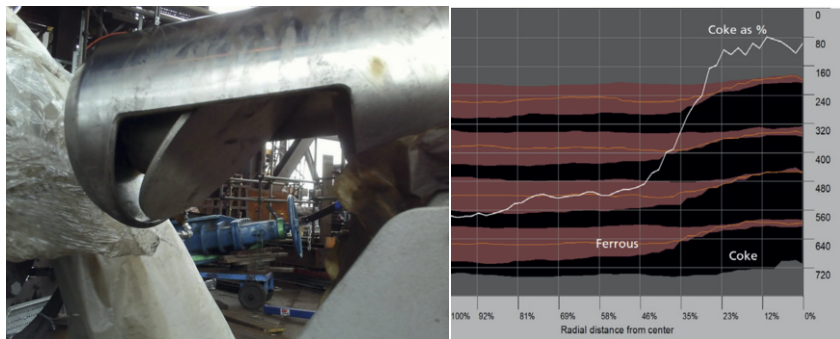

Figure A1.6 Profilometer measuring head showing the radar reflector and example output display from profilometer measurement

An alternative method is to use a 3D radar scanner located on the furnace cone. This continuously scans the entire stockline and calculates a 3D image. This can then be further processed to a number of 2D profiles along several diameters. Some companies report that such instruments are installed on all of their blast furnaces (Feilmayr, 2016).

Annex III *Rules of Thumb*

		coke rate	T _{flame}	T _{top}	ΔP
		kg/tHM	°C	°C	bar
PCI	+10 kg/tHM	-8.8	-26.6	9.4	0.014
Natural gas	+10 kg/tHM	-9.7	-75.8	20.1	0.054
Oil	+10 kg/tHM	-10.9	-45.7	13.5	0.027
O ₂	+1%	0.8	33.9	-14.0	-0.047
HBT	+10 °C	-0.9	5.2	-1.5	-0.007
Moisture	+10 g/m ³ STP	5.3	-42.5	8.6	0.040
Slag volume	+10 kg/tHM	0.7			0.005
Heat loss	+100 MJ/tHM	5.4	13.8	-0.4	0.039
Silicon	+0.1%	3.5			

Annex IV The Blast Furnace as a Chemical Reactor

A 4.1 Carbon and hydrogen

Oxygen in the hot blast and injectant are shortly after the raceway transformed to carbon monoxide (CO), while hydrogen (from blast moisture and injectants) is converted to H₂. CO and H₂ are stable at high temperatures (above 1000 °C) under blast furnace conditions. What happens with the gas when it ascends through the furnace and cools down?

First consider what happens with the carbon monoxide.

Carbon can give two types of oxides:

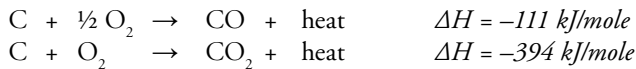

The first reaction takes place in the blast furnace, but CO₂ is not the final product in the raceway. The second reaction is more typical in a process like a power plant.

Note that in the second step much more heat is generated than in the first step. For this reason, CO should be converted to CO₂ as much as possible in the process. The ratio CO₂/(CO+CO₂) is called the gas utilization or gas efficiency η_{CO} and is used extensively in blast furnace operation.

In Figure A4.1 on the next page, the equilibrium Boudouard reaction ($2 \text{CO} \leftrightarrow \text{C} + \text{CO}_2$) is presented for various temperatures. At temperatures above 1000 °C, CO₂ is rapidly converted to CO, if in contact with coke. So, at the high temperatures in the bosh and melting zone of the blast furnace, only carbon monoxide is present. At temperatures below 500 °C, CO has a tendency to decompose into C + CO₂. The carbon formed in this way is very fine and is called “Boudouard” carbon. The formation of carbon from CO slows down at lower temperatures and is most pronounced at temperatures of 500–550 °C (Biswas, p 70). In operational practice, the carbon monoxide decomposition can be observed in refractory material, where there is a CO-containing atmosphere in the correct temperature region. CO decomposition jeopardizes the heat conductivity of refractories and can cause a brittle layer.

Water (H₂O) from blast moisture and injectants behaves in a similar way, since H₂O is rapidly converted in the presence of coke to H₂ and CO.

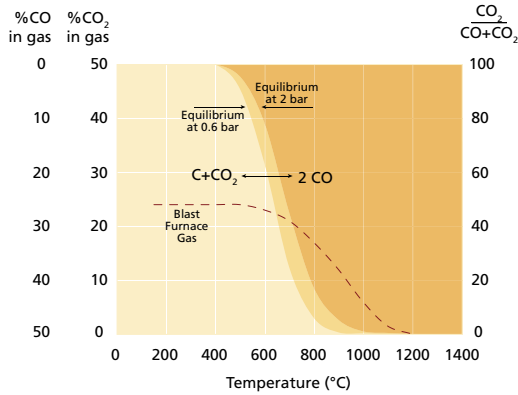

Figure A4.1 Boudouard reaction: the drawn lines indicates equilibrium at low top pressure furnaces and high top pressure furnaces, after Biswas, 1981. The dotted line shows the gas composition inside a blast furnace.

A4.2 Gas reduction of iron oxides

As soon as gas temperatures decrease below 1000 °C, the CO₂ becomes stable and reduction reactions can take place, such as (see Figure 4.2):

– For Hematite:



– For Magnetite:

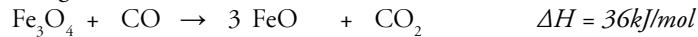

– For Wustite:

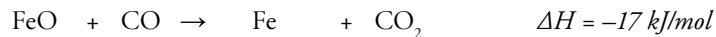

The reduction is called “gas reduction” because the oxygen is removed from the burden materials with CO gas. H₂ reacts in a similar way. In the literature it is also often called “indirect” reduction, since carbon is only indirectly involved in this reaction. The reduction of the FeO_{0.5} takes place via direct reduction.

Following the burden descent from the stockline, the reduction from hematite to magnetite starts at around 500 °C. The reduction from magnetite to wustite takes place in the temperature zone from 600 to 900 °C, while the reduction from wustite to iron takes place in the temperature region between 900 and 1200 °C. At the start of melting (1100–1200 °C) FeO_{0.5} is normally reached. Here FeO is used as a symbol for wustite, however the most stable composition is Fe_{0.95}O or FeO_{1.05}. The reactions are shown in Figure A4.2.

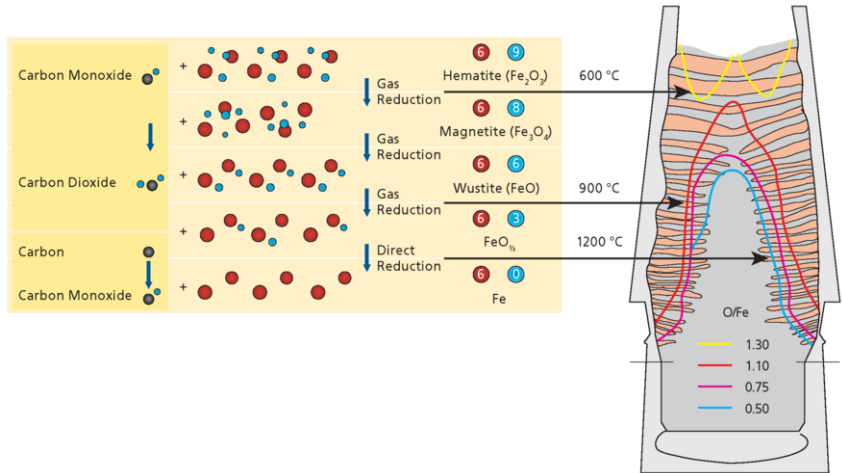

Figure A4.2 Overview of the reduction of iron oxides (black dots are carbon atoms, blue dots are oxygen atoms and red dots are iron atoms)

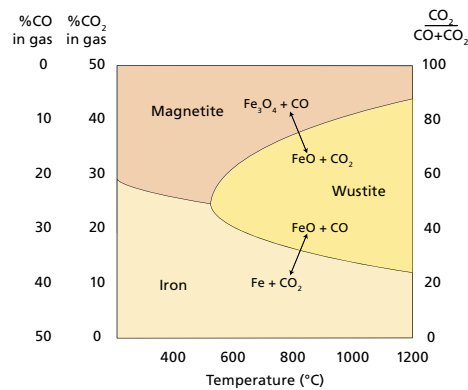

Figure A4.3 Schematic representation of the relation between temperatures, CO/CO₂ gas composition and iron oxides, the drawn lines indicate equilibrium

The equilibrium between the various iron oxides and the gas is shown in Figure A4.3. The figure shows the temperatures and gas compositions where further gas reduction of the burden is no longer possible. The reduction of wustite to iron requires gas with a relatively high percentage of CO. Gas utilization for reduction of wustite should be below 30 %. If CO₂ content is higher, wustite is no longer converted to iron by gas reduction.

The progress of the reduction reactions in a blast furnace can be detected in two different ways:

- Burden: from quenched furnaces an overview of the progress of the reduction can be derived. An example is shown in Figure A4.2
- Gas: by sending gas sampling devices down into the furnace, the progress of temperature/gas composition can be derived. Figure A4.4 shows typical results

from a gas sampling exercise. The data can be depicted in the graph of the equilibrium between gas and iron oxides. The gas normally shows a “thermal reserve zone”, that is, a zone in which the temperature does not change rapidly, as well as, a “chemical reserve zone”, a zone in which the chemical composition of the gas does not change. The thermal reserve zone decreases and can disappear when the furnace is pushed to high productivities.

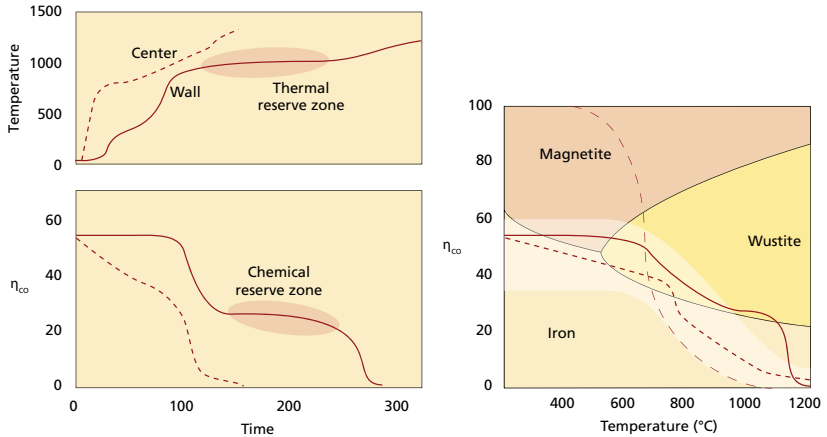

Figure A4.4 Gas composition in operating furnace. CO , CO_2 , H_2 and temperature were measured with descending probes (Chaigneau et al, 2001). Typical measurements from various furnaces are shaded (after McMaster, 2002). The coarse dotted line is the Boudouard equilibrium of Figure A4.1: CO_2 is stable at the left side of the line.

A4.3 Direct reduction of iron oxides

Gas in the blast furnace reduces iron oxides from hematite (Fe_2O_3) to a situation, where about half of the Fe atoms are metallic and half FeO. So, the O/Fe ratio when the burden starts melting is about 0.5 O per Fe atom. In efficient furnaces and furnaces using natural gas injection the O/Fe ratio can be lower, the ratio of 0.5 is used for explaining the mechanisms. As soon as burden materials start to soften, the layers become impermeable to gas and gas reduction stops. When the burden starts to melt around 1300 °C, reduction progresses, but any CO_2 or H_2O generated is rapidly converted to CO and H_2 . The resulting chemical reaction is



The reaction is called direct reduction, since in total the melting iron oxide consumes carbon directly. This is a confusing terminology, since “direct reduction plants” convert iron oxides by gas reduction at temperatures of 1000–1100 °C. In addition to the direct reduction of iron oxides, in the lower part of the blast furnace, a number of different reduction reactions take place: reduction of SiO_2 to Si, MnO to Mn, P_2O_5 to P, TiO_2 to Ti.

A4.4 Gas reduction and direct reduction combined

The direct reduction and gas reduction reactions combine for a very efficient process.

Suppose that all oxygen is removed by direct reduction. Then, the following reaction takes place:

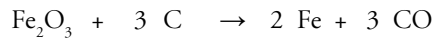

Hot metal contains about 945 kg Fe per tonne. Coke contains about 86 % carbon. Atomic weights of Fe and C are 55.85 and 12 respectively. A tonne of iron contains 16.9 kmole Fe (945/55.85). For every atom of iron, we need 1.5 atoms of carbon, so the carbon requirement is 25.4 kmole (1.5·16.9), which is 305 kg carbon (25.5·12). In addition, about 45 kg carbon is dissolved in iron. In total, 351 kg carbon is used per tonne of hot metal, which corresponds to only 408 kg of coke. This is a very low equivalent coke rate, and a blast furnace will not work, because the heat generated in this reaction is too low.

Now consider that all reduction reactions are done via gas reduction, what coke rate is required in this situation? It is assumed that coke combustion generates the CO required. The reaction is:

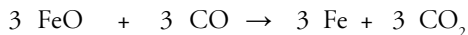

We only consider the reduction of wustite since the resulting gas is powerful enough to reduce magnetite and hematite. We know from the above (Figure A4.3) that for gas reduction the maximum gas utilization is 30 %. To get 30 % gas utilization more CO is needed and the reaction is (since 3/(3+7) = 30 %):

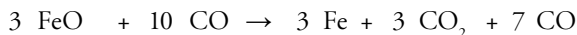

So, the coke requirement is calculated as above: every tonne of iron contains 16.9 kmole. There is a need for 10 carbon atoms per 3 atoms of Fe. So, the carbon requirement is 57 kmole (10/3·17), which corresponds to 684 kg carbon (57·12). Again, the extra 45 kg carbon in iron has to be added, yielding a carbon rate of 729 kg/tHM and a coke rate of 848 kg/tHM (729/0.86). This reaction has a poor coke rate and a high heat excess.

The conclusion of the considerations above is that the counter-current character of the blast furnace works efficiently to reduce the reductant rate by combining direct reduction in the lower furnace with gas reduction reaction in the upper furnace. Approximately 60–70 % of the oxygen of iron oxides is removed by gas and the remaining oxygen is removed by direct reduction.

A4.5 Reduction by hydrogen

Hydrogen is formed from moisture (H₂O) in the blast and injectants (hydrocarbons) in the raceway. Hydrogen can act as a reducing agent to remove oxygen and form water. The reaction is comparable with that for carbon monoxide:

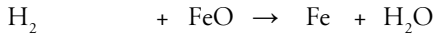

The major differences with the reactions for hydrogen and carbon monoxide are as follows:

- Figure A4.5 shows the equilibrium of the iron oxides and hydrogen (red lines) superimposed on the CO/CO₂ equilibrium lines. Hydrogen is more effective at temperatures above 821 °C. From measurements in the blast furnace, it has been shown that hydrogen reactions are already nearly complete at this temperature.
- Hydrogen utilization as measured from the top gas is normally 40–45 % while CO utilization is close to 50 %. At the FeO level (900 °C), hydrogen is utilized for 35 %, which means that it is already close to its final utilization of 40 %.
- Hydrogen is less effective as a reductant at lower temperatures, because it consumes heat when reducing iron oxides.

At high temperatures, the H₂O that is formed in the furnace reacts with coke:

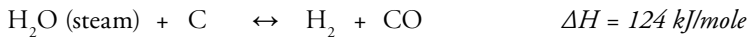

This reaction consumes a lot of heat. At high temperatures (over 1000 °C) the reaction proceeds rapidly to the right.

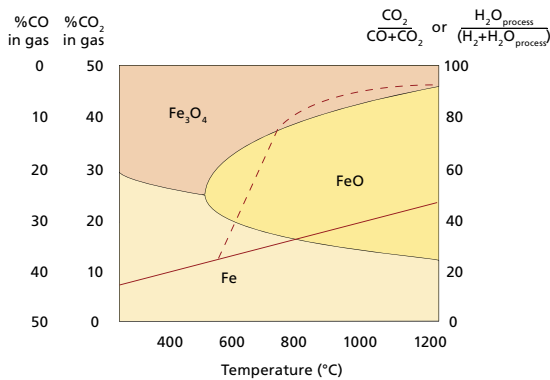

Figure A4.5 Equilibrium iron oxides with hydrogen (red) and carbon monoxide

At high temperatures (above 1000 °C) water vapor gasifies coke. At lower temperatures (800–1000 °C), the water–gas shift reaction becomes important:



In this temperature range, hydrogen is more effective as a reductant than carbon monoxide. This is shown in Figure A4.6, where the H_2 utilization/ CO utilization is larger than 1.

The water–gas shift reaction shifts to the right when the temperature decreases. The reaction approaches equilibrium rather fast at temperatures above $800\text{ }^\circ\text{C}$, but fails to reach equilibrium below approximately $730\text{ }^\circ\text{C}$.

The hydrogen utilisation of the top gas is defined as $\eta_{H_2} = H_2O/(H_2+H_2O)$, where H_2O refers to “process water”, water generated in the blast furnace process without moisture from burden and coke. The utilization is estimated from the H_2 input through the tuyeres; the H_2O_{process} is the difference between the hydrogen input and the hydrogen leaving the furnace with top gas, as measured with the gas analysis.

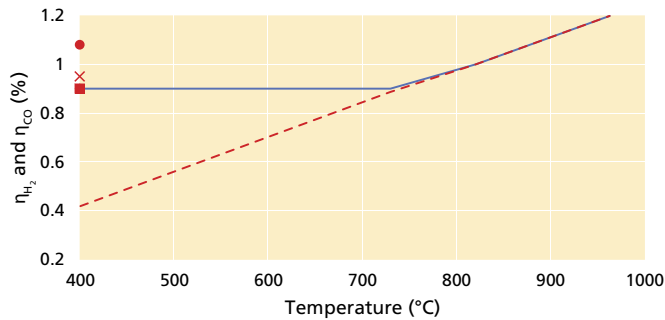

Figure A4.6 Water gas shift reaction showing the hydrogen utilization/ CO utilization. Above $821\text{ }^\circ\text{C}$ hydrogen is a more efficient reducer than CO . The red dotted line indicates the thermodynamic equilibrium that fails to set up in operating blast furnaces below $730\text{ }^\circ\text{C}$. The line drawn in blue indicates operational results. Dots are data from top gas in operating blast furnaces.

Annex V *Expert Systems and Models*

An expert system helps the operator to continuously analyze all process data and to suggest or execute corrective actions in real time. The corrective actions are based on the deviation of major process parameters from their target values and predefined rules of how to correct for the deviations. Any company with a book of “Standard Operating Procedures” can consider an expert system by automating these operating procedures in the process computer. The major advantages of expert systems are:

- Continuous monitoring of all relevant process parameters.
- Option of developing the system to improve decision-making rules.
- Apply operational experience developed over many years by various operators.
- Standardize decision making in process control and operations.
- Implement alarms or take actions if a parameter exceeds the control range.

However, an expert system has its limitations for some parts of the process and is not suitable for controlling special situations (blow-in, sudden chill). An expert system is no replacement for experienced blast furnace operations experts.

A5.1 Visualization of process conditions in real time

The process control system shows screens where the operator can monitor all the variables for a certain aspect of the process. An example is shown below. There are three important areas:

- Diagnostics: process parameters are scaled between -1 and $+1$, or between 0 and 1 , and “red” and “green” areas are presented, red showing parameters outside the normal control area.
- Control actions or suggested control actions. The suggested actions serve to establish a dialogue within the shift, which allows the operator to decide whether or not the suggested action is to be implemented. The comment of the operator on the suggested actions even when not implemented, allows optimization of the process rules within the system. In this case, the expert system helps for consistency of measures, since actions executed manually are operator-dependent and may come into conflict with the expert system. It is preferable to adjust the system and improve the recommended actions.
- “Open” or “closed” decisions on suggested actions: in the open situation, the expert system presents a suggested action, but does not react if no decision is made. Closed decisions are executed automatically after 20 minutes if no rejection has been received by the system. These actions must be taken based on the speed of the process, typically between 5 and 7 hours. 20 minutes may be (too) long, since 20 minutes plus system adjustment of weighing and burdening program leads to a delay of 45 to 50 minutes until a change enters physically into the blast furnace.

A5.2 What process parameters and diagnosis can be made?

The expert system follows a huge number of measurements in the furnace and makes a diagnosis whether or not the parameter is in a desired range. Among others, the following diagnoses are made:

- Burden descent: compares the burden descent of the last 24 hours with the last hour and analyzes whether or not the burden descent is slow, normal or accelerated. (See section on direct reduction)
- Slag and hot metal quantity produced and drained from the furnace. The production balance is made, based on the progress of the last 25 casts as a reference. Subsequently, the last cast and the last three casts are analyzed to monitor high, normal or low slag drainage. The same is done for hot metal.
- Thermal state of the furnace: based on temperature, hot metal carbon, silicon, sulfur and titanium as well as slag FeO level. The thermal state is considered low, normal or high.
- Stave temperatures and stave heat fluxes: continuous analysis of stave temperatures and heat fluxes on the various levels, defining 2 types of conditions: the current level and current tendency. The diagnosis sounds the alarm when 25 % of the temperatures are below lower level or above upper level limits with the corresponding decreasing or increasing tendency.
- Skull/scaffold formation: follows the temperature and heat fluxes through the staves and defines scaffold formation as decreasing tendencies of both parameters for the last 24 hours. To this end, the individual staves are taken in “areas” representing several staves. Occasionally it is found that the loss of thermal activity in the staves is also manifest in neighboring areas. The opposite of the skull/scaffold formation is called “peeling”, which is the loss of the skull. This is analyzed based on the same data.
- Charged burden: compares setpoint weights of materials charged with actual weights and monitors the deviation from setpoint.
- Hot blast stoves: analysis of the moments that stoves are changed for every stove, allowing the operator to operate the stoves within ± 10 °C of the target value.

A5.3 Process control actions

Process control in the blast furnace has various areas and targets.

- Thermal control: the liquid products have to be drained from the hearth at the desired temperatures.
- Chemical control: the hot metal and slag need to have the desired chemical composition.
- Gas flow control: the gas flow in the furnace can be monitored and has to be optimized for efficiency of contact between gas and burden.
- Casthouse control: the hot metal and slag have to be removed from the furnace hearth at the desired rates and intervals of time.
- Control of equipment like tuyeres and coolers.

- Incident control: how to manage unwanted and unexpected process conditions for which no cause is known: what to do if a furnace is out of control: slips, hangs, chills suddenly, etc.

In Table A5.1 below the various subjects for process control are summarized: the indicators used and the corrective actions. It shows a typical example of what can be done. Every company develops its own expert system, based on its own experiences and operating practices.

Field	indicator/diagnostics	corrective action
Thermal Control	Hot Metal Silicon	Step 1: adjust injection rate 2–5 kg/tHM
	Hot Metal Temperature	Step 2: adjust coke rate
	Hot Metal Carbon (Ti, Mn)	in severe chills:
	Slag FeO	Extra coke
Chemical Control	New chemical analysis burden materials	Change input according to guidelines
	Slag basicity	Change input
	Burden input	Adjust input
	Hot metal Manganese	Adjust input
Gas Flow Control	Coke % in center	Adjust central flow by increase/decrease coke % in center
	Coke % at wall	Correct burden distribution
	Drying capacity/water elimination	Increase gas volume/tHM (lower oxygen enrichment, higher fuel rate)
	Too high ΔP , total column	Lower blast volume
	Too high ΔP , upper or lower part	Check fines coming into furnace, check hearth drainage
	Wall gas flow as manifest from spikes in stove temperatures (peeling), high local heat loss or decreasing peaks	Adjust blast volume (longer term: burden distribution)
Casthouse Control	Slag and hot metal drainage	
Incidents	Burden level too low	Caused by charging system: extra coke, pull wind
		Caused by process: decrease wind volume, extra coke. control ΔP
	Sudden chills (temperature and silicon drop)	Extra coke, lower wind volume
	Water leakage/top gas hydrogen	From cooling system, burnt tuyeres: repair, a stop may be required

Table A5.1 Indicators and corrective actions in an expert system

An expert system is able to check in real time a huge number of measurements and is able to suggest process control actions to the operators for the various area. In the present section a few examples are provided of how an expert system works.

A5.4 Process control with an expert system

Thermal control

Thermal control can be based on the hot metal temperature and hot metal silicon. Both factors have their own weight. An example is, that the thermal stage of the furnace is judged from the average hot metal temperature and silicon of the last three casts. Since three casts represents a production, which is larger than the production coming from the complete working volume of the furnace, the hot metal temperature and silicon are always delayed by a number of hours. This means that the system checks whether or not there are indications of increased production rate, for example from the charging rate. If so, this is taken into account. The correction can be executed by changing fuel injection or by adjusting the coke rate. This type of choice is built into the system according to local experience and preferences.

Different blast furnaces can have different methods for thermal control. For instance, it can be focused on hot metal temperature. Hot metal silicon often gives an earlier indication of a cooling trend than hot metal temperature.

Control of injection (coal, gas)

The operator targets a constant injection rate per tonne of hot metal produced. Since the actual flow rate of the injectant is measured in kg/hr (coal) or m³ STP/hr (natural gas), the set point for the injection has to be corrected for the actual production. The main factor determining the actual production is the amount of oxygen per hour blown into the blast furnace. So, injectant control should take into account hot blast volume changes, as well as changes in oxygen enrichment and steam injection. An additional correction can be made for deviations in the direct reduction rate: if direct reduction increases (for example as a consequence of the input of more fines), then the production rate will increase, even if all set points at tuyeres are maintained. This can be observed from the charging rate. A faster response can be generated from continuous mass balance of the gas, as shown in Chapter VI. The replacement ratio of injectants has to be considered in order to obtain a constant energy balance.

Tracking the charge

When the burden is changed, the revised burden descends to the tuyeres in 5–7 hours. The tracking system visualizes where in the furnace the change is present in real time. This is important for extra coke and/or basicity changes when preparing for a furnace stop or shutdown. An example is shown in Figure A5.1 on the next page.

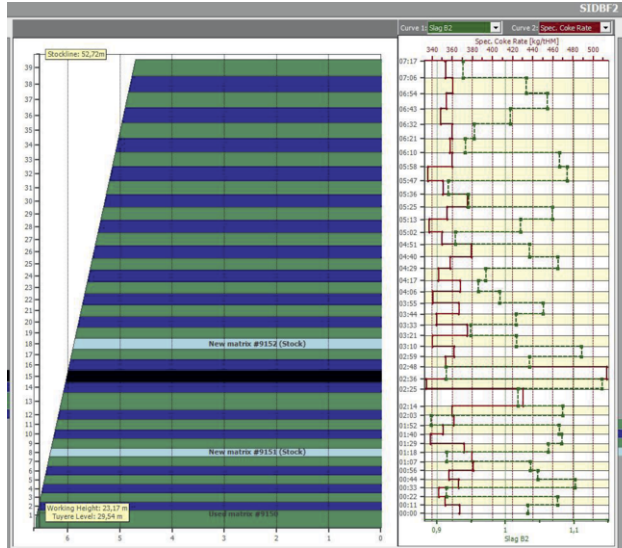

Figure A5.1 Tracking the charge: to monitor when changes are being processed with extra coke descending in the charge.

A5.5 Examples of models

A5.5.1 Mass and heat balance and minimum fuel rate model

The mass and heat balance model checks the input and output of the furnace on a daily basis. It does so by closing the material balance as well as the enthalpy balance. Most companies use a two-stage mass and heat balance, where the upper furnace and lower furnace are separated by the plane where it is considered that the gas temperature is 900 °C and the O/Fe ratio in burden is 1.

The mass and heat balance when used continuously can serve as an early warning signal for sudden chills, because the increase of direct reduction can be calculated in real time from the top gas composition. Moreover, whether there are deviations in the chemical composition and weights of raw materials can be ascertained.

A5.5.2 Hearth wear model

The hearth of a blast furnace is equipped with numerous thermocouples. The temperature readings combined with the thermal properties of the refractories can be used to calculate the isotherms in the furnace hearth. The isotherm of 1150 °C represents the solid-liquid interface, so is indicative for the hearth refractory wear. An example is shown in Figure A5.2

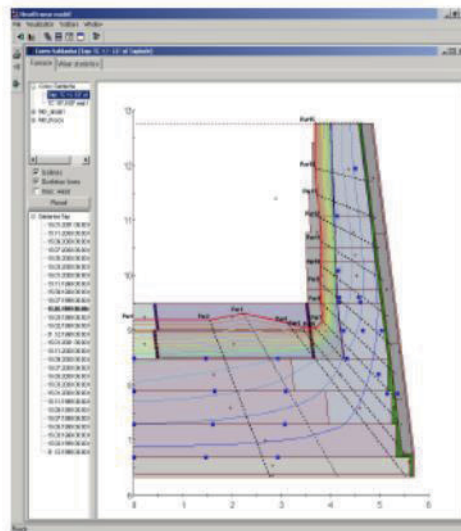

Figure A5.2 Hearth isotherms

The actual condition of the hearth is shown by the actual thermocouples. But to estimate the refractory condition of the hearth, the campaign highest readings have to be analyzed: the highest value in the campaign indicates the limit of good hearth refractories, since once refractories have been lost, they are not restored. Instead, scabs are formed in the hearth. Some blast furnace hearth models even calculate the thickness of the skull on the hearth sidewall and bottom.

Use of the model helps to maintain the integrity of the hearth wear monitoring system. Many thermocouples fail during a campaign, so a program for repair and/or elimination from the model has to be in place in order to secure accurate results.

While the model is very useful for repair/reline planning, daily operations are more reactive to high temperature readings in a certain area. If temperatures at the hearth wall rise too high, there is the risk of a break-out. Most operators know the weak points of their hearth refractory and alarm temperatures are put into the hearth monitoring system. When temperatures rise too high, corrective actions are possible, like plugging tuyeres above the affected area.

Annex VI *Coke quality tests*

Coke quality is distinguished by cold strength and hot strength. Coke cold strength is measured with drum tests. Drum tests are simply cold simulations of the load on the coke during its descent through the blast furnace. The standard is ISO 556–2020: “Coke larger than 20 mm determination of mechanical strength”. If starting with a different coke size, such as larger than 60 mm, the coke starting size used must be stated. The standard is larger than 20 mm. The standard sample weight is 50 kg, although most plants now use 25 kg. If so, this should be stated. The micum slope is generally done on a sample of coke larger than 20 mm. It was developed under a European research project to assess bosh coke compared to the feed coke, being more sensitive and enabling better differentiation

To have a better understanding of the coke degradation mechanism under mechanical stress we look at Figure A6.1. Here the percentage of the coke larger than 40 mm and smaller than 10 mm of the sample is presented as a function of the number of rotations of the drum.

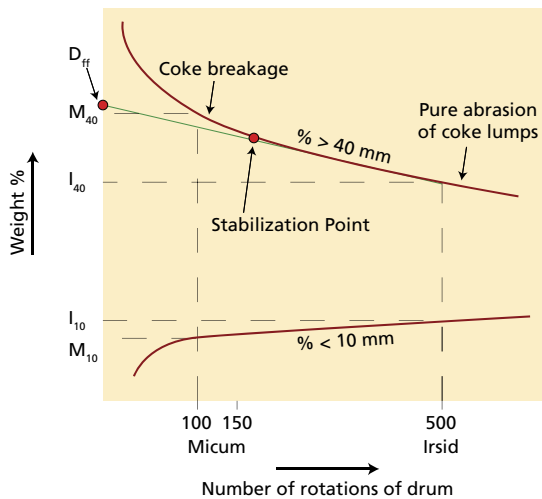

Figure A6.1 Comparison of different mechanical tumble tests and results.

From this figure it can be seen that the lumps larger than 40 mm start to degrade by breakage only, until the point of stabilization is reached, when no further breakage occurs. This point is reached at between 100 and 150 rotations. From this point on, further degradation is mainly by abrasion, although some breakage still occurs, to a lesser and lesser extent as the number of rotations increases. The weight percentage of coke larger than 40 mm after 100 rotations is called M_{40} and the percentage after 500 rotations is called the I_{40} . The weight percentage of coke smaller than 10 mm is called M_{10} and I_{10} respectively.

Besides these values, the Fissure Free Size, the Stabilization Index and the Micum slope have been introduced as coke quality parameters. Although in this test the parameter used is not the percentage larger than 40 mm of the coke but the average mean size (AMS) as a function of rotations. We will explain these concepts with Figure A6.1 as well. First a line (shown in green) is fitted to the curve of abrasion–only. Then the green line of abrasion is extrapolated only to the y–intercept (zero rotations) and the AMS of the coke at this point is calculated. This yields the Fissure Free Size (FFS), also known as Dff. This then represents the size at which there would be no degradation due to breakage, but only abrasion.

The slope of the green line of abrasion–only is called the Micum Slope. Some mills consider this to be a better way to evaluate abrasability than traditional M_{10} or I_{10} . The FFS was developed to simulate a maximum obtainable (theoretical) size for stabilized coke. Some believe the FFS approximately represents the size of stabilized industrial coke at the blast furnace stock line, which is then considered a more suitable controlling parameter. A stabilization index can also be defined as FFS/AMS , for which the maximum will be 1 for fully stabilized coke.

Tests for chemical reactivity and hot strength are elaborated in Section 4.5.3.

Annex VII *Rist diagram*

The Rist diagram is a graphical representation of the mass and heat balance of the blast furnace process. Visually, it shows how certain blast furnace process parameters are linked and what the consequences are of changes in these parameters.

This appendix explains the construction of the Rist diagram, based on simplifications of the combined mass and heat balances.

If the graphical representation is used in a predictive manner, a third balance is required by dividing the furnace into an upper and a lower part, with the balance over the lower part giving the model its predictive character. Further details are in the references: Rist and Bonnivard (1963), Rist and Meysson (1964), Rist (1977) and Peacey and Davenport (1979), which are at the base of the analyses below.

A7.1 Mass balance

For a simplified mass balance over the blast furnace, only three elements are of importance, Fe, C and O.

$$n_{\text{Fe}}^i = n_{\text{Fe}}^o \quad n_{\text{C}}^i = n_{\text{C}}^o \quad n_{\text{O}}^i = n_{\text{O}}^o$$

n indicates mole of input (i) and output (o) of each of the three elements, expressed per mole Fe in the hot metal. For simplification, it is assumed that the elements enter and leave the furnace as follows:

Element	Input	Output
Fe	Iron oxide	Hot metal
C	Coke	CO, CO ₂ , C in hot metal
O	Iron oxide, hot blast	CO and CO ₂

So, nitrogen in the air and slag components from burden, coke and or coal are ignored. To develop the mass balances further, definitions of both ratios and fractions are introduced. Top gas composition can then be described as the following ratio: $(\%C)^g$. For pure CO₂ this ratio is 2 and for pure CO this ratio is 1. Consequently, the molar fractions X of CO₂ and CO in the top gas are respectively:

$$X_{\text{CO}_2}^g = (\%C)^g - 1$$

$$X_{\text{CO}}^g = 2 - (\%C)^g$$

This obeys the rule that the sum of these two fractions equals one.

The amount of carbon in the top gas (per mole Fe in hot metal) is defined as n_{C}^{g} . In a similar way the molar ratio of O in the oxides can be defined: $(\text{O}/\text{Fe})^{\text{x}}$. For hematite (Fe_2O_3), this ratio is $3/2$ and for magnetite (Fe_3O_4) this is $4/3$.

Finally, for carbon in the hot metal the ratio is given as $(\text{C}/\text{Fe})^{\text{m}}$ which equals the moles of carbon in hot metal per mole Fe in hot metal.

Now it is possible to define the mass balances.

Hot metal

The iron enters the furnace with the ferrous burden and leaves the furnace as hot metal. Per mole Fe in the hot metal the balance is:

$$n_{\text{Fe}}^{\text{i}} = n_{\text{Fe}}^{\text{o}} = 1$$

Carbon

Carbon enters the furnace as coke and leaves the furnace with the top gas and partly with the hot metal:

$$n_{\text{C}}^{\text{i}} = n_{\text{C}}^{\text{o}} = n_{\text{C}}^{\text{g}} + (\text{C}/\text{Fe})^{\text{m}}$$

Oxygen

Oxygen enters the furnace with the hot blast and with the iron oxide:

$$n_{\text{O}}^{\text{i}} = n_{\text{O}}^{\text{B}} + (\text{O}/\text{Fe})^{\text{x}}$$

and oxygen leaves the furnace with the top gas:

$$n_{\text{O}}^{\text{o}} = n_{\text{C}}^{\text{g}} \cdot (\text{O}/\text{C})^{\text{g}}$$

If these two equations are combined with of course $n_{\text{O}}^{\text{i}} = n_{\text{O}}^{\text{o}}$:

$$n_{\text{O}}^{\text{B}} + (\text{O}/\text{Fe})^{\text{x}} = n_{\text{C}}^{\text{g}} \cdot (\text{O}/\text{C})^{\text{g}} \quad (\text{A7.1})$$

Equation (A7.1) can graphically be represented as a straight line with x-axis the O/C and y-axis the O/Fe: Figure A7.1. The intercept with the y-axis is n_{O}^{B} and the slope is n_{C}^{g} .

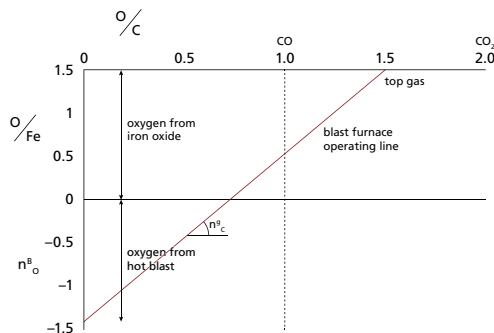

Figure A7.1 Rist diagram based on the mass balance of a blast furnace

This very simplified mass balance model can be used to check a measured top gas composition against the inputs of the furnace based on the operating line of that furnace.

However, if for example a prediction of the coke consumption or hot blast is required, the mass balance model needs to be expanded with a heat balance over the furnace.

A7.2 Heat balance

With respect to the heat balance over the furnace: heat in = heat out. This is equal to the balance between heat demand and heat supply:

Heat Demand D = reduction of iron oxides and melting of hot metal.

Heat Supply S = CO and CO₂ generation from carbon at 298 K (25 °C)

With $D = S$

$$S = n_{\text{CO}}^g \cdot H_{298}^0(\text{CO}) + n_{\text{CO}_2}^g \cdot H_{298}^0(\text{CO}_2)$$

$$H_{298}^0(\text{CO}) = -111000 \text{ kJ/mole CO}$$

$$H_{298}^0(\text{CO}_2) = -394000 \text{ kJ/mole CO}_2$$

In front of the tuyeres, only CO is generated, all originating from C. In the upper part of the furnace, a certain fraction is converted into CO₂

$$n_{\text{CO}}^g = n_{\text{C}}^g \cdot X_{\text{CO}}^g = n_{\text{C}}^g \cdot \{2 - (\text{O/C})^g\}$$

$$n_{\text{CO}_2}^g = n_{\text{C}}^g \cdot X_{\text{CO}_2}^g = n_{\text{C}}^g \cdot \{(\text{O/C})^g - 1\}$$

When these two equations are combined:

$$D = S = n_{\text{C}}^g \cdot \{283000 \cdot (\text{O/C})^g - 172000\} \quad (\text{A7.2})$$

Other sources of heat demand which have been neglected so far can be added, like heat losses and slag reactions.

If the heat balance is combined with the mass balance, the model becomes predictive with respect to coke demand and top gas analysis.

A7.3 Combination of mass and heat balance

By combining (A7.1) and (A7.2) into:

$$n_{\text{O}}^B + (\text{O/Fe})^x - \frac{D}{283000} = n_{\text{C}}^g \cdot \frac{172000}{283000} \quad (\text{A7.3})$$

an equation with 4 variables is obtained. If burden composition $(\text{O/Fe})^x$ and heat demand D are specified, two variables remain. If either n_{C}^g (moles carbon associated with gas \approx coke consumption) or n_{O}^B (moles oxygen in hot blast \approx productivity) is chosen, the other variable is defined and the whole blast furnace operation is defined.

Equation A7.3 can be rewritten in a form $\{y_2 - y_1\} = M \{x_2 - x_1\}$:

$$\left\{ (\text{O/Fe})^x - \frac{D}{283000} \right\} - (-n_{\text{O}}^B) = n_{\text{C}}^g \left\{ \frac{172000}{283000} - 0 \right\} \quad (\text{A7.4})$$

The equation in this format equals in Figure A7.1 the straight line with slope n_{O}^{g} and at the intercept of the y-axis, where $(\text{O}/\text{C}) = 0$, $(\text{O}/\text{Fe}) = -n_{\text{O}}^{\text{g}}$.

However, this straight line also has to go through the point:

$$\left(\frac{\text{O}}{\text{C}}\right) = \frac{172000}{283000} = 0.61 \quad \frac{\text{O}}{\text{Fe}} = \left(\frac{\text{O}}{\text{Fe}}\right)^x - \frac{D}{283000}$$

At a given burden composition $\left(\frac{\text{O}}{\text{Fe}}\right)^x$ and heat demand D , the actual O/Fe associated with $(\text{O}/\text{C}) = 0.61$ can be determined and with that, the enthalpy point H in the Rist diagram is fixed.

Furthermore, top gas composition will be between 100% CO and 100% CO_2 and with that, the whole operating area of a blast furnace is fixed, based on heat and mass balances. In Figure A7.2, hematite is chosen as burden and the specific heat demand is set at $D = 486000 \text{ kJ/mole Fe}$.

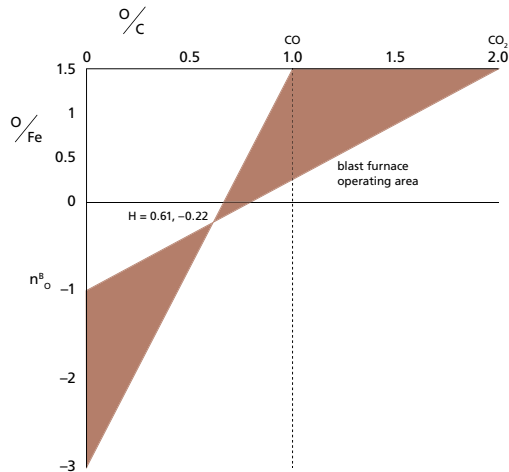

Figure A7.2 Rist diagram with the working area of the blast furnace. Boundaries set by heat and mass balance

One parameter still has to be chosen in this model (either n_{O}^{B} or n_{C}^{g}). In order to make the optimal operating condition completely independent, another fixed point apart from H is required in equation A7.4. This requires an additional equation, derived from dividing the furnace into an upper and a lower part, see paragraph A7.4.

A7.4 Mass balance over lower part of the furnace

The blast furnace can be split into two sections which can be seen independently of each other, as long as for both parts a correct heat and mass balance can be made. This split is best done at the thermal and chemical reserve zone, where equilibrium between gas and burden can be assumed.

If we assume that all direct reduction occurs in the bottom part, and that wustite is the only oxide phase in equilibrium with CO/CO_2 , then it is possible to create the following mass balance, analogue to the mass balance equation of paragraph A7.1.

$$n_{\text{O}}^{\text{B}} \cdot (\text{O}/\text{Fe})^{\text{wustite}} = n_{\text{C}}^{\text{g}} \cdot (\text{O}/\text{C})^{\text{wustite equilibrium}} \quad (\text{A7.5})$$

From the iron oxide equilibrium diagram, it is known that wustite ($\text{O}/\text{Fe} = 1.06$) at $950\text{ }^\circ\text{C}$ is in equilibrium at $\eta_{\text{CO}} = 30\%$ ($\text{O}/\text{C} = 1.3$).

The optimum operating line should intercept with this point, and a second point, the wustite point W, is created. This fixes the operating line, combined with point H and both n_{O}^{B} and n_{C}^{g} are now set: A7.3.

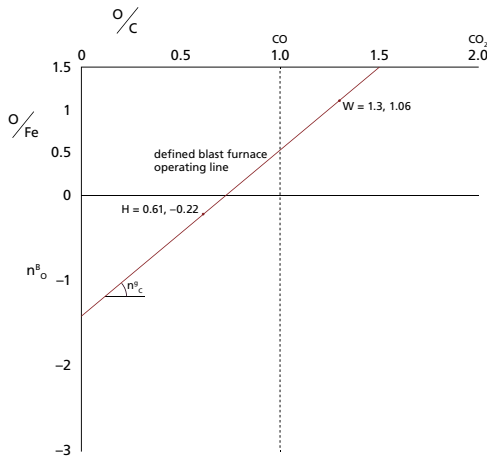

Figure A7.3 Rist diagram with an operating line fixed by its enthalpy point and the wustite equilibrium line

The model has now become predictive with respect to coke consumption (n_{C}^{g}), hot blast (n_{O}^{B}) and top gas composition ($\text{O}/\text{C}^{\text{topgas}}$). Any change in burden, hot blast temperature, PCI, oxygen enrichment, other reducing reactions, slag and so forth can be incorporated in the model through $(\text{O}/\text{Fe})^{\text{f}}$ and heat demand D.

A measured operating line of an existing operation can also be offset against the optimal operating line and the efficiency of the process can be judged.

The effects of introducing hydrogen from PCI, natural gas injection or simple moisture in the hot blast can also be calculated through the mass and heat balances, but this will complicate the simple graphical representation considerably.

Annex VIII *References*

- Agarwal, J.C.; Brown, F.C.; Chin, D.L.; Frydenlund, A.R.; Jessiman, N.S.: *The Use of Total Thermal-plus-Chemical Energy above 2700 °F to Describe Blast Furnace Operations*. Charles River Associates Incorporated, 1991.
- Bar-Ziv, E.; Kantorovich, I.I.: *Mutual Effects of Porosity and Reactivity in Char Oxidation*. Progress in Energy & Combustion Science, Vol. 27, Issue 6, 2001, pages 667–697.
- Biswas, A.K.: *Principles of Blast Furnace Ironmaking*. Cootha Publishing House, Brisbane, Australia, 1981.
- Bonnekamp, H.; Engel, K.; Fix, W.; Grebe, K.; Winzer, G.: *The Freezing with Nitrogen and Dissection of Mannesmann's No. 5 Blast Furnace*. Proceedings of the 43rd Ironmaking Conference, Chicago, USA, 1984, pages 139–150.
- Cameron, I.; Sukhram, M.; Lefebvre, K.; Davenport, W.: *Blast Furnace Ironmaking, Analysis, Control, and Optimization*. Elsevier, Amsterdam, The Netherlands, 2020.
- Carpenter, A.: *Use of PCI in Blast Furnaces*. IEA Clean Coal Center, London, 2006.
- Chaigneau, R.; Bakker, T.; Steeghs, A.; Bergstrand, R.: *Quality Assessment of Ferrous Burden: Utopian dream?* Proceedings of the 60th Ironmaking Conference, Baltimore, USA, 2000, pages 689–703.
- Chaigneau, R.: *Complex Calcium Ferrites in the Blast Furnace Process*. PhD Thesis, Delft University Press, Delft, 1994.
- Committee for Fundamental Metallurgy of the Verein Deutscher Eisenhüttenleute: *Slag Atlas*. Verlag Stahleisen, Düsseldorf, 1981.
- Danshin, V.; Chernousov, P.: *Handbook of Blast Furnace Worker*. Metallurgiya, Chelyabinsk, Russia, 1989, page 190.
- Gavel, D.J.: *Shifting the limits of nut coke use in the ironmaking blast furnace*. PhD Thesis, Delft University of Technology, Delft, The Netherlands, 2020.
- Feilmayr, C.; Schuster, S.; Ganglberger, V.; Lackner, B.; Zankl, D.; Stegellner, L.: *Innovative Tools for Process Optimization – Burden Surface Scanning via Beamforming Radar and Measurement of the Top Gas Temperature Distribution*. Proceedings of the 7th European Coke and Ironmaking Congress, Linz, Austria, 2016, pages 151–158.

- Etchevarne, P.; Margot, S.; Musante, R.; Oreggioni, S.; Baglivo, O.: *Influence of Chemical Composition of Sinter on Metallurgical Properties of the Burden of Ternium Argentina Blast Furnace No. 2*. Proceedings of the 22nd IAS Steel Conference, Rosario, Argentina, 2018.
- Fernández-González, D.; Ruiz-Bustinza, I.; Mochón, J.; González-Gasca, C.; Verdeja González, L.F.: *Iron Ore Sintering: Process*. Mineral Processing and Extractive Metallurgy Review, Volume 38, Issue 4, 2017, pages 215–227.
- Geerdes, M.; Van der Vliet, C.; Driessen, J.; Toxopeus, H.: *Control of a High Productivity Blast Furnace by Material Distribution*. Proceedings of the 50th Ironmaking Conference, Washington, USA, 1991, pages 367–378.
- Geerdes, M.: *Co-Injection of Coal and Gas in Blast Furnaces: Are there Hidden Benefits?* Iron and Steel Technology, Vol. 13, Issue 4, 2016, pages 82–88.
- Geerdes, M.; Warren, P.: *How Iron Ore Melts: Role of Coke and Nut Coke*. Proceedings of the 8th International Congress on Science and Technology of Ironmaking, Vienna, Austria, 2018, pages 380–385.
- Grebe, K.; Keddeinis, H.; Stricker, K.P.: *Untersuchungen über den Niedrigtemperaturzerfall von Sinter*. Stahl und Eisen, No. 100, 1980, pages 973–982.
- Grosspietsch, K.-H.; Lungen, H.-B.: *Coke Quality Requirements by European Blast Furnace Operators*. Stahl und Eisen, Vol. 120, Issue 9, 2000, pages 35–42.
- Gupta, S.; Al-Omari, Y.; Sahajwalla, V.; French, D.: *Influence of Carbon Structure and Mineral Association of Coals on Their Combustion Characteristics for Pulverized Coal Injection (PCI) Application*. Metallurgical and Materials Transactions B, Vol. 37B, 2006, pages 457–473.
- Hartig, W.; Langner, K.; Lungen, H.B.; Stricker, K.P.: *Measures for Increasing the Productivity of Blast Furnace*. Proceedings of the 59th Ironmaking Conference, Pittsburgh, USA, 2000, pages 3–16.
- Kolijn, C.: *International Cokemaking Issues*. 3rd McMaster Cokemaking Course, McMaster University, Hamilton, Canada, 2001.
- Hippo, E.; Walker, P.L.: *Reactivity of Heat-Treated Coals in Carbon Dioxide at 900 °C*. Fuel, Vol. 54, Issue 4, 1975, pages 246–248.
- Huang, D.; Andrade, M.; Walpole, C.; Caplick, C.: *Data Post-Processing for Above Burden Infrared Camera (ABirC) System*. Proceedings of the AISTech 2019 Conference & Exposition, Pittsburgh, USA, 2019, pages 547–560.

Huang, D.; Andrade, M.; White, D.: *Blast Furnace Above–Burden Infrared Camera*. Iron & Steel Technology, No. 3, 2017, pages 44–56.

Raipala, K.: *On Hearth Phenomena and Hot Metal Carbon Content in Blast Furnace*. PhD Thesis, Helsinki University of Technology Publications in Material Science and Metallurgy, Espoo, 2003.

Lüngen, H.B.; Schmöle, P.: *Comparison of Blast Furnace Operation Modes in the World*. Proceedings of the 8th International Congress on Science and Technology of Ironmaking, Vienna, Austria, 2018, pages 1054–1063.

Nightingale, R.J.: *The Development of Hearth Voidage Estimation and Deadman Cleanliness Index*. PhD Thesis, University of Wollongong, 2000.

Opbergen, R. van; Toxopeus, H.: *Modelling the Taphole and Casting Practice*. Proceedings of the 27th McMaster Symposium on Iron and Steelmaking, Hamilton, Canada, 1999.

Pagter, J. de; Molenaar, R.: *Taphole Experience at BF6 and BF7 of Corus Strip Products IJmuiden*. Proceedings of the 29th McMaster Ironmaking Conference, Hamilton, Canada, 2001, pages 107–125.

Pardo, N.; Moya, J.A.; Vatopoulos, K.: *Prospective Scenarios on Energy Efficiency and CO₂ Emissions in the EU Iron & Steel Industry*. EUR Scientific and Technical Research Series, Publications Office of the European Union, 2012.

Peacy, J.G.; Davenport, W.G.: *The Iron Blast Furnace – Theory and Practice*. Pergamon Press, Oxford, United Kingdom, 1979.

Rist, A.; Bonnivard, G. – *Revue de Métallurgie*, Vol. 60, 1963, pages 23–38.

Rist, A.; Meysson, N. – *Revue de Métallurgie*, Vol. 61, 1964, pages 121–46.

Rist, A.; Meysson, N.: *A Dual Graphic Representation of the Blast Furnace Mass and Heat Balances*. Proceedings of the 25th Ironmaking Conference, Philadelphia, USA, 1996, pages 88–98.

Rist, A.: *Solving Simple Blast Furnace Problems by Means of the Operating Diagram*. Blast Furnace Ironmaking, 1977, pages 4/1–4/37.

Santos Assis, P.; Batista Vieira, C.; Nolasco Sobrinho, P.J.: *New Developments for Powder Coal Injection into the Blast Furnace*. Steel Research International, Vol. 75, Issue 4, 2004, pages 235–239.

Schoone, E.E.; Toxopeus, H.L.; Vos, D.: *Trials with a 100% Pellet Burden*. Proceedings of the 54th Ironmaking Conference, Nashville, USA, 1995, pages 465–470.

- Sergeant, R.; Bonte, L.; Huysse, K.; Daelman, A.: *Hearth Management at Sidmar for an Optimal Hot Metal and Slag Evacuation*. Proceedings of the 5th European Coke and Ironmaking Congress, Stockholm, Sweden, Vol. 2, 2005.
- Singh, B.N.; De, A.; Rawat, Y.F.; Das, R.C.; Chatterjee, A. – Iron and Steel International, 1984, pages 135ff.
- Song, Q.: *Effect of Nut Coke on the Performance of the Ironmaking Blast Furnace*. PhD Thesis, Delft University of Technology, Delft, The Netherlands, 2013.
- Steer, J.M.; Marsh, T.R.; Sexton, D.; Greenslade, M.: *A Comparison of Partially Burnt Coal Chars and the Implications of their Properties on the Blast Furnace Process*. Fuel Processing Technology, Vol. 176, 2018, pages 230–239.
- Toxopeus, H.L.; Steeghs, A.G.S.; Van den Boer, J.F.C.: *PCI at the Start of the 21st Century*. Proceedings of the 60th Ironmaking Conference, Baltimore, USA, 2001, pages 736–742.
- Yaniga, S.E.; Francis, W.P.: *Tuyere Life Improvements and Operating Enhancements on Great Lakes B–2 Blast Furnace*. Proceedings of the AISTech 2010 Conference & Exposition, Pittsburgh, USA, 2010, pages 499–507.
- Yu, J.; Lucas, J.A.; Wall, T.: *Formation of the Structure of Chars during Devolatilisation of Pulverized Coal and its Thermoproperties: A Review*. Progress in Energy and Combustion Science, Vol. 33, Issue 2, 2006, pages 135–170.
- Vander, T.; Alvarez, R.; Ferraro, M.; Fohl, J.; Hofherr, K.; Huart, J.; Mattila, E.; Propson, R.; Willmers, R.; Van der Velden, B.: *Coke Quality Improvement Possibilities and Limitations*. Proceedings of the 3rd International Cokemaking Congress, Gent, Belgium, 1996, pages 28–37.
- Ward, N.; Klaas, M.; D'Alessio, J.; Badglet, P.: *Blast Furnace Process Monitoring and Control Through the Use of Tuyere Camera Technology*. Iron & Steel Technology, March 2018.

Index

Active coke zone	13
Adherences to furnace wall	211
Alkali	208
Asymmetry, circumferential	114
Asymmetry, radial	113
Asymmetry, tuyere without PCI	115
Banded iron formation	24
Basicity	155
Blast furnace contents, quantitative	20
Blast furnace cooling systems	9
Blast furnace efficiency	109
Blast furnace process, countercurrent	13
Blast furnace process, gas from coke and coal	11
Blast furnace process, general	3
Blast furnace process, internal layer structure	14
Blast furnace profile	15
Blast furnace temperature profile	5
Blast furnace, definitions of volume	7
Blow down	219
Blow-in, empty furnace	221
Blowpipe failure	216
Boudouard reaction	235
Briquettes	41
Burden calculation	88
Burden composition, worldwide	190
Burden descent, erratic	120
Burden descent, vertical forces	122
Burden distribution, cohesive zones	125
Burden distribution, fines	129
Burden distribution, high pellet operation	196
Burden distribution, ideal	128
Burden distribution, nut coke	129
Burden distribution, two types sinter	130
Burden fines	197
Burden movement	118
Burden optimization	195
Burden profile measurement	232

Burden selection	190
Burden, cold strength	29
Burden, fines	26
Burden, interaction components	42,43
Burden, processing the	17
Burden, quality demands	26
Burden, quality tests	28
Burden, reducibility	30
Burden, reduction–disintegration	30
Burden, softening and melting	28, 193
Camera, top	231
Camera, tuyere	231
Carbon, reactions	235
Casthouse operation	161
Casthouse operation monitoring	167
Casthouse simulation	169
Casting delays	178
Central working process	126
Channelling	207
Charges, number in blast furnace	21
Chemical reserve zone	238
Chilled furnace	224
Chute rotation direction	116
Coal blending for injection	74
Coal gasification	74
Coal gasification after injection	75
Coal gasification, incomplete	79
Coal injection, circumferential symmetry	80
Coal injection, coal backing up	81
Coal injection, equipment	70
Coal injection, process control with	76
Coal injection, replacement ratio	71
Coal injection, thermal control	79
Coal–oxygen working area	77
Coal quality for injection	72
Coal volatile matter	72
Coal–gas coinjection	85
Cohesive zone	13
Coke deadman	13
Coke deadman	58
Coke deadman cleanliness	60
Coke degradation	51
Coke layer	133
Coke mess	226
Coke quality	50
Coke quality parameters	63

Coke quality tests	248
Coke rate, minimum	134
Coke size	54
Coke strength	55
Coke use in furnace	101
Coke, C_{fix}	49
Coke, function	47
Coke, hot strength	57
Coke, movement towards tuyeres	164
Coke, nut	65
Coke, reactivity	57
Coke, residence time	48
Coke, screening	65
Coke, stockyard	64
Coke, voidage	65
Control , gas flow	189
Control hot blast	188
Control, chemical ~ burden	44
Control, slag basicity	187
Control, thermal	186
CRI	57
CSR	57
Direct reduction	92
Direct reduction	238
Direct reduction estimation	94
Double bell furnaces	136
Dry furnace condition	166
Efficiency, furnace: see utilization, gas	
Enthalpy balance, see Heat balance	
Expert systems	242
Flame temperature	96
Flame temperature estimation	97
Flooding limits	147
Gas cleaning	9
Gas composition in blast furnace	98
Gas composition in blast furnace, measured	191
Gas flow through furnace	16
Gas reduction	236
Greenhouse gas emissions	226
Hanging and slipping	205
Harmonic and average mean size	51
Hearth wear model	247

Heat balance	99
Hematite	17
Hot metal formation	147
Hot metal production, global	2
Hot metal temperature	187
Hot metal, properties of high silicon -	151
Hydrogen from injectants	85
Hydrogen utilization	241
Hydrogen, reducing iron oxide	240
Injection, coal, natural gas, oil	67
Instrumentation	229
Iron ore	24
K-factor	103
Kinetic energy blast	105
Liquid level and process	162
Lump ore	40
Magnetite	17
Melting of iron ore	145
Metallic charge	41
Mixed layer	132
Moisture input with burden and coke	200
Moisture recirculation	203
Momentum, blast see Kinetic energy	
Monitoring drying capacity	204
Natural gas injection	82
Natural gas injection, thermal control	83
Natural gas oxygen working area	83
Ore free center	128
Ore layer	133
Oxygen lancing	180
Pellet chemical composition	36
Pellet quality	35, 39
Pellet size	37
Pellet, cold compression	37
Pellet, swelling	38
Pellets, acid	36
Pellets, fluxed	36
Pellets, olivine	36
Permeability and max ΔP	107
Permeability blast furnace	102

Permeability, cohesive zone	137
Permeability, raw materials	102
Permeability and PCI rate	107
Pressure difference	105
Pressure difference and top temperature	106
Pressure taps	230
Primary slag	101, 144
Processing time burden	21
Processing time gas	22
Production rate	183
Productivity	111
Productivity, conditions for high	112
Q_{crack}	71
Raceway structure	12
RAFT, see Flame temperature	
Reduction disintegration	142
Reduction ferrous burden, progress	193
Reduction iron oxides	236
Reduction reactions	142
Reference furnace data	233
Replacement Ratio	71
RIST diagram	250
Rubble ore: see lump ore	
Rules of thumb	234
Scaffolds to furnace wall	212
Scrap, charged in blast furnace	41
Separation hot metal and slag	180
SFCA	33
Silicon	149
Sinter, Al_2O_3	33
Sinter, basicity and productivity	34
Sinter, fluxes and quality	33
Sinter, quality	31
Slag design for stops and starts	158
Slag formation	101
Slag liquidus temperatures	157
Slag liquidus temperatures, basicity, FeO	144
Slag viscosity	156
Slip, mechanism	206
Softening and melting burden	194
Softening and melting burden components	193
Softening ferrous burden	143
SOMA	229
Steel production, global	1

Stockhouse management	200
Stockyard materials	199
Stopping a blast furnace	218
Stops and starts	217
Stove changes and pressure	120
Sulfur	152
Sulfur distribution	154
Symmetry, process	112
Taphole	172
Taphole clay	174
Taphole drilling	176
Taphole face	176
Taphole plugging	175
Temperature profile and reactions	91
Thermal reserve zone	238
Top gas composition, calculation	89
Total energy approach for gas injection	84
Tracking, charge	246
Tuyere blockage by scabs	216
Tuyere failures	213
Tuyere, body burnt	214
Tuyere, nose burnt	214
Tuyere, tipping	215
Utilization, gas	18
Variability charging rate	203
Voidage, creation of	118
Wall working process	127
Water discipline	213
Watergas shift reaction	240
Wind velocity in tuyeres	104
Wustite	17
Zinc	210