

Guide to Building Energy Efficient Homes

In Kentucky and Mixed Humid Climate Zone 4

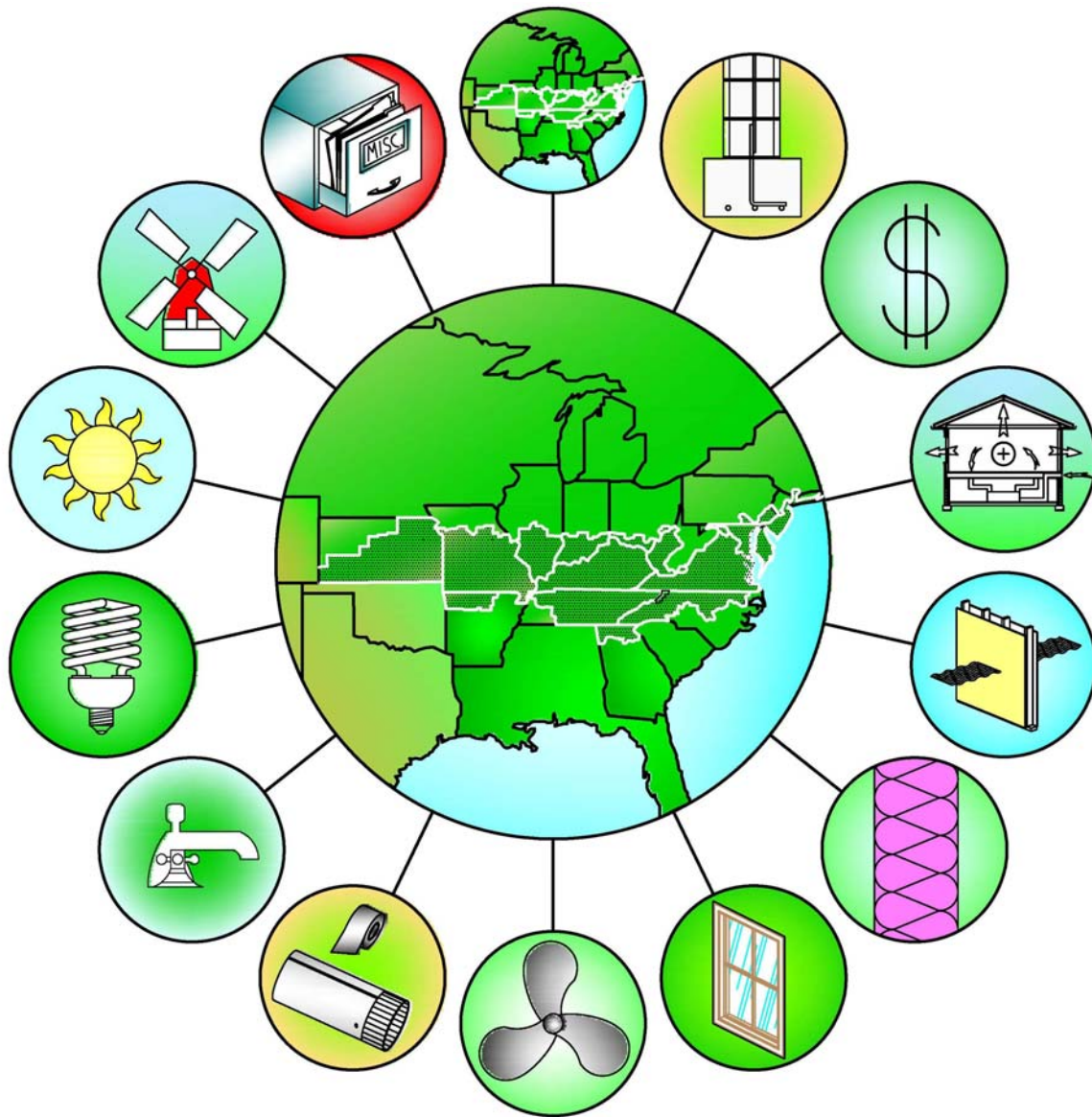

COOPERATIVE
EXTENSION
SERVICE



Biosystems and Agricultural Engineering



Department for Energy Development & Independence

First Edition – May 2009

Principal Author

Robert L. Fehr, Extension Professor
Department of Biosystems and Agricultural Engineering, University of Kentucky

Technical Review

Donald G. Colliver, Professor
Department of Biosystems and Agricultural Engineering, University of Kentucky

William E. Murphy, Professor
Department of Mechanical Engineering, University of Kentucky

Graphics and Desktop Composition

David K. Ash, Linda A. Bach

Research Assistant

William C. Goetz

This publication is based on the *Builder's Guide to High Performance Homes in Kentucky* prepared under contract to the Kentucky Department for Energy Development and Independence, Division of Renewable Energy by Southface.

DISCLAIMER

This publication was prepared with funds made available within the guidelines of U.S. Department of Energy (DOE) Grant No. DE-FG26-06NT42994. However, any opinions, findings, conclusions, or recommendations expressed herein are those of the author(s) and do not necessarily reflect the views of DOE. The contents of this publication are offered as guidance. Neither the Kentucky Department for Energy Development and Independence, Division of Renewable Energy nor University of Kentucky, nor any of their employees, contractors, subcontractors, nor any technical sources referred in this handbook make any warranty or representation, expressed or implied, or assumes any legal liability or responsibility for the accuracy, completeness, or usefulness of any information, apparatus, product, or process disclosed or represents that its use would not infringe on privately owned rights. Reference to any trade names, manufacturer, specific commercial products, process, or service is for information or example only and does not constitute an endorsement or recommendation for use.

Table of Contents

Introduction ix

CHAPTER 1: OVERVIEW OF ENERGY EFFICIENT CONSTRUCTION 1

 Energy Efficient Homes: The Key Components and Their Features 2

 Air Barrier System 2

 Moisture Barrier System 2

 Continuous Insulation System 2

 Energy Efficient Framing 2

 Energy Efficient Windows and Doors 3

 Energy Efficient Heating and Cooling Systems 3

 Passive Radon System 3

 Energy Efficient Ductwork 3

 Water Heating 3

 Energy Efficient Appliances and Lighting 4

 Overall Site Planning 4

 Four Home Designs that Incorporate Energy Efficient Features 6

CHAPTER 2: ENERGY RATINGS AND ECONOMICS 11

 2006 International Residential Code 12

 Home Energy Rating System (HERS) and ENERGY STAR® 13

 Builder Option Package 13

 Home Energy Rating Software 14

 Beyond ENERGY STAR® 14

 Economics of Energy Efficient Houses 15

 Break-even Investment 15

 Energy Efficiency Incentives and Financing 19

CHAPTER 3: THE HOUSE AS A SYSTEM.....	21
Household Environment	22
Things to Know - Basic Concepts	23
How Heat Moves in Homes	23
How Air Moves in Homes	24
How Moisture Moves in Homes	27
Relative Humidity.....	29
Effect of Relative Humidity	32
Systems in a House	33
Structural System.....	33
Thermal Insulation System	33
Air Leakage Control System	34
Moisture Control System	37
Comfort Control System Provided by the HVAC System	37
Three Problems Involving Various Systems	39
Moisture Problem Example	39
Wall Moisture Example.....	40
Carbon Monoxide Disaster	42
CHAPTER 4: AIR LEAKAGE CONTROL: MATERIALS AND TECHNIQUES	43
Overview	44
Seal Framing.....	44
Housewraps	46
Seal Penetrations And Bypasses	47
Weatherstripping.....	53
Airtight Recessed Lights	53
Airtight Drywall Approach	54

ADA Advantages.....	54
ADA Disadvantages	55
ADA Installation Techniques	55
Measuring Airtightness	56
CHAPTER 5: INSULATION: MATERIALS AND TECHNIQUES.....	59
Insulation Materials	60
Fiber Insulation	60
Foams.....	60
Insulation and the Environment	60
Insulation Strategies	61
Foundation Insulation	62
Insulating Under Floors.....	70
Insulating Walls.....	71
Ceilings and Roofs	78
CHAPTER 6: WINDOWS AND DOORS	89
Windows	90
Low-Emissivity Coatings.....	90
Inert Gas Fills.....	92
Solar Heat Gain Coefficient.....	92
Multiple Panes	93
Window Recommendations for Climate Zone 4.....	93
The Problem of Reporting Window Insulating Values.....	95
Benefits of ENERGY STAR® Rated Windows	97
Proper Window Installation	98
Future Window Options.....	98
Windows and Natural Ventilation.....	98

Windows and Shading	99
Doors.....	101
Accessible Design.....	102
CHAPTER 7: HEATING, VENTILATION, AIR CONDITIONING (HVAC).....	103
Types of Heating Systems	104
Forced-Air System Components	104
Radiant Heating Systems	105
Heat Pump Equipment.....	105
Furnace Equipment.....	109
Air Conditioning	113
Air Conditioners	114
The SEER Rating	115
HVAC Systems	116
Sizing	116
Temperature Controls	118
Zoned HVAC Systems.....	118
Cooling Equipment Selection.....	120
Ventilation And Indoor Air Quality	121
Supplying Outside Air from Air Leaks	123
Supplying Outside Air from Inlet Vents	124
Supplying Outside Air via Ducted Make-up Air.....	124
Dehumidification-Ventilation Systems	124
Heat Recovery Ventilators	125
Sample Ventilation Plans	126
Radon.....	129
Removing Radon.....	129

CHAPTER 8: DUCT DESIGN AND SEALING	131
Duct Leaks and Air Leakage	132
Testing for Duct Leakage.....	132
Sealing Air Distribution Systems	134
High Priority Leaks	135
Moderate Priority Leaks.....	137
Low Priority Leaks	138
Duct Design	140
Duct Materials.....	140
Sizing and Layout	141
CHAPTER 9: WATER HEATING	145
Energy Conservation for Water Heating.....	146
Gas Water Heaters.....	147
Electric Water Heaters	148
Heat Recovery Units.....	148
Solar Water Heaters.....	149
On Demand Water Heaters	149
CHAPTER 10: APPLIANCES AND LIGHTING.....	151
Energy Efficient Appliances.....	152
ENERGY STAR® Appliances	153
Lighting.....	153
ENERGY STAR® Advanced Lighting Package.....	155
Recessed Lights	156
Solar Tubes.....	157
CHAPTER 11: PASSIVE SOLAR HOMES	159
Basic Design Guidelines	160

Passive Solar Components 162

 Passive Solar Windows 162

Proper Design 162

Thermal Storage Mass 164

 Problems Without Thermal Storage Mass..... 166

 Thermal Mass Patterns 168

 Design Options for Thermal Mass 169

Heat Distribution 169

Estimating Passive Solar Saving 170

Design for Summer and Winter 170

CHAPTER 12: ALTERNATIVE TECHNOLOGIES 171

 Solar Hot Water 172

 Active Systems 172

 Passive Systems 174

 Design Considerations 174

 Photovoltaic Panels 175

 Design Considerations 176

APPENDIX: FINGER TIP FACTS 177

 Glossary..... 178

 Energy and Fuel Data 203

 Energy Units..... 203

 Power Units..... 203

 Fuel Units 203

 Climatic Data 204

INTRODUCTION

The purpose of this guide is to give a basic understanding of the building science fundamentals necessary to construct energy efficient homes. The target audience for this guide is anyone interested in understanding the building science fundamentals of energy efficient homes.

This guide focuses on the “what to do” and “why to do it” aspects of constructing energy efficient homes and provides only limited “how to do it” details. While the details of “how to do it” are essential to the proper actual construction, they are more complex and specialized in nature than can be covered in a general guide.

Examples are provided to give some idea of savings available from various energy efficient construction techniques; however, construction costs associated with those techniques are not included due to the wide variation and variability of these costs.

This guide was specifically targeted to the moist section of Climate Zone 4, shown on the figure below, often referred to as Mixed Humid. While the building science fundamentals would be the same anywhere, the recommendations and examples in this guide are for the moist section of Climate Zone 4 and use in other climate zones should be done with caution.

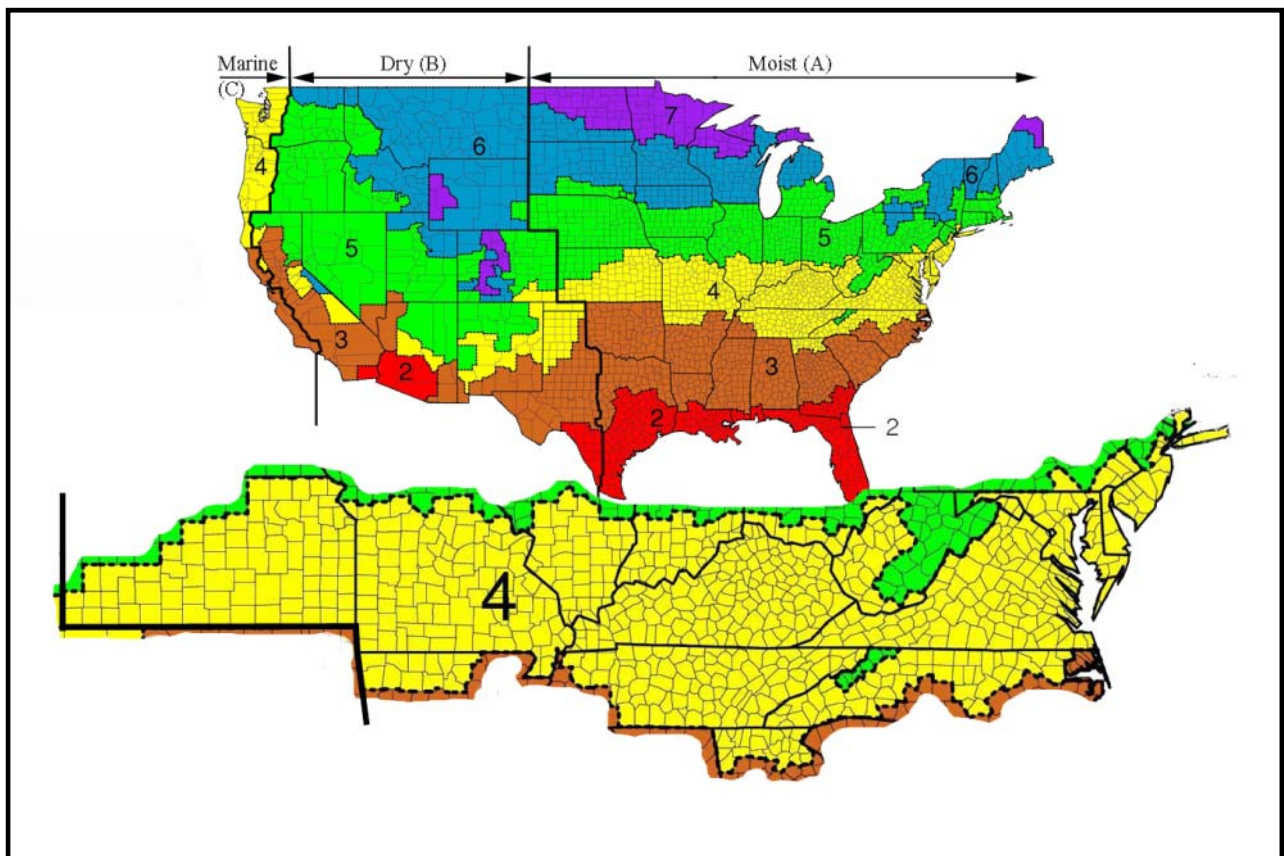



ENERGY EFFICIENT HOMES: THE KEY COMPONENTS AND THEIR FEATURES

AIR BARRIER SYSTEM (CHAPTER 4)

An *air barrier system* eliminates leakage between conditioned and unconditioned spaces.

- Seal all openings between living areas and crawl spaces, unheated basements, attics, and garages

MOISTURE BARRIER SYSTEM (CHAPTER 4)

An effective *moisture barrier system* keeps bulk (free) moisture from wood framing and interior of home.

- Drain water away from the foundation
- Install capillary breaks
- Use 6 mil polyethylene ground cover
- Carefully flash roof details, around windows and doors, and over other roof and wall penetrations through which wind-driven rain may leak

CONTINUOUS INSULATION SYSTEM (CHAPTER 5)

A *continuous insulation system* creates as unbroken an insulation layer as possible between conditioned and unconditioned spaces, such as:

- Foundation walls, exterior framed walls, floors over unconditioned or exterior spaces, ceilings below unconditioned or exterior spaces (including attic access covers)
- Wall areas adjacent to attic spaces or basement spaces, such as knee walls, attic stairways, and high interior walls with attic or exterior space
- Behind wall areas between conditioned and unconditioned spaces, such as band joists, garage walls, basement stairways, and mechanical room walls

ENERGY EFFICIENT FRAMING (CHAPTER 5)

Energy efficient framing reduces thermal bridging by using fewer solid members in the walls to increase the overall R-value of the wall.

- Use advanced framing techniques
- Use insulated headers

ENERGY EFFICIENT WINDOWS AND DOORS (CHAPTER 6)

Energy efficient windows and doors must be properly located and installed.

- Design home with minimal east and west glass area
- Locate additional glass area on south side for passive heating in winter months
- Consider passive solar designs to further reduce heating needs
- Use double-paned windows with low-emissivity coatings and other high performance features (U-factors less than 0.35)
- Shade windows in summertime with overhangs or glazing treatments

ENERGY EFFICIENT HEATING AND COOLING SYSTEMS (CHAPTER 7)

Energy efficient heating and cooling systems utilize high efficiency equipment designed for the local climate. These systems must be both properly sized and installed.

- Locate equipment in conditioned spaces
- Use sealed combustion devices to eliminate potential for backdrafting

PASSIVE RADON SYSTEM (CHAPTER 7)

Install a *passive radon system* to minimize expenses of a potential problem. Radon is a cancer-causing, radioactive gas.

- Cost of converting a passive system to an active system is much less than having to install an entire radon mitigation system

ENERGY EFFICIENT DUCTWORK (CHAPTER 8)

Energy efficient ductwork supplies proper airflow to provide adequate comfort conditioning if the size and layout of the ductwork are correct.

- Measure airflow to guarantee balance and comfort
- Locate ductwork in conditioned spaces
- Seal all duct leaks, except those in removable components, with mastic or mastic plus fiber mesh; seal leaks around removable components with tape having UL-181 A or B rating
- Have ductwork pressure tested for tightness
- Reduce the amount of flexible ductwork and make sure it does not have sharp bends

WATER HEATING (CHAPTER 9)

Saving energy, while *heating water*, requires selection of efficient equipment.

- Use heat traps to prevent convective loops
- Install water heater wraps
- Install energy efficient water heaters
- Use hot water conserving fixtures and appliances



ENERGY EFFICIENT APPLIANCES AND LIGHTING (CHAPTER 10)

Energy efficient appliances and lighting reduce a home's operating costs.

- Install fluorescent or compact fluorescent lamps, if operating for more than 4 hours per day
- Use recessed lighting fixtures selectively. Choose only insulation contact (IC) rated lighting fixtures
- Use high-pressure sodium or metal halide lamps for exterior lighting (daylight sensors needed if used for security lighting)
- Select ENERGY STAR® rated appliances

OVERALL SITE PLANNING

To enhance the energy efficiency of a home that incorporates these key components, the home must also be located properly on the lot to best utilize the environment. Landscaping is added and used to full advantage. Figure 1-1 contains general site planning and landscaping guidelines that will aid in creating an energy efficient home. Builders have limited options about the orientation of a home on most building lots; therefore, the developer must consider home orientation when planning a subdivision. Builders can modify house plans, to some extent, to ensure that glassed areas are properly located with the majority of the glassed areas being oriented within 20 degrees of south.

In Figure 1-1, the length of the house (with many glass windows) faces south in order to take advantage of the winter sunlight. The following eight general site planning and landscaping guidelines can be located in Figure 1-1.

Site planning and landscaping guidelines include:

1. Major glassed areas are oriented to the south within 20 degrees; overhangs provide summer shade, but do not block winter sunlight.
2. A garage to the west blocks summer sun and winter winds.
3. Deciduous trees shade east, west, southeast, southwest, and northeast sides in the summer.
4. A windbreak of evergreen trees and shrubs to the north will buffer winter winds.
5. A trellis, with deciduous vines, shades the east wall. Windows should be limited on the east side, which receives early morning sun.
6. Ground cover reduces reflected sunlight.
7. Gutter systems direct water away from the foundation.
8. Water is removed from the foundation, using a continuous foundation drain in a gravel bed, with a fabric filter connected.

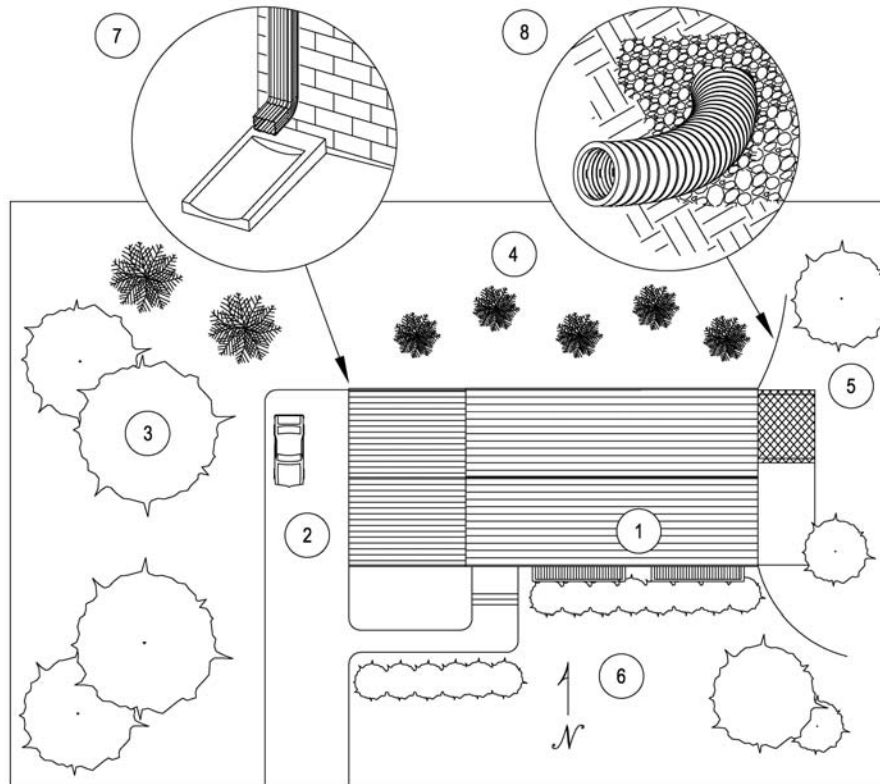

Figure 1-1 General Site Planning and Landscaping Guidelines

FOUR HOME DESIGNS THAT INCORPORATE ENERGY EFFICIENT FEATURES

The following four home cross-sections show how the key components of energy efficient home construction can be adapted to a number of basic homes. These components can be mixed in various combinations to achieve an energy efficient home.

Figure 1-2 shows a two-story home cross-section with a conditioned basement. The attic is not used for storage or HVAC. Attic access is only provided to locate a roof leak. HVAC is provided to the second floor by the use of a duct chase from the basement through the floor trusses on the second floor that contain the duct system. The HVAC system can be located any place, other than the attic, in this cross-section.

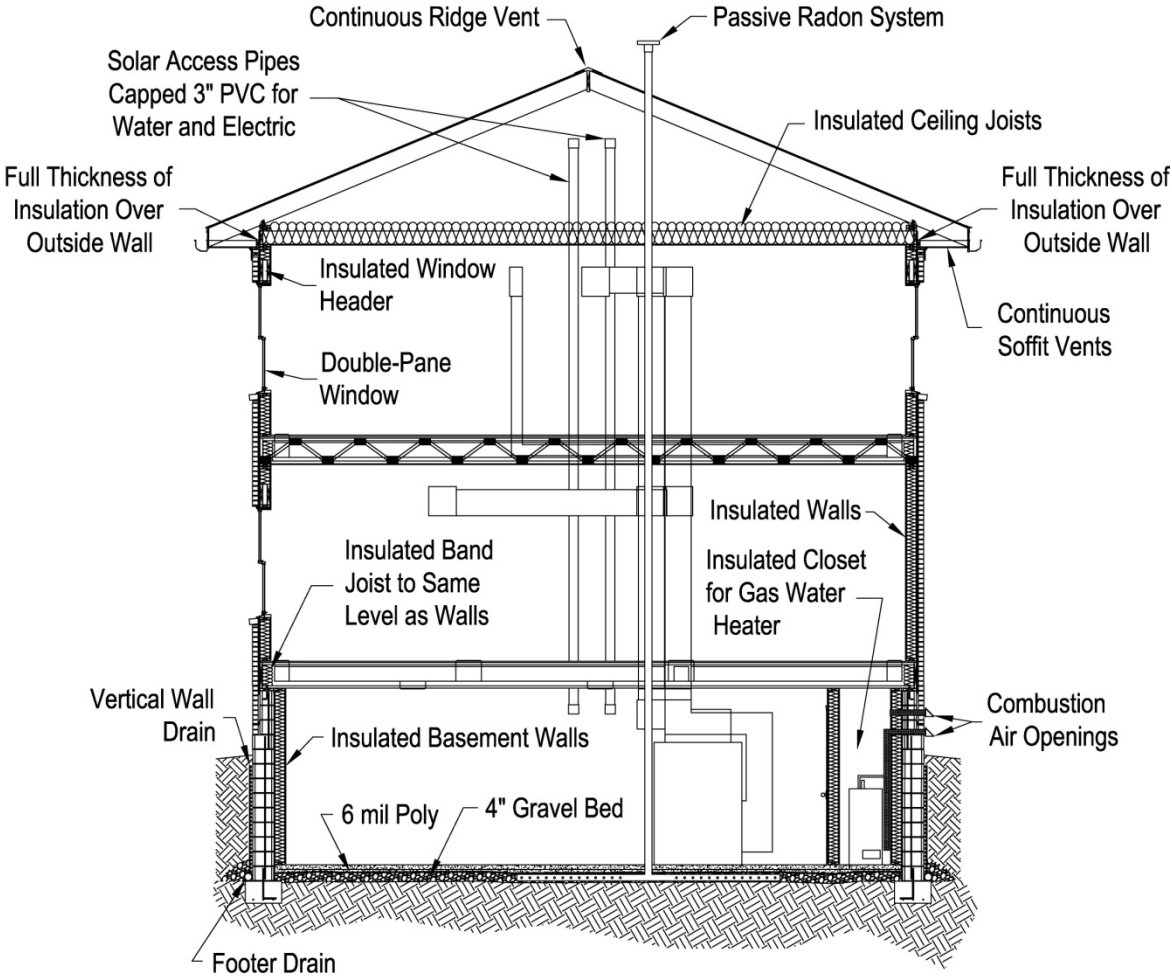

Figure 1 – 2 Two-story Home Cross-section with a Conditioned Basement, No Attic Use

Figure 1-3 shows a two-story home cross-section with a conditioned mini-basement (crawl space) that uses the attic for HVAC and storage. To keep the HVAC system in a conditioned space, the rafters are insulated. The attic is now considered to be within the insulated envelope of the home. The ceiling joists *must* be designed to support the additional load and vibration of the HVAC system and to support any storage load.

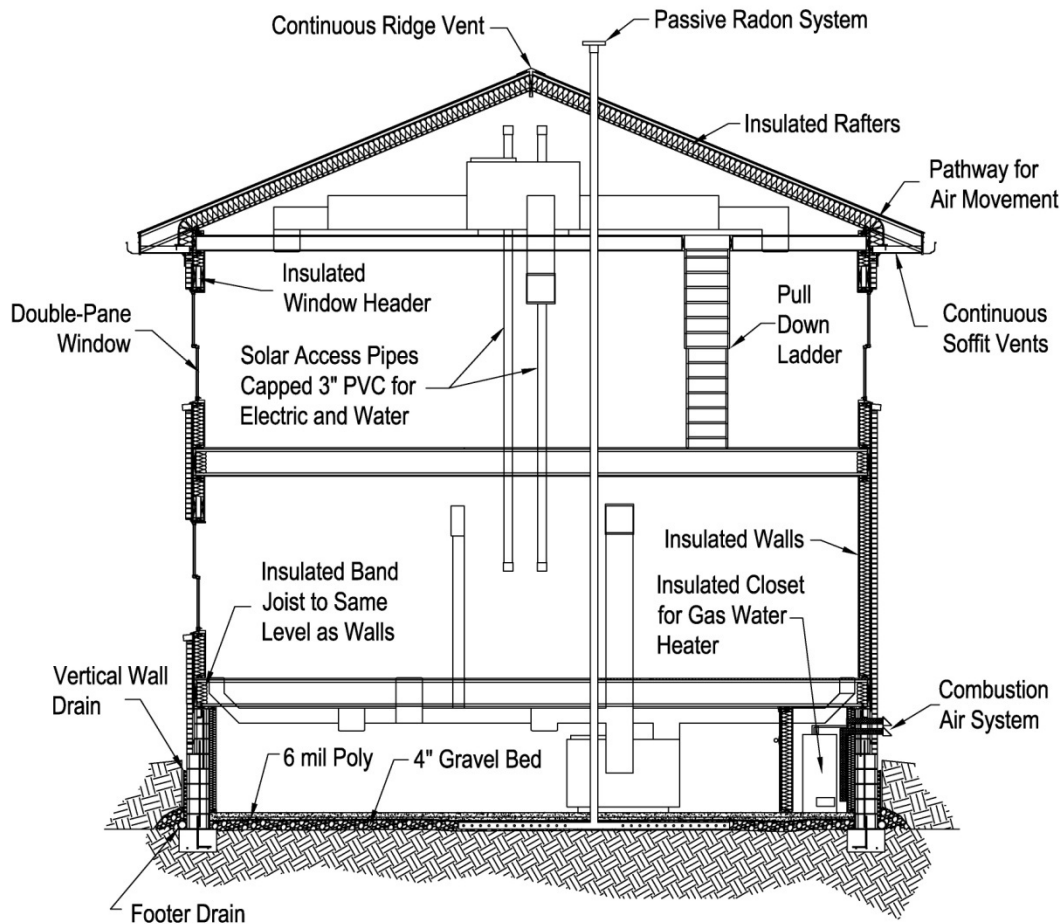

Figure 1 – 3 Two-story Home Cross-section with a Conditioned Mini-Basement (Crawl Space); Attic used for HVAC and Storage

Figure 1-4 shows a two-story home cross-section with a vented crawl space, insulated floor and unconditioned attic storage. The HVAC system must be in a conditioned space. In this example, because the ceiling is insulated, the HVAC is located on the first floor. This design requires the use of floor trusses on the second floor for the duct system and utilizes the crawl space for the first floor duct system. Because the first floor ducts are not within the building envelope, it is important that they be insulated and sealed. Ceiling trusses must be designed to handle the storage load and be high enough to prevent the compression of the insulation.

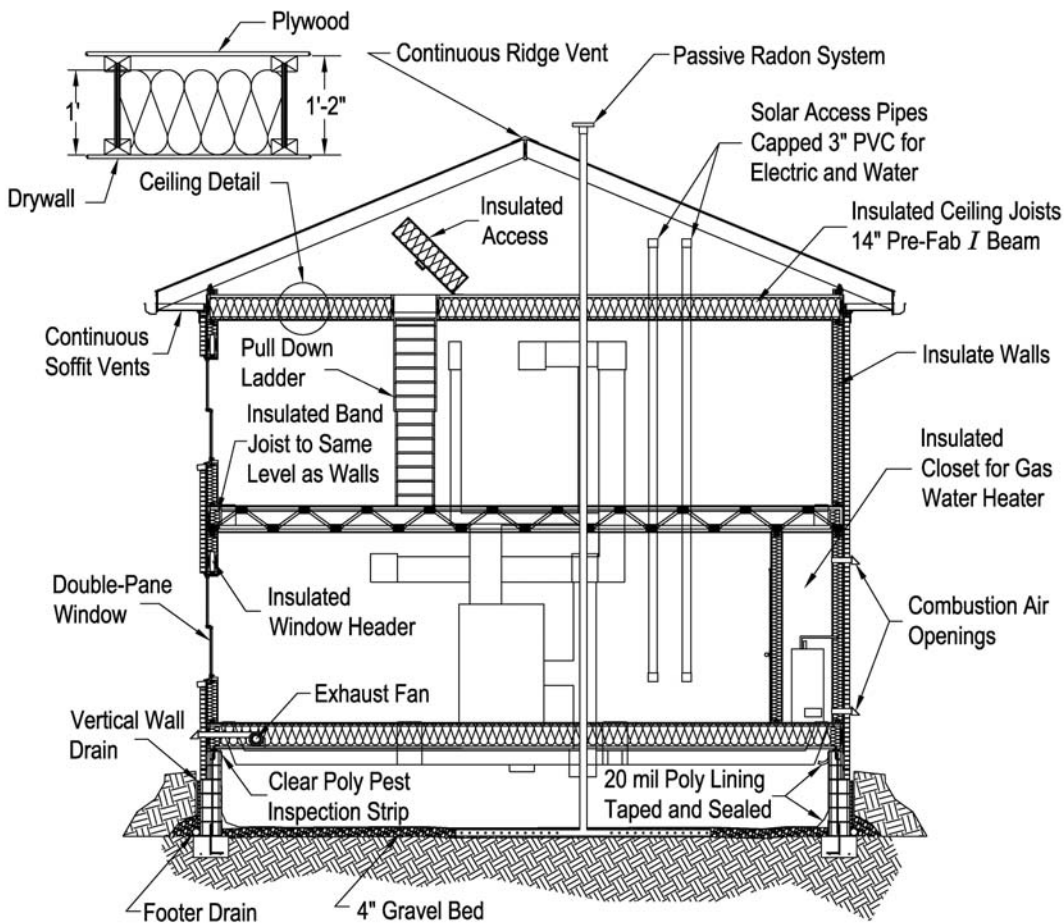

Figure 1 – 4 Two-story Home Cross-section with a Crawl Space; Attic Storage

Figure 1-5 shows a two-story home cross-section with a slab floor. The attic is not used for storage or HVAC. This design is more difficult for a single story home. The HVAC equipment can be located in the insulated envelope of the building; however, keeping the duct system in the envelope takes planning. Recommendations for the design and installation of ducts in unconditioned areas are discussed in Chapter 8.

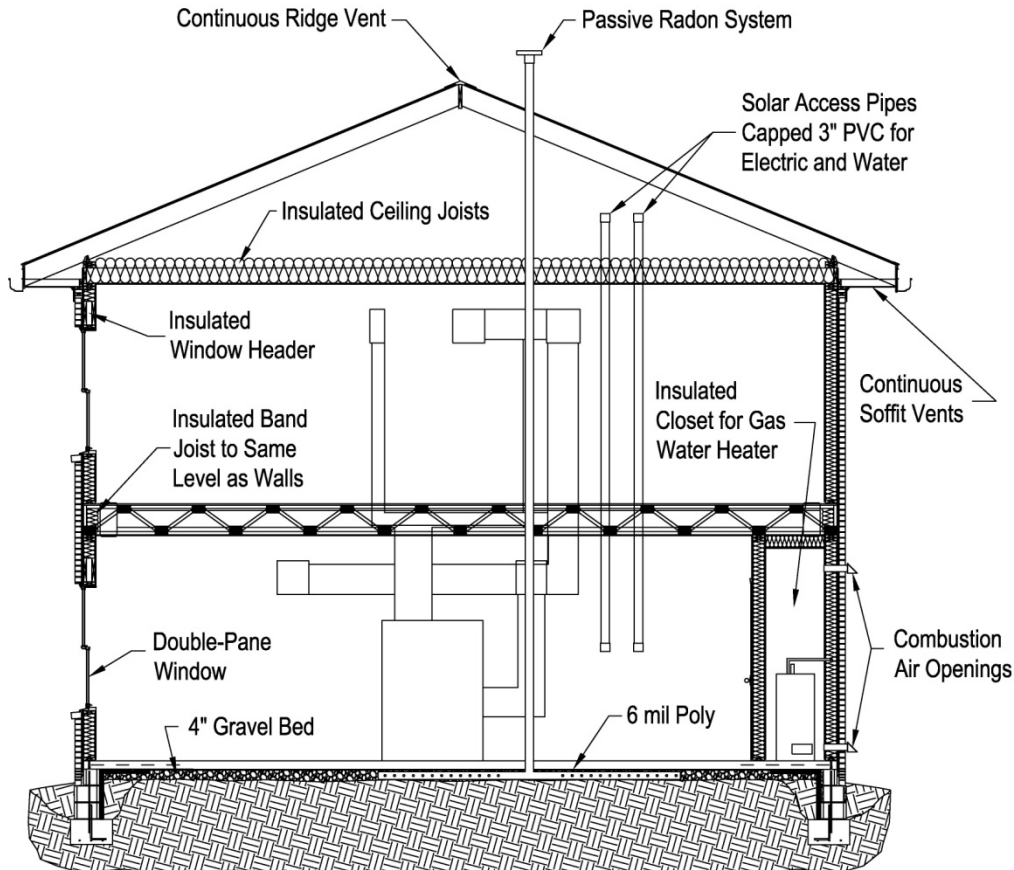
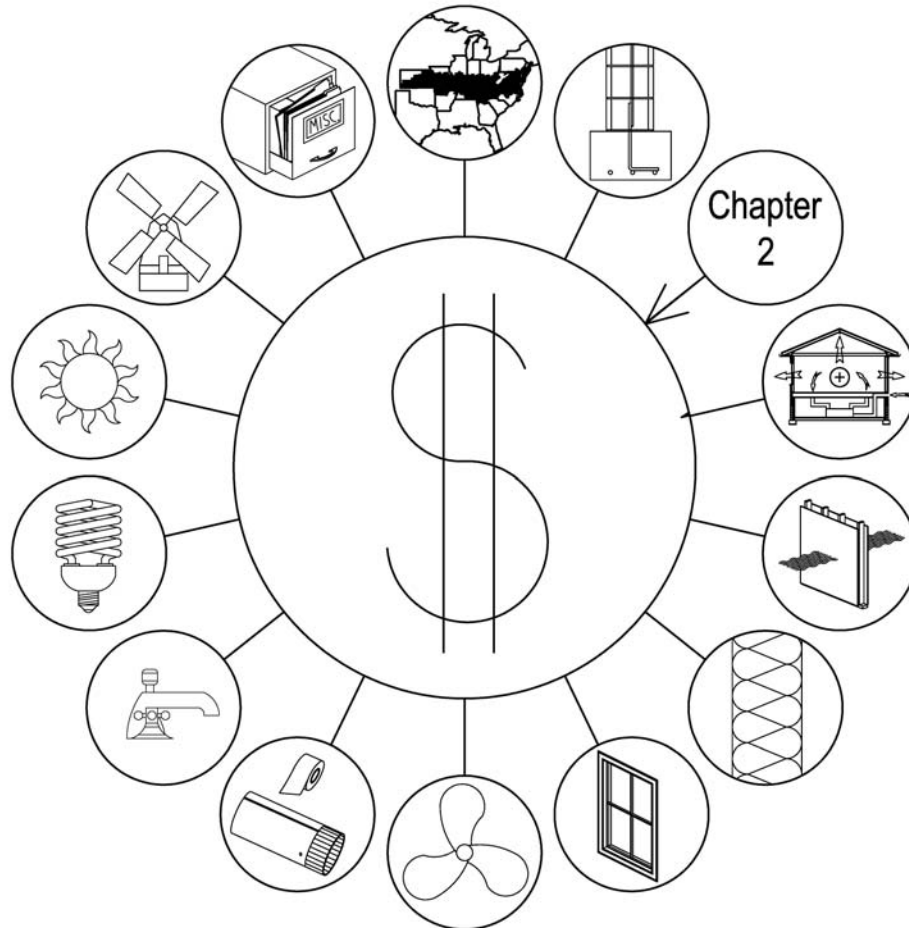

Figure 1 – 5 Two-story Home Cross-section on a Slab; No Attic Use

CHAPTER 2: ENERGY RATINGS AND ECONOMICS

Certainly, a homeowner's habits, values and customs affect energy consumption. Construction of a dwelling that incorporates model building codes and utilizes energy efficient construction methods will dovetail nicely with the homeowner's desire for a satisfying, yet energy efficient home. Building energy efficient homes requires no special materials or construction skills. Chapter 2 examines the 2006 International Residential Code and ENERGY STAR® guidelines, with an additional emphasis on the economics of building energy efficient homes.



2006 INTERNATIONAL RESIDENTIAL CODE
--

The 2006 International Residential Code (IRC) is being considered for adoption in a number of states. The IRC is a model building code that states may adopt as their building code. Most states include locality specific addendums to the code when it is adopted. This book references the 2006 IRC without addendums. It is the responsibility of a builder to ensure that a home meets the state or local jurisdiction's specific building code. The IRC references the International Energy Conservation Code, IECC, for details on meeting the energy section of the IRC. The insulation requirements of the energy code for Climate Zone 4 are shown in Table 2-1. All of Kentucky is in Climate Zone 4. In order to simplify code compliance, the Pacific Northwest National Laboratory, funded by the U.S. Department of Energy, has developed REScheck, easy-to-use software that allows the home designer great design flexibility. Tradeoffs can be made between areas with too little insulation and those that exceed the code. The REScheck software assumes full compliance with the 2006 IRC when calculating tradeoffs. Software used to calculate a Home Energy Rating System (HERS) score for ENERGY STAR® certification can also be used to determine full code compliance.

Table 2-1 Insulation and Fenestration Prescriptive Requirements by Component from the 2006 IRC for Climate Zone 4 (except Marine)

Component	Requirement
Fenestration	U – 0.40 (U – 0.48 maximum allowed for performance-based compliance)
Skylight	U – 0.60 (the Fenestration U-factor excludes skylights)
Fenestration SHGC	Not required in Climate Zone 4
Ceiling	R – 38 (R – 30 satisfies the requirement if the insulation is uncompressed, full height, to the wall top plate at the eaves)
Ceilings without Attic Spaces	R – 30 required, limited to 500 sq ft of ceiling
Wood Frame Wall	R – 13
Mass Wall	R – 5 (50% must be on the exterior or integral to the wall)
Floor	R – 19
Basement Wall	R – 10 continuous/R – 13 framing cavity
Slab	R – 10, 2 ft deep, oriented vertically or horizontally
Crawl Space Wall	R – 10 continuous/R – 13 framing cavity
Fenestration U-factor	Area weighted average of fenestration products can satisfy requirement
Opaque Door	Exempted from Fenestration U-factor
Recessed Lighting	Luminaries installed in the thermal envelope shall be sealed to limit air leakage; air tight Insulation Contact (IC) rated fixtures that are labeled as meeting ASTM E283
Ducts	Minimum of R – 8 in unconditioned space/minimum of R – 6 in floor trusses

Energy efficient homes are no accident. Too often, building aspects that may be easier to market are installed, while key building components, such as sealing air leaks and duct leaks, are left unattended. As a result, new homes often fall far short of the goals of a true high performance home; energy bills are higher than necessary, comfort and moisture problems abound, and homeowners are thoroughly dissatisfied.

Energy efficient homes require no special materials or construction skills other than attention to details. The following basic construction components have a major influence on moisture control, building comfort and energy costs.

- The quality of framing and proper installation of insulating materials and windows;
- The degree of thoroughness in installing ground covers, window flashing, door seals, roof detailing, and other moisture controls;
- Attention to detail in sealing air leaks;
- Design and installation of the heating and cooling equipment; and
- Effectiveness of sealing ducts.

HOME ENERGY RATING SYSTEM (HERS) AND ENERGY STAR®

The Home Energy Rating System (HERS) is a national effort to train and certify home energy raters. The HERS raters determine whether homes meet ENERGY STAR® guidelines. In order to qualify for ENERGY STAR®, a home must qualify under third-party certification by a Home Energy Rater. There are a number of Home Energy Raters in Kentucky who can provide this service.

The home energy rater inspects the home on several different occasions and determines its energy use characteristics, such as insulation levels, window efficiency, window-to-wall ratios, heating and cooling system efficiency, solar orientation of the home, and water heating system efficiency. Diagnostic testing, including air leakage and duct leakage testing, and a thermal bypass check are all part of the inspection process. After the home energy inspection, there are two basic paths to achieving an ENERGY STAR® rating. The one path uses the Builder Option Package for Climate Zone 4. The other path requires the home energy rater to enter data into a computer program to evaluate the home.

BUILDER OPTION PACKAGE

The U.S. Environmental Protection Agency/U.S. Department of Energy web site on features of ENERGY STAR® Qualified Homes: National Builder Option Package lists the insulation and window characteristics necessary to be an ENERGY STAR® qualified home. If the insulation and window characteristics meet these standards, the home can qualify as ENERGY STAR® as long as it also meets the performance requirements. The three performance requirements are:

1. The air leakage rate, as tested and confirmed by an independent blower door test, does not exceed 0.35 natural air changes per hour (ACHnat).
2. The duct leakage rate, as tested and confirmed by an independent duct leakage test, does not exceed 4 cubic feet per minute (cfm) to the outdoors per 100 square feet (sq ft) conditioned floor space.
3. The house passes the thermal bypass inspection checklist (consult the government web site for ENERGY STAR® Qualified Homes: Thermal Bypass Inspection Checklist for specifics).

HOME ENERGY RATING SOFTWARE

If the home does *not* qualify for the ENERGY STAR® rating utilizing the Builder Option Package, the home energy rater can enter the data for the home into a computer program that provides ratings. The software evaluates the energy features of the home and calculates a home energy rating, based on its relative efficiency. The software also estimates the home's energy costs.

The home energy rating is the key factor in determining whether the home qualifies as ENERGY STAR®. Current home energy ratings are:

- A rating of 100 means that the home meets the 2004 International Energy Conservation Code (IECC).
- A rating of 85 or lower is required for ENERGY STAR® certification in Climate Zone 4.

Under the new HERS, the energy efficiency of a home is compared to an identical computer-simulated reference house that *only* meets the minimum requirements of the 2006 International Energy Conservation Code (IECC). The calculated HERS rate is indexed, with the reference house assigned a score of 100 and a net-zero energy house assigned a score of zero. Each 1% reduction in energy usage results in a one point decrease in the HERS Index. Thus, an ENERGY STAR® qualified home, in Climate Zone 4, must have a HERS Index of 85 or lower, and therefore is required to be 15% more energy efficient than the 2006 IECC.

Home energy rating is also a major component in green builders' programs. In addition to energy efficiency, these programs address other environmental concerns regarding home construction practices, such as materials conservation, water efficiency, land preservation, waste management, and indoor air quality.

In addition to verifying compliance with ENERGY STAR®, home energy ratings offer other benefits, such as:

- Verification of home quality;
- An estimate of annual energy costs;
- A design process tool to choose energy features;
- A nationally-approved scoring system that allows home buyers to compare energy efficiency of homes;
- Added value that increases the appraised value;
- A compliance tool for the Kentucky Residential Energy Code;
- A home certification for ENERGY STAR® and other programs; and
- A home certification for energy efficient mortgages (see later section of Chapter 2).

BEYOND ENERGY STAR®

Most energy experts agree that ENERGY STAR® homes are only a starting point for energy efficiency in new residences.

One of its most important contributions, in addition to its groundbreaking marketing innovations, is the requirement for testing air leakage and duct leakage. The energy code can dictate efficiency levels for insulation, windows, and HVAC systems, but cannot, in the foreseeable future, require all homes to have

leakage testing. Unfortunately, many new homes suffer from air and duct leakage problems, which are virtually undetectable without testing.

For builders or homeowners wishing to exceed ENERGY STAR®, there are multitudes of options that provide cost effective savings. A typical package of measures would include:

- Higher efficiency walls using 2x6 construction, insulated concrete forms, or structural insulated panels, all discussed in Chapter 5;
- All ductwork located within the conditioned space;
- Airtight drywall approach or other air sealing system, discussed in Chapter 4;
- High efficiency HVAC systems, with condensing furnaces having efficiencies greater than Annual Fuel Utilization Efficiency (AFUE) of 90%, air conditioners with a Seasonal Energy Efficiency Rating (SEER) of 15 or over, heat pumps with a Heating Season Performance Factor (HSPF) over 8.2, or geothermal heat pumps (see Chapter 7);
- Heat recovery ventilation systems; and
- High efficiency water heaters, lighting, and appliances.

ECONOMICS OF ENERGY EFFICIENT HOUSES

Investments in energy efficient improvements in new construction are remarkable because everyone wins.

- Homeowners receive an economic benefit over the life of the loan.
- Homeowners benefit additionally from improved comfort, better indoor air quality, reduced moisture problems, and fewer health problems.
- Builders have fewer call-backs and make additional profits from the added value of the home.
- Heating and cooling contractors have fewer call-backs.
- Realtors earn additional fees from the value-added features and enhance their reputation by selling higher quality homes that consumers appreciate.
- Some lending agencies offer preferred financing options to owners of energy efficient homes.
- The local economy benefits as more money stays within the community; local subcontractors and product suppliers earn additional income by selling improved energy efficient features.
- Everyone benefits from reduced air pollutant emissions from fossil-fuel power plants.

BREAK-EVEN INVESTMENT

The objective of energy investments is to provide a positive cash flow to the homeowner. Energy investments require calculations, frequently called life-cycle investment calculations. These calculations include the cost of homeownership: the initial cost and the expected future operating costs, maintenance, and component replacement costs. A break-even investment is the amount that can be invested in energy saving techniques such that the cost of the additional mortgage payment is equal to the energy savings.

In the short term, a break-even investment does not consider future energy price increases; the homeowner immediately sees savings or no increased cost of ownership. In the long term, a life-cycle investment calculation considers the life of the building components, accounts for future energy price increases and projects what the homeowner will see in savings over time.

An analysis of energy efficient houses is most beneficial when a long-term approach is used; however, this requires time and resources to do properly. For example, if considering a life-cycle analysis, the cost of a more efficient HVAC system compared to 2x6 walls would have to include the expected life of the HVAC unit, while 2x6 walls could be expected to have a life equal to the life of the house.

The graph shown in Figure 2-1 displays the concept of a break-even investment to define the point at which the additional mortgage cost equals the savings on utility costs. The amount of the additional loan that is represented by the additional mortgage cost is then the break-even investment. While the potential savings in utility bills can be determined for a number of energy saving techniques (and therefore, the break-even investment), the additional construction costs associated with these techniques are difficult to calculate because builders often have unique situations that can affect these costs.

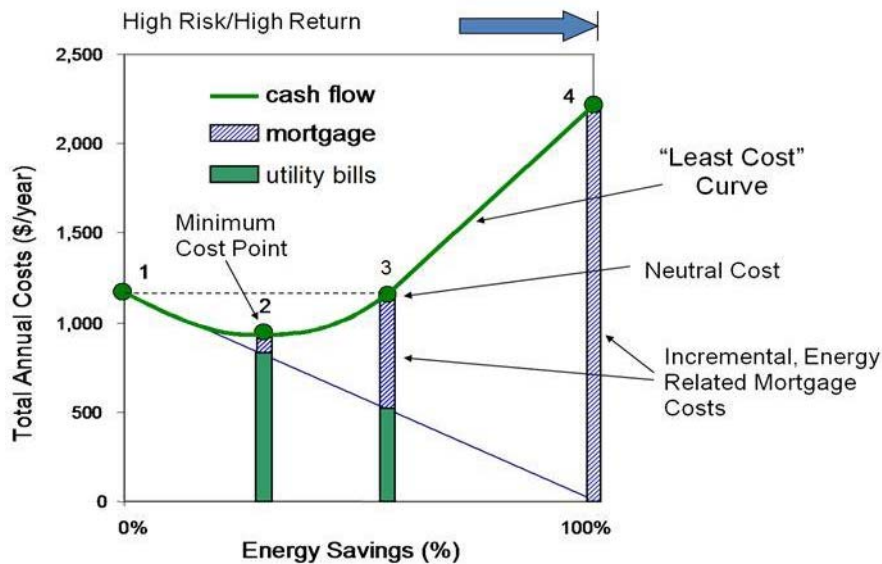

Figure 2 - 1 Economics of Energy Efficient Homes

To evaluate the potential savings of reducing a home’s energy usage by 15% (ENERGY STAR® level 85) or exceeding ENERGY STAR® to a 30% reduction in energy usage (ENERGY STAR® level 70), a sample 2,000 square foot house has been developed. In addition to these two energy efficient packages, a geothermal HVAC system, installed in the home that exceeds ENERGY STAR® to a 30% reduction, was also evaluated. Table 2-2 shows the heating and cooling energy savings for four separate homes. The Code Home just meets the standards of the 2006 IECC, while the other three homes were designed to exceed the energy savings of the sample home. The Code Home only utilizes basic energy efficiency improvements. The ENERGY STAR® Home package includes a set of energy efficient construction features that exceed the 2006 IECC and provide an excellent return on investment. The Home That Exceeds the characteristics of an ENERGY STAR® Home incorporates additional features to further reduce heating, cooling, and hot water requirements. The final home, the Geothermal Home, shows the potential savings with a highly efficient HVAC system.

As seen in Table 2-2, an ENERGY STAR® Home would allow an owner to assume an additional \$3,080 on a 30-year mortgage without a net increase in total annual payments for the mortgage plus energy costs.

Table 2-2 Economic Analysis of Energy Efficient Packages				
	Code Home¹ HERS=98	ENERGY STAR® Home² HERS=85	Exceeds ENERGY STAR® Home³ HERS=70	Geothermal Home⁴ HERS=56
Annual Energy Costs				
Heating	\$563	\$371	\$278	\$143
Cooling	\$167	\$156	\$110	\$94
Hot Water	\$286	\$286	\$286	\$226
Lighting/Appliances	\$517	\$517	\$470	\$470
Service Charges	\$96	\$96	\$96	\$96
Total Annual Energy Costs	\$1,629	\$1,426	\$1,240	\$1,029
Annual Energy Savings⁵				
		\$203	\$389	\$600
Equipment Size Heating/Cooling (MBtu)				
	52.3/31.7	38.8/25.7	25.7/19.8	25.7/19.8
Break-even Investment⁵ ‡ (8% loan for 30 years)				
		\$3,080	\$5,903	\$9,105
¹ A two-story, 2,000 sq ft home in Lexington, KY, exactly meeting the 2006 International Energy Conservation Code. ² ENERGY STAR® Home is approximately 15% more efficient than a Code Home: better windows, less duct loss, less infiltration. ³ Exceeds ENERGY STAR® Home has additional efficiency features to be approximately 30% more efficient than a Code Home: better wall insulation, less window area, ENERGY STAR® rated heat pump. ⁴ Geothermal Home was modeled by using a geothermal heat pump in the Exceeds ENERGY STAR® Home. ⁵ Compared to Code Home. ‡ See Chapter 2 for information on break-even investment.				

It is important to understand that envelope improvements, such as insulation are additive. The savings from improved heating and cooling system efficiency added to envelope improvement are different. For example, if a geothermal system had been used with the Code Home in Table 2-2, the annual savings would have been \$394, see Table 2-3. The savings by envelope improvements to an ENERGY STAR® home is \$203. However, the total savings by both envelope improvement and adding geothermal is \$508 or \$89 less than \$597, the sum of \$394 plus \$203.

Table 2-3 Energy Savings from Upgrading HVAC Efficiency and Envelope Improvements

Home	Annual Energy Cost	Savings Compared to Code Home	Upgrade
Code	\$1,629		
Code w/geothermal	\$1,235	\$394	HVAC Efficiency
ENERGY STAR [®]	\$1,426	\$203	Envelope Improvements
ENERGY STAR [®] w/geothermal	\$1,121	\$508	Both HVAC & Envelope



Remember that the investment in insulation, more efficient windows, and sealing air and duct leaks will reduce the required size of the HVAC system.

Smaller HVAC systems reduce the initial cost and require a smaller duct system. Too often, builders do not obtain the resulting savings in costs because their HVAC contractors size HVAC systems using rules of thumb rather than calculations based on the characteristics of the home (see Chapter 7).

The addition of energy saving techniques is also governed by the law of diminishing returns; each additional improvement to a specific area results in less savings than the previous improvement. Figure 2-2 shows the annual energy costs for different levels of ceiling insulation used with the Code Home in Table 2-2. Ceiling insulation levels are unique from most other energy savings techniques because, if a blown insulation product is used, then any R-value can be added. Therefore, a builder can select any level that meets or exceeds code. The cost of additional ceiling insulation is also unique because many of the installation contractor’s costs are fixed, such as travel to the site, setup, clean up and travel from the site. The cost of the additional insulation, to raise the R-value, is the labor and materials’ charge for the actual installation. As a result, for a ceiling using a blown insulation product, the cost of additional insulation is small; therefore, even though the savings are small, they may be economically justifiable.

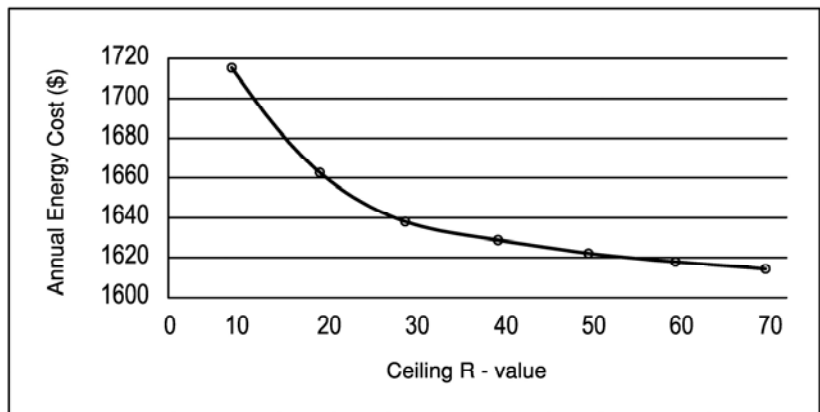

Figure 2 - 2 Annual Energy Cost for a Code Home with Different Ceiling R-values

Determining the cost of raising the R-value for other areas of the house is more complex to calculate. The Home Energy Rating System (HERS) software can calculate a reasonable estimate of the savings of energy efficiency improvements, like increasing the R-value of the wall. However, a builder must carefully consider all the costs associated with that change. For example, replacing the ½-inch oriented strand board (OSB) on an exterior wall with ½-inch rigid insulation is basically a change in materials cost plus the addition of corner reinforcement; however, replacing the ½-inch OSB with 1-inch rigid insulation results in additional costs for window and door trim, brick ledge considerations, etc.

ENERGY EFFICIENCY INCENTIVES AND FINANCING

Check with local representatives of your utilities' provider to determine whether incentives are provided for ENERGY STAR® homes. Utilities have provided support for builders and owner-builders of efficient homes that meet certain energy savings criteria.

Local lenders may participate in national energy efficient lending programs. These programs provide different finance options depending on the lender. The most common incentive offered is to allow homebuyers to stretch their debt-to-income ratio, meaning they can borrow a little more money than traditional lenders would usually allow, based on projected energy cost savings.

A positive economic return is an important benefit of home design that incorporates the features of the key components of energy efficient construction. The energy savings that exceed the additional annual mortgage costs of installing the features of the key components of energy efficient construction result in immediate savings for the home buyer. As energy costs increase, an energy saving feature that costs more to install than the additional annual mortgage costs may increase the value of the home more than the additional cost. Because these features can be installed at various levels, for example wall insulation, the term energy efficient improvement is used to describe a detailed analysis of the economics of installing a feature at a specific level.

CHAPTER 3: THE HOUSE AS A SYSTEM

It is common to think of houses as independent structures, placed on an attractive lot; however, the house and lot combine to form a complex system of related components. The actual house, the outside environment and the indoor environment must function as a unit. When properly designed, each part functions to provide a safe, comfortable and healthy living environment for the occupants. Amid fluctuating temperatures, moisture levels, and air pressures, the house's systems are designed and built to minimize problems. The interrelationship of these systems sometimes produces surprising and unforeseen consequences.

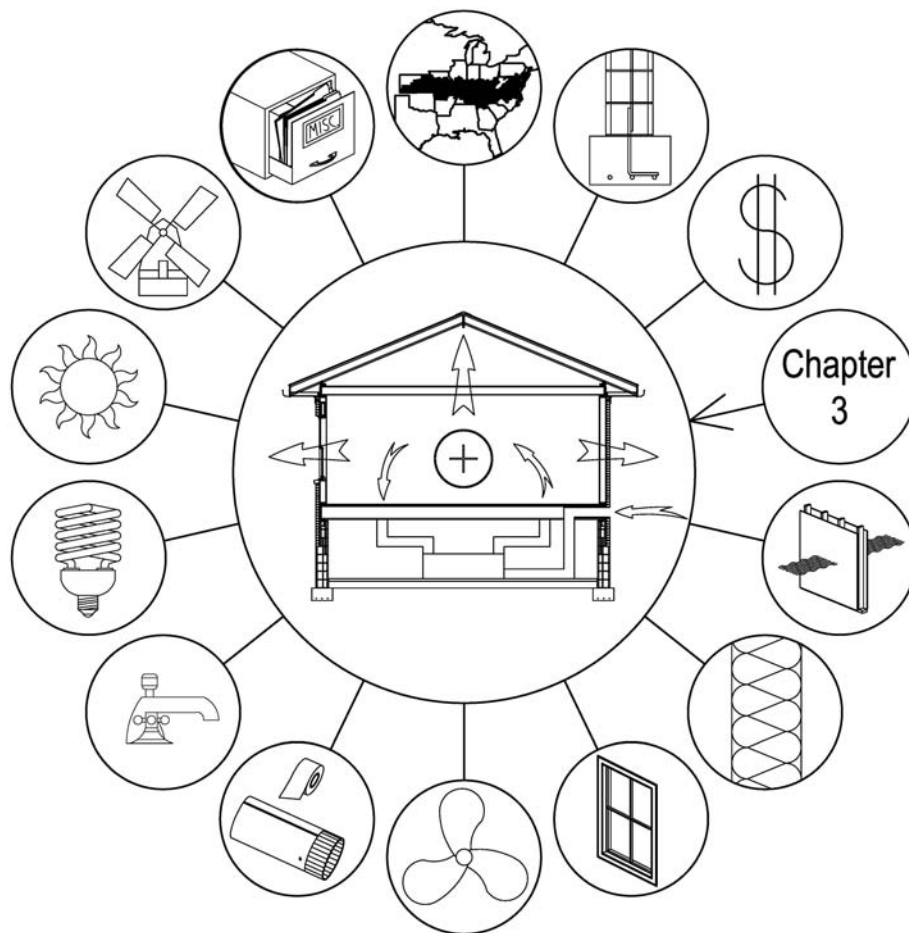



HOUSEHOLD ENVIRONMENT

A house's many assets can quickly be diminished by persistent environmental problems. Most homes will have problems in some part of the system. These environmental problems could range from being merely minor nuisances to being life threatening. Some frequent problems found in Kentucky homes are:

- Mold on walls, ceilings, and furnishings
- Mysterious odors
- Excessive heating and cooling bills
- High humidity
- Rooms that are never comfortable
- Decayed structural wood and other materials
- Termite or other pest infestations
- Fireplaces that do not draft properly
- High levels of formaldehyde, radon or carbon monoxide
- Water leaks
- Wet basements

When any of these problems occur, the house has not reacted properly to the outdoor or indoor environment. Viewing the house and the lot as a complex unit will increase the likelihood of the construction of a durable, healthy, energy efficient structure.

The following factors help define the quality of the living environment. If kept at desirable levels, the house will provide comfort and healthy air quality.

- Temperature—measured by a regular thermometer.
- Relative humidity levels—high humidity causes discomfort and can promote growth of mold and organisms, such as dust mites.
- Air quality—the level of pollutants in the air, such as formaldehyde, radon, carbon monoxide, and other detrimental chemicals, as well as organisms such as mold, pollen, and dust mites. The key cause of air quality problems is the strength of the source of pollution.
- Air movement—the velocity at which air flows in specific areas of the home. Higher velocities make occupants more comfortable in summer, but less comfortable in winter. Air moving through many common types of insulation can reduce insulating values.

Health, comfort, and energy bills are affected considerably by how readily heat moves through a home and its exterior envelope. New homes are required to meet energy codes, which require insulation on all exterior surfaces—floors, walls, and ceilings. While there is a wide variation in the percentages of where heat is lost and gained in the building envelope, Table 3-1 shows the percentage that each of the building components contributes to the heat loss and gain of a typical home that meets the energy code (Code Home used in previous illustrations). Energy efficient improvements can be made to reduce these levels. Duct losses to the outside can be eliminated by locating the ducts inside the building envelope; proper sealing of the building envelope can reduce infiltration and mechanical ventilation can be used to control indoor air quality.

Components	Code Home¹ HERS = 98
Ceiling	3%
Walls	22%
Doors	1%
Windows	25%
Floor	5%
Infiltration	25%
Ducts	19%

¹ A two-story, 2,000 sq ft home in Lexington, KY, exactly meeting the 2006 International Energy Conservation Code.

In summer, cooling needs are primarily determined by the location and shading of windows. In addition, the percentage of the cooling load that is for latent cooling (humidity removal) can increase substantially in homes with a well-insulated thermal envelope. The major sources of moisture, some of which can be controlled, include cooking activities, human respiration and perspiration, large amounts of indoor plants and infiltration of hot, humid, exterior air. Tighter homes have reduced humidity levels in summer.

THINGS TO KNOW - BASIC CONCEPTS

Before actually building an energy efficient home, it is important to understand four basic concepts that relate to all components of the design and construction. The movement of heat, air, and moisture, plus relative humidity influences the comfort and health of the home dwellers.

HOW HEAT MOVES IN HOMES

Conduction is the transfer of heat through solid objects, such as the ceilings, walls, and floors of a home. Insulation (and multiple layers of glass in windows) reduces conduction losses. The direction of heat flow is from hot to cold. Figure 3-1 shows conduction from a warm interior to a cooler outdoors.

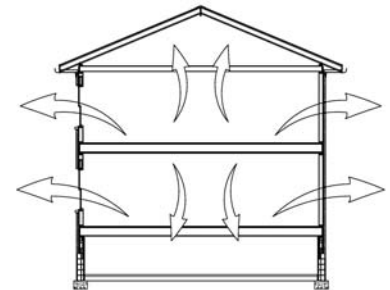

Figure 3 – 1 Conduction Heat Transfer



Convection is the flow of heat by currents of air. Air currents are caused by wind pressure differences, stirring fans, and air density changes as the air heats and cools (Figure 3-2). As air becomes heated, it becomes less dense and rises; as air cools, it becomes more dense and sinks.

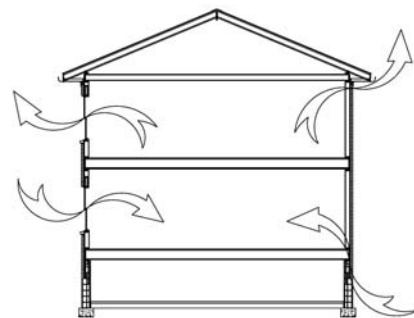

Figure 3 – 2 Convection Heat Transfer

Radiation is the movement of energy in electromagnetic waves from warm to cooler objects across empty spaces, such as radiant heat traveling from the roof deck to the attic insulation on a hot sunny day (Figure 3-3).

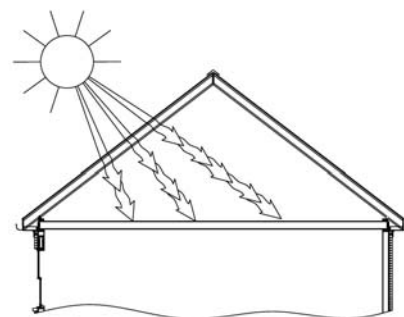

Figure 3 – 3 Radiation Heat Transfer

HOW AIR MOVES IN HOMES

Air movement is influenced by air leakage. Conditions for air leakage to occur are:

- Holes—the larger the hole, the greater the air leakage. Large holes have higher priority for air sealing efforts, and
- Driving force—a pressure difference that forces air to flow through a hole. Holes that experience stronger and more continuous driving forces have higher priority for sealing efforts.

The common driving forces are:

- Wind—caused by weather conditions.
- Stack effect—upward air pressure due to the buoyancy of air.
- Mechanical blower—induced pressure imbalances caused by operation of fans and blowers.



WIND

Wind is usually considered to be the primary driving force for air leakage in mild climates. When the wind blows against a building, it creates a high pressure zone on the windward areas. Outdoor air from the windward side infiltrates the building while air exits on the leeward side. Wind acts to create areas of differential pressure that cause both infiltration and exfiltration. Figure 3-4 illustrates both the higher pressure (+) on the windward side and the lower pressure (-) on the leeward side. The degree to which wind contributes to air leakage depends on its velocity and duration. Most homes have only small cracks on the exterior.

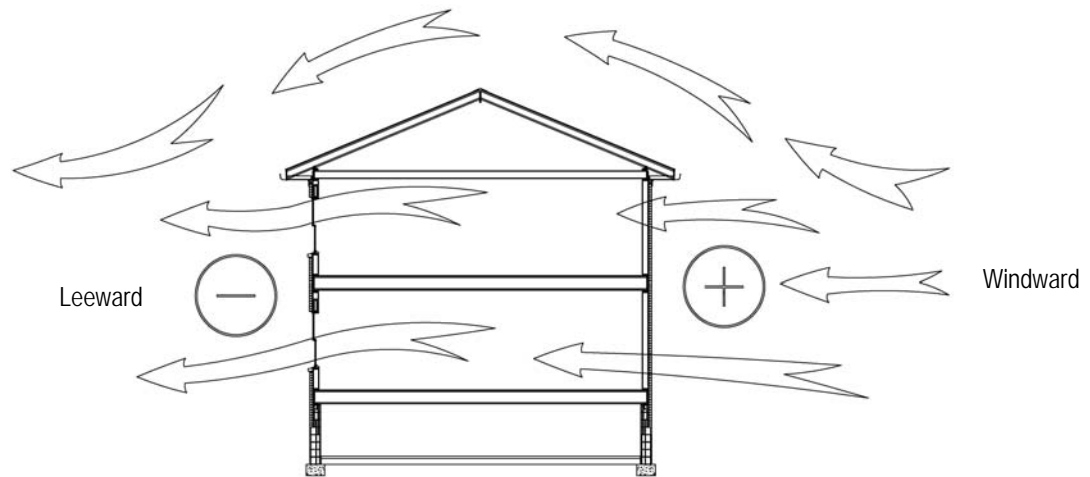

Figure 3 - 4 Wind Driven Infiltration

On average, winds typically found in the southeastern U.S. create a pressure difference of 10 to 20 Pascals on the windward and leeward sides of a house.

STACK EFFECT

The temperature difference between inside and outside causes warm air inside the home to rise while cooler air falls, creating a driving force known as the “stack effect” (Figure 3-5). The stack effect is what causes a chimney to operate. As heated air rises, it will escape through any opening in the upper area of the home and air will be drawn in at a lower level. The stack effect is weak but always present. Most homes have large access holes into the attic, crawl space or basement. Because the stack effect is so prevalent and the holes through which it drives air are often so large, it is usually a major contributor to air leakage, moisture, and air quality problems especially in winter.

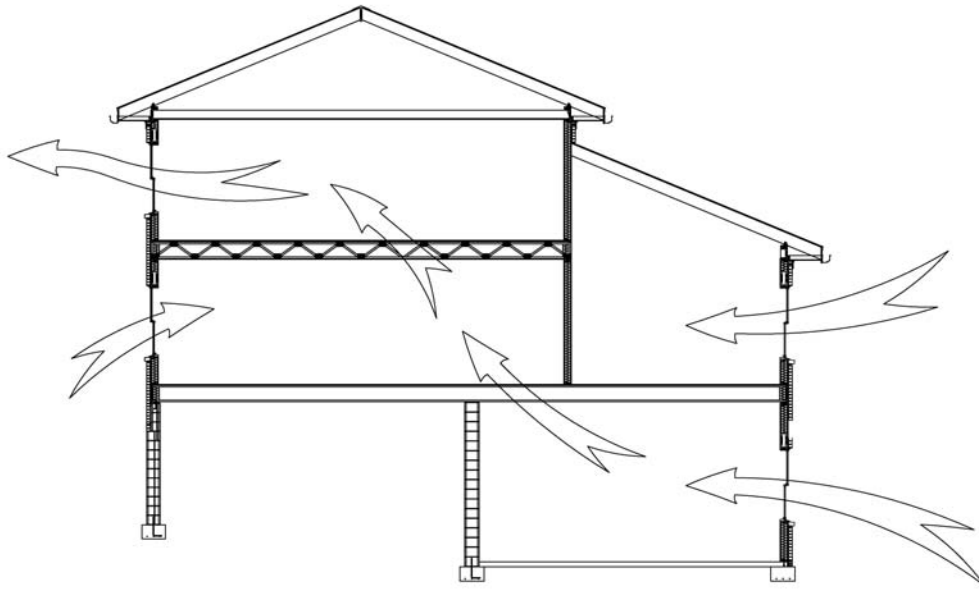

Figure 3 – 5 Stack Effect

The stack effect can create pressure differences between 1 to 3 Pascals due to just the power of rising warm air. Crawl space and attic openings are often large.

MECHANICAL

Poorly designed and improperly installed forced-air systems can create strong pressure imbalances inside the home (Figure 3-6), which can triple air leakage whenever the home heating and cooling system operates. In addition, unsealed ductwork located in attics and crawl spaces can draw pollutants and excess moisture into the home. Correcting duct leakage problems is critical when constructing an energy efficient home. For example, the HERS = 98 home in Table 3-1 could save \$61 per year by reducing its duct loss by 50% from 120 cfm to 60 cfm.

Air pressure is typically expressed in inches of water or Pascals. The pressure exerted by 0.004 inches of water equals one Pascal. The reason that Pascals is more frequently used than inches of water in air infiltration measurements, as a measurement of air pressure, is that the Pascal measurement simply uses larger numbers. The home building industry uses both measurement systems. Inches of water are commonly used for HVAC equipment and duct pressure measurements. Pascals are commonly used for the very low pressure measurements of air caused by wind, etc.

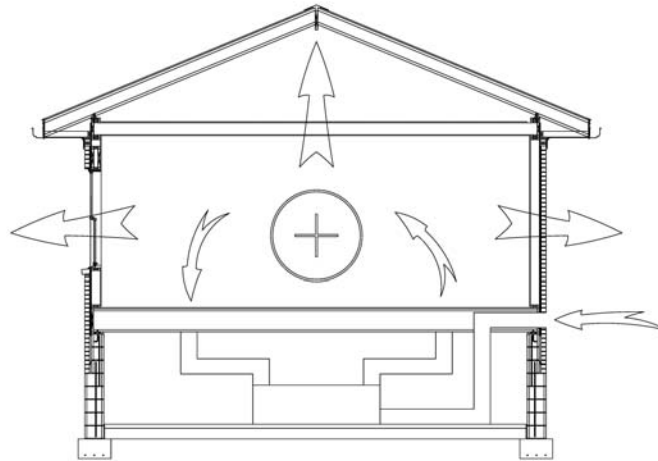

Figure 3 - 6 Mechanical System Driven Infiltration

Leaks in supply and return ductwork can cause pressure differences of up to 30 Pascals. Exhaust equipment, such as kitchen fans, bath fans, and clothes dryers can also create pressure differences.

HOW MOISTURE MOVES IN HOMES

There are four primary modes of moisture migration into our homes. Each must be controlled to preserve comfort, health, and durability. Most moisture problems are challenging to diagnose because one or all of the four primary modes of moisture movement may factor into the problem. This chapter concludes with three problems, two of which involve the interaction and interrelationship of moisture transport modes.

1) BULK MOISTURE TRANSPORT

- Bulk moisture transport is the flow of water through holes, cracks, and gaps.
- Its primary source is rain.
- Causes include:
 - poor flashing;
 - inadequate roof drainage;
 - poor quality weather-stripping, or caulking around joints in building exterior (such as windows, doors, and bottom plates); and
 - groundwater seepage due to adjacent ground not being sloped away from the house.
- Any problems are solved through quality construction with durable materials.
- This is the most important of the four modes of moisture migration (Figure 3-7).

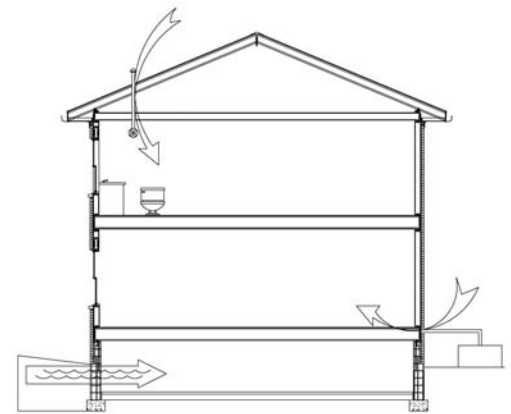

Figure 3 - 7 Bulk Moisture Transport



2) CAPILLARY ACTION

- Capillary action is the wicking of water through porous materials or between small cracks.
- Its primary sources are from rain or ground water.
- Causes include:
 - water seeping between overlapping pieces of exterior siding;
 - water drawn upward through pores or cracks in concrete slabs and walls made of concrete or concrete block;
 - water migrating from crawl spaces into floor and wall framing.
- Any problems are solved by completely sealing pores or gaps, increasing the size of the gaps (usually to a minimum of $\frac{1}{8}$ inch), or installing a waterproof, vapor barrier material to form a capillary break (see Figure 3-8).

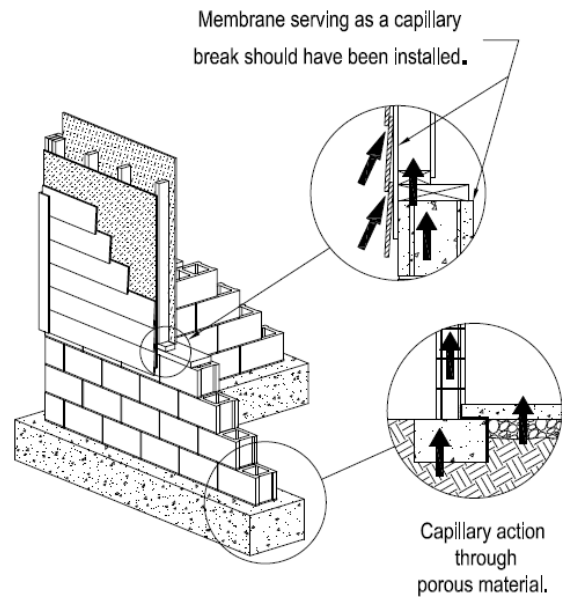

Figure 3 - 8 Capillary Action

3) AIR TRANSPORT

Air transport is the flow of air, containing water vapor, into enclosed areas through unsealed penetrations or joints between conditioned and unconditioned areas. As shown in Figure 3-9, air transport can bring 50 to 100 times more moisture into wall cavities than vapor diffusion.

- Its primary source of moisture is the water vapor in air.
- Causes include:
 - air leaking through holes and cracks;
 - other leaks between interior air and enclosed wall cavities;
 - interior air and attics;
 - exterior air adding humidity to interior air in summer; and
 - crawl spaces and interior air.
- Any problems are solved by creating an air barrier system.

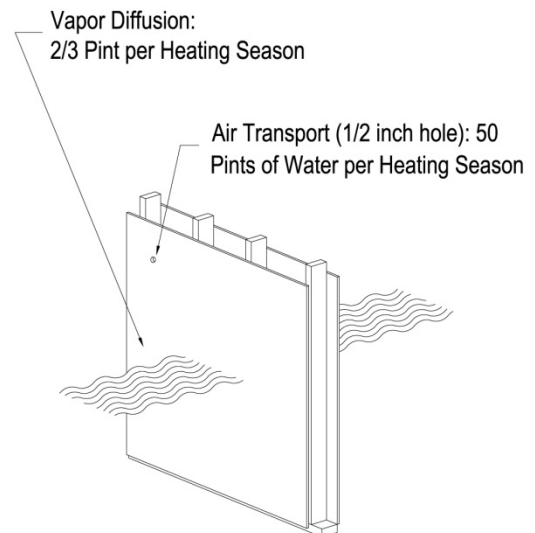

Figure 3 - 9 Air Transport of Water Vapor



4) VAPOR DIFFUSION

- Vapor diffusion is the movement of water vapor in air through permeable materials. A perm at 73.4°F (23°C) is a measure of the number of grains of water vapor passing through a square foot of material per hour at a differential vapor pressure equal to one inch of mercury. Any material with a perm rating of less than 1.0 is considered a vapor retarder.
- Its primary source is water vapor in the air.
- Causes include:
 - interior moisture permeating wall and ceiling finish materials;
 - exterior moisture moving into the home in summer; and
 - crawl space air moisture migrating through the floor into the home.
- Any problems are solved by proper installation of a vapor retarder. The common term is “vapor barrier;” however, few materials are actual vapor barriers. Vapor retarders are not required in Climate Zone 4 but are required in Climate Zones 5 and higher.
- This is the least important of the four modes of moisture migration, in Climate Zone 4.

RELATIVE HUMIDITY

Air is made up of gases (oxygen, nitrogen, etc.) and water vapor. The amount of water vapor that air can hold is determined by its temperature. Warm air can hold more water vapor than cold air. The amount of water vapor in the air is measured by its relative humidity. At 100% relative humidity (RH), water vapor condenses into a liquid. The temperature at which the water vapor in the air condenses is its dew point. Therefore, the dew point of air depends on its temperature and relative humidity. Preventing condensation involves either reducing the relative humidity of the air or increasing the temperatures of surfaces exposed to the air.

Determining the relative humidity is important when trying to check the performance of heating and cooling equipment or determining the cause of problems. The least expensive device for measuring relative humidity is the sling psychrometer. This device has two glass thermometers, one with a cotton wick on the thermometer bulb. To determine humidity, this wick is wet with clean water. Then, in order to move air across the two bulbs, the psychrometer is either twirled, for about a minute, by the handle or put in a fan draft. One thermometer will read the dry bulb temperature, and the other will read the wet bulb temperature. Charts permit the dry and wet bulb temperatures to be used to reliably and accurately determine relative humidity.

Digital relative humidity sensors are also available and can be simpler to use in locations such as a supply air duct. The readings are typically displayed as a digital readout, so additional charts are not required. They are often combined with a temperature sensor so that both measurements can be taken at the same time. Digital sensors can be contained in small data loggers, which allow measurements to be taken as often as every minute over several days. This can be important when assessing problems that occur infrequently.

A convenient tool for examining how temperature, moisture, and air interact is a psychrometric chart. A psychrometric chart aids in understanding the dynamics of moisture control. A simplified chart, shown in Figure 3-10, relates temperature and moisture. Temperature increases from left to right and the amount of moisture in the air increases from the bottom up. The upper left curve of the chart is the 100% relative humidity line. Air can hold no additional water vapor at that temperature, which is the dew point. If the air temperature goes below the dew point temperature, condensation will occur.

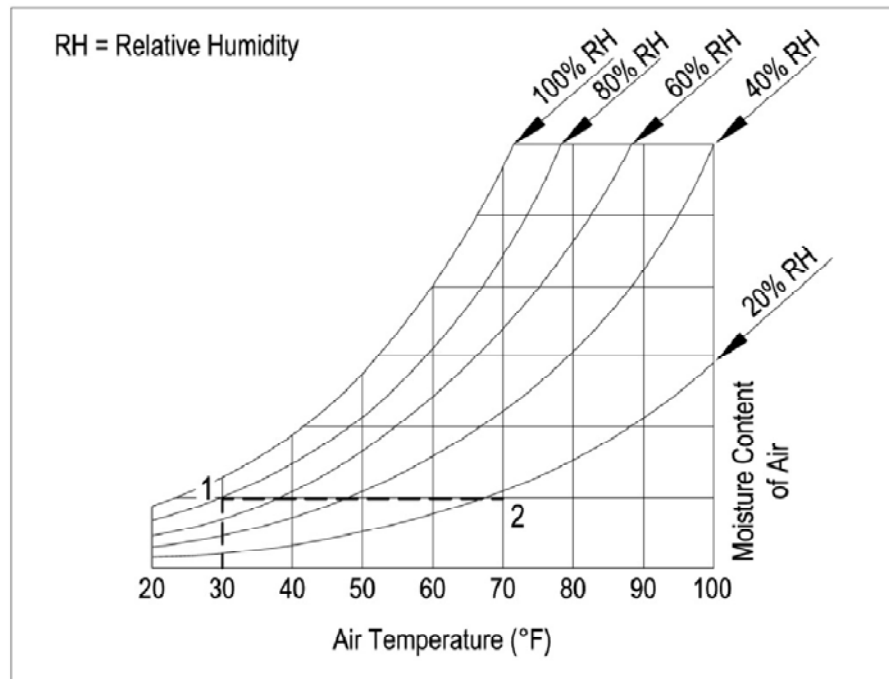

Figure 3 – 10 Psychrometric Chart

WHY INDOOR AIR IS DRY IN WINTER

Air leaking into a residence, in winter, will reduce the humidity levels in a home. For example, if outside air, at 30°F and 80% relative humidity leaks into a home, the air will warm up to the indoor temperature of 70°F. However, the relative humidity of this warmed air would only be about 18%.

A psychrometric chart can show why this happens. Match the step number (1 and 2) with the same number on the graph in Figure 3-10.

1. Find the point (1) representing the outdoor air conditions (30°F at 80% RH).
2. Draw a horizontal line to 70°F and read the relative humidity, 18%.

WINTER CONDENSATION IN WALLS

In a well-built wall, the temperature of the inside surface of the sheathing will depend on the insulating value of the rest of the wall and the sheathing, and the indoor and outdoor temperatures. Consider the following example: if it is 35°F outside and 70°F at 40% relative humidity inside, then:

- The interior surface of plywood sheathing would be around 39°F and
- The interior surface of insulated sheathing would be 47°F.



The psychrometric chart can help predict whether condensation will occur in this example. Match the step number (1, 2, or 3) with the same number on the graph in Figure 3-11.

1. Find the point (1) representing the indoor air conditions (70°F at 40% RH).
2. Draw a horizontal line to the 100% RH line.
3. Draw a vertical line down from where the horizontal line intersects the 100% RH line to read the dew point temperature, 44°F. In the example, condensation would occur if the temperature of the inside surface of the sheathing were at 44°F. Thus, under the temperature conditions in this example, water droplets may form on the plywood sheathing (which would be around 39°F), but not on the insulated sheathing (which would be around 47°F).

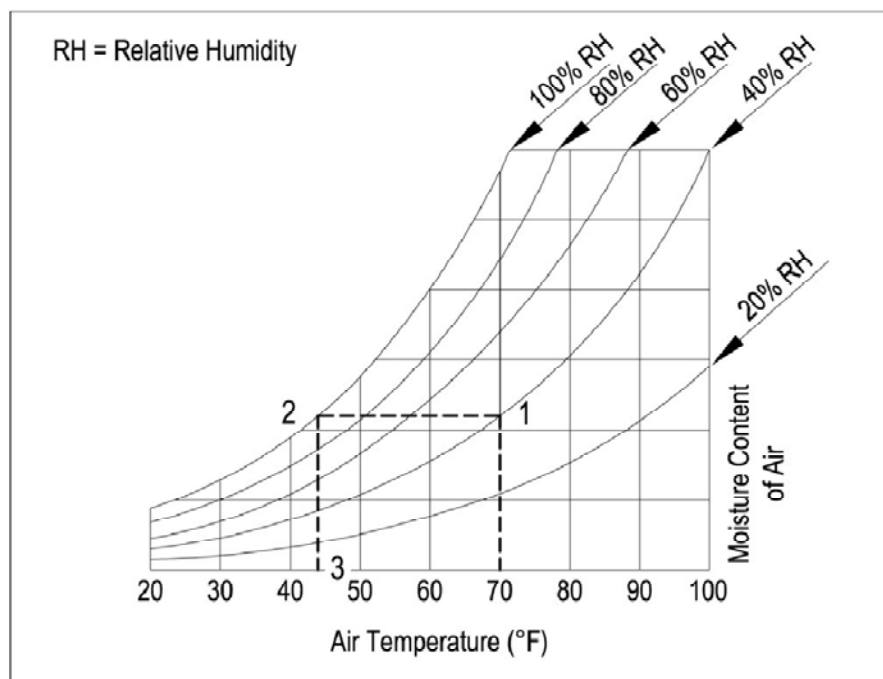

Figure 3 – 11 Psychrometric Chart – Winter Dew Point

SUMMER CONDENSATION IN WALLS

Figure 3-12 depicts another moisture and relative humidity problem, only this time summer conditions exist. If the interior air is 75°F, and outside air at 95°F and 40% relative humidity enters the wall cavity, will condensation occur?

The psychrometric chart can help predict whether condensation will occur in this example. Match the step number (1, 2, or 3) with the same number on the graph in Figure 3-12.



1. Find the point (1) representing the outdoor air conditions (95°F at 40% RH).
2. Draw a horizontal line to the 100% RH line.
3. Draw a vertical line down from where the horizontal line intersects the 100% RH line to read the dew point temperature, 67°F. In this example, because the drywall temperature (75°F) is greater than the dew point, condensation should not form.

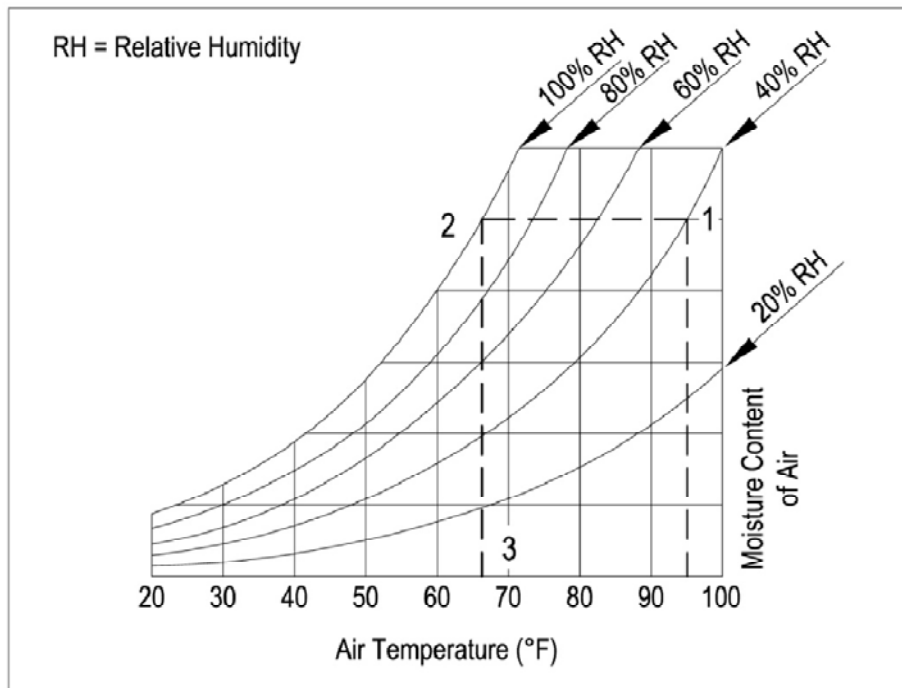

Figure 3 – 12 Psychrometric Chart – Summer Dew Point Temperature on Inside Wall

EFFECT OF RELATIVE HUMIDITY

There are a variety of ways in which humans respond to changes in relative humidity:

- Ideal health and comfort for humans occurs at 30% to 50% RH;
- At lower relative humidity levels, we feel cooler as moisture evaporates more readily from our skin;
- At higher relative humidity levels, we may feel uncomfortable, especially at temperatures above 78°F;
- Dry air, less than 30% RH, can often aggravate respiratory and skin problems;
- Molds grow in air over 70% RH;
- Dust mites prosper at or above 50% RH, and
- Wood decays when the RH is near or at 100%.



SYSTEMS IN A HOUSE

Whether the health and comfort factors of temperature, humidity, and air quality remain at comfortable and healthy levels depends on how well the home works as a system. Every home has the following systems that are intended to provide indoor health and comfort:

- Structural system
- Thermal insulation system
- Air leakage control system
- Moisture control system
- Comfort control system provided by the HVAC system

STRUCTURAL SYSTEM

The purpose of this book is not to show how to design and build the structural components of a home, but rather to describe how to maintain the home's integrity, while using energy efficient components. Key problems that can affect the structural integrity of a home include:

- Frost heaving
- Erosion
- Rain water intrusion such as roof leaks
- Water absorption into building materials
- Excessive relative humidity levels
- Fire
- Summer heat build-up

To create and maintain the structural integrity of the home, the home designer and builder should:

- Ensure that the footer is installed level and below the frost line. Install adequate reinforcing and make sure that the concrete has the proper slump and strength.
- Divert ground water away from the building through a properly designed and installed foundation drainage system. Install effective gutters, downspouts, and rainwater drains.
- Ensure that the roof is watertight to prevent rainwater intrusion. Seal penetrations that allow moisture to enter the building envelope via air leakage.
- Ensure that there is a drainage plane on the exterior wall to prevent wind driven rainwater from entering.
- Ensure that all flashing is installed properly.
- Use fire-stopping sealants to close penetrations that are potential sources of "draft" during a fire.
- Install a series of capillary breaks that keep moisture from migrating through foundation into floor, wall and attic framing.

THERMAL INSULATION SYSTEM

Thermal insulation and energy efficient windows are intended to reduce heat loss and gain due to conduction. As with other aspects of energy efficient construction, the key to a successfully insulated home is quality installation. Improperly installed insulation not only inflates energy bills, but also may create comfort and moisture problems. Chapter 5 discusses insulation in detail; however, the main considerations for effective insulation include:



- Install R-values equal to or exceeding the energy code against the air barrier material. For example, install R-19 floor insulation flush against the subfloor, not dropped down at the base of the floor joists or trusses.
- Do not compress insulation to less than its rated thickness.
- Provide full insulation coverage of the specified R-value; gaps dramatically lower the overall R-value and can create areas subject to condensation.
- Prevent air leakage through the insulation—with some insulating materials, R-values actually decline when cold air leaks through.
- Air seal and insulate knee walls and other attic wall areas with a minimum of R-13 insulation.
- Support insulation so that it remains in place, especially in areas where breezes can enter or rodents may reside.

AIR LEAKAGE CONTROL SYSTEM

Air leakage (infiltration) can be detrimental to the long-term durability of homes. It can also cause a substantial number of other problems, including:

- High humidity levels in summer and dry air in winter
- Allergy problems
- Radon entry via leaks in the floor system
- Mold growth
- Drafts
- Window fogging or frosting
- Excessive heating and cooling bills
- Increased damage in case of fire

An air leakage control system may sound formidable, but it is actually a simple concept—seal all leaks between conditioned and unconditioned spaces with durable materials. Achieving success can be difficult without diligent efforts, particularly in homes with multiple stories and changing roof lines.

Air leakage control may also help a home meet local fire codes. One aspect of controlling fires is preventing oxygen from entering a burning area. Most fire codes have requirements to seal air leakage sites.

Chapter 4 describes a number of air leakage control systems—all can be effective with proper installation. As seen in Figures 3-13 and 3-14, the key features of air leakage control systems are:

- Seal all air leakage sites between conditioned and unconditioned spaces:
 - caulk or otherwise seal penetrations for plumbing, electrical wiring, and other utilities; use caulks and sealants which will remain pliable and will stick to the surface to which they are applied;
 - seal junctions between building components, such as bottom plates and band joists between conditioned floors; and
 - utilize air sealing insulating materials, like cellulose or plastic foam.
- Seal bypasses—hidden chases, plenums, and other air spaces through which attic or crawl space air leaks into the home.
- Install a continuous air barrier approach, such as the airtight drywall approach or continuous housewrap. This will yield an even tighter construction.

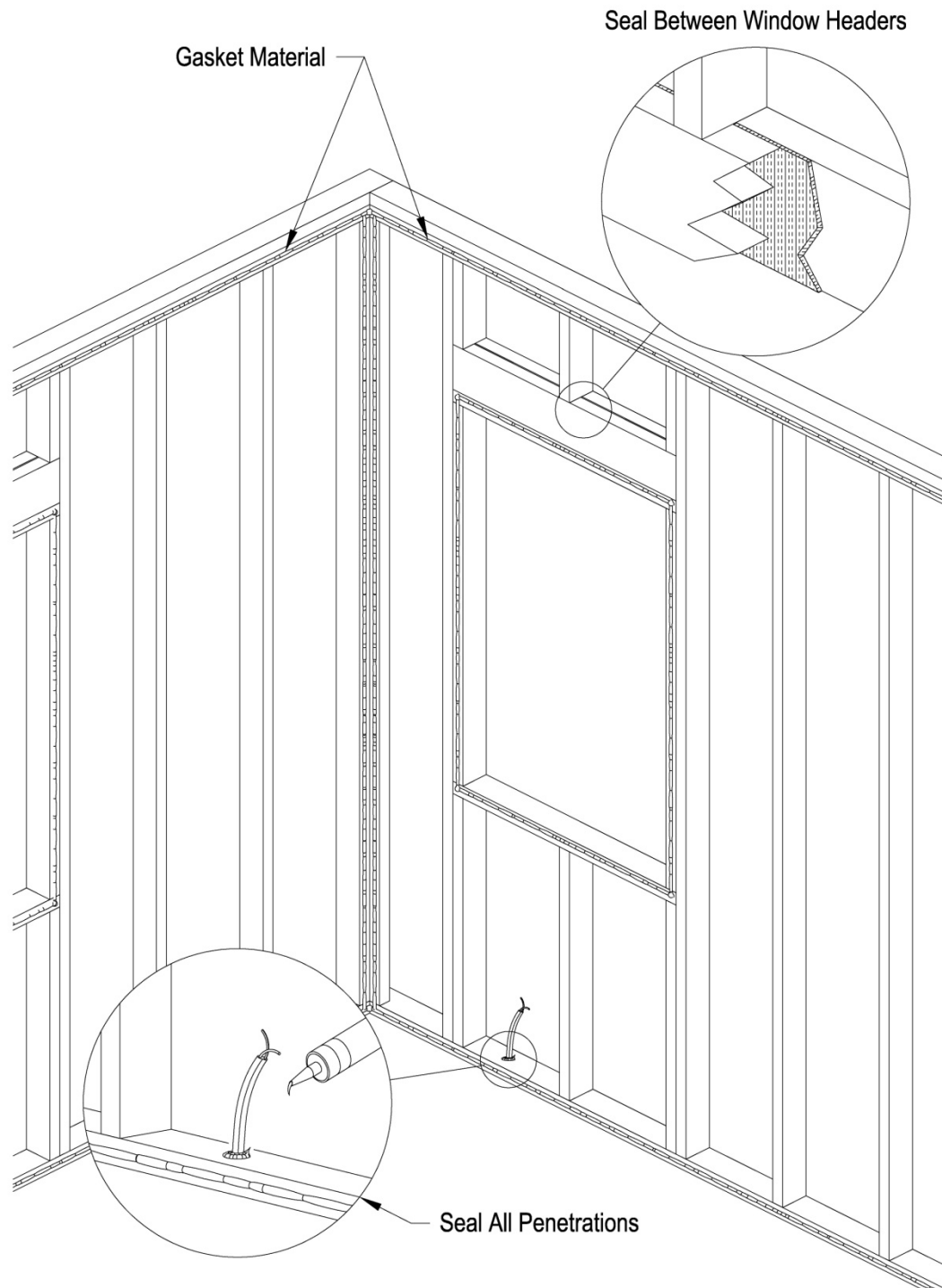

Figure 3 – 13 Install Continuous Air Barrier System

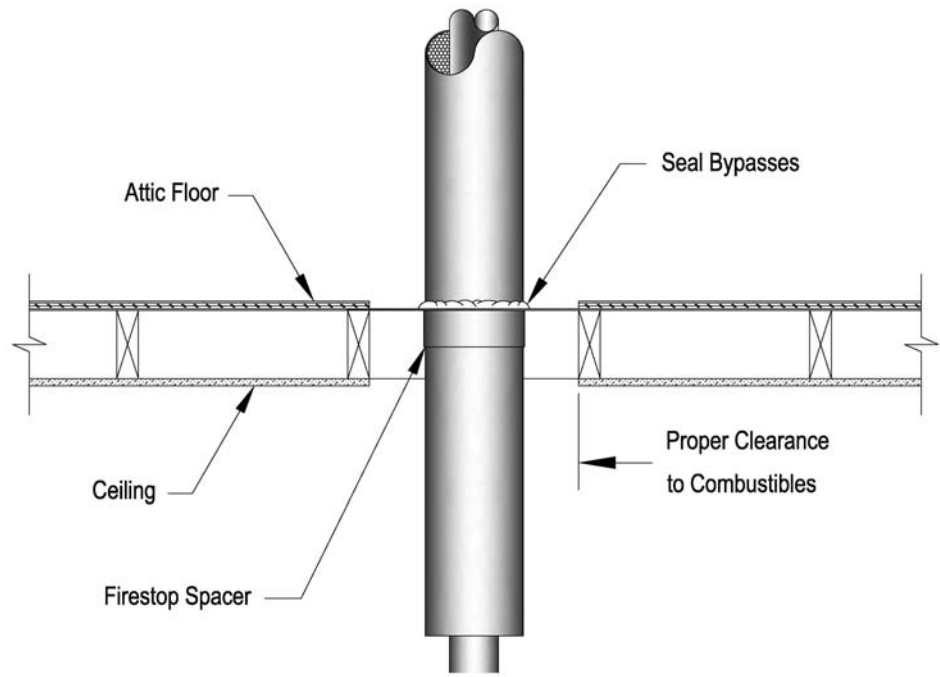
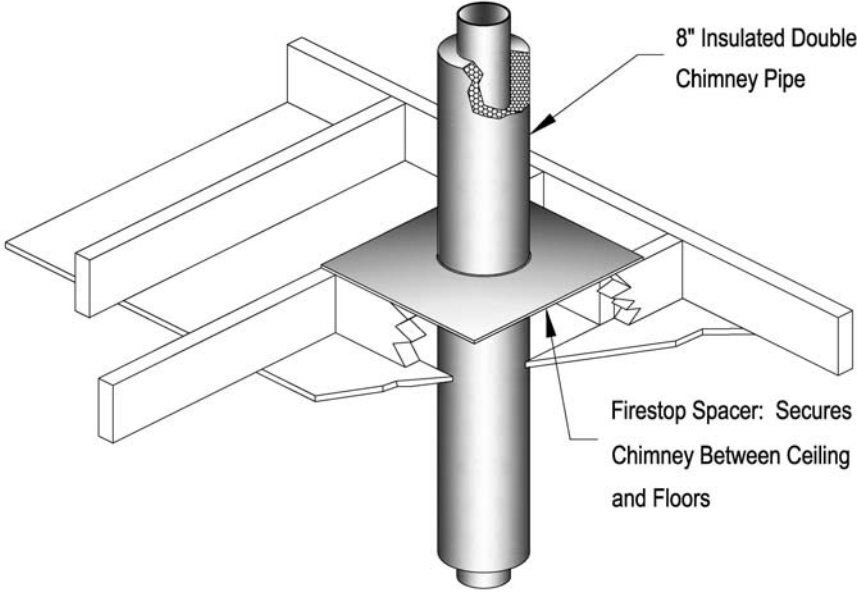

Figure 3 - 14 Air Barrier System Requirements



MOISTURE CONTROL SYSTEM

Homes should provide comfortable and healthy relative humidity levels. Remember that the ideal health and comfort level for human occupants is at 30% to 50% RH. Homes should also prevent liquid water and water vapor from migrating through building components.

A moisture control system includes quality construction that sheds water from the home and its foundation. The moisture control system also includes vapor and air barrier (infiltration) systems that hinder the flow of water vapor, and heating and cooling systems designed to provide comfort throughout the year.

COMFORT CONTROL SYSTEM PROVIDED BY THE HVAC SYSTEM

The heating, ventilation, and air conditioning system (HVAC) is designed to provide comfort and improved air quality throughout the year, especially in winter and summer. Energy efficient homes, particularly passive solar designs, can reduce the number of hours during the year when the HVAC systems are needed.

Heating and cooling systems are often neither well designed nor installed to perform as intended. Consequently, homes often suffer higher heating and cooling bills and have more areas with discomfort than necessary. Poor HVAC design often leads to moisture and air quality problems, too.

One major issue concerning HVAC systems is their ability to create pressure imbalances in the home. Duct leaks can create serious problems. Notice the areas in the illustrations (Figures 3-15, 3-16, 3-17 and 3-18) with positive (+) or negative (-) pressure. Even closing a few doors can create situations that may endanger human health.

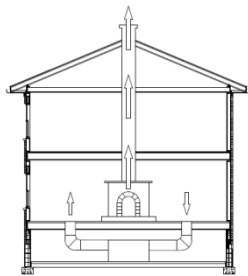

Figure 3 - 15 Balanced Air Distribution

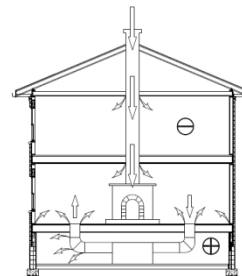

Figure 3 - 16 Air Leaks in Supply Ducts

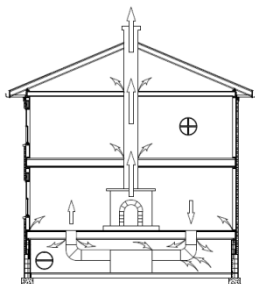

Figure 3 - 17 Air Leaks in Return Ducts

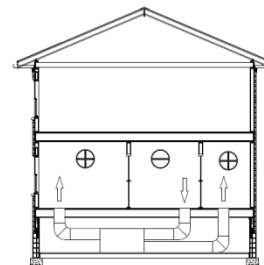

Figure 3 - 18 Return Blocked by Door



Pressure imbalances can increase air leakage, which may draw additional moisture into the home. Proper duct design and installation help prevent pressure imbalances. One of the most important components, considering the comfort control system of a high performance home, is an airtight duct system.

HVAC systems must be designed and installed properly, and maintained regularly by qualified professionals to provide efficient and healthy operation. Chapter 7 shows how to integrate ventilation systems with heating and cooling systems to provide fresh air when needed or desired.

DUCT LEAKS AND INFILTRATION

Forced-air heating and cooling systems should be balanced—the amount of air delivered through the supply ducts should be equal to that drawn through the return ducts. If the two volumes of air are unequal, pressure imbalances may occur in the home, resulting in increased air leakage, and possible health and safety problems.

If supply ducts, in unconditioned areas, have more leaks than return ducts:

- Heated and cooled air will escape to the outside, increasing energy costs;
- Less air volume will be “supplied” to the house; the pressure inside the house may become negative, thus increasing air infiltration; and
- The negative pressure can actually backdraft flues—pull exhaust gases back into the home from fireplaces and other combustion appliances. The health effects can be deadly if flues contain substantial carbon monoxide.

If return ducts, in unconditioned spaces, leak:

- The home can become pressurized, thus increasing air leakage out of the envelope;
- Hot, humid air is pulled into the ducts in summer; cold air is drawn into the ducts in winter;
- Radon and mold may enter the duct and endanger human health. Toxic chemicals, in the soil from termite treatments, paints, cleansers, and pesticides may also endanger human health; and
- Combustion appliances, if located near return leaks, may create a negative pressure, great enough to backdraft flues and chimneys.

Pressure differences can also occur in homes with tight ductwork, if the home only has one or two returns. When interior doors are closed, it may be difficult for the air in these rooms to circulate back to the return ducts. The pressure in a closed-off room increases, and the pressure in rooms open to the returns, decreases. The practice of undercutting doors in rooms with more than one register does not provide sufficient area to prevent pressure buildup.

To alleviate pressure problems resulting from closing doors to rooms with supply ducts, HVAC contractors can:

- In rooms with single supply registers:
 - Make sure doors have an adequate gap under them to allow air to pass, after installation of finish flooring. A 1½ inch gap is required for each 100 cfm of supply air.
 - Install separate returns; or
 - Install jumper ducts or transfer grilles that connect the room air to the air in the central portion of the home where the main return is located.



- In rooms with multiple supply registers:
 - Undercutting the door often does not provide sufficient air flow.
 - Use either a separate return jumper duct, or a transfer grille.

THREE PROBLEMS INVOLVING VARIOUS SYSTEMS

Problems tend to involve more than one home system and can be minimized through careful attention to the energy efficient improvements described in this book. The following three problems examine common concerns and ways of thinking to find a solution. These problems are due to common failures of the home's systems. The interaction between the systems must be considered to solve the problems.

MOISTURE PROBLEM EXAMPLE

The owner of a residence in Kentucky complains that her ceilings are dotted with mildew. Upon closer examination, an energy inspector finds that the spots are primarily around recessed lamps located close to the exterior walls.

What type of moisture problem may be causing the mildew growth? Environmental conditions for active mildew growth require at least 70% relative humidity. Any of the four primary modes of moisture transport could be responsible for the problem; however, in this case, bulk moisture transport and air transport are the primary sources.

Bulk moisture transport—the home may have roof leaks above the recessed lamps (Figure 3-19).

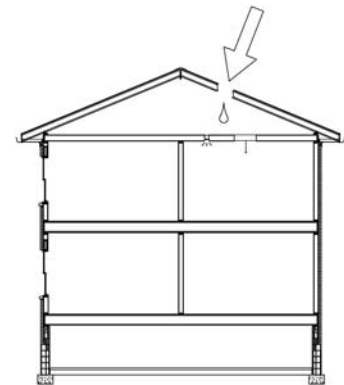
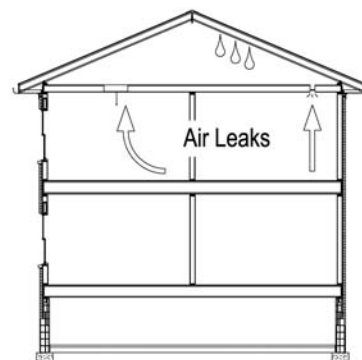

Figure 3 – 19 Bulk Moisture Transport – Roof Leak

Air transport—most recessed lamps are quite leaky. If the air leaking into the attic is relatively warm and moist, and if the recessed lamp is not insulation-contact rated (and is not covered by insulation) and the roof deck is cool, then the water vapor in the air may condense and drip onto the drywall (Figure 3-20).



Moisture Laden Air Forms
Condensation on Roof Deck

Figure 3 – 20 Air Transport



Capillary action and vapor diffusion—the home may have a severe moisture problem in its crawl space or under the slab. Via capillary action (see Figure 3-21), moisture travels up the slab, into the framing lumber, and into the home's air, raising the humidity. If the air becomes sufficiently moist, it may condense on the surface of the cool recessed light and drip onto the insulation and drywall around it, as seen in Figure 3-22. These are the least likely explanations.

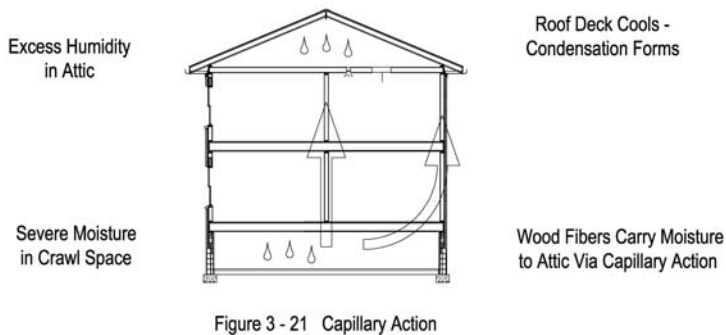

Figure 3 - 21 Capillary Action

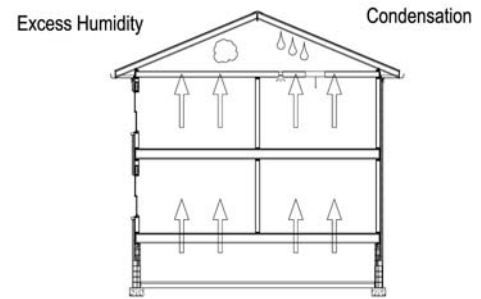

Figure 3 - 22 Vapor Diffusion

WALL MOISTURE EXAMPLE

In this example, a homeowner notices that paint is peeling on the exterior siding near the base of a bathroom wall, Figure 3-23. In addition, surface mold has formed on the interior drywall, and the baseboard paint is peeling. What is happening?

1. The interior of the wall has numerous air leaks around the electrical and plumbing fixtures.
2. The door to the bathroom is usually closed. When the HVAC system operates, the room becomes pressurized because it has no return and its door is not undercut. This is an HVAC system failure.
3. The bath fan is installed improperly and does not exhaust moist air to the out-of-doors—another HVAC system failure.
4. When air leaks into the wall, it carries substantial water vapor; thus, the failure of the air barrier and HVAC systems has led to a moisture control system failure.
5. The interior wall has vinyl wallpaper, which acts as a vapor barrier. The exterior wall has CDX plywood sheathing, which is a vapor barrier. This is a moisture control system failure.
6. When the air leaks carry water vapor into the wall cavity, the two vapor barriers hinder drying—a moisture control system failure.
7. In winter, the inner surface of the plywood sheathing will be several degrees cooler than the foam sheathing would have been. Thus, the plywood-sheathed wall has more potential for condensation—a thermal insulation system failure.



8. As the water vapor condenses on the sheathing, it runs down the wall and pools on the bottom plate of the wall. Now the following problems occur:
- The pooled water threatens to cause structural problems by rotting the wall framing.
 - The pooled water wets the drywall, causing mold to grow.
 - The pooled water travels through the unsealed back surfaces of the wood siding and baseboard, causing the paint to peel when it soaks through the wood.
 - The multiple failures of the building systems create a potential structural disaster.

To solve this moisture problem, the builder must address all of the failures. If only one aspect is treated, the problem may even become worse.

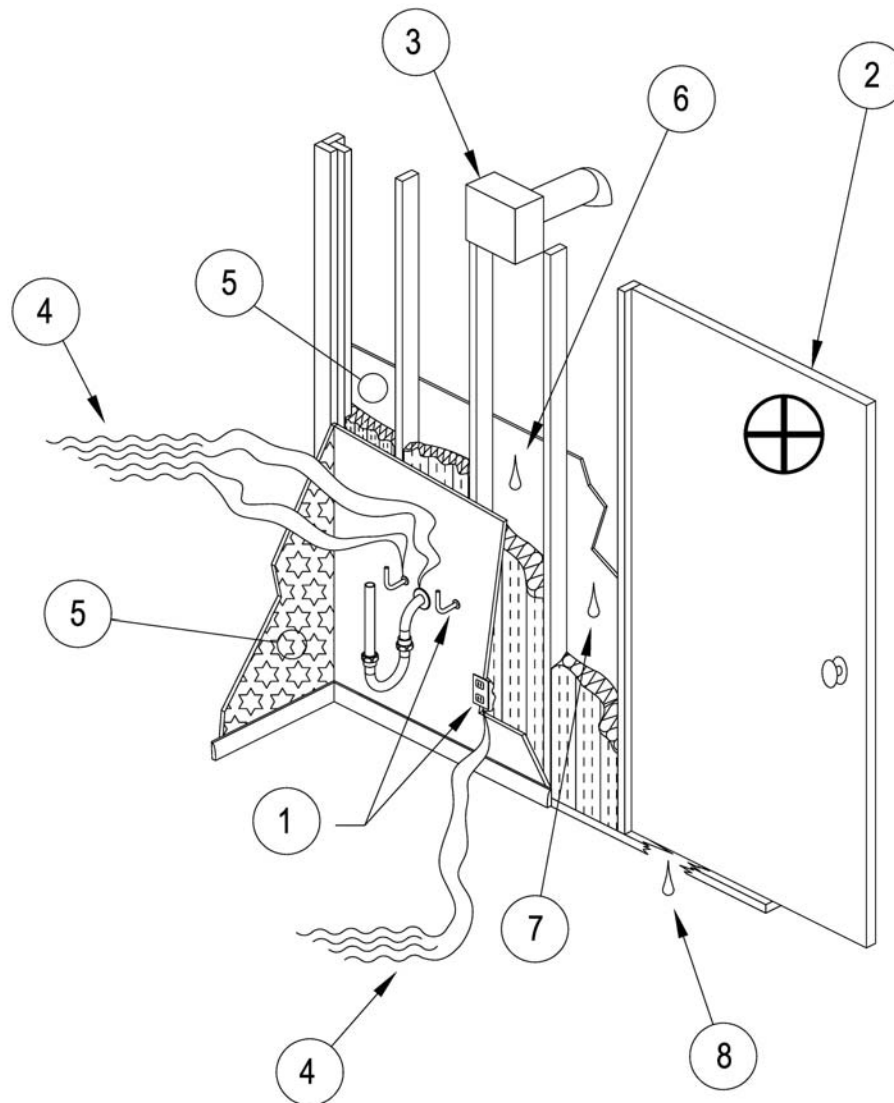

Figure 3 - 23 Wall Moisture Problems

CARBON MONOXIDE DISASTER

The third example involves the build-up of carbon monoxide in a home during the winter. Figure 3-24 illustrates the sequence that could contribute to the disaster.

1. A home has been built to airtight specifications—an air leakage control system success.
2. However, the home's ductwork was not well sealed—an HVAC system failure. The ductwork has considerably more supply leakage than return leakage, which creates a strong negative pressure inside the home, when the heating and cooling system operates.
3. The homeowners are celebrating winter holidays. With overnight guests in the home, many of the interior doors are kept closed. The home has only a single return in the main living room.
4. When the heating system operates, the rooms with closed doors become pressurized. Meanwhile, the central living area, with the single return, becomes significantly depressurized. Because this house is very airtight, it is easier for these pressure imbalances to occur.
5. The home has a beautiful fireplace, without an outside source of combustion air. When the fire in the grate begins to dwindle, the following sequence could spell disaster for the household.

- The fire begins to smolder and produces considerable carbon monoxide (CO).
- As the fire's heat dissipates, the draft pressure, which draws gases up the flue, decreases.
- The reduced output of the fire causes the thermostat to turn on the heating system. Due to the duct problems, the blower creates a relatively high negative pressure in the living room.
- Because of the reduced draft pressure in the fireplace, the negative pressure in the living room causes the chimney to backdraft. The flue gases contain carbon monoxide and can now cause severe, if not fatal, health consequences for the occupants.

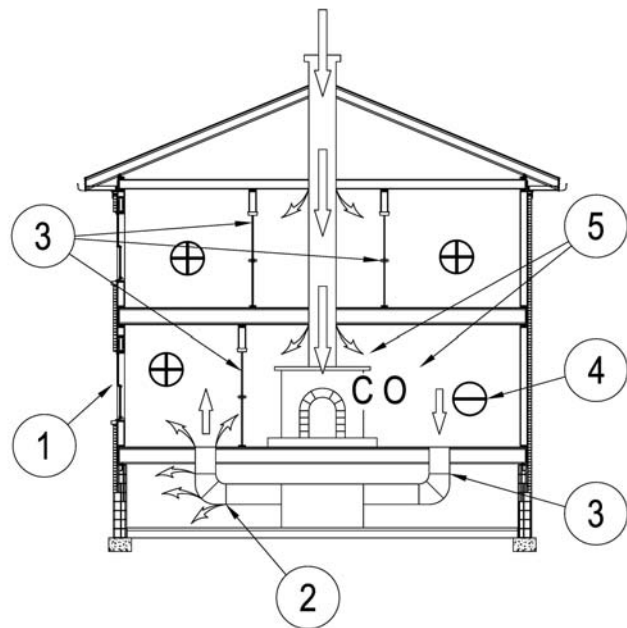

Figure 3 - 24 Carbon Monoxide Build-up

This example is extreme, but similar conditions occur in a number of Kentucky homes each year. The solution to the problem is not to build leakier homes—they can experience similar pressure imbalances. Instead, eliminate the causes of pressure imbalances, as described in detail in Chapter 7. Install a fireplace insert in the fireplace with sealed glass doors and have an external source of combustion air.

CHAPTER 4: AIR LEAKAGE CONTROL: MATERIALS AND TECHNIQUES

Air leakage (infiltration) is a major problem for both new and existing homes and can:

- Contribute over 30% of heating and cooling costs;
- Create comfort and moisture problems;
- Pull pollutants, such as radon and mold, into homes; and
- Reveal openings that serve as a prime entry for insects and rodents.

Reducing air leakage effectively requires a continuous air barrier system—a combination of materials linked together to create a tight building envelope. An air barrier also minimizes air currents inside the cavities of the building envelope, which helps maintain insulation R-values.

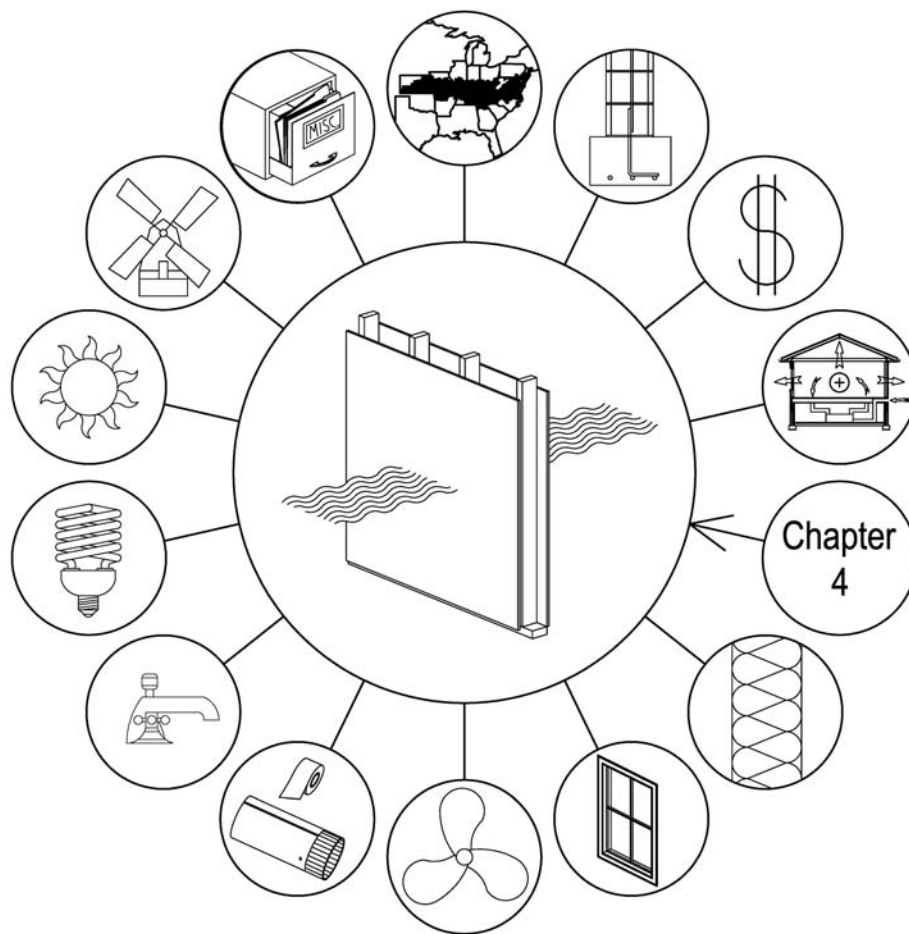



OVERVIEW

The air barrier should seal all leaks through the building envelope—the boundary between the conditioned portion of the home and the unconditioned area. Most standard insulation products are not effective at sealing air leakage. In fact, R-values for many products may drop if air leaks through the insulation.

Some spray-applied insulation materials, such as high-density cellulose, icynene foam, and urethane foam, can seal against air leakage. However, even when using these materials, air leaks remain and must still be sealed to form an effective air barrier system.

Builders should work with their own crews and subcontractors to seal all holes through the envelope. Then, the builders should install a continuous material, such as drywall, around the envelope. It is critical in the air sealing process to use durable materials and install them properly.

Vertical openings should be sealed with the proper materials to meet fire and smoke codes. Sealing these openings, including any penetrations through top and bottom sill plates, in both interior and exterior walls, greatly reduces air leakage.

Most air barrier systems rely on a variety of caulks, gaskets, weatherstripping, and sheet materials, such as plywood, drywall, polyethylene plastic, and housewraps. The extra cost of these materials is usually under \$300 for standard house designs. Solid materials that will last 50 to 100 years are preferable to caulks and adhesives.

SEAL FRAMING

When two framing members meet, they create a joint that can allow air leakage. It is best to use a gasket material to seal the joint, if possible; however, many of these joints require the use of caulk, Figure 4-1. Failure to seal the framing joints will limit the ability of the other seals to work effectively.

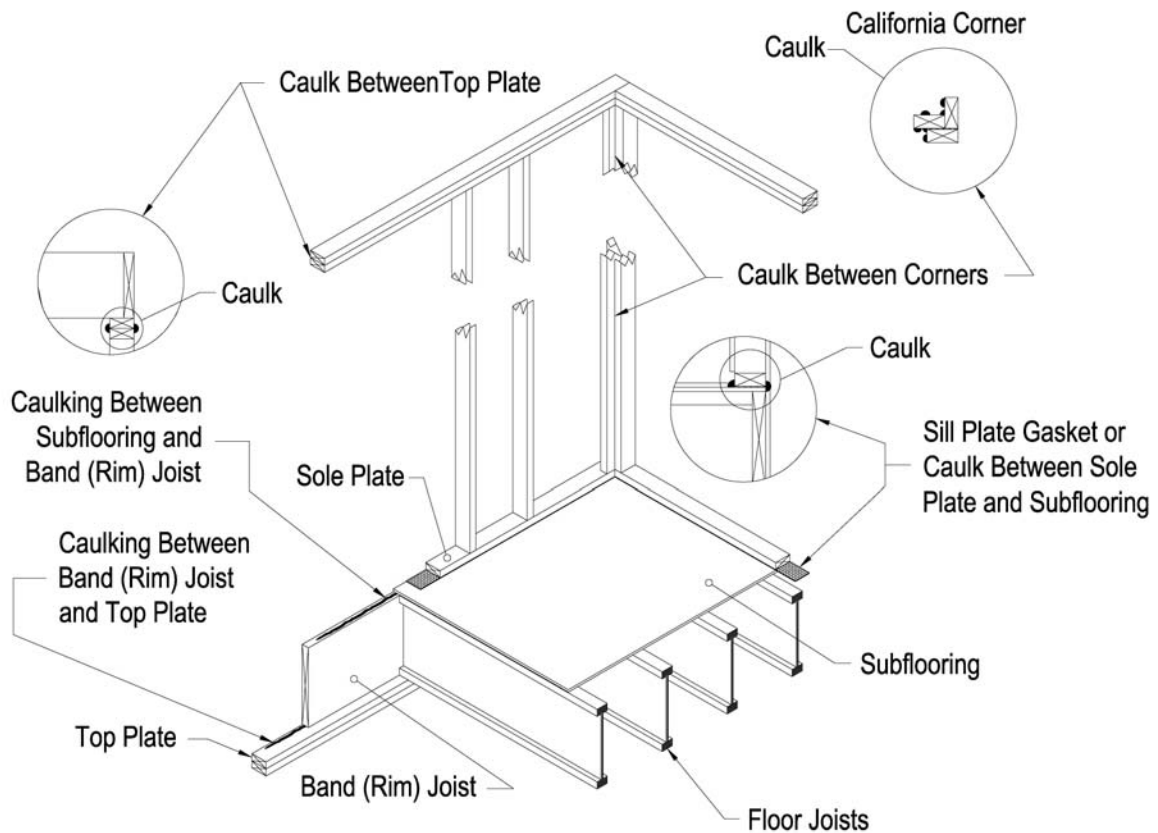

Figure 4 - 1 Seal the Framing

SEAL EXTERIOR

The exterior covering of the framing provides another opportunity to provide air leakage control. In the case where no housewrap is used, Figure 4-2, the exterior covering edges should be caulked to the framing and the joints between the sheets should be sealed.

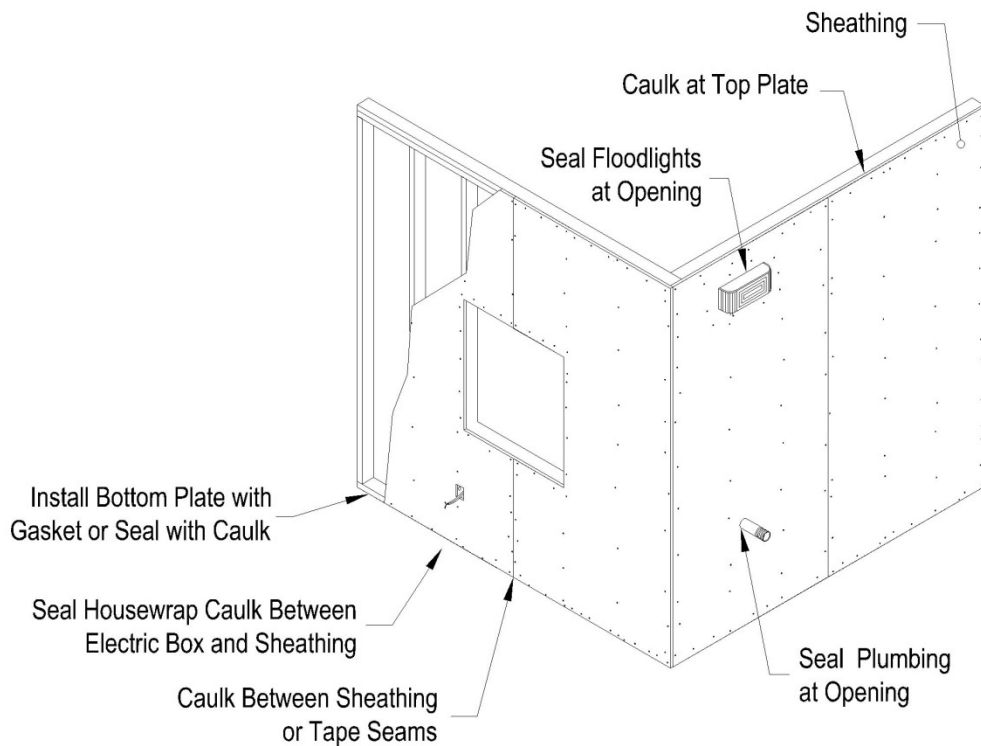

Figure 4 – 2 Sealing Exterior Barrier

HOUSEWRAPS

Housewraps serve as exterior air barriers, reducing air leakage through outside walls. Housewraps block only air leakage, not vapor diffusion, so they are not vapor barriers. Vapor barriers also do not substitute for air barriers. Housewrap products also shed water, so they help the wall drain water to the ground.

Typical products are rolled sheet materials that can be stapled and sealed to the wall between the sheathing and exterior finish material. For best performance, a housewrap must be sealed with caulk or tape at the top and bottom of the wall and around any openings, such as for windows, doors, and utility penetrations.

A key detail is proper installation of housewrap around window and door openings. Poor coordination of housewrap and window flashing installation will create problems for the homeowner. When the housewrap for the home is installed behind the flashing, rather than in front of it, the housewrap could then cause severe moisture problems. Because of this poor installation, water that penetrates the siding can run down the housewrap, behind the flashing, and into the wall framing.

Figure 4-3 shows how to effectively install a housewrap. Remember to always follow the directions provided by the manufacturer. In some instances, as shown in Figure 4-2, the exterior sheathing may be used as an outside air barrier. Careful sealing of all seams and penetrations is required.

When a housewrap is used as an exterior covering, it can add to the air leakage control of the house if it is properly installed, Figure 4-3. Follow the housewrap manufacturer's installation instructions and be careful to seal any joints in the wrap.

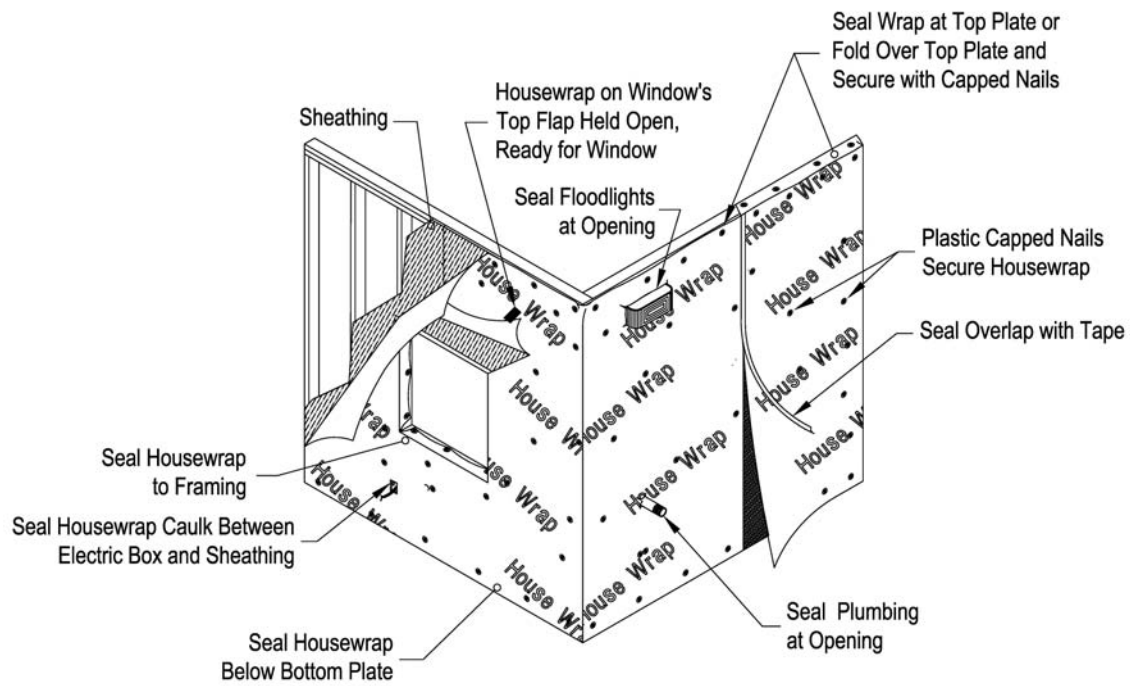

Figure 4 - 3 Housewrap

SEAL PENETRATIONS AND BYPASSES

The first step for successfully creating an air barrier system is to seal all of the holes in the building envelope. Too often, builders concentrate on air leakage through windows, doors, and walls, and ignore areas of much greater importance. Many of the key sources of leakage—called bypasses—are hidden from view behind soffits for cabinets, bath fixtures, dropped ceilings, chases for flues and ductwork, or insulation. Attic access openings and whole house fans are also common bypasses. Table 4-1 contains a list of common leaks and sealing methods.

Table 4-1 Leaks and Sealants

Type of Leak	Commonly Used Sealants
Thin gaps between framing and wiring, pipes or ducts through floors or walls	40-year caulking; one part polyurethane is recommended
Leaks into attics, cathedral ceiling, wall cavities above the first floor	Fire-stop caulking
Gaps, cracks or holes over 1/8" in width, not requiring fire-stop sealing	Gasket foam sealant or stuffed with fiberglass or backer rod, and caulk on top
Open areas around flues, chases, plenums, plumbing traps, etc.	Attach and caulk a piece of plywood or foam sheathing material that covers the entire opening. Seal penetrations. If a flue requires a noncombustible clearance, use a noncombustible metal collar, sealed in place to span the gap.
Final air barrier material	Use airtight drywall approach, continuous housewrap, or other air barrier system

Sealing these bypasses is critical to reducing air leakage in a home and maintaining the performance of insulation materials. The details that follow (Figure 4-4a and Figure 4-4b) show important areas that should be sealed to create an effective air barrier. The builder must clearly inform all subcontractors and workers of these details to ensure that the task is accomplished successfully.

Chapter 6 includes recommendations for properly sealing the area between the window or door assembly and the rough opening. Materials, such as fiberglass batt insulation, installed in that area are not effective for air sealing. Some type of material that can create an air seal and not cause the assembly to be distorted is needed, such as non-expanding foam insulation.

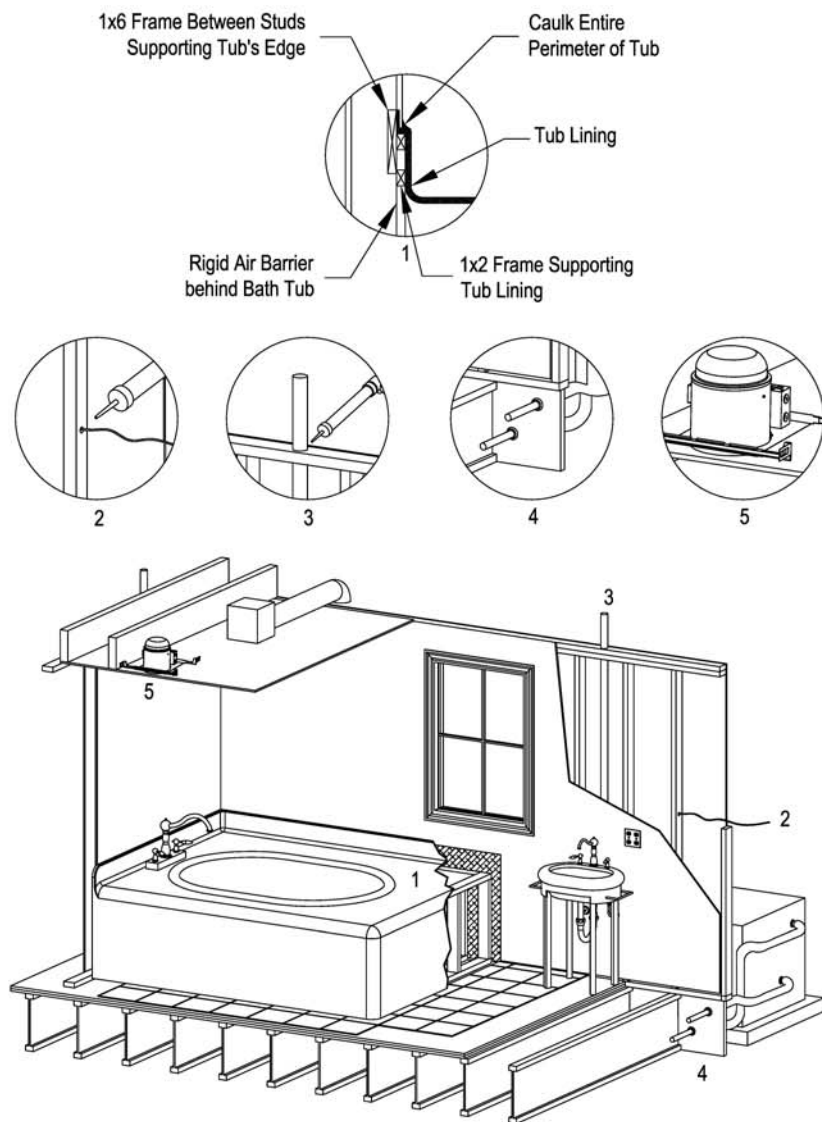

Figure 4 – 4a Wall Air Sealing and Insulation Details

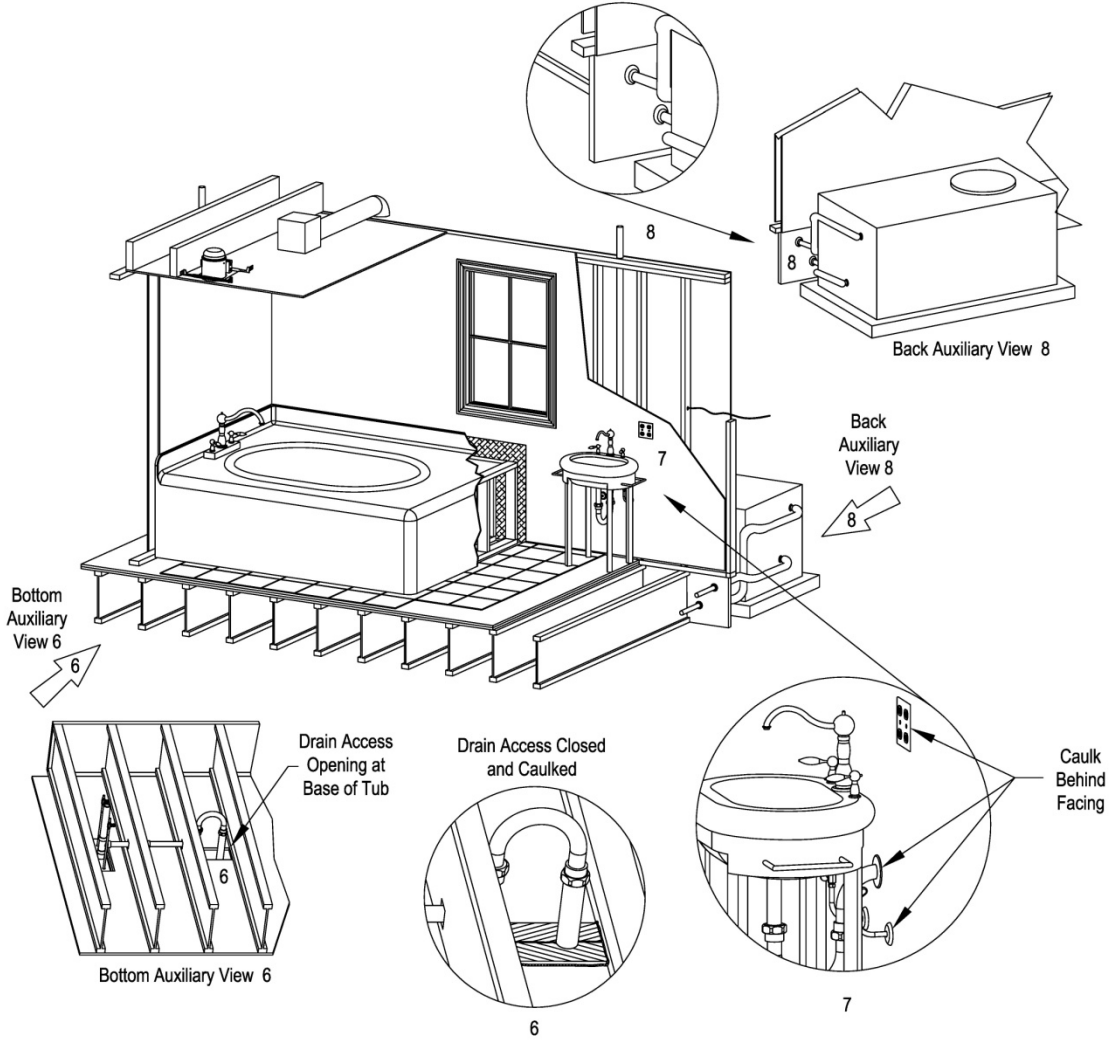

Figure 4 – 4b Wall Air Sealing and Insulation Details

The thermal bypass checklist required for an ENERGY STAR® certification requires that the wall behind a tub or shower, on an exterior wall, be insulated and covered with a waterproof air barrier, Figure 4-4a and Figure 4-4b. This not only reduces the air leakage, but it also improves the comfort of the tub.

When installing a dropped ceiling soffit in a kitchen or in bath/shower enclosures, a continuous air barrier at the attic floor must be provided to avoid a common air leakage area. The air barrier also provides a base for attic insulation. Figure 4-5 shows both the problems created when an air barrier is not installed above a soffit and the simple solution of providing an air barrier in that location.

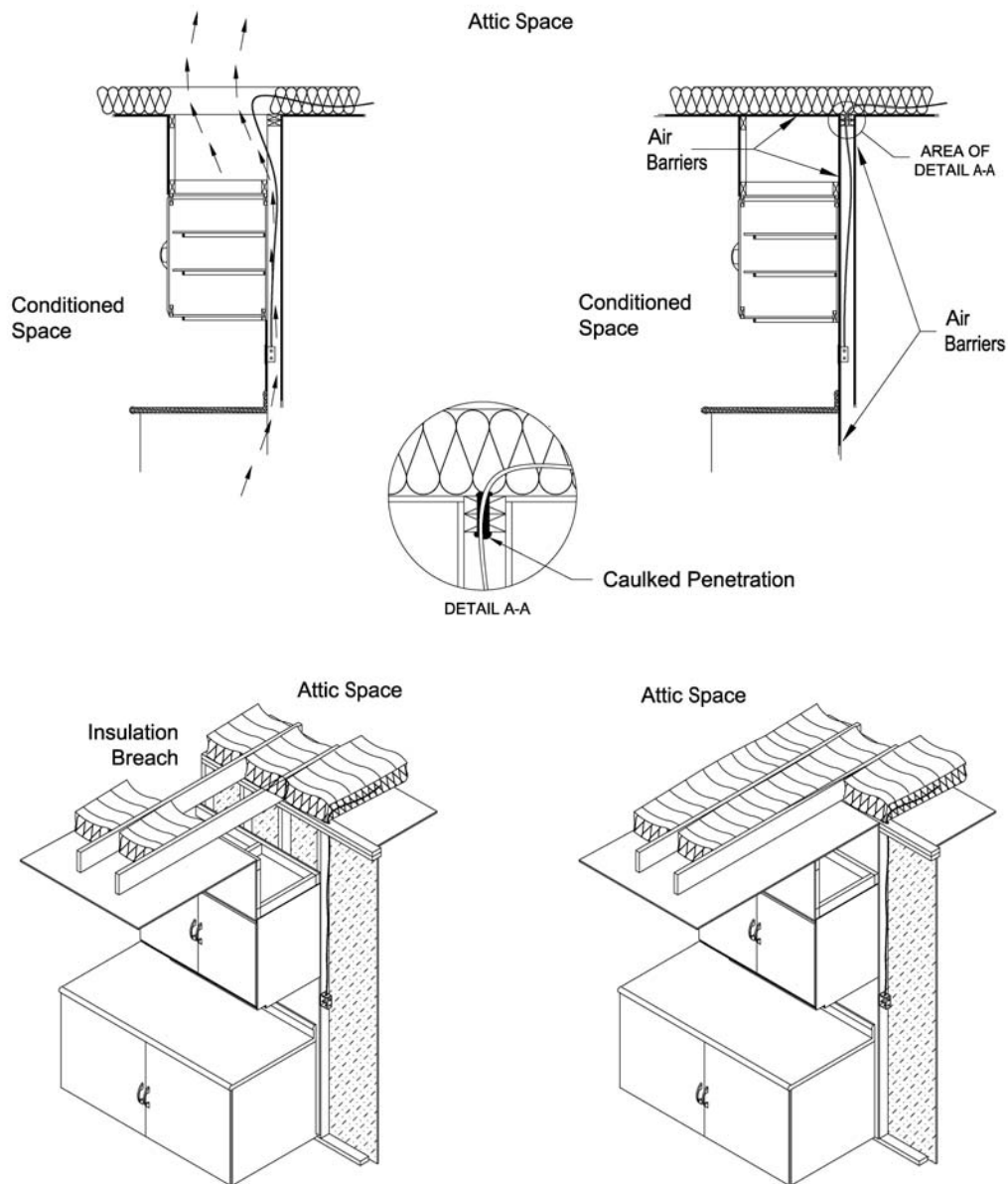

Figure 4 – 5 Dropped Soffit Air Leakage

Flue chases that penetrate the attic floor create special problems because of possible fire code restrictions. Framed chases for flues should be sealed at the attic floor, Figure 4-6. Seal between the flue and combustible materials with fire-rated caulk and a noncombustible flue collar.

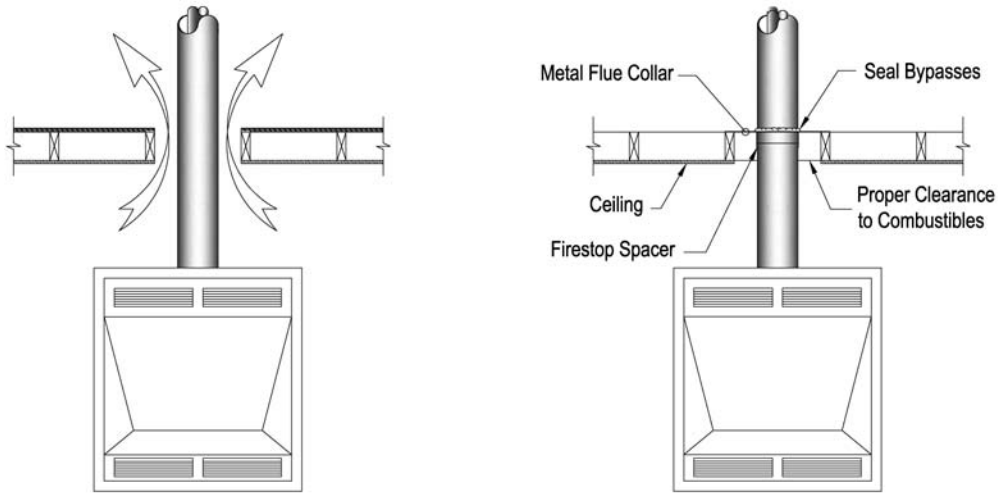

Figure 4 – 6 Sealing Bypasses for Flues

When return and supply plenums penetrate the floor or ceiling, shown in Figure 4-7, in unconditioned space, the penetration must be sealed. Whenever possible, the entire return and supply duct system should be installed inside the conditioned space of the house to avoid this situation.

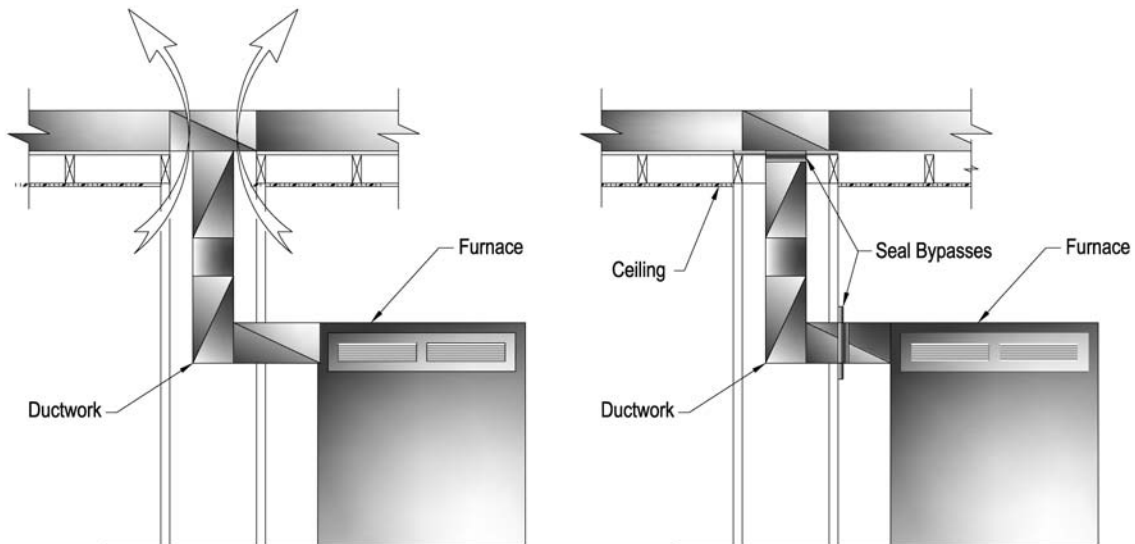

Figure 4 – 7 Seal Ductwork Bypasses

WEATHERSTRIPPING

In new home construction, most products come with weatherstripping installed. The most notable exception is the attic access panel, where weatherstripping must be installed. The attic access panels are typically just drop down panels (Figure 4-8), and a simple gasket material can be installed. The other location that weatherstripping needs to be checked is at the threshold under doors, to ensure that it is the proper height.

AIRTIGHT RECESSED LIGHTS

Any penetration of the building envelope represents a potential for air leakage. Recessed lights not only create such a penetration, but they also are installed at the highest point in the residence, in a location that enhances air loss by the stack effect. All recessed lights that penetrate the building envelop need to be airtight rated. See Chapter 10 for more details.

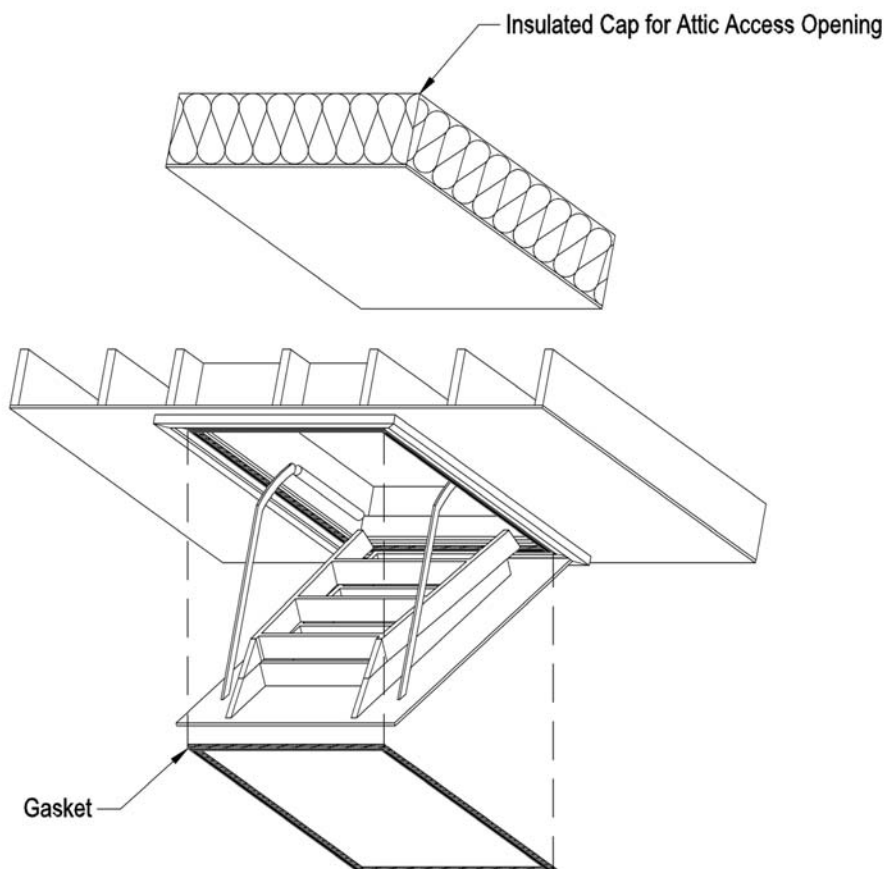

Figure 4 – 8 Barrier Control for Attic Access

AIRTIGHT DRYWALL APPROACH

The Airtight Drywall Approach (ADA) is an air sealing system that connects the interior finish of drywall and other building materials to form a continuous barrier. ADA has been used on hundreds of houses and has proven to be an effective technique to reduce air leakage as well as to keep moisture, dust, and insects from entering the home. The basics of an ADA are shown in Figure 4-9.

In a typical drywall installation, most of the seams are sealed by tape and joint compound. However, air can leak in or out of the home in the following locations:

- Between the edges of the drywall and the top and bottom plates of exterior walls;
- From inside the attic down between the framing and drywall of partition walls;
- Between the window and door frames and drywall; and
- Through openings in the drywall for utilities and other services.

ADA uses either caulk or gaskets to seal these areas and to make the drywall a continuous air barrier system.

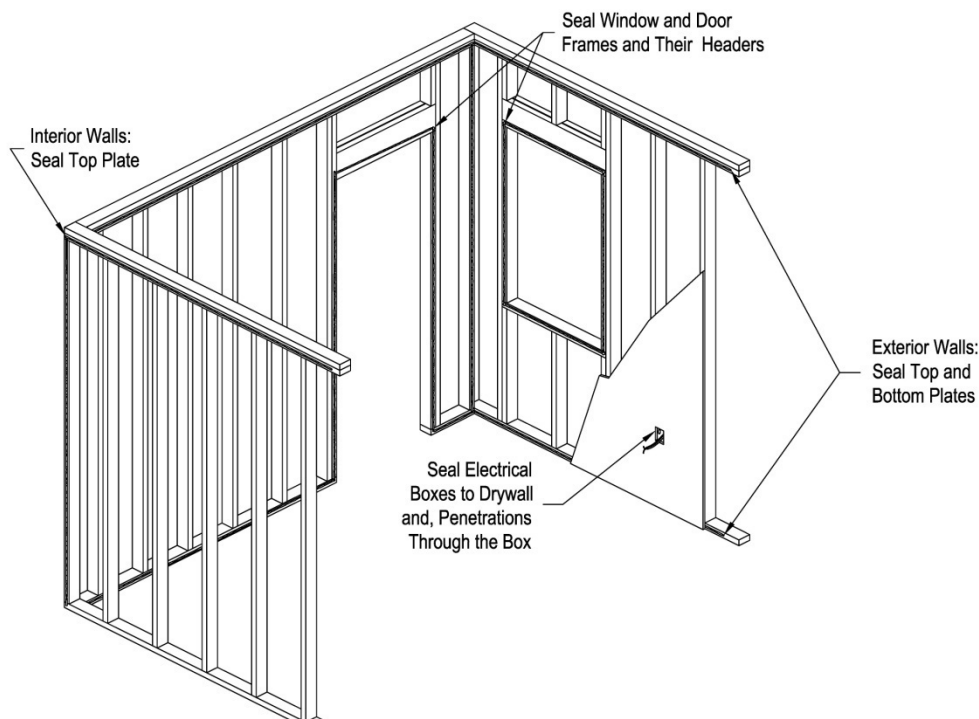

Figure 4-9 Airtight Drywall Approach

ADA ADVANTAGES

Effective—ADA has proven to be a reliable air barrier.

Simple—ADA does not require specialized subcontractors or unusual construction techniques. If gasket materials are not available locally, they can be shipped easily.

Does not cover framing—the use of ADA does not prevent the drywall from being glued to the framing.

Scheduling—gaskets can be installed anytime between when the house is “dried-in” and the drywall is attached to framing.

Adaptable—builders can adapt ADA principles to suit any design and varying construction schedules.

Cost—materials and labor for standard designs should only cost a few hundred dollars.

ADA DISADVANTAGES

New—although ADA is a proven technique, many building professionals and code officials are not familiar with its use.

Not a vapor barrier—not required in Climate Zone 4 but if required, a separate vapor barrier must be used with ADA.

Requires thought—while ADA is simple, new construction techniques require careful planning to ensure that the air barrier remains continuous. However, ADA is often the most error-free and reliable air barrier for unique designs.

Requires care—gaskets and caulking can be damaged or removed by subcontractors when installing the drywall or utilities.

ADA INSTALLATION TECHNIQUES

Exterior framed walls

- Install ADA gaskets or caulk along the face of the bottom plate so that when drywall is installed it compresses the sealant to form an airtight seal against the framing. Some builders also caulk the drywall to the top plate to reduce leakage into the wall.
- Use drywall joint compound or caulk to seal the gap between drywall and electrical boxes. Install foam gaskets behind cover plates and caulk holes in boxes.

Partition walls

- Install gaskets or caulk on the face of the first stud in the partition wall. Sealant should extend from the bottom to the top of the stud to keep air in the outside wall from leaking inside.

Windows and doors

- Seal drywall edges to either framing or jambs for windows and doors.
- Caulk window and door trim to drywall with clear or paintable sealant.

Ceiling

- When installing ceiling drywall, do not damage ADA gaskets, especially in tight areas such as closets and hallways.
- Avoid recessed lights; where used, install airtight, IC-rated fixtures and caulk between fixtures and drywall.

MEASURING AIRTIGHTNESS

While there are many well-known sources of air leakage, virtually all homes have unexpected air leakage sites called bypasses. These areas can be difficult to find and correct without the use of a blower door (see Figure 4-10). This diagnostic equipment consists of a temporary door covering, which is installed in an outside doorway, and a fan which pressurizes (forces air into) or depressurizes (forces air out of) the building. When the fan operates, it is easy to feel air leaking through cracks in the building envelope.

Most blower doors have gauges that can measure the relative leakiness of a building.

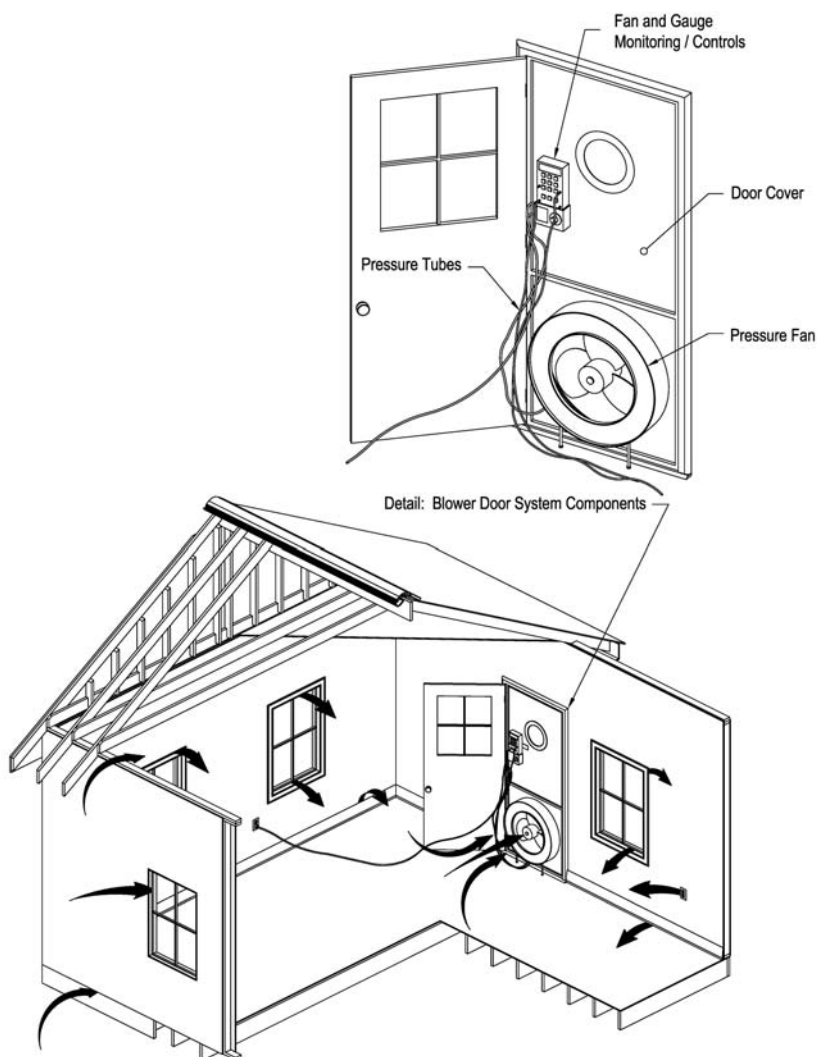

Figure 4 – 10 Blower Door System Operation



One indicator of a home's leakage rate is air changes per hour (ACH), which estimates how many times in one hour the entire volume of air inside the building leaks to the outside. For example, a home that has 2,000 square feet of living area and 8-foot ceilings has a volume of 16,000 cubic feet. If the home has an infiltration rate of 0.5 ACH, then the home leaks one-half of its volume per hour or 8,000 cubic feet per hour. The leakier the house, the higher the number of air changes per hour, the higher the heating and cooling costs, and the greater the potential for moisture, comfort, and health problems.

To determine the number of air changes per hour, many experts use the blower door to create a negative pressure of 50 Pascals. Fifty Pascals is approximately equivalent to a 20 mile per hour wind blowing against all surfaces of the building. In units commonly used in HVAC, 50 Pascals equals 0.20 inches of water pressure.

Energy efficient builders should strive for fewer than 0.25 air changes per hour under natural conditions (ACHnat). Table 4-2 compares the air changes per hour for different levels of home tightness. The table presents that data as ACH50, an estimate of the air changes per hour that would occur with a blower door, and naturally (ACHnat). ACHnat considers the number of stories in a home and the shielding provided by trees, hills or other buildings. The ACHnat value is most commonly used when home tightness is referenced.

Table 4-2 Typical Infiltration Rates for Homes (Air Changes per Hour)		
Type of Treatment	ACH50	ACHnat*
New home with special airtight construction and a controlled ventilation system	1.5 – 2.5	0.07 – 0.13
Energy efficient home with continuous air barrier system	4.0 – 6.0	0.20 – 0.30
Standard new home	7.0 – 15.0	0.35 – 0.75
Standard existing home	10.0 – 25.0	0.50 – 1.25
Older, leaky home	20.0 – 50.0	1.00 – 2.50

*The conversion between ACH50 and ACHnat is only an estimate.

CHAPTER 5: INSULATION: MATERIALS AND TECHNIQUES

An energy efficient building envelope contains both a thermal barrier and an air barrier. The key to an effective thermal barrier is proper installation of quality insulation products. A house should have a continuous layer of insulation around the entire building envelope. Studies show that improper installation can cut performance by 20% or more. While some types of insulation reduce air leakage, most do not, so always follow the guidelines in Chapter 4 to limit the air leakage potential as much as possible.

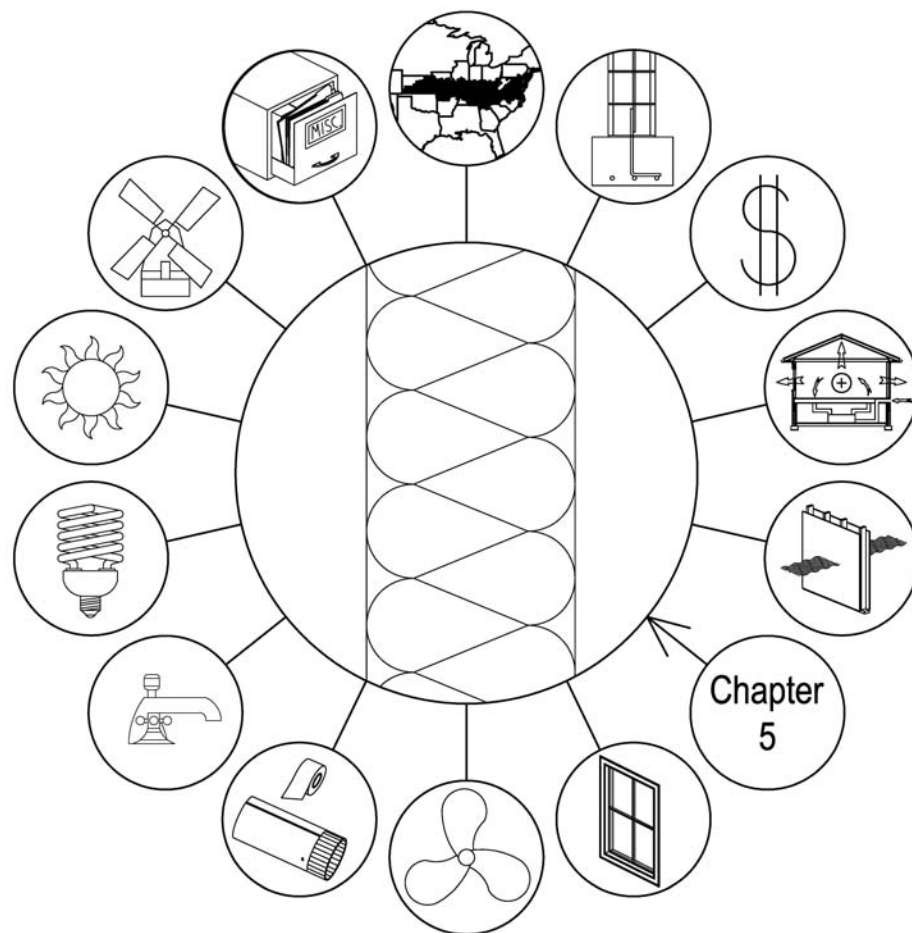

INSULATION MATERIALS

It can be confusing to try to characterize insulation because many materials come in a variety of forms. The insulation industry continues to develop new products to meet the increasing demand for specialized products.

FIBER INSULATION

- Fiberglass products come in batt, roll and loose-fill form, as well as a high-density board material. Many manufacturers use recycled glass in the production process. Fiberglass is used for insulating virtually every building component, from foundation walls to attics to ductwork.
- Cellulose insulation, made from recycled newsprint, comes primarily in loose-fill form. Loose-fill cellulose is used for insulating attics and can be used for walls and floors when installed with a binder or netting. Because of its high density, cellulose has the advantage of helping stop air leaks in addition to providing insulation value.
- Rock and mineral wool insulation is mainly available as a loose-fill product. It is fireproof and many manufacturers use recycled materials in the production process.

FOAMS

- Extruded polystyrene (XPS), a foam product, is a homogenous polystyrene produced primarily by three manufacturers with characteristic colors of blue, pink, and green.
- Polyisocyanurate and polyurethane are insulating foams with some of the highest available R-values per inch. They are not designed for use below-grade, unlike the polystyrene foam insulation products.
- Open-cell polyurethane foam is used primarily to seal air leaks and provide an insulating layer.
- Polycynene foam, used primarily to seal air leaks and provide an insulating layer, is made with carbon dioxide rather than more polluting gases, such as pentane or hydro-chlorofluorocarbons (HCFC), used in other foams.

INSULATION AND THE ENVIRONMENT

There has been considerable study and debate about potential negative environmental and health impacts of insulation products. These concerns range from detrimental health effects for the individual installer to depletion of the earth's ozone layer.

Concerns exist when the individual installer breathes in fiberglass and mineral wool fibers; as yet, there is no accepted universal proof that either is a carcinogen. Using cellulose raises flammability issues. However, fire retardant chemicals are added to cellulose; this, along with its greater density, provides the same or greater fire safety when compared to other insulation products. For years, foam products contained CFCs, which are the blowing agents, which helped create the lightweight foams. CFCs are quite detrimental to the earth's ozone layer. Blowing agents now used are pentane, HCFCs or carbon dioxide.

Expanded polystyrene uses pentane. Pentane has no impact on the ozone layer, but has been implicated in increasing smog formation. The insulation materials of extruded polystyrene, polyisocyanurate and polyurethane use primarily HCFCs. These are 90% less harmful to the ozone layer than CFCs. Some



companies are moving to non-HCFC blowing agents. Finally, open-cell polyurethane uses carbon dioxide as a blowing agent. The carbon dioxide does not affect the ozone layer unlike other blowing agents.

For additional information about these and other insulation materials, see Table 5-1. An R-value is a measure of the thermal resistance of a material. Higher R-values indicate better resistance to heat flow through material.

Table 5-1 Comparison of Insulation Materials (Environmental Characteristics, Health Impacts)			
Type of Insulation	Installation Method(s)	R-value per inch	Indoor Air Quality Impacts
<i>Fiber Insulation</i>			
Cellulose	Loose-fill, wet-spray dense pack, stabilized	3.0 – 3.7	Fibers and chemicals can be irritants, should be isolated from interior space
Fiberglass	Batts, loose-fill, stabilized, rigid board	2.2 – 4.0	Fibers and chemicals can be irritants, should be isolated from interior space
Mineral Wool	Loose-fill, batts	2.8 – 3.7	See fiberglass
<i>Foam Insulation</i>			
Open-cell Expanded Polystyrene (beadboard)	Rigid boards	3.6 – 4.2	Concern only for those with chemical sensitivities
Closed-cell Extruded Polystyrene	Rigid boards	5	Concern only for those with chemical sensitivities
Closed-cell Polyisocyanurate	Foil-faced rigid boards	5.6 – 7.7	Concern only for those with chemical sensitivities
Closed-cell Phenolic Foam	Foil-faced rigid board	8	Concern only for those with chemical sensitivities
Open-cell Polycynene	Sprayed-in	3.6	
Open-cell Soy-based Foam	Sprayed-in	3.6	
Closed-cell Polyurethane	Sprayed-in	5.6 – 6.8	Concern only for those with chemical sensitivities
Open-cell Polyurethane	Sprayed-in	4.3	Unknown, appears to be very safe

INSULATION STRATEGIES

Commonly used fiberglass and cellulose products are the most economical, while foam products should be used more judiciously. However, the wide variety of spray-foam products now on the market warrants serious consideration in many homes. In attics, loose-fill products are less expensive than batts or blankets. Blown cellulose and rock wool are denser than fiberglass, which helps them stop air leaks.

Critical guidelines for installing any insulating material are:

- Seal all air leaks between conditioned and unconditioned areas;
- Obtain complete coverage of the insulation;
- Minimize air leakage through the material;
- Avoid compressing insulation to less than its rated thickness;
- Avoid lofting (installing too much air) in loose-fill products; and
- Avoid thermal bridging.

FIBER INSULATION STRATEGIES

Fiber insulation requires care during installation to prevent compression. When installed, fiber insulation must have an air barrier on all six sides to meet the requirements of the ENERGY STAR® Thermal By-pass Checklist. The only exceptions are the horizontal surfaces in attics and when touching the floor in a crawl space. Common problems with fiber insulation installations are:

- Not cutting batts around wiring and plumbing in walls;
- Not installing an air barrier on the attic side of a knee wall; and
- Not creating an air barrier on all six sides of the floor insulation below a room over a garage.

FOAM INSULATION STRATEGIES

Foam products are primarily economical when applied in thin layers as part of a structural system. Foam products are a good choice to help seal air leaks.

Examples of appropriate locations to apply foam insulation products include:

- Foundation wall or slab insulation;
- Exterior sheathing over wall framing;
- Forms in which concrete can be poured;
- As part of a structural insulated panel for walls and roofs; and
- As part of complex framing in which fiber insulation would be difficult to install.

FOUNDATION INSULATION

Insulating the foundation of a residence is more difficult than insulating most other areas of a residence because of the environment surrounding the insulation. If the insulation is below grade, then it must resist the pressure of the soil, provide drainage if needed, and be termite resistant. If the insulation is external to the foundation and above grade, then some method of providing protection from mechanical damage (weed eaters, etc.), must be provided. In the case of brick siding, the builder must use some method of insulating the stem wall.

While insulating the interior of a foundation eliminates some of these difficulties, it presents its own unique problems. These problems include:

- Preventing air from reaching the concrete foundation wall, causing condensation;
- Ensuring that the insulation meets fire codes; and
- Determining how it can be finished.

Carefully consider the options provided in the following sections to ensure that a complete solution is possible in each specific residence. Table 5-2 provides some information on the economics of insulating basement walls to the prescriptive level in the 2006 IRC.

Table 5-2 Economics of Foundation Insulation Systems

Type of Treatment	Energy Savings * (\$/yr)	Break-even Investment‡ (\$)
<i>Masonry Wall</i>		
R – 4 continuous vs. R–0	208	1,377
R – 10 continuous vs. R–4	71	819
*For 1,000 sq ft of wall in Lexington, KY; energy savings are compared to an R – 4 concrete block wall.		
‡ See Chapter 2 for information on break-even investment.		

SLAB-ON-GRADE INSULATION

In many homes, the bottom-heated floor is a concrete slab-on-grade, meaning that a slab, situated near ground level, serves as the floor itself. Uninsulated slabs lose considerable heat in winter through their perimeter.

TERMITE PROBLEMS IN SLAB INSULATION

While slab insulation reduces energy bills, care must be taken because termites can burrow undetected through slab insulation to gain access to the wood framing above. The industry is working on solutions to the termite problem, but in the meantime, check with pest control companies to ensure termite contracts are valid for insulated perimeter slabs.

PREVENTING TERMITE PROBLEMS

Preventing termite problems is a key goal of any building, especially where a visual inspection of the foundation is not possible. Some important preventive measures are:

- Create good drainage—slope soil away from the home and install foundation drains.
- Remove organic matter—remove all wood from around the foundation before backfilling.
- Direct moisture away from the home—use well maintained gutters and downspouts that connect to a drainage system.
- Provide continuous termite shields—protect wooden sill plate and other framing members. The sill plate should be made of termite resistant lumber.
- Treat soil—make certain to hire a reputable termite company that will provide a full guarantee against pests. Install termite traps or other monitoring methods so that the occupants can see if pests are around the building.

SLAB INSULATION DETAILING

Detailing perimeter slab insulation should be planned carefully to prevent both aesthetic and moisture problems, see Figure 5-1 and Figure 5-2. The goals of detailing work are to blend foundation exterior finish with framed wall finish, prevent moisture problems, and create at least 2 feet of continuous perimeter insulation. Once again, make certain your termite contract covers homes with slab insulation.

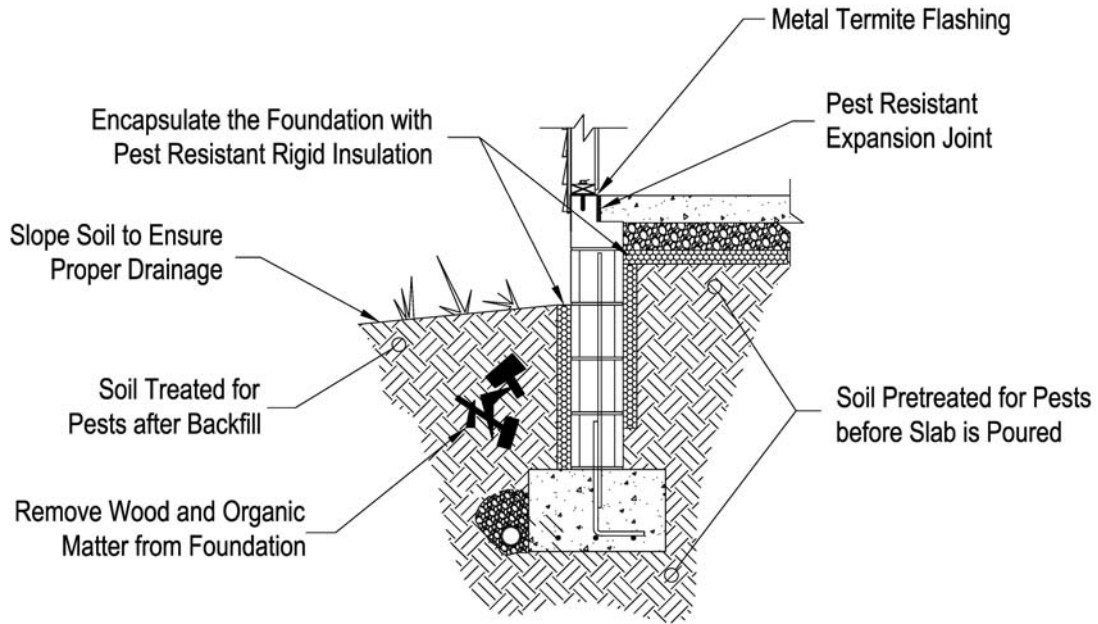

Figure 5 - 1 Exterior Insulation of Termite Retardants

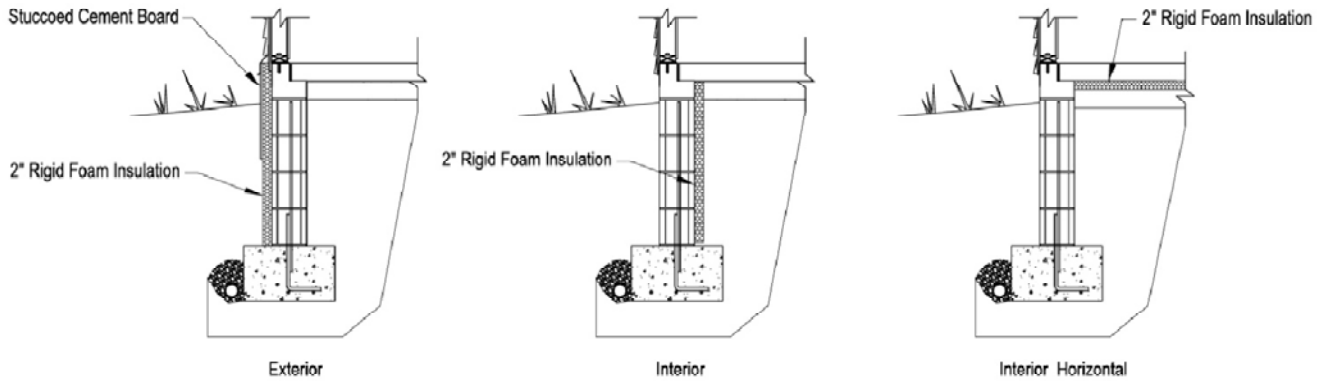

Figure 5 – 2 Slab Insulation Placement Options

FOUNDATION WALL INSULATION

Builders use concrete block or poured concrete to build foundation walls and other masonry walls. Insulating foundation walls is more difficult than insulating framed walls; there is no convenient cavity into which insulation can fit.

EXTERIOR RIGID FIBERGLASS OR FOAM INSULATION

Rigid insulation is more expensive than mineral wool or cellulose; however, its rigidity is a major advantage (Figure 5-3). Rigid insulation can be placed directly over a foundation wall prior to backfilling and yields excellent insulating value. In addition, the exterior insulation will help protect waterproofing and will allow the block or concrete wall to provide thermal mass in winter and summer.

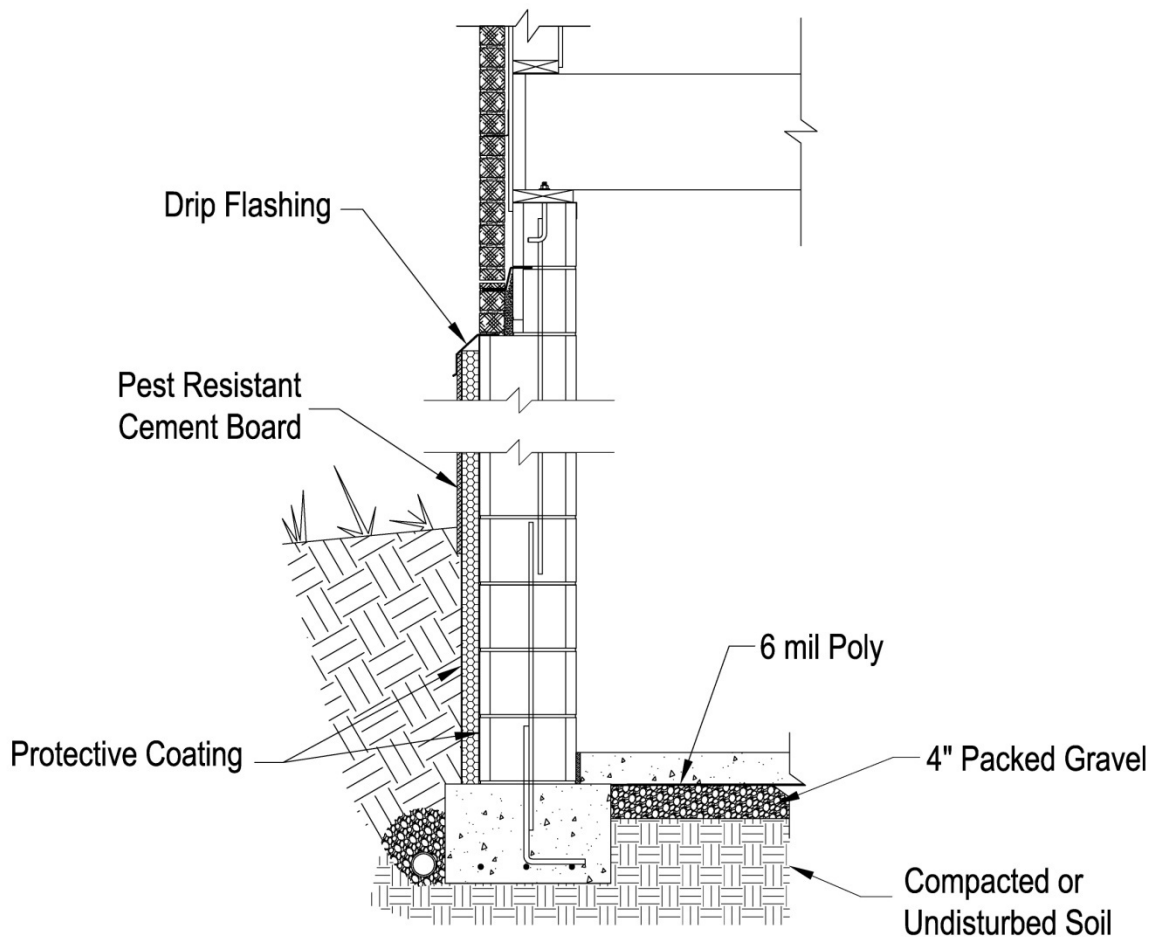

Figure 5 - 3 Exterior Rigid Foam Insulation

INTERIOR FOAM WALL INSULATION

Foam insulation can be installed on the interior of foundation walls, but it must be covered with a material that resists damage and meets local fire code requirements, as in Figure 5-4. Half-inch drywall will typically comply, but furring strips will need to be installed as nailing surfaces. Furring strips are usually installed between sheets of foam insulation; however, to avoid the direct, uninsulated thermal bridge between the concrete wall and the furring strips, a continuous layer of foam should be installed underneath or on top (preferred placement) of the nailing strips.

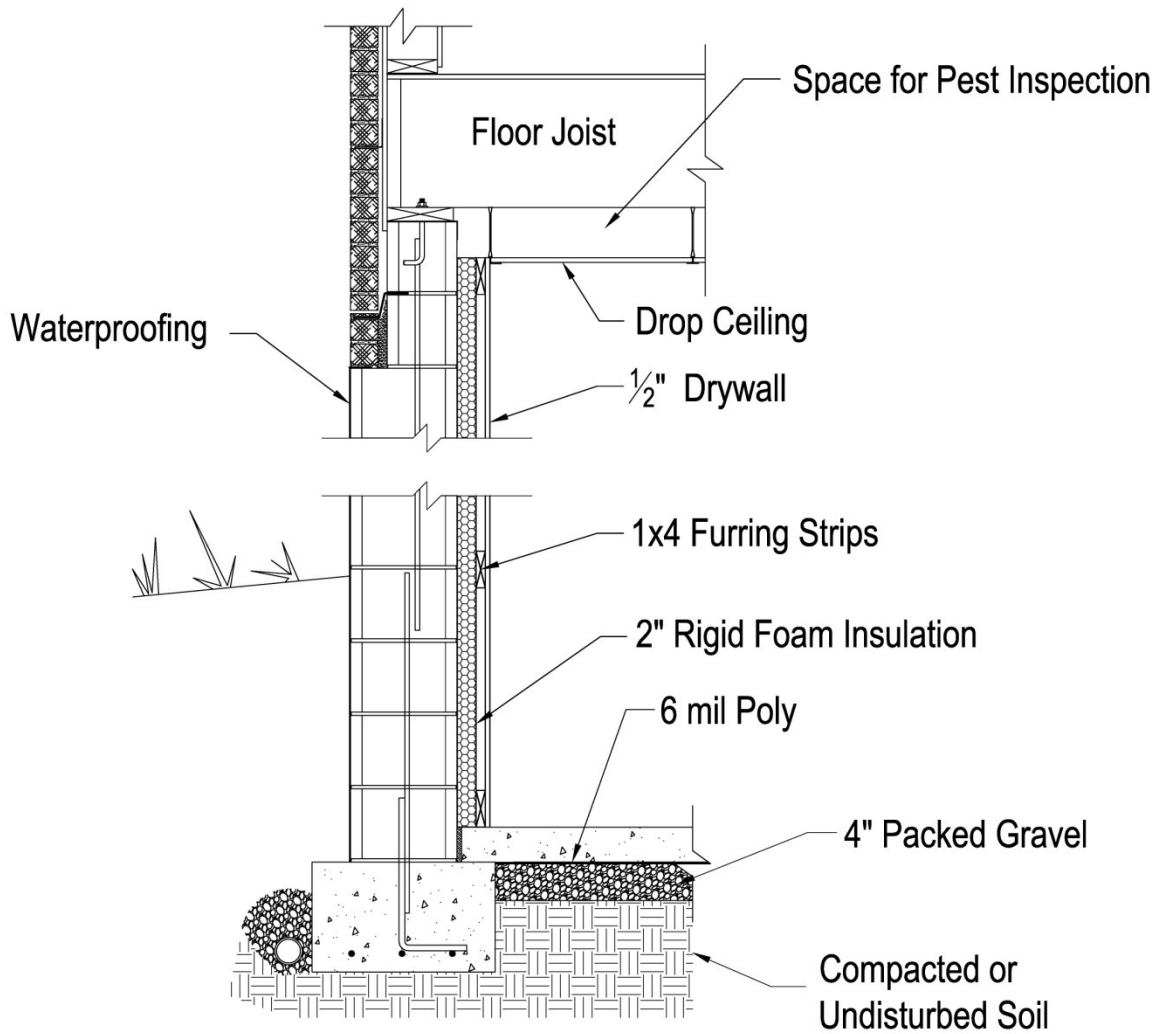

Figure 5 - 4 Interior Basement Wall Insulation (R - 10 to R - 14)

INTERIOR FRAMED WALL

In some cases, designers will specify a framed wall on the interior of a masonry wall, Figure 5-5. The wall should include provisions for both continuous insulation and careful air sealing. If a continuous insulation layer is not provided between the wall and the block, air sealing is critical. If warm moist air leaks into that area it will condense on the wall and create conditions that promote mold growth.

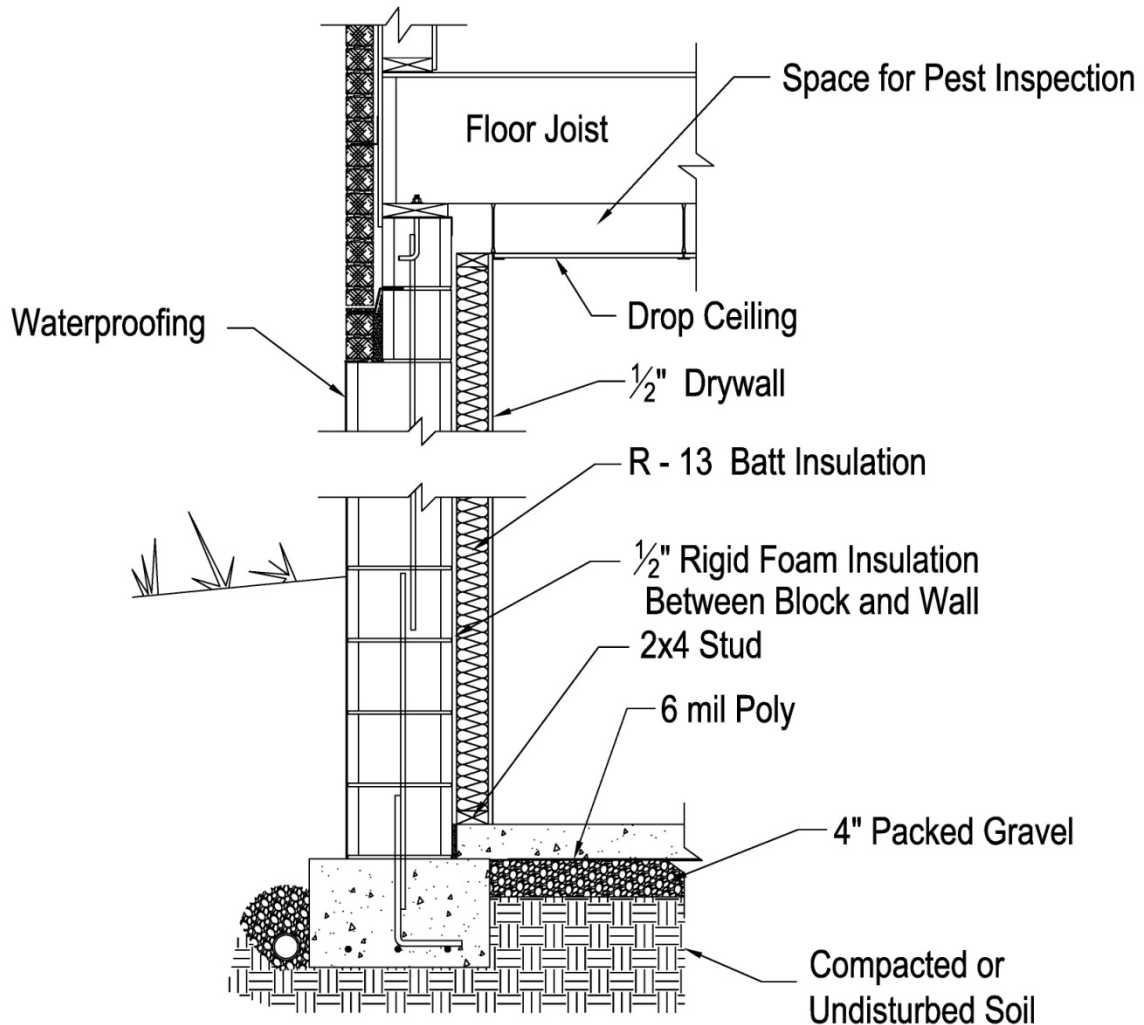

Figure 5 – 5 Interior Framed Wall Insulation (R – 13 Cavity)

INSULATED CONCRETE FOUNDATION (ICF) SYSTEMS

Foam insulation systems, which serve as formwork for concrete foundation walls, can help the builder save on materials and can cut heat flow. Once stacked, reinforced with rebar, and braced, they can be filled with concrete.

Key considerations are:

- *Bracing requirements:* bracing the foam blocks before construction may outweigh any labor savings from the system. However, some products require little bracing.
- *Stepped foundations:* make sure of the recommendations for stepping foundations. Some systems have 12-inch high blocks or foam sections, while others are 16-inch high.
- *Reinforcing:* follow the manufacturer's recommendations for placement of rebar and other reinforcing materials.
- *Concrete fill:* make sure that the concrete ordered to fill the foam foundation system has sufficient slump to meet the manufacturer's requirements. These systems have been subject to blow-outs when the installer did not fully comply with the manufacturer's specifications. A blow-out is when the foam or its support structure breaks and concrete pours out of the form.
- *Waterproofing:* many standard waterproofing treatments, which use organic compounds, will degrade the foam insulation that make up the insulated forms. Follow the manufacturer's guidelines regarding safe and effective waterproofing products and techniques.
- *Termites:* these systems may require approval by code inspection officials. Also, be sure to consult with a reputable termite contractor.

INSULATING CRAWL SPACE WALLS

For years, building professionals have assumed that the optimal practice for insulating floors over unheated areas was to insulate underneath the floor. However, studies have found that insulating the walls, in well-sealed crawl spaces can be an effective alternative to underfloor insulation. Because the crawl space remains cool in summer, the home can conduct heat to the crawl space if there is no insulation under the floor. Homes with sealed and insulated crawl space walls must also have a completely sealed ground cover system, typically using polyethylene, see Figures 5-6 and 5-7.

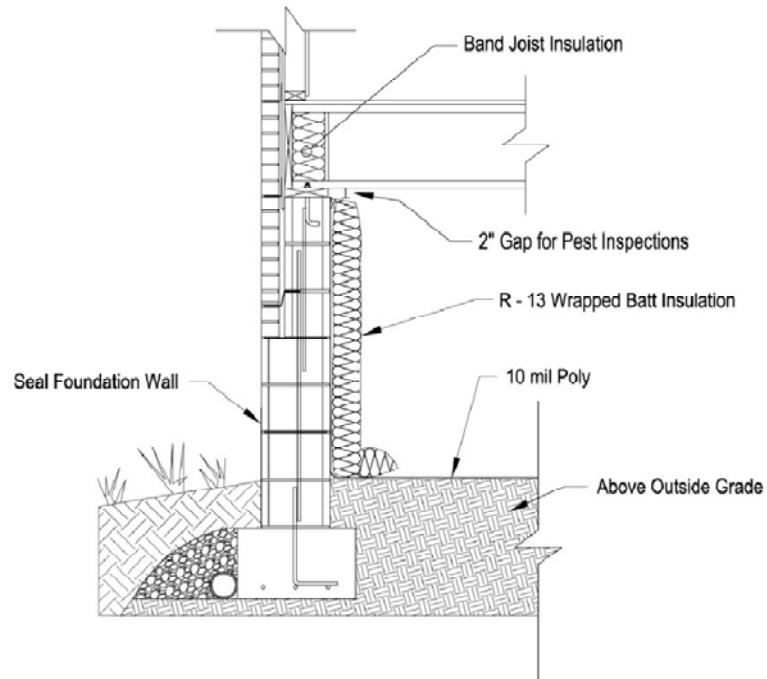

Figure 5 - 6 Insulated Crawl Space Wall

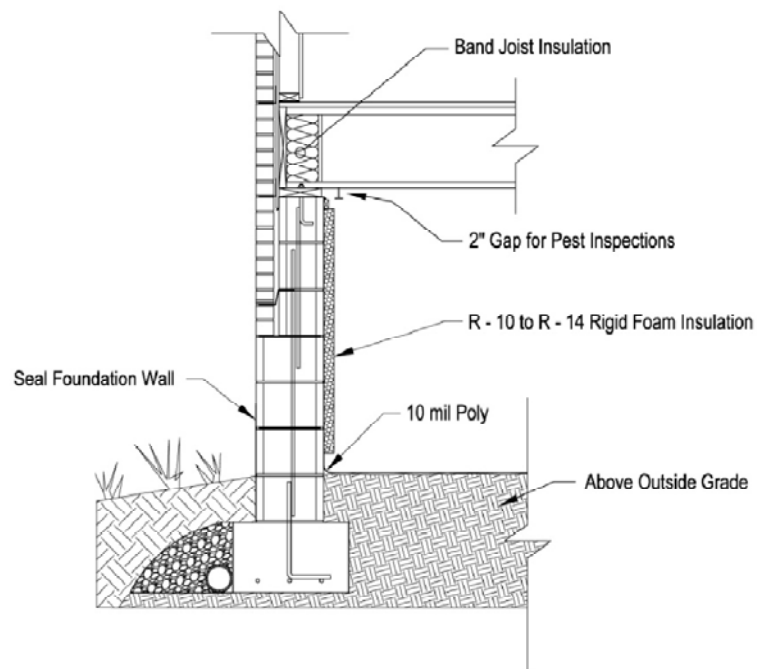

Figure 5 - 7 Insulated Crawl Space Wall

SEALED CRAWL SPACE VENTILATION REQUIREMENTS

- The International Residential Code specifies that the crawl space requires one of the following for crawl spaces without foundation vents:
 - Ventilation fan that either exhausts or supplies 1 cfm of air per 50 square feet of crawl space floor, or
 - Supply air from the heating and cooling system equal to 1 cfm of air per 30 square feet of crawl space floor.
- Furnaces or water heaters that are located in these areas and require outside air for combustion should have a direct inlet duct from the outside.

SEALED CRAWL SPACE WALL INSULATION REQUIREMENTS

- Cover the earth floor with 6-10 mil polyethylene (recommended in all homes). Seal all seams in the plastic with caulk or mastic (typically used for duct sealing). Lap the plastic up the foundation wall until above outside grade and seal it against the wall. Do not install foundation vents.
- Leave a 1 or 2 inch gap at the top of the insulation to serve as a termite inspection strip.
- Insulate the band joist area, in addition to the foundation wall.
- Seal carefully between the crawl space or basement and the house interior.
- Builders should review plans for the insulation with local building officials to ensure code compliance.

Advantages of crawl space wall insulation:

- Less insulation required (around 800 square feet for a 2,000 square foot crawl space with 4-foot walls instead of 2,000 square feet of R-19 under the floor);
- Pipe insulation is not required (spaces should stay warmer in winter);
- Much lower humidity levels during warm weather; and
- Reduction in cooling load and cooling bills with only a slight increase in heating bills compared to crawl spaces with near perfect underfloor insulation.

Disadvantages of crawl space wall insulation:

- The insulation may be damaged by rodents and other pests;
- If the crawl space is leaky to the outside, the home will lose considerably more heat than standard homes with underfloor insulation; and
- If the site has improper drainage, the crawl space will be wet; therefore, proper site drainage is essential for a dry crawl space.

INSULATING UNDER FLOORS

Most floors in conventional homes are constructed with 2x10 or 2x12 wood joists, wood I-beams, or trusses over unconditioned crawl spaces or basements. Generally, insulation is installed underneath the subfloor between the framing members. To meet the 2006 IRC prescriptive guidelines for Climate Zone 4, homes need R-19 floor insulation.

Most builders use insulation batts for insulating framed floors. The batts should be installed flush against the subfloor to eliminate any gaps that may serve as a passageway for cold air between the insulation and floor.

Most insulation contractors use special rigid wire supports to hold the insulation in place. For the insulation to stay in place over several decades, installers must carefully install the wire supports 16 inches apart (Figure 5-8).

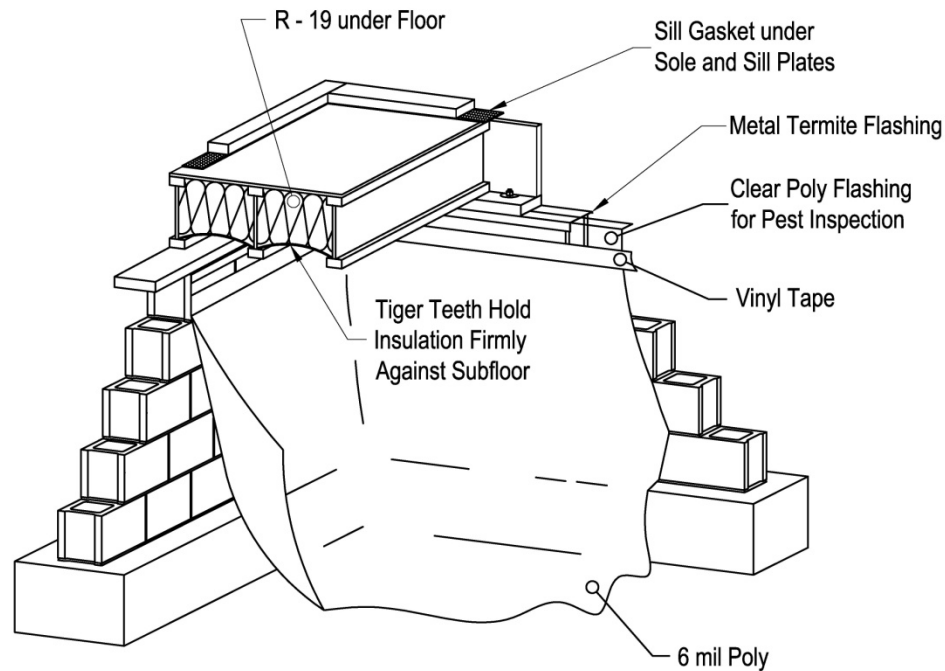

Figure 5 – 8 Insulated Wood Framed Floor

The framed floor area above a garage represents a special case for insulation to meet the thermal bypass requirements for ENERGY STAR® Certification. Insulation in this location must fully fill the space between the floor and the sheet rock ceiling of the garage. In addition, some method of blocking must be provided at the ends, if the insulation does not extend the entire width of the garage.

INSULATING WALLS

To solve some of the energy and moisture problems in standard wall construction, builders should follow the key components for energy efficient construction discussed in Chapter 1. Some of these features involve preplanning, especially the first time that these energy efficient improvements are used. In addition to standard framing lumber and fasteners, the following materials will also be required during construction:

- Foam sheathing for insulating headers;
- 1x4 or metal T-bracing for corner bracing;
- R-13 batts for insulating behind shower/tub enclosures and other hidden areas during framing;

- Rigid material for sealing behind shower/tub enclosures and other areas that cannot be reached after construction; and
- Caulking or foam sealant for sealing areas that may be more difficult to see later.

Enclosed cavities are more prone to cause condensation, particularly when sheathing materials, with low R-values, are used. Ensure that a continuous air barrier system is installed. The presence of wiring, plumbing, ductwork, and framing members lessens the potential R-value and provides pathways for air leakage. Locate mechanical systems in interior walls. Avoid horizontal wiring runs through exterior walls and use an air sealing insulation system.

The interest in providing more energy efficient homes has created several new methods of insulating standard 2x4 walls. While the insulation cavity is limited to 3.5 inches thick, new methods can increase the R-value of the insulation or ensure that the placement is correct, no gaps or missed areas, or both. It is likely that new methods will continue to develop as long as 2x4 wall construction is common.

BATT INSULATION

While batt insulation in walls has been the standard for wall insulation, it has one primary drawback, the quality of the installation. Properly installed and protected by an air barrier on all six sides, batt insulation can perform as desired. Proper installation includes cutting the batts so that they can be installed around any materials in the wall cavity, such as electrical wiring or plumbing and avoiding side stapling.

Side stapling can compress the insulation and create an air space between the insulation and the interior finish, which allows cold air to circulate within the wall cavity (Figure 5-9). The combined effect of the compressed insulation and air circulation can substantially reduce the effective insulating value of an R-13 batt. Side stapling also results in the Home Energy Rater having to reduce the quality of the insulation, which results in a lower HERS score.

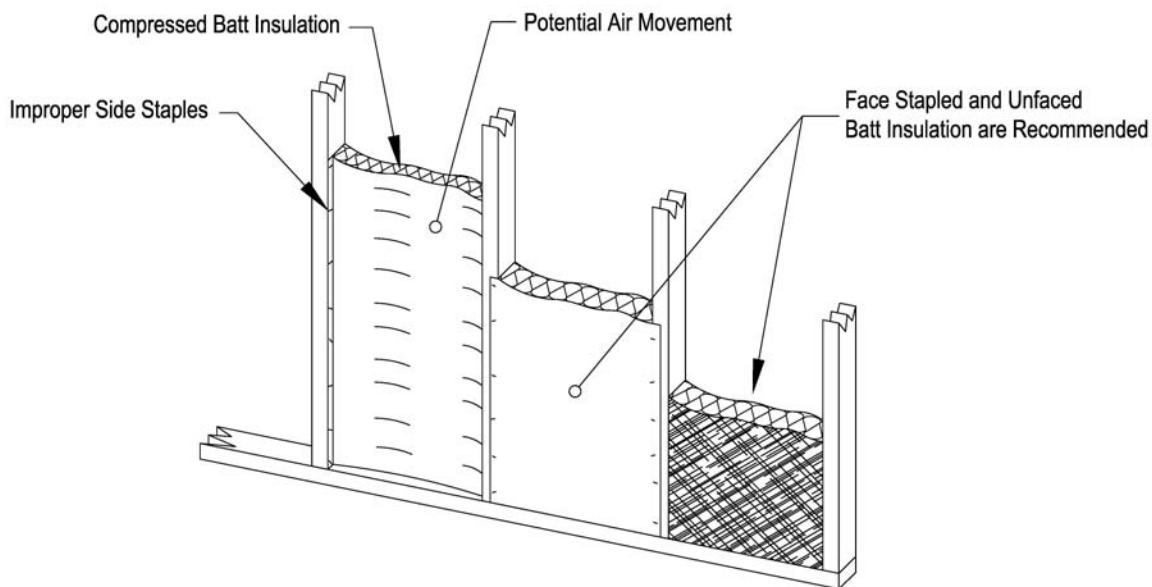

Figure 5 – 9 Insulation Materials and Techniques

The insulation flange is designed to be stapled to the face of the studs at 12 inch intervals. Face stapling the batt ensures that the insulation will completely fill the stud cavity and minimize air circulation. The facing typically has too many tears and seams to function as an adequate air barrier; however, it does serve as a vapor retarder.

An alternative to side stapling insulation batts with flanges is to use unfaced batts. They are slightly larger than the standard 16 or 24 inch stud spacing and rely on a friction-fit for support. Since unfaced batts are not stapled, they can often be installed in less time. In addition, it is easier to cut unfaced batts to fit around wiring, plumbing, and other obstructions in the walls.

BLOWN LOOSE-FILL INSULATION

Loose-fill cellulose, fiberglass, and rock wool insulation can also be used to insulate walls. These products are installed with insulation blowing machines and held in place with a glue binder or netting. Blown insulation provides good coverage in the stud cavities; however, it is important to allow excess moisture in the binder to evaporate before enclosing the wall cavities with a vapor barrier or interior finish.

Loose-fill materials with high densities, such as cellulose installed at 3 to 4 pounds per cubic foot, are not only excellent insulators, but also seal air leaks and reduce sound transmission. Some people get the cellulose almost as much for its sound deadening as for its insulation properties. Fiberglass is less dense than cellulose and does not provide as much resistance to air circulation. Therefore, builders must consider the additional benefits of air sealing when evaluating the economics of blown cellulose.

Neither unfaced insulation batts nor loose-fill products provide a vapor retarder. The 2006 IRC no longer requires vapor retarders in Climate Zone 4.

BLOWN FOAM INSULATION

Some insulation contractors are now blowing polyurethane or polyisocyanurate insulation into walls of new homes. This technique seals air leaks effectively and with closed-cell foams provides high R-values in relatively thin spaces. The builder should examine carefully the economics of foam insulation before deciding on its use.

METAL FRAMING

Builders and designers are well aware of the increasing cost and decreasing quality of framing lumber. Consequently, interest in alternative framing materials, such as metal framing, has grown. While metal framing offers advantages over wood, such as consistency of dimensions, lack of warping, and resistance to moisture and insect problems, it has distinct disadvantages from an energy perspective.

Metal framing serves as an excellent conductor of heat (Table 5-3). Homes framed with metal studs and plates usually have metal ceiling joists and rafters as well. Thus, the entire structure serves as a highly conductive thermal grid. Insulation placed between metal studs and joists is much less effective due to the extreme thermal bridging that occurs across the framing members.

Cavity Insulation R	Sheathing R	Effective Overall R-value
13	2.5	9.5
13	5	12
13	10	17
19	2.5	12.5
19	5	15

Researchers have delved into numerous ways to provide for a thermal break in walls with steel framing. The most effective solution has been to increase the insulating value of the sheathing. However, the home still suffers considerable conduction losses into the attic if the ceiling joists and rafters are steel-framed. The best solution to heat gain through steel framing in attics is to install a thermal break, such as a sill sealer material, between wall framing and ceiling joists. Then place a layer of foam sheathing underneath the ceiling joists before installing drywall.

STRUCTURAL INSULATED PANELS

Another approach to wall construction is the use of structural insulated panels (SIP), see Figure 5-10. They consist of 4- or 6-inch thick foam panels onto which sheets of structural plywood or oriented strand board (OSB) have been glued. These structured insulated panels reduce labor costs, and because of the reduced framing in the wall, have higher R-values and less air leakage than standard walls.

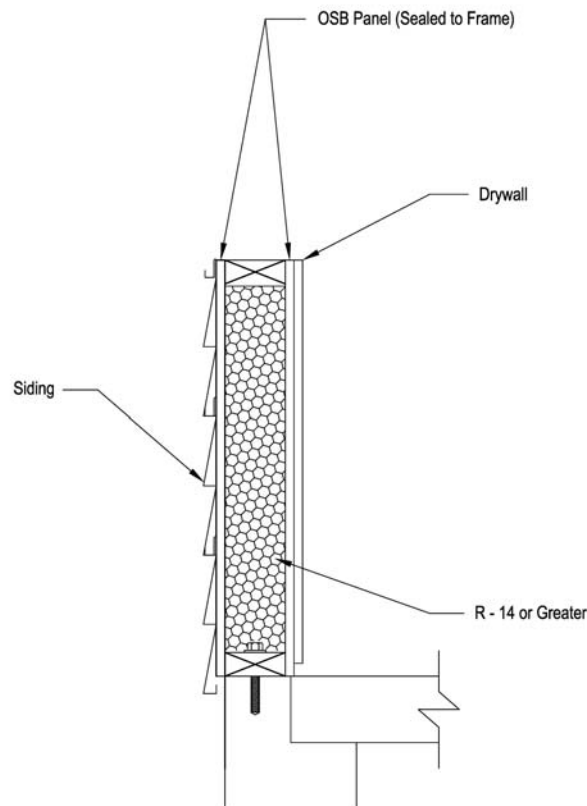

Figure 5 – 10 Structural Insulated Panel

SIPs are 4 feet wide and generally 8 to 12 feet long. There are many manufacturers, each with a unique method of attaching panels. Each manufacturer has worked out procedures for installing windows, doors, wiring, and plumbing. In addition to their use as wall framing, SIPs can also form the structural roof of a building.

While homes built with SIPs may be more expensive than those with standard framed and insulated walls, research studies have shown SIP-built homes have higher average insulating values and fewer air leaks. Thus, SIPs can provide substantial energy savings to balance the added costs.

WALL SHEATHINGS

Many of Kentucky's builders use ½-inch wood sheathing (R-0.6) to cover the exterior walls of a building before installing the siding. Instead, use expanded polystyrene (R-2), extruded polystyrene (R-2.5 to 3), polyisocyanurate or polyurethane (R-3.4 to 3.6) foam insulated sheathing. (All R-values are per ½ inch.)

The recommended thickness of the sheathing is based on the desired R-value and the jamb design for windows and doors, usually ½ inch. Be certain that the sheathing completely covers the top plate and band joist at the floor. Most manufacturers offer sheathing products in 9- or 10-foot lengths to allow

complete coverage of the wall. Once it is installed, patch all holes, which also helps to ensure protection against condensation.

Advantages of foam sheathing over wood or fiberboard include:

- Saves energy;
- Easier to cut and install;
- Protects against condensation; and
- Less expensive than plywood or OSB.

Disadvantage of foam sheathing over wood or blackboard:

- Requires the use of let-in bracing to provide structural support, Figure 5-11.

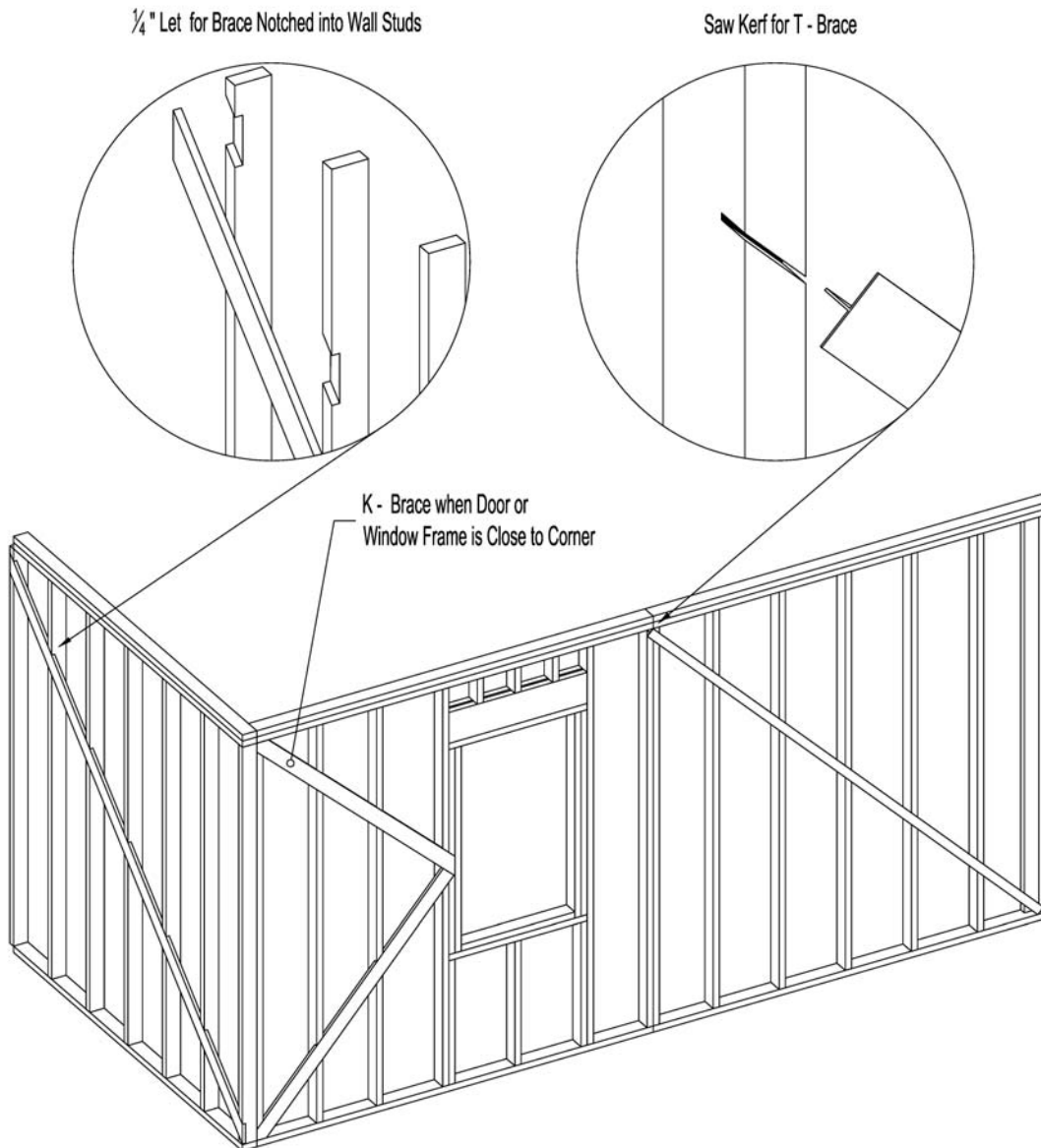

Figure 5 - 11 Rigid Foam Exterior Wall Bracing

2X6 WALL CONSTRUCTION

There has been considerable interest in Kentucky in the use of 2x6s for construction. In most code jurisdictions, 2x6s can be spaced on 24 inch centers, rather than the 16 inch centers required for 2x4s. The advantages of using wider wall framing are:

- More space provides room for R-19 or R-21 wall insulation;
- Thermal bridging across the studs is less of a penalty due to the higher R-value of 2x6s and wider stud spacing;
- Less framing reduces labor costs; and
- There is more space for insulating around piping, wiring, and ductwork.

Disadvantages of 2x6 framing include:

- Wider spacing may cause the interior finish or exterior siding to bow slightly between studs;
- Window and door jambs must be wider and can add \$12 to \$15 per opening; and
- Walls with substantial window and door area may require almost as much framing as 2x4 walls and leave relatively little area for actual insulation.

The economics of 2x6 wall insulation are affected by the number of windows in the wall, since each window opening adds extra studs and may require the purchase of a jamb extender. Table 5-5 shows a comparison of 2x4 versus 2x6 framing. Walls built with 2x6s, having few windows, provide a positive economic payback. However, in walls in which windows make up over 10% of the total area, the economics become more questionable.

Description of Wall	Average R-values	
	Wall Only	Average with Windows**
<i>No window</i>		
2x4	13.04	Same
2x6	19.00	Same
<i>2 windows</i>		
2x4	12.59	9.66
2x6	18.38	12.45
<i>4 windows</i>		
2x4	12.10	7.68
2x6	17.69	9.82

*400 sq ft with R – 13, 2x4 construction versus R – 19, 2x6 construction.
 **All windows are U – 0.40, 15 sq ft.

Selecting the combination of framing material, framing method, insulation level and sheathing to create the most energy efficient walls' system, that is economically feasible, is complicated by the number of options available. Table 5-6 lists 15 different combinations and shows the energy savings and break-even investment for each compared to standard 2x4 wall construction. Techniques, such as advanced framing, may not result in large energy savings but, because they use fewer materials, may actually result in no additional cost of construction.

Table 5-6 Economics of Wall Insulation Systems

Type of Treatment	Energy Savings*(\$/yr)	Break-even Investment‡ (\$)
2x4 Wall		
R – 13 batts, standard framing	0	
R – 13 batts, standard framing; R – 3 sheathing	57.00	641.71
R – 13 batts, advanced framing	10.00	112.58
R – 13 batts, advanced framing; R – 3 sheathing	62.00	698.00
R – 15 batts, standard framing	18.00	202.64
R – 15 batts, standard framing; R – 3 sheathing	69.00	776.80
R – 15 batts, advanced framing	29.00	326.48
R – 15 batts, advanced framing; R – 3 sheathing	75.00	844.35
2x6 Wall		
R – 19 batts, standard framing	77.00	866.87
R – 19 batts, standard framing; R – 3 sheathing	105.00	1,182.09
R – 19 batts, advanced framing	84.00	945.67
R – 19 batts, advanced framing; R – 3 sheathing	109.00	1,227.12
R – 21 batts, standard framing	86.00	968.19
R – 21 batts, standard framing; R – 3 sheathing	112.00	1,260.90
R – 21 batts, advanced framing	84.00	945.67
R – 21 batts, advanced framing; R – 3 sheathing	117.00	1,317.19
*For a 2,000 sq ft home with 1,774 sq ft of net wall area located in Lexington, KY.		
‡See Chapter 2 for information on break-even investment.		

CEILINGS AND ROOFS

Attics over flat ceilings are usually the easiest part of a home's exterior envelope to insulate. They are accessible and have ample room for insulation. However, many homes use cathedral ceilings that provide little space for insulation. It is important to insulate both types of ceilings properly. In addition, builders are beginning to insulate the roof deck to create a conditioned attic space. One benefit is to bring an HVAC system, installed in an attic, into a conditioned space to reduce duct loss.

ATTIC VENTILATION

In winter, properly designed roof vents expel moisture that could otherwise accumulate and deteriorate insulation or other building materials. In summer, ventilation reduces roof and ceiling temperatures, thus saving on cooling costs and lengthening the roof's life.

IS VENTILATION NECESSARY?

At present, building science experts are researching attic ventilation. For years, researchers have believed that the cooling benefits of ventilating a well-insulated attic are negligible. However, some experts are now questioning whether ventilation is even effective at moisture removal. While the 2006 IRC allows for an insulated roof deck, it does not allow for a sealed attic. Builders should follow local code requirements until alternatives to attic ventilation have been widely accepted and the IRC has accepted their use.

INSULATED ROOF DECKS

The 2006 IRC uses the term “unvented conditioned attic assemblies” to refer to what is commonly called an insulated roof deck. The 2006 IRC provides for insulated roof deck under specified conditions. These conditions do not apply if a 1 inch air space is provided between the insulation and the roof sheathing. This situation does not meet the definition of an insulated roof deck because it allows the attic to be vented, even though the insulation is close to the roof. The conditions for Climate Zone 4 include:

1. No interior vapor retarders are installed on the ceiling side (attic floor) of the unvented attic assembly.
2. An air-impermeable insulation is applied in direct contact to the underside/interior of the structural roof deck.
3. Sufficient insulation is installed to maintain the monthly average temperature of the condensing surface above 45°F (7°C). The condensing surface is defined as either the structural roof deck or the interior surface of an air-impermeable insulation applied in direct contact with the underside/interior of the structural roof deck.

In addition to meeting these requirements, the fire code requirements must also be met; this may limit the use of some insulating materials for this application.

In general, to insulate the roof deck, some type of spray-on insulation or combination of insulations is used. When insulating the roof deck, the attic gables must also be insulated to complete the conditioned envelope and must provide an air barrier to meet the thermal bypass requirements for walls. An insulated roof deck allows the HVAC duct system to be brought into the conditioned space as well as allowing the attic to be used for storage, etc.

It is possible to use rigid foam insulation above the roof deck sheathing to raise the condensing surface temperature above the requirement in the code; however, in most of Climate Zone 4, that would require an insulation level of an R-10. Typical rigid foams would require a 2 inch layer to be applied and then protected with another layer of sheathing to attach the roof covering material.

VENT SELECTION

If ventilating the roof, locate vents high along the roof ridge and low along the eave or soffit (see Figure 5-12). Vents should provide air movement across the entire roof area. There are wide varieties of products available including ridge, gable, soffit, mushroom, and turbine vents.

The combination of continuous ridge vents along the peak of the roof and continuous soffit vents at the eave provides the most effective ventilation. Ridge vents come in a variety of colors to match any roof. Some brands are made of corrugated plastic that can be covered by cap shingles to hide the vent.

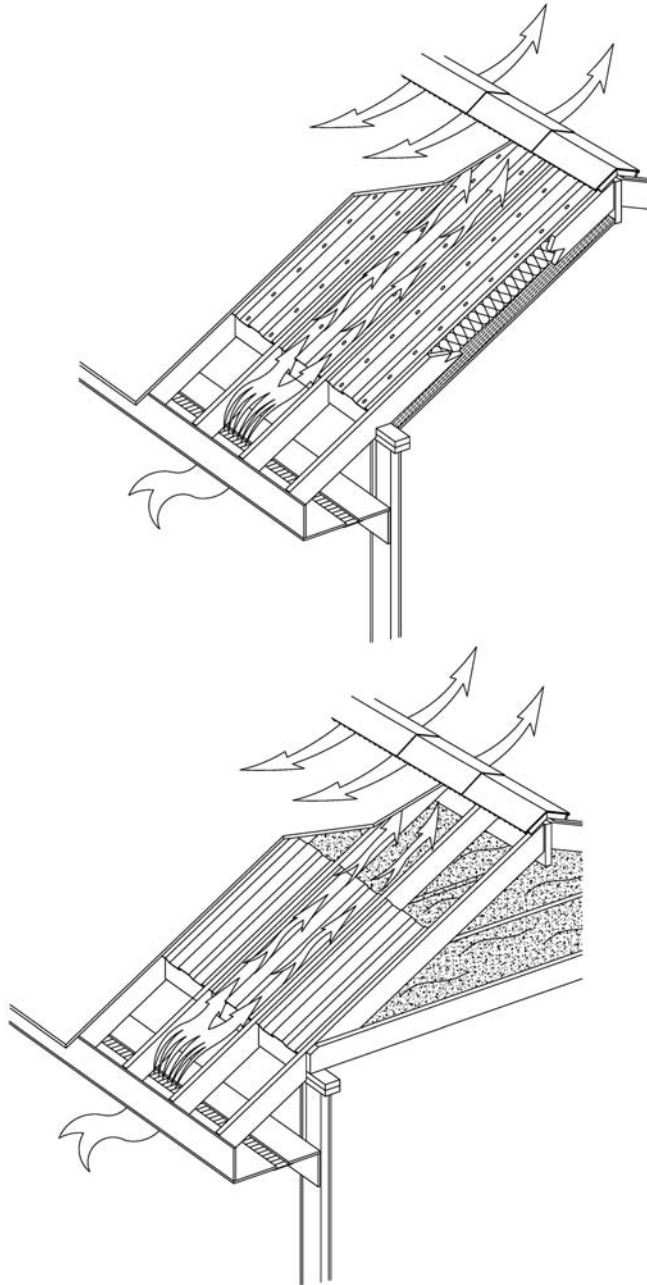

Figure 5 - 12 Ridge and Soffit Vents

GUIDELINES FOR ATTIC/ROOF VENTILATION

The amount of attic ventilation needed is determined by the size of the attic floor and the amount of moisture entering the attic. General guidelines are:

- Provide 1 square foot of attic vent for each 150 square feet of attic floor area.
- The total vent area should be divided equally between high and low vents; thus, if 5 total square feet of vent are needed, locate 2.5 square feet at the ridge and another 2.5 square feet at the soffit.
- Attic vent areas should be the net free area, or about 70% of the total vent area.

POWERED ATTIC VENTILATOR PROBLEMS

Electrically powered roof ventilators can consume more electricity to operate than they save on air conditioning costs; they are not recommended for most designs, see Figure 5-13. Power vents can create negative pressures in the home that may have detrimental effects, such as:

- Drawing air from the crawl space into the home;
- Removing conditioned air from the home through ceiling leaks and bypasses;
- Pulling pollutants, such as radon and sewer gases, into the home; and
- Backdrafting fireplaces and fuel-burning appliances.

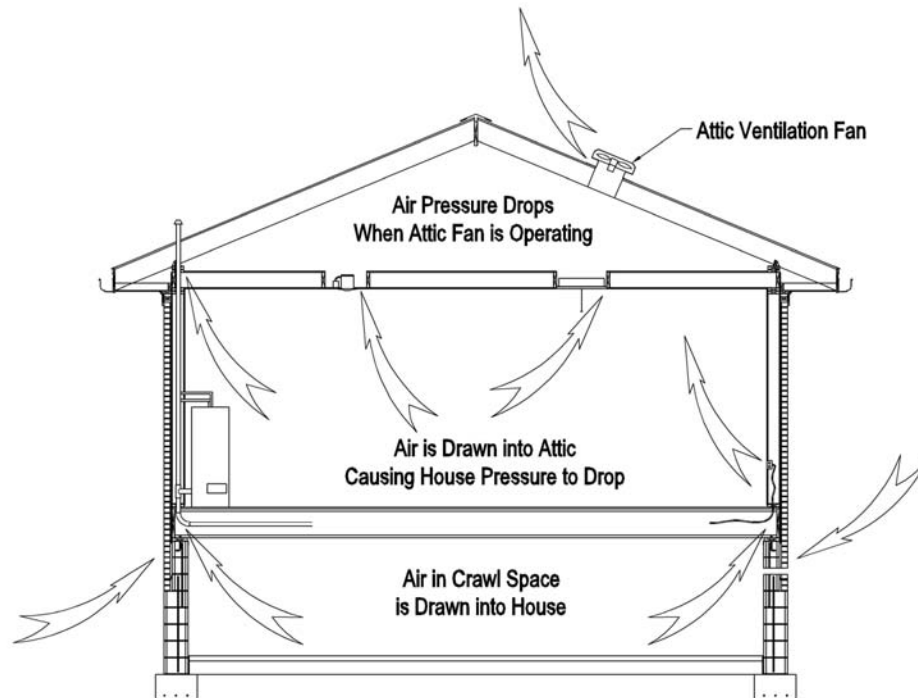

Figure 5 - 13 Pressure Problems Due to Powered Attic Ventilators

ATTIC FLOOR INSULATION TECHNIQUES

Loose-fill and batt insulation can both be installed on an attic floor. Guidelines for ensuring a quality loose-fill attic insulation installation are:

- Seal attic air leaks, as prescribed by fire and energy codes.
- Follow manufacturers' clearance requirements for heat-producing equipment found in an attic, such as flues or exhaust fans. Local building codes may mandate other blocking requirements. Use metal flashing, plastic or cardboard baffles, or pieces of batt insulation for blocking. Table 5-10 summarizes attic blocking requirements.
- Use cardboard baffles, insulation batts, or other baffle materials to preserve ventilation from soffit vents at eave of roof.
- Insulate the attic hatch or attic stair with batts or foam insulation attached to the attic hatch or placed under the steps of the pull-down stairs. For added protection, use the foam boxes sold for insulating over a pull-down attic stairway.
- Avoid fluffing the insulation (blowing with too much air) by using the proper air-to-insulation mixture in the blowing machine. A few insulation contractors have "fluffed" (added extra air to) loose-fill insulation to give the impression of a high R-value. The insulation may be the proper depth, but if too few bags are installed, the R-values will be less than claimed.
- Obtain complete coverage of the blown insulation at similar insulation depths. Staple attic rulers throughout the attic to ensure uniform depth of insulation.

Table 5-10 Attic Blocking Requirements Summary

Object	Recommended Action*
Recessed light	Use airtight, insulated cover (IC) models
Doorbell transformer	Install on rafters or other roof framing to avoid insulation
Masonry chimney	As specified by local fire codes, typically 2 inch clearance
Metal chimney	Follow manufacturer's recommendations, typically 2 inch clearance
Flues from fuel-burning equipment	Follow manufacturer's recommendations
Kitchen/bath exhaust	Duct to the outside
Heat/light/ventilation	Follow manufacturer's recommendations, typically 3 inch clearance
Uncovered electric boxes	Cover the box with rated metal plate; caulk around box, if necessary, and insulate
Whole house fan	Install blocking up to the fan housing; leave 3 inch clearance around fan motor
Attic access door	Block around the door if blowing in loose-fill insulation; weatherstrip and insulate door or hatch

*These are general guidelines. Follow specific manufacturer's recommendations.

Guidelines for ensuring a quality batt, attic insulation installation:

- Seal attic air leaks, as prescribed by fire and energy codes.
- Block around heat-producing devices. Insulate the attic hatch or attic stair. When installing the batts, make certain they completely fill the joist cavities, Figure 5-14. Shake batts to ensure proper loft. If the joist spacing is uneven, patch gaps in the insulation with scrap pieces. Try not to compress the insulation with wiring, plumbing or ductwork. In general, obtain complete coverage of full-thickness, non-compressed insulation.
- If two layers of batts are used, install top layer perpendicular to joists.

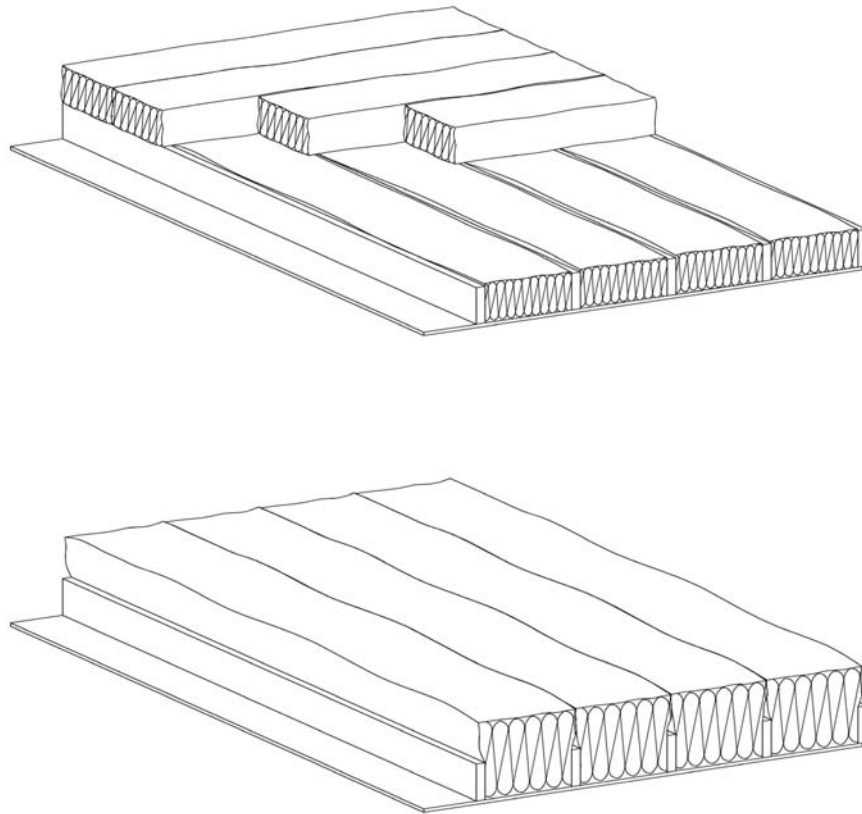
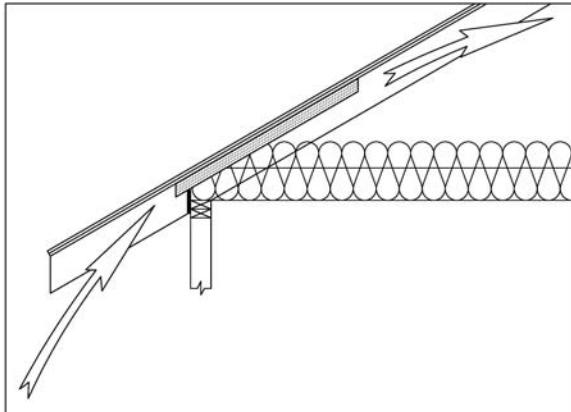

Figure 5 - 14 Full Width Batts in Ceiling

INCREASING THE ROOF HEIGHT AT THE EAVE

One problem area in many standard roof designs is at the eave. There is often insufficient space for full insulation without blocking air flow from the soffit vents. If the insulation is compressed, its R-value will decline. Figure 5-15 shows several solutions to this problem. If using a truss roof, purchase raised heel trusses that form horizontal over-hangs. They should provide clearance for both ventilation and insulation. In stick-built roofs, where rafters and ceiling joists are cut and installed on the construction site, an additional top plate, which lays across the top of the ceiling joists at the eave, will prevent compression of the attic insulation. The rafters sitting on this raised top plate allow for both insulation and ventilation.

WOOD - FRAMED ROOF



Normal Roof System Compresses Insulation and Lowers R - Value

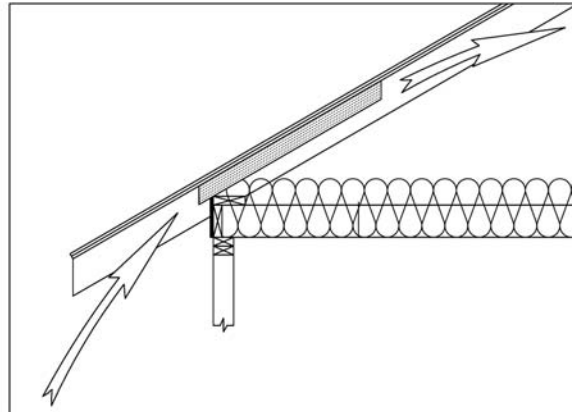

Roof System with Raised Top Plates Allows Proper Insulation R - Value

TRUSS ROOF

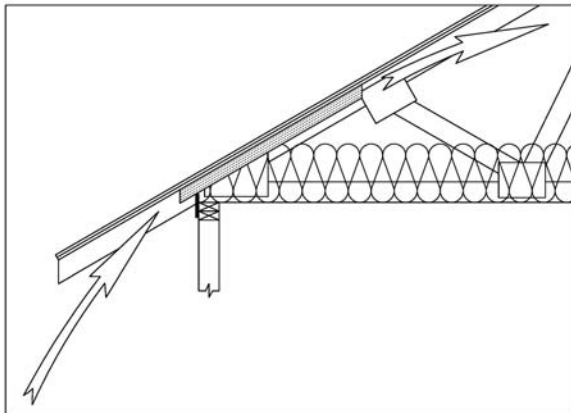

Normal Truss System Compresses Insulation and Lowers R - Value

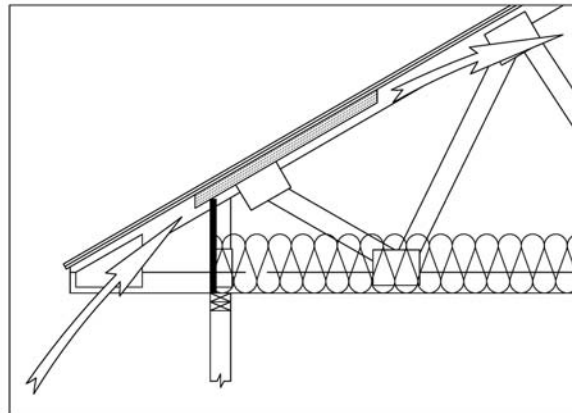

Truss System with Raised Heel Allows Proper Insulation R - Value

Figure 5 - 15 Insulation Options for Eaves

The raised top plate design also minimizes wind washing of the attic insulation. Wind washing occurs where air entering the soffit vents flows through the attic insulation. When installing a raised top plate, most framing crews also place a band joist over the open joist cavities of the roof framing. The band joists help prevent wind washing, which can reduce attic insulation R-values on extremely cold days and can add moisture to the insulation.

Raised top plates also elevate the overhang of the home, which may enhance the building's attractiveness. The aesthetic advantage is especially useful in one-story homes with standard 8-foot ceilings.

PROBLEMS WITH RECESSED LIGHTS

Standard recessed fixtures require a clearance of several inches between the sides of the lamp's housing and the attic insulation. In addition, insulation cannot be placed over the fixture. Even worse, recessed lights create air leaks between the attic and the home. IC-rated fixtures have a heat sensor switch, which allows the fixture to be covered with insulation. However, these units also leak air.

Airtight, IC-rated fixtures are now required by the 2006 IRC. Alternatives to recessed lights include surface-mounted ceiling fixtures and track lighting, which typically contribute less air leakage to the home.

CATHEDRAL CEILING INSULATION TECHNIQUES

Cathedral ceilings are a special case because of the limited space for insulation and ventilation within the depth of the rafter. Fitting in a 10-inch batt (R-30) and still providing ventilation is impossible with a 2x6 or 2x8 rafter.

The 2006 IRC allows R-30 cathedral ceiling insulation for Climatic Zone 4.

BUILDING R-30 CATHEDRAL CEILINGS

Cathedral ceilings, built with 2x12 rafters, can be insulated with standard R-30 batts and still have plenty of space for ventilation. Some builders use a vent baffle between the insulation and roof decking to ensure that the ventilation channel is maintained.

If 2x12s are not required structurally, most builders find it cheaper to construct cathedral ceilings with 2x10 rafters and high-density R-30 batts, which are 8¼ inches thick. Some contractors wish to avoid the higher cost of 2x10 lumber and use 2x8 rafters.

If framing with 2x6 and 2x8 rafters, insufficient space is available for standard R-30 insulation. Higher insulating values can be obtained by installing rigid foam insulation under the rafters. However, foam is expensive and using thicker rafters with batt or loose-fill insulation may be substantially less costly. A fire-rated material must cover the rigid foam insulation when used on the interior of the building. Five-eighths inch drywall should meet the requirement; check with local fire codes or building inspectors for confirmation.

SCISSOR TRUSSES

Scissor trusses are another cathedral ceiling efficiency framing option. Scissor trusses have a greater roof pitch than ceiling pitch, thus creating more space than standard framing provides between the roof and the ceiling. Make certain scissor trusses provide adequate room for both R-30 insulation and ventilation, especially at their ends, which form the eave section of the roof.

CEILINGS WITH EXPOSED RAFTERS

A cathedral ceiling with exposed rafters or roof decking is difficult and expensive to insulate well. Often, foam insulation panels are used over the attic deck as shown in Figure 5-16. However, to achieve R-30, 4 to 7 inches of foam insulation, costing \$1 to \$3 per square foot, are needed.

In homes where exposed rafters are desired, it may be more economical to build a standard, energy efficient cathedral ceiling and then add exposed decorative beams underneath. Note that homes having tongue-and-groove ceilings can experience substantially more air leakage than solid, drywall ceilings. Install a continuous air barrier, sealed to the walls, above the tongue-and-groove roof deck.

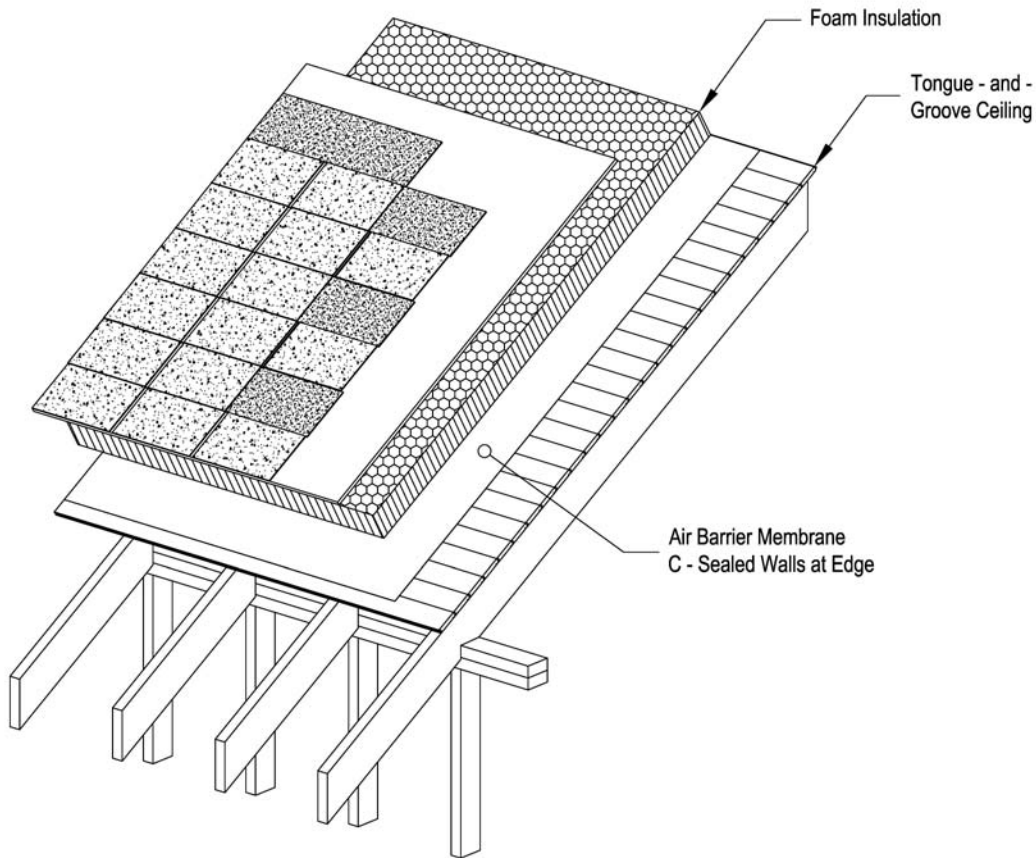

Figure 5 - 16 Foam Insulation on Roof Deck

RADIANT HEAT BARRIERS

Radiant heat barriers (RHB) are reflective materials that can reduce summer heat gain in attics and walls (Figure 5-17). While not generally a substitute for insulation, they can be used in concert with minimum levels of insulation to lower air conditioning costs during warm and hot weather.

Radiant heat barriers have a controversial history in the Southeastern United States because manufacturers oversold their benefits during the late 1980s and early 1990s. In particular, some sales representatives made excessive claims about the performance of the product and priced it too high to provide a reasonable payback.

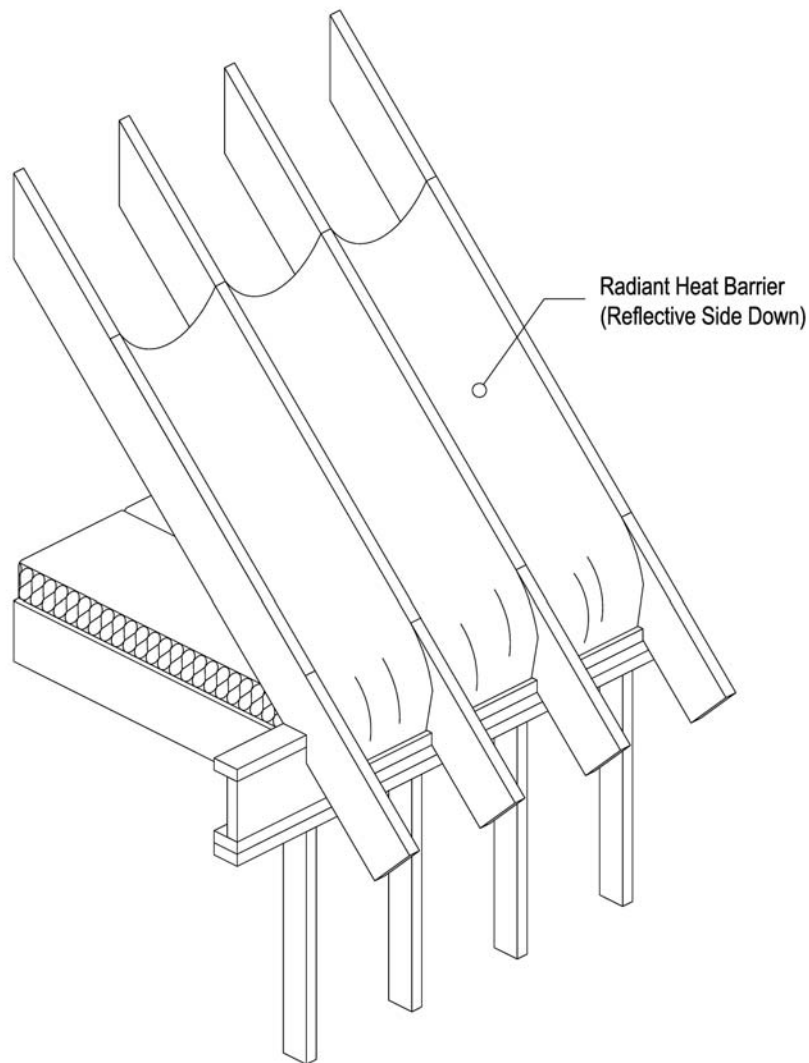

Figure 5 - 17 Radiant Heat Barrier



CHAPTER 6: WINDOWS AND DOORS

Windows and doors connect the interior of a house to the outdoors, provide ventilation and daylight, and are important aesthetic elements. Windows and doors are often the architectural focal point of residential designs, yet they provide the lowest insulating value in the building envelope. Although the efficiency of windows has improved markedly, they still represent one of the major energy liabilities in new construction.

The type, size, and location of windows greatly affect heating and cooling costs. Select good quality windows, but shop wisely for the best combination of price and performance. Many house building budgets have been blown by spending thousands of additional dollars on premium windows with marginal energy savings. In general, double-paned units with low-emissivity coatings are a cost effective window choice. Well-designed homes carefully consider window location and size. In summer, unshaded windows can double the costs of keeping a house cool. Year round, poorly designed windows can cause glare, fade fabrics, and reduce comfort. Chapter 11, on passive solar design, describes how to design windows to save even more energy.

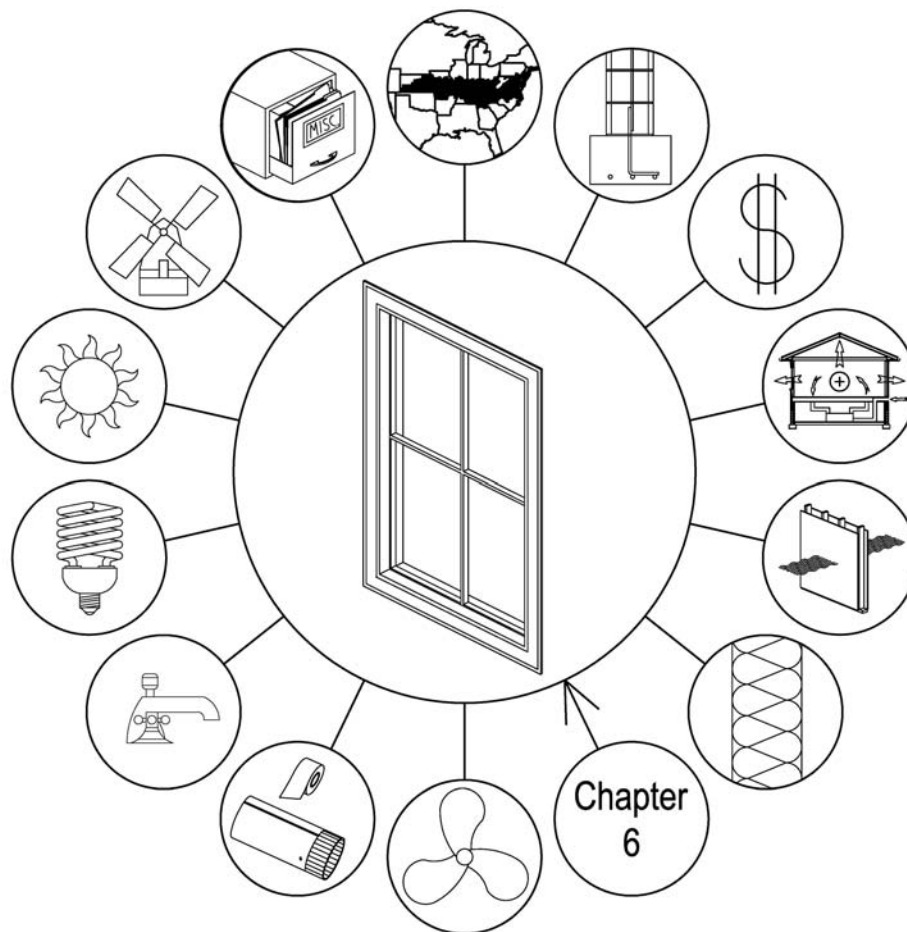



WINDOWS

Windows lose and gain heat in the following ways:

- Conduction through the glass and frame;
- Convection across the air space in double- and triple-glazed units;
- Air leakage around the sashes and the frame; and
- Radiation through the glazing.

The goals of energy efficient windows are:

- Low U-factors;
- Moderate to high transmission rates of visible light;
- Low air leakage rates; and
- Low transmission rates of invisible radiation—ultraviolet and infrared light energy.

Few windows can meet all of these goals, but in the past several years, the window industry has unveiled an exciting array of higher efficiency products. The most notable developments include:

- Thermal breaks to reduce heat losses through highly conductive glazing systems and metal frames;
- Inert gas fills, such as argon and krypton, which help deaden the air space between layers of glazing and thus increase the insulating values of the windows;
- Tighter weatherstripping systems to lower air leakage rates; and
- Low-emissivity coatings, which hinder radiant heat flow.

LOW-EMISSIVITY COATINGS

Low-emissivity (low-e) coatings are primarily designed to hinder radiant heat flow through multi-glazed windows. Some surfaces, like flat black metal, used on wood stoves, have high-emissivities and radiate heat readily. However, other surfaces, such as shiny aluminum, have low-emissivities, and radiate little heat, even at elevated temperatures.

Low-e coatings are usually composed of an extremely thin layer of silver applied between two protective layers. The use of coatings is now the standard for national window manufacturers. Low-e windows (see Figures 6-1 and 6-2) also:

- Screen ultraviolet radiation, which reduces fabric fading; and
- Increase the surface temperature of the inside of the surface glass, which makes us feel warmer because we radiate less heat.

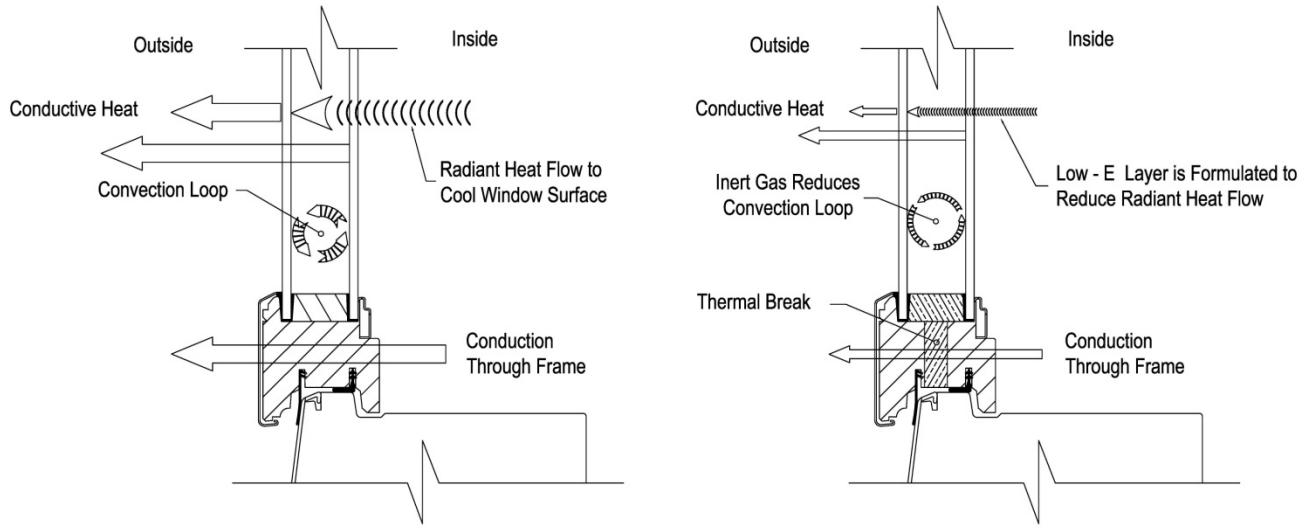

Figure 6 - 1 Winter Heat Loss in a Double-Glazed Window

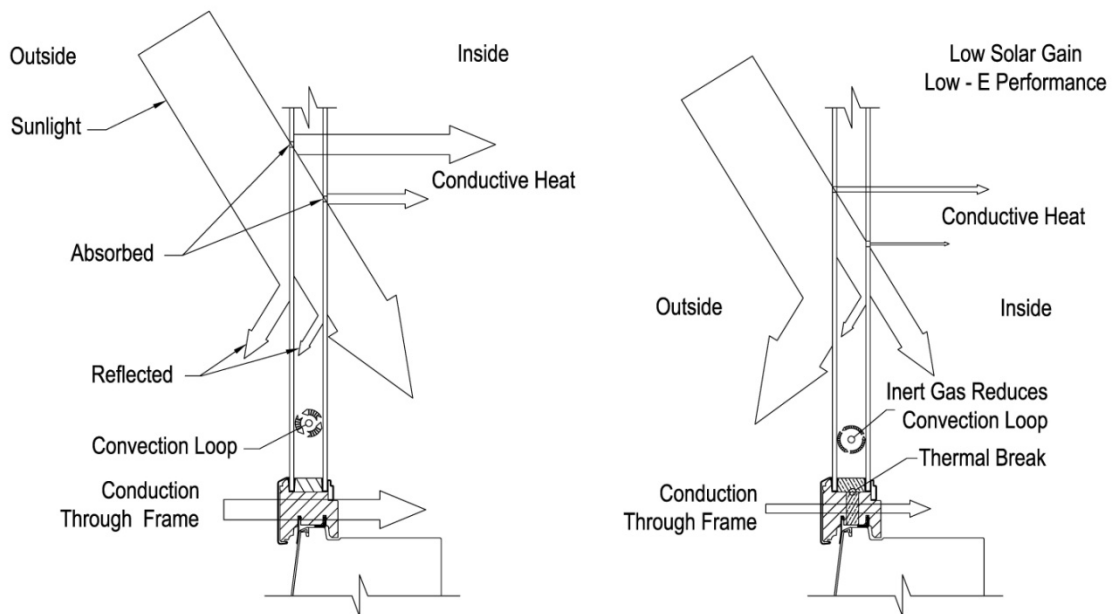

Figure 6 - 2 Summer Heat Gain in a Double-Glazed Window



INERT GAS FILLS

Inert gas fills enhance the performance of double pane windows by reducing conductive heat loss. The inert gas is heavier than air and circulates less, thereby reducing the convection currents between the window panes. Inert gas is also a better insulator than air. ENERGY STAR® rated windows, which can be used in any climate zone, are filled with an inert gas.

SOLAR HEAT GAIN COEFFICIENT

In climate zones of the country where cooling is the major energy use, it is important that the windows reduce the solar heat gain. The Solar Heat Gain Coefficient (SHGC) is the fraction of incident solar radiation admitted through a window. SHGC is expressed as a number between 0 and 1. The lower a window's solar heat gain coefficient, the less solar heat it transmits. All climate zones of the country benefit from reduced solar heat gain on the east and west facing windows because the *heat gain* for heating reduces the heating energy requirement *less than* the cooling energy requirement. There is a tradeoff between solar heat gain and visible light transmission (an optical property that indicates the amount of visible light transmitted). There is also a tradeoff between the solar heat gain coefficient and the amount of passive solar heating of the house. The overall energy benefits favor windows with a lower solar heat gain coefficient for houses in Climate Zone 4.

The more layers of glass, coatings, or tints that a window has, the more sunlight it impedes and hence, the lower the SHGC. Typical values are shown in Table 6-1.

Table 6-1 Typical Window Treatment Solar Heat Gain Coefficients

Treatment	Window Type	Solar Heat Gain Coefficient*
Double-paned window	1/8-inch glass	0.76
	1/4-inch glass	0.70
	Tinted 1/4-inch glass	0.58
Low-e window	Typical range, clear glass	0.34 to 0.40
	High solar gain	0.55 to 0.60
	Low solar gain	0.25
Venetian blinds	1/4-inch double glass	0.46
White roller blinds	1/4-inch double glass	0.22
Light, airy drapes	1/4-inch double glass	0.50
Heavy drapes	1/4-inch double glass	0.36
Shade screen, louvered sun screen	1/4-inch double glass	0.36

*Fraction of sunlight that passes through the glass and window treatment. Assumes that sunlight strikes perpendicular to glass.



Homes with low-e windows usually already have low SHGC. Most low-e windows have SHGC values less than 0.40. If SHGC values higher than 0.40 are desirable for certain windows, some low-e models have SHGC over 0.50. The most common application for high-SHGC windows would be on the southern exposure of passive solar homes, as described in Chapter 11.

MULTIPLE PANES

To further reduce the U-factor of windows, some manufacturers have introduced triple pane windows. The middle pane will typically be some type of clear plastic rather than glass to reduce weight. These windows have an additional space that enhances the window's U-factor. Careful consideration of these windows must be done for use in Climate Zone 4.

WINDOW RECOMMENDATIONS FOR CLIMATE ZONE 4

U-Factor

U-factor is the rate at which a window, door, or skylight conducts non-solar heat flow. It is usually expressed in units of Btu/hr-ft²-°F. U-factor ratings represent the entire window performance, including frame and spacer material. A lower U-factor means that the windows, doors, or skylights are more energy efficient, Figure 6-3.

Recommendation: The code minimum for windows is a U-factor of 0.40. High performance homes should have a window U-factor of 0.35 or less.

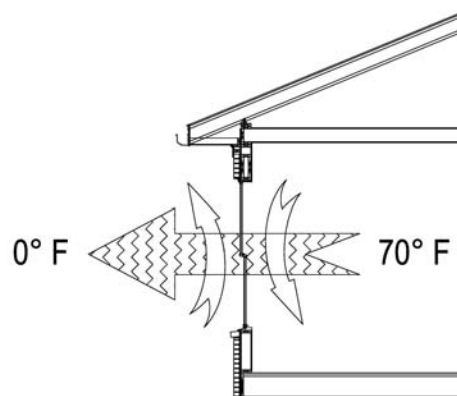

Figure 6 – 3 U-factor

Solar Heat Gain Coefficient (SHGC)

The SHGC is the fraction of solar radiation admitted through a window, door, or skylight—either transmitted directly and/or absorbed, and subsequently released as heat inside a home. The lower the SHGC, the less solar heat it transmits and the greater its shading ability. A product with a high SHGC rating is more effective at collecting solar heat gain during the winter. A product with a low SHGC rating is more effective at reducing cooling loads during the summer by blocking heat gained from the sun (see Figure 6-4).

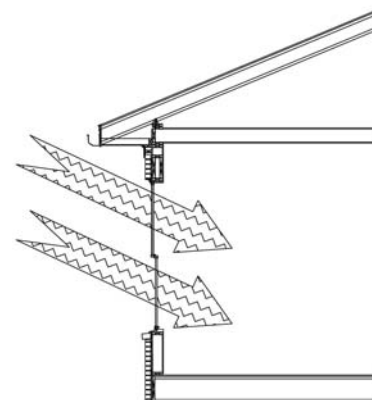

Figure 6 – 4 Solar Heat Gain



Recommendation: There is no code requirement for SHGC for Climate Zone 4; however, high performance homes should consider SHGC values of 0.40 or less. While windows with lower SHGC values reduce summer cooling and overheating, they also reduce winter solar heat gain.

Visible Transmittance (VT)

Visible transmittance (VT) is a fraction of the visible spectrum of sunlight (380 to 720 nanometers), weighted by the sensitivity of the human eye, that is transmitted through a window's, door's or skylight's glass. A product with a higher VT transmits more visible light. The VT you need for a window, door, or skylight should be determined by your home's daylighting requirements and/or whether you need to reduce interior glare in a space (Figure 6-5).

Recommendation: A window with VT glass above 0.70 (for the glass only) is desirable to maximize daylight and view. This translates into a VT window above 0.50 (for the total window including a wood or vinyl frame).

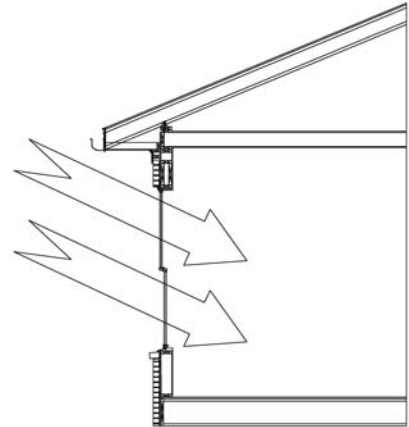

Figure 6 – 5 Daylight

Air Leakage (AL)

Air leakage is the rate of air infiltration around a window, door, or skylight in the presence of a specific pressure difference across it. It is expressed in units of cubic feet per minute per square foot of frame area (cfm/ft²). A product with a low air leakage rating is tighter than one with a high air leakage rating (see Figure 6-6). While many think that AL is extremely important, it is not as important as U-factor and SHGC for common high performance windows.

Recommendation: The code requires an AL of 0.30 or below (cfm per square foot).

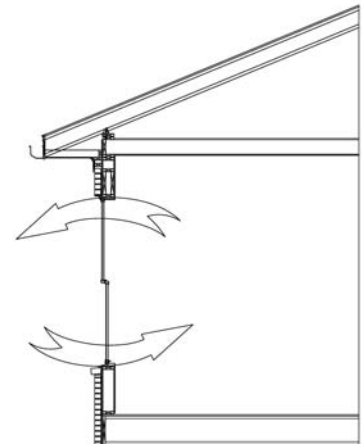

Figure 6 – 6 Infiltration



THE PROBLEM OF REPORTING WINDOW INSULATING VALUES

Window insulating values are typically reported in U-factors. This is a weighted average that includes the frame materials. Single-glazed windows generally have U-factors of 1.0. Double-glazed products have U-factors of about 0.50. Double-glazed, low-emissivity windows have U-factors of 0.40 or less.

The National Fenestration Rating Council (NFRC) offers a voluntary testing program for window and door products. The NFRC reports average whole window U-factors. Windows listed by the NFRC include a label showing test data and other information.

Occasionally, window U-factor is reported as the efficiency of the center of the glass alone. However, windows are made of more than just glass (Figure 6-7). They have a frame or sash, spacer strips, typically made of aluminum which hold the sections of glass in a double-glazed window apart, and a jamb. The claimed U-factor should reflect the overall insulating value of all of the components. New procedures coordinated by the NFRC encourage window manufacturers to report window U-factors consistently and accurately.

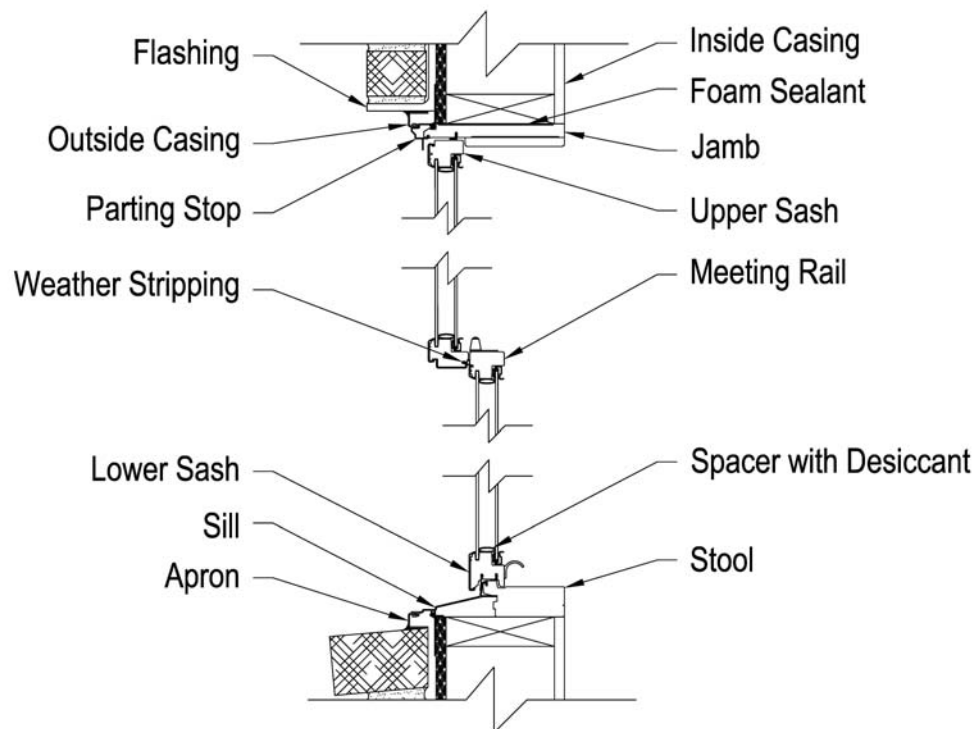

Figure 6 – 7 Window Anatomy

NFRC labels (Figure 6-8) provide:

- U-Factor—conductive heat loss of the assembly
- Solar Heat Gain Coefficient (SHGC)—the fraction of sunlight transmitted through the window;
- Visible Transmittance (VT)—the fraction of visible light that is transmitted; and
- Air Leakage (AL)—expressed as cfm per square foot.

 National Fenestration Rating Council® CERTIFIED		World's Best Window Co. Millennium 2000+ Vinyl-Clad Wood Frame Double Glazing • Argon Fill • Low E Product Type: Vertical Slider	
ENERGY PERFORMANCE RATINGS			
U-Factor (U.S./I-P)		Solar Heat Gain Coefficient	
0.35		0.32	
ADDITIONAL PERFORMANCE RATINGS			
Visible Transmittance		Air Leakage (U.S./I-P)	
0.51		0.2	
Condensation Resistance		—	
51			
<small>Manufacturer stipulates that these ratings conform to applicable NFRC procedures for determining whole product performance. NFRC ratings are determined for a fixed set of environmental conditions and a specific product size. NFRC does not recommend any product and does not warrant the suitability of any product for any specific use. Consult manufacturer's literature for other product performance information. www.nfrc.org</small>			

Figure 6-8 NFRC Label*

When shopping for windows, find out the total U-factor, not just that for the glass. The best approach is to use the NFRC label as the objective source of information. The NFRC website lists the values of products that are NFRC certified.

*Image courtesy of NFRC



BENEFITS OF ENERGY STAR® RATED WINDOWS

National window manufacturers have begun to market windows that can be used in any Climate Zone. As a result, these windows have a U-factor of 0.35 or less in order to meet the requirements of climate zones with predominately heating loads and a solar heat gain coefficient of 0.40 or less to meet the requirements of climate zones with predominately cooling loads. These characteristics are achieved with a combination of low-e coating, inert gas fill, and coatings to reduce solar heat gain.

Table 6-2 shows the economic benefits of different types of windows compared to the minimum window requirement for Climate Zone 4, U-factor = 0.48. Some of the additional investment in higher performance windows can be offset by the reduced size of the heating and cooling system required for the home.

Type of Window	Energy Savings* (\$/yr) {Code minimum U – 0.48}	Break-even Investment‡ (\$)
U – 0.40, SHGC– 0.50	18	204
U – 0.35, SHGC– 0.40	52	591

*Savings are for a two-story home with 254 sq ft of windows and 2 exterior doors, located in Lexington, KY, with approximately 17 - 3x5 windows.
 ‡See Chapter 2 for information on break-even investment.

In addition to the economic benefit, high performance windows also improve the comfort of a home by increasing the inside surface temperature of the glass, Figure 6-9. The increased surface temperature lowers the radiant heat loss from the skin, making the room with the high performance windows feel more comfortable.

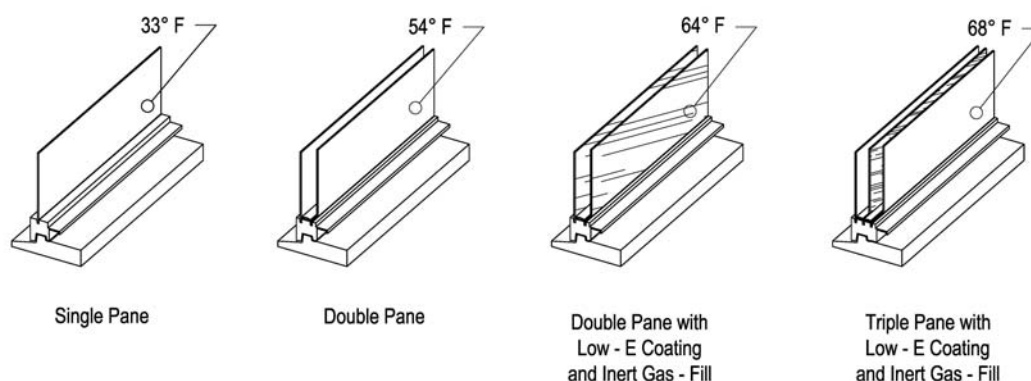

Figure 6-9 Inside Window Surface Temperatures in Cold Weather (75°F Inside and 20°F Outside)



PROPER WINDOW INSTALLATION

Step 1: Make sure that the window fits in rough opening and that the sill is level.

Step 2: Install window level and plumb according to the manufacturer's instructions.

Step 3: Use non-expanding foam sealant to seal between the jamb and the rough opening, or stuff the gap with a backer rod or insulation and cover the insulation with caulk. Remember that most fibrous insulation does not stop air leaks—it just serves as a filter.

Step 4: If using a housewrap air barrier, slide the top window flashing under the barrier and seal the barrier to the window jamb with long-life window flashing tape or other appropriate, durable sealant.

Step 5: After interior and exterior trim is installed, seal the gap between the trim and the interior or exterior finish with long-life caulk.

FUTURE WINDOW OPTIONS

ELECTROCHROMIC WINDOWS

A new genre of windows is composed of special materials that have coatings, which can darken the glazing by running electricity through the unit. Some manufacturers already have prototypes of these high technology windows in operation. At night and on sunny, summer days, an electric switch can be turned on to render the windows virtually opaque.

SOLID WINDOWS

Another new window technology uses gel-type material (aerogel), up to one inch thick, between layers of glazing. The window offers increased insulating value, but at present, this feature is not completely transparent and is extremely expensive.

WINDOWS AND NATURAL VENTILATION

A primary purpose of windows is to provide ventilation. With Kentucky's mild climate, natural ventilation can maintain comfort for much of the spring and fall. In the mountains, natural ventilation can provide sufficient cooling for summer as well. The size and placement of the window openings affect ventilation. Casement windows open fully for ventilation, while only half of the entire area of double-hung and slider windows can open. Casement windows can also help channel breezes into the home. The optimum placement of windows for ventilation would be on each side of the house to take advantage of breezes from any direction. However, the ventilation benefits of east and west windows are overshadowed by the problems they pose by allowing summer sunlight into the home. In general, it is best to avoid east and west windows. Place the major glass areas on the south and a moderate number of windows on the north for cross ventilation.

Each room should have a window to allow air to enter (ideally located on the south or north wall) and a separate opening to enable air to exit. The outlet may be a doorway leading into another area of the home. The inlet and outlet should be located so that they create breezes in the areas most frequently occupied.



In addition to providing for cross ventilation, windows can be used to create ventilation between low and high areas. For example, in a two-story house, as air inside warms, it rises and exits through upper level windows. As the air rises, it draws outside air into the house, through the lower windows. This process is known as the stack effect. However, the force of the rising air is weak, so it is not practical to provide special design features in a house to encourage this type of ventilation. In fact, natural ventilation of any type is unpredictable. While having some operable windows is desirable, it is not usually worthwhile to increase construction costs solely to increase the window area for ventilation.

WINDOWS AND SHADING

In some cases, windows in Kentucky require additional shading; options include:

- Overhangs
- Exterior shades and shutters
- Interior shades and shutters
- Landscaping and trees

The effectiveness of different window shading options depends on the composition of the incoming sunlight. Sunlight reaches the home in three forms: direct, diffuse, and ground reflected. On a clear day, most sunlight is direct, traveling as a beam without obstruction from the sun to a home's windows. In winter, most of the direct sunlight striking a window is transmitted through the glass; however, in summer, the sun strikes south windows at a much steeper angle, and much of the direct sunlight is reflected. The majority of the sunlight entering south-facing windows in the summer is either diffuse—bounced between the particles in the sky until it arrives as a bright haze—or is reflected off the ground.

In developing a strategy for effectively shading windows, all three forms of sunlight must be considered. Overhangs, long thought to be very effective for shading south-facing windows, are best at blocking direct sunlight and are therefore only a partial solution.

OVERHANGS

Overhangs shade direct sunlight on windows facing within 30 degrees of south. Overhangs on east and west windows are ineffective unless they are as long as the window is high. Overhangs above south-facing windows should provide complete shade for the glazing in midsummer—around July 21—yet still allow access to winter sunlight (see Table 6-3). For a standard 8-foot wall with windows, the overhang should be 2 feet in length. Make certain that there is a gap between the bottom of the overhang and the top of the glazing to prevent shading the upper portion of the glass in winter. Figure 6-10 illustrates a method for sizing overhangs above south-facing windows. Retractable awnings allow full winter sunlight, yet provide effective summer shading. Retractable awnings should have open sides or vents to prevent accumulation of hot air underneath. Awnings may be more expensive than other shading options, but they serve as an attractive design feature.



Table 6-3 Summer and Winter Sun Angles			
		Degrees from Horizon at Noon	
	Latitude (Degrees)	July 21	January 21
Covington/Newport	39	68	28
Lexington/Louisville	38	69	29
Madisonville, KY	37	70	30
KY/TN border	36	71	31

GUIDELINES FOR OVERHANGS

Size south overhangs using the diagram and these rules:

1. Draw to scale the wall to be shaded by the overhang.
2. Draw the summer sun angle upward from the bottom of the glazing.
3. Draw the overhang until it intersects the summer sun angle line.
4. Draw the line at the winter sun angle from the bottom edge of the overhang to the wall.
5. Use a solid wall above the line where winter sun hits. The portion of the wall below that line should be glazed.

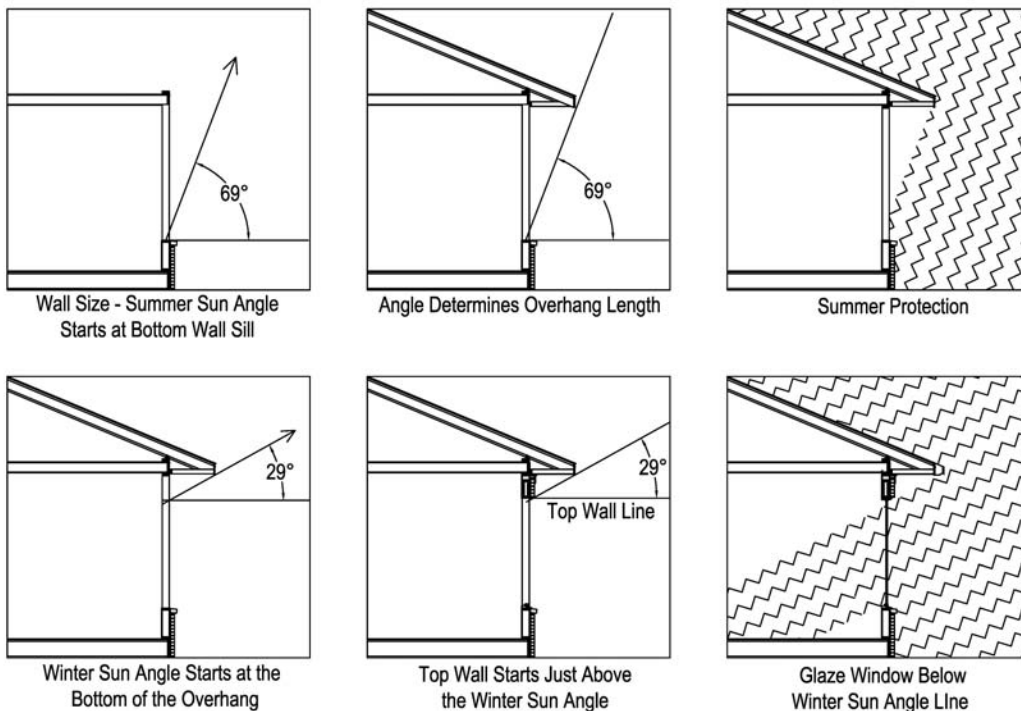

Figure 6 – 10 Size Southern Overhang for Summer and Winter (Lexington, KY latitude)

EXTERIOR SHADES AND SHUTTERS

Exterior window shading treatments are effective cooling measures because they block both direct and indirect sunlight before it enters windows. Solar shade screens have a thick weave that blocks up to 70% of all incoming sunlight before it enters the windows. The screens absorb sunlight so they should be used on the outside of the windows. From the outside, they look slightly darker than regular screening, and provide greater privacy. From the inside, many people do not detect a difference. They also serve as insect screening and come in several colors. The screens should be removed in winter to allow full sunlight through the windows. Thin, louvered metal screens are a more expensive alternative to the fiberglass product.

INTERIOR SHADES AND SHUTTERS

Shutters and shades located inside the house include curtains, roll-down shades, and Venetian blinds. More sophisticated devices are also available, such as shutters that slide over the windows on a track and interior movable insulation.

Interior shutters and shades are generally the least effective shading measures because they try to block sunlight that has already entered the room. However, if east-, south-, or west-facing windows do not have exterior shading, interior measures are needed. The most effective interior treatments are solid shades with a reflective surface facing outside. In fact, simple white roller blinds keep the house cooler than more expensive louvered blinds. Louvered blinds do not provide a solid surface and allow trapped heat to migrate between the blinds into the house.

LANDSCAPING AND TREES

Kentucky's abundant trees are wonderful for natural shading, but they must be located appropriately to provide shade in summer and not block the winter sun coming from the south. Even deciduous trees that lose their leaves during cold weather block some winter sunlight—a few bare trees can block over 50 percent of the available solar energy. Some guidelines for energy efficient landscaping are given in Chapter 1, Figure 1-1.

DOORS

Exterior wood doors have low insulating values, typically R-2.2. Storm doors increase the R-value only to about R-3.0 and are not good energy investments. The best energy-conserving alternative is a metal or fiberglass insulated door. Metal doors have a foam insulation core, which can increase the insulating value to above R-5. They usually cost no more than conventional exterior doors and come in decorative styles, complete with raised panels and insulated window panes. Insulated metal or fiberglass doors usually have excellent weatherstripping and long lifetimes. They will not warp; they offer increased security. As with windows, it is important to seal the rough openings. Thresholds should seal tightly against the bottom of the door and must be caulked underneath. After the door is installed, check it carefully, when closed, to see if there are any air leaks.



ACCESSIBLE DESIGN

Almost one out of ten people will suffer from physical disabilities during their lifetime. Designing homes to ensure accessibility for the physically impaired adds little to the cost of a home. One important feature is to ensure that both exterior and interior door openings are 3'-0" wide to allow passage of a wheelchair or walker. Ensuring that baths and kitchens have adequate room for wheelchairs is another feature that adds little to construction costs but is expensive to retrofit.

CHAPTER 7: HEATING, VENTILATION, AIR CONDITIONING (HVAC)

When thinking about energy efficiency, one of the most important decisions to be made regarding a new home is the type of heating and cooling system to install. Equally critical to consider is the selection of the heating and cooling contractor. The operating efficiency of a system depends as much on proper installation as it does on the performance rating of the equipment.

Improper design and improper installation of the HVAC system have negative impacts on personal comfort and on energy bills. Improper design and installation of a HVAC system can dramatically degrade the quality of air in a home. Poorly designed and poorly installed ducts can create dangerous conditions that may reduce comfort, degrade indoor air quality, or even threaten the health of the homeowners.

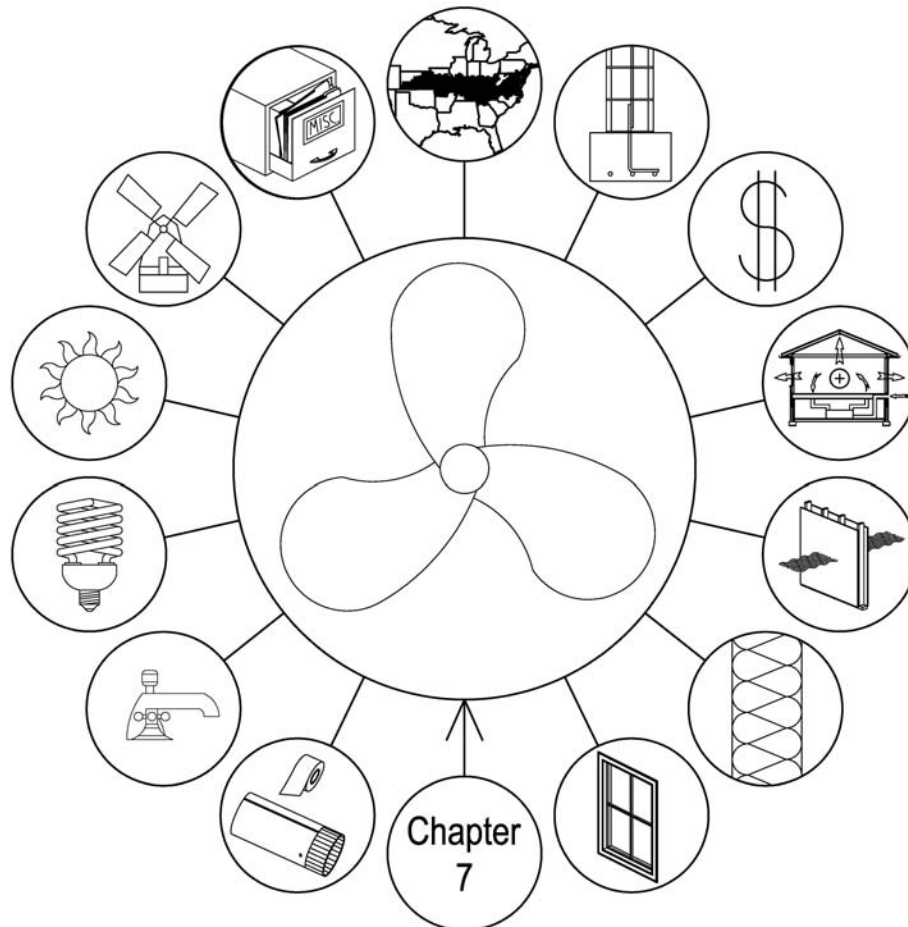



TYPES OF HEATING SYSTEMS

Keys to obtaining design efficiency of a system in the field include:

- Sizing the system for the specific heating and cooling load of the home being built;
- Proper selection and proper installation of controls;
- Correctly charging the unit with the proper amount of refrigerant;
- Sizing and designing the layout of the ductwork or piping for maximizing energy efficiency; and
- Insulating and sealing all ductwork.

Two types of heating systems are most common in a new home: forced-air or radiant, with forced-air being used in the majority of the homes. The heat source is either a furnace, which burns a gas, or an electric heat pump. Furnaces are generally installed with central air conditioners. Heat pumps provide both heating and cooling. Some heating systems have an integrated water heating system.

FORCED-AIR SYSTEM COMPONENTS

Most new homes have forced-air heating and cooling systems. These systems use a central furnace plus an air conditioner, or a heat pump. Figure 7-1 shows all the components of a forced-air system. In a typical system, several of these components are combined into one unit. Forced-air systems utilize a series of ducts to distribute the conditioned heated or cooled air throughout the home. A blower, located in a unit called an air handler, forces the conditioned air through the ducts. In many residential systems, the blower is integral with the furnace enclosure.

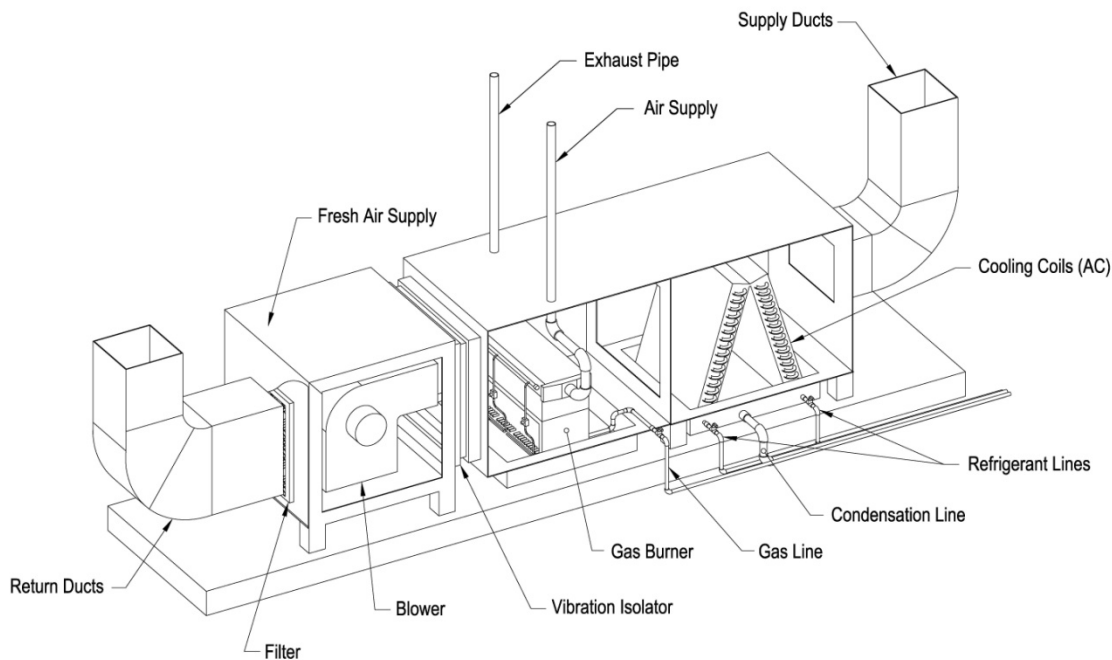

Figure 7 – 1 Components of Horizontal Flow Forced-Air Systems



Most homes in Kentucky have a choice of the following approaches for central, forced-air systems; fuel-fired furnaces with electric air conditioning units, electric heat pumps or a dual fuel system that combines both a fuel-fired furnace with an electric heat pump. The best system for each home depends on the cost and efficiency of the equipment, annual energy use, and the local price and availability of energy sources. In most homes, either type of system, if designed and installed properly, will economically deliver personal comfort.

RADIANT HEATING SYSTEMS

Radiant heating systems typically combine a central boiler, water heater or heat pump water heater with piping, to transport steam or hot water into the living area. Heating is delivered to the rooms in the home via radiators or radiant floor systems, such as radiant slabs or underfloor piping.

Advantages of radiant heating systems include:

- Quieter operation than heating systems that use forced-air blowers.
- Increased personal comfort at lower air temperatures. The higher radiant temperatures of the radiators or floors allow people to feel warmer at lower air temperatures. Some homeowners, with radiant heating systems, report being comfortable at room air temperatures of 60°F.
- Better zoning of heat delivered to each room.
- Increased comfort from the heat. Many homeowners, with radiant heating systems, find that the heating is more comfortable.

Disadvantages of radiant heating systems include:

- Higher installation costs. Radiant systems typically cost 40% to 60% more to install than comparable forced-air heating systems.
- No provision for cooling the home. The cost of a radiant heating system, combined with central cooling, would be difficult to justify economically. Some designers of two-story homes have specified radiant heating systems on the bottom floor and forced-air heating and cooling on the second floor.
- No filtering of the air. Since the air is not cycled between the system and the house, there is no filtering of the air.
- Difficulty in locating parts. A choice of dealers may be limited.

HEAT PUMP EQUIPMENT

Heat pumps are designed to move heat from one fluid to another. The fluid inside the home is air and the fluid outside is either air (air-source), or water (geothermal). In the summer, heat from the inside air is moved to the outside fluid. In the winter, heat is taken from the outside fluid and moved to the inside air.

AIR-SOURCE HEAT PUMPS

The most common type of heat pump is the air-source heat pump. Most heat pumps operate at least twice as efficiently as conventional electric resistance heating systems in Climate Zone 4. They have typical lifetimes of 15 years, compared to 20 years for most furnaces.



Heat pumps use the vapor compression cycle to move heat (see Figure 7-2). A reversing valve allows the heat pump to work automatically in either heating or cooling mode. The heating process is:

1. The compressor (in the outside unit) pressurizes the refrigerant, which is piped inside.
2. The hot gas enters the inside condensing coil. Room air passes over the coil and is heated. The refrigerant cools and condenses.
3. The refrigerant, now a pressurized liquid, flows outside to a throttling valve where it expands to become a cool, low pressure liquid.
4. The outdoor evaporator coil, which serves as the condenser in the cooling process, uses outside air to boil the cold, liquid refrigerant into a gas. This step completes the cycle.
5. If the outdoor air is so cold that the heat pump cannot adequately heat the home, electric resistance strip heaters usually provide supplemental heating.

Periodically in winter, the heat pump must switch to a "defrost cycle," which melts any ice that has formed on the outdoor coil. Packaged systems and room units use the above components in a single box.

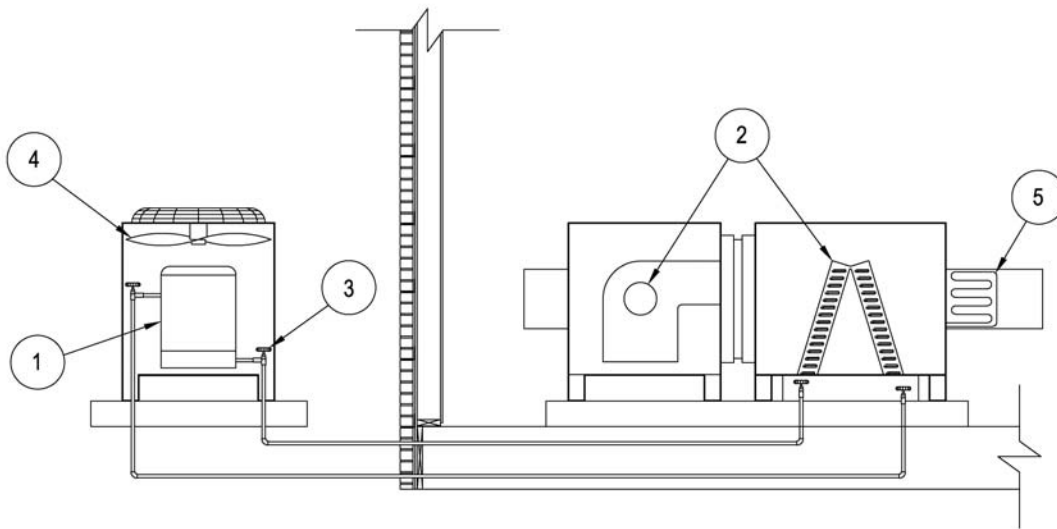

Figure 7 - 2 Air Conditioner Vapor Compression Cycle

At outside temperatures of 25°F to 35°F, a properly sized heat pump can no longer meet the entire heating load of the home. The temperature at which a properly sized heat pump can no longer meet the heating load is called the balance point. To provide supplemental backup heat, many builders use electric resistance coils called strip heaters. The strip heaters, located in the air-handling unit, are much more

expensive to operate than the heat pump itself. The strip heaters should not be oversized, as they can drive up the peak load requirements of the local electric utility.

A staged, heat pump thermostat can be used in concert with multistage strip heaters to minimize strip heat operation. To overcome this problem, some houses use a dual-fuel system that heats the home with natural gas or propane when temperatures drop below the balance point.

Air-source heat pumps should have outdoor thermostats, which prevent operation of the strip heaters at temperatures above 35°F or 40°F. Many mechanical and energy codes require controls to prevent strip heater operation during weather when the heat pump alone can provide adequate heating.

The proper airflow across the coil is essential for the efficient operation of a heat pump. During installation, the airflow rate must be checked to ensure that it meets the manufacturer's recommendations.

AIR-SOURCE HEAT PUMP EFFICIENCY

The heating efficiency of a heat pump is measured by its Heating Season Performance Factor (HSPF), which is the ratio of heat provided in Btu per hour to watts of energy used. This factor considers the losses when the equipment starts up and stops, as well as the energy lost during the defrost cycle.

New heat pumps manufactured after 2005 are required to have an HSPF of at least 7.7. Typical values for the HSPF are 7.7 for minimum efficiency, 8.0 for medium efficiency, and 8.2 for high efficiency. Variable speed heat pumps have HSPF ratings as high as 9.0, and geothermal heat pumps have HSPFs over 10.0. The HSPF averages the performance of heating equipment for a typical winter in the United States, so the actual efficiency will vary in different climates.

To modify the HSPF for a specific climate, a modeling study was conducted and an equation was developed that modifies the HSPF, based on the local design winter temperature. In colder climates, the HSPF declines and in warmer climates, it increases. In Climate Zone 4, the predicted HSPF is approximately 15% less than the reported HSPF.

GEOHERMAL HEAT PUMPS

Unlike an air-source heat pump, which has an outside air heat exchanger, a geothermal heat pump relies on fluid-filled pipes, buried beneath the earth, as a source of heating in winter and cooling in summer, Figures 7-3, 7-4. In each season, the temperature of the earth is closer to the desired temperature of the home, so less energy is needed to maintain comfort. Eliminating the outside equipment means higher efficiency, less maintenance, greater equipment life, no noise, and no inconvenience of having to mow around that outdoor unit. This is offset by the higher installation cost.

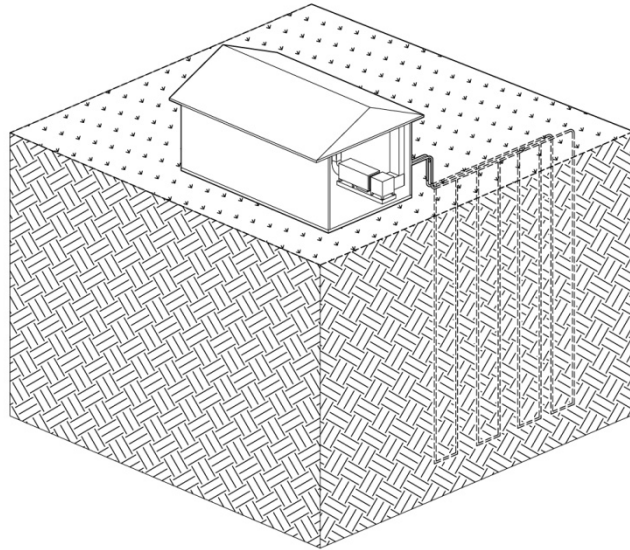

Figure 7 – 3 Deep Well Loop

Geothermal Heat Pumps

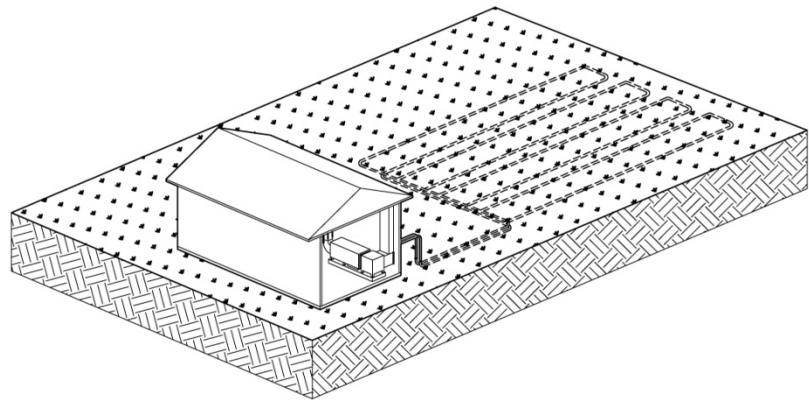

Figure 7 – 4 Shallow Trench Loop

There are several types of closed loop designs for piping:

- In deep well systems, a piping loop extends several hundred feet underground.
- Shallow loops are placed in long trenches, typically about 6 feet deep and several hundred feet long. Coiling the piping into a "slinky" reduces the length requirements.
- For homes located on large private lakes, loops can be installed at the bottom of the lake, which usually decreases the installation costs and may improve performance.

Proper installation of the geothermal loops is essential for high performance and the longevity of the system. Choose only qualified professionals, who have several years experience installing geothermal heat pumps similar to that designed for your home.

Geothermal heat pumps provide longer service than air-source units do. The inside equipment should last as long as any other traditional heating or cooling system. The buried piping usually has a 25-year warranty. Most experts believe that the piping will last even longer because it is made of a durable plastic with heat-sealed connections, and the circulating fluid has an anticorrosive additive.

Geothermal heat pumps cost \$1,300 to \$2,300 more per ton than conventional air-source heat pumps. The actual cost varies according to the difficulty of installing the ground loops as well as the size and features

of the equipment. Because of their high installation cost, these units may not be economical for homes with low heating and cooling needs. However, their lower operating costs, reduced maintenance requirements, and greater comfort may make them attractive to many homeowners.

GEOHERMAL HEAT PUMP EFFICIENCY

The heating efficiency of a geothermal heat pump is measured by the Coefficient of Performance (COP), which measures the number of units of heating or cooling produced by a unit of electricity. The COP is a more direct measure of efficiency than the HSPF and is used for geothermal heat pumps because the water temperature is more constant. Manufacturers of geothermal units provide COPs for different supply water temperatures. If a unit were installed with a COP of 3.0, the system would be operating at about 300% efficiency.

FURNACE EQUIPMENT

Furnaces burn fuels such as natural gas, propane, and fuel oil to produce heat and provide warm, comfortable indoor air during cold weather. Furnaces come in a variety of efficiencies. The comparative economics between heat pumps and furnaces depend on the type of fuel burned, its price, the home's design, and the outdoor climate. Recent energy price increases have improved the economics of more efficient equipment. However, due to the long-term price uncertainty of different forms of energy, it is difficult to compare furnaces with various fuel types and heat pumps.

FURNACE OPERATION

Furnaces require oxygen for combustion and extra air to vent exhaust gases. Most furnaces are non-direct vent units—they use the surrounding air for combustion. Others, known as direct vent or uncoupled furnaces, bring combustion air into the burner area via sealed inlets that extend to outside air.

Direct vent furnaces can be installed within the conditioned area of a home since they do not rely on inside air for safe operation. Non-direct vent furnaces must receive adequate outside air for combustion and exhaust venting. The primary concern with non-direct vent units is that a malfunctioning heater may allow flue gases, which could contain poisonous carbon monoxide, into the area around the furnace. If there are leaks in the return system, or air leaks between the furnace area and living space, carbon monoxide could enter habitable areas and cause severe health problems.

Most new furnaces have forced draft exhaust systems, meaning a blower propels exhaust gases out the flue to the outdoors. Atmospheric furnaces, which have no forced draft fan, are not as common due to federal efficiency requirements. However, some furnace manufacturers have been able to meet the efficiency requirements with atmospheric units. Atmospheric furnaces should be isolated from the conditioned space. Those units located in well ventilated crawl spaces and attics usually have plenty of combustion air and encounter no problem venting exhaust gases to the outside.

However, units located in closets or mechanical rooms inside the home, or in relatively tight crawl spaces and basements, may have problems. Furnace mechanical rooms must be well sealed from the other rooms of the home (see Figure 7-5). The walls, both interior and exterior, should be insulated. Two outside-air ducts sized for the specific furnace should be installed from outside into the room, one opening near the floor and another near the ceiling, or as otherwise specified in your locality's gas code.

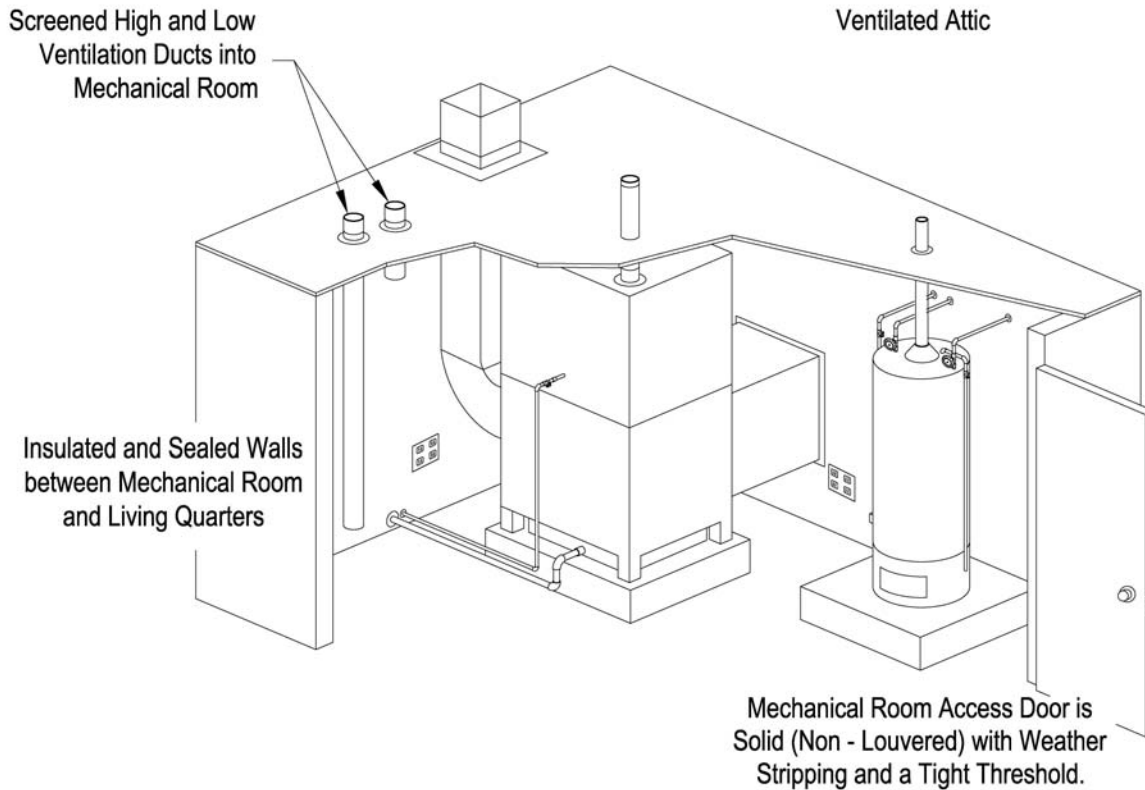

Figure 7 - 5 Sealed Mechanical Room Design

MEASURES OF EFFICIENCY FOR FURNACES

The efficiency of a gas furnace is measured by the Annual Fuel Utilization Efficiency (AFUE), a rating that takes into consideration losses from pilot lights, start-up, and stopping. The minimum AFUE for most furnaces is now 78%, with efficiencies ranging up to 97% for furnaces with condensing heat exchangers. The AFUE does not consider the unit's electricity use for fans and blowers, which can easily exceed \$50 annually. An AFUE rating of 78% means that for every \$1.00 worth of fuel used by the unit, approximately \$.78 worth of usable heat is produced. The remaining \$.22 worth of energy is lost as waste heat and exhaust up the flue. Efficiency is highest if the furnace operates for longer periods. Oversized units run intermittently and have reduced operating efficiencies.

Furnaces with AFUEs of 78% to 87% include components such as electronic ignitions, efficient heat exchangers, better intake air controls, and induced draft blowers to exhaust combustion products. Models with efficiencies over 90%, commonly called condensing furnaces, include special secondary heat exchangers that actually cool flue gases until they partially condense, so that heat losses up the exhaust pipe are virtually eliminated.



A drain line must be connected to the flue to catch condensate. One advantage of the cooler exhaust gas is that the flue can be made of plastic pipe rather than metal and can be vented horizontally through a side wall.

There are a variety of condensing furnaces available. Some rely primarily on the secondary heat exchanger to increase efficiency, while others, such as the pulse furnace, have revamped the entire combustion process.

A pulse furnace achieves efficiencies over 90% using a spark plug to explode gases, sending a shock wave out an exhaust tailpipe. The wave creates suction to draw in more gas through one-way flapper valves, and the process repeats. Once such a furnace warms up, the spark plug is not needed because the heat of combustion will ignite the next batch of gas. The biggest problem is noise, so make sure the furnace is supplied with a good muffler, and do not install the exhaust pipe where any noise will be annoying.

Because of the wide variety of condensing furnaces on the market, compare prices, warranties, and service. Also, compare the economics carefully with those of moderate efficiency units. Condensing units may have longer paybacks than expected for energy efficient homes due to reduced heating loads. Table 7-1 compares the break-even investment for high efficiency gas furnaces in Code and in ENERGY STAR® homes.

Type of Treatment AFUE 0.95	Energy Savings*(\$/yr) Compared to AFUE 0.80	Break-even Investment‡ (\$)
Code Home	42	477
ENERGY STAR® Home	31	352

*For a system in Lexington, KY
‡See Chapter 2 for information on break-even investment.

ELECTRIC INTEGRATED SYSTEMS

Several products use central heat pumps for water heating, space heating, and air conditioning. These integrated units are available in both air-source and geothermal models. To be a viable choice, integrated systems should:

- Have a proven track record in the field;
- Cost about the same, if not less, than comparable separate heating and hot water systems;
- Provide at least a five-year warranty; and
- Be properly sized for both the heating and hot water load.



Make sure the unit is not substantially more expensive than a separate energy efficient heat pump and electric water heater. Units within \$1,500 may provide favorable economic returns.

UNVENTED FUEL-FIRED HEATERS

Unvented heaters that burn natural gas, propane, kerosene, or other fuels are not recommended. While these devices usually operate without problems, the consequences of a malfunction are life threatening—they can exhaust carbon monoxide directly into household air. Unvented heaters also can cause serious moisture problems inside the home.

Most devices come equipped with alarms designed to detect air quality problems. However, many experts question putting a family at any risk of carbon monoxide poisoning; they see no rationale for bringing these units into a home (Figure 7-6).

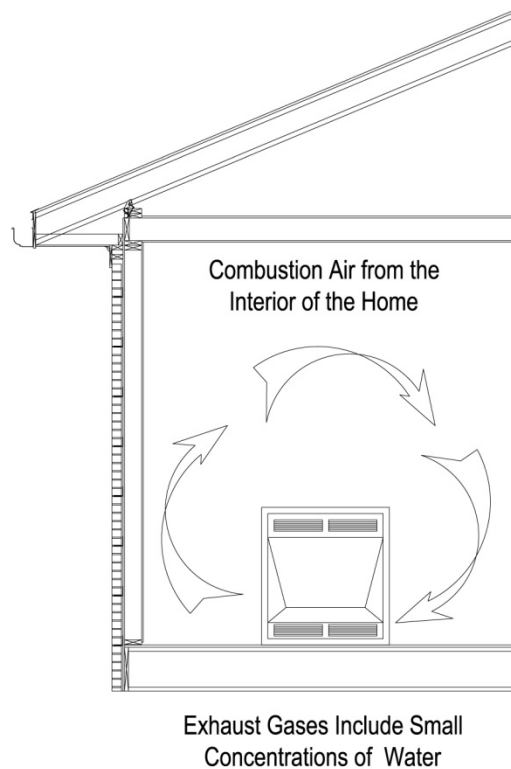

Figure 7-6 Unvented Heater

Examples of unvented units to avoid include:

- Vent-free gas fireplaces. Use sealed combustion, direct vent units instead.
- Room space heaters.

Choose forced draft, direct-vent models instead (Figure 7-7).

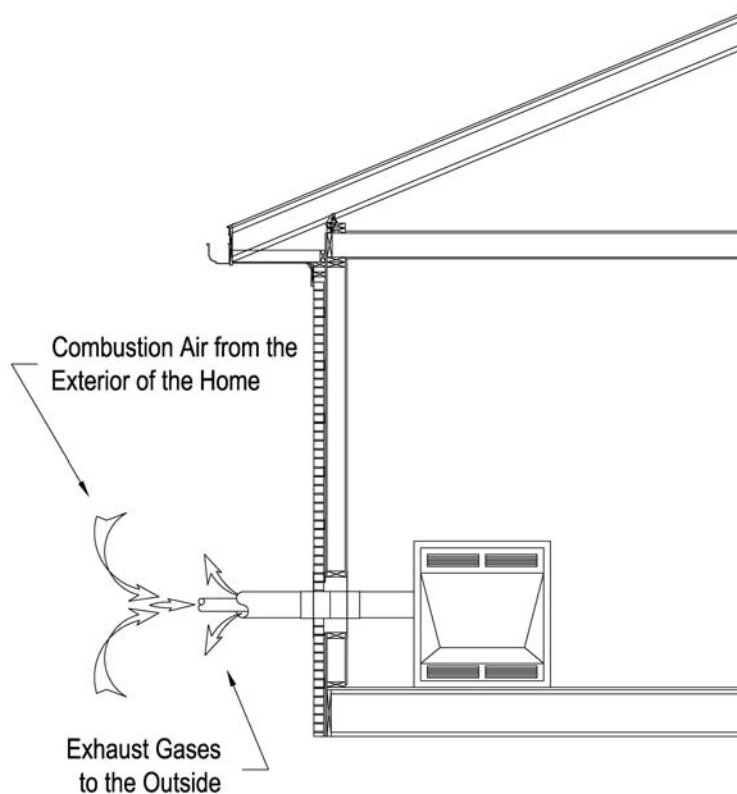

Figure 7-7 Direct Vent Heater

AIR CONDITIONING

In summer, air conditioners and heat pumps work the same way to provide cooling and dehumidification. They extract heat from inside the home and transfer it outside. Both systems typically use a vapor compression cycle. This cycle circulates a refrigerant, a material that increases in temperature significantly when compressed and cools rapidly when expanded. The exterior portion of a typical air conditioner is called the condensing unit and houses the compressor, the noisy part that uses most of the energy, and the condensing coil.

An air-cooled condensing unit should be kept free from plants and debris that might block the flow of air through the coil or damage the thin fins of the coil. Ideally, the condensing unit should be located in the shade. However, do not block air flow to this unit with dense vegetation, fencing or overhead decking.

The inside mechanical equipment, called the air-handling unit, houses the evaporator coil, the indoor blower, and the expansion, or throttling valve. The controls and ductwork for circulating cooled air to the house complete the system.



AIR CONDITIONERS

Air conditioners use the vapor compression cycle, a 4-step process (see Figure 7-8).

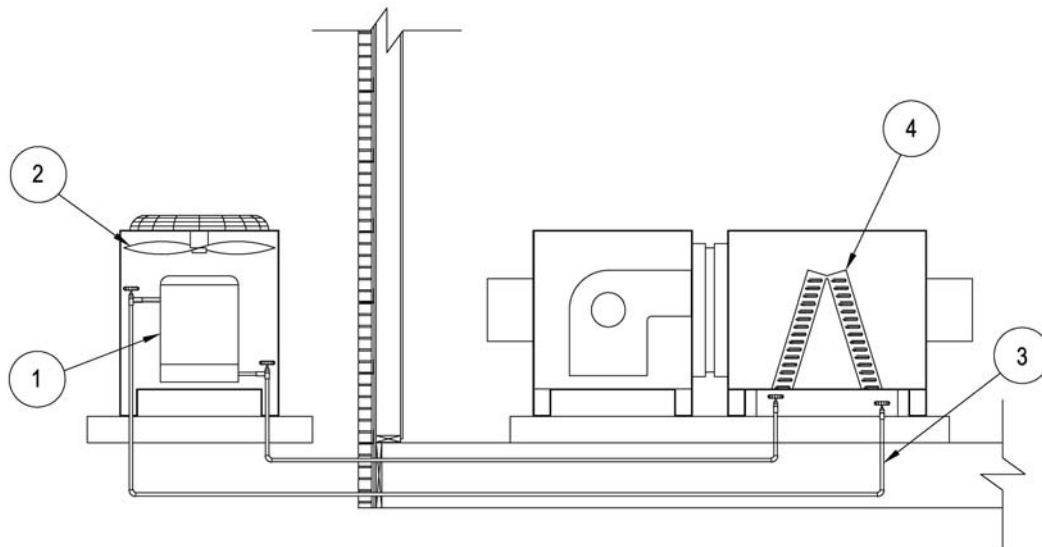

Figure 7-8 Air Conditioner Vapor Compression Cycle

1. The compressor (in the outside unit) pressurizes a gaseous refrigerant. The refrigerant heats up during this process.
2. Fans in the outdoor unit blow air across the heated, pressurized gas in the condensing coil; the refrigerant gas cools and condenses into a liquid.
3. The pressurized liquid is piped inside to the air-handling unit. It enters a throttling or expansion valve, where it expands and cools.
4. The cold liquid circulates through evaporator coils. Inside air is blown across the coils and cooled while the refrigerant warms and evaporates. The cooled air is blown through the ductwork. The refrigerant, now a gas, returns to the outdoor unit where the process repeats.

If units are not providing sufficient dehumidification, the typical homeowner's response is to lower the thermostat setting. Since every degree the thermostat is lowered increases cooling bills 3% to 7%, systems that have nominally high efficiencies, but inadequate dehumidification, may suffer from higher than expected cooling bills. In fact, poorly functioning "high" efficiency systems may actually cost more to operate than a well-designed, moderate efficiency unit.



Make certain that the contractor has used Manual J techniques to size the system so that the air conditioning system meets both sensible and latent (humidity) loads at the manufacturer's claimed efficiency.

THE SEER RATING

The cooling efficiency of a heat pump or an air conditioner is rated by the Seasonal Energy Efficiency Ratio (SEER), a ratio of the average amount of cooling provided during the cooling season to the amount of electricity used. Current national legislation mandates a minimum SEER 13.0 for most residential air conditioners. Efficiencies of some units can exceed SEER 19.0.

Similar to the HSPF, a modeling study was conducted and an equation was developed that modifies the SEER, based on the local design summer temperature. In warmer climates, the SEER declines. In Climate Zone 4, the predicted SEER is approximately 5% less than the reported SEER.

VARIABLE SPEED UNITS

The current minimum standard for air conditioners is SEER 13. Higher efficiency air conditioners may be quite economical. Table 7-2 examines the economics of different options for a sample home. In order to increase the overall operating efficiency of an air conditioner or heat pump, multispeed and variable speed compressors have been developed. These compressor units can operate at low or medium speeds when the outdoor temperatures are not extreme. They can achieve a SEER of 15 to 17. The cost of variable speed units is generally about 30% higher than standard units. Variable speed units offer several advantages over standard, single-speed blowers, such as:

- They usually save energy;
- They are quieter, and because they operate fairly continuously, start-up noise is far less (often the most noticeable sound); and
- They dehumidify better. Some units offer a special dehumidification cycle, which is triggered by a humidistat that senses when the humidity levels in the home are too high.

Table 7-2 Air Conditioner Economics

Type of Treatment	Energy Savings* (\$/yr)	Break-even Investment‡ (\$)
SEER 14 (3 tons) - compared to SEER 13	20	227
SEER 15 (3 tons) - compared to SEER 14	32	363

*For a system in Lexington, KY
 ‡See Chapter 2 for information on break-even investment.



PROPER INSTALLATION

Too often, high efficiency cooling and heating equipment is improperly installed, which can cause it to operate at a substantially reduced efficiency. A SEER 13 air conditioning system that is installed poorly with leaky ductwork may operate at 25% to 40% lower efficiency during hot weather. Typical installation problems are:

- Improper charging of the system—the refrigerant of the cooling system is the workhorse—it flows back and forth between the inside coil and the outside coil, changing states, and undergoing compression and expansion. A system can have too little or too much refrigerant. The HVAC contractor should use the manufacturer’s installation procedures to charge the system properly. The correct charge cannot be ensured by pressure gauge measurements alone. In new construction, the refrigerant should be weighed in. Then, use either the supercharge temperature method or, for certain types of expansion valves, the subcooling method, to confirm that the charge is correct.
- Reduced air flow—if the system has poorly designed ductwork, constrictions in the air distribution system, clogged or more restrictive filters, or other impediments, the blower may not be able to transport adequate air over the indoor coils of the cooling system. Reduced air flow of 20% can drop the operating efficiency of the unit by about 1.7 SEER points; thus, a unit with a SEER 13.0 would only operate at SEER 11.3.
- Inadequate air flow to the outdoor unit—if the outdoor unit is located under a deck or within an enclosure, adequate air circulation between the unit and outdoor air may not occur. In such cases, the temperature of the air around the unit rises, thereby making it more difficult for the unit to cool the refrigerant that it is circulating. The efficiency of a unit surrounded by outdoor air that is 10 degrees warmer than the ambient outside temperature can be reduced by over 10%.

HVAC SYSTEMS

For proper operation, a HVAC system must be properly designed, sized and installed. A proper HVAC system will provide an improved indoor environment and minimize the cost of operation. In the planning process for an energy efficient home, everything should be done to reduce the heating and cooling load on the home before the HVAC system is designed.

SIZING

When considering a HVAC system for a residence, remember that energy efficient and passive solar homes have less demand for heating and cooling. Substantial savings may be obtained by installing smaller units that are properly sized to meet the load. Because energy bills in more efficient homes are lower, higher efficiency systems will not provide as much annual savings on energy bills and may not be as cost effective as in less efficient homes.

Not only does oversized equipment cost more, but also it can waste energy. Oversized equipment may also decrease comfort. For example, an oversized air conditioner cools a house but may not provide adequate dehumidification. This cool, but clammy air creates an uncomfortable environment.



***Do not rely on rule of thumb methods
to size HVAC equipment.***

Many contractors select air conditioning systems based on a rule, such as 600 square feet of cooled area per ton of air conditioning (a ton provides 12,000 Btu per hour of cooling). Instead, use a sizing procedure such as:

- Calculations in Manual J published by the Air Conditioning Contractors Association;
- Similar procedures developed by the American Society of Heating, Refrigeration, and Air Conditioning Engineers (ASHRAE); or
- Software procedures developed by electric or gas utilities, the U.S. Department of Energy or HVAC equipment manufacturers.

The heating and cooling load calculations rely on the outside *winter and summer design temperatures* (see the appendix for a definition) and the size and type of construction for each component of the building envelope, as well as the heat given off by the lights, people, and equipment inside the house. If a zoned heating and cooling system is used, the loads in each zone should be calculated. Table 7-3 compares the size of heating and cooling systems for the homes in Table 2-2. The more efficient home reduces the heating load 35% and the cooling load 26%. Thus, the \$600 to \$1,000 savings from reducing the size of the HVAC equipment offset the additional cost of the energy features in the more efficient home.

Table 7-3 Equipment Sizing Comparison			
Type of House	Code Home HERS=98	ENERGY STAR® Home HERS=85	Exceeds ENERGY STAR® Home HERS=70
<i>HVAC System Sizing</i>			
Heating (BTU/hour)	52,200	38,800	25,700
Cooling (BTU/hour)	31,700	25,700	19,800
Estimated tons of cooling*	3.0	2.5	2.0
Square feet/ton	667	800	1,000
*Estimated at 110% of calculated size. There are 12,000 Btu/hour in a ton of cooling.			

Oversimplified rules-of-thumb would have provided an oversized heating and cooling system for the more efficient home. The typical rule-of-thumb in Kentucky has been to allow for 600 square feet per ton of air conditioning. Since the home has 2,000 square feet of conditioned space, HVAC contractors could well



provide 3.5 to 4 tons of cooling ($2,000 \div 600 = 3.33$, then round up.) The oversized unit would have cost more to install. In addition, the operating costs would be higher. The oversized unit would suffer greater wear and may not provide adequate dehumidification.

Proper sizing includes designing the cooling system to provide adequate dehumidification. In a mixed-humid climate, it is important to calculate the latent load. The latent load is the amount of dehumidification needed for the home. If the latent load is ignored, the home may become uncomfortable due to excess humidity.

The Sensible Heating Fraction (SHF) designates the portion of the cooling load for reducing indoor temperatures (sensible cooling). For example, in a HVAC unit with a 0.75 SHF, 75% of the energy expended by the unit goes to cool the temperature of indoor air. The remaining 25% goes for latent heat removal—taking moisture out of the air in the home. To accurately estimate the cooling load, the designer of a HVAC system must also calculate the desired SHF and thus, the latent load.

Many homes in Climate Zone 4 have design SHFs of approximately 0.7. This means that 70% of the cooling will be sensible and 30% latent. Systems that deliver less than 30% latent cooling may fail to provide adequate dehumidification in summer. It takes 15 minutes for most air conditioners to reach peak efficiency. During extreme outside temperatures (under 32°F in winter and over 88°F in summer), the system should run about 80% of the time. Oversized systems cool the home quickly and often never reach their peak operating efficiency.

TEMPERATURE CONTROLS

The most basic type of control system is a heating and cooling thermostat. Programmable thermostats, also called setback thermostats, can be big energy savers for homes. These programmable thermostats automatically adjust the temperature setting when people are sleeping or are not at home. Be certain that the programmable thermostat selected is designed for the particular heating and cooling equipment it will be controlling. This is especially important for heat pumps, as an improper programmable thermostat can actually increase energy bills.

A thermostat should be located centrally within the house or zone. It should not receive direct sunlight or be near a heat-producing appliance. A good location is often 4 to 5 feet above the floor in an interior hallway near a return grille. The interior wall, on which it is installed, should be well sealed at the top and bottom to prevent circulation of cool air in winter or hot air in summer. Some homeowners have experienced discomfort and increased energy bills for years because air from the attic leaked into the wall cavity behind the thermostat and caused the cooling or heating system to run much longer than needed.

ZONED HVAC SYSTEMS

Larger homes often use two or more separate heating and air conditioning units for different floors or areas. Multiple systems can maintain greater comfort throughout the house while saving energy by allowing different zones of the house to be at different temperatures. The greatest savings come when a unit serving an unoccupied zone can be turned off.



Rather than install two separate systems, HVAC contractors can provide automatic zoning systems that operate with one system. The ductwork in these systems typically has a series of thermostatically controlled dampers that regulate the flow of air to each zone. Although somewhat new in residential construction, thermostats, dampers, and controls for zoning large central systems have been used for years in commercial buildings.

If your heating and air conditioning subcontractors feel that installing two or three separate HVAC units is necessary, have them also estimate the cost of a single system with damper control over the ductwork. Such a system must be carefully designed to ensure that the blower is not damaged if dampers are closed to several supply ducts. In this situation, the blower still tries to deliver the same air flow as before, but now through only a few ducts. Back pressure created against the blades of the blower may cause damage to the motor. There are three primary design options:

1. Install a manufactured system that uses a dampered bypass duct connecting the supply plenum to the return ductwork. Installing the bypass damper is the typical approach. When only one zone is open, the bypass damper, which responds automatically to changes in pressure in the duct system, will open to allow some of the supply air to take a shortcut directly back to the return, thus decreasing the overall pressure in the ductwork (Figure 7-9).
2. Create two zones and oversize the ductwork so that when the damper to one zone is closed, the blower will not suffer damage. This approach is only recommended for two zones of approximately equal heating and cooling loads.
3. Use a variable speed HVAC system with a variable speed fan for the duct system. Because variable speed systems are usually more efficient than single-speed systems, they will further increase savings.

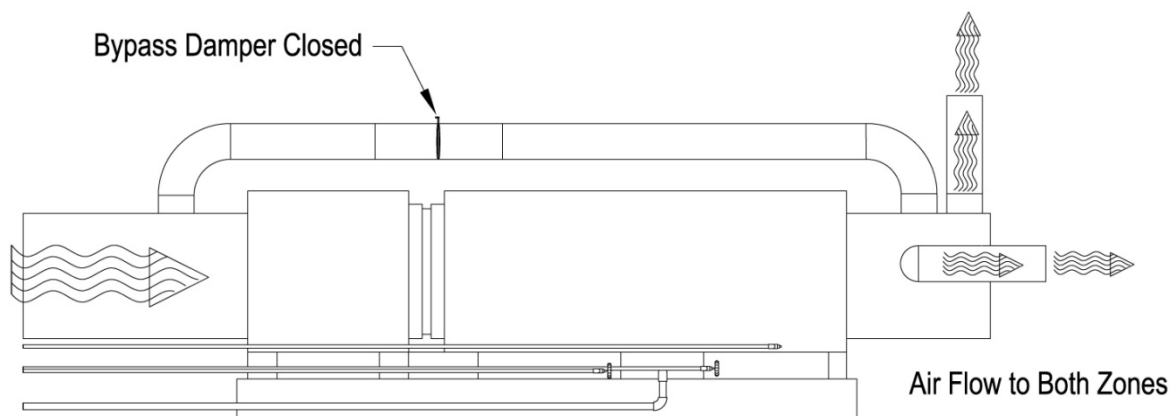

Figure 7 - 9 Automatic Zones System



COOLING EQUIPMENT SELECTION

Tables 7-4 and 7-5 show equipment charts for two sample air conditioning units. Each system provides a wide range of outputs, depending on the blower speed and the temperature conditions. The SHF (Sensible Heating Fraction) is the fraction of the total output that cools down the air temperature. The remainder of the output dehumidifies the air and is the latent cooling. Note that both systems provide about 36,000 Btu/hour of cooling.

⇒ Consider System A (Table 7-4) with 80°F return air and SEER 15:

- At low fan speed, System A provides 35,800 Btu/hour, 0.71 SHF, and thus 29% latent cooling (dehumidification).
- At high fan speed, System A provides 38,800 Btu/hour, but a 0.81 SHF, and only 19% latent cooling. This is not enough dehumidification in many Kentucky homes.

Table 7-4 Sample Cooling System A Data, SEER 15				
Total Air Volume (cfm)	Total Cooling Capacity (Btu/h)	Sensible Heating Fraction (SHF)		
		Dry Bulb (°F)		
		75°F	80°F	85°F
950	35,800	0.58	0.71	0.84
1,200	37,500	0.61	0.76	0.91
1,450	38,800	0.64	0.81	0.96

⇒ Consider System B (Table 7-5) with 80°F return air and SEER 13:

- At low fan speed, System B provides 32,000 Btu/ hour, 0.67 SHF and 33% dehumidification.
- At high fan speed, System B provides 35,600 Btu/hour, 0.76 SHF and 24% dehumidification.

Table 7-5 Sample Cooling System B Data, SEER 13				
Total Air Volume (cfm)	Total Cooling Capacity (Btu/h)	Sensible Heating Fraction (SHF)		
		Dry Bulb (°F)		
		75°F	80°F	85°F
950	32,000	0.56	0.67	0.78
1,200	34,100	0.58	0.71	0.84
1,450	35,600	0.61	0.76	0.90

Thus, System A, while nominally more efficient than B, provides less dehumidification and potentially less comfort.

VENTILATION AND INDOOR AIR QUALITY

All houses need ventilation to remove stale interior air and excessive moisture and to provide oxygen for the inhabitants. There has been considerable concern recently about how much ventilation is required to maintain the quality of air in homes. While it is difficult to gauge the severity of indoor air quality problems, building science experts and most indoor air quality specialists agree that the solution is not to build an inefficient, “leaky” home.

Research studies show that standard houses are as likely to have indoor air quality problems as energy efficient ones. While opening and closing windows offers one way to control outside air for ventilation, this strategy is rarely useful on a regular, year-round basis. Most building researchers believe that no house is so leaky that the occupants can be relieved of concerns about indoor air quality. The researchers recommend mechanical ventilation systems for all houses.

The amount of ventilation required depends on the number of occupants and their lifestyle, as well as the design of the home. The ANSI/ASHRAE standard, “Ventilation and Acceptable Indoor Air Quality in Low-Rise Residential Buildings” (ANSI/ASHRAE 62.2-2007) recommends that houses have 7.5 natural cubic feet per minute of fresh air per bedroom + 1, plus additional air flow equal to (in cubic feet per minute) 1% of the house conditioned area, measured in square feet. In addition, the standard requires exhaust fans in the kitchen and bathrooms that can be operated when needed.

For example, consider a 2,000 square foot home, with 3 bedrooms, and assume an occupancy of 4 people. The amount of ventilation recommended by ASHRAE would be 50 cfm:

$$7.5 \text{ cfm} \times (3 + 1) + 1\% \times 2,000 = 30 \text{ cfm} + 20 \text{ cfm} = 50 \text{ cfm}$$

Increasing the number of occupants or increasing the square footage of the home would increase the necessary ventilation requirements.

Older, drafty houses can have natural air leakage of 1.0 to 2.5 ACHnat. Standard homes built today are tighter and usually have rates of from 0.35 to 0.75 ACHnat. New, energy efficient homes have rates of 0.30 ACHnat or less. The problem is that air leaks are not a reliable source of fresh air and are not controllable.

The ENERGY STAR® rating system includes a consideration of homes that are tightly constructed. If the home has a measured natural air leakage rate below 0.35 ACHnat, the HERS score will not improve unless mechanical ventilation is provided. If the measured natural air leakage rate is below 0.25, the software will provide a warning that additional ventilation air should be provided and the amount needed.

Air leaks are unpredictable, and leakage rates for all houses vary. For example, air leakage is greater during cold, windy periods and can be quite low during hot weather. Thus, pollutants may accumulate during periods of calm weather even in drafty houses. These homes will also have many days when excessive infiltration provides too much ventilation, causing discomfort, high energy bills, and possible deterioration of the building envelope.

Concerns about indoor air quality are leading more and more homeowners to install controlled ventilation systems for providing a reliable source of fresh air. The simplest approach is to provide spot ventilation of bathrooms and kitchens to control moisture (see Figure 7-10). Nearly all exhaust fans in standard

construction are ineffective—a prime contributor to interior moisture problems in homes. Bath and kitchen exhaust fans should vent to the outside, not just into an attic or crawl space. General guidelines call for providing a minimum of 50 cubic feet per minute (cfm) of air flow for baths and 100 cfm for kitchens. Manufacturers should supply a cubic feet per minute (cfm) rating for any exhaust fan.

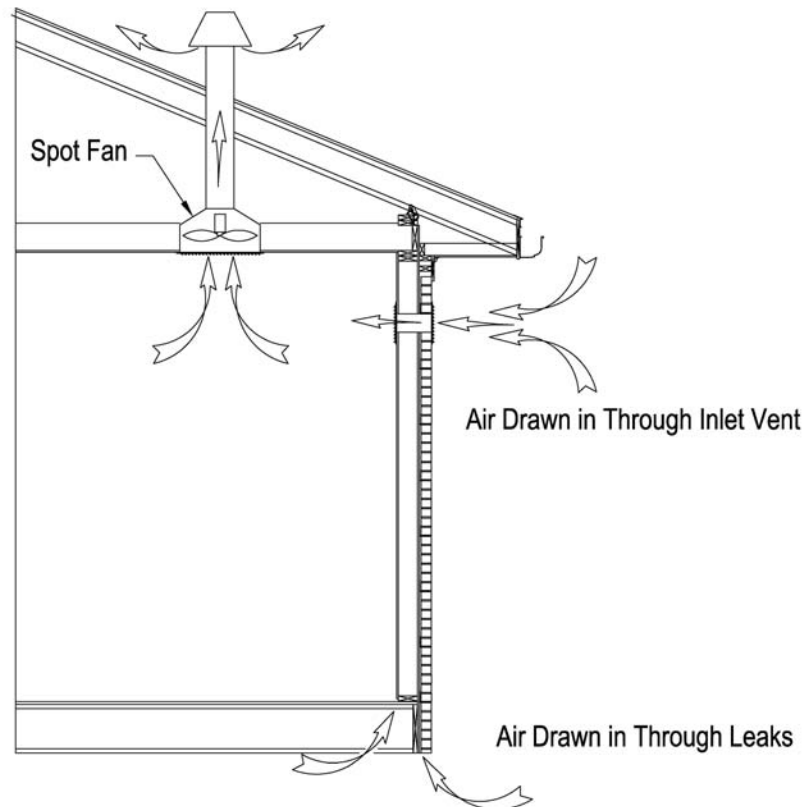

Figure 7-10 Ventilation with Spot Fan

The cubic feet per minute rating typically assumes the fan is working against an air pressure resistance of 0.1 inch of water column—the resistance provided by about 15 feet of straight, smooth metal duct. In practice, most fans are vented with flexible duct that provides much more resistance. Most fans are also rated at pressures of 0.25 to 0.30 inches of water column—the resistance found in most installations.

While ENERGY STAR® fans cost more, they are cheaper to operate and are usually better constructed and therefore, last longer and run quieter. The level of noise for a fan is measured in sones. Choose a fan with a sone rating of 2.0 or lower. Top quality models are often below 0.5 sones.

Many ceiling- or wall-mounted exhaust fans can be adapted as “in-line” blowers located outside of the living area, such as in an attic or basement. Manufacturers also offer in-line fans to vent a single bath or kitchen, or multiple rooms. Distancing the in-line fan, Figure 7-11, from the living area lessens noise problems.

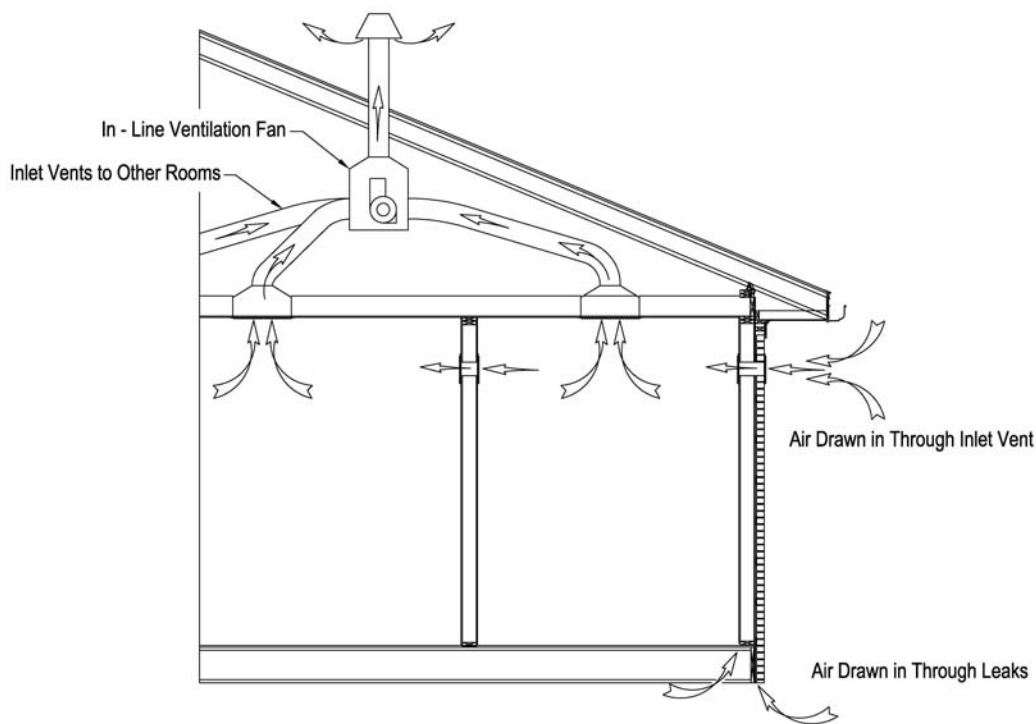

Figure 7-11 In-Line Ventilation with Spot Fan

While improving spot ventilation will certainly help control moisture problems, it may not provide adequate ventilation for the entire home. A whole house ventilation system can exhaust air from the kitchen, all baths, the main living area, and bedrooms.

Whole house ventilation systems usually have large single fans located in the attic or basement. Ductwork extends to rooms requiring ventilation. These units typically have two-speed motors. The low speed setting gives continuous ventilation—usually 10 cubic feet per minute per person or 0.35 ACH. The high speed setting can quickly vent moisture or odors.

SUPPLYING OUTSIDE AIR FROM AIR LEAKS

The air vented from the home by exhaust fans must be replaced by outside air. This new air comes into the home either through air leakage or through a controlled inlet. Relying on air leaks requires no extra equipment; however, the occupant has little control over the air entry points. Many of the air leaks come from undesirable locations, such as crawl spaces or attics. If the home is airtight, the ventilation fans will not be able to pull in enough outside air to balance the air being exhausted. This generates a negative pressure in the home, which may cause increased wear on fan motors. In addition, the exhaust fans may threaten air quality by pulling exhaust gases from flues and chimneys back into the home.



SUPPLYING OUTSIDE AIR FROM INLET VENTS

Providing fresh outside air through inlet vents is another option. These vents can often be purchased from energy specialty outlets by mail order. They are usually located in exterior walls. The amount of air they allow into the home can be controlled manually or by humidity sensors. Locate inlet vents where they will not create uncomfortable drafts. These inlet vents are often installed in bedroom closets with louvered doors or high on exterior walls.

SUPPLYING OUTSIDE AIR VIA DUCTED MAKE-UP AIR

Outside air can also be drawn into and distributed through the home via the ducts for a forced-air heating and cooling system. This type of system usually has an automatically controlled outside air damper in the return duct system.

The blower for the ventilation system is either the air handler for the heating and cooling system or a smaller unit that is strictly designed to provide ventilation air. A slight disadvantage of using the HVAC blower is that incoming ventilation air may have sufficient velocity to affect comfort during cold weather.

The return ductwork for the heating and cooling system may be connected to a small outside air duct that has a damper which opens when the ventilation fan operates. The incoming air flow should not adversely affect comfort. Special controls are available to ensure that the air handler runs a certain percentage of every hour, thus providing fresh air on a regular basis.

DEHUMIDIFICATION-VENTILATION SYSTEMS

Kentucky homes are often more humid than desired. A combined dehumidification-ventilation system can bring in fresh (but humid outdoor air), remove moisture, and supply it to the home (see Figure 7-12). These systems can also filter incoming air. These systems require an additional mechanical device. A dehumidifier must be installed on the air supply duct. This dehumidifier should be designed for the specific needs of the home.

A well-designed conventional A/C system without outdoor ventilation air should not need supplemental dehumidification. It is the excess moisture in outdoor ventilation air that may require the special dehumidification equipment, especially when mild outdoor temperatures do not require the cooling system to operate many hours per day to maintain the setpoint temperature.

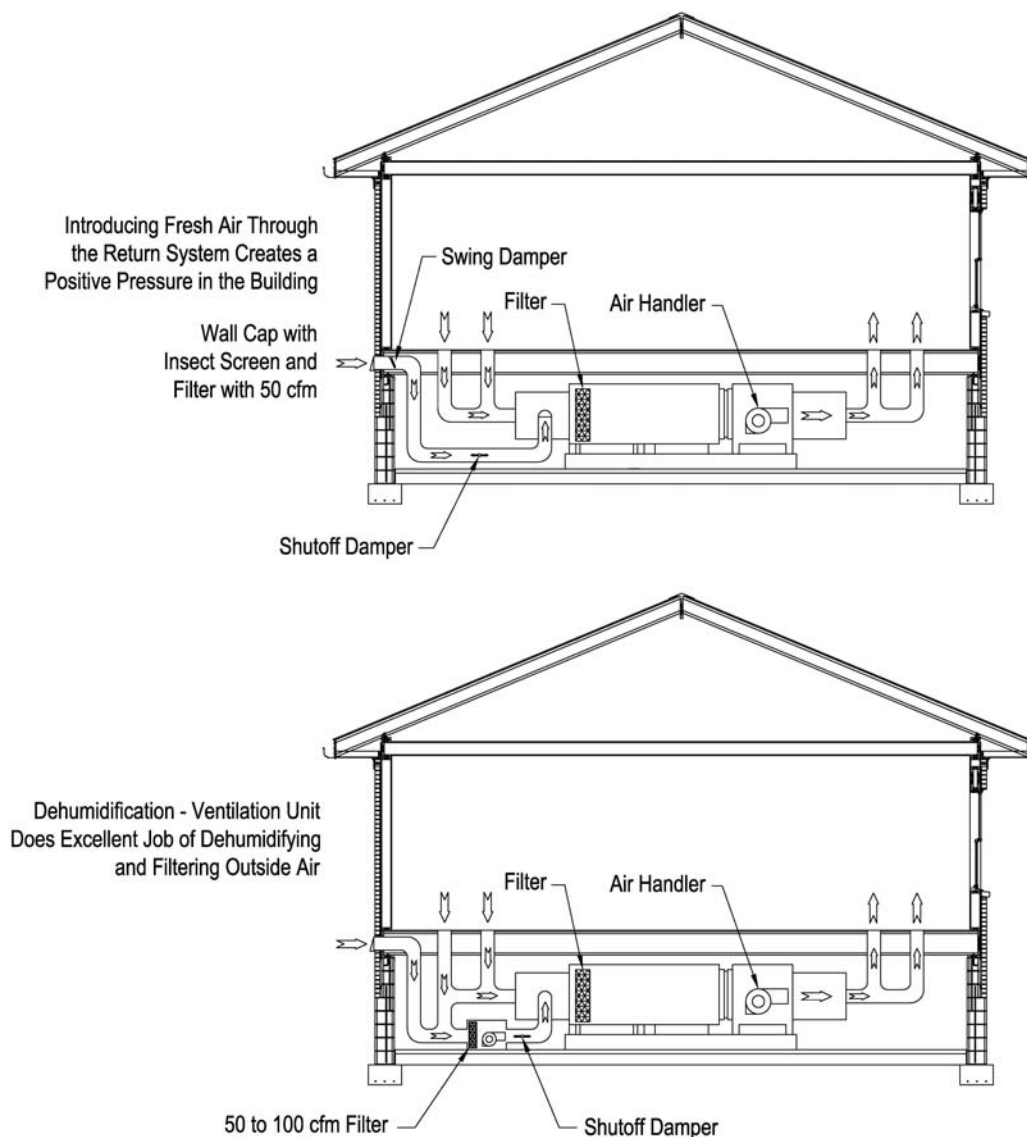

Figure 7-12 Fresh Air and Dehumidification Strategies

HEAT RECOVERY VENTILATORS

Air-to-air heat exchangers, or heat recovery ventilators (HRV), typically have separate duct systems that draw in outside air for ventilation and distribute fresh air throughout the house. Winter heat from stale room air is “exchanged” for the cooler incoming air. Some models, called enthalpy heat exchangers, can also recapture cooling energy in summer by exchanging moisture between exhaust and supply air.

While energy experts have questioned the value of the heat saved in Kentucky homes for the \$400 to \$1,500 cost for an HRV, recent studies on enthalpy units indicate their dehumidification benefit in

summer offers an advantage over ventilation-only systems. The value of any heat recovery ventilation system should not be determined solely on the cost of recovered energy. The controlled ventilation and improved quality of the indoor environment must be considered as well.

SAMPLE VENTILATION PLANS

Three options for providing a mechanical ventilation system for a home are shown in the following designs. While providing mechanical ventilation plans is routine for commercial buildings, their use in homes is just beginning. As a result, few standard designs exist and some time will be needed for them to be developed for different climates.

DESIGN 1: UPGRADED SPOT EXHAUST VENTILATION

This relatively simple and inexpensive whole house ventilation system, Figure 7-13, integrates spot ventilation using bathroom and kitchen exhaust fans with an upgraded exhaust fan (usually 100 to 150 cfm) in a centrally located bathroom. When the fan operates, outside air is drawn through inlets in closets with louvered doors. A timer, set to provide ventilation at regular intervals, controls the fan. Interior doors are undercut to allow air flow to the central exhaust fan. The fan must be a long-life, high-quality unit that operates quietly. In addition to the automatic ventilation provided by this system, occupants can turn on all exhaust fans manually as needed.

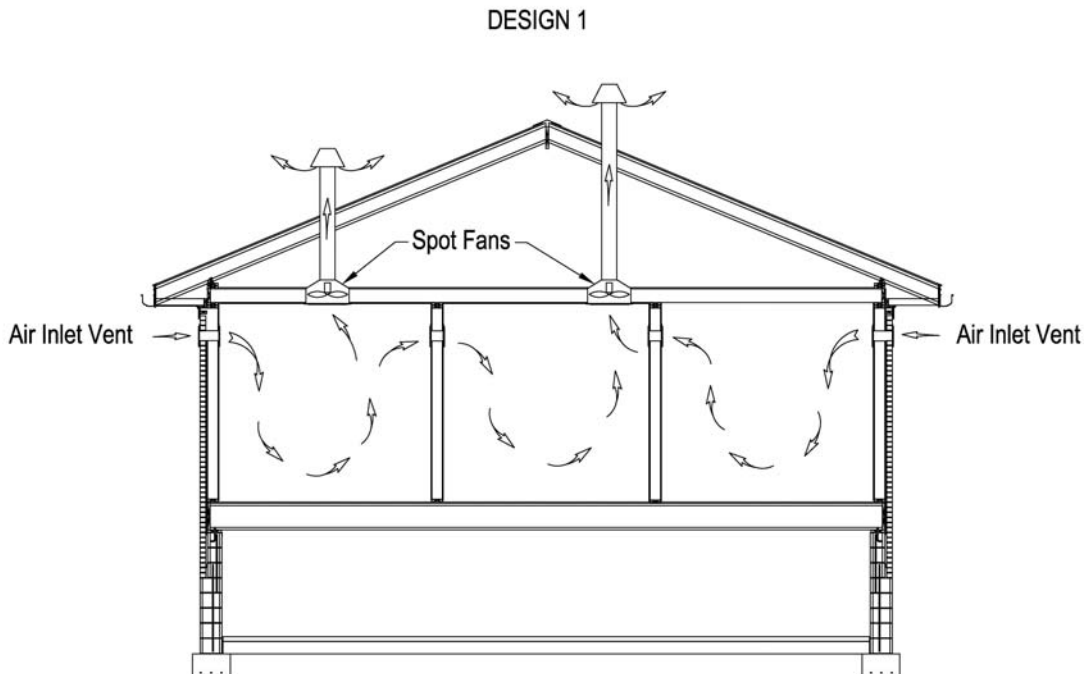

Figure 7-13 Upgraded Spot Exhaust Ventilation

DESIGN 2: WHOLE HOUSE VENTILATION SYSTEM

This whole house ventilation system uses a centralized two-speed exhaust fan to draw air from the kitchen, bath, laundry, and living areas. A timer controls the blower. The system should provide approximately 0.35 natural air changes per hour (ACHnat) on low speed and 1.0 ACHnat on high speed. A separate dampered duct connected to the return air system supplies outside air. When the exhaust fan operates, Figure 7-14, the outside air damper opens and allows air to be drawn into the house through the forced-air ductwork.

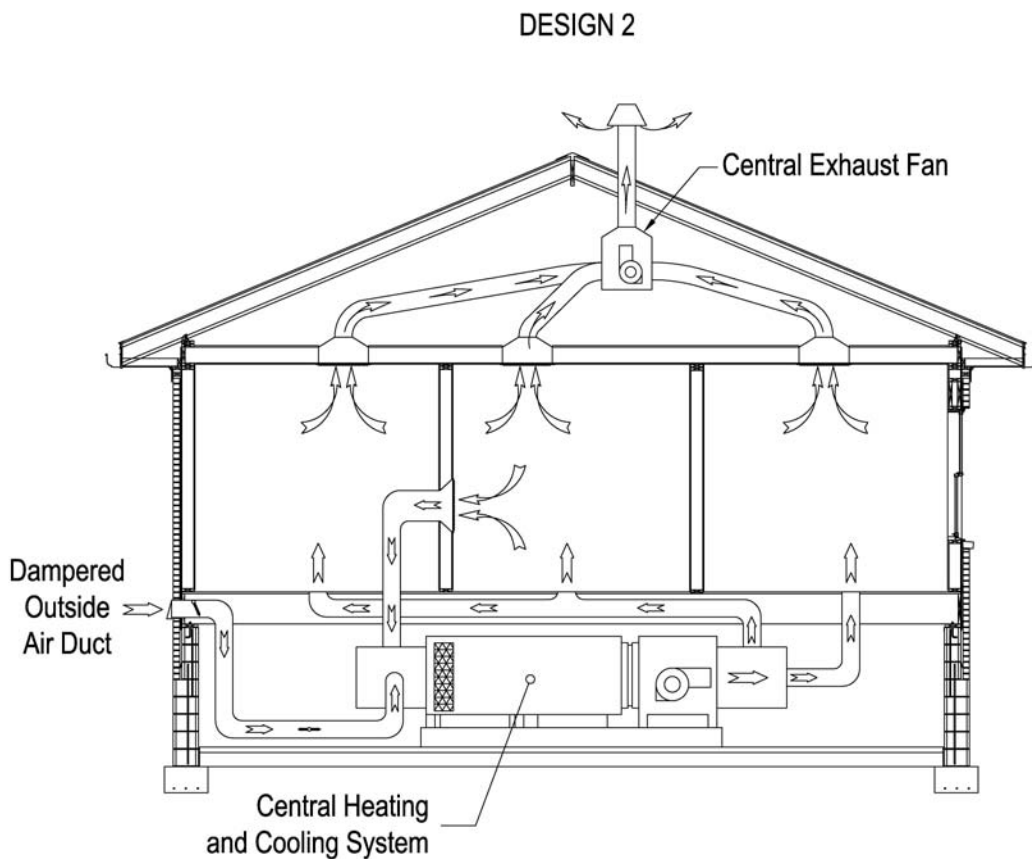

Figure 7-14 Whole House Ventilation System

DESIGN 3: HEAT RECOVERY VENTILATION (HRV) SYSTEM

An enthalpy recovery ventilator draws fresh outside air through a duct into the heat exchange equipment and recaptures heating or cooling energy from stale room air as it is being exhausted (see Figure 7-15). The system also dries incoming humid air in summer. This is a particular benefit in the Southeast. Fresh air flows into the house via a separate duct system, which should be sealed as tightly as the HVAC ductwork. Room air can either be ducted to the exchanger from several rooms or to a single source. Some HRV units can be wall-mounted in the living area, while others are designed for utility rooms or basements.

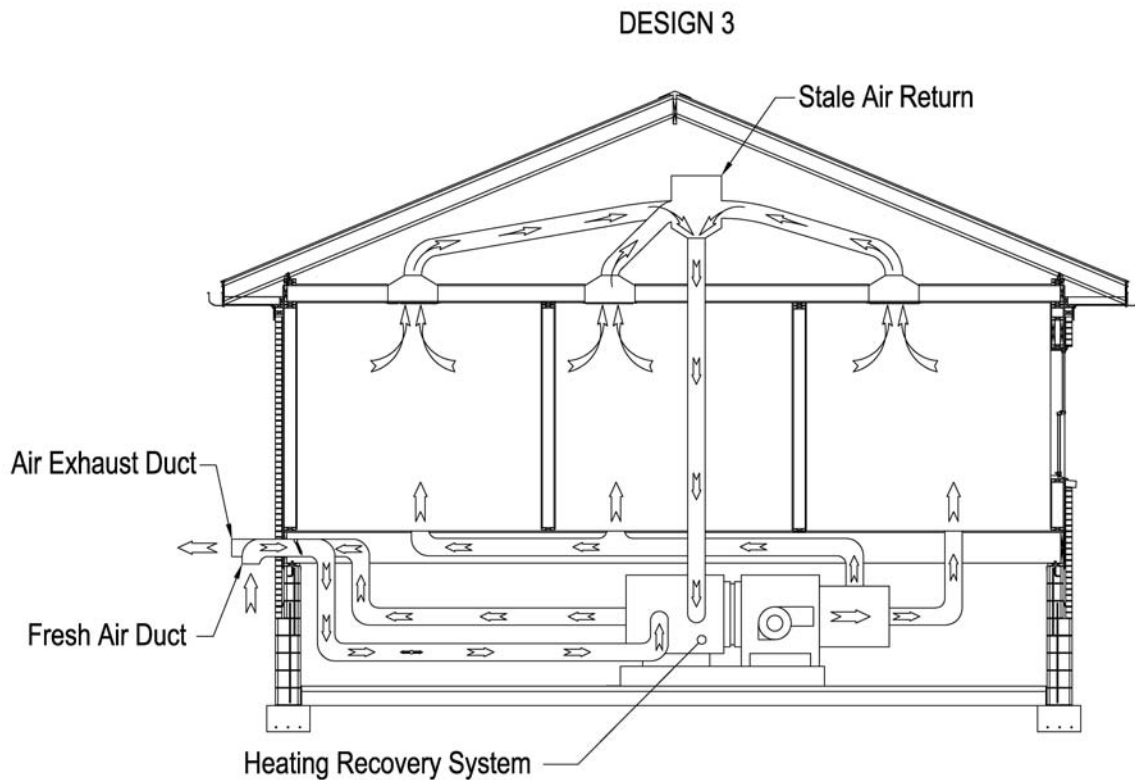

Figure 7-15 Heat Recovery Ventilation (HRV) System



RADON

Radon is a cancer-causing, radioactive gas that is found in soils throughout the United States. Although you cannot see, smell or taste radon, it can become concentrated at dangerous levels in any building, including homes, offices, and schools. People are most likely to get the greatest exposure at home because most time is spent there.

REMOVING RADON

Ventilating under the foundation will help remove radon and other soil gases, such as moisture vapor, before they have a chance to enter the home. It is more cost-effective to include any radon resistant techniques while building a home, rather than retrofitting an existing home. A typical installation during construction will cost the homeowner roughly \$50 to \$300, whereas retrofitting an existing home can cost up to \$2,000. In addition, no operating costs are associated with this passively vented system. If elevated radon levels are found in the home, a fan can be added easily to make an active system.

Figure 7-16 shows the basics of radon resistant construction for crawl spaces and slabs/basement foundation types.

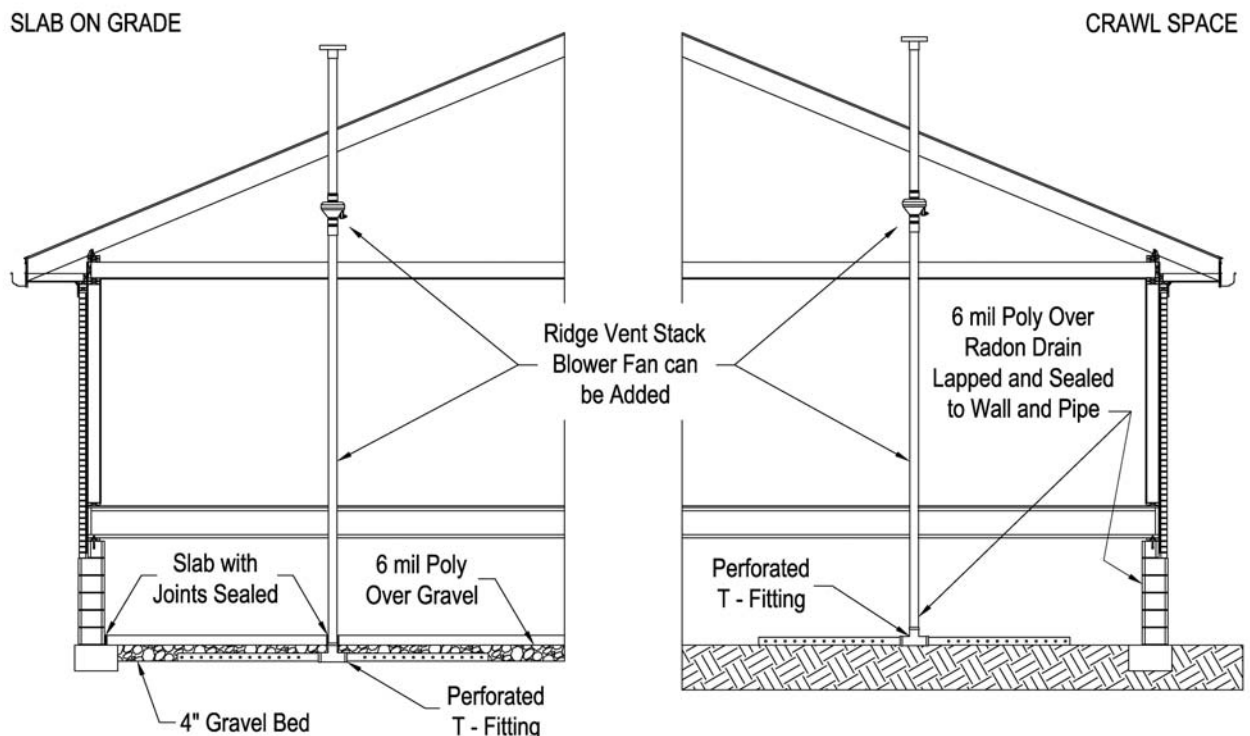

Figure 7-16 Radon Resistant Construction



PASSIVE AND ACTIVE RADON RESISTANT CONSTRUCTION

Passive concept: a perforated “T” fitting is attached to a vertical plastic vent stack that penetrates the roof. The “T” is buried in the gravel under the foundation slab and gases can slowly percolate through the “T” and out the stack.

Active concept: if unacceptable levels of radon are still present, after checking the radon levels from a passive system, a fan can be added to generate suction to pull gases out through the stack.

SLAB-ON-GRADE OR BASEMENT

- Use a 4 to 6 inch gravel base.
- Install continuous layer of 6-mil polyethylene.
- Stub in “T” below polyethylene that protrudes through polyethylene and extends above poured floor height.
- Pour slab or basement floor.
- Seal slab joints with caulk.

CRAWL SPACE

- Install sealed, continuous layer of 6-mil polyethylene.
- Install “T” below polyethylene that protrudes through polyethylene.

ALL FOUNDATIONS

- Install a vertical 3-inch PVC pipe from the foundation to the roof through an interior wall.
- Connect the “T” to the vertical 3-inch PVC pipe for passive mitigation.
- Have electrician stub-in junction box in attic.
- Label PVC pipe “RADON” so that future plumbing work will not be tied into the stack.

TESTING FOR RADON

After building a radon resistant home, it is still recommended to test the home for elevated radon levels. Low-cost “do-it-yourself” radon test kits can be obtained through the mail, in hardware stores, and other retail outlets, and possibly from your local government. If desired, a trained contractor can be hired to do the testing. Make certain that the contractor is certified by the National Environmental Health Association (NEHA).

WHAT IF HIGH LEVELS ARE FOUND?

With the basics of a radon mitigation system already installed, it is relatively inexpensive and easy to make the system active. Adding an in-line fan, rated for continuous operation, is a relatively simple addition that will ensure the safe removal of radon from beneath the home.



CHAPTER 8: DUCT DESIGN AND SEALING

Studies conducted throughout the country have found that poorly sealed ductwork is often the most prevalent and yet an easily solved problem in new construction. Duct leakage contributes 10% to 30% of heating and cooling loads in many homes. In addition, duct leakage can lessen comfort and endanger health and safety.

Locating ducts in conditioned space eliminates many problems with leakage. Ducts are often installed in chases, the framed air passageways situated behind the ceiling or wall finish. The chases are connected more directly to unconditioned space than to interior space. Thus, it is critical to seal chases and other hidden areas completely from unconditioned spaces.

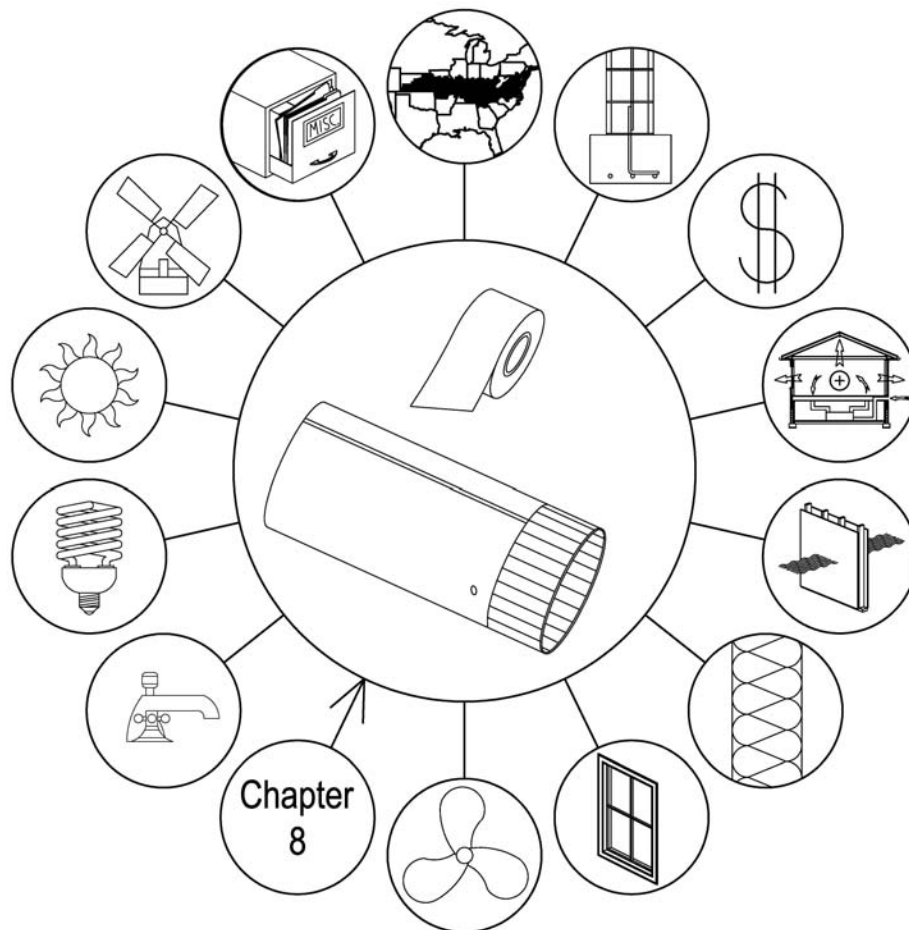



DUCT LEAKS AND AIR LEAKAGE

The International Energy Conservation Code (IECC) requires that HVAC contractors use effective materials to seal duct leaks. Effective materials for sealing include duct-sealing mastic with mesh tape or rated tapes that are UL-labeled.

The best way to minimize duct leakage energy loss is to install the entire duct system within the conditioned space. This requires careful planning of the duct system when a house is being designed.

The IECC provision reflects the universal recognition that limiting duct leakage not only saves energy, but also improves comfort, and makes our homes healthier places in which to live. Chapter 3 explained, in detail, some of the health risks of leaky ductwork. Builders should ensure the quality of the duct system by having a duct tightness test. Kentucky has a variety of energy efficiency contractors and home energy raters who conduct air and duct leakage testing.

Forced-air heating and cooling systems should be balanced. The amount of air delivered through the supply ducts should be equal to the amount of air drawn through the return ducts. If the two volumes of air are unequal, then the pressure of the house can be affected. Pressure imbalances can increase air leakage into or out of rooms in the home.

Pressure imbalances can create dangerous air quality in homes including:

- Potential backdrafting of combustion appliances, such as fireplaces, wood stoves and gas burners;
- Increasing air leakage from the crawl space to the home. This may draw in dust, radon, mold, and humidity; and
- Pulling pollutants into the air handling system via return leaks.

Typical causes and concerns of pressure imbalances, addressed more fully in Chapter 4, include:

- HVAC systems with excessive supply leaks can cause homes to become depressurized, which may cause backdrafting of combustion appliances in the home.
- HVAC systems with excessive return leaks can cause homes to become pressurized and create negative pressures around the air handling unit. The negative pressures may cause combustion appliances near the air handling unit to backdraft.
- Homes with central returns can have pressure imbalances when the interior doors to individual rooms are closed. The rooms with supply registers and no returns become pressurized, while the areas with central returns become depressurized. Often these returns are located in living rooms with fireplaces or combustion appliances. When these spaces become sufficiently depressurized, the flues will backdraft.
- Tighter homes with effective exhaust fans, such as kitchen vent hoods, clothes dryers, and attic ventilation fans, may experience negative pressures when these ventilation devices operate.
- Large kitchen exhaust fans, moving more than 200 cubic feet per minute, can easily create large pressure imbalances in the home.

TESTING FOR DUCT LEAKAGE

The best method to ensure airtight ducts is to pressure test the entire duct system, including all boot connections, duct runs, plenums, and the air handler cabinet (see Figure 8-1). Much like a pressure test required for plumbing, ductwork should be tested during construction so that problems can be easily corrected.



In most test procedures, a technician temporarily seals the ducts by taping over the supply registers and return grilles. Then, the ducts are pressurized to a given pressure, typically 25 Pascals, using a duct testing fan. This pressure is comparable to the average pressure the ducts experience when the air handler operates. While the ducts are pressurized, the technician can read the total duct leakage of the HVAC system.

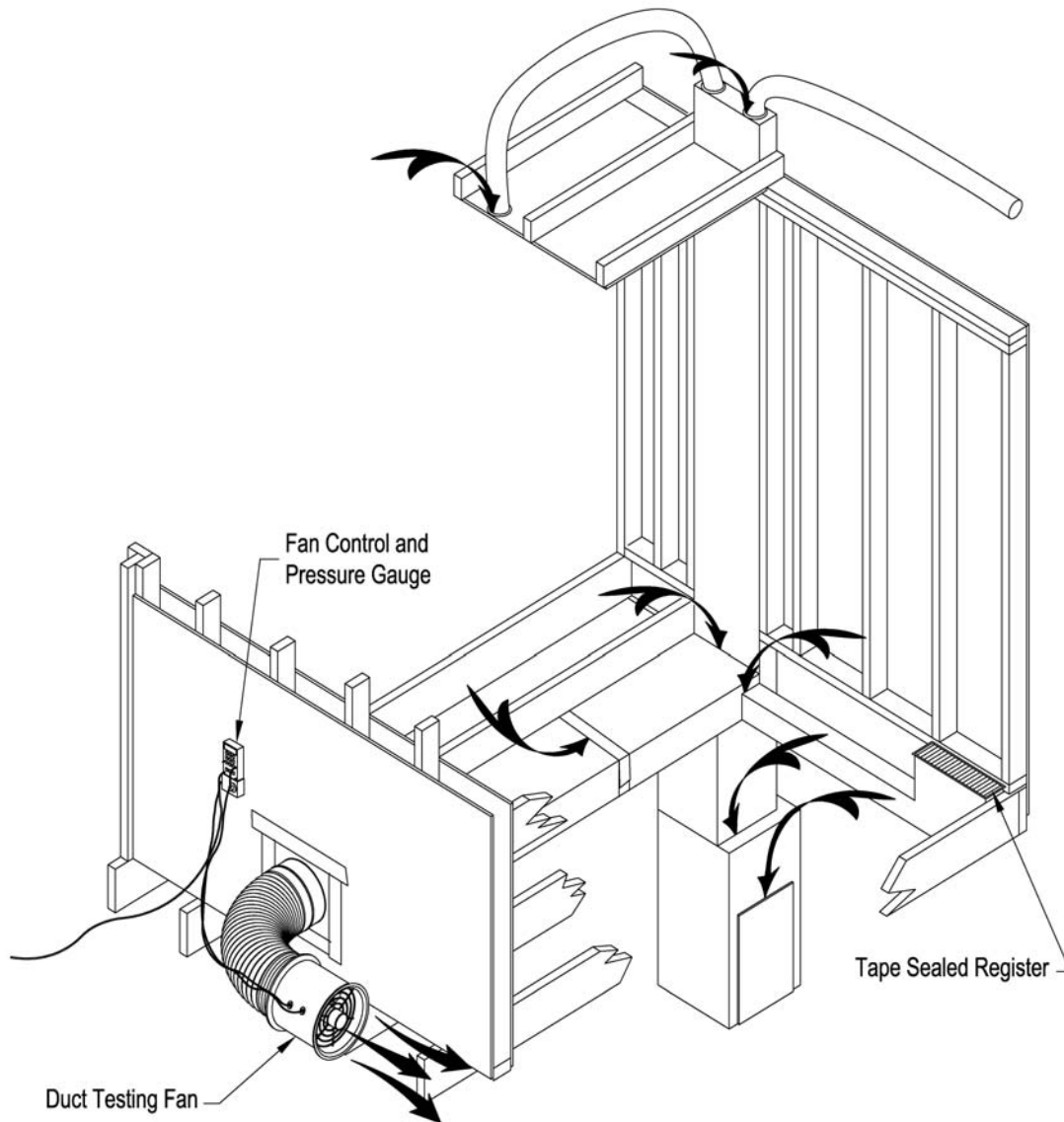

Figure 8 - 1 Leakage Inspection for Air Ducts



Some energy efficiency programs require that the cubic feet per minute of duct leakage, measured at a 25 Pascal pressure (CFM25), be less than 3% of the floor area of the house. For example, a 2,000 square foot house should have less than 60 CFM25 of duct leakage.

Another test is to use both a blower door (described in Chapter 4) and a duct-testing fan to measure duct leakage after construction is complete. This procedure gives the most accurate measurement of duct leakage to the outside of the home. A duct leakage test can usually be done in about one hour for an average sized home.

SEALING AIR DISTRIBUTION SYSTEMS

Duct leakage should be eliminated. In standard construction, many duct seams are not sealed or are poorly sealed using ineffective materials. Some of these ineffective materials, including cloth “duct tape,” unrated aluminum tape, or similar products, use lower quality adhesives. These lower quality adhesives are not designed to provide an airtight seal over the life of the home, mainly due to the slight expansion and contraction of the duct. Be sure to use only the following products for sealing the components of the air distribution system:

- Duct sealing mastic with fiberglass mesh tape. This mastic is highly preferred and may add \$20 to \$55 to the cost of a \$7,000 system, but will provide a lifetime, airtight seal.
- High quality caulking or foam sealant; and
- Aluminum UL-181 A or B tape. However, it must be installed properly to be effective. The duct surface must be clean of oil and dirt. The tape must fully adhere to the duct with no wrinkles. A squeegee must be used to remove air bubbles from beneath the taped surface. UL-181 tape costs only \$4 to \$5 more than “silver tape,” which has an inferior adhesive.

Proper sealing and proper insulation of the ductwork in unconditioned areas require careful attention to detail (see Figure 8-2). Extra time is needed on the part of the heating and air conditioning contractor. The cost of this extra time is well worth the substantial savings on energy costs, improved comfort, and better air quality that an airtight duct system offers.

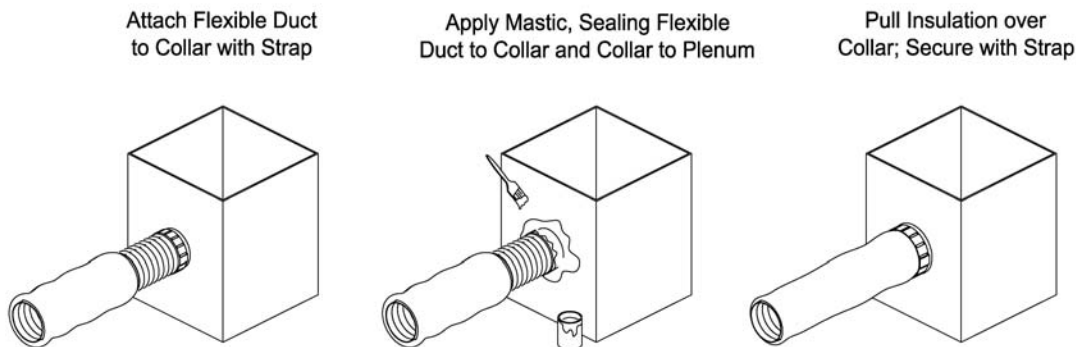

Figure 8 - 2 Upgraded Exhaust Ventilation



The supply duct, in Figure 8-3, is theoretically in conditioned space; the supply leaks pressurize the band joist area and air leaks to the outside. The best solution is to seal all duct leaks and all building envelope air leaks. ⇒ *The easiest answer to the question of where to seal the air distribution system is “everywhere.”*

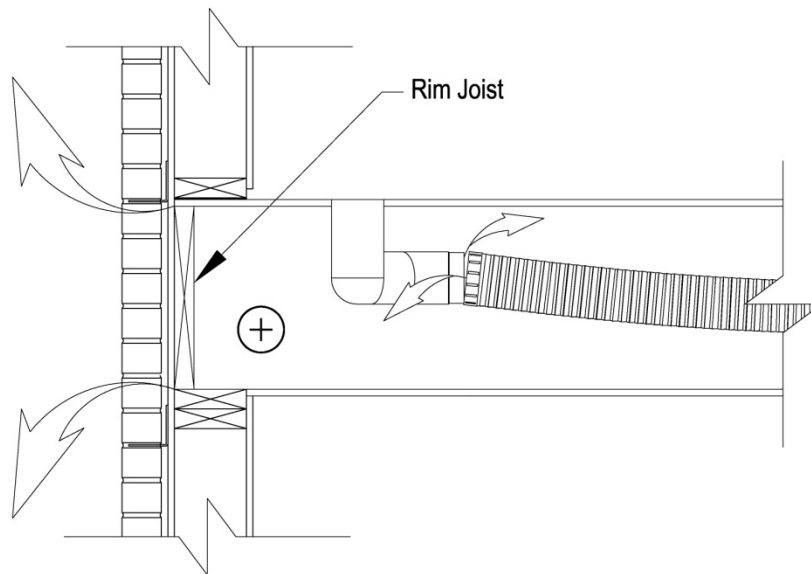

Figure 8 - 3 Dislodged Boot in Floor Space

HIGH PRIORITY LEAKS

Areas that have the highest priority for sealing include:

- Disconnected components, including takeoffs that are not fully inserted, plenums or ducts that have been dislodged, tears in flex-duct, and strained connections between ductwork (visible when the duct bends where there is no elbow), Figure 8-4. Ducts can become disconnected during initial installation, maintenance, or even normal operation. They should be checked periodically for problems. Dislodged ducts can be hidden behind insulation (Figure 8-5); look for gaps and depressions where there is no elbow.
- The connections between the air handling unit and the supply and return plenums.
- All of the seams in the air handling unit, plenums, and rectangular ductwork. Look particularly underneath components and in any other tight areas. Also, seal the holes for the refrigerant, thermostat, and condensate lines. Use tape rather than mastic to seal the seams in the panels of the air handling unit so they can be removed during servicing. After completion of service and maintenance work, such as filter changing, make sure that the seams are re-taped. Virtually all air handling cabinets come from the factory with leaks, which should be sealed with duct-sealing mastic (Figure 8-6); removable panels should be sealed with tape.
- The condensate lines of many systems contain a trap with a vertical vent that freely leaks air



- The return takeoffs, elbows, boots, and other connections. If the return is built into an interior wall, all connections and seams must be sealed carefully. Look especially for unsealed areas around site-built materials.
- The takeoffs from the main supply plenum and trunk lines.
- Any framing in the building used as ductwork, such as a “panned” joist in which sheet metal, nailed to floor joists, provides a space for conditioned air to flow. Avoid using framing as a part of the duct system.
- Sealing a joint that will be inaccessible will help ensure that the joint never comes apart and then require expensive refinishing of a wall or ceiling after it is repaired.

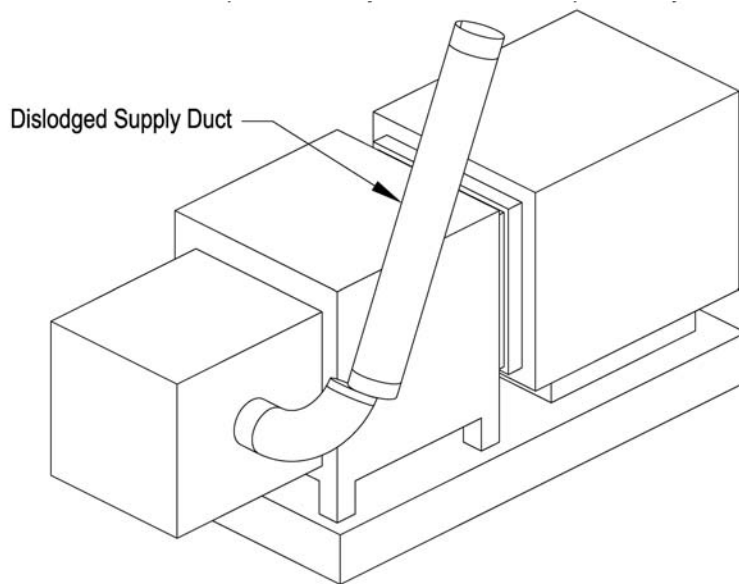

Figure 8 - 4 Disconnected Ducts are High Priority

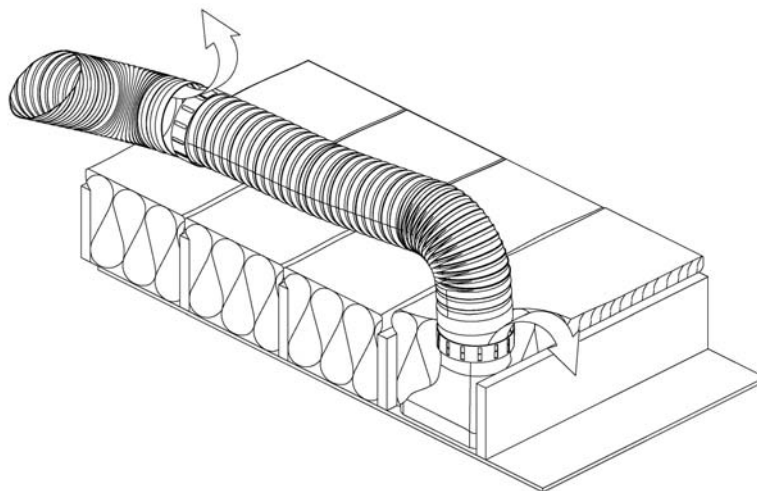

Figure 8 - 5 Dislodged Boot

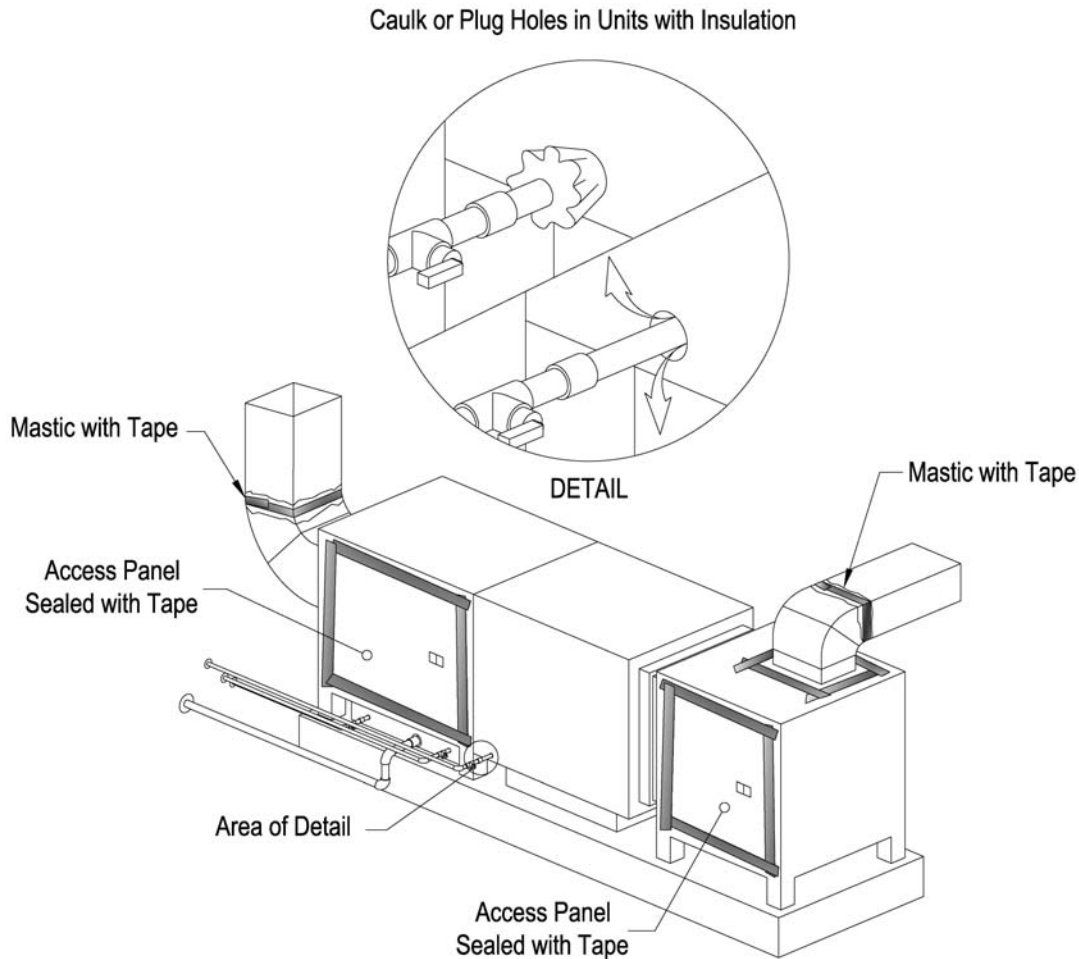

Figure 8 - 6 Sealing Leaks in Air Handler Unit

MODERATE PRIORITY LEAKS

Once all of the high priority leaks have been sealed, consider the following areas:

- The connections near the supply registers. Check for potential leaks in all areas, including between the branch ductwork and the boot, the boot and the register, and the seams of the elbows (see Figures 8-7 and 8-8).
- The joints between sections of the branch ductwork.

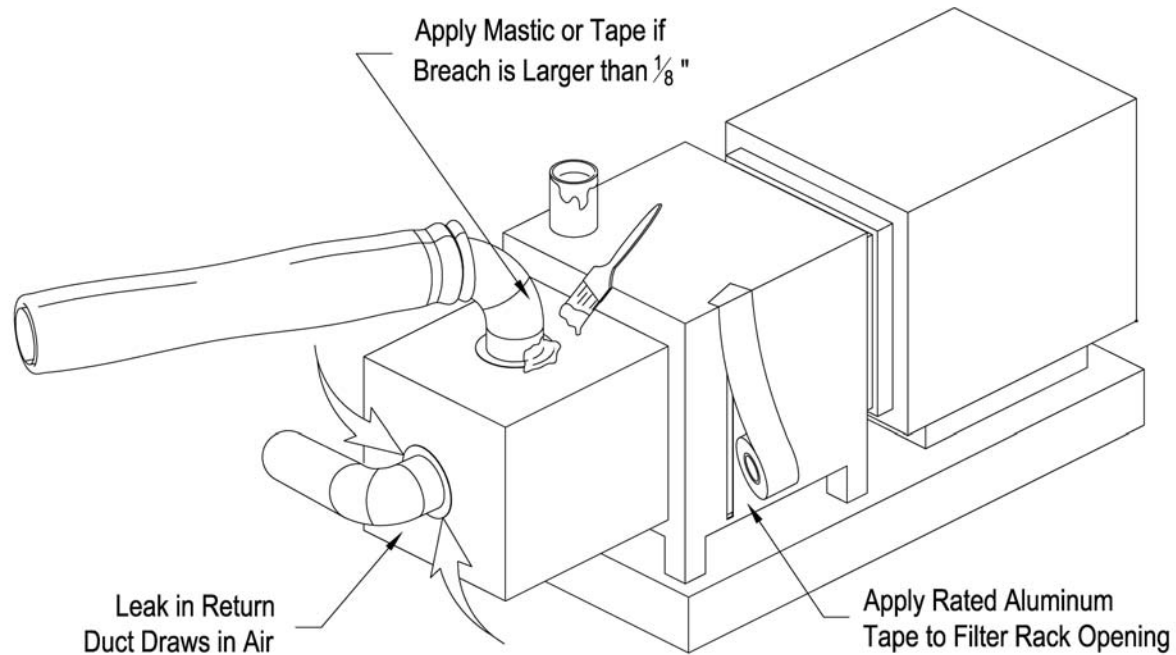
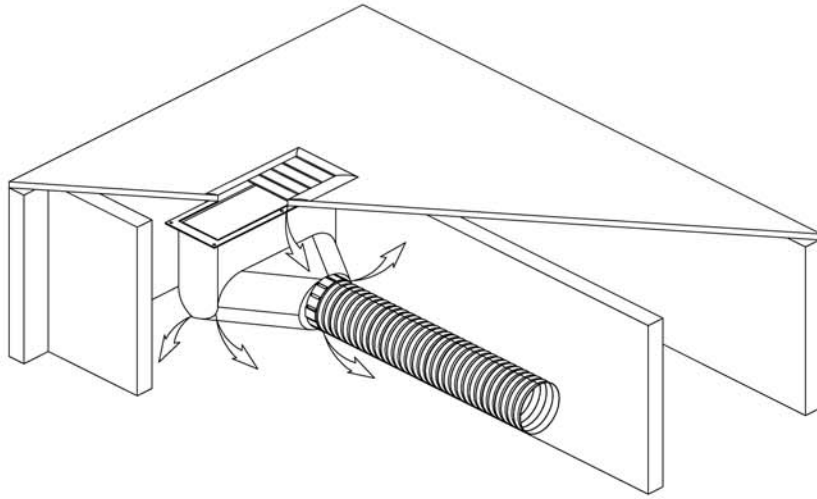

Figure 8 - 7 Seal All Duct Leaks

LOW PRIORITY LEAKS

Finally, seal these low priority leaks:

- Longitudinal seams in round metal ductwork.



Completely Seal All Seams and Holes
Use Mastic and Tape for Cracks over $\frac{1}{8}$ "

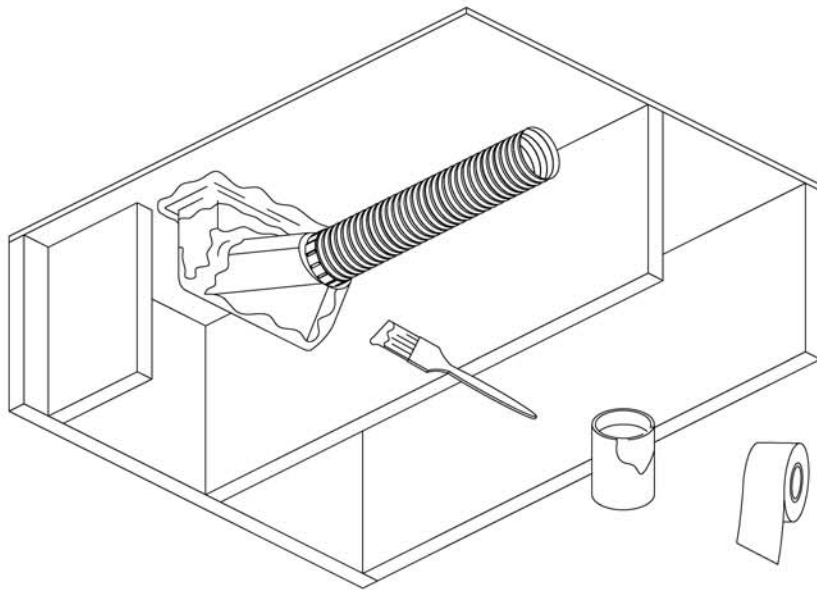

Figure 8 - 8 Seal Leaky Boots



DUCT DESIGN

DUCT MATERIALS

The three most common types of duct material used in home construction are metal, fiberglass duct board, and flex-duct (see Figure 8-9). Both metal and fiberglass duct board are rigid and installed in pieces. Flexible duct comes in long sections.

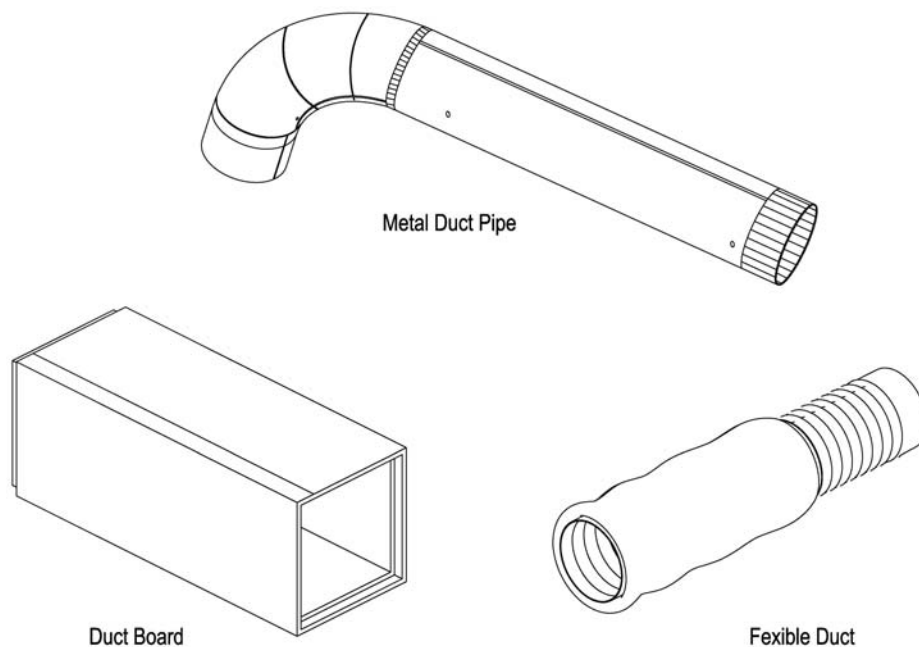

Figure 8 - 9 Types of Duct Material

Flexible duct is usually installed in long, continuous pieces between the register and plenum box, the plenum box and air handler, or between the register and air handler. Long flex-duct runs can severely restrict air flow, so they should be sized and installed carefully. Flex-duct runs should not be pinched or constricted. Flexible duct takeoffs, while often airtight in appearance, can have substantial leakage and should be sealed with mastic.

Round and rectangular metal ducts must be sealed with mastic and insulated during installation. It is important to seal the seams in the ductwork before insulating, because the insulation does not stop air leaks.

Rectangular metal ducts, used for plenums and larger trunk duct runs, are often insulated with duct liner, a high density material that should be at least 1 inch thick.



Metal ducts often use fiberglass insulation having an attached metal foil vapor retarder. The duct insulation should be at least R-8, and the vapor retarder should be installed to the outside of the insulation—facing away from the duct. The seams in the insulation are usually stapled together around the duct and then taped. Duct insulation in homes at least two years old provides great clues about duct leakage. When the insulation is removed, the lines of dirt in the fiberglass often show where air leakage has occurred.

SIZING AND LAYOUT

The size and layout of the ductwork affect the efficiency of the heating and cooling system and the comfort levels in the home. The proper duct size depends on the following items.

- The estimated heating and cooling load for each room in the house;
- The length, type, and shape of the duct; and
- The operating characteristics of the HVAC system (such as the pressure, temperature, and fan speed).

The layout of the ductwork will affect the amount of air that the duct can deliver, Figure 8-10. Length and curvature influence the flow rates. A simple round metal duct, which has been improperly laid out, could have a reduced air flow.

The lower temperature of the heated air, delivered by a heat pump, affects the placement of the registers. A heat pump usually supplies air, heated between 90°F and 110°F. At these temperatures, air leaving registers may feel cool. It is important that the registers be placed to avoid blowing air directly onto people. Fuel-fired furnaces typically deliver air, heated to temperatures between 110°F and 140°F. This is 40°F to 70°F greater than room temperature; therefore, placement of the supply registers is less important to maintain comfort.

In standard duct placement and design, supply registers are usually located on outside walls under or above windows, and return registers are placed towards the interior, typically in a central hallway.

Some builders of energy efficient homes have found little difference in temperature between interior areas and exterior walls because of the extra energy features. Locating the supply registers on exterior walls is not as necessary to maintain comfort. These builders are able to trim both labor and material costs for ductwork by locating supply and return ducts near the core of the house.

In standard duct design, virtually all supply ducts are 6-inch flex-duct or round metal pipe. Most standard designs have only one return for each floor.

Keeping all ducts a standard size may work for some homes, but can create operating problems for others, including:

- Too much heating and cooling supplied to small rooms, such as bathrooms and bedrooms with only one exterior wall;
- Inadequate airflow, and thus, insufficient heating and cooling in rooms located at the greatest distance from the air handler; and
- Over pressurization of rooms when interior doors are closed.

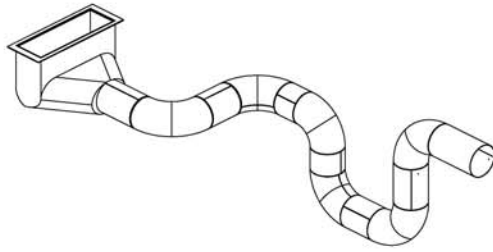

(100 CFM) - Long, Convoluted, Round Metal Duct

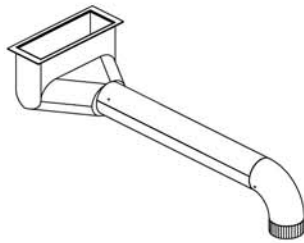

(130 CFM) - Straight, Short, Round Metal Duct

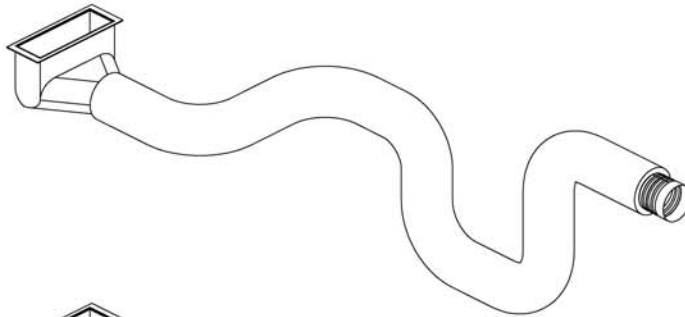

(75 CFM) - Long, Convoluted, Flexible Duct

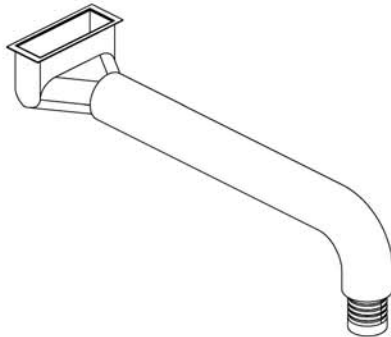

(110 CFM) - Straight, Short, Flexible Duct

Figure 8 - 10 Duct Configuration Flow Rates



The heating and cooling industry has comprehensive methods to size supply and return ductwork properly. These procedures are described fully in Manual D, Duct Design, published by the Air Conditioning Contractors of America.

Unfortunately, few residences have ductwork designed via Manual D. The primary "design" is determining, usually via intuition, how many 6-inch ducts to install in each room.

Figure 8-11 shows the size ductwork Manual D would specify for a small home. The design is vastly different from the typical, all 6 inch system. The advantage of proper design is that each room receives air flow proportionate to its heating and cooling load, thus increasing overall comfort and efficiency.

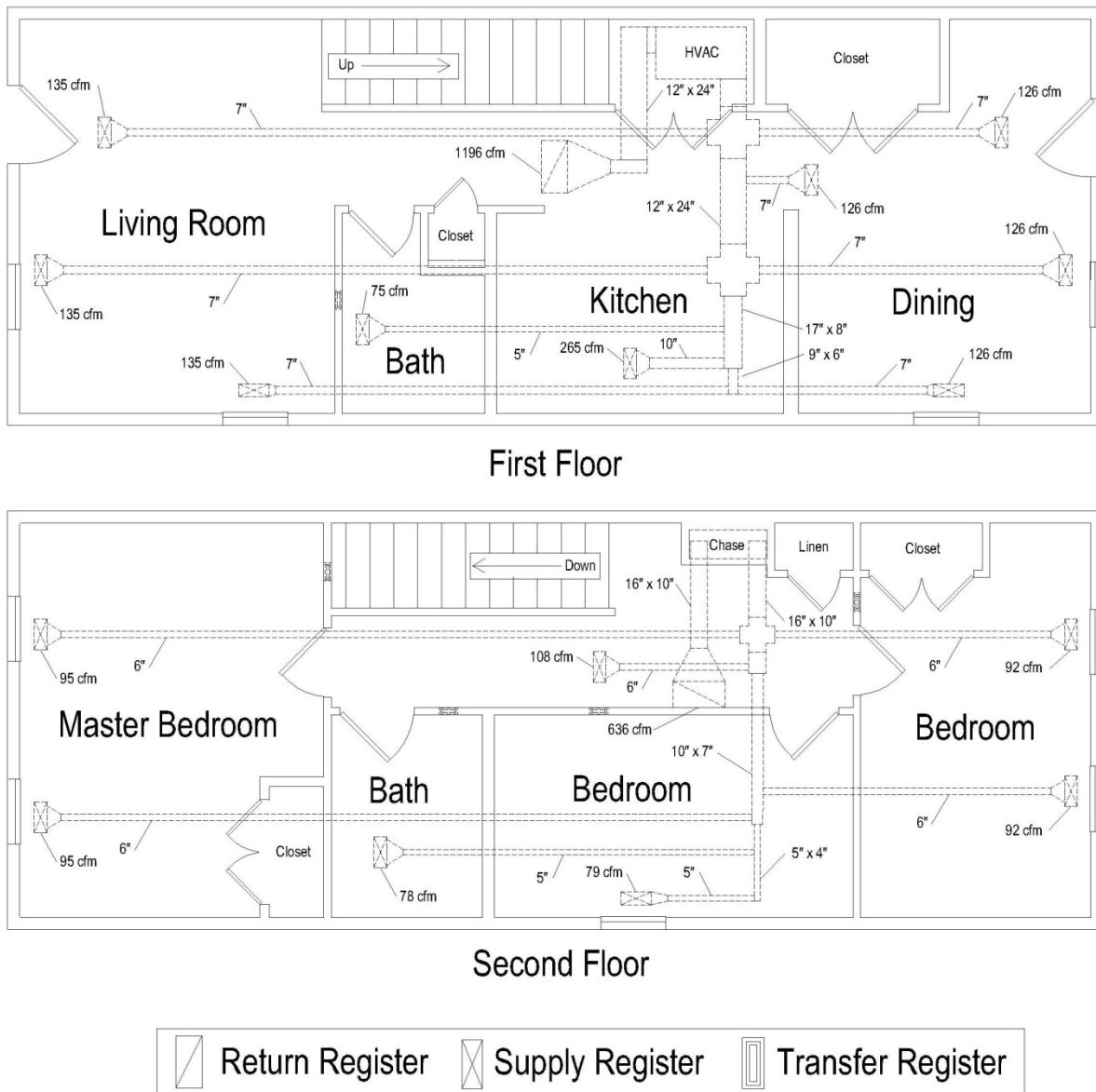

Figure 8 - 11 Duct Design Using Manual D



Ductwork Summary

Supply	
Size	Number
5"	3
6"	5
7"	7
10"	1

The following recommendations, while no substitute for a Manual D calculation, should improve system performance:

- If two rooms have similar orientation, window area, and insulation characteristics, but one room is considerably farther from the air handling unit than the other, consider increasing the size of the ductwork going to the farthest room;
- Bonus rooms over garages often need additional or larger supplies;
- Rooms with large window areas may warrant an extra supply duct, regardless of the room size; and
- Large rooms with few windows, one wall exposed to the exterior, a well insulated floor, and a conditioned space above may need only one small duct.



CHAPTER 9: WATER HEATING

Energy costs for water heating can be as great as the costs for heating, for an energy efficient house, in a mild climate. Estimating hot water usage in a home is difficult because of the wide differences in water use habits. Estimates for a family of four, with one person at home, could be as high as 90 gallons of hot water used per day; a family of two, with both working, could use as few as 50 gallons per day. However, it is possible to cut the cost of water heating with conservation measures and water heating alternatives.

Water heaters come in a range of efficiencies, warranties, and fuel sources. Their efficiencies are measured by a rating known as the *energy factor* (EF). The energy factor is a measure of the overall efficiency of a water heater and includes recovery efficiency, standby losses, and cycling losses. The EnergyGuide sticker on a water heater can be used to compare the estimated annual energy cost for a specific water heater with comparable models. Chapter 10 describes the EnergyGuide sticker in more detail.

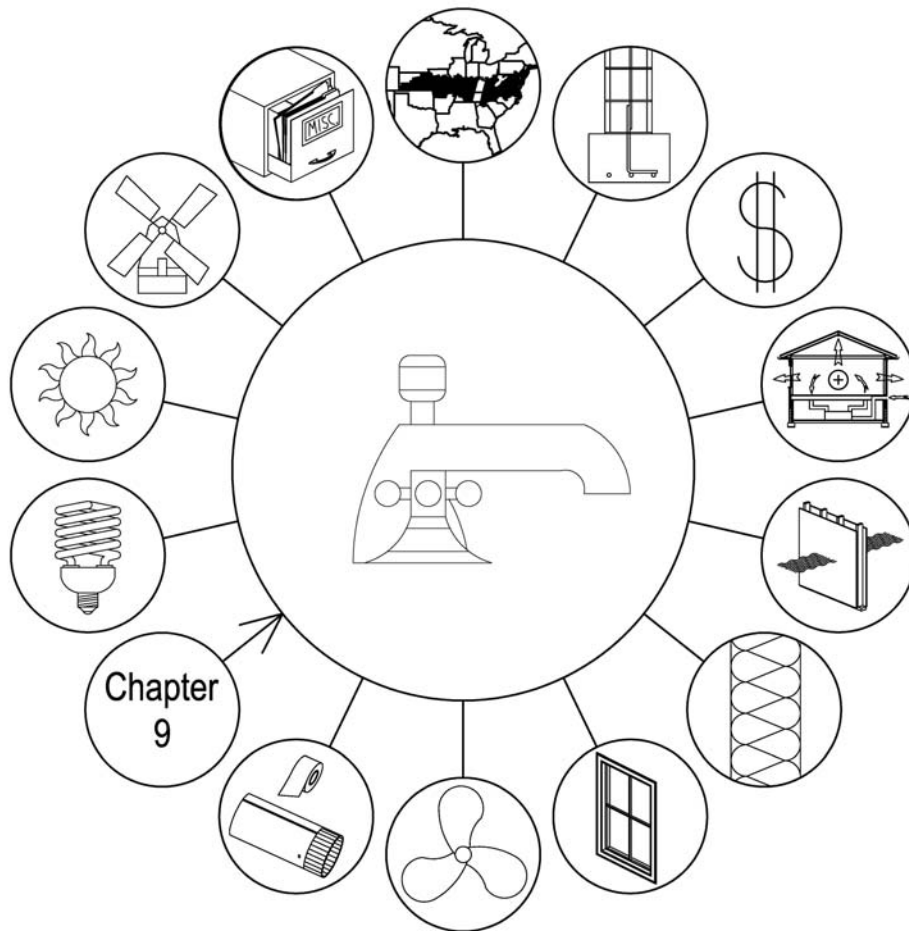



ENERGY CONSERVATION FOR WATER HEATING

No matter what type of energy source is used to heat water, be certain to take advantage of the savings from conservation measures:

- For new homes:
 - keep the length of the hot water pipe runs as short as possible. Careful planning can result in lengths of less than 30 feet.
 - consider a manifold plumbing system to reduce the size of hot water lines
- Use ENERGY STAR® appliances that reduce hot water requirements.
- Lower the temperature setting on the water heater to 120°F.
 - saves energy and provides plenty of hot water
 - reduces the risk of injury from scalding
 - if hotter temperatures are needed for dishwashing, select dishwashers with booster heaters
- Wrap the outside of the water heater tank with an insulation jacket, Figure 9-1.
 - simple to install—payback is less than 1 year
 - do not cover the relief or drain valve
 - for gas water heaters, do not block the air inlet to the burner or the flue vent on the top
- Insulate first four feet of all pipes connected to unit.
- Use low-flow showerheads that deliver water at 1.5 gallons per minute maximum. Well-designed fixtures deliver water at that rate and still provide plenty of force.
- Install heat traps. These will keep hot water from circulating freely out of the water heater.
- Install low-flow aerators on sink and lavatory faucets.
 - save on energy bills
 - kitchen sink may need a higher volume flow faucet for filling pots and pans more quickly
- Using the tank drain at the bottom of the tank, drain approximately one quart from the tank every 3 months (or as recommended by the manufacturer). This removes the sediment from the tank and increases the heating efficiency.

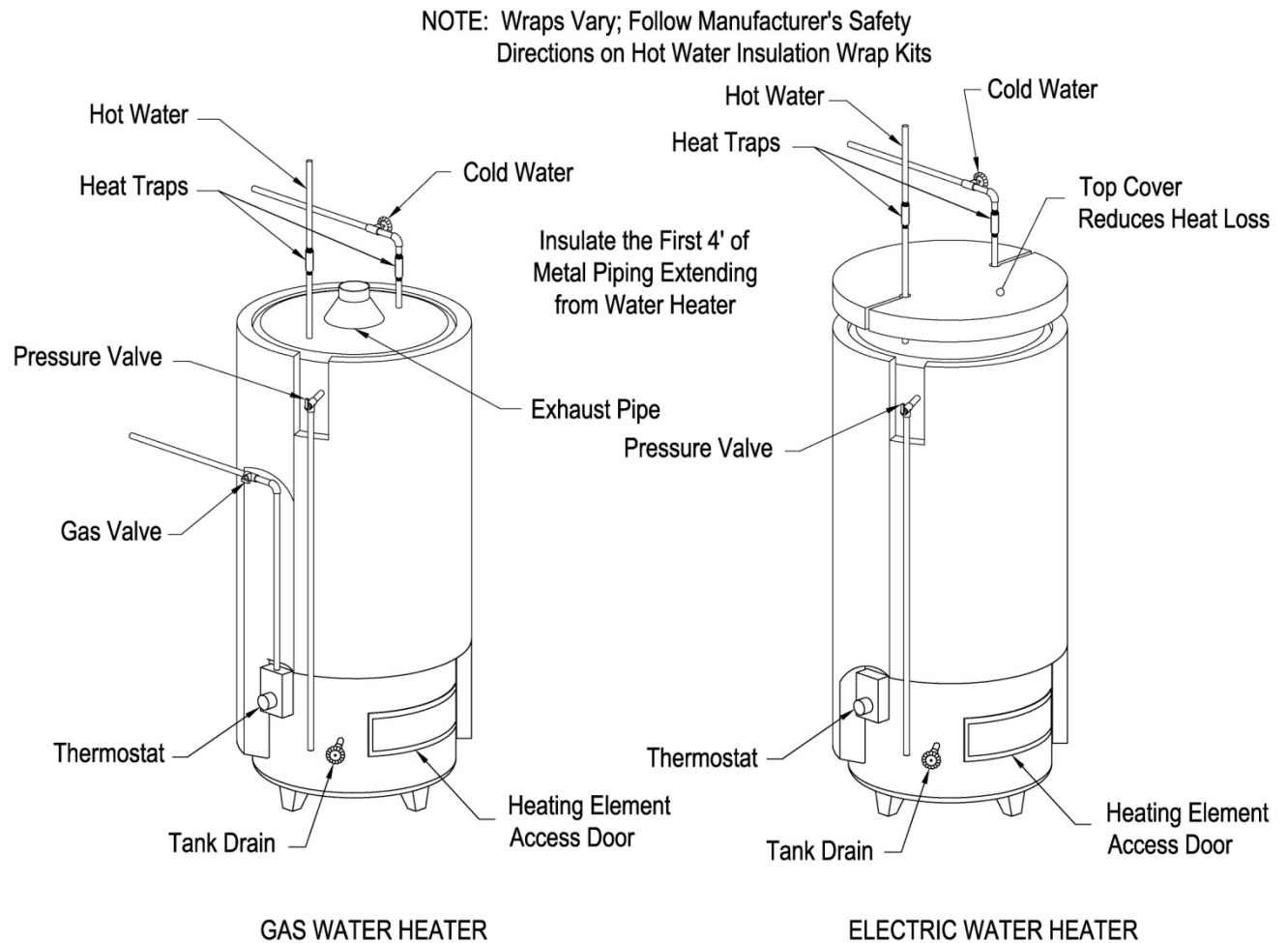

Figure 9 – 1 Insulating Jacket for both Gas and Electric Water Heaters

GAS WATER HEATERS

ENERGY STAR® gas water heaters will have energy factors over 0.62 when these ratings go into effect (see Table 9-1).

In addition to variations in insulation, gas water heater efficiency is also affected by burner design, the shape of the flue baffles that slow the hot exhaust gases down to increase heat transfer to the water, and the amount of surface area between the flue gases and the water.



Table 9-1 Energy Factors (EF) for ENERGY STAR® Gas Water Heaters

Type	Energy Factor
Gas Storage (ending 8/31/2010)	≥ 0.62
Gas Storage (beginning 9/1/2010)	≥ 0.67
Whole-home Gas Tankless	≥ 0.82
Gas Condensing Storage	≥ 0.90

Fuel-fired water heaters, located in a conditioned space, must be in a sealed mechanical room with fresh air inlets. To avoid the need for a sealed mechanical room, another option would be to use a fuel-fired water heater that includes provisions for outside combustion air, such as a direct-vent unit. These have a double flue pipe that includes both an intake for combustion air and a flue for exhaust gases.

Higher efficiency gas water heaters have blowers for venting and delivery of combustion air and more sophisticated energy features, such as electronic ignition, flue dampers, and condensing heat exchangers. These high efficiency gas water heaters can achieve energy factors over 0.90.

ELECTRIC WATER HEATERS

For electric water heaters, higher efficiency units have energy factors up to 0.97. Often, the additional cost of a high efficiency unit is quite low compared to the savings. ENERGY STAR® labeling for electric water heaters is not available because, beyond adding additional insulation to reduce standby losses, little can be done to improve efficiency. In general, electric hot water heaters are more expensive to operate than gas units; however, as energy prices change, this difference can be small. Because of the high cost of sealed combustion gas water heaters, some builders have elected to use electric water heaters, even though gas is available. A builder does this to avoid the need for a sealed, vented mechanical room.

HEAT RECOVERY UNITS

A heat recovery unit, also called a desuperheater, recovers excess heat from an air conditioner or heat pump to provide “free” hot water. The heat is captured from the refrigerant line between the outside condenser and the inside equipment (see description of how air conditioners work in Chapter 7). A heat exchanger mounted on this line extracts heat from the superheated, high pressure, refrigerant gas, which is hot enough to be able to lose some heat and still not begin to condense into a liquid.

During the summer, the desuperheater can usually provide 100% of the hot water needs of a family and improve the efficiency of the air conditioner or heat pump. In the spring and fall, with no heating or



cooling, the desuperheater is ineffective. In the winter, if connected to a heat pump, the desuperheater can still provide hot water more efficiently than a conventional electric water heater. The energy savings from a desuperheater connected to a central air conditioner depend on how often the air conditioner is used. Savings are typically 20% to 40% on annual water heating bills.

The size and efficiency of the water heater and cooling equipment will affect the performance of a desuperheater. Combining desuperheaters with new higher efficiency air conditioners or heat pumps, which have lower refrigerant temperatures, can reduce the energy savings. The HVAC system should be at least 2 tons in size to be used effectively with a desuperheater. Desuperheaters range in cost from \$550 to \$750 and save \$50 to \$180 annually. Before installing a unit, make sure it will not void warranties on mechanical equipment. Also, check on the water supply in the area to see if any buildup may occur in the desuperheater, reducing its effectiveness.

SOLAR WATER HEATERS

Solar water heaters use a unique method for heating water that requires that a knowledgeable person design the roof slope, orientation and total system. Solar water heaters must be installed and maintained by someone in that field. See Chapter 12 for more information. With the current cost of other forms of energy and tax incentives at the state and federal level, solar water heaters can be a cost effective option. They can also be oversized and used to assist with heating a home, providing two options for savings.

ON DEMAND WATER HEATERS

On demand water heaters use higher capacity electric coils or gas burners to heat cold water only when there is a need for hot water (see Figure 9-2). Electric units use a large amount of current and require special wiring. Electrical units also increase the demand on the local electrical system during the utilities' peak. Care should be used when considering them because of the potential for time-of-day or demand charges for electrical power in residences in the future.

These water heaters save energy in two ways: they have no storage tank so there is no need to keep stored water continuously warm, and gas-fired units usually heat water more efficiently than gas tank type water heaters. Conventional water heaters keep 30 to 50 gallons of water at a constant temperature, 24 hours a day.

On demand units must be sized carefully for their planned use. A small unit may provide heating for only one faucet or appliance at a time, so a higher capacity model or several units are generally needed to provide hot water for conventional residential uses. By eliminating the standby losses and by increasing efficiency, on demand water heaters may save 10% to 20% of a household's usual water heating bill.

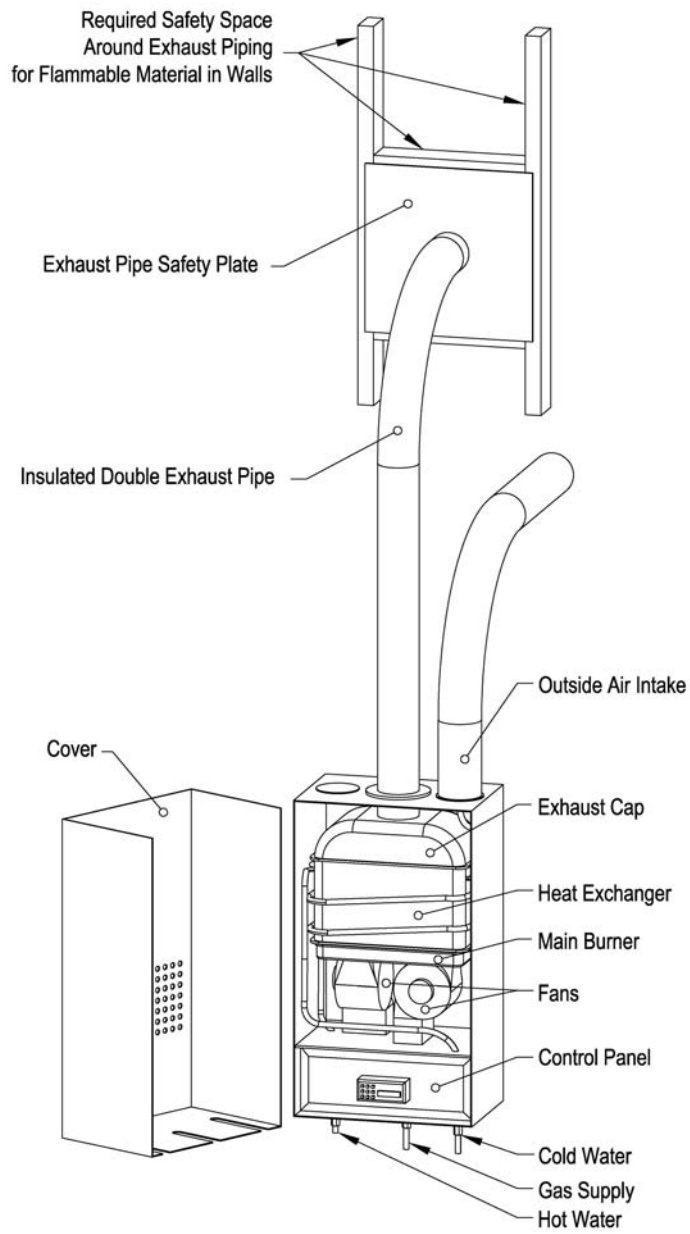
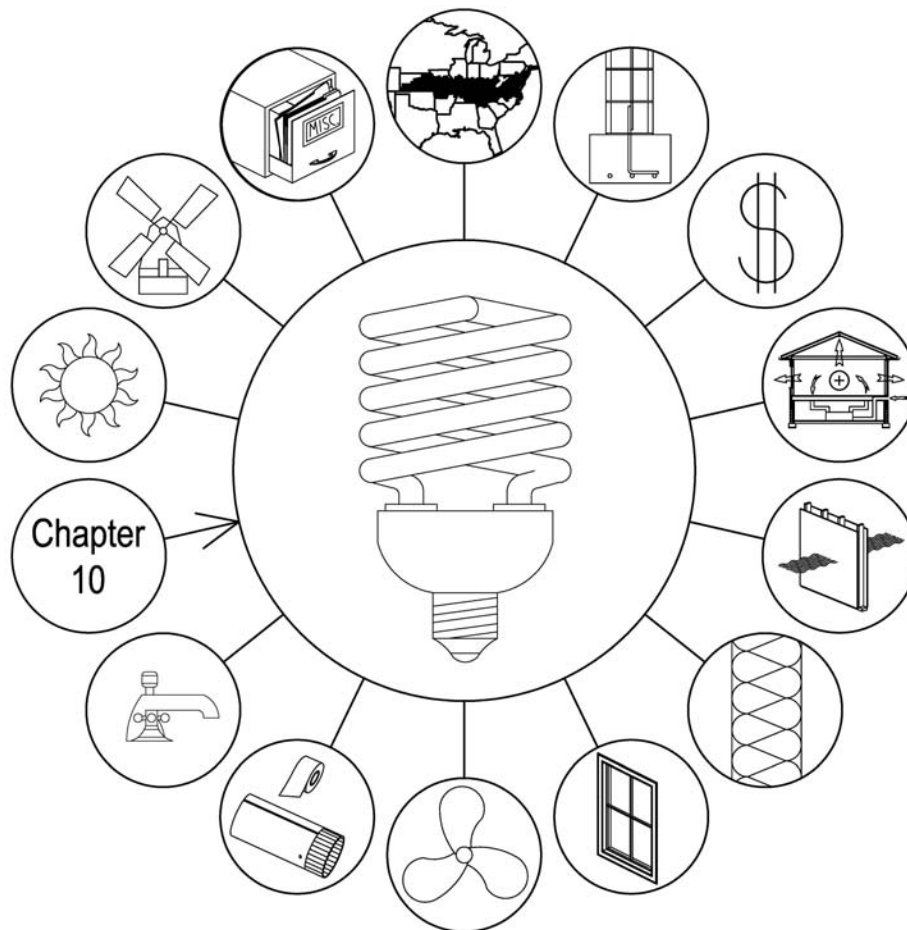

Figure 9 – 2 On Demand Tankless Water Heater (Gas)



CHAPTER 10: APPLIANCES AND LIGHTING

According to the U.S. Environmental Protection Agency, appliances and home electronics account for 20% of energy bills in the typical American home. By selecting energy efficient appliances and energy efficient lighting fixtures and lamps, a builder is able to provide value to the future homeowner. Actual costs will depend on the size and efficiency of the appliance, the price for local energy, plus the manner in which the new homeowner uses the appliance. These initial appliance and lighting selections can help guide future purchasing decisions of the homeowner, save money and reduce greenhouse gas emissions.





ENERGY EFFICIENT APPLIANCES

Heating, cooling, and hot water uses usually make up the biggest portion of energy needs in Kentucky homes. However, the cost of operating major appliances is significant. In the average home, energy bills range from \$200 to \$400 each year to run refrigerators and freezers, clothes washers and dryers, ranges and ovens, and other appliances.

While most new appliances offer a wide variety of features, many models are not designed to be energy efficient. When choosing appliances, it is important to consider their operating costs, which are the costs for the energy they require to run. In addition, consider the purchase price and the various features and conveniences that each appliance offers.

Appliances that operate efficiently may cost more to buy, but the energy savings they provide make them a good investment. For example, running a standard refrigerator over its life of 15 to 20 years costs about three times as much as its purchase price. An energy efficient model can save hundreds of dollars over the life of the appliance.

In addition to saving money on operating costs, energy efficient appliances give off less waste heat than standard models. Therefore, energy efficient appliances help keep rooms inside the house cooler during warm weather.

To compare the energy usage of one appliance to a competing appliance, use the bright yellow-and-black EnergyGuide label (see Figure 10-1). Federal law requires that manufacturers display this label on all new refrigerators, freezers, water heaters, dishwashers, clothes washers, and room air conditioners. Since 2007, labels must also be attached to central air conditioners, heat pumps, furnaces, boilers, pool heaters and certain light bulbs and plumbing products. Ceiling fans join this list in 2009. EnergyGuide labels are not currently required on kitchen ranges, microwave ovens, clothes dryers, demand-type water heaters, and portable space heaters.

The top, large number on the EnergyGuide label estimates how much that appliance model will cost to operate each year, based on an estimate of the amount of energy used and on 2007 national average energy costs. The dollar cost for a particular model is shown on a line scale that compares its energy cost with the models with the lowest and highest annual energy costs. Much like the federal miles per gallon ratings for automobiles, the actual amount of energy used and cost will vary according to local prices and each family's lifestyle.

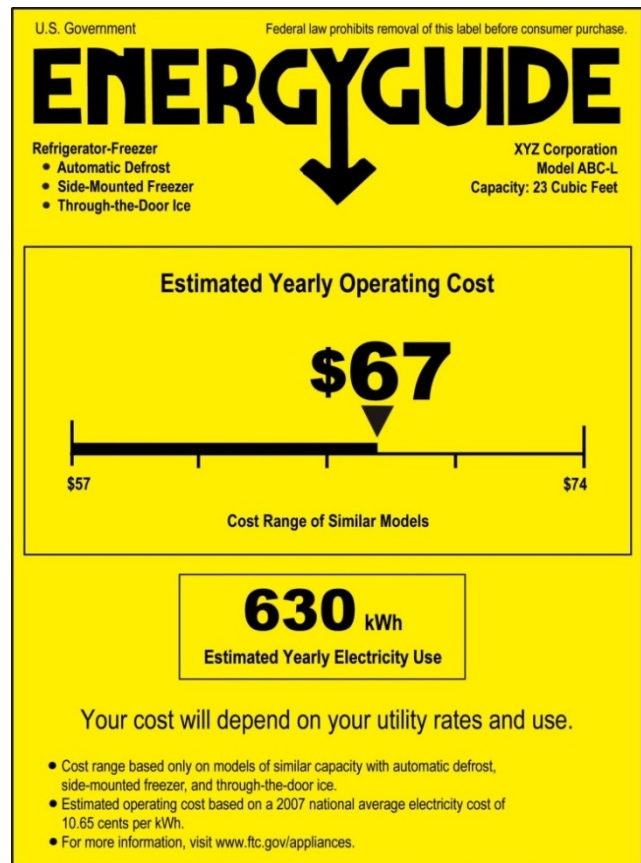

Figure 10 – 1 EnergyGuide Label



The EnergyGuide label also displays the appliance's energy consumption, such as the estimated yearly electricity use. To facilitate comparison, the label provides the name of the manufacturer, model number, type of appliance, and capacity. Use the exact energy rates from local utilities to more precisely estimate operating costs for the appliance.

ENERGY STAR® APPLIANCES

The U.S. Environmental Protection Agency (EPA) and Department of Energy (DOE), working with appliance manufacturers, have developed the ENERGY STAR® labeling system to indicate appliances that meet their criteria for energy efficiency. The ENERGY STAR® label, Figure 10-2, may be found on clothes washers, refrigerators, dishwashers, and room air conditioners. An appliance receives the ENERGY STAR® rating if it is significantly more energy efficient than the minimum government standards, as determined by standard testing procedures. The amount by which an appliance must exceed the minimum standards is different for each rated product and depends on available technology. ENERGY STAR® rated products are always among the most efficient available.



Figure 10 – 2 Energy Star Label

LIGHTING

Standard incandescent bulbs are the most common lighting sources for homes. However, incandescent lamps are quite inefficient. They convert only 10% of the electricity to lighting. The remainder produces waste heat. The lighting industry has responded to the need for energy efficiency with a wide range of excellent products. The most notable of these options are:

- Compact fluorescent lamps use thin tubes and reduce the energy use by 70% when compared to standard incandescent lamps.
- Lower wattage fluorescent tubes with electronic ballasts can reduce energy use by at least 30% when compared to standard fluorescent tubes.
- LED lighting is a rapidly evolving technology that produces light in a new way. It is already beginning to surpass the quality and efficiency of existing lighting technologies; however, because this is a new technology, care must be used in the selection of bulbs.
- High-pressure sodium and metal halide lamps, mainly intended for exterior use in residences, are four to six times more efficient than standard exterior lamps.

The most common measure of lighting efficiency is lumens/Watt; however, with the new types of products that might not be a useful figure. For example, if task lighting is required, LED lamps provide a more highly directional light source. When selecting residential lights, consideration must be given to the color rendition they provide. It is measured by the color rendition index (CRI) which compares a lamp's ability to render color similar to natural light.



There is great opportunity for originality and ingenuity in residential lighting design. A home combines more functions and needs than most other buildings, yet energy efficient lighting can be achieved at minimal cost. Of course, the needs of each home must be considered individually, but certain conservation measures are applicable to all home designs, including:

- Use motion or occupancy sensors to turn off lights in rooms not used.
- Energy efficient fixtures and lamps for areas of high continuous lighting use, such as the kitchen, sitting areas, and outside the home for safety and security;
- Local task lighting for specific activities such as working at a desk, on a kitchen counter, or in a workshop;
- Accent lighting so that the overall level of lighting in an area can be reduced;
- Timers and light-sensitive switches for exterior lighting;
- Use sunlight as the light source in areas normally occupied during the day; and
- Solid-state dimmers and multilevel switches for variable lighting levels.

The amount of light a lamp provides is measured in lumens. The electrical energy used to provide that light is measured in watts. The lighting level depends upon the efficiency of the light source in converting watts to lumens and the ability of the lighting fixture to distribute the light effectively. High efficiency lamps and lighting fixtures reduce wattage requirements but still provide desired lighting levels.

The efficiency—called the efficacy—of a lamp is measured in lumens of light produced per watt of electricity consumed. In designing a lighting plan, consult with knowledgeable professionals about optimum lighting levels and different types of fixtures and lamps. The sizing guidelines for fluorescent lighting systems are presented in Table 10-1.

Type of Room	Size of Room (sq ft)	Amount of Light Needed (watts)
Living room, Bedrooms, Family room or Recreation room	under 150	40 to 60
	150 to 250	60 to 80
	over 250	.33 watt/sq ft
Kitchen, Laundry, or Workshop	under 75	55 to 70
	75 to 120	60 to 80
	over 120	.75 watt/sq ft

When choosing lighting fixtures, consider the long term energy costs of the fixture as well as the purchase price. Energy efficient lighting alternatives reduce waste heat in summer, thereby saving money on cooling costs and increasing comfort levels. In addition, they typically last 9 to 10 times longer than standard incandescent lamps.

Table 10-2 shows the purchase and operating costs of a number of lighting options. The different alternatives are grouped by lumens, so lamps for similar uses can be compared.



Table 10-2 Standard Designs versus Energy Efficient Residential Lighting Designs

Room	Hr/Day	Standard Lighting Design			Energy Efficient Design			
		Type*	Watts	kWh/yr	Extra Cost (\$)	Type*	Watts	kWh/yr
Kitchen	8	I	150	438	30	F	60	175
Living	6	I	150	328	5	H	135	296
Dining	5	I	75	137	—	I	75	137
Bathrooms (2)	4	I	200	292	—	I	200	292
Hallway	10	I	150	545	30	F	60	219
Bedrooms (3)	4	I	225	328	30	F	90	131
Laundry	4	I	100	146	25	F	30	44
Closets (5)	1	I	300	110	—	I	300	110
Porch	12	I	100	438	15	F	30	131
Floodlight	12	I	360	1,577	100	HPS	150	657
Total Annual Electricity Use (kWh)				4,339	2,192			
Annual Lighting Cost (\$ @ \$.065/kWh)				\$282	\$142			
Annual Savings on Lighting Costs							\$140	
Simple Extra Cost for Energy Efficient Lighting							\$235	
Payback Period							1.6 years	
Rate of Return on Investment							60%	
*I = Incandescent; F = Fluorescent; H = Halogen; HPS = High Pressure Sodium								

ENERGY STAR® ADVANCED LIGHTING PACKAGE

The ENERGY STAR® Advanced Lighting Package (ALP) designation was developed by the EPA to identify homes equipped with a comprehensive set of ENERGY STAR® qualified light fixtures. The designation has been adopted by some Green Building Programs as a method of obtaining points toward certification. An Advanced Lighting Package for new home construction consists of a minimum of 60% ENERGY STAR® qualified hard-wired fixtures and 100% ENERGY STAR® qualified ceiling fans, wherever installed. ENERGY STAR® qualified hard-wired fixtures use CFLs where the bulb's attachment does not allow for replacement with an incandescent bulb, Figure 10-3.

The benefits of an Advanced Lighting Package are numerous. The homeowner will expect energy bill savings because the ALP uses about 75% less energy than standard models. When a builder incorporates the ALP into new construction, the homebuyer will experience improved quality because the Energy Star® qualified fixtures must meet strict EPA guidelines for both energy efficiency and quality. Choice and flexibility are great as the ALP requirements are designed to promote flexibility. Since the qualified lighting fixtures generate about 75% less heat than standard incandescent lighting, the homeowner will



be comfortable with a decrease in the home's cooling costs. Additional energy and money may be saved on diminished air conditioning costs by allowing higher thermostat settings. By lowering the overall household energy use, each home built with an ALP will help reduce greenhouse gas emissions and air pollutants.

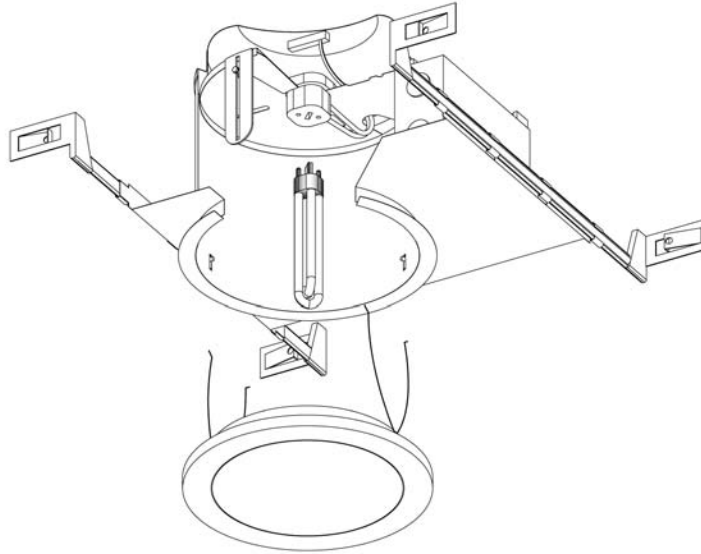

Figure 10 – 3 Recessed CFL Pinned Bulb

RECESSED LIGHTS

Recessed lighting is a popular method of providing room lighting; however, it creates a high potential for air leakage through the ceiling. To address that problem, lighting manufacturers have created recessed lighting that is labeled Air-Tight. The Air-Tight label can be used if the fixture does not allow more than 2 cfm air leakage at 75 Pascals. Recessed lights installed above the ceiling should be both air-tight and insulation contact, IC, rated. The Air-Tight designation can be achieved by either making the entire housing, the trim, or the housing air-tight, Figure 10-4.

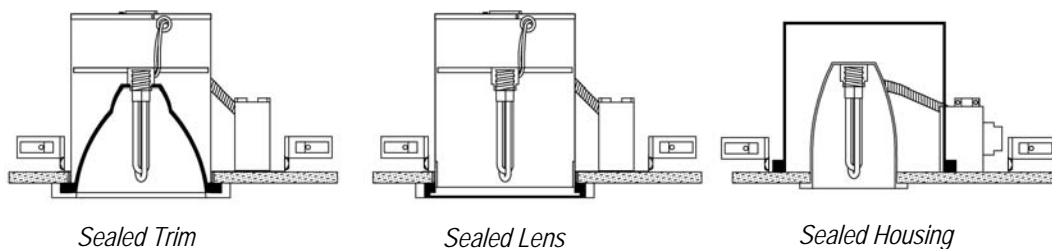

Figure 10 – 4 Air-Tight Recessed Lights



One method to avoid the air leakage problem is to place the recessed lights in the conditioned space, by installing them in a soffit that has an air-barrier between it and the unconditioned space, Figure 10-5.

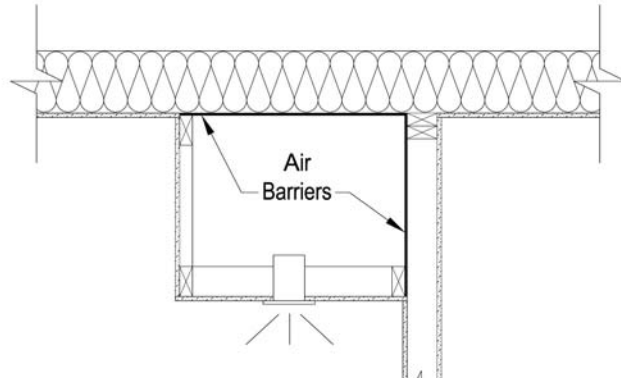

Figure 10 – 5 Soffit Air Seal

SOLAR TUBES

Solar tubes provide an option for providing daylighting in areas of the house with limited or no windows, Figure 10-6. Solar tubes carry the NFRC rating similar to windows and are available with lights and fans for use in bathrooms. Because they reduce the need for electricity, they are considered by some Green Building Programs as a method of obtaining points toward certification.

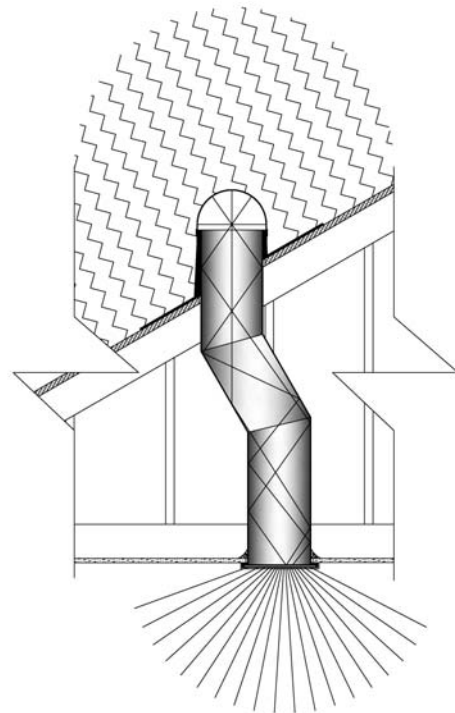

Figure 10 – 6 Solar Tube Light



CHAPTER 11: PASSIVE SOLAR HOMES

Passive solar homes capture both the beauty of the outside world and the heat coming in from the sun. They are designed with the local climate in mind—to use temperature, humidity, wind, and solar radiation to determine the site, orientation, floor plan, and overall building layout, and materials.

Current trends in housing, such as expansive glass areas, daylighting, sunrooms, great rooms, tile floors, fireplaces, and open floor plans fit well into passive solar designs. Effective designs will reduce heating and cooling bills and provide greater comfort.

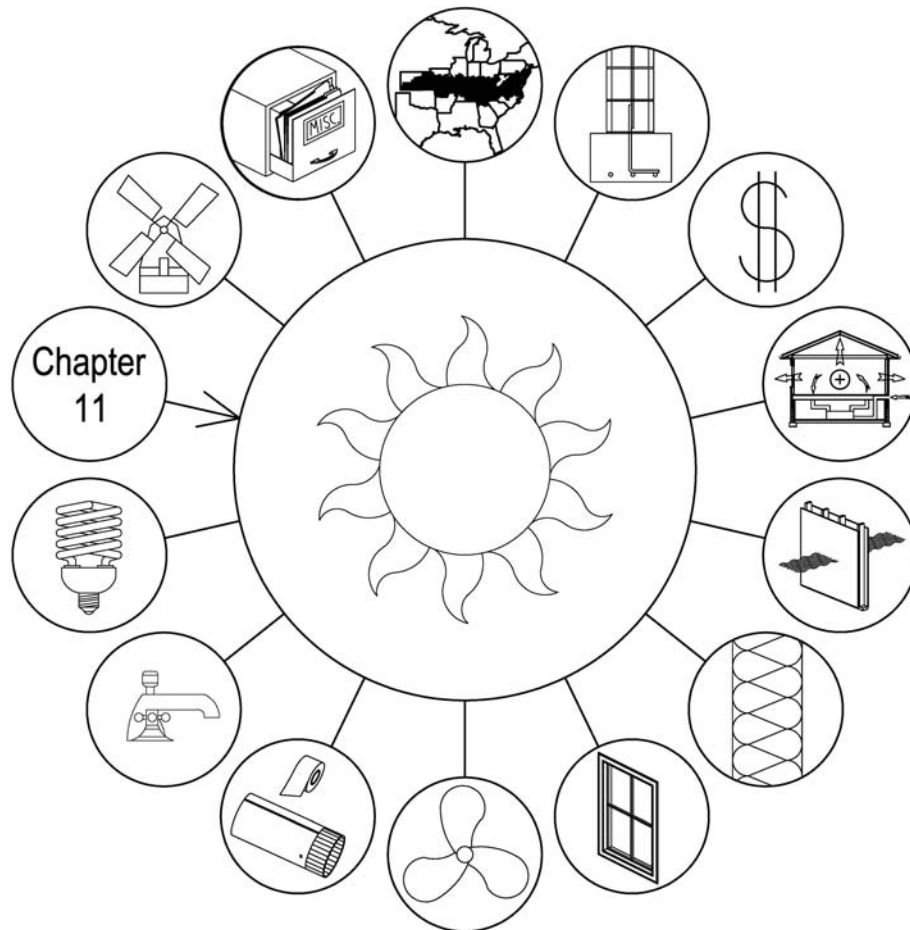



BASIC DESIGN GUIDELINES

A cardinal rule in passive solar design is to set one's sights properly—do not expect more than the sun can deliver. The Southeastern portion of the United States has cool, relatively cloudy winters and hot, humid, relatively sunny summers. Many well-designed passive solar homes in Climate Zone 4 provide their owners with low energy bills and year-round comfort, as well as natural daylight and visual connection with the outdoors. However, poorly designed passive solar homes may actually have uncomfortable temperature swings both in summer and in winter.

The key features of passive solar homes are:

- Energy conservation measures—energy efficiency is always the most cost effective way and should be the first step in designing any home, including a passive solar home. For guidance, use details from a comprehensive energy package, as described in Chapter 2.
- Glass concentrated on the south—south windows let sunlight into the building in winter and can be shaded in summer. Low-emissivity coatings will reduce heat loss at night and heat gain in summer.
- Window shading—overhangs, blinds, shade screens, curtains, and landscaping shade unwanted sunlight in summer.
- Thermal storage mass—tile-covered slab floors, masonry walls, and water-filled containers store solar heat and save energy all year.
- Ventilation—natural breezes, ceiling fans, whole house fans, and space fans can provide comfort during warmer weather.

Whether considering how to include passive solar features in a new home by adapting a conventional home plan or designing an entirely new plan, the following design ideas should be considered. Rooms with large expanses of glass should include thermal storage mass.

- Day-use rooms—Breakfast rooms, sunrooms, and playrooms work well on the south side of the house. They should adjoin rooms that are used frequently to take full advantage of solar heating.
- Frequently used rooms (morning to bedtime)—Family rooms, kitchens, dens, and dining rooms work well on the south side. Be conscious of potential problems with glare from sunlight through large expanses of windows, Figure 11-1.
- Sunspaces—Passive solar rooms can be isolated from the house. In winter, the doors or windows between the house and the sunspace can be opened to let solar heat move into the home. At night, the doors can be closed, and the sunspace buffers the home against the cold night air. In summer, sunspaces protect the home from outside heat gain—for best performance, they should not be air-conditioned.
- Privacy rooms—Bathrooms and dressing rooms can be connected to solar-heated areas, but are not usually located on the south side since large windows are not desirable.
- Night-use rooms—Bedrooms are usually best on the north side, unless used often during the day (such as a study or children's bedroom). It is often difficult to fit thermal storage mass into bedrooms, and privacy needs may limit opportunities for installing large glass areas. However, some household members may prefer bedrooms filled with natural light that can use passive solar features effectively.
- Seldom used rooms—Formal living rooms, dining rooms, and extra bedrooms are best on the north side, out of the traffic pattern and air flow.
- Buffer rooms—Unheated spaces such as closets, laundries, workshops, pantries, and garages work best against the north, east, or west exterior walls to protect the conditioned space from outside temperature extremes.
- Exterior covered areas—Porches and carports on the east and west provide summer shading. However, west-facing porches may be uncomfortable in the afternoon. Avoid porches on the south



side, as they shade winter sunlight. South-facing decks on a second floor often shade windows on the first floor; they should only be three to four feet wide to allow winter sunlight access to the windows below.

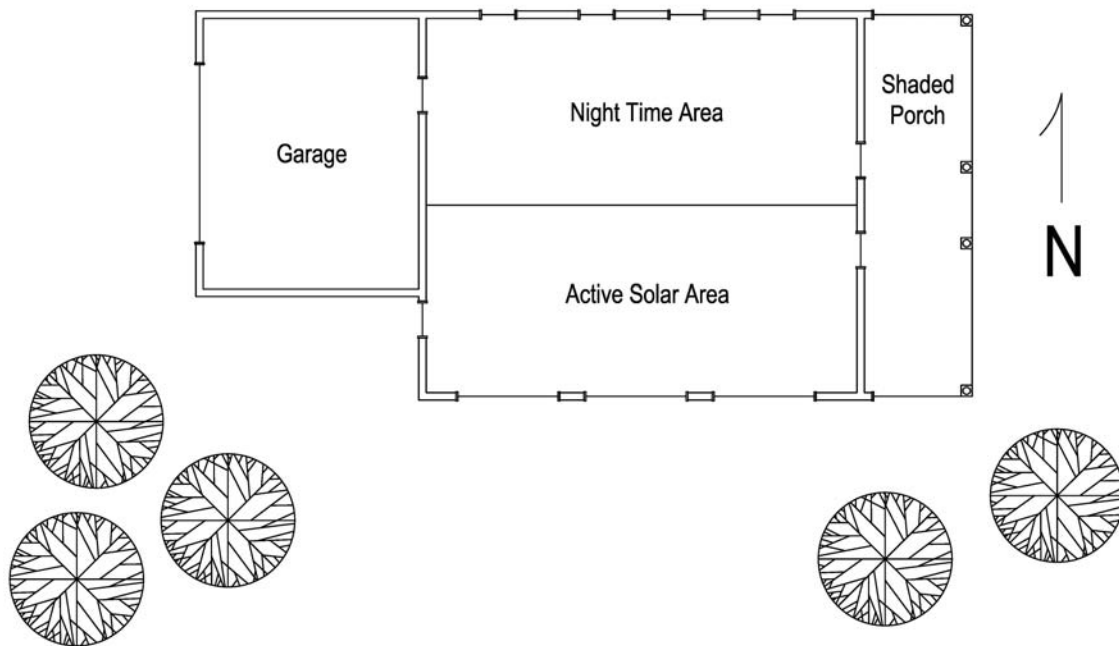

Figure 11 – 1 Passive Solar Room Planning



PASSIVE SOLAR COMPONENTS

The most successful passive solar homes are simple. They combine energy conservation features, direct gain windows and sunspaces, adequate thermal storage mass in direct sunlight, open floor plans to promote natural convection of solar heat throughout the house, and effective natural cooling techniques. Although the design elements are basic, the specifications for each component are critical. Too much south-facing glazing, inadequate thermal mass, an unbalanced floor plan, and lack of shading and ventilation can create an energy loser—not a winner.

PASSIVE SOLAR WINDOWS

At a minimum, passive solar windows should be double-glazed and face within 20 degrees of due south. Avoid roof glass or skylights, as well as east and west windows, which cause overheating in summer and suffer heat loss at night during the winter. North windows are helpful for ventilation, daylight, aesthetics, and code requirements for emergency exits.

Low-emissivity windows will improve the performance of passive solar homes. Although they screen sunlight during the day, they reduce nighttime heat loss and improve comfort substantially. If a home has large areas of south glass, but little thermal storage mass, low-e glazing is highly recommended to help moderate temperature extremes. The savings provided by low-e glass can be as great in summer as in winter, depending on the window design and the home's location.

The SHGC is as important, if not more so, when looking at passive applications. This adds another level of complexity to the design of a passive solar house that requires a complete analysis.

PROPER DESIGN

The best passive solar homes combine energy conservation features, passive solar heating, and natural cooling. Table 11-1 shows examples of different combinations. Note that just adding more glass on the south side of a home, even with added mass, may not reduce annual energy bills due to higher summer cooling demands from the increased south window area.



Table 11-1 Energy Bills in Direct Gain Homes

	Area (sq ft)		R-values				Annual Energy Bills* (\$/yr)		
	South Glass	Concrete Slab	Ceiling	Wall	Floor	Windows	Heating	Cooling	Total
<i>Double-glazed Windows</i>									
Base Home	75	0	30	15	13	1.8	212	231	443
Example 1	180	720	30	15	13	1.8	147	192	339
Example 2	270	1,080	30	15	13	1.8	127	210	337
Example 3	360	1,440	30	15	13	1.8	108	229	337
<i>Low-e Windows</i>									
Base Home	75	0	30	15	13	3.3**	165	210	375
Example 1	180	720	30	15	13	3.3**	114	176	290
Example 2	270	1,080	30	15	13	3.3**	99	185	284
Example 3	360	1,440	30	15	13	3.3**	84	194	278

*For a 2,000 sq ft home in Lexington, KY modeled using CALPAS 3.

**Low-e glass on south windows only; others have double glazing.

Table 11-2 shows the savings from passive solar sunspaces. These rooms serve as practical, aesthetic buffers between outside temperature extremes and the interior rooms. In winter, the heat generated in a sunspace from incoming sunlight can significantly reduce heating bills.

Table 11-2 Energy Bills in Homes with Sunspaces

	Area (sq ft)		R-values				Annual Energy Bills* (\$/yr)		
	South Glass	Concrete Slab	Ceiling	Wall	Floor	Windows	Heating	Cooling	Total
<i>With Sunspace, Low-e Windows</i>									
Example 1	180	720	30	15	13	3.3**	157	114	271
Example 2	270	1,080	30	15	13	3.3**	141	125	266
Example 3	360	1,440	30	15	13	3.3**	127	137	264
<i>With Sunspace, Better House Insulation</i>									
Example 1	180	720	38	22	19	3.3***	80	112	192
Example 2	270	1,080	38	22	19	3.3***	55	123	178
Example 3	360	1,440	38	22	19	3.3***	39	136	175

*For a 2,000 sq ft home in Lexington, KY modeled using CALPAS 3.

**Low-e glass on south windows only; others have double glazing.

***Low-e glass on all windows.



THERMAL STORAGE MASS

Thermal storage mass improves the energy performance of a home throughout the year by keeping interior temperatures from fluctuating greatly. The presence of thermal mass distinguishes a passive solar home from a sun-tempered design that has moderate amounts of glass but no mass. Careful planning should adequately match the amount of mass with the glass exposure.

Four basic passive solar designs are:

- Direct Gain
- Passive Solar Sunspace
- Thermal Storage Wall
- Solar Air Collector

With a *Direct Gain* solar design, the south-facing windows allow sunlight directly into the living area, where a thermal storage mass captures the sun's energy (Figure 11-2). This heat is released back into the room later in the day (or night) after the sun goes down.

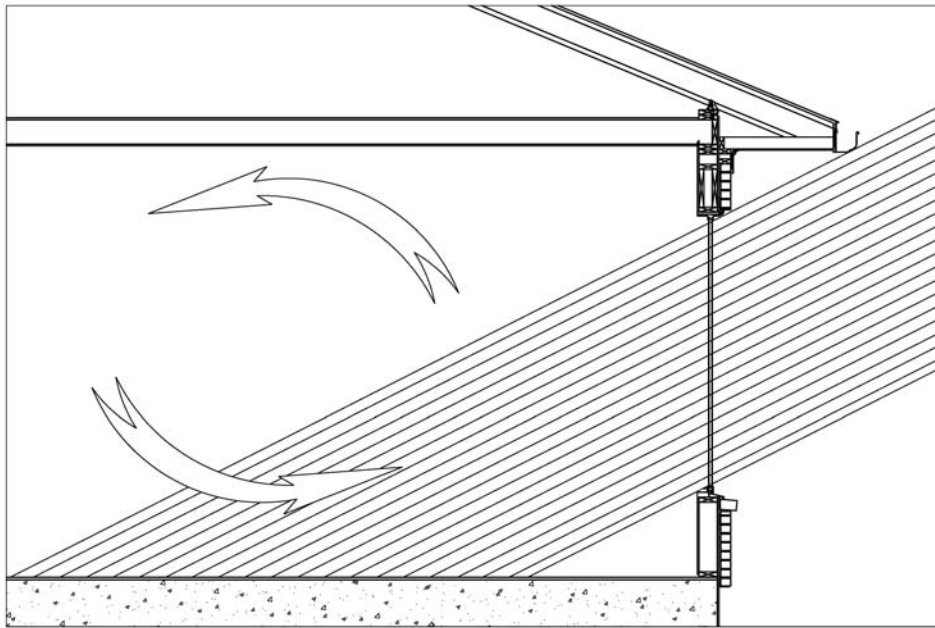

Figure 11 – 2 Basic Passive Solar Design: Direct Gain



Passive Solar Sunspace designs utilize a space called a sunspace, which is a room that is independent of the home's heating and cooling system. The sunspace captures the sun's energy and transfers the heat generated to the house (Figure 11-3).

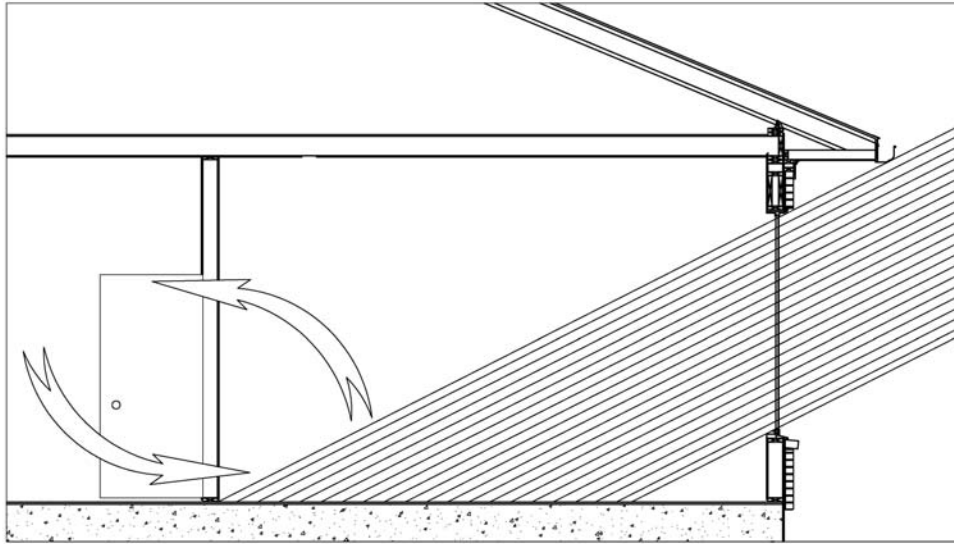

Figure 11 – 3 Basic Passive Solar Design: Passive Solar Sunspace

Thermal Storage Walls (Figure 11-4) store incoming solar heat and let it radiate into the living area.

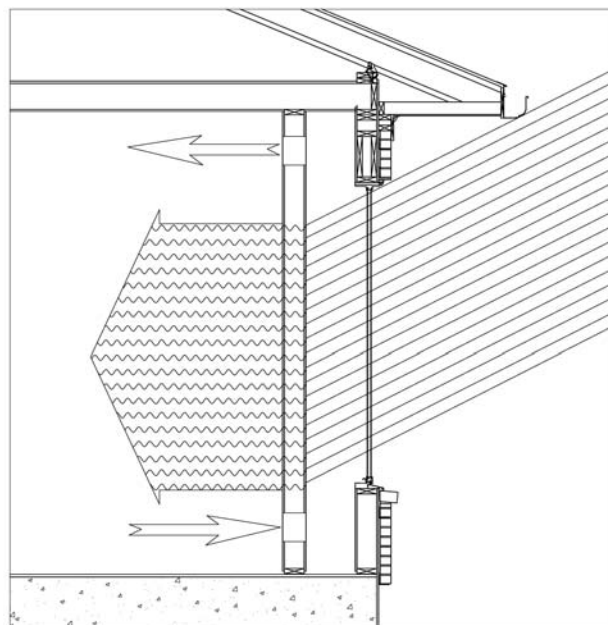

Figure 11 – 4 Basic Passive Solar Design: Thermal Storage Wall



Solar Air Collectors absorb incoming solar energy and then vent this energy through the back of the air collector. The solar-heated air is then transferred into the house (Figure 11-5).

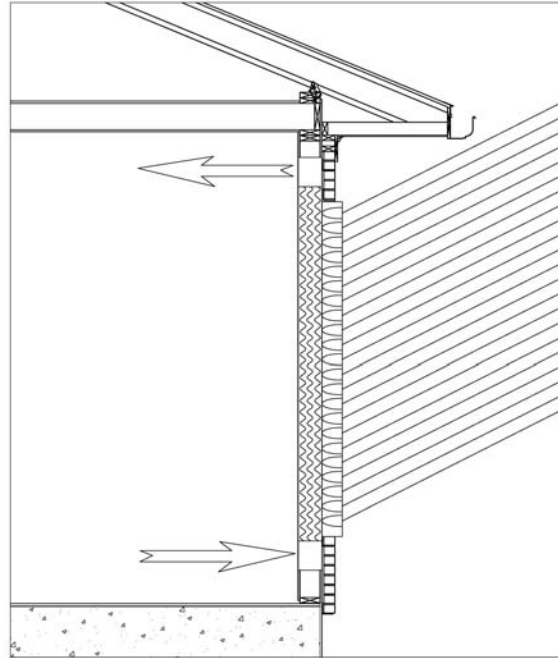

Figure 11 – 5 Basic Passive Solar Design: Solar Air Collector

PROBLEMS WITHOUT THERMAL STORAGE MASS

A home with large expanses of south-facing windows and little thermal mass has problems such as:

- Uncomfortably warm temperatures on sunny winter days when sunlight enters the home and heats the lightweight materials, which cannot store much of the heat.
- Uncomfortably cool temperatures on winter nights because they have little capacity to store heat, and the expansive windows lose substantial heat.
- High midday temperatures in summer; thermal storage mass helps to reduce peak interior temperatures during hot weather outside.
- Higher heating and cooling bills than comparable homes without as much glass area.

Properly designed passive solar homes should not overheat significantly during the day, and the heat they store helps to maintain temperatures above 60°F on most winter nights. One misconception about passive solar homes is that they retain high temperatures (above 68°F) for long periods. On nights, when outside temperatures drop below 40°F, passive homes may drop below 65°F and need backup heating. However, they will require less heating than a conventional home.

Providing adequate thermal mass is usually the greatest challenge to the passive solar designer. The amount of mass needed is determined by the area of south-facing glazing and the location of the mass. Follow these guidelines to ensure an effective design.



GUIDELINE 1: LOCATE THE THERMAL MASS IN DIRECT SUNLIGHT

Thermal mass installed where the sun can reach it directly is more effective than indirect mass placed where the sun's rays do not penetrate. Houses that rely on indirect storage need three to four times more thermal mass than those using direct storage.

GUIDELINE 2: DISTRIBUTE THE THERMAL MASS

Passive solar homes work better if the thermal mass is relatively thin and spread over a wide area (Figure 11-6). The surface area of the thermal mass should be at least 3 times, and preferably 6 times, greater than the area of the south windows. Slab floors that are 3 to 4 inches thick are more cost effective and work better than floors 6 to 12 inches thick.

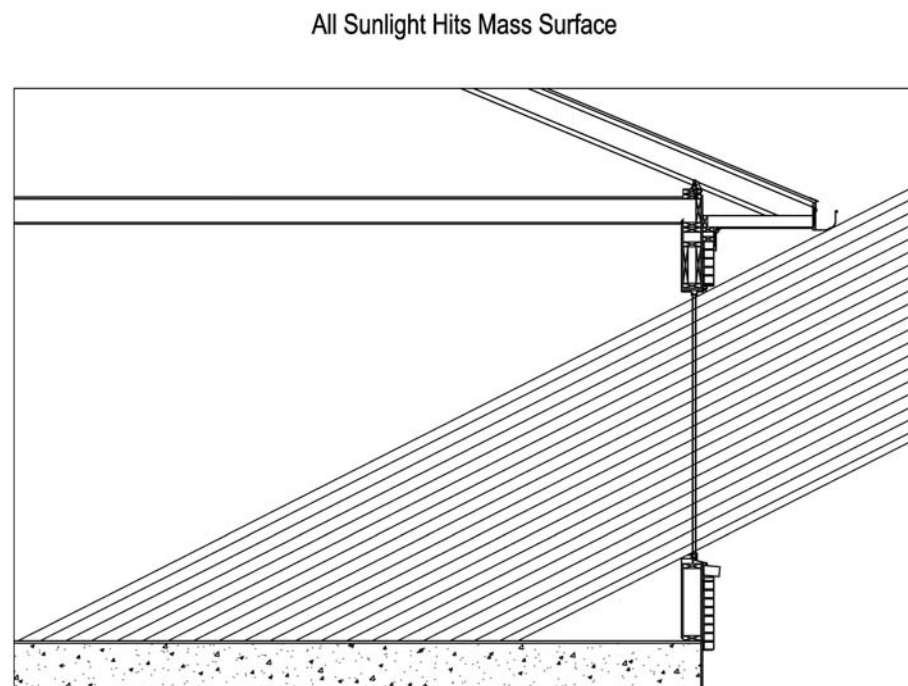

Figure 11 – 6 Spread Out Thermal Mass Surface

GUIDELINE 3: DO NOT COVER THE THERMAL MASS

Various floor coverings, such as carpet, vinyl or no covering at all, will affect the performance of passive solar homes with slab floors. Carpeting virtually eliminates savings from the passive solar elements. The intensity of the color of the floor covering also influences the amount of stored sunlight.

Masonry walls can have drywall finishes, but should not be covered by large wall hangings or lightweight paneling. The drywall should be attached directly to the mass wall, not to purlins fastened to the wall that create an undesirable insulating airspace between the drywall and the mass.



GUIDELINE 4: SELECT AN APPROPRIATE MASS COLOR

For best performance, finish mass floors with a dark color. Medium colors, which absorb 70% as much solar heat as a dark colors, are appropriate for many interior designs. A matte finish for the floor will reduce reflected sunlight, thus increasing the amount of heat captured by the mass and having the additional advantage of reducing glare. The color of interior mass walls does not significantly affect passive solar performance.

GUIDELINE 5: INSULATE THE THERMAL MASS SURFACES

Chapter 5, on insulation, shows techniques for insulating slab floors and masonry exterior walls. These measures should be followed to achieve the predicted energy savings.

GUIDELINE 6: MAKE THERMAL MASS MULTIPURPOSE

To ensure their cost effectiveness, thermal mass elements should serve other purposes. Masonry thermal storage walls are one example of a passive solar design that is often cost prohibitive because the mass wall is only needed as thermal mass. On the other hand, tile-covered slab floors store heat, serve as structural elements, and provide a finished floor surface. Masonry interior walls provide structural support, divide rooms, and store heat.

THERMAL MASS PATTERNS

Table 11-3 shows how the amount of thermal mass directly affects the savings produced by a passive solar home. Note that energy bills for a direct gain home with no thermal mass actually increase over a comparable energy efficient home with standard glass areas. Adding more thermal mass than is recommended increases energy savings but is often not cost effective.

Amount of Thermal Mass	Heating Energy Use (Million Btu/yr)	Energy Savings* (\$/yr)	30-Year Discounted Savings(\$)**
No thermal storage mass	44.3	0	0
¼-recommended mass	31.5	128	2,300
½-recommended mass	29.2	151	2,720
Recommended mass	28.0	163	2,935
1½ recommended mass	24.5	198	3,565

*For a 2,000 sq ft energy efficient home with 270 sq ft of south-facing windows.
 **The 30-year discounted energy savings is the sum of the savings for each year discounted to the present.

Thermal mass can be incorporated into a passive solar room in many ways, from tile-covered floors to water-filled drums. Consider the aesthetics, costs, and energy performance of the thermal mass material throughout the selection process.



DESIGN OPTIONS FOR THERMAL MASS

- Slab-on-grade floors—used in most passive solar homes. Slab floors can be finished with tile, stone, or brick finish; can be stained, or can be scored into a tile-like pattern. They can be expensive to install on upper floors. Floors made of brick, brick pavers, or thick tile also may be used.
- Exterior mass walls—walls composed of solid concrete, brick or stone and located on exterior walls. They must be exposed on the inside to sunlight and indoor air and insulated on the exterior. They should not be covered with materials such as wood paneling or fabric that will block the flow of heat between the wall and the room. A mass wall can be covered with drywall if it is bonded directly to the masonry surface without creating an airspace.
- Interior mass walls—solid mass walls between interior rooms. Since they have living area on both sides, they can be up to 12 inches thick, although thinner 4- to 8-inch walls deliver heat to rooms adjacent to the passive solar areas more quickly. Masonry fireplaces that are several feet thick store heat but are much less effective than thinner mass walls with greater surface area. Since masonry is not a good insulator, keep fireplaces on interior walls.
- Water-filled containers—water stores heat twice as effectively as masonry on a volume basis and five times as effectively on a weight basis. However, water containers look unusual in most living areas. Since they store more heat per pound, less weight is required to store the same amount of solar heat; therefore, they are easier to use in upstairs rooms. Commonly used water containers include aquariums, fiberglass cylinders (containers 8 feet high by 1 foot in diameter hold 47 gallons) and 30- or 55-gallon metal drums. Metal containers should be treated with a rust inhibitor to extend their life.
- Hot tubs, saunas, and indoor pools—some homeowners have tried to use hot tubs, saunas, and indoor pools as thermal storage mass. In most cases, these forms of water storage do not work well. In addition, the desired water temperature for comfortable use of these amenities is hotter than the passive solar contribution can possibly achieve. The water evaporating from these units must be controlled in summertime to avoid excess humidity.
- Thermal storage walls—a solid masonry wall fronted by exterior double-glazed windows. Sometimes known as Tromb  walls, these designs are one of the least cost-effective passive solar options. They are expensive to build, and many researchers question whether the mass wall has sufficient time to warm between the periodic spells of cloudy weather experienced by most of the Southeast United States in the winter.
- Phase change materials (PCM)—offer four to five times the storage capacity of water and 25 times that of masonry. PCMs store some heat as they increase in temperature, but most of their heat is stored when they change phases (melt). Each pound of phase change material absorbs as much heat when melting as 5 pounds of water does when increasing in temperature from 70°F to 90°F. The energy stored by the phase change is given up when the air in the room begins to cool and the phase change material solidifies. While potentially effective, PCMs are expensive and not readily available.

HEAT DISTRIBUTION

It may be necessary to transfer solar-heated air from the south-facing rooms in a passive solar home to other rooms. Passive solar heating is simple in its operation. Any design to distribute the heat throughout the house should reflect this simplicity.

As air is warmed by the sun on the south side of the building, it rises, causing cooler air from the interior of the house to circulate to the south side. This process is known as natural convection.



Floor plans that have the south-facing rooms stepped down from the north side enhance convection. A stepped design also allows rooms on the south to be constructed with slab floors and rooms on the north to have framed floors.

Sunspace designs that have large glazing areas may generate sufficient heat to warrant a small blower or fan to transfer the heat into the rest of the house. A ceiling fan can be used at a low setting or a thermostatically controlled blower can be installed in the connecting wall. These forced ventilation measures may also improve heat distribution for direct gain designs. The key to moving air heated by a passive solar design is to move it slowly; fast moving air, at less than 90°F, makes people feel uncomfortable.

ESTIMATING PASSIVE SOLAR SAVING

The following rules of thumb approximate the annual heating energy savings of passive solar homes:

- Each square foot of double-glazed south-facing window that is unshaded in the winter will save 40,000 to 60,000 Btu per year on a home's heating bill, if sufficient thermal mass exists.
- Low-emissivity glass will increase the savings 15 to 30 percent.

Thus, an energy efficient home with 200 square feet of passive solar windows and sufficient thermal storage mass could save 8 to 12 million Btu of energy on home heating bills each year. Movable insulation or low-e glass would save an additional 2 to 4 million Btu.

The cost of space heating with a standard heat pump or gas furnace in Kentucky is about \$10 per million Btu. Thus, the passive solar home described above could save as much as \$160 per year on heating bills with low-e windows.

DESIGN FOR SUMMER AND WINTER

When considering passive solar heating, do not forget the cooling season. Some passive solar homes in Kentucky have had overheating problems. Careful designs avoid overheating and often save on summer cooling bills. Chapter 6, on windows and doors, describes shading and ventilation measures.

Always remember that the south window area is only one component of an effective passive solar design. Thermal storage mass and summer overheating protection are critical as well.



CHAPTER 12: ALTERNATIVE TECHNOLOGIES

It takes a higher investment of time, money, and energy to extract, refine, and deliver our various fossil fuel energy resources today than it did 50 years ago. Much research and development is being done in the area of developing alternative technologies, especially those technologies using renewable energy resources. Energy efficient home building, which incorporates these alternative technologies, seeks to provide savings for today's homeowners, and may also provide enhanced energy security and prosperity for future generations.

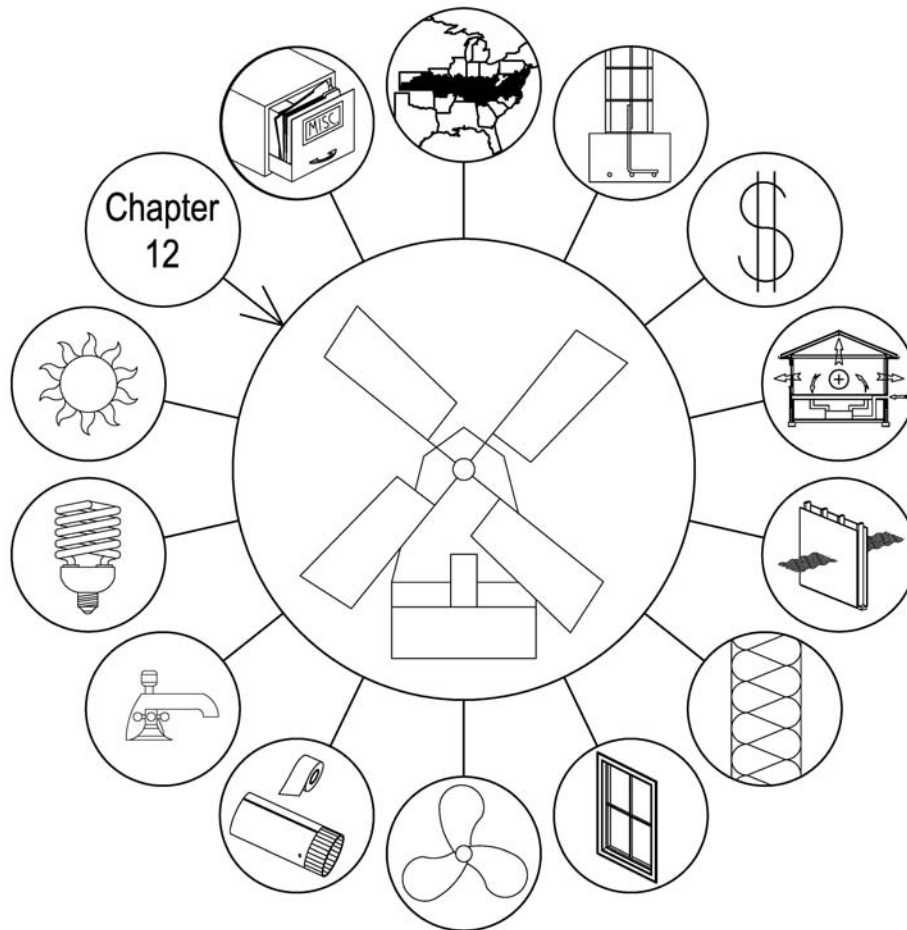



SOLAR HOT WATER

The incorporation of a domestic solar hot water system into residential homes has become increasingly popular over the last several years. The basic concept of all solar hot water systems is to use the sun's energy to heat or preheat water, thereby reducing the gas or electric requirements to produce hot water.

In general, all solar hot water systems have a solar collector (to collect the sun's energy), and a storage tank (to store the hot water). From this, the systems can be separated into two different categories, active and passive systems.

ACTIVE SYSTEMS

Active systems rely on pumps and valves to circulate the water or heat exchange fluid through the solar collector, while passive systems rely on the natural tendency of water to rise when heated, and thereby circulate through the system.

While active systems are slightly more complicated than passive systems, they can be more flexible in terms of the placement of the components since the location of the storage tank is not dependent on the physics of hot water buoyancy. On the other hand, passive systems, because of the lack of pumps, have been argued to be more durable and less prone to problems.

With direct systems, the domestic potable water is circulated directly through the solar collector. The pump circulates the water from the storage tank through the solar collector when the temperature of the solar collector is greater than that of the tank. Direct systems are not recommended for climates where the exterior temperature drops below freezing or for areas that have hard or acidic water.

For areas where freeze protection of the system is important, the recommended systems would either be an indirect (closed loop) or drain back system (see Figure 12-1). The indirect (closed loop) systems use a propylene glycol heat exchange fluid in the solar collector. The low freezing temperature of the propylene glycol provides the freeze protection for the system, allowing the solar systems to be used in climates prone to longer freezing times. These indirect systems require a check valve to prevent reverse thermosiphoning at night, since the hot water in the tank could convect heat back up to the typically roof mounted solar panels.

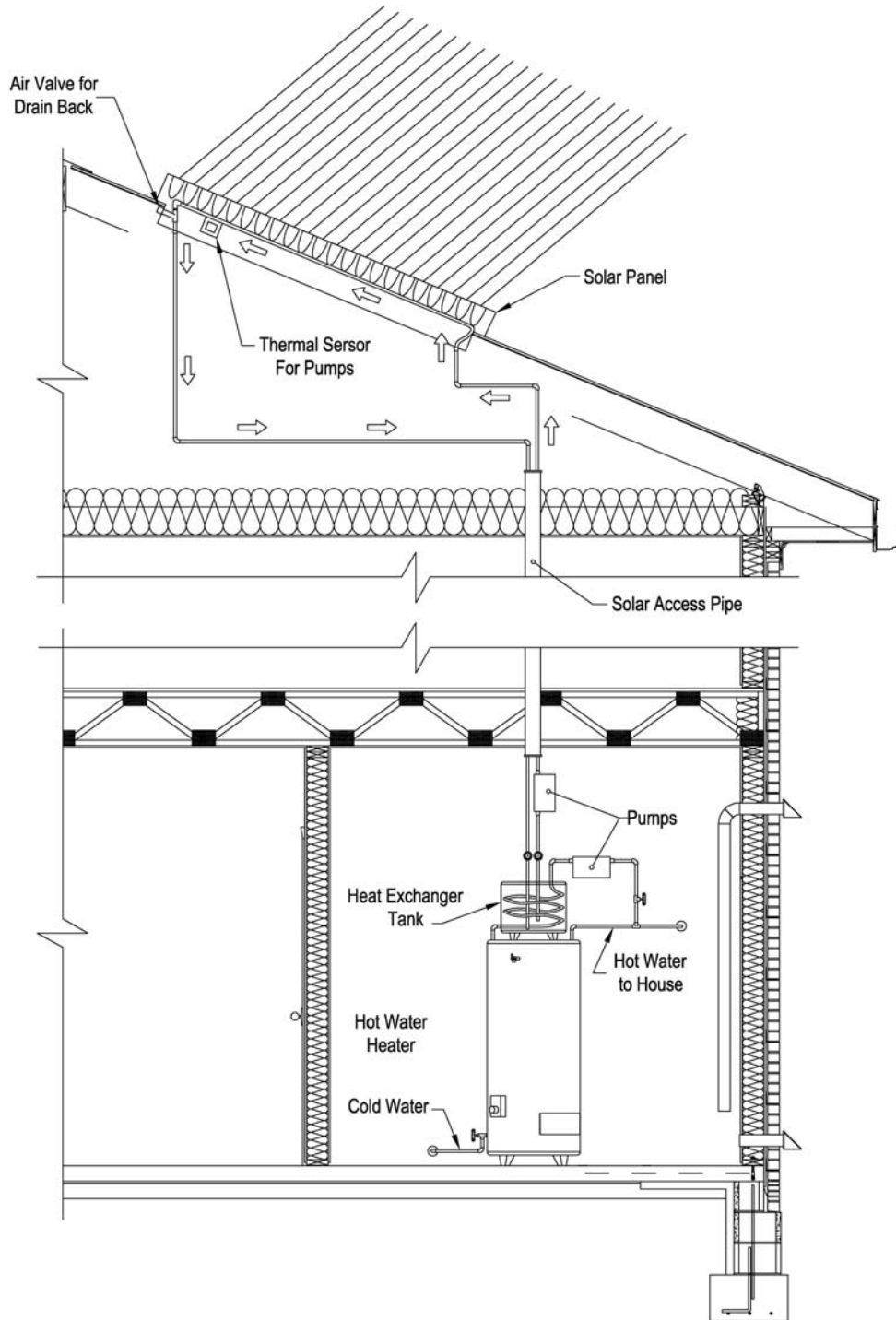

Figure 12 - 1 Closed Loop Solar Hot Water System: Drain Back System



The drain back system uses water as the heat exchange fluid. In order to provide for freeze protection, the pump shuts off when the temperature of the collector cools down below that of the tank, and the water in the system “drains back” into storage reservoirs. The panel then fills with air, protecting the system from freezing when the pump is turned off. Extreme caution should be used when this type of system is used because a failure in the drain back system would cause a catastrophic failure due to the collector freezing and bursting.

For both indirect and drain back systems, the solar collection loop is run to a heat exchange coil around a water storage tank. In that way, the systems are decoupled from the potable water delivered to the house.

PASSIVE SYSTEMS

A thermo-siphon system uses the tendency of water to rise as it is heated. In this system, a storage tank is installed at elevation above the collector. As the water is heated, it becomes lighter, and naturally flows up and into the top of the storage tank. The cooler water from the bottom of the tank flows down pipes to the bottom of the collector, creating the circulation through the system. As the temperature in the panel drops below the temperature of the storage tank, the circulation through the system stops as well. This prevents the cooler night time temperatures from removing heat from the system.

Thermo-siphon systems can also be designed with a closed loop and heat exchange fluid as well, in areas where freeze protection is required.

In the integral collector storage system, the storage tank is integrated into the solar collector. The cold water supply is connected directly to the collector. As water enters into the panel, the sun heats it up. However, unlike other systems, the water remains in the panel until there is a call for hot water, and then the water is drawn directly from the panel to fulfill the demand. Since the hot water is stored in the panel, integrated systems require larger storage tubes in the collector (to increase collection ability) than a normal direct system, which also helps prevent freezing. This is likely the simplest solar hot water system available.

DESIGN CONSIDERATIONS

The solar collectors should be placed on the south side of the building with the optimum tilt for the collector to be set to the azimuth angle for the location of the house. This is to provide the best year round performance of the system.

Due to the potential for high temperature water leaving the solar hot water system, a mixing valve must be installed on all systems to regulate the water temperature delivered to the house, and prevent any concerns about scalding. In addition, it is generally required to install some means of providing back up heat with any solar hot water systems to ensure that hot water demands can be met all year round. The simplest way to provide the back-up heat is with a small electric heating coil inside the storage tank. Alternatively, instantaneous water heaters can also be used. If instantaneous water heaters are used for a back up, they must be designed to handle the potentially elevated water temperatures from the solar panel.



PHOTOVOLTAIC PANELS

Photovoltaic (PV) panels are used as a means to generate on-site energy. The panels are relatively easy to integrate into the design of the house and power system, and are a means to reduce source energy consumption. One of the drawbacks is that, at this point in time, the cost of PV panels is high. While lower than a few years ago, the current cost still does not make them cost effective from a payback point of view. The amount of energy generated takes many years to pay off the initial cost of the panels. However, as the use and demand for PV technology increases and further advances in the technology increase the performance of the panels, the costs will continue to drop, making the technology more viable financially.

Photovoltaic systems require a collector panel and an inverter in order to produce electricity that can be used by the home (see Figure 12-2). Photovoltaic systems are either connected to a battery storage system located on site, or connected into the power grid of the community. For locations where connection to a power grid is not available or impractical, then a battery storage system is desirable. Battery storage systems however, do require maintenance to ensure that they continue to function adequately. When possible, tying into the local power grid is generally recommended over battery storage, due to the simplicity and costs. This removes the concerns with maintenance of the battery systems.

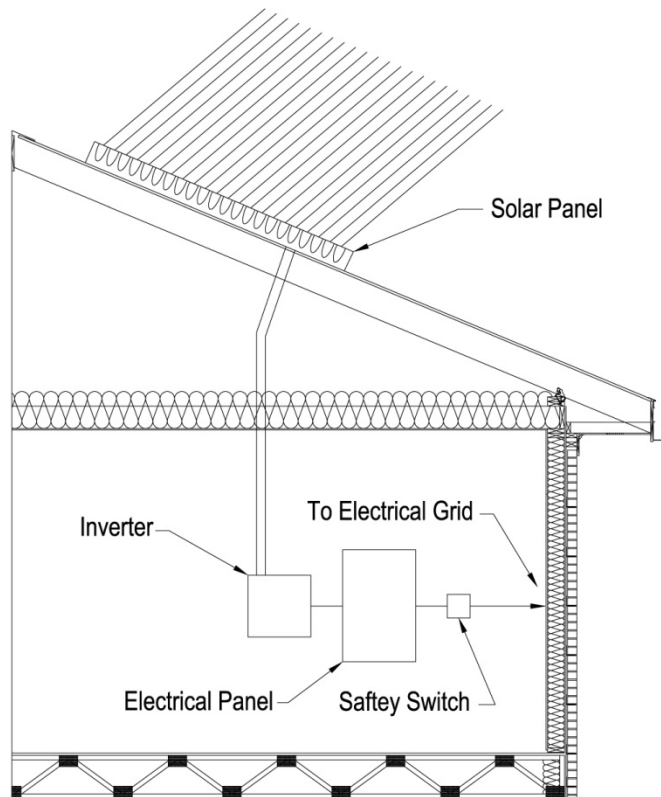

Figure 12 – 2 Photovoltaic System



DESIGN CONSIDERATIONS

There are several aspects of the design of photovoltaic systems that can affect the performance of the system. The location and angle of the collector, internal losses, shading, and temperature should all be considered in the design of the system.

The collector plate should be installed on the south side of the building.

Variations within 15 degrees of true south will create little change in the performance of the panels. However, beyond 15 degrees, the performance will begin to decrease. In addition, setting the tilt of the panel to maximize the summer time solar incident angle can increase the energy production of the panel over the course of the year. This can be more difficult than it seems as aesthetic issues often begin to come into play. It may not always be desirable to have the panel in a location of high visibility, and architectural design may limit the options for the collector tilt angle. If PV technologies are going to be incorporated into the design, it should be considered early on in the conceptual design stage, so that systems could be properly integrated into the aesthetic design of the building.

Most systems will experience some internal losses, and only reach approximately 80% to 90% of the rated output of the panel at a maximum. The losses are from dirt, dust, the resistance in the wiring, heating of the panels, and losses through the inverter. This is common for most systems and should be accounted for in the design of the system.

Even the least bit of shading of the panels can dramatically decrease the performance. This is due to the way the photosensitive cells are linked in the array. Therefore, it is very important that the panels be placed in a location such that surrounding elements (such as trees and chimneys) do not cast a shadow over even a portion of the panel. Ideally, the panels would also be cleaned, with some regularity, of dust, leaves, snow, or any other matter that might be deposited on the solar collector.

The performance of the panels is also affected by temperature. As the temperature of the panel increases, the output of the panels is reduced. Therefore, it is important to try to keep the panels as cool as possible. One strategy is to install the panels slightly off the surface of the roof, to allow for some ventilation behind the panel.





GLOSSARY

TERM	DEFINITION
2006 International Residential Code (IRC)	A comprehensive model building code for constructing one- and two-family dwellings and townhouses. The IRC establishes minimum regulations for all building, plumbing, mechanical, and electrical elements of the houses.
Advanced framing	Framing techniques that reduce the amount of wood used in the frame of a house.
Advanced Lighting Package (ALP)	Developed by the U.S. Environmental Protection Agency (EPA), the ENERGY STAR® Advanced Lighting Package identifies homes equipped with a comprehensive set of ENERGY STAR® qualified light fixtures. Some Green Building Programs have adopted this as a method of obtaining points toward certification. See Chapter 10.
Air barrier (system)	A series of concepts and construction methods that strive to eliminate leakage between conditioned and unconditioned spaces.
Air change	The amount of outdoor air needed to completely replace the air in a home; this is accomplished through infiltration and/or by a ventilation system.
Air changes per hour (ACH)	A measure of a home's leakage rate; the ACH estimates how many times in one hour the entire volume of air inside the building leaks to the outside. See Chapter 4.



Air handler	A device used to circulate air; part of the HVAC system.
Air leakage	Rate of air infiltration through an opening or crack in the presence of a specific pressure difference across it.
Air leakage control system	A series of concepts and construction methods that strive to seal all leaks between conditioned and unconditioned spaces using durable materials.
Air quality	The level of pollutants in the air, such as formaldehyde, radon, carbon monoxide and other harmful chemicals, as well as organisms such as mold, pollen and dust mites.
Air transport	The flow of air, containing water vapor, into enclosed areas through unsealed penetrations or joints between conditioned and unconditioned areas.
Air-Tight Recessed Light	Label on a recessed lighting fixture designating that the fixture does not allow more than 2 cfm air leakage at 75 Pascals (1.57 psi).
Airtight Drywall Approach (ADA)	An air sealing system that connects the interior finish of drywall and other building materials to form a continuous barrier. See Chapter 4.
Alignment	When installed, the insulation is in full contact with the air barrier (contiguous) and is continuous across the entire thermal enclosure. See fully aligned.
American Society of Heating, Refrigeration, and Air Conditioning Engineers (ASHRAE)	An international technical society, organized into regions, chapters, and student branches, which provides learning and teaching opportunities.



Annual Fuel Utilization Efficiency (AFUE)	A measure of the efficiency of a gas furnace; a rating, which takes into consideration losses from pilot lights, start-up, and stopping. It does not consider the unit's electricity use for fans and blowers. See Chapter 7.
ASTM (originally American Society for Testing and Materials)	An international standards organization that develops and publishes voluntary consensus technical standards for a variety of materials, products, systems, and services.
Backdrafting	Uneven pressure causing an exhaust flue to reverse direction and flow back into the room.
Balance point	The temperature at which a heat pump can no longer meet the heating load. The house may require a supplemental backup heat source.
Batt insulation	Insulation that is usually manufactured out of fiberglass or rock wool into precut 'blankets' sized for typical framing bays and manually fitted into place.
Blower door	A diagnostic piece of equipment used for measuring air-tightness. It consists of a temporary door covering, which is installed in an outside doorway, and a fan, which pressurizes or depressurizes the building.
Blown insulation	Insulation, either wet or dry, typically made from fiberglass or cellulose that is loose and blown into construction areas.
Break-even investment	The amount of money that can be invested in energy saving techniques such that the cost of the additional mortgage payment is equal to the energy savings. See Chapter 2.



BTU	<p>The British thermal unit (BTU or Btu) is a unit of energy used in the heating and air conditioning industry.</p> <p>A BTU is the amount of heat required to increase the temperature of a pound of water by one degree Fahrenheit. Because BTUs are measurements of energy consumption, they can be converted directly to kilowatt hours (3,412 BTUs = 1 kWh).</p>
British Thermal Unit per Hour	The hourly rate of heat flow, measured in Btu units (Btuh).
Building envelope	The exposed boundary between the conditioned portion of the home and the unconditioned area.
Bulk moisture transport	The flow of moisture (primarily rain) through holes, cracks, and gaps. See Chapter 3.
Cantilever	An overhang where one floor extends beyond and over a wall below, thereby exposing the floor to exterior conditions.
Capillary action	The wicking of water through porous materials or between small cracks, with rain or ground water as the primary source. See Chapter 3.
Capillary breaks	Various methods used to stop natural capillary action, such as plastic under concrete.
Casement window	A window that is attached to its frame by one or more side hinges. These windows are opened with a crank, and open fully for ventilation.



Caulk	To fill in the cracks or gaps in something, such as a pipe or a window frame, using a waterproof material in order to prevent the leakage of air or water. Caulking is a mastic or pliable material used to seal cracks, joints and penetrations in a dwelling's thermal envelope. See mastic.
Cellulose	A form of fiber insulation, made from recycled newsprint. Usually in loose-fill form, it is used for insulating attics; it may be either poured or blown. See Chapter 5.
Cfm	Cubic feet of air flow per minute. A unit of measurement of the flow of a gas or liquid that indicates how much volume, in cubic feet, passes by a stationary point in one minute.
Chase	A framed pathway, through the structure of a home, built to organize plumbing, wiring and ductwork.
Climate Zone	An area on a map, which identifies areas of the United States that have similar weather and climate patterns, for determining the code energy requirements.
Closed cell foam	Insulation foam that does not have interconnected pores. It is usually denser and has higher compression strength than open cell foams. The individual cells can be filled with a gas to improve insulation.
Code Home	A home that just meets the standards of the 2006 IECC. See Chapter 2.
Coefficient of Performance (COP)	A measurement of the heating efficiency of a geothermal heat pump. COP measures the number of units of heating or cooling produced by a unit of energy. See Chapter 7.



Color rendition index (CRI)	Measures the ability of a lamp to illuminate colors accurately. CRI is a quantitative measure of the ability of a light source to reproduce the colors of various objects faithfully in comparison with an ideal or natural light source. Light sources with a high CRI are desirable for applications in which color is critical.
Compact Fluorescent Lamps (CFL)	A type of fluorescent lamp, many of which are designed to replace an incandescent lamp and fit into the existing light fixture.
Compressor	A mechanical device that pumps refrigerant through the parts of a refrigeration system.
Compression	An insulation installation condition where the full thickness is reduced, resulting in increased density and reduced air pockets that drive thermal resistance. This undermines the effective R-value of the insulation.
Condensing furnace	A furnace model with an AFUE over 90%. It includes a special secondary heat exchanger that actually cools flue gases until they partially condense, so that heat losses up the flue are reduced.
Condensing unit	The exterior portion of a typical air conditioner that houses the compressor, which uses most of the energy and the condensing coil.
Conditioned space	The enclosed area of a home in which the climate has been adjusted and is controlled, through heating and cooling.
Conduction	The transfer of heat through solid objects, such as the ceilings, walls, and floors of a home. See Chapter 3.



Continuous insulation system	A series of concepts and construction methods that create as unbroken an insulation layer as possible between conditioned and unconditioned spaces.
Convection	The flow of heat by currents of air. See Chapter 3.
Convective air flow	Air-flow that occurs in gaps between insulation and the air barrier due to temperature differences in and across the gap resulting in a stack effect or driving forces from more to less heat.
Cooling Degree Days (CDD)	A measure of how warm a location is in the summer. It is the sum of the average daily temperature minus 65°F for each day of a year the average daily temperature is greater than 65°F.
Debt-to-income ratio	The percentage of a homeowner's monthly gross income that goes toward paying debts. Considering energy efficient home building, some lenders will allow a homeowner to borrow a little more money than is customary based on projected energy cost savings.
Dehumidification	Removal of humidity, using mechanical cooling equipment, from the interior air of a home.
Dew point	The temperature at which water vapor condenses. The temperature at which the air becomes completely saturated with water vapor (100% relative humidity). See Chapter 3.
Diffuse sunlight	One of the three forms of sunlight that reaches homes; this sunlight is bounced between the particles in the sky until it arrives as a bright haze.



Digital relative humidity sensor	A device used to measure relative humidity. The readings are typically displayed as a digital readout, so charts are not required. See Chapter 3.
Direct Gain passive solar design	A design in which south-facing windows allow sunlight directly into the living area, where a thermal storage mass captures the sun's energy.
Direct sunlight	One of the three forms of sunlight that reaches homes; direct sunlight travels as a beam without obstruction from the sun through a non-glazed or tinted window.
Direct-vent furnace	A furnace that does not rely on inside air for safe operation; combustion air is taken directly from the outdoors and exhaust is expelled outdoors. All of the gases that flow through the system are channeled and kept away from the inside air.
Double-hung windows	A window that is made of one or more movable panels or 'sashes' that form a frame to hold panes of glass. Half of the window area is available for ventilation.
Driving force	A pressure difference that forces air to flow through a hole in a home. See Chapter 3.
Dry bulb temperature	The temperature of air measured by a thermometer freely exposed to the air but shielded from radiation.
Ductwork	A series of tubular or rectangular pipes through which heated or cooled air can flow.
Eave	The edge of a roof. Eaves usually project or overhang beyond the side of the building to provide weather protection.



Electronic windows	A new type of window composed of special materials that can darken the glazing by running electricity through the unit. See Chapter 6.
Energy factor (EF)	A measure of the overall efficiency of a water heater and includes recovery efficiency, standby losses, and cycling losses. See Chapter 9.
ENERGY STAR®	A labeling system designed by the U.S. Environmental Protection Agency and Department of Energy.
EnergyGuide	A bright yellow and black label allowing comparison of energy usage between one appliance and another.
Enthalpy	A thermodynamic property equal to the sum of the internal energy of a system. See Chapter 7.
Envelope	The separation between the interior and the exterior environments of a home. The building envelope functions as an outer shell to protect the interior components and facilitates climate control.
Exfiltration	Air leaking from conditioned spaces in a home; the opposite of infiltration.
Fenestration	Products that fill openings in a building envelope, such as windows, doors, skylights, curtain walls, etc., designed to permit the passage of air, light, vehicles, or people.
Fiberglass	A type of fiber insulation made from long filaments of spun glass. See Chapter 5.



Flashing	Thin materials installed to prevent the passage of water into a structure from an angle or joint. Often used in roof or wall construction.
Floor truss	A structure comprising one or more triangular units constructed with straight slender members whose ends are connected at joints. A floor truss utilizes triangular units to support the floor.
Flue	A shaft, tube or pipe used to carry smoke, gas, or heat from a fireplace or a furnace to the outdoors.
Footer	The supporting base or groundwork of a structure, or wall.
Forced-air systems	A system with a central furnace plus an air conditioner or a heat pump. A forced-air system utilizes a series of ducts that distribute the conditioned heated or cooled air throughout the home. A blower located in the air handling unit forces the conditioned air through the ducts.
Fully aligned	A condition where air barriers and thermal barriers (insulation) are contiguous (touching) and continuous across the entire building envelope.
Fully supported	A condition in which insulation is evenly and securely held in place so that it does not bow or hang loose. Insulation that is not fully supported is more likely to be misaligned with the air barriers.
Geothermal	Energy available from naturally occurring geologic heat sources.



Geothermal HVAC system	A heating and/or an air conditioning system that uses the earth's ability to store heat in the ground. These systems operate based on the stability of underground temperatures.
Grille	Either a supply or return air fixture, with a frame and a louvered covering and no damper.
Ground reflected sunlight	One of the three forms of sunlight that reaches a home. This can be either direct or diffuse sunlight that is reflected off the ground into the windows of a home.
Heat pump	Climate control equipment that provides both heating and cooling, and is designed to move heat from one fluid to another. In summer, heat from the inside air is moved to the outside. In winter, heat is taken from the outside and moved to the inside air.
Heat recovery unit (desuperheater)	Used in water heating, this unit recovers excess heat from an air conditioner to provide "free" hot water. See Chapter 9.
Heat recovery ventilators (HRV)	Air-to-air heat exchangers, with separate duct systems that draw in outside air for ventilation and distribute fresh air throughout the house. HRVs transfer heat from exhaust air to inlet air.
Heating Degree Days (HDD)	A measure of how cold a location is, in the winter. It is the sum of 65°F minus the average daily temperature for each day of a year the average daily temperature is less than 65°F.



Heating Season Performance Factor (HSPF)	The measurement of the heating efficiency of a heat pump; a ratio of heat provided in Btu per hour to watts of electricity used. This factor considers the losses when the equipment starts up and stops, as well as the energy lost during the defrost cycle. See Chapter 7.
Home Energy Rating System (HERS)	A scoring system used to determine whether a home meets certain energy efficiency standards. See Chapter 2.
Housewrap	A material that contractors apply to the house's shell, that functions as an air and moisture barrier.
HVAC system	The heating, ventilating and air conditioning equipment within a home for climate comfort.
Hydro-chlorofluorocarbons	A type of foam insulation. See Chapter 5.
Icynene foam	A spray-applied foam insulation.
Inert gas	A gas that is not reactive with elements. Inert gas is a better insulator than air. Inert gas fills are heavier than air and circulate less, which reduces the convection currents between window panes.
Infiltration	Outside air passing through a home's shell, in an uncontrolled manner. Air leakage into the conditioned space may come through an attic ceiling, a leaky crawl space or basement.



Infrared Imaging	Heat sensing camera that helps reveal thermal bypass conditions by exposing hot and cold surface temperatures, revealing unintended thermal flow, air flow, and moisture flow. Darker colors indicate cool temperatures, while lighter colors indicate warmer temperatures.
Instantaneous water heaters	Water heaters that use higher capacity electric coils or gas burners to heat cold water only when there is a need for hot water.
Insulated Concrete Form (ICFs)	Factory-build wall system blocks that are made from extruded polystyrene insulation. Steel reinforcing rods are added and concrete is poured into the voids.
Insulated roof deck	A system where insulation is applied to the bottom or the top of the roofing material instead of the ceiling.
Insulation contact (IC)	Rating for recessed lights allowing insulation to be placed directly over the top of the fixture.
Insulation Contact, Air-Tight (ICAT) Lighting Fixture	Rating for recessed lights that can have direct contact with insulation and constructed with air-tight assemblies to reduce thermal losses.
International Energy Conservation Code (IECC)	A building code created by the International Code Council. It is a model code adopted by many states and municipalities in the United States to establish minimum design and construction requirements for energy efficiency.
Inverter	A device that changes direct current (DC) into alternating current (AC); the resulting AC allows electricity from photovoltaic systems to be used by a home.



Jumper ducts	A duct installed to connect the vent in one room with the vent in the next room, allowing air to flow back to the central return grilles. Useful in bedrooms with frequently closed doors.
Kentucky Residential Energy Code	A mandatory code for residential buildings based upon the latest International Energy Conservation Code of energy efficiency requirements.
Knee wall	A short vertical wall, usually less than three feet in height, with attic space directly behind it.
Latent cooling	Humidity removal or the drying of the air.
Latent load	The amount of dehumidification needed for the home to be comfortable.
Life-cycle investment	A long-term calculation that considers the life of the building components, accounts for future energy price increases and projects what the homeowner will see in savings over time.
Lofting	Installing too much air with loose-fill insulating products.
Low-emissivity coatings	Very thin coatings (metal or metallic oxide layers) designed to hinder radiant heat flow through multi-glazed windows. Coating a glass surface with a low-emittance material reflects a significant amount of radiant heat, thus lowering the total heat flow through the window.
Lumens	A measure of the perceived power of light; the measurement of the amount of light a lamp provides.



Manual D	A publication of the Air Conditioning Contractors of America (ACCA) used to size supply and return ductwork properly.
Manual J	A publication of the Air Conditioning Contractors of America (ACCA), which estimates heating and cooling loads for all types of residential structures. Manual J enables contractors to more adequately design, install, operate and maintain HVAC systems.
Mastic	Flexible cement for use in filler, adhesive sealant for ductwork.
Misalignment	Condition where air barriers and thermal barriers (insulation) are not contiguous (touching) and are not continuous across the entire building envelope.
Moisture barrier (system)	Construction and building practices designed to keep bulk (free) moisture from wood framing and the interior of a home.
Moisture control system	Quality construction that sheds water from the home and its foundation. The moisture control system also includes vapor and air barrier (infiltration) systems that hinder the flow of water vapor, and heating and cooling systems designed to provide comfort throughout the year.
National Environmental Health Association (NEHA)	A professional society designed to advance environmental health and protection for providing a healthful environment for all. Contractors working with radon need to be certified by the NEHA.



National Fenestration Rating Council (NFRC)	A non-profit organization that administers the only uniform, independent rating and labeling system for the energy performance of windows, doors, and skylights. This is a voluntary testing program, with the goals of providing fair, accurate, and reliable energy performance ratings for architects, builders, contractors, manufacturers and homeowners.
Non-direct vent furnaces	Furnaces that must receive adequate inside air for combustion and exhaust venting. They require a mechanical room vented to the outside.
Open cell foam	Insulation that contains pores that are connected to each other. Whatever surrounds open cell foam will fill it; the cell walls break and fill with air. This calm, trapped air provides the insulation value.
Overhang	A horizontal extension (awning, eave, etc.) which shades direct sunlight on windows.
Partition wall	A vertical panel, inside a home, that separates conditioned space.
Pascal (Pa)	A measure of perpendicular force per unit area (equivalent to one newton per square meter or one joule per cubic meter). It measures very small pressures. One Pascal = 0.004 inches of water.
Passive radon system	Construction of the components of a radon mitigation system during the original home construction, to be completed later, in the event of radon concerns.
Passive solar design	Home plans designed to capture the heat coming in from the sun; these must be designed with the local climate in mind.



Passive Solar Sunspace	In this design, the south-facing windows allow sunlight directly into the living area, where a thermal storage mass captures the sun's energy. See Chapter 11.
Pentane	One of the primary blowing agents used in the production of polystyrene foam.
Perm rating	Permeability is a measure of the amount of water vapor that is able to pass through an identified material in a specified amount of time. A perm is the unit for the measure and degree of permeability. Materials with a high perm rating will allow more water vapor to pass through than will materials with a lower perm rating.
Phase Change Material (PCM)	A substance capable of storing and releasing large amounts of energy. Heat is absorbed or released when the material changes from solid to liquid and vice versa.
Phenolic foam	Rigid foam board insulation. Phenolic foam is currently available only as a foamed-in-place insulation. Phenolic foamed-in-place insulation has an R-4.8 value per inch of thickness and uses air as the foaming agent.
Photovoltaic (PV)	The field of technology and research related to the application of solar cells for energy by converting sunlight directly into electricity. PV panels are used to generate on site energy.
Plenum	An enclosed space, to which one or more floors and air ducts are connected, for heating, cooling and/or ventilating air-flow.
Polyethylene	A plastic manufactured in large sheets, it is frequently used as a vapor barrier.



Polyicynene	A low-density, open cell foam that, when sprayed, quickly expands to 100 times its volume.
Polyisocyanurate	A closed-cell foam that contains a low-conductivity gas and is used as insulation. The high thermal resistance of the gas gives polyisocyanurate insulation materials an R-value typically around R-7 to R-8 per inch.
Polystyrene	An inexpensive, hard, extruded foam insulation product.
Polyurethane	A resilient, flexible, and durable manufactured material that has elastic properties while maintaining some rigidity; a component of caulk.
Pound per square inch (Psi)	A unit of pressure (lb/in ²). It is the pressure resulting from a force of one pound-force applied to an area of one square inch.
Programmable thermostat	A setback thermostat, which automatically adjusts the temperature setting when people are sleeping or are not at home. A programmable thermostat must be designed for the particular heating and cooling equipment that it will be controlling.
Psychrometric chart	A convenient tool for examining the interrelationships of temperature, moisture and air. The graph aids in understanding the dynamics of moisture control.
Pulse furnace	A furnace that is capable of achieving efficiencies over 90% using a spark plug to explode gases, which sends a shock wave out an exhaust tailpipe. The wave creates suction to draw in more gas through one-way flapper valves, and the process repeats.



Radiant Heat Barrier (RHB)	A highly reflective material that reflects radiant heat rather than absorbing it. RHBs purpose is to reduce the amount of heat transferred by the radiation process.
Radiant heating system	A combination of a central boiler or water heater with piping, to transport steam or hot water into the living area.
Radiation	The movement of energy in waves from warm to cooler objects across empty spaces, such as radiant heat traveling from the roof deck to the attic insulation on a hot sunny day.
Radon	An odorless, tasteless, invisible natural radioactive gas, widely found in the soil. Radon is a by-product of uranium.
Raised heel trusses	A heel is added at the end of every truss, raising the truss off the exterior wall, and allowing for a full amount of insulation to be installed. See page 84.
Refrigerant	A material that increases in temperature when compressed and cools rapidly when expanded.
Relative Humidity (RH)	The ratio (expressed as a percentage) of the amount of water vapor in the air, at a given temperature, to the maximum amount the air can hold at the same temperature. At 100% relative humidity, water vapor condenses into a liquid.
REScheck	Software, developed by the U.S. Department of Energy, which allows a home designer great design flexibility in achieving energy code compliance.
Return ducts	A series of ducts that brings air back to the HVAC system.



Rock and mineral wool	Fiber insulation (batt), mainly available as a loose-fill product. It is fireproof and many manufacturers use recycled materials in the production process.
R-value	A measure of the thermal resistance of a material. Higher R-values indicate better resistance to heat flow through material. The R-value is the measure of resistance to heat flow via conduction. R-values vary according to specific materials and installation.
Seasonal Energy Efficiency Rating (SEER)	The cooling efficiency of a heat pump or an air conditioner is rated by the SEER, a ratio of the average amount of cooling provided during the cooling season to the amount of electricity used. A measure of how readily air conditioners convert electricity into cooling; SEER 13 means that the unit provides 13 Btu of cooling per watt-hour of electricity. See Chapter 7.
Sensible Heating Fraction (SHF)	A designation of the portion of the cooling load for reducing indoor temperatures (sensible cooling). The HVAC unit with a 0.75 SHF uses 75% of the energy expended by the unit in cooling the temperature of the indoor air. The remaining 25% goes for latent heat removal, taking moisture out of the air in the home.
Sling psychrometer	A measuring instrument for relative humidity.
Soffit	The underside of a building component, such as the underside of a roof overhang, the underside of a flight of stairs or the underside of the ceiling to fill the space above kitchen cabinets.



Solar Air Collector passive solar design	One of the four basic passive solar designs; it absorbs incoming solar energy and then vents this energy through the back of the air collector. The solar-heated air is then transferred into the house.
Solar Heat Gain Coefficient (SHGC)	The fraction of incident solar radiation admitted through a window. The SHGC is expressed as a number between 0 and 1. The lower a window's solar heat gain coefficient, the less solar heat it transmits.
Solar tubes	Tubular windows that stretch from the ceiling, through the attic, and allow in daylight from the roof to light household areas with limited or no windows.
Solid windows	A new window technology, which uses gel-type material, up to one inch thick, between layers of glazing. These windows offer increased insulating value, but at present, are not completely transparent.
Sone	A unit of measure of the loudness of sound, subjectively perceived.
Soy-based foam	A sprayed-in insulation that is ultra-light weight. It is an open-cell, semi-rigid foam that emits no volatile organic compounds (VOCs) or CFCs and contains no formaldehyde.
Spray foam insulation	Insulation available in both open- and closed-cell configurations. It is sprayed into construction assemblies as a liquid that expands to fill the surrounding cavity. Once dry, spray foam functions as both an air barrier and thermal barrier and effectively fills holes and cracks for both a well-insulated and air-tight wall assembly. Closed-cell spray foams are denser and function as a vapor barrier.



Stack effect	Upward air pressure due to the buoyancy of air. The temperature difference between inside and outside causes warm air inside the home to rise while cooler air falls.
Structural insulated panels (SIP)	Factory-built insulated wall assemblies that ensure full alignment of insulation with integrated air barriers. They are composed of insulated foam board glued to both an internal and external layer of sheathing (typically OSB or plywood).
Structural system	A series of concepts and construction methods that consider the structural integrity of a home and the factors that affect this integrity.
Supply air duct	Part of the ductwork of the HVAC system used to deliver air.
Thermal barrier	Restriction or slowing of the flow of heat; it is accomplished primarily by using insulation, in conjunction with air and moisture barriers.
Thermal bridging	Accelerated thermal flow that occurs when materials that are poor insulators displace insulation.
Thermal bypass	The movement of heat around or through insulation. This typically occurs when gaps exist between the air barrier and insulation or where air barriers are missing.
Thermal bypass inspection checklist	Comprehensive list of building details for ENERGY STAR® Qualified Homes addressing construction details where air barriers and insulation are commonly missing.



Thermal insulation system	A series of concepts and construction techniques intended to reduce heat loss and gain due to conduction.
Thermal mass	The capacity of a material to store heat. When used correctly, it can significantly reduce the requirement for active heating and cooling systems. Any solid, liquid, or gas that has mass will have some thermal mass.
Thermal Storage Wall passive solar design	One of the four basic passive solar designs that utilizes a thermal storage wall to store incoming solar heat and let it radiate into the living area.
Thermo-siphon system	A passive solar hot water design that uses the tendency of water to rise as it is heated.
Ton	In HVAC equipment, 12,000 Btu per hour of cooling.
Transfer grilles	In a central duct system, the smaller, over the door vents, used to equalize air pressure.
U-factors	The rate at which a window, door, or skylight conducts non-solar heat flow. It is usually expressed in units of Btu/hr-ft ² -°F. U-factor ratings represent the entire window performance, including frame and spacer material. A lower U-factor means that the windows, doors, or skylights are more energy efficient. See Chapter 6.
UL-labeled	A label affixed to a building material or component, from Underwriters' Laboratories, Inc., indicating that the product has been subjected to appropriate fire, electrical hazard, or other safety tests.
Unconditioned space	The area of a home in which the climate is not controlled through heating and cooling.



Unvented conditioned attic assemblies	An insulated roof deck.
Urethane foam	A spray-applied insulation material, used to seal against air leakage.
Vapor barrier	A material whose purpose is to retard the movement of water vapor in air (those having perm ratings under 1); any material that restricts the flow of moisture.
Vapor compression cycle	The method by which refrigerant transfers heat by a combination of pressure changes and vaporization. See Chapter 7.
Vapor diffusion	The movement of water vapor in air through permeable materials.
Ventilation	The controlled movement and circulation of fresh air to a home.
Visible transmittance (VT)	A fraction of the visible spectrum of sunlight (380 to 720 nanometers), weighted by the sensitivity of the human eye, that is transmitted through a window's, door's or skylight's glass. See Chapter 6.
Watt (W)	A unit of power equal to the power produced by a current of one ampere acting across a potential difference of one volt (one joule of energy per second). It measures a rate of energy conversion; a human climbing a flight of stairs is doing work at the rate of about 200 watts.
Weatherstripping	The process of sealing openings, such as doors and windows, from the elements. A goal of weatherstripping is to prevent rain and water from entering a home. Another goal is to keep interior air in, thus saving energy with heating and air conditioning.



Wet bulb temperature	A type of temperature measurement, read by using a wet-bulb thermometer, which reflects the physical properties of a system with a mixture of a gas and a vapor, usually air and water vapor.
Wind baffle	An object that serves as an air barrier for blocking wind washing at attic eaves.
Wind washing	A term used to describe the situation when insulating properties of insulation are reduced due to air-current penetration.
Window flashing	A material installed around windows designed to prevent water from entering between gaps in adjoining building surfaces.
Winter and summer design temperatures	Temperatures used by heating and cooling contractors when sizing heating and cooling systems. The design temperatures show the temperatures that are exceeded in summer or dipped below in winter only 2.5% of the time.



ENERGY AND FUEL DATA

ENERGY UNITS

- 1 kBtu = 1,000 Btu
- 1 MMBtu = 1,000,000 Btu
- 1 therm = 100,000 Btu ~1 ccf of natural gas
- 1 quad = 1,000,000,000,000,000 Btu = 10^{15} Btu

POWER UNITS

- 1 watt/hour = 3.412 Btu/hour
- 1 kWh = 1,000 watt/hour = 3,412 Btu/hour
- 1 horsepower = 746 watts
- 1 ton of heating/cooling = 12,000 Btu/hour

FUEL UNITS

- 1 cubic foot of natural gas = 1,025 Btu (approximated by 1,000 Btu)
- 1 ccf of natural gas = 100 cubic feet ~100,000 Btu [c = Roman Numeral for 100]
- 1 mcf of natural gas = 1,000 cubic feet ~1,000,000 Btu [m = Roman Numeral for 1,000]
- 1 bbl fuel oil = 42 gallons
- 1 bbl fuel oil = 5.8 MMBtu
- 1 ton fuel oil = 6.8 bbl
- 1 gallon fuel oil = 136,000 Btu
- 1 gallon propane = 91,500 Btu
- 1 ton bituminous (Eastern) coal = 21-26 MMBtu
- 1 ton sub-bituminous (Western) coal = 14-18 MMBtu
- 1 cord wood = 128 cubic feet (4 ft x 4 ft x 8 ft)
- 1 cord dried oak = 23.9 MMBtu
- 1 cord dried pine = 14.2 MMBtu



CLIMATIC DATA

Cooling Degree Days (CDD) is a measure of how warm a location is in summer.

Heating Degree Days (HDD) is a measure of how cold a location is in winter.

Winter and Summer Design Temperatures should be used by heating and cooling contractors when sizing heating and cooling systems. These design temperatures show the temperatures that are exceeded in summer or dipped below in winter only 2.5% of the time.

Table 13-1 Equivalent Full Load Compressor Hours

Location	Winter Design Temp (°F)	HDD	Summer Design Temp (°F)	CDD
<i>Kentucky</i>				
Bowling Green	10	4,280	92	950
Covington	6	5,260	90	810
Lexington	8	4,760	91	920
Louisville	10	4,610	93	1,070
Owensboro	10	4,200	94	1,020
Paducah	12	3,650	95	1,160
<i>Tennessee</i>				
Chattanooga	18	3,380	93	1,150
Jackson	16	3,350	95	1,220
Knoxville	19	3,510	92	1,130
Memphis	18	3,210	95	1,300
Nashville	14	3,610	94	1,110
Tri-Cities	14	4,140	89	940
<i>North Carolina</i>				
Asheville	14	4,130	87	940
Greensboro	18	3,810	91	1,020
<i>Virginia</i>				
Roanoke	16	4,150	91	920
Winchester	10	4,780	90	820

