

# THE ULTIMATE REALITY

VOLUME 1

BY  
JOSEPH H. CATER



# CONTENTS

## **Part I: Incredible Flaws and Discrepancies of Orthodox Physics**

<b><u>Introduction to Part I</u></b>	<b>16</b>
<b><u>1. Undeniable Discrepancies in Conventional Science as Gathered from the Findings of the Space Program – The Researches of Charles Fort and Others</u></b>	<b>18</b>
<u>The Significant Work of Charles Fort</u>	31
<u>Evidence of UFO Interference and Participation in the Space Program</u>	35
<b><u>2. Incontrovertible Flaws in the Theory of Relativity and the Role it has Played in Current Trends of Cosmological Thought</u></b>	<b>37</b>
<u>The Origin of the Special Theory</u>	37
<u>The General Theory</u>	50
<u>Einstein's Influence on Modern Trends of Cosmological Thought</u>	59

## **Part II: The Nature of Forces that Shape Geologic History**

<b>3. The Cause of Tides and the Nature of Gravity</b>	<b>63</b>
<b>4. More on the Nature of Gravity and Directly Related Topics Which Include the Nature of Light, Soft Particles, the Ethers and the Reasons the Sun Holds the Planets in Orbit</b>	<b>73</b>
<u>The Reasons the Sun Holds the Planets in Orbit Despite its Low Surface Gravity</u>	77
<u>An Explanation for the Magnitude of Earth and Moon Gravity</u>	78
<b>5. The Cause of Earth Upheavals, Continental Drift, Earthquakes and Volcanoes</b>	<b>83</b>
<u>The Origin of Volcanoes</u>	85
<b>6. The Hollow Condition of the Earth</b>	<b>88</b>
<b>Summary of Part II</b>	<b>99</b>

## Part III: Developing a New Physics of the Universe from the Unifying Principle

<u>Introduction to Part III</u>	<u>101</u>
<b><u>7. Fundamental Weaknesses in Conventional Mathematics</u></b>	
<b><u>Including a Disproof of Two of the Most Famous</u></b>	
<b><u>Previously Unsolved Theorems of Mathematics</u></b>	<u>103</u>
<u>Four-Color Theorem</u>	<u>105</u>
<u>Fermat's Last Theorem</u>	<u>110</u>
<b>8. New Insights into the Nature of Matter, Inertia and the Ethers</b>	
<b>With an Introduction to The Meaning of Planck's Constant</b>	118
The Nature of the Ethers and the Meaning of Planck's Constant	119
<b>9. The Properties of Light</b>	129
Fallacies of the Transverse Wave Theory of Light	134
Resolving the Famous Wave-Particle Paradox	137
The Nature of Polarized Light	137
<b>10. The Nature of Electrons, Protons and Electrostatic Forces</b>	139
<b>11. Atomic Structure and the Nature of Magnetic Fields</b>	149
The Nature of Magnetic Fields	151
The Cause of Geomagnetism	163
<b>12. The Nature of Gravity and Related Phenomena</b>	
<b>Including Levitation, Missile Weight Loss in Space</b>	
<b>and Faster than Light Spaceship Propulsion</b>	167
The Nature of Gravity	167
The Phenomenon of Levitation	175
Missile Weight Loss in Space Points the Way to Development of	
New Materials of Extreme Lightness and Strength	177
The Possibility of Faster than Light Spaceships by	
Means of Gravity-Inducing Radiations	178
Fluctuations of the Gravitation Constant G	180
<b>13. A Closer Look at the Properties of Light</b>	182
The Law of Redistribution of Energy	183
The Phenomenon of Color	184
The Nature of Laser Beams	186
Why the Velocity of Light is Independent of its Frequency	190
The Basic Properties of Light	191
Why the Velocity of Light Equals the Ratio	
between EMU and ESU Units of Charge	192
<b>14. The Role of Soft Electrons in Promoting Chemical Changes and</b>	
<b>Maintaining Life and the Pyramid Phenomenon</b>	197
Soft Electrons, Magnetic Fields, and Chemical Changes	197
The Properties of Water	198
How Hard Particles are Captured by soft Particles	205
The Pyramid Power Phenomenon	211
The Great Work of Viktor Schauberger	216

Brown's Gas	220
<b>15. The New Cosmology</b>	<b>222</b>
The Source of the Sun's Radiant	
Energy and The Causes of Novas and Sunspots	222
Astronomical Errors in Determining Planetary Sizes and Distances	225
The Role of Giant UFO's in Cosmology	243
Recent and Obvious Changes in Venus' Orbit	247
Resolving Olber's Paradox, the Red Shift and Related Phenomenon	248
Fluctuations in The Velocity of Light	251
The Origin of Moon Craters	253
<b>16. An Explanation of Conductivity or Rules Governing the Transmission of Hard and Soft Electrons Through Various Materials</b>	<b>262</b>
Conductivity at Normal Temperatures and Atomic Field Zones	262
The Paradox of the Transformer and the Source of Electricity in Any Conductor	264
Superconductivity	270
<b>17. Peculiar and Unexplained Anomalies of Nature</b>	<b>274</b>
The Properties of Helium at Low Temperatures	274
"Mystery Spots" Including the Famous Oregon Vortex	276
Gravitational Anomalies	283
The Origins of the Van Allen Radiation Belt	284
<b>18. New Insights Into the Research of Wilhelm Reich</b>	<b>286</b>
Orgone Energy, Bions and Soft Electrons	286
The Oranur Experiment	292
The Cloud-buster	297
<b>19. The Nature of Radioactivity and Nuclear Devices</b>	<b>303</b>
Popular Misconceptions of Atomic and Particle Physics	303
A New Look at the Phenomenon of Radioactivity	306
The Source of the Energy Released in Nuclear Explosions	307
<b>20. Atmospheric Phenomena</b>	<b>316</b>
<b>21. Practical "Free Energy" Device which Could Revolutionize Our Way of Living</b>	<b>322</b>
The Self-Sustaining Electric Generator	323
The Great Potential of Crystals in the Obtaining of Free Energy	336
The Work of Tesla with Free Energy	343
<b>22. The Searl Effect and Related Phenomena</b>	<b>359</b>
Summary of Part III	370

## **Part IV: The Unifying Principle Applied to Borderland Phenomena**

Introduction to Part IV	371
<b>23. The Extraordinary Research of Baron Karl Von Reichenbach</b>	<b>372</b>
<b>24. The Pyramid of Life and the Unifying Principle</b>	<b>389</b>



<b>25. Resolving the Mystery of Teleportation</b>	402
The Philadelphia Experiment	408
<b>26. The Science of Psionics and the Fields of Life</b>	411
The Psionic Research of George De La Warr and Others	424
Color Therapy	425
Acupuncture	426
The Hieronymus "Cosmic Pipe"	428
<b>27. Materialization from Higher Realms</b>	430
<b>28. Misconceptions of Time and Space</b>	434
<b>29. False Illumination: An Analysis of the Scientific Efforts of Walter Russell</b>	438
The False Illumination of Yogananda	448
<b>30. The Reality of Thought Forms</b>	451
The Origin of Plant Life	457
The Nature of the Creative Process and Telepathic Communication	458
<b>31. The Law of Duality in Regard to Male and Female</b>	461
<b>32. The Origin and Transference of Disease</b>	464
The Nature of the Human Body	474
<b>33. The Work of Brunler in the Measurement of Brain Radiation and Intelligence</b>	483
<b>34. Miscellaneous Topics</b>	501
The Generation of Life from "Lifeless" Matter	503
The Transmutation of Elements	503
The Reasons the Earth's Magnetic Poles are not Located at the Geographic Poles	509
UFOs that are Life Forms	510
Terrifying Metamorphoses and Displaced Intelligences	512
Firewalking and Telekinesis	514
The Nature of Lightning Bolts	519
Levitation Produced by Sound	520
The Mystery of The Crystal Skull	522
Spontaneous Human Combustion	523
The Origin and Foundation of Astrology	525
An Analysis and Exposé of Eckancar, The Secret Science of Soul Travel	527
Communication with Higher Realms	529
The Production of Water From Certain Rock Formations	531
The Zone of Silence	532
Discrepancies in Conventional Explanation of Flight	535
The Nature of Sound and its Energy Effect	536
Mirages	538
<b>35. The Great Nuclear Scare Scam</b>	540
<b>36. The Secret War Waged Against the Population by The Power Elite</b>	546
<b>37. A New Look at Hermetic Philosophy</b>	553
<b>38. The Human Condition</b>	565
<b>39. The Great Work of Robert C. Beck</b>	580
<b>40. Summing Up</b>	586

## INTRODUCTION

The deeper mysteries of the universe have always been considered beyond human understanding. There is one important and almost self-evident principle such believers, who make up all but a few of the world thinkers, seem to overlook. Everything in the process of creation proceeds from the simple to the more complex. Every mechanical or electronic device, regardless of its complexity, operates according to a very few simple and easily understood principles. It follows that the universe should also comply with the same pattern, regardless of its near infinite complexity. This will be proven during the course of this treatise. Such a statement may seem overly optimistic and even blasphemous to many

The test for the validity of a theory or concept is its ability to explain and even predict a wide range of phenomena. The wider the range, the more likely it is to be correct. The principles and concepts introduced in this treatise more than live up to this standard. In fact, there is no known phenomenon not taken in stride by these new ideas. This reduces the probability to the vanishing point that they do not have validity. The power of the concepts presented is often demonstrated by the fact that some of the most baffling phenomena known, merely serve as confirmations of the truth contained in these ideas.

It is to be expected that such revelations would make a shambles of currently popular, and universally accepted ideas of conventional science. The trend of orthodox scientific thinking is diametrically opposed to reality. It seems to be the consensus that ever-greater complexities will be encountered, the deeper one probes into fundamental causes. In any event, orthodox, theoretical physics is in a deplorable state of confusion. It has become a hodgepodge of mathematical monstrosities. Profundity has usually been associated with complexity. In general, the latter is merely an indication of a perplexed state of mind with a very limited degree of comprehension. This describes the mind of the typical academic scientist.

The author is not likely to endear himself with the scientific community at large, and it is equally improbable that he will experience any remorse or guilt-complex over any unfriendly attitudes this treatise may engender. Fortunately, the members of the scientific community constitute only a minute percentage of the population. There are still many people whose minds have not been scrambled and ossified by institutions of "higher learning", and who have some degree of intelligence and common sense. Such individuals can find much of interest and value in this treatise, despite

the fact that only a very small minority could likely gain a complete understanding of the ideas presented.

For the first time in the history of this civilization, or perhaps any other, the seemingly impossible has been achieved. The physical sciences, the occult, metaphysics, and even philosophy have all been combined into a unified whole with no sharp lines separating them. This makes possible a far deeper insight into each of these subjects than was possible before. During the process it brings into sharp focus an important fact apparently ignored by a host of would-be theorists with their inexplicable speculations. One must comprehend the whole before an adequate understanding of any of its parts is possible. Such a presentation, within one volume, renders this book unique among all the others. As such, it cannot be categorized. Therefore, it should create a dilemma for librarians with their present system of classification.

It will be noted that the author has not been able to always supply the exact date and name of the publication from which certain information has been extracted. In such cases, he was faced with the option of either omitting or mentioning it. He always chose the latter. This, of course, is contrary to standard procedure and the rigid and unimaginative thinking of academic researchers. The reader can be assured that such information exists in some publication even if its author at the present time cannot put his finger on it. Inclusion of such information has added to the book and not detracted from it.

The author has also been criticized for treating speculation and theory as though they are facts. To put it bluntly, this is a reflection of a mind steeped in the inflexible rules of the academic tradition. It is true that every procedure designed to expand one's understanding of the universe starts out with a speculation, as was done extensively during the development of the new science revealed in the following pages. However, if such "speculations" turn out to be as fruitful as those introduced in this treatise, then it is safe to remove them from the realm of mere speculation and consider them facts. It has been found that as more new "facts" are uncovered, more support is given to these "speculations". The continual reminding of the reader that the material is based on speculation by continual use of such words as probably, perhaps, likely, etc., is not only poor writing style, but an insult to the intelligence of the reader. It is also an indication the author does not have a firm grasp of the subject matter.

Despite the vast wealth of incontrovertible evidence which supports the ideas presented in this treatise, the new science outlined in the pages to follow will never be accepted by a significant portion of the scientific community. It is difficult for a rational person to believe that minds exist which can mutually accept two contradictory ideas simultaneously and repeatedly reject undeniable facts which are contrary to accepted beliefs. It is even more inconceivable that there are many such minds among the

so-called intelligentsia of the population. Nevertheless, it is true. It has been the author's misfortune to encounter such individuals. Hopefully, such experiences can be kept to a minimum in the future. This book will also not be popular with such would-be theorists as mentioned above, whose egos far transcend their ability at theorizing. They have reproduced a number of books and articles expounding their highly nebulous concepts if indeed, they could be considered concepts. Such works may seem profound to the non-discriminating layman, and even to those who should know better. Unfortunately, they all have a number of things in common. They fail to define any of their grandiose terminologies and thus have proven to be inept at providing a clear-cut and tangible explanation of any phenomenon. They leave a vast network of dangling loose ends in their wake. If there is a lack of comprehension of basic laws one can't do otherwise.

This treatise is also unique in that it was written to hold the interest of readers whose intelligence range from average to the genius level. The subject matter is so varied and condensed the book requires many readings. The author has been besieged with questions from readers of his previous book, *The Awesome Life Force*, the answers to which are clearly revealed in the book. When and if this book is fully digested and understood, it will be found that the author has anticipated and answered practically any question or objection any reader may care to present

It should also be noted that the author has been criticized for the profusion of the somewhat less than complimentary remarks leveled at the scientific community. Some have even gone so far as to state such a policy is not the mark of a true scientist. In reality, such criticism is the mark of one who has failed to take an objective look at the world of academic science with the realization that the bulk of so-called scientists are not the paragons of integrity and the truth-seekers they would like the world to believe. After this treatise has been thoroughly covered and a fair evaluation has been made, it will be realized such diatribes are more than justified and long overdue.

Due to misconceptions and preconceived notions, truth is often distasteful. It has not been the author's policy to compromise it in order to please the reader. Consequently, he is not likely to ingratiate himself to many of those who digest this book, especially those with giant egos.

As already indicated, there is a surprising number of supposedly intelligent individuals who will not let incontrovertible facts and logic stand in their way of denouncing anything that is a threat to anything they hold sacred. The intelligent reader can rest assured that any detractors of this book will come under this category since, as he will find, the author does have an airtight case.

\*\*\*\*\*



## INTRODUCTION TO PART I

The image of the scientific community has been somewhat tarnished in the eyes of many thinking people during the past few decades. This is completely justified. Orthodox scientists, as a whole, are always the last to recognize or accept (if they ever do) any unusual fact or reality that does not fit comfortably into the picture of the universe as they see it. This is the case, regardless of any proof or evidence made available to them. A typical example is the much-publicized Sasquatch. The proof of its existence is beyond question, as far as rational minds are concerned. In fact, it would be difficult to find anyone outside the scientific community who is not convinced of its reality. The evidence is too overwhelming. Yet the scientific world is still doubtful. One commentator stated that the attitude of the scientists in this matter is more amazing than the Sasquatch itself. If this individual had investigated the record of the scientific community, he wouldn't have found this behavior so unusual. For ages, the vanguard or the status-quo of science has ruthlessly persecuted any legitimate pioneer who has tried to introduce a new idea, or made a discovery, which might question the validity of any established concept.

A present-day, innovative pioneer faces formidable odds in any attempt to present a revolutionary concept or discovery. He has not only the influential scientific community to contend with, but also its powerful allies behind the scenes who control the press, radio, and television. From a financial standpoint, it is to their advantage for things of a scientific and technological nature to remain as they are. Consequently, the old dogmas and fallacies of science still constitute the backbone of all school curriculums, textbooks, and encyclopedias where science is concerned.

Through such channels, the public is led to believe that many of the illogical speculations of orthodox scientists have been shown to be valid. For example, the existence of black holes and the validity of Einstein's theories, which have allegedly changed our conception of the universe, are now supposedly confirmed facts. The ideas and concepts introduced in the pages to follow will destroy such cherished theories. Part I will reveal some of the incredible flaws underlying the superstructure of modern, orthodox physics. Since there can be no fruitful coexistence of diametrically opposed concepts, this procedure is necessary to pave the way for the introduction of infinitely better ideas. If a garbage truck is to be converted to a carrier of vegetables, the garbage it contains must first be unloaded. After reading Part I, the reader will likely be surprised at how egregiously bad the logic underlying such theories as those of Einstein and others really are. He will wonder how such supposedly profound minds could commit so many blunders and why they had not been brought to light long before this book was written. The reasons will become apparent by the time he finishes this treatise.

To give the reader a still better idea of what is in store, two *reviews* of a previous work by the author will be presented, one of which is typical of the kind of praise given to the author's book *The Awesome Life Force* (It should be kept in mind this new treatise is a vast improvement over any of the authors work of the past).

The other review is an excerpt from a brief article by Richard Clark. It is interesting to note that about a year after writing this article, Clark for reasons that are not clear did an about face and started embracing the old out-moded ideas and concepts he had previously condemned.

## **The Awesome Life Force by Joseph H. Cater.**

Below is a typical review of the author's previous book.

(Published by Health Research, PO Box 850, Pomeroy, WA 99347 - 1984)

This reviewer is a graduate engineer from John Hopkins University who has been profoundly interested in the scientific reasons behind all results in our known and unknown universes. Many volumes have been diligently evaluated by myself to that purpose, but none have come even slightly close to this comprehensive work by Joseph Cater. I see this volume as the solid cornerstone for literally all of the future applications of scientific and metaphysical knowledge.

One chapter is entitled, "The Hermetic Laws of the Universe As Applied to All Phenomena". That is not an overstatement. The enormous bibliography and documentation of the points made leave no room for scientific skepticism when fairly and thoroughly evaluated.

Every person who is drawn to read this book will reap enormous benefits from it. It should be kept for constant referral, to be read and re-read -- and carefully evaluated. The subject matter is so widespread that any attempt to list the topics here would be only to cause a limiting prejudgment by the reader (which would be unfair to him). Much of the book is extremely practical not only for individuals but for all of society and world improvement.

To summarize -- any possible adjectives of praise simply pale and cannot do justice to this book. Anyone, absolutely anyone who is anxious about how the "things" in the universe come about must make this work a part of himself.

Laurence C. Marxer

### **Systems Technology : Sciencegate (The Awesome Force)**

I am fully aware of the disbelief of many of the readers of my papers. I welcome disbelief because it is a fundamental of the scientific mind. Every principle, every axiom, should be questioned. Unfortunately, most scientists question only new data which challenges established teaching and not the false dogmas which they are taught in school. If one believes that he knows the answers, he will never think to ask the right questions. If one refuses to

accept the false dogmas as truth, he will not receive a diploma and will be excluded from prestigious and lucrative positions. My disbelief in currently held principles in Physics, resulted in my being asked by the Physics Department of my university to abandon my studies in that subject, my subsequent pursuit of a doctorate in Mathematics, and the beginning of my quest for reality.

After you have read *Awesome Force*, by Joseph H. Cater, thought through the experiments, and possibly built some of the devices covered, you will come to the shocking realization that science, as currently taught in our universities, is a fabrication and monstrous hoax. It consists of outright lies, sloppy guesses, and nothing more. It is a political and social mind-control vehicle for the "Power Elite".

The "Power Elite" has gigantic hoaxes running in Finance, History, Medicine, Law, etc., but the hoax passing as Science has never been exposed until now. With its exposure, the other hoaxes will be seen for what they are and whom they profit. Science is *supposed* to be factual and representative of reality -- not a collection of myths to aid the "Power Elite's" control system. The prestigious institutions like Princeton, M.I.T., Stanford, Cal. Tech., Oxford, Cambridge, etc. are nothing but seminaries training the unquestioning in priestcraft. The supposed great names of science like Einstein, Oppenheimer, etc., were/are politically motivated, cunning reptiles. Their wild, half-baked theories like Black Holes, space-time warps, multi-dimension universes, the Big Bang, quarks, neutrinos, dual natured light, Relativity, etc., are pure fantasy. The texts and the journals of "Science" should be cataloged under science fiction in the library, if truth dictated their listings.

The "Power Elite's" small, special science group does *not* use science hoax data. They use flying saucers, particle beam weapons, anti-gravity systems, free energy devices, etc., as outlined by Cater. In fact, it was through the theft of Cater's data that the government learned about most of these amazing discoveries years ago. Only you and I, the profane, have been left out of the knowledge of reality. The "Power Elite" did this for our own good, of course -- also for profit and control. Just think of the billions of dollars that have been wasted on defense and space programs alone, not to mention the energy rip-off in the trillions of dollars over the years. The amazing thing is that they were able to get away with it -- up until now.



A sample of the information covered in Cater's book:

1. Gravity effects are produced by a highly penetrating *radiation* in the standard electromagnetic spectrum -- about a frequency of one trillion cycles per second, or just above radar frequencies, and just below the infra-red frequency.

NASA has had such devices for years.

2. Years before the Apollo missions, NASA had interplanetary space ships. The UFOs are real and *ours!*

3. The Earth is hollow and filled with giant caverns.

4. "Free Energy" devices can easily be built.

5. The Moon has a high surface gravity (rivals Earth's) and a dense atmosphere comparable to that of Earth.

6. Invisibility and intangibility beam systems have been developed.

7. Pyramid and Reich Orgone Systems are explained.

8. Psychic phenomena are explained.

# **PART I**

## **INCREDIBLE FLAWS AND DISCREPANCIES OF ORTHODOX SCIENCE**

### **INTRODUCTION TO PART I**

The image of the scientific community has been somewhat tarnished in the eyes of many thinking people during the past few decades. This is completely justified. Orthodox scientists, as a whole, are always the last to recognize or accept (if they ever do) any unusual fact or reality that does not fit comfortably into the picture of the universe as they see it. This is the case, regardless of any proof or evidence made available to them. A typical example is the much publicized Sasquatch. The proof of its existence is beyond question, as far as rational minds are concerned. In fact, it would be difficult to find anyone outside the scientific community who is not convinced of its reality. The evidence is too overwhelming. Yet the scientific world is still doubtful. One commentator stated that the attitude of the scientists in this matter is more amazing than the Sasquatch itself. If this individual had investigated the record of the scientific community, he wouldn't have found this behavior so unusual. For ages the vanguard of the status quo of science has ruthlessly persecuted any legitimate pioneer who has tried to introduce a new idea, or made a discovery, which might question the validity of any established concept.

A present-day, innovative pioneer faces formidable odds in any attempt to present a revolutionary concept or discovery. He has not only the influential scientific community to contend with, but also its powerful allies behind the scenes who control the press, radio and television. From a financial standpoint it is to their advantage for things of a scientific and technological nature to remain as they are. Consequently, the old dogmas and fallacies of science still constitute

the backbone of all school curricula, textbooks, and encyclopedias where science is concerned.

Through such channels, the public is led to believe that many of the illogical speculations of orthodox scientists have been shown to be valid. For example, the existence of Black Holes and validity of Einstein's theories, which have allegedly changed our conception of the universe, are now supposedly confirmed facts. The ideas and concepts introduced in the pages to follow will destroy such cherished theories.

Part I will reveal some of the incredible flaws underlying the superstructure of modern, orthodox physics. Since there can be no fruitful coexistence of diametrically opposed concepts, this procedure is necessary to pave the way for the introduction of infinitely better ideas. After reading Part I, the reader will likely be surprised at how egregiously bad the logic underlying such theories as those of Einstein and others really is. He will wonder how such supposedly profound minds could commit so many blunders, and also why they had not been brought to light long before this book was written. The reasons will become apparent by the time he finishes this treatise.

## CHAPTER 1

# UNDENIABLE DISCREPANCIES IN CONVENTIONAL SCIENCE AS GATHERED FROM THE FINDINGS OF THE SPACE PROGRAM -- THE RESEARCHES OF CHARLES FORT AND OTHERS

NASA as well as other interests has gone to great length to cover up the real findings of the space program. Such findings provide undeniable proof the most celebrated theories and concepts of conventional physics are completely erroneous. Despite all efforts to camouflage their program, leaks and slip-ups did occur. These leaks opened the door to many incredible revelations for any intelligent researcher with the necessary dedication and perseverance to take full advantage of the situation. Such findings will now be summarized. The following items are not mere speculation but are realities with a great wealth of factual evidence in conjunction with logical analysis to substantiate them

1. The Moon has a high surface gravity which rivals Earth's gravity.
2. The Moon has a dense atmosphere, and more extensive than that of Earth. There is a reason for stating the Moon's atmosphere is more and not necessarily denser than Earth's atmosphere. This will be explained in the chapter on cosmology. It involves the higher negative ion content of the Moon's atmosphere. (Later it will be shown that the Moon is much larger than astronomers claim).
3. Methods of propulsion of other than rockets were employed during critical stages of the Apollo missions. The space ships could not have carried sufficient fuel for the astronauts to reach the Moon and return because of the Moon's high gravity. The liftoff from the Earth with rockets was part of the great NASA cover-up.
4. The Earth (as all planets are) is hollow with a great egress, or entrance, into the Earth's interior that is hundreds of miles across. It is located in the north polar regions just south of the North Pole. Earlier satellite pictures of the Earth show this entrance quite clearly. Subsequent pictures released by NASA were doctored to



obliterate any evidence of such an entrance. Apparently, they neglected to do this with the earlier releases.

5. For years prior to the Apollo missions, NASA had space ships capable of interplanetary travel at its disposal. These ships employ fuelless propulsion systems similar to that of the highly publicized UFO (The principles will be analyzed later on in this treatise).

6. Gravity effects are produced by a highly penetrating radiation in the electromagnetic spectrum. It can be produced by mechanical means and used as levitating beams, as well as for a very effective method of propulsion. NASA has had such devices for many years. In fact, the U. S. Government sponsored experiments as early as 1958 that proved such devices feasible.

The Moon's high gravity was in evidence during the telecasts, despite the efforts of NASA to give the illusion of a low gravity. One of the tricks was slowing down the rate of transmission to make objects appear to fall more slowly, and give the impression that the astronauts were careful in order to remain moonbound. Nevertheless, there was an occasion when an astronaut tried a spectacular leap that no doubt was not in the script. He did no better than he would have on the Earth under the same conditions. Some photos refuted claims by NASA that the space suits included life-support systems weighing 185 pounds. For example, one of the astronauts was seen leaning over backwards with his supposedly heavy gear. If the weights were even a modest fraction of the claimed amount, he would have fallen over backwards. In order for him to have done this without falling over, the bulky pack he was carrying must have been empty. Evidence and research indicate that combined weight of suit and alleged life-support system did not weigh over 20 pounds. The earthlike conditions on the Moon and its dense atmosphere obviated the space suits. It seems the space suits were a cover-up in more ways than one.

A photo of one of the "great" jumping exhibitions of an astronaut graced the front pages of some newspapers. A caption under it read "Astronaut John Young jumps high while saluting the flag on the Moon today." He did get all of about 16 inches off the ground while saluting the flag. However, some basketball players often get three feet and more off the ground in a similar manner. However, in deference to John Young, it should be mentioned that had they been wearing space suits, they probably couldn't have jumped much higher on the Earth than did John Young on the Moon.

Another indication of a high gravity, the slowing down of the transmission could not hide, is that the running done by the astronauts on occasion, was identical to the running they would have done in Earth gravity. The length of the steps taken and the height above the ground was the same. The only difference was that the running was done in slow motion.

The anemic jumping feats of the astronauts under alleged, one-sixth Earth gravity, as shown on the telecasts, represent only part of the evidence of a high Moon gravity. The consistent reports of the point where the space ships entered the gravitational influence of the Moon indicated a Moon gravity comparable to that of the Earth. If the Moon's surface gravity were only one-sixth Earth gravity, this point of entry, or the point where the gravitational influence of the Moon exceeds that of Earth, would be approximately 22,000 miles from the Moon. This can easily be confirmed by elementary mathematics and mechanics and will not be given here. The distance will vary slightly percentagewise because the Moon's distance from the Earth fluctuates. Since the advent of the Apollo missions, the distance reported for this point of entry has been consistently much greater than 22,000 miles. The distances claimed by various writers, as well as the media, have varied from about 39,000 to nearly 44,000 miles.

This is, indeed, incredible since it contradicts the consistent claims of a low Moon gravity. Interestingly enough, prior to the space program this distance was always given in the 20,000 to 22,000 range, corresponding to one-sixth Earth gravity for the Moon. It can be found in a number of earlier textbooks, including *Encyclopedia Britannica*. Yet, the later editions of *Encyclopedia Britannica* put this distance at about the 40,000-mile range. There are many other indications of a high Moon gravity. (Later on in the chapter on cosmology powerful evidence will be presented which indicates the Moon is much larger and hence further away than is claimed. This, of course renders all distances as mere fabrications).

On many occasions, the astronauts had difficulty in handling or moving weights that under one-sixth gravity should have been child's play. This was emphasized in one notable case. The astronauts became exhausted during a rock-gathering trek while climbing a hill. They failed to reach their destination.

During one of the Apollo missions an astronaut stumbled and fell on his face on more than one occasion. Under one-sixth gravity even

a dotard with too much to drink could avoid doing this, even on one of his off days, and NASA doesn't pick stumblebums for astronaut material.

After this fiasco, a land rover was employed in subsequent missions. Interestingly enough, any mechanical engineer should have noticed it was designed for high gravity conditions instead of the low gravity the Moon is supposed to have. The rover was about 10 feet long and four feet high, with a 7.5 foot wheelbase and 6 foot tread width. The wheels were 32 inches in diameter. Each wheel had a one-quarter horsepower motor, which gave it a top speed of 10.5 miles per hour. It had an Earth weight of 460 pounds which would be only 75 pounds under one-sixty gravity. It is significant that the astronauts had great difficulty unloading it from the Lunar Module.

Prior to the space program, the problems anticipated on the Moon with surface vehicles were analyzed by experts. Stability would be a major problem because of weak gravity. Inertial properties would be the same as on Earth, but the wheels would have only one-sixth the traction. This means that sudden turns would be dangerous and braking problems would be colossal. It was determined that a minimum size vehicle would need a 20 foot wheelbase and a tread of 20 feet to give it any speed capability over rough terrain, and to keep the center of gravity within six feet of the surface. The long wheelbase would necessitate a higher center of gravity to give it reasonable clearance. This proposed design would insure that the vehicle would clear rocks and still maintain stability in gravity conditions that would easily overturn an Earth type vehicle such as the Rover.

Calculations show that the Rover, with a loaded Earth weight of about 1600 pounds, would need a turning radius of well over 80 feet to keep from turning over at 10 miles per hour under one-sixth gravity. Even at 5 miles per hour this radius would need to be over 20 feet. Its minimum stopping distance at 10 miles per hour would be more than 40 feet. It is apparent that descending steep hills without disaster would be an impossibility. Yet, the astronauts did descend steep hills and did some "Grand Prix" driving while making sharp turns at top speed. Photos of tracks made by the Rover indicate very sharp turns having been made at times. Even with the Rover, the astronauts had to stay within a six mile radius of the Module. This was the maximum walking distance back to the ship in the event of a breakdown.

One of the photos brought back from the Apollo 12 mission showed an astronaut carrying a barbell-like package of instruments with an Earth weight of 190 pounds. The pronounced bow in the bar holding the weights was not consistent with the claims that it had a Moon weight of only 30 pounds.

It is also interesting to note that the sky in this same photo showed unmistakable evidence of cloud formations.

Early in 1967 an unbelievable announcement came on a newscast. It was stated that Moon probes showed the Moon's gravity was very nearly the same as Earth's. There were contradictions among astronauts concerning Moon gravity. During an interview on radio shortly after the Apollo 11 mission, the author heard Neil Armstrong hint very strongly about the Moon having considerably more gravity than formerly believed. Later, other astronauts went out of their way to harp on the low, gravity conditions on the Moon. No doubt they were pressured to lie about their experiences. The various types of leaks mentioned above cause one to speculate whether such lapses were a result of deliberate attempts of some within the space program to sabotage the cover-up; or that they were victims of mind control by outerspace intelligences who might look with disfavor upon the mendacity of officials in the space program, or a combination of both.

There is considerable indirect evidence of a high Moon gravity. The most notable is the Moon's atmosphere. The proof of a dense atmosphere on the Moon is fully as convincing as that of the Moon's high gravity. Many viewers were puzzled at the billowing flags, the drifting of dust kicked up by the astronauts, and the fluttering of ribbon-like material on some of the instruments during a few of the telecasts from the Moon. Photos taken by the astronauts showed unquestionable light diffusion of the Moon. One of the photos including the Sun indicated a diffusion so pronounced the Sun's disc was obliterated and most of the sky illuminated. Light is not supposed to be diffused in the vacuum conditions said to exist on the Moon. The diffusion was incongruous with the black sky that appeared in all of the photos released to the public, except for at least one notable case. This exception the NASA failed to doctor showed a sky similar to that usually seen on the Earth during the day.

There was another interesting slip-up by NASA in the photo department. All the photos taken by the Moon orbiter, except one, showed an absence of any atmospheric fringe on the Moon's hori-



zon. The exception looked like a picture taken from an Earth satellite. A blue atmospheric fringe was very apparent along the far edge of the Moon!

Perhaps the most obvious indication of a dense Moon atmosphere is the soil and deep layers of loose dust on the Moon's surface. Such conditions cannot exist in a vacuum or near vacuum. Air molecules tend to adhere to surfaces. This layer of air tends to counteract cohesive forces, and prevents solid surfaces from adhering together or becoming "sticky". This, of course, prevents dust particles from coalescing and forming a solid, rocklike mass. This principle has been demonstrated on numerous occasions by placing soil or dust in a chamber and evacuating it to produce a near vacuum inside.

The evidence of a Moon atmosphere has by no means been exhausted. Much of it obtruded on the scientific world long before the space program. Considerable light refraction by stars being occulted by the Moon has been observed on many occasions. Meteors have been seen disintegrating in the Moon's upper atmosphere. In fact, evidence shows that the Moon's surface has better protection from meteorites than the Earth.

At this stage, it is interesting to refer to an article entitled, "How Dead is the Moon" that appeared in *Natural History* magazine for February, 1950, pages 62-65. It is extremely significant from several standpoints. There was a reference made concerning a scientist, Dr. Lincoln La Paz, in the 1930's, calculated that meteors weighing ten pounds or more falling on the dark side of the Moon should disintegrate in a flash bright enough to be seen with the naked eye. This is, of course, assuming the Moon has no atmosphere. Over 100 should occur every year, yet, only two or three such flashes have been seen in all human history. The conclusion was that the Moon seems to be better protected from meteors than the Earth.

In 1941, an astronomer, Walter Haas, and associates searched the dark side of the Moon for 170 hours with a telescope in an attempt to detect meteors burning up in a Moon atmosphere. During that time twelve bright moving specks which began and ended at points on the Moon were visible under their telescope. During these observations, four or five of our own meteors crossed the telescope field. One or two of the lunar flashes may have been extremely faint, earthbound meteors coming along directly toward the observer, but the laws of probability show most of them occurred on the Moon. According to the author of this article, it was assumed the density of

the atmosphere at the Moon's surface was 1/10,000th as dense as the Earth's. On this basis and the belief that the Moon had one-sixth Earth gravity, scientists calculated that above 43 to 55 miles above the Moon's surface, the atmosphere was denser than that of the Earth is at similar altitudes. This was supposed to account for the great protection the Moon's atmosphere provides the surface from meteor impact. It seems scientific reasoning in those days was as infantile as it is now.

It is obvious, or at least should be, the amount of protection an atmosphere gives a planetary surface is dependent upon the quantity of atmosphere existing above a unit area of the surface, not just its depth. In other words, it is the number of air molecules the meteor encounters, not the distribution that is the governing factor. On the basis of one-sixth Earth gravity and a density at the surface of 1/10,000th that experienced at the Earth's surface, the Moon has only 6/10,000th as much atmosphere per unit areas as the Earth. This conclusion is based on the fact that the volume of a gas is directly proportional to the pressure exerted on it. The gravitational field of a planet compresses the atmosphere and the amount of compression is almost directly proportional to the surface gravity. There will be a slight deviation because of the finite size of a planet. According to the above figures, our Earth would have about 1,666 times the atmosphere protecting its surface as does the Moon. This means that a meteor would encounter 1,666 times as many gas molecules before it reaches the Earth's surface than it would if it were to strike the Moon. Yet, the evidence indicates that the Moon's surface has better protection than the Earth's.

To make matters worse, a given amount of atmosphere compressed to a thinner layer under high gravity would actually give better protection from meteors than would the same atmosphere subjected to a lower gravity and thus be distributed over a greater depth. In passing through the deeper atmosphere, the meteor would encounter fewer gas molecules per unit time and would have more time to dissipate the heat built up by friction. By passing through the same number of molecules in a shorter time, it would get hotter. The time interval, being several times greater in the former case, would more than offset the fact that heat is dissipated more rapidly at higher temperatures.

When the process forming an atmosphere is considered, it follows that the Moon should have as much atmosphere per unit area as the

Earth. An atmosphere comes from gases discharged from material in the crust. Matter below a certain depth cannot contribute to an atmosphere. This is independent of the size of a planet but is dependent on the kind of material in the crust. The Earth and Moon have a similar composition.

Large areas of the Moon facing us are considerably lower than the average elevation of the Moon's surface. The mares on this side of the Moon make up a high percentage of the area and it is apparent they were once ocean bottoms. If we were to lose our oceans, most of the atmosphere would settle in the deeper ocean beds. As a result, such areas would experience great air pressures. A deeper and more dense atmosphere in such areas would, indeed, provide better protection from meteors than other places.

The dense Moon atmosphere is not as evident to viewers from Earth for several reasons. The long days and nights, coupled with lack of any very large bodies of water, mitigate the weather to the extent that strong winds and large cloud formations never occur. However, small clouds are seen occasionally drifting across the surface. Light diffusion is caused largely by suspended particles in the atmosphere. Due to the type of weather that exists on the Moon, there is a paucity of dust particles in its atmosphere as compared to the Earth's. Therefore, the Moon's atmosphere, although as dense on the average as the Earth's, will not diffuse light to the extent experienced on the Earth. Consequently, the scientific community has been able to fool people with their claims of a practically non-existent Moon atmosphere. This is certainly amazing in view of the fact that eclipses of the Sun do show a substantial Moon atmosphere despite its modest ability to diffuse light. An atmospheric fringe is clearly seen around the Moon's periphery. To squelch any claims that this fringe is part of the Sun's corona, it should be noted that this fringe also shows up in some photos of a partial eclipse where the outline of the Moon is overlapped by the Sun. It is entirely possible the Moon has even a denser atmosphere on the average than the Earth. This possibility will be discussed in Part III.

Other powerful evidence of a dense Moon atmosphere came from statements made by astronauts during Apollo missions. The following case is a typical example. Prior to the publicized excursions to the Moon, early astronauts had stated that the stars were not visible above the atmosphere. This is to be expected. There is little or no

diffusion of light in outer space and therefore, the only stars that could be seen would be those whose discs could be resolved. This could only be done with powerful telescopes. An atmosphere functions in a manner analogous to a lens. The light from a distant star is diffused and spread out. Consequently, stars are visible because of a greatly enlarged and distorted image of the disc caused by the atmosphere.

On the Apollo 11 mission shortly before reaching the Moon, Armstrong stated that he could see the crater Tycho clearly and that he could see the sky all around the Moon, even on the rim of it where there is no earthshine or sunshine. Collins then stated, "Now we're able to see stars again and recognize constellations for the first time on the trip .... The sky's full of stars ... it looks like its night side on Earth." This means that after leaving the Earth the astronauts could not see any stars until they got close enough to the Moon to view them through the Moon's atmosphere! (The pronounced yellow color of the Moon has never been explained and apparently the question as to why has never been asked. As will be shown later, this is additional proof the Moon has more atmosphere per unit area than does the Earth. It is interesting to note the Earth has a bluish color when seen from outer space).

An extensive Moon atmosphere means the Moon has a high gravity. Since the Moon is supposedly a relatively small planet, a gravity as weak as that attributed to it would be unable to hold an atmosphere of any significance. It is not difficult to see why the evidence of a substantial Moon atmosphere has been cheerfully ignored by scientists past and present. A strong Moon gravity, of course, is not compatible with orthodox physics.

Gravity effects are produced by a highly penetrating radiation in the electromagnetic spectrum. The frequency range is located between the lower portion of the infrared and the radar band. The frequency is approximately a trillion cycles per second and more precisely corresponding to wave lengths between 0.3 and 4.3 mm. The author transmitted this information to various scientific groups in 1958. Government-sponsored experiments soon confirmed the validity of this concept. This created considerable excitement among scientists involved, and rumors circulated about the discovery of an anti-gravity device. One of the scientists told John W. Campbell about such an experiment he witnessed. Campbell at that time was editor of the well-known science fiction magazine *Astounding*,



which later became known as *Analog*. He promptly inserted this information in one of his editorials. Evidently, the government took a dim view of such activities. In any event, Campbell's writing style suddenly changed. His editorials, which had been extremely speculative and thought provoking, now became relatively mundane and orthodox. The rumors also came to a grinding halt.

Many years later, a former associate of the author stumbled on to the same thing while experimenting with high frequency oscillators. His levitating of heavy objects with his device soon brought CIA agents down on him. He was forced to abandon his experiments and dismantle his equipment. He has been hounded and his activities have been under close surveillance ever since. He is fortunate to still be alive.

The application of gravity-inducing radiations to space travel is not difficult to understand. Everything in the path of the radiation is accelerated in a direction opposite to the direction of propagation. This means a properly located device attached to a spaceship can give it almost unlimited velocity. The occupants as well as the ship are not subjected to stress during acceleration, since the gravity-radiations impart the same acceleration to everything in the path. It would be somewhat naive to assume that NASA, or at least some segment or branch of it, didn't make use of this principle early in the space program, even though the public didn't know about it. The anti-gravity principle has no doubt been one of the most jealously guarded of all government secrets. There are well-founded rumors that men were put on the Moon as early as 1960. There is not the free exchange of information in the different parts of the military or the government that one might think. Money is not always channeled to the projects it was meant to subsidize. Each department has its own pet or secret project. It's a case of the right hand not knowing what the left hand is doing.

It follows that gravity radiation devices were employed to assure the success of the Apollo missions. Rockets were used for the liftoff from Earth to preserve the secret of antigravity and to satisfy those responsible directly and indirectly for the financing of the project. It is quite significant that photos of the liftoff of the lunar module from the Moon show no signs of any exhaust. The soft ground directly below it was in no way disturbed as it would have been had the crude rocket system been employed.



Films showing the complete liftoff sequence of the module are quite revealing. An initial blast from the rocket nozzle looked like a red plume extending from it. It stopped soon after the ascent stage separated from the descent stage. This initial display was no doubt staged to convince the public that rockets were the only means of propulsion. From this period on, the absence of a visible exhaust stream is quite evident. Those who might attempt to dismiss this evidence will likely assert that the exhaust would not be visible in a vacuum. This is very poor reasoning. Chemical rockets eject hot gases of a temperature of thousands of degrees Fahrenheit. As a consequence they will radiate light of a high intensity in an exhaust stream that extends a considerable distance beyond the exhaust nozzle. In fact, this exhaust stream would extend for a greater distance in a vacuum before dispersing than in an atmosphere. Collisions of ejected gases with air molecules would tend to produce rapid scattering. Since the greatest light intensity is in the exhaust stream itself, the exhaust would actually be more apparent in a vacuum than in an atmosphere. The exhaust gases and other products of combustion produce their own light. A typical academic "scientist" whom the author knows quite well argued that the ground below the rocket was not disturbed, because in a vacuum the exhaust products would be rapidly dispersed as soon as they left the nozzle! This argument violates the law of inertia.

Another aspect of the module which indicated rockets were not used for the liftoff was its aerodynamics. At high velocities it would have been very unstable. NASA stressed that this was of no concern because of vacuum conditions on the Moon. Since the Moon has a dense atmosphere, the velocity of the module had to be kept relatively low. This cannot be done with rockets because the fuel requirements become prohibitive at low velocities. This is consistent with the fact that the astronauts were standing up during ascent and descent. No appreciable deceleration or acceleration could have been tolerated by the astronauts under such a condition.

There are several reasons for the cloud of secrecy surrounding the discovery of anti-gravity. One of them is the preservation of the status quo of science. That fact that gravity effects are produced by electromagnetic radiations within a certain frequency range is enough to shatter the superstructure of modern theoretical physics. Concepts such as Black Holes, the General Theory of Relativity, popular ideas of cosmology and other misconceptions go down the

drain. As every physicist is fully aware, no electromagnetic radiation will effect in any manner the propagation or the direction of propagation of any other electromagnetic radiation which, of course, includes visible light. Radiations of the same frequency can produce the normal interference effects observed under special conditions which give the illusion that light is a wave phenomenon. Such experiments do not involve the different aspects of propagation which the concepts of Black Holes and general Relativity are dependent. According to general Relativity, a gravitational field is supposed to affect light the same way it affects any body or mass. The concept of Black Holes is an outgrowth of Relativity! A Black Hole is conceived as being a body of such enormous mass and commensurate gravitational field that no light can escape from it. Long before the discovery of the true nature of gravity, scientists should have been aware there was something seriously wrong with the concept that gravity does not discriminate. A rational and unbiased look at some natural phenomena reveals that gravity is very discriminating in its ability to attract different kinds of bodies. For example, clouds seem oblivious to the Earth's gravity and show absolutely no tendency to fall to the ground. Yet they are comprised of water droplets many times denser than the surrounding atmosphere and, therefore, defy the law of floating bodies. If Einstein's and other physicist's ideas about Relativity and Black Holes were valid then clouds could not exist for long. They would settle to the ground in a very short time. It might be argued that the viscosity of the air and air resistance prevents them from falling. This could only slow their rate of fall. Clouds of meteoric dust over 50 miles above the Earth also show no tendency to fall and the air at that altitude is less than 1/100,000th as dense as it is at sea level.

One "scientist", the author knows quite intimately (in fact an older brother), tried to explain the phenomenon away with the argument "Brownian movements" were responsible. Brownian movements are the random motions of tiny suspended particles in a fluid. It has been determined that unequal molecular bombardments at any instant on opposite sides of each particle produces the constant motion. What this illustrious gentleman failed to comprehend was that this phenomena in itself creates the same enigma as the inability of clouds to fall. Over a period of time the bombardments working against gravity will actually be weaker than the bombardments working with it. This is because the velocity of bombardment will be

slowed by gravity. Therefore, there will be a net force tending to force the particles out of suspension equal to the gravitational force on the particles minus the average force working against gravity. Fine dust can also be introduced in a perfect vacuum and it will not fall. (It has always been claimed that in a vacuum all things will drop at the same rate). The reason for this behavior will be presented later. If gravity has little or no effect on clouds or fine dust, how can it be expected to attract anything as tenuous as light?

Other facts equally damaging to orthodox concepts have been revealed by the space program. Views of the Earth from satellites show unmistakable evidence of a large egress from the hollow interior of the Earth in the north polar region. Early satellite pictures showed this entrance to be located just south of the North Pole in northern Canada. It is hundreds of miles across. After comments were made about the apparent opening in these early photos, subsequent pictures released to the public failed to show it. The experience and practice of NASA had in doctoring such photos no doubt "came in handy" so to speak when they had to cope with pictures taken on the Moon. One might explain away those earlier satellite pictures as merely showing unusual cloud formation. However, another satellite picture which appeared in November 10, 1967, issue of *Life* magazine is more difficult to dismiss. If such an opening does exist in northern Canada, then a satellite picture taken in the right position or where the line of sight is parallel to the plane of the opening will show a flat in the outline of the Earth. This is precisely what the *Life* magazine photo showed. It is about 1,600 miles across. It looks like a sizeable portion of the Earth has been sliced off and thrown away. It is significant that this flat is located in the same area as the opening in previous pictures of northern Canada. It was taken during the hurricane season or when the north polar region was still in view of the Sun. Once again NASA was caught napping. This same flat appeared in at least one picture taken from the Moon. (There is another large egress located in the vicinity of the south magnetic pole). The plane of the Moon's orbit about the Earth intersects the plane of the Earth's equator at an angle of about 28 degrees. This means the Moon will be in a position from which this flat can be seen for a brief period twice every lunar month. Fortunately, at least one of the Earth pictures taken from the Moon occurred at the time the Moon was in such a favorable position. The

flat showed up again in televised pictures, and in the same region of the Earth.

Since these lapses, it is evident NASA has tightened its "security" system. The public no longer sees gaping holes or truncated spheres at least as far as the Earth is concerned.

The concept of a hollow Earth is not compatible with the orthodox theories of gravity and other established concepts of conventional physics. Consequently, one can expect all-out attempts to suppress any facts or evidence indicating the validity of the hollow Earth concept. Later on in this treatise, it will be shown that the dogma of a solid Earth is a product of irrational and shallow thinking. It will also be established beyond question that our planet, like all other planets, is hollow.

Another important finding of the space program which understandably has received little publicity is missile weight loss in space. It was found that missiles returned to Earth after a sojourn in the Van Allen Radiation Belt lost considerable weight. For example, one missile with an original weight of 300 pounds only weighed 125 pounds at the time of recovery. The satellite even continued to lose weight afterwards. It was also found that the jar in which fragments of the recovered satellite were placed also lost weight. Such findings are among the most damaging of all to current theories of orthodox physics. This will be thoroughly analyzed and explained in Part III.

## THE SIGNIFICANT WORK OF CHARLES FORT

Few have ever dared to openly question the validity of the major concepts and supposed findings of conventional science. Fewer still have gone so far as to cast doubts upon the integrity of the scientific community. By far the most successful of them all, thus far, has been Charles Fort. He was born in 1874 and died in 1932. He devoted the last 21 years of his life to uncovering and recording strange phenomena, which scientists are still wishing had remained covered up. He compiled thousands of referenced notes during the process. From these notes he wrote four books entitled *Book of the Damned*, *Lo, New Lands*, and *Wild Talents*. They created a sensation



when they were published and open-minded readers and book reviewers were lavish in their praise. Reviews such as the following have been given:

*The most provocative, challenging, startling collection of occult and psychic phenomena recorded in the 20th Century -- by the brilliant and internationally controversial man who dared to speak out against blind ignorance. Fort's books not only liberate the mind from those sublimated hard dogmas of science. They also liberate the mind from all sorts of other prepossessions and idolatries of the marketplace.*

Those who read Fort with an unbiased attitude will find such evaluations are justified. It is expected that Fort did not show the scientific community in a favorable light. Therefore, it is no mystery that few, if any, scientists jumped on the bandwagon.

His books cite hundreds of instances of unusual falls from the sky, including various forms of marine life, rocks and boulders of all kinds, rocks with inscriptions, flesh, dead and mangled birds by the hundreds, bundles of hay, black rains, red rains, and even rains of blood, etc. In the realm of cosmology, his information was equally startling. References are given to dark shadows cast on the Moon covering a significant portion of it. Similar shadows have been cast on the Earth, blotting out the Sun and creating darkness over wide areas. The cause was never revealed. Fort also discussed UFOs thirty years before many people became aware of them.

He made brilliant observations puncturing some of the dogmas of science. For example, the constellations have remained fixed since they were observed by astronomers 2000 years ago. According to Fort, this seems to contradict the idea that stars are rapidly moving away from each other. If this were true, then some of the constellations should have lost some of their original shapes. This relative motion should have at least put a dent in the Big Dipper after 2,000 years; yet some stars have changed position to a considerable extent in just a few years, while all the others remained essentially fixed. Some stars disappeared and others appeared for the first time.

Many incredible blunders of astronomers are documented by Fort, as well as misleading claims that will not stand up under close scrutiny. For example, everyone has been led to believe the planet Neptune was discovered as a result of brilliant mathematical deduction and application of celestial mechanics, based on Newtonian concepts. Its exact position was determined by this method, and all the

astronomers had to do was point their telescopes in that direction. Careful research shows such was not the case. When Neptune was finally discovered, it was not in a position anywhere close to the calculated one. Fort noted that when pointing in a given direction, an astronomer, instead of using one finger, must use all his fingers in a widely separated position.

Fort also uncovered a strange coincidence where astronomers were concerned. It was found that the uncanny precision and accuracy of astronomical determinations always occur in areas that cannot be checked on by the public or even amateur astronomers. As an example; the accuracy of the calculated time and position of eclipses of the Sun is always far greater in the remote and unpopulated regions of the Earth. When they occur in civilized and heavily populated areas such as New York City, the errors do not conform with the accuracy generally attributed to modern astronomy. As will clearly be shown in the pages to follow, and especially in Chapter 15, accurate astronomical measurements are an impossibility, as far as present methods are concerned. Variable and indeterminate refraction effects of the Earth's atmosphere, as well as other factors to be discussed later, show that the astronomers have been deceiving themselves as well as the public. This, coupled with their proven lack of integrity and common sense, have made a mockery out of the so-called science of astronomy. In addition to the above factors, there is even a greater one involved where planetary motions are concerned. It is the fact that the orbits of all the planets are in the same plane. This means the astronomers are in a most unfavorable position in which to observe planetary motions. It requires little imagination to visualize the difficulties involved. It is very much different from a vantage point by which one could view the solar system directly above the orbital plane. By the time the reader digests Chapter 15, he or she will be shocked to learn just how far the astronomers have deviated from reality.

Fort probably foresaw the likelihood he might be labeled a biased cynic because of the unfavorable picture of the world of science he was painting. It seems he did make an effort to avoid such an image by showing the positive aspect of professional astronomers. His task was a formidable one, since it was difficult to find anything about them to laud. The more he uncovered, the darker the picture became. He did note that most, if not nearly all, of the significant discoveries were being made by amateur astronomers. He gave the professionals



the benefit of a doubt and assumed it was because they, the professional astronomers, went to bed early every night. He praised them for their high moral character! Such a fine gesture was never reciprocated by the astronomers or any member of the scientific community. Instead he was vilified.

Fortean phenomena also include the discovery of implements used by ancient people. The implements seemed to be made for people of all sizes, from giants to "pickle-sized" people. Among these was a stone axe weighing 300 pounds and other implements which have to be viewed with magnifying glasses. Evidence of strange and terrifying monsters that would be good subjects for horror movies was also recorded. All of this and much more is included in books of Charles Fort.

It is apparent many scientists in Fort's time behaved as illogically as they do today. They used inane arguments to explain away the Fortean phenomena. In the face of the unknown, they weren't able to act like true researchers and maintain an open logical thinking pattern. In turn, this eliminated all hope of using the valuable data to advance the frontiers of knowledge and gain a better understanding of the universe.

The image of the typical scientist the scientific community has tried to foster on the world deviates somewhat from reality. The search for, and the upholding of truth are supposed to be his primary aim. In addition, he is thoroughly logical and objective in his approach to any problem, as well as being open-minded. If this is the beautiful image some readers have naively harbored of scientists in general, the material presented thus far must be a shock to them. If so, there are still great surprises in store for them as this treatise unfolds.

George Orwell, in his famous novel *1984*, describes a mode of thinking termed "doublethink". In the novel, this was supposed to be the ideal state of mind and a goal worth striving for. It is the strange ability to accept two mutually contradictory ideas simultaneously. No doubt, many thought such a thing only a fantasy that could never happen in real life. They were wrong. Orwell had a remarkable insight into human nature. He was actually describing a type of thinking utilized by scientists for ages, as will be proven in the chapters to follow. Many physicists of the present day have become adept in this art. No doubt it has its rewards. It seems to have enabled them to live comfortably with concepts steeped in contradictions.

## **EVIDENCE OF UFO INTERFERENCE AND PARTICIPATION IN THE SPACE PROGRAM**

The mere existence of the UFO, with its extraordinary performance, poses a major threat to cherished beliefs of present day physicists. Their right angle turns at extreme velocities, sudden disappearances, and other antics tend to undermine the basic laws of Newton, the Einstein Theory, and other universally accepted ideas. It is small wonder the bulk of the scientific community still refuses to accept the idea they are more than just natural phenomena that can be explained away by established concepts or the old standby of weather balloons or hoaxes. It is difficult to understand the mental processes that enable a group to reject the reality of a phenomenon, in the face of such overwhelming evidence accumulating for decades, establishing its actuality beyond question. The members of such a group are indeed worthy candidates for mastership in the art of doublethink.

It is to be expected the UFO involvement in the Apollo program would not be publicized. A number of Canadian radios picked up the astronaut's broadcasts directly from the Moon. At least one Canadian newspaper published an account of the more significant parts of the conversation which transpired between the astronauts and their mentors in Houston. The Houston-monitored broadcasts deleted all of the UFO-related conversations.

It seemed on one occasion the Astronauts Armstrong and Aldrin were frightened out of their wits. A fleet of UFOs lined up close to the lunar module just after it landed. There is probably more than one reason astronauts go through a decontamination process after their return from such trips.

Peculiar activities occurring on the Moon have been seen by both professional and amateur astronomers over a period of many decades. This includes such phenomena as lights going on and off and changes in some of the Moon's craters. Numerous photographs taken by NASA show colossal, "man-made" structures and engineering feats which could make any on the Earth seem insignificant.

From the evidence presented in this chapter, it can be safely concluded there has been a coordinated effort by officialdom to sup-

press all of the facts discovered during the space program that are a threat to dogmas promulgated by institutions of "higher learning" in regard to the laws of physics and cosmology. Despite these precautions incredible breaches in security did occur which opened the door for such revelations as have been described above. In fact, the discrepancies in some instances were so horrendous they were even noticed by many observers who have been victims of academic brainwashing. People like Bill Kaysing were convinced that the Apollo missions were faked and staged in some remote area on the Earth. He no doubt believed that the Moon was airless and had one-sixth Earth gravity. If this belief were valid then the conclusion that the entire program was faked is inescapable. Consequently, he wrote a book in 1976 entitled, *We never went to the Moon*. His assertions have not been denied by NASA or the astronauts. They no doubt find it best to ignore them rather than assume the impossible task of explaining away all of the contradictions. The government and NASA would much sooner have the public believe Kaysing's book than to believe the astronauts reached the Moon and found earthlike conditions there.

From the above it can safely be concluded NASA officialdom has in the past and still consists almost exclusively of unconscious liars. This is evident in the case of the space shuttle. NASA of course has at its disposal infinitely superior craft that use no fuel. They would still have the public believe this crudity is the best they have. Large numbers of the scientific community also come under the above category as subsequent portions of this treatise will prove.

In conclusion, it should be noted that among all the astronauts, Armstrong seems to be the only one with any degree of integrity. He refused to lie about his experiences and seemed to hold himself aloof from the others. In fact he was the only one who did not attend the well publicized celebration of the 25th anniversary of the first alleged Moon landing. As to be expected, many of the astronauts continued to lie about conditions on the Moon.

## **CHAPTER 2**

# **INCONTROVERTIBLE FLAWS IN THE THEORY OF RELATIVITY AND THE ROLE IT HAS PLAYED IN CURRENT TRENDS OF COSMOLOGICAL THOUGHT**

### **THE ORIGIN OF THE SPECIAL THEORY**

Although the facts revealed in the previous chapter have shattered the Theory of Relativity, they are still not likely to convince the more ardent Einstein worshipers and zealots. This fallacy has become so deeply rooted in the consciousness of scientists and the rest of the world in general that it will not be easily disposed of, despite the fact it can be readily refuted from many different aspects. This concept has gained such a foothold, and become so much a part of modern physical theory, a mere demolition job on it will be inadequate. It must be completely pulverized from every conceivable angle. This will be accomplished in the following pages. Any reader who digests this chapter and remains an Einstein admirer should put this book aside and not read any further.

Before the advent of Einstein and the Theory of Relativity, the Transverse Wave Theory of light was universally accepted. Waves cannot exist without a medium to transmit them, or in other words, a medium which vibrates in some manner. Therefore, physicists postulated the existence of a subtle medium which permeates all space. They called it the ether. It follows that if light is a result of transverse waves transmitted through an ether, then, since the Earth travels through this ether in its path about the Sun, an ether drift should be detected. It's a situation analogous to sound waves being transmitted through a stationary atmosphere, and an observer moving through or relative to this atmosphere. His motion relative to the atmosphere would result in a wind, or atmosphere drift, according to his observations. Similarly, the Earth's motion through the ether should produce an ether wind. Experiments were devised to detect this ether wind, or drift, and its velocity. They are known as the

Michelson-Morely Experiments. A light ray was split into two parts, each traveled different but identical length paths, and then they recombined. The apparatus was mounted on a platform that could be rotated in any direction. It was correctly reasoned that if light were transmitted in the assumed manner, then at the point the rays were recombined interference fringes should be observed. Negative results were always obtained, to the consternation and amazement of the physicists.

Some explained away such results by assuming the Earth carried some of the ether along with it. If such were the case, it could certainly account for the negative results of the experiments. It was accepted by some of the famous physicists of the day but was rejected by the majority, although no sound arguments against it were proposed. Evidently, they all failed to realize the idea was contradictory. They were all aware of the fact that a body can travel through free space at a constant velocity and encounter no resistance. This means matter has no measurable attraction or affinity for this hypothetical ether. Light couldn't be transmitted through this medium in the manner assumed, without interactions taking place within the ether. It follows that no part of the ether can be displaced from the rest of it without encountering resistance. Therefore, the Earth could not carry ether along with it, and not experience the same kind of resistance. This would deaccelerate the Earth, and bring it to a stop. Likewise, no material body could travel through free space without requiring a steady application of force to counteract this resistance. Consequently, the orbiting of planets and other bodies would be an impossibility. Evidently, none of the scientists involved recognized this serious flaw in the above idea. One might have expected more from such a collection of distinguished intellects. It is not surprising in view of subsequent mental lapses concerning the interpretation of the experiment.

A similar mental lapse involved the aberration of light. It was noticed that where the Earth is moving in its orbit at right angles to the direction of a star, the star appears to be displaced from its true position opposite to the direction in which the Earth is moving. This effect is analogous to the apparent change in the direction a rain is falling when one moves along the surface of the Earth. From this angle of displacement the velocity of the Earth can allegedly be determined. (For various conditions as will be shown later, this angle cannot be accurately determined by the present methods).



The famous astronomer, Arvy, reasoned that since the velocity of light in water is only 3/4 that in air, the apparent direction of a star would be altered if the telescope tube were filled with water. He tried the experiment but found no change. This negative result was explained by the noted physicist Fresnel on the assumption the water dragged the ether with it. It is certainly incredible the obvious explanation escaped all of these famous intellects. The direction of the light rays entering and leaving the telescope will not be altered by the presence of the water since all parts of the telescope including the water have no relative velocity. In addition to this, the time required for the light to enter and leave the telescope in each instance is much too infinitesimal to be a factor.

The Michelson-Morely Experiments actually proved that the assumption that light is propagated as transverse waves through an all pervading medium is not valid. He would, therefore, have concluded the Transverse Wave Concept is not necessary to account for the diffraction and interference effects of light. The physicists were unable to reject the Transverse Wave Concept. Therefore, the only way out of the dilemma created by the results of the Michelson-Morely Experiments was the absurd conclusion that the observed velocity of light was independent of the velocity of the source or that of the observer. In other words, the velocity of light is a universal constant. This idea, of course, violates the principle of relative velocities encountered in all of our experiences. This is clearly a case of doublethink.

With this as a starting point, the physicist H. A. Lorentz derived a set of equations bearing his name. As expected, they predicted an assortment of ridiculous phenomena such as:

1. Time slows down on a moving system. In other words, if two systems are moving relative to each other, an observer on each one will note that the clock on the other system is ticking off the seconds more slowly than his clock.

2. A body will shorten in the direction of motion and the dimension will approach zero, as its velocity approaches that of light.

3. The mass of a body increases with its velocity and approaches infinity as the velocity approaches that of light.

In 1903, a physicist derived the famous equation  $E = mc^2$  from the Lorentz equations. This was two years before Einstein was heard of. Most of the physicists considered the conclusion derived from the

Lorentz equations little more than mathematical oddities, since they were somewhat unpalatable and difficult to believe.

This was the state of the art when Einstein got into the act in 1905. He proceeded to compound the original error. He devised new interpretations for the Lorentz equations by transforming them into something that was supposed to have physical reality. Physicists were still in a daze over the results of the Michelson-Morely Experiments, and apparently their mental state made them vulnerable to any idea, regardless of how illogical it might be. Consequently, Einstein's ideas were readily accepted and he was hailed as the man who saved physics. He was also given credit for the equation  $E = mc^2$ . It will be proven in Part III this equation is meaningless and represents only a minute part of the physical energy contained in any given mass. This monstrosity that Einstein put the finishing touches on became known as the Special Theory of Relativity.

If the mathematics used to develop a theory are valid but the basic premise is wrong, the final conclusion will also be wrong. It is simply a cause and effect relationship. The conclusions will reflect the characteristics of the original assumption. The algebra of the Special Theory is valid, therefore, the conclusions are necessarily as vacuous as the original assumption. A review of the conclusions just mentioned is in order.

A body is supposed to shorten in the direction of motion, and this dimension will approach zero as its velocity nears that of light. With this conclusion, two mutually contradictory statements emerge. Since one of the dimensions of a body tends to vanish, the body itself will tend to disappear, yet according to a conclusion mentioned earlier, its mass becomes infinite!

Einstein tried to explain away the "apparent" shortening of bodies in the direction of motion by the following example: Four men undertake to measure the length of a moving railway train by two different methods, two of the men riding on the train, stretch a tapeline between them and measure the length in the ordinary way. The other two stand on the ground beside the track and upon a pre-arranged signal being given each observer reads the position of his end of the train on a tape. From these readings they determine the length of the train. The Theory of Relativity asserts that these observers cannot arrange a signal so that both of them may receive it at the same time and since they do not read the positions of their respective ends of the train at the same instant they do not obtain the true length of the

train. To the observers on the ground, it appears that the length of the train depends on its speed. The faster it goes the shorter it is.

Perhaps the reader has already detected the flaw in this specious argument. Einstein is confusing a hypothetical experiment with an actual one. In real practice, of course the two observers could not set the position of each end at the same instant for obvious reasons but theoretically it is possible. This nullifies his argument.

The conclusion that time slows down on a moving system presents another impossible situation. Consider the case of the observers on two systems moving relative to each other. The observer on each system is noting the behavior of the clock on the system moving relative to him. Each one notes that the other clock is losing time relative to his own. The systems finally return to each other and stop. According to the Lorentz equations, each observer should notice the other clock has lost time relative to his own. Einstein had originally stated that the time equation for each system is equally valid. In other words, it doesn't matter which is taken as the moving system. Earlier writings on Relativity by the authorities continually reiterated this.

The reality of this troublesome enigma must have eventually filtered down to the consciousness of the more "brilliant" physicists, since now the consensus is that only one of the observers would have this experience; and it did matter what was considered the moving system. By seeming to avoid this dilemma, our resourceful relativists are faced with another equally distasteful one. Some of their other beliefs are dependent on the assumption that each moving system deserves equal consideration, which is a factor they have now rejected.

According to them, the one to be considered as the moving system is the one that has been subjected to an acceleration to acquire its velocity. Which is to be considered the moving system, if both have been subjected to the same accelerating force, but in opposite directions? In any event, the ability to doublethink has come to the rescue of many physicists in the face of such a potentially disastrous situation, and they have done the only thing possible. They have ignored the dilemma.

At this stage, it is interesting to note how a well-known science fiction writer has handled this clock paradox of Relativity. This particular individual, a typical orthodox scientist, has been essentially a mouthpiece for the scientific community over a long period of time.



He has written over 200 books covering a wide variety of subjects. His fame initially came through his science fiction writings. He is now looked upon as an authority on all things of a scientific nature. It will become increasingly apparent as the reader continues that this "authority" should have confined his activities to science fiction only. This is essentially about all that he wrote anyway. Much of his writings have merely been improperly labeled. An article of his on the time paradox appeared recently in a science magazine of considerable popularity.

He began the discussion with the false and highly misleading statement that the Theory of Relativity has met all tests without exception, and so triumphantly that no physicist now doubts its validity. These "tests" and their alleged confirmation will be discussed shortly. This writer tackled the paradox by avoiding the real issues. He admitted that the Special Theory of Relativity is inadequate to deal with the situation, since it is supposed to apply only to objects traveling at a constant velocity. According to him, this means the two systems, having flashed by each other, must continue to separate forever if the Special Theory is to be involved. They can never come together again to match clocks. Therefore, there is no paradox!

To the less gifted readers of this article, this specious evasion may have appeared to take the Special Theory off the hook, but did it? The theory is supposed to apply to any velocity below that of light. Therefore, the velocity can change, and during the change the theory should still hold for any velocity assumed at any instant during that change, and afterwards. The paradox thus remains, despite the ostrich type of thinking that tried to sweep it under the rug.

Attention was then focused from the Special Theory to the General Theory which Einstein proposed in 1916. Armed with this aspect of Relativity including accelerated objects, our resourceful and daring writer tackled this time paradox again. He argued that the General Theory of Relativity shows it is the ship that undergoes acceleration that experiences a real change in the rate of time. The ship that undergoes acceleration will end with its clock behind when the two systems approach and compare. The system called A that doesn't accelerate will notice that only B, the accelerating system, will appear to accelerate while B is the only one accelerating relative to the universe and A likewise. By this argument, the slowing of time is supposed to be real. This means the occupants of a space ship that accelerates up to near the speed of light and maintains this velocity

will show little or no tendency to age. During the process, their clock will seem to them to be ticking the seconds off as rapidly as before.

It might appear this much loved and respected writer resolved the time paradox. During his vacuous arguments, he carefully avoided the case of the two spaceships undergoing identical accelerations in opposite directions, before coming together once more and stopping. This brings the paradox back to life again with as much vigor as it ever had. Other scientists with less daring and perhaps more wisdom have remained silent on the issue. No doubt with the hope that if they closed their eyes, it would go away. The identity of this distinguished writer is already apparent to most readers. He is, of course, Isaac Asimov, a perfect example of the typical academic scientist whose peculiar mental characteristics and vacuity will be thoroughly analyzed and demonstrated during the unfolding of this treatise.

The time paradox, of course, is only one aspect of the contradictions and basic fallacies of the special theory. For example, one of the conclusions is that the mass of a body increases with its velocity and approaches infinity as the velocity nears that of light. This contention is easily disproved. At times, hypothetical experiments are extremely useful to illustrate a principle, or demonstrate the fallacies of a concept, even though Einstein tried it on occasion, but never with effect. This method will be employed to demonstrate the absurdities in the above idea.

Consider a closed system or one in which no energy in any form can enter or leave. Inside this system are two bodies heavily charged with the same electricity. Being of like charge, they have a tendency to repel each other. They are prevented from flying apart by a string holding them together. Assume that a little demon with a knife cuts this string. The two charged bodies then fly apart at a high velocity. According to Einstein, these bodies have gained in mass. This means an increase in the total mass energy of the system and also the total energy available in same. This violates the energy conservation law, and something has been created out of nothingness.

Although this adequately demonstrates the fallacy of the relativistic increase of mass with velocity, the author was surprised to learn it did not satisfy all members of the scientific community, Linus Pauling, in particular. In 1983 this writer learned he had referred to soft particle physics as nonsense although he hadn't read any of the author's work. A letter was immediately fired back to the old gen-



tleman clearly pointing out what he thinks is nonsense is actually reality and what he believes are realities are actually nonsense. The letter included the above argument concerning increase of mass with velocity along with numerous other incontrovertible proofs the entire foundation of conventional physics is steeped in fallacies. The answer I received was what one would expect of a typical academic "scientist." The first brief paragraph read: "I have read the first part of the letter that you sent to me recently. I did not read the whole letter because it soon became clear to me I could not rely on the statements in your letter." Unquote. The specious arguments which followed was essentially that the energy required to bring the two charges together was given back when the charges flew apart and thus there was no increase in the total mass energy of the system. This is quite true but it only holds if the mass of the two particles do not change. What this revered patriarch evidently failed to take into consideration is the energy conservation law must hold at all times. This means it is immaterial what happened prior to the time the particles were brought together.

It is interesting he made a point of not reading the rest of the letter since it contained the more cogent and potent aspects of my letter. What a nice way of avoiding having to deal with it! The author then answered him with the above argument and followed it up with one still more convincing which consisted of the following.

Consider a planet of near infinite size with no atmosphere. A certain mass is raised to a given height above the surface and allowed to drop. By the time it reaches the surface it will have acquired a kinetic energy equal to the energy or work required to raise it to the altitude from which it was dropped. This is in accordance with the energy conservation law. Now the kinetic energy equals one half the mass times the square of the velocity. This means that the mass must remain constant in order for the conservation law to hold. According to Einstein and other relativists, gravity doesn't discriminate. This assumption is an integral part of the theory.

Therefore, the acceleration of the mass as it falls will remain constant, regardless of any increase in mass! Therefore, the kinetic energy of the falling body will exceed the energy required to raise the mass to the required elevation. This also demonstrates an inherent contradiction in the Relativity theory. It is apparent that the velocity will increase without limit depending on the height from which it is dropped. As the mass approaches infinity, the gravitational pull will

keep pace and exert a force approaching infinity. It will be shown later that the velocity under these conditions will reach a limit, but it will be many times that of light.

Among other things the author also presented him with another clincher. The behavior of light shows conclusively that mass does not increase with velocity. Photons of light, of course, travel at the velocity of light but display a finite mass and momentum. Relativists get around this paradox by assuming a rest mass of zero. However, if this is so, then they will also have a zero mass at any velocity less than the velocity of light in free space. Photons moving through the atmosphere travel at a lower velocity than this, yet they show the same mass and momentum!

What did this "astute" old Nobel Laureate do in the face of this? He fired back another letter completely ignoring the fact he was checkmated and focused entirely on the same old topic while intimating the author didn't comprehend elementary physics! If this were the case, it seems logical to assume he would have been compelled to read *all* of the writer's letters in order to gather more ammunition to unload on him. The author of course dropped more bombs on him and he responded once more with the same gibberish. The last letter the author sent must have finished him off. It was like a fighter getting knocked down four times before he goes down for the count. Each time he gets up he is more groggy than he was after the previous knockdown. He at least showed gameness if a lack of good intelligence. Other members of the scientific community who have been dumb enough to challenge the author have followed the same policy. They refused to meet him head on and pretended they either hadn't read this writer's arguments or had completely misinterpreted them. It is left up to the reader to decide whether or not this venerable old patriarch lied when he claimed to have not read the rest of the author's first letter.

Physicists will argue that particle accelerators demonstrate this relativistic increase in mass. Such experiments, instead of confirming Einstein, actually demonstrate a very important principle providing a better understanding of many physical phenomena.

It is an established fact that a magnetic field develops around a charged body when it is given a velocity. Where did the magnetic field come from? Consider again the experiment just described. As the bodies moved, magnetic fields developed around them. Since the total energy of the system remains constant, there can be only one

conclusion. The magnetic field developed at the expense of the electrostatic field. This is a transformation of one form of energy into another, or potential energy into kinetic energy. What really takes place in the particle accelerators can now be understood. As the charges in the accelerators increase their velocity, the magnetic field around them increases, while the electrostatic charges decrease. This means during the acceleration of the particles, their mutual magnetic attraction increases, while the electrostatic repulsion decreases. By now, it isn't difficult to see what creates the illusion of an increase of mass with an increase in velocity, and the apparent vindication of Einstein. At speeds approaching that of light, ever larger clusters of particles become more tightly bound together by powerful magnetic fields. By this time, the electrostatic charge on the particles is practically non-existent, and the accelerating force, which is dependent upon charge of the particles, approaches the vanishing point. This seemed to support Relativity, because the particles can't exceed a certain limiting velocity. When all the electrostatic charge has been transformed into magnetic fields, the accelerating force dependent upon the charge becomes zero, and the particle cannot be accelerated any further. This limiting velocity will be shown in Part III to equal the velocity of light relative to its source.

The extremely heavy concentrations of magnetic fields, brought about by the particles being clustered together inside accelerators, requires the application of far more intense magnetic fields to hold the clusters in their circular paths inside the accelerators. It is a simple case of mathematics. It requires a certain magnetic flux to hold a single particle traveling at light velocity in the circular orbit. If the particles are evenly distributed in the accelerator, the flux or intensity required to hold all of them in orbit will be considerably less than if the particles become bunched up in groups. Requiring a more intense magnetic field gave the illusion of an increase in inertial mass of the individual particles.

It is indeed ironic that, according to Relativity, a material body cannot exceed the speed of light, as the particles in the accelerator seemed to indicate. This is false, as has already been indicated. It will be shown also in Part III that in spaceship propulsion an entirely different set of conditions exists, and it is possible for a material body to travel many times the speed of light.

Prior to the development of particle accelerators, the deflections of fast-moving particles in powerful magnetic and electrostatic fields

showed the decrease of charge with increase of velocity. It was found that the ratio,  $e/m$ , where  $e$  is the charge on the particle, and  $m$  is the mass, decreased with velocity and approached zero as the velocity neared that of light. Of course, relativists interpreted this as an indication of an increase of mass with velocity. Since mass does not increase with velocity, such experiments proved the charge on a particle is a variable, and decreases as the velocity increases.

The next fallacy of the Special Theory is the idea that the observed velocity of light is independent of the velocity of the source or that of the observer. There is no telling how often it has been disproved in laboratory experiments. At least one incident was given brief publicity about three decades ago. A naval research team photographed a spot of light moving across a cathode ray tube at a velocity of 202,000 miles/sec. The basis of this phenomenon was the interaction of particles moving about 16,000 miles/second. This is about the average velocity of the flow of electrons in the tube. This velocity, added to the velocity of light about "186,000 miles per second", produced the 202,000 miles per second. The results of this experiment were quickly hushed up and forgotten because it was an affront to something sacred. .

An ingenious experiment providing direct proof that this basic assumption of special Relativity is false was given no publicity. It is called the Saganac Experiment, and was performed in 1913. Two simultaneously emitted light signals were sent in opposite directions around a closed path, and a photographic plate was arranged to record the interference fringes at the place where the signals met. The apparatus from which the light source originated was supported on a turntable, which was free to rotate. The two light signals traveled identical distances, not along the turntable but the same distance along the surface of the Earth.

The turntable was given a spin with a rotational velocity of  $v$  relative to the Earth. The signal moving in the same direction in which the apparatus was turning had an initial velocity of  $(v \text{ plus } c)$  relative to the surface of the Earth, where  $c$  is the velocity of light relative to its source. The signal moving in opposite direction of rotation had a velocity  $(c \text{ minus } v)$ . If the basic premise of Relativity were valid, both signals would have traveled these equal distances along the surface of the Earth in identical times. They did not. The signal which initially traveled in the same direction of rotation reached the point where the camera was set up before the other signal. This pro-

duced the expected interference fringes. When the turntable was stationary, no interference fringes were produced.

It was evident, by the time this experiment was performed, the Special Theory was too deeply entrenched in the consciousness of the scientific community for such an eventuality to be tolerated. This is not surprising. It will be proven many times throughout this treatise that the scientific community is far more concerned about maintaining the status quo of science than in facing the truth.

Actually, there has been considerable indirect proof of the fallacy of the basic foundation of Relativity before and after the Saganac Experiment. The photo-electric effect of light shows that light is transmitted as particles, and not transverse waves.

This automatically accounts for the results of the Michelson-Morely Experiments. The particles of light which encounter no resistance in traveling through the ethers will have a velocity relative to the Earth, independent of the direction they travel. In other words, the observed velocity of the particles will be the same, regardless of the direction in which they may be moving away from their source. Additional evidence that light is propagated as particles and not waves is the fact that a beam of particles such as electrons, protons, and even molecules produce the same interference and diffraction effects as light.

To an individual versed in the elements of physics and the origin of the Relativity theory, such facts alone would be sufficient reason for him to reject the theory. But it has become painfully evident that orthodox physicists are not rational people. How did they react to such findings? They demonstrated once again their proficiency in doublethinking. They accepted both aspects, diametrically opposed to each other, and called it the dual nature of light. This dual nature supposedly causes light to behave both as waves and particles. This has also been called the "Wave Particle Paradox", because of the impossibility that a stream of particles would behave as transverse waves, of which light is supposed to consist. It will be clearly shown in Part III how a stream of particles can produce diffraction and interference effects. It will also become evident that such a demonstration is in accordance with other important principles, to be introduced in Parts II and III.

There is another incredible contradiction, which was mentioned earlier, inherent in the Special Theory that automatically invalidates it. Mass and energy are supposed to be equivalent and, therefore,



energy has inertia, according to Einstein. Photons of light are described as packets of energy traveling at light velocity. This is the same as a mass traveling at the velocity of light, which is supposed to be impossible. Relativists get around the dilemma by claiming photons have a rest mass of zero and can only travel at light velocity. When light passes through a medium, it slows down and consequently the photons travel at less than light velocity during this period. The assumption that anything which has momentum or kinetic energy has a rest mass of zero is a crass violation of the energy conservation law.

Besides the behavior of particles in accelerators, Einstein's disciples have cited other experimental props for the Special Theory. For example, a jet plane carrying a highly sophisticated atomic clock and traveling at 30,000 feet for 24 hours supposedly demonstrated the contention that time slows down on a moving system. After 24 hours, the clock lost 55 billionths of a second.

The result of this experiment involved a principle diametrically opposed to Relativity. When one body is given a velocity relative to another, a magnetic field develops around the former, as a result of its kinetic energy. This applies to a so-called uncharged body, as well as to a charged one. The reasons for this will appear in Part III. This magnetic field distinguishes it from the other body, and so it does matter which is considered the moving system. (As indicated earlier, physicists have partially come around to this way of thinking. The author suspects this is due to ideas he has been expounding for over two decades, which include this concept. Prior to this, the consensus was it did not matter which was considered the moving system. As mentioned earlier, the Lorentz equations make no distinction).

The magnetic field which resulted from the kinetic energy of the plane and everything moving with it, including the clock, although extremely minute, interfered with the moving parts of the clock and slowed down their action slightly.

Another experiment which allegedly confirmed the time dilation of moving bodies was the fact that high speed mesons last longer than those traveling at a lower velocity. So-called mesons are highly unstable particles and, after being created by artificial means, quickly disintegrate. The actual reason for this phenomenon should have been apparent to even the most obtuse physicist. The faster a particle travels, the stronger the magnetic field that develops around



it. The pinch effect of the magnetic field tends to hold the particle together. It follows that the faster the meson travels, the greater the tendency of the magnetic field to keep it from disintegrating.

One of the most incredible aspects of the odd thinking of relativists is that the Special Theory is actually based on the concept of an ether. Yet, Einstein and his colleagues rejected this concept. This is like sawing off a limb on which one is sitting.

By now, it should be thoroughly apparent to the reader, assuming he or she is not a doublethinking member of the scientific community, that the Special Theory of Relativity is completely devoid of substance. It has been established, as well as any truth can be, that the Special Theory is a ridiculous fantasy based on very bad logic, without a shred of experimental evidence to support it.

## **THE GENERAL THEORY**

The intelligent reader, whose sensibilities have been shocked by what has been revealed thus far, should brace himself before being exposed to the following analysis of the General Theory of Relativity. This theory is supposed to provide an insight into the nature of gravity and cosmology. One of the main foundations of the theory is the famous equivalence principle. It states that gravitational and inertial mass are equivalent. This idea is based in part upon the fact that the weight of a body is directly proportional to its inertial properties, and that the proportion is always a constant.

As expected, Einstein combined a fact with a fallacy, and ended up with a concept far removed from reality. For example, according to the equivalence principle, there is no way the occupants of a closed room could tell whether they were on a constantly accelerating spaceship or on the surface of a planet. The force holding them to the floor is supposed to be the same, regardless of whether it is the result of a gravitational pull or of being accelerated. According to Einstein, there is no experiment that could be performed which could show the difference.

Once again Einstein demonstrated a mental prowess that was less than acute. There are several experiments that could be performed to show the difference. If the room were on the surface of a planet, a sensitive gravity meter would show a difference in weight, if it were moved a short distance above the floor. On an accelerating space-

ship or elevator, there would obviously be no difference. This is the least significant test. A ball held up in the air and dropped would fall to the floor in identically the same manner, regardless of whether it was on the planet or the accelerating spaceship. However, there would be one essential difference. If this occurred on the surface of a planet, a steadily increasing magnetic field would develop around the ball, as it appeared to fall. If the ball were dropped on the spaceship, the ball would not be subjected to an acceleration as the floor moved up to contact the ball. Therefore, no additional magnetic field would develop around the ball while it was in the air. To render the argument even more convincing, it could be assumed the ball was heavily charged with electricity. In addition, a charged ball resting on the floor would develop a steadily increasing magnetic field if it were on the elevator or accelerating spaceship, since it would experience a steady increase in absolute velocity. Obviously, this wouldn't occur on the surface of a planet, since the accelerating force is directed toward the floor, preventing an increase in velocity. The specious arguments Einstein employed to establish the equivalence principle have been hailed as some of the greatest achievements in the history of human thought! Yet, it has just been proven that the equivalence principle is a fallacy based on inferior logic.

Einstein used the equivalence principle to derive another weird concept. It is the idea that a gravitating mass produces warps or curvature in the space around it. This is probably the origin of the idea of "space warps" used in science fiction and various illogical speculations. It does seem strange that something formless and without substance, and obviously independent of time, should possess some of the properties of matter and also time, as indicated by his term "space-time continuum".

According to this theory, when one body is attracted to another or vice versa, it follows certain warped lines in space.

It follows, according to this odd concept, that nothing can travel in a straight line. Straight lines do not exist and anything that moves, including light, goes along some space-warp line. Therefore, the universe is closed and shaped something like a cylinder.

By combining this idea of space warps with the Special Theory, Einstein was able to make certain cosmological determinations deviating only slightly from those of the Newtonian method. These "deviations" supposedly accounted for certain precise astronomical measurements which did not conform with those derived from

Newton's approach. Since it has already been shown that Newton missed the mark by a wide margin, it is not difficult to see what this fact alone does to Einstein.

According to Einstein, light from stars near the Sun's disc would be bent by the gravitational space warps produced by the Sun. (It has already been shown that gravity can in no way affect light or bend it, since gravity has been proven to be caused by electromagnetic radiations within a certain frequency range). He calculated the amount of light that would be bent by the Sun's field. This has been tested many times by eminent scientists during eclipses of the Sun, and they reported that Einstein's Theory has been confirmed almost exactly. This alleged vindication of Einstein has been the main factor in making his name a household word.

A closer examination of the facts reveals these reports were entirely misleading. Integrity has continually been proven not to be one of the scientific community's most redeeming qualities. These particular cases have done nothing to alter this viewpoint. Charles Fort provided evidence that the observation of eclipses did not confirm Einstein. The truth about this was inadvertently revealed in the May, 1959, issue of *Scientific American*, on pages 152 and 153. A diagram showing the stars' positions observed during the total eclipse of 1952 indicate the predicted positions of the stars, compared to the actual positions. It was admitted that changes in star positions agree only roughly with those predicted by the General Theory of Relativity. This was a gross understatement. At least one-third of them were displaced in a direction opposite to the one they were supposed to be! There were considerable variations in the extent of agreement for those that were displaced in the right direction. It is extremely significant that the stars closest to the Sun show the best agreement between observed shifts and predicted shifts.

There are three factors the scientists did not take into consideration during these tests. They are the atmospheres of the Sun, the Moon, and the Earth. Any one of these is sufficient to render the alleged confirmation invalid. Consider first the Earth's atmosphere. The refraction effect of our own atmosphere is variable and indeterminate. This makes precise astronomical measurements impossible. This has been thoroughly demonstrated by the errors made in the time and position of eclipses of the Sun, as mentioned earlier.

Charles Fort continually mentioned the difficulty astronomers have in making accurate determinations with only our own atmos-

phere to contend with. In the case of detecting the amount the stars are displaced during an eclipse, they also have the dense atmospheres of the Moon and Sun to consider. With all of this taken into consideration, a close to random displacement of stars further from the Sun's disc may be expected. This means that some of them will be displaced in the direction opposite to that in which they were supposed to be, as the diagram showed. For stars closer to the periphery of the Sun, where the atmospheres become progressively more dense, there should be a closer agreement with the calculated values. This is because light passing close to the Sun and Moon will have a greater tendency to be bent toward them by refraction. This pattern was confirmed by the diagram appearing in *Scientific American*, which actually disproved Einstein, instead of vindicating him.

Other alleged confirmations of General Relativity are even more ludicrous. Consider the case of the advance of the perihelion of Mercury's orbit. According to astronomers, the application of the Newtonian Concept of gravity to the calculated amount of the advance of the perihelion was off by 43 seconds of arc in one century from the true and observed amount. The General Theory allegedly accounted for this 43-second discrepancy! The degree of precision required to establish such a minute error is mind boggling. Remember, 43 seconds is only slightly more than one percent of one degree, and it requires over 400 orbits of Mercury, for even this amount of error to show up. There is a far greater margin for error in making such a determination, than in establishing time and position of eclipses. Their relatively big errors in this department have already been discussed.

This comedy of errors and delusion perpetrated by astronomers calls to mind a definition of astronomers given to the author while he was in grade school: "Wise men who study the stars." It seems some grade school teachers and writers of grad school textbooks had a great sense of humor even in those days.

Once again, the integrity of the scientific community is called to question. It seems they will go to any length to create the image of infallibility. The advance of the perihelion, if it exists, is completely unknown, if there is such a thing and another prop for Relativity has been dissolved.

Efforts to prove Einstein correct have been greatly accelerated in recent years with the development of more sophisticated devices. Instruments employing the Mossbauer Effect have allegedly con-

firmed the gravitational red shift predicted by Einstein. Light moving against a gravitational field will drop down in frequency, while light moving in the opposite direction will experience an increase in frequency. This seemed to be verified by directing gamma rays up a 75-foot tube and then down the tube. Gamma rays moving up the tube did seem to shift toward the red end of the spectrum, and when directed down the tube the shift was in the opposite direction.

Once again, physicists with their ignorance concerning the laws of nature have put the wrong interpretation on the results of their experiments. This experiment confirmed another kind of phenomenon far removed from Relativity. The Earth is being bombarded continuously by soft particles of all kinds from outer space, and these particles affect the passage of light. When the beam of gamma rays moved away from the Earth, it was moving against the stream. This tended to slow them down with an apparent drop in frequency. When they moved toward the Earth, they moved with the stream, and consequently, traveled at a higher velocity with the opposite effects. This will be explained in more detail after the nature of light and the properties of these soft particles have been thoroughly analyzed.

The slowing down of clocks on moving bodies, as predicted by Einstein, has been tested recently with Cesium clocks placed on commercial airliners traveling around the globe. It was believed a plane traveling east, or with the Earth's rotation, would lose time relative to a stationary Cesium clock. A clock traveling west would gain time relative to the same fixed clock. After traveling around the world in an easterly direction, the clock had lost 50-billionths of a second, while the one that had gone around the world traveling west had gained 160-billionths of a second. This was allegedly in close agreement with the prediction of Relativity.

It was assumed the real velocity of the plane traveling east was equal to its ground speed plus the velocity of rotation of the Earth. The fixed clock had a velocity equal to the rotational velocity of the Earth, while the one traveling west had an actual velocity equal to the rotational velocity, minus the ground speed in the westerly direction. By now, the intelligent reader knows the cause of these differences could not have involved the Relativity theory, and that one must look elsewhere for the causes. One does not have to look far. There are two factors that affect these clocks. One of them is the magnetic field developed by the kinetic energy imparted to the



clock. The other, and the greater factor in this particular case, is the concentration of the subtle energies or soft particles impregnating the mechanism of the clocks. These energies permeate all known space. The higher the concentration, the greater the tendency they have to affect the working parts of the mechanism. It is analogous to the friction of the atmosphere slowing down a moving projectile. A clock moving in the direction of rotation of the Earth will tend to capture or concentrate more of these particles throughout the moving parts of the clock than a stationary one. A clock moving in a direction opposite to that of the Earth's rotation will have a lower concentration than the other two clocks. Therefore, it will run faster than the others.

According to General Relativity, a gravitational field will tend to slow the passage of time. The stronger the field, the greater this tendency. It was found that Cesium clocks run faster at high elevations than those on the ground. This has been taken as another proof of the validity of Einstein's ideas. The concentration of soft particles is higher near the surface of the ground than at high elevations. (This will be shown later). It follows that clocks at high elevations should run faster than those at ground level.

Another alleged confirmation of Einstein that occurred recently demonstrated once again a complete lack of insight and common sense of present-day researchers trying to confirm Einstein. Bureau of Standards researchers, with new, elaborate devices, once more supposedly checked out the hypothesis that the velocity of light is independent of the velocity of the source or that of the observer. They found that light traveled as fast in the direction the Earth goes through space as it does in the opposite direction. The final conclusion, according to them, is "The speed of light is constant and Einstein's theory is right."

Incredibly, all phases of their experiment took place in the same reference system. All they showed was that the velocity of light relative to its source was independent of its direction of propagation, regardless of the velocity of the source. This is as it should be, and is what the Michelson-Morely Experiments actually indicated! Why didn't they revive the old Saganac Experiment of 1913 which provides direct proof that the observed velocity of light is dependent on the velocity of its source, and thus destroys Relativity?

A question that may come to the mind of the more discerning reader at this time is: since the bombardment of soft particles to the

Earth produced the red shift, why isn't the velocity of light affected by a change in the direction in which light is propagated on this Earth? A light ray traveling in the direction of rotation of the Earth or its direction of revolution about the Sun should encounter more soft particles, than when it travels in the opposite direction. The red shift noted was extremely minute and the degree of precision employed in such an experiment utilizing the Mossbauer effect was greater than in any experiment trying to confirm the constant light velocity hypothesis. Also, the velocity of the Earth in its orbit was small compared to the average velocity of bombardment of soft particles to the Earth. It was the high velocity of bombardment of these particles that made possible the detection of the red shift.

The reader has now been exposed to all of the essential facets, of what has been hailed as the highest achievement of the human mind, and the greatest advance toward our understanding of the universe, in the history of science. All of the universal accolades and reverence heaped upon Einstein have made the fact that his achievement was a fallacy based on superficial reasoning and very bad logic all the more incredible.

Einstein has had his detractors even in the scientific community. Amazingly, none either inside or outside this distinguished body has ever put his finger on the real flaws of this celebrated concept. Yet, as the reader has been shown, the contradictions and infantile logic have been apparent for many decades. Why hasn't it been accomplished before? Perhaps one of the reasons is that it was too obvious. People in general, and especially students of science, have been brainwashed into thinking that common sense rules don't apply in the higher realms of physics. Consequently, scientists get away with all kinds of irrational behavior. If an average citizen were to consistently display such fatuity in everyday affairs, he would be in danger of being picked up by men in white uniforms.

The concept of time has been so badly abused by Einstein and his disciples that a simple and obvious look at its true nature is in order. This will render the fallacies of the Relativity Concepts even more apparent. Time is simply another aspect of activity, motion, or dynamics in the guise of a symbol. It actually denotes the amount of activity in terms of a definite unit using space as a background, This makes possible the correlating of events and the bringing of order in the universe. The degree of motion is measured by this unit of time

such as for example, the distance covered by a body moving at a certain velocity. The higher the velocity the greater the distance covered. In other words time is the measure of what is accomplished by motion. This applies to every conceivable kind of activity. Obviously if all motion ceased time would no longer exist. It is merely a principle and consequently an intangible. It is consequently unaffected by anything that occurs in the universe. This, of course, includes gravity as proposed by Einstein.

This is all that it is. This means that, being an integral part of activity or motion of all forms, it is inseparable from them. Consequently, it cannot take on any of the weird properties attributed to it by a host of fuzzy thinkers, including Einstein, in their futile attempts to account for unusual phenomena beyond their comprehension. It is one of the great mysteries that such an obvious and simple concept has been overlooked. Yet, it is adequate to count for all of the supposed anomalies associated with time. This will be done in later chapters, when many of the strange occurrences which led to the delusions about time will be cleared up.

Scientists like Einstein have not been the only offenders in spreading misconceptions regarding the nature of time. Philosophers and metaphysicians are equally guilty. Readers in esoteric subjects are continually bombarded with prattle such as there is no time beyond time and space, etc. The definition just given to the readers renders the absurdities in such caprices more than obvious.

It is thus apparent that time would cease to exist if, and only if, all thought and all motion throughout the universe came to a halt. The slowing of the passage of time on a moving system is now seen to be self-contradictory. This concept treats time as an entity, separate from activity or dynamics. With the General Theory of Relativity, Einstein carried this absurdity to unbelievable lengths when he talked about a gravitation field warping time and space. This inanity no doubt spawned such mental crutches as "time warps" and "space warps" to account for anomalies beyond the understanding of present day theorists and speculators. Such terms have also become a popular tool of science-fiction writers. When one discusses "time warps" he is actually prating about energy or motion warps. Whatever that is supposed to mean has never been made clear.

Some readers may feel that too much space has been devoted to shooting down the Relativity Theories, when any one of the topics presented would have done the job. In other words, it has been a

case of overkill. As indicated earlier, the Einstein myth and the Special and General Theory will not die easily. These ideas have had, perhaps, a more stultifying influence on scientific thinking than any other theory. Such misconceptions have been clearly pointed out to leading scientists for many years. Instead of reacting as scientists are supposed to, according to the definition of the term "scientist", the scientific community has defended the old dogmas more vigorously than ever before. It seems they do not allow truth to stand in the way of such endeavors. Another indication that integrity is not one of their more noble attributes is given in an article entitled "Fraud Grows in Laboratories". It appeared in the June, 1977, issue of *Science Digest*. The article indicated that a high percentage of scientific data is falsified in order to make it conform with the results hoped for.

One can only speculate on how much of this was practiced during recent efforts to prove Einstein correct. There is another factor to consider concerning such tests, which require an amazing degree of precision. It has been shown repeatedly that the mind and thought forms can affect the behavior of various kinds of reactions. The phenomenon of telekinesis is not some science fiction writer's fantasy, as the scientific community would like to have the world believe. In any event, the experiments involving the Relativity Concept were not conducted with scientific detachment. There was always the great hope that Einstein would be vindicated. It is no stretch of the imagination to assume such strong desires did tip the delicate balance seemingly in favor of Einstein. Reports consistently stated the results agreed with the calculated values almost exactly.

The case against Relativity rests. It has been made clear that the Special Theory is based on the faulty interpretation of the Michelson-Morely Experiments, which were set up to detect ether drift. It was shown that the fact that light propagates as particles, not as transverse waves through an all pervading medium, violates the basic tenets of the theory. It was also proven that the brand of logic employed to establish the theory violated all the basic rules of rational thinking. The absurdities and impossible conditions derived from the foundation of the theory were rendered self-evident. The popular conception that the theory has a wealth of experimental evidence to support it has been thoroughly debunked.

The General Theory of Relativity has been as thoroughly confuted as the Special Theory. The famous Equivalence Principle, on which

the theory is largely based, has been proven to be false. The idea that gravity is produced by space warps has been shown to be a ridiculous fantasy. As with the Special Theory, it was established that there is not a shred of experimental evidence to support it and all of the alleged confirmations are explained in an infinitely more effective manner than with the General Theory. It is interesting to note the already experimentally proven fact that gravity is produced by a highly penetrating radiation in the electromagnetic spectrum completely demolishes the General Theory. Interestingly enough, well documented phenomena observed over the centuries also confutes the theory, such as levitation. If gravity were produced by space warps, there is no way levitation could take place. Even the levitating beams employed by UFOs and observed on many occasions could not work. The phenomenon of levitation will, of course, be explained later.

### **EINSTEIN'S INFLUENCE ON MODERN TRENDS OF COSMOLOGICAL THOUGHT**

UFO sightings suggest there is a possibility that extraterrestrial are among us. Evidently, this likelihood has finally come to the attention of some prominent physicists, after more than thirty years. According to their way of thinking, if UFOs are visiting us, they would have to come from other solar systems. This strongly suggests faster-than-light spaceships. Unfortunately, the Theory of Relativity stands in the way of this concept. Since academic theorists would renounce their own flesh and blood before they would Relativity, devious steps had to be taken to surmount the difficulty. One of the most distinguished among these physicists, John A. Wheeler, a devout Einstein disciple, came to the rescue with a theory which could permit faster-than-light spaceships without desecrating Relativity.

Wheeler was given high acclaim for this theory, an account of which appeared in *Saga* magazine in March, 1972. He gets around the difficulty with an extension of the General Theory of Relativity. Briefly, the Wheeler Theory contends that space is not only curved, but is shaped like a doughnut. It is supposed to be infested with "wormholes" which lead to a hyperspace, where time and space do not exist! UFOs allegedly come to us through some of the wormholes. Perhaps the reader may already be speculating as to where



these wormholes, if any, really do exist. Such an idea is stretching even irrationally beyond its elastic limits and enters the realm of hyperirrationality. How an object that occupies space can enter a region of no space and still exist has not been made clear. It seems that Wheeler has outdone his colleagues who are only skilled in the realm of doublethink.

This is an interesting study in the avenues a brainwashed individual of the academic world will take in order to retain a cherished concept that has been threatened. What is equally incredible is that such an idea has been taken seriously by many outside the scientific community. They look upon Wheeler as the man who will point the way to interstellar space travel.

Another outgrowth of Einstein's ideas that has gained considerable popularity and wide publicity is the concept of "Black Holes." Practically all of the leading scientists have jumped on the bandwagon and have added some of their own flavor to theories involving Black Holes. The concept of Black Holes has already been discussed briefly and completely debunked. The confuting of the General Theory of Relativity and the fact that gravity has no effect whatsoever on the propagation of light, automatically wipe out the Black Hole Concept. If Black Holes are a reality, there is only one place they could exist.

Another widely accepted concept is the Big Bang Theory. It is based on the idea that the universe originated from a giant explosion a few billion years ago. Everything has been flying outward and away from the center of this explosion. This supposedly accounts for the expanding universe, which has seemingly been confirmed by the famous red shift. The red shift is defined as an apparent doppler effect indicating that the more distant stars are receding from us at higher velocities. According to astronomical observations, more of the light from distant stars is shifted toward the red end of the spectrum. This and other phenomena, improperly interpreted by astrophysicists, will be cleared up for the first time later in this treatise. During the process, it will become evident that the Big Bang Theory is as devoid of sound thinking as the ideas already discussed. Such a thing is to be expected. The chief representatives of the scientific community have repeatedly shown that they are inept thinkers with an inability to look at more than one side of a problem.

One of the major stumbling blocks in academic thinking is the idea that natural phenomena are the result of chance and probability,

and not the effect of intelligent design. Causality is sinking into the background. Absolute materialism is the general theme. Judging by the quality of thinkers in the academic world this also is not surprising.

A broad and logical examination of the facts shows conclusively that there is intelligent design behind the operation of the universe. As the title suggests, it is what this treatise is all about. The vast majority accept this truth on faith alone. Since this fact does become obvious from any intelligent look at the world around us, it can be stated categorically that materialists, who constitute the bulk of the scientific community, as well as atheists and even agnostics, are all of very limited mental capacity. This will also become increasingly apparent in the pages to follow. Of course, this does not imply that nonmaterialists are necessarily brighter in many respects than the materialists. All it does is brand the materialists.

It may seem that Part I has been slanted too much in one direction by showing only the negative side of the world of science. This is the wrong impression. As mentioned previously, in order to pave the way for the introduction of vastly more fruitful ideas, it is mandatory to concentrate on this predominant side of conventional science and those who promulgate it and show a true perspective of it. For ages a greatly exaggerated and distorted version of the bright side has held the stage. The author admits that scarcely anything is all white or all black. There are nearly always the intermediate shades of gray.

In the interest of fair play, the author will attempt a brief and impartial look at the other side of the picture. The dedicated plodders of the scientific world do make discoveries that benefit the planet. This isn't necessarily accomplished by brilliant deductions, but by following tried and true procedures, or methods of research. Although the academic world has given us many discoveries that make life more enjoyable in some respects, they are also largely responsible for the suppression of better things than those they have contributed. Outside of the contributions they have made to society, the author has found, as Charles Fort did, a few aspects that could be considered praiseworthy. Perhaps the most admirable of these is their loyalty and steadfastness to an idea or an image. Although misdirected, it is real and is better established than was Fort's conclusion concerning the moral character of astronomers. Their unquenchable loyalty to Einstein and his ideas in the face of all odds is

touching. If this degree of fidelity were to be applied in other kinds of relationships, the world would be a utopia.

After considering the pros and cons, the composite picture of the scientific world emerging is not all black, although it appears to be in the darker and dirtier shades of gray. It differs somewhat from the beautiful portrait the world is accustomed to viewing.

Although the author has in some measure attempted to smooth over ruffled feelings that may have been created by previous comments on the merits of academic scientists, the gnawing suspicion he has done a miserable job of it persists.

Part I has been devoted to providing the highly touted theories of academic science and their vaunted claim of accuracy in the field of cosmology are false. It was shown that suppressed findings of the space program invalidate some of the most highly acclaimed ideas of conventional science. The Theory of Relativity was the main target discussed and it was proven, beyond any question, that it is a preposterous speculation based upon an atrocious brand of logic. It was also shown the alleged confirmations of the theory are a result of faulty interpretations of experimental data and superficial thinking. A dark cloud was also cast around the integrity of the scientific community.

The information and new ideas presented have paved the way for revealing some revolutionary insights in Part II. Additional evidence will be given that the Earth is hollow, as well as other surprising facts about the Earth and the universe. For the first time, an adequate explanation for tides, earthquakes, continental drift and other earthly phenomena will be introduced.

## **PART II**

# **THE NATURE OF FORCES THAT SHAPE GEOLOGIC HIS- TORY**

### **CHAPTER 3**

#### **THE CAUSE OF TIDES AND THE NATURE OF GRAVITY**

In order to understand the behavior of tides, an entirely new concept of the nature of gravity is needed. Gravity has always been the most baffling of all the common physical phenomena. So far, nothing even remotely resembling a satisfactory explanation for how it actually works has ever been advanced. A complete explanation will be forthcoming in Part III; but for the present, a broader look at gravity and directly related subjects will suffice.

The evidence is overwhelming that gravity is responsible for tides. However, the explanation in vogue since Newton's time is so inadequate that some cults believe gravity has nothing to do with tides. An analysis of the incredible flaws in the conventional explanation for tides will first be given before introducing the valid explanation.

One of the most extraordinary examples of irrationalism in the history of orthodox physics is the standard explanation of tides. In this case, the discrepancy between reality and orthodox speculation is so colossal it is one of the great enigmas in the history of human thought, that it has not been challenged since the time of Newton. The origin of the difficulty is an obvious flaw in the Newtonian concept of gravitation. It is the idea that gravity effects have unlimited penetration. In other words, there is no attenuation of gravity effects

other than that due to the inverse square law as it passes through matter. This is an outrageous violation of the law of conservation of energy.

It is indeed amazing this obvious fallacy has been the basis of nearly all astronomical calculations for about 300 years. This, of course, has led to many false conclusions in the field of cosmology, as will be shown later. Although this affront to common sense has been a gargantuan liability when applied to cosmology, it has created a travesty of impossible proportions where the explanation of tides is concerned. As every student of elementary mechanics is aware, a body cannot be give an acceleration relative to another, if the same acceleration is applied to each body. Therefore, it can be concluded that, since large bodies of water are accelerated relative to the Earth to produce tides, such bodies are given different accelerations than the Earth as a whole. Otherwise, there would be no movement of water across the surface of the Earth. It follows that the concept of unlimited penetration presents orthodox theorists with insurmountable difficulty in any attempt to understand tides.

Since the distances of the Moon and Sun are great compared to the diameter of the Earth, all parts of the Earth will experience very nearly the same gravitational attraction from these external bodies, if the above premise were valid. Any differences would be of an infinitesimal magnitude. High tides tend to occur when the Moon is approximately at its zenith and simultaneously on the opposite side of the Earth. This gave rise to the idea of tidal bulges, since the high water seemed to be almost directly below the Moon. The high water on the opposite side of the Earth presented the theorists with major technical difficulties. They surmounted the problem with nebulous discussions of centrifugal forces, horizontal components of the differential gravitational forces and other vagaries. The gibberish does not merit a reproduction. With such an impossible task facing them, the Newtonian advocates could do nothing else without abandoning Newton's concept, and that would be unthinkable. Interestingly enough a physics textbook left to posterity by the late and highly revered theoretical physicist, Richard Feynman, never deviated from this absurd explanation of tides. The shortcomings of the explanation are compounded by the fact that it contains an incredible contradiction.

It is stated that high water is not caused by any lifting of the water against the force of the Earth's gravity, but rather by horizontal



tractive forces unopposed by gravity. The horizontal component of already infinitesimal forces reduces them almost to the vanishing point. At the same time, the raising of water above the general level by an almost nonexistent horizontal force is in opposition to Earth gravity, which will tend to pull the "high" water back to the original level. It can be argued, of course, the horizontal components of Earth gravity are small compared to the vertical. However, it can be readily shown these components are far greater than any so-called tidal forces.

The Newtonian approach did seem to account for the annoying fact that the Moon is a far greater factor in producing tides than the Sun, but it created far worse problems than the one it seemed to solve. The plane of the Moon's orbit intersects the plane of the Earth's equator at about 28 degrees. This means that the Moon never wanders above 28 degrees north or south latitude. According to the standard theory, the greatest tides should all occur within this zone. Instead, the highest tides are experienced in much higher latitudes, both north and south.

To give the reader an idea of the minuteness of the tide producing force as based on the Newtonian concept, the following calculations are presented. According to conventional astrophysics, the Moon's average distance is about 239,000 miles from the Earth. Its surface gravity is supposed to be one-sixth that of the Earth or an ability to produce an acceleration of 5.36 ft./sec.<sup>2</sup>. The Moon's diameter, according to their findings is 2,160 miles. Since the force of gravity varies according to the inverse square law, the gravitational force the Moon would exert at the Earth's surface would be

$$5.36 \frac{1,080^2}{239,000^2} = .00013 \text{ ft./sec.}^2$$

Without considering horizontal components, the maximum total force could not exceed the difference between the force the Moon would exert at the Earth's surface and that exerted at the center of the Earth. This value turns out to be

$$.00013 - 5.36 \frac{1,080^2}{239,000^2} \text{ ft./sec.}^2 = .00002 \text{ ft./sec.}^2$$

This force is so minute that it would require 13.8 hours for it to accelerate any object to a velocity of one foot per second! It must be remembered, however, that the actual tide-producing force would only be a very small fraction of this amount. It should not be difficult for even the most obtuse mind to realize such a force could never even overcome the natural viscosity of the water. Yet it is supposed to produce tidal bulges and distort a solid Earth with an iron core 4,000 miles in diameter! Orthodox physicists are stuck with this monstrosity, since abandoning it would mean the collapse by the domino effect of everything they hold dear in the realm of theoretical physics. Their great skill in the realm of doublethink has

The position of point A in relation to the moon where the tidal force is a maximum

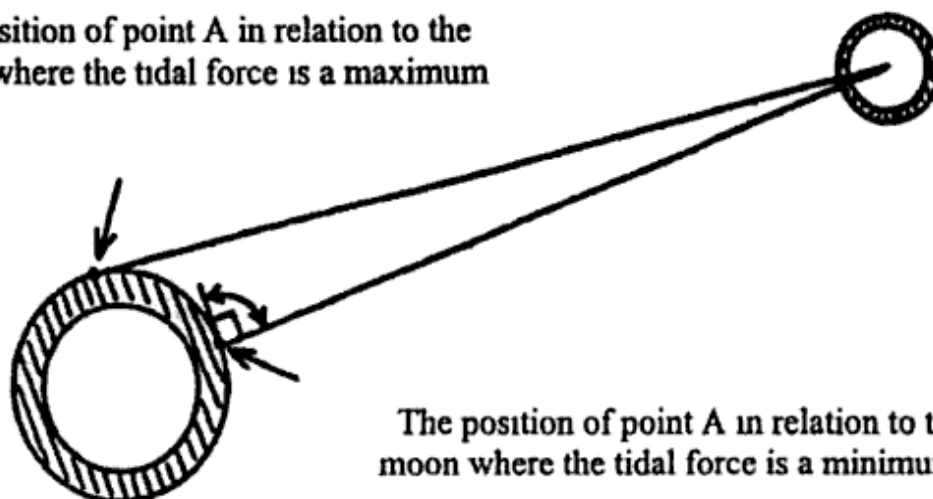

The position of point A in relation to the moon where the tidal force is a minimum.

**FIG 1: THE FORCES WHICH PRODUCE TIDES**

*It is the horizontal component of the Moon's gravitational pull on the Earth which produces tides. The same effect is also produced by the Sun. This results from the direct gravity radiations of both bodies which penetrate the Earth for very limited distance. The accelerating force imparted to the surface facing the source of the gravity-inducing radiations is far greater than the acceleration given to the Earth as a whole. Orthodox science assumes that gravitational force has an unlimited penetrating ability. Scientists are then forced to conclude that tides are the result of tidal bulges produced by the gravitational influence of the Moon and the Sun. However, the conventional theory cannot account for a force substantial enough to produce tidal bulges.*

enabled them to live with the contradictions inherent in this concept for the past 300 years. This case of mental ineptitude is only one of many others of similar proportions scattered throughout the realm of orthodox physics.

It is stretching credibility too far to assume that at least some of the brighter members of the scientific fraternity have not checked on tidal theory from a quantitative standpoint after all this time. If so, they would have noted the horrendous discrepancy. Since no mention has been made of it, the conclusion seems inescapable the experience was something akin to the opening of a Pandora box. Suppose one has observed an attractive but sealed box and wishes to learn what is inside it. As he loosens the lid the odors issuing from the box become so overpowering he is forced to clamp the lid back on as quickly as possible before his olfactory nerves are seriously damaged.

It is now apparent the idea of unlimited gravity penetration is not valid. This means the surface gravity effects of the Moon penetrate the Earth for only very limited distances. Therefore, the total acceleration the surface gravity of the Moon imparts on the Earth, as a whole, is very small compared to the acceleration force exerted on an object at the Earth's surface, such as a body of water facing the Moon. This means the water not being fixed to the Earth is free to move across the surface by means of the Moon's gravitational influence. The difference in gravitational accelerations is so great the acceleration given a body at the surface follows very closely the inverse square law, since the acceleration given the Earth as a whole can be disregarded.

For any given portion of a body of water, the horizontal component of the Moon's or Sun's gravitational pull will be greatest when such bodies are seen at the horizon. This is when the tide producing force is at its maximum. When either body is at the zenith or directly overhead, the tide-producing force drops to zero. As it passes the zenith position, it tends to accelerate the water in the opposite direction. This force reaches a maximum at the time the Moon or Sun begins to drop below the horizon. (See figure 1 and 2). The cause of two high and low tides during an approximate 24-hour cycle now becomes apparent.

Consider a western shore line. As the Moon, for example, rises above the horizon, a large mass of water is accelerated toward the

shore. This volume of water attains a significant momentum by the time the Moon reaches its zenith. The momentum is great enough to cause large quantities of water to back up on the land above the general level of the sea. As the Moon passes the zenith, it tends to accelerate the water in the opposite direction. The water soon loses its momentum in an easterly direction, and moves back away from the shore and acquires a similar momentum in a westerly direction by the time the Moon drops below the horizon. Both the Moon's accelerative force and the Earth's gravity moving the high water back to a lower level produce the movement toward the west. An oscillatory or wave motion of the water is produced. This causes another high and low tide before the Moon rises again.

The center of the mound of high water produced during a high tide will tend to lag behind the Moon as it moves across the sky. This is to be expected. Frictional forces and the fact that no acceleration is produced on water directly below the Moon cause a time lag. The mounds of high water in approximate positions below the Moon created the illusion of tidal bulges, especially since another mound of high water is produced on the opposite side of the Earth at the same time for reasons just given. The mounds of high water of

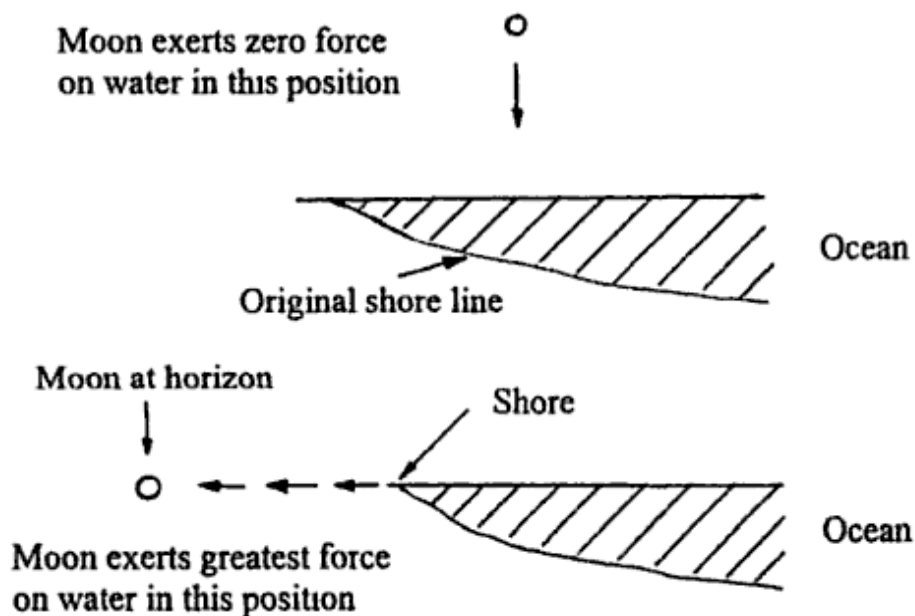

*FIG 2: FORCES MOON EXERTS ON WATER*

course, only occur on land. Otherwise there is only an ocean current.

The relative positions of the Moon and Sun, depth of the water and the shape of land masses affect the timing and magnitude of tides. The reason for the greater tides occurring in the higher latitudes becomes apparent from the analysis just given. Since the Moon doesn't stray more than 28 degrees above the equator, it is closer to the horizon most of the time in the high latitudes and thus exerts a higher average horizontal force on water masses.

As expected, the greatest tides will occur during a new Moon or when the gravitational influences of the Sun and Moon are both in the same direction. During the Moon's advance to the quarter position, the Sun works in opposition to the Moon for increasingly longer periods of time. This tendency reaches a maximum at the quarter moon. At this position, the Sun opposes the Moon at the maximum and assists the Moon during the rest of the time. This tendency for the Sun to oppose the Moon reaches a minimum when a full moon is attained. From this stage on, the Sun begins opposing the Moon. This reaches a maximum at the quarter moon. This tendency decreases as the moon moves to the last quarter, and finally to a new moon again.

It is now clear that this new approach to understanding tides easily accounts for all the basic facts concerning tides from a qualitative standpoint. It also explains tides from a quantitative aspect. In the analysis to follow, the effect of only the Moon will be considered and that the Moon is orbiting in the plane of the equator.

There is powerful evidence the surface gravity of the Moon is very nearly as great as Earth gravity. This possibility will be thoroughly explored and proven in Part III. However, to be ultra conservative, it will be assumed that Moon gravity is only 75 percent Earth gravity. It is also assumed that the Moon is orbiting at its closest approach which is supposed to be 220,000 miles. Therefore, the Moon's gravitational attraction,  $F$ , at the Earth's surface equals:

$$G_m \times 1,080^2/220,000^2 = .75(32.2)(1,080^2)/220,000^2 \text{ or } .000582 \text{ ft./sec.}^2$$

With this force, volumes of water will be given momentum toward a shore with the Moon behind it. This momentum reaches a maximum when the Moon reaches a maximum oblique angle with the water, at which time it will tend to accelerate the water in the opposite direction. Now assume that the Moon is orbiting in the equatorial plane of the Earth, and when it is at the zenith it no longer accelerates the water.



A calculation of the velocity the water attains may now be given. The acceleration at any time is,  $a = A \cos \theta$ , where  $A$  is the acceleration, at the time the Moon is at the horizon which has been shown to be about  $(.000582)$  ft/sec<sup>2</sup>. At this stage  $\theta = 0$ .

The velocity is most easily determined by finding the average acceleration over a six hour span, or from the time  $\theta$  increases from 0 to  $\Pi/2$ . This avoids troublesome integrations and manipulations. All that is necessary is to find the area under the curve  $A'$ , under the curve.

$$a = A \cos \theta \text{ from } \theta = 0 \text{ to } \theta = \Pi/2$$

$$A' = \int_{\theta=0}^{\theta=\pi/2} \cos \theta \, d\theta = -A (\sin \theta)_{\pi/2}^0 = A(\Pi/2)$$

If,  $a$ , had remained constant from  $\theta = 0$  to  $\theta = \Pi/2$ , this area would have been  $(\Pi/2)A$ . Therefore, the average acceleration =  $A/(\Pi/2) = .63A$  which equals  $.63 (.000582)$  ft/sec<sup>2</sup>. At the end of 6 hours the mass of water attains a velocity of about  $.63 \times 3,600 \times 6 (.000582)$  ft./sec. =  $.000366 \times 3600 \times 6$  ft/sec. or 7.9 ft/sec., which is more than 5 miles per hour. This is due only to the Moon effects at the equator where tidal effects are less. The value just obtained is of the same order of magnitude as the observed velocity of many currents. It is apparent this approach deals effectively with tides, both from a quantitative and qualitative standpoint. In the higher latitudes, the additional effects of the Sun, can create tidal currents much greater than 5 miles per hour. There are many factors which produce variations in tidal effects, such as the difference between a solar day and a lunar day, the shape or land masses, water depths, and latitude. This results in a very complicated tidal picture.

Tidal forces are largely responsible for ocean currents which, as is to be expected, are stronger in the higher latitudes. Tidal effects are not apparent in small bodies of water, since a large enough volume of water cannot be set into motion to offset frictional forces, and there is not enough time for much of the water to attain a significant velocity.

The analysis of tides presented above forms the basis for proving the surface gravity on the Moon is greater than that on the Sun. Since the Sun and the Moon have the same apparent diameters, viewed from the Earth, tidal effects produced by them are directly

proportional to their surface gravities. This will become evident from the following analysis: gravitational effects vary inversely as the square of the distance away. Their apparent diameters are inversely proportional to the distance; therefore, their apparent surface areas also vary inversely at the square of the distance. The gravitational effect of an external body on another is directly proportional to its surface area, therefore,

$$F_s \sim \frac{G_s A_s}{r_s^2} \quad \text{and} \quad F_m \sim \frac{G_m A_m}{r_m^2}$$

Where  $F_s$  and  $F_m$  are the tidal forces produced by the Sun and Moon,  $G_s$  and  $G_m$  are the surface gravities of the Sun and Moon;  $r_s$  and  $r_m$  and  $A_s$  and  $A_m$  are their respective distances and areas. Dividing, and given that their apparent diameters are the same, and substituting yields:

$$\frac{F_s}{F_m} \sim \frac{A_s r_m^2 G_s}{A_m r_s^2 G_m} \qquad \frac{A_s}{r_s^2} = \frac{A_m}{r_m^2}$$

$$\text{or } A_s r_m^2 = A_m r_s^2 \qquad \frac{F_s}{F_m} \sim \frac{G_s}{G_m}$$

Since the Moon is a greater factor in producing tides, the conclusion that the Moon has a greater surface gravity than the Sun is inescapable! To the orthodox mind this produces insurmountable paradoxes. The time has come for these to be resolved. This can only be accomplished by probing deeper into basic causes.

Much of what follows will be completely lost on some segments of the scientific community. Incredible as it may seem some honored members of the scientific world seem to be totally incapable of rational thought. Recently the author was astounded when one of these individuals, in fact an older brother in good standing, suggested that the author read the explanation of tides given in the *Encyclopedia Britannica!* Here is a classic example of the fact that many conventional scientists have and will continue to reject any reality that is damaging to that they hold sacred, regardless of how obvious and incontrovertibly true it may be. It will become increas-

ingly evident that few in the academic world are of sufficient stature to escape the intellectual straight jacket imposed on them by academic authority.

## CHAPTER 4

### **MORE ON THE NATURE OF GRAVITY AND DIRECTLY RELATED TOPICS WHICH INCLUDES THE NATURE OF LIGHT, SOFT PARTICLES, THE ETHERS AND HOW THE SUN HOLDS THE PLANETS IN ORBIT**

As mentioned previously, gravity effects are produced by a highly penetrating portion of the electromagnetic spectrum, which falls between the lowest fringes of the infrared and the higher frequencies of the radar band. It is in the order of about a trillion cycles per second. Most of the energy radiated by the Sun is in the ultraviolet range and above. Only an infinitesimal part of it is in the lower frequencies which contains the gravity radiations. Therefore, the Sun has a very low surface gravity as evident by the tidal effects it produces.

The law of redistribution of energy, not stated in any textbooks, plays a vital role in the benefits any planet receives from a sun. Briefly, it states that when radiant electromagnetic energy interacts with matter, the resulting radiation as a whole is of a lower frequency than the original light. The Raman effect, named after the physicist who discovered it, C. V. Raman, partly confirms this principle. Some of the aspects of the Raman effect seemed to violate this law when part of the resultant light was of a higher frequency than the original. This light was produced by triggering the release of higher energies in the atoms during Raman's experiments and was not a part of the original light.

The redistribution law is still only a special case of a more general law which states that energy, regardless of form, can only flow downhill or from a higher potential to a lower one. The famous second law of thermodynamics is a special case of this law.

The law of redistribution of energy accounts for temperatures at lower elevations being generally greater than at the higher altitudes. As the radiant energy from the Sun passes through the atmosphere, increasing portions of the light are transformed into lower frequencies such as infrared, which activates the thermal motion of atoms

and molecules, and produces heat. This process continues downward, even after the energy from the Sun reaches the surface. Before continuing with this phase of the discussion, another concept of paramount importance must be introduced.

For thousands of years, occult masters of the Far East have stated that all matter is comprised of light. They must have known what they were talking about, since the by-product of the transformation of matter into energy is light. Brilliant investigators such as Brunler and Reichenbach, whose work will be discussed in more detail later, have shown that light has a dual nature always overlooked by academic science. This duality consists of a visible portion, if in the visible range, and an invisible portion which is extremely penetrating. Reichenbach proved that it is this invisible part responsible for the effects of color therapy, since if light only bounced off the surface of an organism, it would have only minuscule effects on it. This penetrating and invisible part of light produces visible light when it disintegrates. It is safe to conclude from these considerations alone that when light is produced, particles comprised of this light are also created which accompany the light.

Since matter can produce light without the loss of matter, light must be a manifestation of something other than matter as defined. This manifestation is the much talked about but little understood ethers, permeating all known space. This is the stuff from which all matter is created and all things manifest. Many properties of the ethers can be deduced by application of the cause and effect relationship, and the Hermetic Axioms to be discussed later.

The ethers cannot be the rigid, inert medium pictured by many theorists. How can something inert manifest as life and intelligence? The ethers manifest life through a near infinite variety of particles, of which the most sluggish are far more active than the most active particles of physical matter. It will be shown in later pages that each particle of the ethers must consist of a universe within itself. Such particles may then be subdivided into other components. This process can continue to an infinite regression. It seems impossible to conceive of an ultimate beginning. One can only think of beginnings in terms of cycles. The term infinity has been used quite often by speculative thinkers, but its relationship to reality can only be applied by looking at the microcosm. When viewing the macrocosm, only the finite is seen.



The following principle must be kept in mind when examining the properties of the ethers: any dynamic unit is less active as a whole than the individual parts comprising it. Consider the fundamental particles of the atoms as an example. This principle is another outgrowth of the law mentioned earlier that energy can only flow from a high potential to a lower one. Growth of progression follows this same pattern, from the simple or more active to the complex or less active. The ethers must be thought of in the same manner. Therefore, there are what will be henceforth termed the higher and lower ethers. The higher ethers consist of the smaller and more active particles, while the lower ethers are comprised of the large, more complex and consequently less active particles. Both the higher and lower ethers occupy the same three dimensional space. Incidentally, this is the only space there is, in contradiction to the intellectual meanderings of many of the present day theorists. The ethers have a tendency to interpenetrate in a manner similar to the various frequencies of light. Space is permeated with electromagnetic radiations of all kinds which have little or no tendency to interfere with each other.

The ethers will be discussed in more depth and detail in Part III. This in-depth analysis is necessary in order to explain the seemingly inexplicable Fortean-like phenomena, and the science of psionics now considered beyond understanding. The picture just introduced will suffice for the remainder of this chapter.

When light of a given frequency range is produced, only the ethers associated with this light are directly activated. Light photons are comprised of combinations of ether particles. Photons combine to form the penetrating particles which accompany this light. Academic science has only recognized the existence of particles which comprise the atom and the artificial particles created in cloud chamber experiments. These artificial particles have nothing to do with the functioning of the atom, contrary to the beliefs of physicists. Their infinitesimal life spans should have told the physicists something. How could such unstable particles, with such fleeting life spans, play any role in the manifestation of stable matter. These physicists would deride anyone who suggested that the sound produced by water lashing against a rock was originally a constituent part of the water. Yet they apply identically the same kind of reasoning regarding these artificial and phantom particles to which they assign a weird assortment of names. During the high energy bombardments, the higher ethers are disturbed and corresponding pho-

tons are created. Some of these partially combine to form the very unstable particles.

Due to its more complex structure, soft protons are not as likely to be created during energy interactions as the much simpler soft electrons.

Particles comprised of light in the lower frequency ranges will henceforth be referred to as soft particles, while those associated with gamma rays and above will be known as hard particles. Hard particles always accompany gamma rays, because they are comprised of gamma ray photons. For light in the lower frequency ranges, it is the soft particles which accompany it and constitute the invisible and penetrating portion of light. The reason soft particles are more penetrating than the photons of which they are comprised will now be given. Photons have relatively great surface areas in proportion to their masses. When a myriad of them combine, the resultant particle has a relatively great mass in proportion to its surface area. To compare the relative penetrating ability of such a particle with a photon is like the comparison between a cannonball and a bird shot, when they are both traveling at the same velocity. If the velocity is high enough, the cannonball will pass through great thicknesses of matter, while the bird shot will only bounce off.

Soft particles, and particularly soft electrons, play a vital role in all of the life processes and other chemical reactions. The discovery of the concept of the soft electron was a major breakthrough. It makes possible simple explanations for a wide range of phenomena, including the occult, which would otherwise remain hopelessly unresolved. The effectiveness of this concept will be demonstrated as better explanations of how this planet functions are given.

The energy or field intensity of and around the higher ether particles is greater than that of the lower ethers. This is the reason the higher ethers are more active. Consequently, the field intensities around particles comprised of higher frequency photons are greater than those around softer particles. In fact, the field intensity around a given particle is directly proportional to the light frequency of which it is comprised. The diameter of a particle is inversely proportional to the average frequency of its constituent light. This can be deduced from the photoelectric effect to be discussed in Part III. The structural difference between positive and negative charges will also be shown in Part III, as well as the reasons like charges repel and unlike charges attract.

## **THE REASONS THE SUN HOLDS THE PLANETS IN ORBIT DESPITE ITS LOW SURFACE GRAVITY**

The visible photon radiation from the Sun is scattered and quickly dispersed or recombines to form soft particles, after it reaches the surface of the Earth. The soft particles continue on and penetrate below the surface. During this process, soft particles are continually breaking up with the formation of new particles, generally of a softer nature. Some of the photons released recombine with others to form new particles. At the same time, lower ethers are disturbed to form lower frequency photons from which softer particles result. This is in accordance with the law of redistribution of energy. Much of the disintegration of soft particles results from their encounters with other soft particles radiated in all directions from the atoms and molecules of matter. All matter radiates such particles continuously. This will be explained in more detail in Part III.

The energies radiated from the Sun are continuously transformed into ever lower frequencies, as they penetrate deeper into the Earth. In this manner, nearly all the original ultraviolet is transformed into lower frequency radiation by the time it penetrates the shell of the Earth. A direct confirmation of this transformation principle is evident from the relative brightness of the Sun at different elevations. For example, at the Dead Sea, the lowest depression on the surface of the Earth, the Sun is generally brighter than any other place on the Earth. In this locality, the Sun's radiations must pass through more atmosphere and therefore more ultraviolet is transformed into visible light. This is accentuated because the depression covers a considerable area. There is little difference in the brightness of the Sun when it is near the horizon and when it is at zenith, because of the wide scattering effects. A depression of large area concentrates more of the transformed radiations.

It is the transformation of some of the radiation from the Sun into gravity-inducing radiations which holds the Earth in its orbit. Only a very small portion of the radiations from the Sun are transformed into gravity radiations during their passage through the Earth, because of the high average frequency of the radiation. The amount is enough, however, to keep the Earth and the other planets in orbit

about the Sun and create the illusion that the Sun has about thirty times Earth gravity. It should be mentioned that soft particles penetrate solid matter more readily than hard particles, because they are associated with ethers which differ considerably from that of matter. Hard particles are, of course, an integral part of matter. This discrimination is analogous to waves of widely differing frequencies which have little effect on each other. It will be shown later that some of these soft particles radiated from the Sun are the "cosmic rays" academic scientists have been speculating about for the past several decades. Sufficient groundwork has now been laid for understanding the source of the high gravity of the Earth and Moon.

## **AN EXPLANATION FOR THE MAGNITUDES OF EARTH AND MOON GRAVITY**

All matter continuously radiates soft particles of many different kinds due to the interactions of the fundamental particles. These radiated particles undergo a transformation effect, according to the redistribution law, when passing through large concentrations of matter. When this occurs, some of the radiation is transformed into gravity-inducing radiations. This is the source of some of the Earth and Moon surface gravity. The greatest contributing factor to Earth and Moon gravity is the transformation of radiation resulting from the thermal agitation of atoms and molecules. The particles resulting from this activity are comprised of lower frequency photons. Such radiation is more readily transformed into gravity-inducing radiations, because it is closer to this frequency band to begin with. A significant portion of such radiation, originating miles below the surface, is transferred into gravity-producing energies by the time it reaches the surface. Most of the Earth and Moon gravity radiations are created in the first fifty miles of their crusts. Below that level, much of the energy from the Sun has been transformed into softer particles, and the material of the Earth and Moon is permeated with them.

These soft particles will screen out gravity radiations more effectively than solid matter, because the ethers they are associated with, are closer in frequency to those of the gravity radiations. The reason

Moon gravity is nearly equal to Earth gravity now becomes apparent. At the same time, it is clear why the famed Cavendish Experiment for determining the so-called gravitational constant was misleading. There wasn't enough material in the bodies used in the experiment to produce any transformation of radiations. The gravitational effects produced by the bodies were due entirely to the thermal agitation of the molecules without transformations. The thermal agitation of molecules produces infrared frequencies and only an infinitesimal portion of this radiated energy is in the gravity-producing frequency range.

The force the gravitating body used in the Cavendish Experiment exerted on the other body was the result of these same gravity radiations emanating from the body. The well-known gravitational constant was derived from the known mass of the gravitating body, and the force as exerted on the other body of known mass. This constant, and the idea of unlimited gravity penetration, required the Earth to have tremendous mass in order to account for the gravitational force it produces. Scientists assumed the Earth must have an iron core 4000 miles in diameter to account for such a mass.

It is significant that some of the Cavendish Experiments indicated gravity effects varied with the temperature. When the large gravitating sphere used in the experiments was heated, the attracted smaller sphere had a greater tendency to move toward the large sphere. When the larger sphere was cooled, the smaller sphere receded. This was explained away by convection currents, although they failed to explain how convection currents could produce such an effect. A detailed account of this can be found in the 11th edition of *Encyclopedia Britannica* within the subject "Gravity".

As mentioned before, matter produces infrared radiations which are partially transformed into gravity radiations. In the case of mountain ranges, there is not enough matter to transform significant portions of such radiations into the gravity radiations. Much of the radiation will escape from the tops and slopes of the mountains before they can be transformed since their average heights are generally small compared to their horizontal extension. The gravity radiations produced deep in the interior of the mountains are partially dispersed by the overlying mass. This is the cause of the plumb bob enigma, a source of annoyance to conventional physicists. The plumb bobs are not pulled out of line by the mountains to the extent the Newtonian law demands.



Another paradox emerges from the above presentation. The Earth radiates only an infinitesimal amount of radiation per unit of surface area in comparison to the Sun, but it is still able to hold the Moon in its present orbit about the Earth. This means the Earth is more dependent on the gravity radiations emanating directly from its surface to keep the Moon in its orbit. However, this isn't enough to account for the Earth's ability to keep the Moon in orbit. The Earth is radiating infrared in addition to the gravity radiations. This infrared is more easily transformed into gravity-producing radiations and is an important contributing factor. In spite of this, the Moon would still be much too massive to be held in its orbit if it had a shell as thick as the Earth's. The conclusion is that the hollow condition of the Moon is far more pronounced than the Earth's. This is supported by evidence supplied by the space program not given wide publicity. Seismic experiments produced strange reactions indicating an extremely hollow condition and even a metal shell! Some scientists speculated that the Moon was a giant, camouflaged spaceship. A very thin shell probably not over 100 miles in thickness could account for the possibility that Moon gravity may be slightly less than Earth gravity.

A critically thin shell accounts for the abnormal gravitational anomalies on the Moon noted since artificial satellites from the Earth first orbited it. In some areas, the increase in gravity was enough to drop the orbit as much as a kilometer during a single revolution. The following passage relating to this subject is taken from an article in the *Saturday Review*, June 7, 1969 on page 48: *Periwiggles continued to betray orbit irregularities 1000 times the size of those expected from lunar gravity theory.*

The kind of explanation from physicists for such discrepancies is completely predictable. Large chunks of nickel and iron must be buried in the Moon's crust. They have been called mascons and some of them must be as much as 100 kilometers in diameter to account for the gravitational anomalies. They supposedly bombarded the Moon in the distant past and are imbedded a relatively short distance below the surface.

This deduction must give way to one which is in conformity with the principles already outlined. Apparently, the Moon's shell is relatively thin; hence variations of just a few miles in the thickness over extended areas would result in very noticeable differences in its surface gravity, enough in fact, to produce the observed differences.

Such large variations do not exist on the Earth because of the overall thickness of the Earth's shell which must be about eight times as great as that of the Moon. The slight variations which do exist over and above those caused by the centrifugal force of the Earth's rotation, are probably due largely to the effects of underground caverns. It may be shocking to some readers to realize that a solid ball less than 150 miles in diameter would have a surface gravity approximately that of the Earth, and that many of the asteroids have Earth gravity.

Recent findings by astronomers and astrophysicists indicate that this is indeed the case. The scientists were shocked during 1978 and later when they discovered that some of the asteroids have moons that revolve about them at a respectable velocity. According to Newtonian concepts, this should be impossible since the gravity effects of the asteroid would be much too feeble. It is understandable why this monumental finding has not been given much publicity. Nevertheless, the truth has the habit of rearing its ugly head when least wanted and expected. An account of this interesting discovery was revealed over radio Station KCRL, Reno, Nevada on the evening of January 20, 1981.

At this stage it may be advantageous to show how the gravity effects around a body changes with the size and mass starting with a small body of laboratory dimensions. It will also promote a better understanding of the plumb bob enigma. Within certain limits the gravity effects will be directly proportional to the mass as the size and mass increases with only very slight deviations. As the mass and size continues to increase the outer gravity effects will for a certain increase, become less per unit mass than that of a smaller mass because the screening effect of the outer layers will more than compensate for the amount of infrared radiations. (The screening effect is produced largely by soft particles which permeate all matter and will be discussed and analyzed in more detail later). This tendency will continue until the body reaches a diameter of several miles. This is the main reason for the plumb bob enigma. Beyond this stage the body becomes large enough for a significant proportion of infrared produced within the body to be transformed into gravity radiations. From this point onward the gravity effects will increase rapidly with increase in size since far more infrared is transformed than is screened out by the outer layers of mass.

This tendency will continue until the body becomes about 150 miles in diameter. Beyond this size there would be scarcely any increase in surface gravity as the size increases. The outer layers become thick enough such that the screening effect keeps pace with the rate of increase of the transformation of infrared into gravity radiations. This means that all planets have practically the same surface gravity.

It now becomes clear why all planets are hollow. If they were solid with iron cores the Sun couldn't hold them in their orbit with the present orbital velocities. The Sun's gravity effects couldn't penetrate such bodies deep enough.

## **CHAPTER 5**

### **THE CAUSE OF EARTH UPHEAVALS, CONTINENTAL DRIFT, EARTHQUAKES AND VOLCANOES**

Geologists and geophysicists are a bit vague when they discuss the forces producing earth upheavals and the folding of strata to produce mountain ranges. Their explanations for the forces causing continental drift are equally tenuous, if they exist at all. This is understandable since they are dealing with phenomena completely beyond the scope of present day theoretical physicists. It is apparent that tremendous tensional and lateral forces are involved. There are high concentrations of primarily soft, negative particles in adjacent strata and fault lines. It will be shown in Part III that soft particles are impregnated with harder particles whose presence is not apparent, due to the camouflaging and mitigating effects of the softer particles. When soft particles penetrate matter, they carry hard particles with them. When soft particles disintegrate, the hard particles are released. Therefore, most of the great forces inside the Earth's crust are the result of released hard particles.

The concentration of negative charges, resulting from the penetration of soft particles from the Sun, and the radiation of the matter inside the Earth combine to produce tensional forces. Such forces at work in the Earth's crust cause fractures and the sliding and folding of strata over each other. The gravitational forces holding the Earth in its orbit also produce stresses in the crust, adding to these lateral forces and is perhaps the greatest factor in this phenomenon. Since the gravitational effects of the Sun are not uniform throughout the Earth due to limited penetration, enormous stresses in various areas of the shell are the result.

If the Earth were a completely solid ball and the Newtonian version of gravity were correct, the Earth would be completely rigid and no Earth changes could ever occur with the exception of minor erosion. There would certainly be no mountains left by now. The

frictional forces along plates and strata would be so colossal that no sliding could ever occur. A major factor responsible for sliding is the tremendous repulsive electrostatic forces. They result from the concentrations of soft particles and their disintegration along plates and faults acting like condensers for soft particles. The sliding tendency is expedited because the gravity effects are considerably weakened at those depths. The orgone concentrations are so great due to back-up of particles from the Sun. That relatively thin layer can screen out nearly all gravity radiations from all directions. If it were not for this screening effect pressures would steadily increase with depth despite cancellation of gravity effects. If the particles were all comprised of the same frequency photons, the concentrations would not be nearly as great. When there is a great range of frequencies involved, far greater concentrations can result. Particles differing greatly in the photons of which they are comprised tend to interpenetrate. The repulsive forces are therefore correspondingly higher.

The evidence for continental drift is overwhelming. This idea does not seem to be in conflict with conventional beliefs; hence, it is universally accepted by the scientific world. The electrostatic forces and stresses produced by the Sun's influence, just discussed, make continental drift possible; and are a greater factor than gravitational pull in producing Earth changes. Continental drift indicates the Earth is slowly expanding.

Since a hollow sphere cannot expand in this manner without creating major breaks or openings in the shell at approximate antipodes, the origin of the large egresses into its interior is explained. In addition, the sliding of plates over each other no doubt produced the large caverns which honeycomb the Earth's shell. It should also be noted that if the Newtonian concept of gravity were valid, the enormous pressures at such depths would produce cold welds resulting in a totally solid Earth with no plates. The pressures would steadily increase with depth until the center was reached. It should also be noted that if the concepts introduced above were not valid, high temperatures inside the Earth could not exist, the Earth would be a cold body from the surface to its center.

A major objection to the existence of giant caverns deep inside the Earth covering millions of square miles, is the roofs should collapse, even in low gravity. The high concentrations of combinations of soft particles inside these caverns screen out gravity radiations far more



effectively than solid matter. Therefore, the roofs of these caverns have little or no gravity affecting them.

The expansion of the Earth and continental drift are helped along by the gravitational pull of the Sun. The gravitational force due to the Sun varies throughout the Earth's shell. This creates tremendous stresses increasing the tendency for plates to slide over each other. The origin of earthquakes is now apparent. There are times when the concentration of charges reaches a critical state. A condenserlike discharge of particles then occurs. The sudden discharge of hard electrons when this happens produces an explosion. Since the hard particles are partially confined, tremendous forces are released causing the Earth to shake. A similar phenomenon produces lightning. Many of the discharged particles find their way back to the surface. Some of them break up into their constituent photons and thereby produce color effects sometimes preceding a quake. Animals and sensitive people can sense these energies. These discharges could be a means for predicting earthquakes.

Prior to a quake the discharge of soft particles will cause an increase in temperature of strata far below the surface. As the particles move to the surface, many of them disintegrate and release large quantities of hard electrons. This process will be relatively slow at first; but as the temperature increases, larger quantities will disintegrate with also a consequent increase in the rate of discharge. Consequently, the rise in temperature of lower strata prior to a quake will be slow at first, followed by a rapid increase in temperature.

## THE ORIGIN OF VOLCANOES

The academic explanation for volcanic activity is somewhat vague. Since the temperature of molten lava disgorged by volcanoes is so great, the orthodox viewpoint is the molten lava would have to originate at levels hundreds of miles below the surface. It has not been made clear how lava could find its way to the surface from such depths, since the Earth is supposedly a solid ball.

Mine shafts and oil drilling operations have indicated significant increases of temperature with depth. This phenomenon is a result of two factors, the law of redistribution of energy and the disintegration of soft particles. It has already been shown the redistribution law is

responsible for the higher temperatures at lower elevations. This process continues as the radiation from the Sun penetrates the Earth's crust. The lower frequencies are readily transformed into infrared radiations which produce increases in temperature. The temperature gradient in the first few miles below the surface is reasonably steep. This temperature increase practically ceases after several miles of penetration. The more unstable particles radiated by the Sun have disintegrated by the time they reach this level. The temperature decreases slightly from this point downward. The disintegration of soft particles, with the consequent release of energy, and hard electrons, is an important factor in the temperature increase. Most of the soft particles that disintegrate during this interval are comprised of photons below the visible range of the electromagnetic spectrum.

The more stable, higher frequency particles remain after several miles of penetration. Consequently, disintegrations become less frequent and lower intensities of infrared are produced and also fewer hard electrons are released. As a result, the temperatures in the caverns are maintained at a comfortable and constant level. The desirable temperatures experienced deep inside the Earth have been mentioned in various accounts, including the *Etidorhpa* book.

Since volcanic activity is not a result of uniformly high temperatures deep inside the Earth, one must look elsewhere for the cause. According to *Etidorhpa*, (a book to be discussed in the next chapter), most volcanic activity is due to vast deposits of sodium in certain regions of the Earth's crust. Large quantities of water periodically reach some of these deposits at great depths. The shifting of plates and fault lines opens fissures allowing water to reach them. The contact of water with sodium results in great temperatures and pressures, and melted rock is then forced through these fissures to the surface.

*Etidorhpa* implied that some volcanic activity is produced by other means. The build-up of ultrahigh concentrations of radiated particles from the Sun in certain portions of the Earth's crust, could cause the temperature increases necessary to produce molten rock. Faults and areas between plates in the crust act like great condensers for accumulating large quantities of hard electrons. The presence of these electrons greatly increases the temperatures of the surrounding rock. This results in the disintegration of increasing numbers of soft particles and the subsequent release of more hard electrons. The released

hard electrons have little chance of readily escaping from the region, and the temperature of the rock steadily increases until it is well beyond the melting point. There is usually water present during the process. The superheated steam, mixed with the molten rock, enables it to be expelled to the surface with explosive violence.

It is interesting to note that if the cooled down lava is reheated to temperatures far above that of the original molten lava, it will not melt. This has never been explained. The high concentrations of soft particles permeating the rocks, in conjunction with the superheated steam which adds to this concentration, lowers the melting point to a considerable extent. All of the excess particles have escaped or disintegrated by the time the lava cools, and the melting point is consequently higher.

It is extremely significant that most of the large earthquakes occur in the regions of present or past volcanic activity. This is another indication that high concentrations and disintegrations of soft particles play an important role in volcanic phenomena. It has already been shown that fault lines promote high concentrations of soft particles.

There is strong evidence that volcanic activity has been decreasing down through the ages. This adds support to the causes of such phenomena presented in this chapter. If deposits of sodium and radioactive materials are the basic cause, then, as these deposits are depleted, volcanic activity will decrease.

## CHAPTER 6

### THE HOLLOW CONDITION OF THE EARTH

As mentioned in Part I, some of the pictures of the Earth taken from satellites and the Moon have indicated a large egress into the hollow interior of the Earth. It is located just south of the North Pole in northern Canada. This, of course, is only a small part of the evidence of a large entrance into the Earth.

Arctic regions well above the Arctic Circle periodically experience a fall of red pollen which discolors the snow. Some species of birds in the higher latitudes migrate north instead of south during the fall. Warm north winds often occur in these areas. Also, large quantities of driftwood are found along shores in the far north that couldn't have come from the forest trees of the south. The ocean currents are in the wrong direction. There are indications that some of the driftwood came from large trees. Trees of comparable size only exist in the temperate regions of the outer Earth. Icebergs in the North Atlantic are comprised of fresh water. This means they were not formed from ocean water. If so, they would contain large quantities of salt. The driftwood and the icebergs suggest that a great river flows out of the opening, carrying driftwood with it and freezing, as it enters the outer Earth to form the icebergs.

Such a large opening clears up the discrepancies in Admiral Peary's alleged trek to the North Pole. Leading explorers of the day seriously doubted the validity of Peary's claims. Even the U. S. Navy had serious doubts. To prevent a scandal which would cast a cloud over the service, he was officially given credit for reaching the pole. Interestingly enough, the route taken by Peary intersected the lip of the opening shown by the satellite pictures. The later stages of Peary's trek showed daily increases in latitude that indicated mileages impossible to cover by dog-sled over the kind of terrain that exists in the area. In fact, even under ideal conditions, such mileages would have set new records for travel by dog-sled during a 24-hour period. As Peary entered the region of the opening, the curvature of the Earth would rapidly increase and his instruments would have

greatly exaggerated the degree of latitude attained. Finally, there would have been an indication of 90 degrees latitude while he was still far from the actual pole.

The personal experiences of a close friend of the author confirmed the existence of this opening. He was in the U.S. Air Force and stationed in Alaska during and after World War II. He did much aerial mapping for the government in this area after the War. It was found the maps produced would not fit on a globe. There was a lot of overlapping. He also noticed the Sun wouldn't drop much closer to the horizon than it should have during some of his flights. Shortly afterwards radar stations were set up across Canada to allegedly warn of possible Russian attacks. This is another of the lies of officialdom. The real purpose was to keep planes out of this area. Those that continued too close were turned back.

The Earth and other planets are hollow from logical and theoretical considerations. Since electromagnetic radiations, including those in the gravity-inducing range, have limited penetration, it follows that they, the planets, could not remain in their present orbits at their present orbital speeds if they were the solid balls academic science claims. Even a hollow Earth would be too massive if its shell were solid and not honeycombed with the vast caverns it possesses. The satellite pictures of the Earth, including the view described in Part I showing the flat in its outline provide a clue for estimating the thickness of the shell. The flat is about 1600 miles across and the actual hole seems to be about 600 miles in diameter. If the curvature around the lip is uniform, then the shell must be about 1,000 miles thick.

The planets are hollow from a still more logical standpoint. They were created by intelligent planning to support life and for the progression of various life forms. It follows they would be designed or engineered for the most efficient operation. A hollow planet with caverns throughout its shell could support many times the amount of life, since it would have many times the surface area available than would a solid planet. More important yet, such a planet could be maneuvered into various positions (as they are at times) far more readily than if they were solid. The Logos, who created the planets are, of course, far more intelligent than any human. Therefore, they would not be so stupid as to produce solid balls, for planets, as an academic scientist would if he possessed the power to create a planet. They utilize every scrap of material. The changing of the



position of planets by space ships with giant levitating beams will be discussed in Part III. This accounts for great changes in the Earth through the ages, including the great flood and other cataclysms.

A description of a hypothetical trip into the interior of the Earth by means of a tunnel will now be given in order that the reader may better understand what the Earth's interior is like. After descending below the five-mile depth, the traveler will begin to notice a rapid decrease in his weight.

This is because of the limited, penetrating ability of the gravity radiations and the gravity effects of the Earth above counteracting the gravity effects of the Earth below. These counteracting effects are enhanced by the mass of Earth above, tending to transform some of the infrared radiations emanated by this matter into the gravity-producing radiations, according to the redistribution law.

One will begin to notice the darkness tending to diminish after about ten miles. This is due to some of the soft particles radiated from the Sun which begin to disintegrate into their constituent light, after passing through several miles of solid matter. The deeper one goes, the lighter it becomes, since ever larger quantities of these highly penetrating particles from the Sun are disintegrating into light. The less stable particles disintegrated during passage through the atmosphere. After a considerable distance, the traveler will notice a significant improvement in his physical strength and vigor. This is due to the higher concentration of beneficial particles found at these depths. It should be noted that the bulk of the particles disintegrating earlier, in the descent produce the initial temperature increases, are in the frequency ranges below the visible orange. Consequently one experiences only darkness at the upper levels.

There are no shadows in the lighted portion of the Earth's interior, because the light comes from all directions, instead of from a central source. Plant and animal life flourish in the deeper caverns and are larger than on the surface, because of the higher concentrations of soft particles, and the almost complete absence of soft particles, comprised of light, in the higher ranges of the ultraviolet, as well as the lower gravity experienced at these depths. The traveler will enter the zone of zero gravity relatively close to the surface of the inner shell. This is where the gravity effects toward the surface of the Earth exactly counteract the gravity effects from the opposite direction. This inner shell of the Earth is finally reached after approximately 150 additional miles of travel.

In the inner Earth, the traveler will see a glowing ball of light called the "central sun", located at the Earth's geometric center. It consists of a high concentration of soft electrons. The reader no doubt wonders why it is there. A high gravity exists at the surface of the inner shell, because the countergravity effects from the upper half of the shell are screened out by the high concentration of soft particles in the space between. Negative charges tend to be repelled by a gravitational field, in direct contradiction to concepts of academic science. Positive charges are attracted by the field. This will be explained in Part III. It will also be shown that ordinary, supposedly uncharged, matter behaves like a positive charge. In view of this, the reason for the concentration of soft electrons at the center forming this glowing ball becomes apparent. The particles have their greatest concentration at the center because they are repelled by the gravitational field on all sides. The light is produced by the continuous disintegration of particles, due to their interactions. They represent the excess of negative charges from the Sun reaching the inner shell of the Earth.

Recent findings of satellites confirm the existence of this central sun and especially the existence of a large opening into the Earth's interior in the north polar region. Photographs released show the Earth topped by a glowing halo, hovering about 60 miles above the icecap. According to the reports, satellite pictures in the past have shown a partial halo, but recent photos show the ring in its entirety "making the Earth look as if someone placed a white wreath around the North Pole."

From an orthodox standpoint there is no way this ring effect can logically be explained and all attempts have been devoid of sound thinking. From what has just been presented, the explanation is obvious. The central sun would naturally radiate high concentrations of soft electrons in all directions. Those whose paths take them close to the edge of the opening will encounter much of the Earth's atmosphere. Many of these will tend to disintegrate as they pass through the atmosphere. Most of these disintegrations will occur some distance above the Earth's surface as they leave the opening. Those whose paths are further from the edge, including the center, will encounter little or no atmosphere, and thus travel to outer space without disintegrating. A ring effect is the result. Although this ring is close to the North Pole, it could not be centered there, but must be offset a few hundred miles, since previous satellite pictures show

this opening to be in the vicinity of the magnetic pole in northern Canada.

The diameter of the ring will fluctuate. It will vary from approximately the diameter of the opening, to several thousand miles. The particles which hit the atmosphere, when ejected from the openings will usually travel considerable distance beyond the opening, before many of them disintegrate into their constituent light. This distance will vary according to their concentration, and the velocity at which they are ejected. They are forced outward in all directions by a continuous flow of particles from the interior. Resistance produced by the atmosphere and the particles it already contains, tends to slow them down. This causes a backup of particles. The backup of particles will often concentrate close to the lip of the opening during periods of normal solar activity, when the velocity of particles ejected from the interior is relatively low. The resultant disintegration of particles will produce a ring approximately the diameter of the opening. It has been found that during this period, the rings measure 600-700 miles across. Interestingly enough, a close examination of early satellite pictures indicate that the north polar opening is about 600 miles in diameter. Since the above-mentioned flat in the outline of the Earth is about 1,600 miles or more across, it can be concluded that the Earth's shell is about 1,000 miles thick!

It is interesting to note how our obtuse physicists account for the above phenomenon. They claim to have located a huge egg-shaped power source, that helps create the northern and southern lights. The "power source" is allegedly an invisible zone, 30-40 times the size of Earth, located about 400,000 miles distance, always on the side of the Earth away from the Sun. It uses magnetic forces to trap electrically charged particles from the "Solar Wind." Supposedly, satellite photos of the most detailed ultra violet and visible light of the northern and southern lights, allowed these "ingenious" individuals to calculate the location of the power source in the Earth's magnetic "tail." The tail is supposedly, the 4-million mile long part of the Earth's magnetic field, blown away by the solar wind.

They are candid enough to admit the photos do not actually show the power supply that created the lights, but by studying the photographed variations in the light, physicists were allegedly able to calculate its location and they were also a bit vague as to the nature of this phantom "power source," and why it has to be always on the side of Earth away from the Sun. Often, in their futile attempts to

explain away certain phenomena, they drag in a monstrosity that poses a greater mystery than the one they are trying to explain away.

The diameter of the ring becomes greater during auroral displays. This is the result of greater discharges from the Sun which penetrate the Earth's shell in greater numbers. A higher rate of particle accumulation at the Earth's center will result, with a consequent higher radiation through the openings. The particles reaching the atmosphere around the lip of the opening have a higher velocity than before. This increased activity causes the more unstable particles to disintegrate before they leave the opening. Consequently, the more stable particles remaining will travel a greater distance before disintegrating.

The cause of the auroras becomes self-evident. The increased concentration of soft electrons radiated from the openings as a result of increased sunspot activity produces a higher percentage of soft particle disintegration in the upper atmosphere.

The author predicts that a halo effect will also be found in the Antarctic region. This will be in the south magnetic polar region south of Australia. More recent satellite photos have confirmed the author's prediction.

If it were not for the large entrances into the Earth's interior, all life in the inner Earth, including the great caverns, would be obliterated. The excess particles radiated by the so-called central sun would accumulate in increasing numbers through the Earth's crust. There would be an ever increasing number of soft electrons disintegrating and releasing ever greater quantities of hard electrons, causing a steady increase in temperature through the inner Earth. It would be something akin to the greenhouse effect. A smaller body with a much thinner shell, like the Moon, does not require large egresses. Most of the excess particles can escape back through the relatively thin shell without disintegrating. (Recent determinations indicate the Moon is much larger than is claimed). The particle accumulation in the interior will thereby be much less. It is highly significant that a picture of the planet Venus' surface taken recently by Pioneer orbiter shows unmistakable evidence of a great egress into the planet's interior. It has a diameter about one-fourth that of the planet itself! This picture is shown in color in the September, 1982 issue of *Science Digest*.

Later pictures which appeared in the November-December, 1982 issue of *Planetary Report*, showing a series of pictures covering the

entire surface and taken by the Venus Orbiter, display the other opening, which is just about the exact antipode of the former. This one is a much larger and has a diameter about 40% that of Venus. This is to be expected. Venus receives far more intense radiation than the Earth and requires much larger openings in order to prevent excessive heat build-up. These openings look like round shallow craters. This illusion is due to the ultra high concentration of soft particles at the entrance which tend to reflect external light and thus give the appearance, of a relatively shallow crater with a large diameter. In view of the obtuse minds prevalent in the scientific community it is not surprising they were explained away as impact craters. It should be obvious to even the less gifted members of society that a missile capable of producing a crater of such a diameter would shatter even a solid planet, another existing at the antipode greatly compounds the enigma.

A further analysis of gravity conditions to be expected along this hypothetical tunnel, leading from the Earth's surface to the concave inner shell, is in order. The gravitational force produced by a large body such as the Earth or Moon is the result of the transformation of radiations from matter of a higher frequency than the gravity-inducing radiations. Some of it comes from the radiation produced by the interactions of the fundamental particles. However, most of this radiation has such a high frequency that only a very minute percentage is transformed into gravity radiations. Therefore, most of the gravity produced is due to the transformation of lower frequencies resulting from the thermal agitation of atoms and molecules. These radiations are mostly in the infrared range, not far removed from the gravity range. This means that such radiation, or the soft electrons associated with it, does not have to travel great distances through matter, without significant portions of it being transformed into gravity-producing radiations.

The concentration of soft particles radiated from the Sun begins to increase significantly after a few miles below the surface. This is due to a steady retardation of their passage through the Earth and the resulting back-up of particles. The increased concentration diminishes after a time, and the concentration gradient becomes smaller from about the halfway point to the inner shell. The pattern of the gravitational attenuation gradient can be easily deduced from this picture. After only a very few miles below the Earth, gravity begins to diminish rapidly. This is because the mass of Earth above is be-



ginning to transform significant portions of the infrared radiations emanating from the matter into gravity radiations. This decrease starts to taper off at about 25 miles below the surface, because the gravity radiations produced by the matter below this level encounter higher concentrations of soft particles, which screen out gravity radiations more effectively. Gravity decreases more slowly from this point on and doesn't reach the zero point until most of the shell is penetrated. This is due to the energies which permeate the crust, and because gravity radiations are being continuously dissipated and new radiations created. Since the concentration of soft particles in the last 150 miles is higher than in the first 150 miles below the surface, the gravity on the inner shell will be less than the gravity on the surface. Figure 3 depicts the gravity attenuation curve for the Earth shell. Gravity effects on the inner shell at any point are not offset by the gravity effects of the Earth on the opposite side, because the concentrations of soft particles in the inner Earth screen out these gravity effects.

It is apparent from the foregoing discussion that if all the matter of any gravitating body were cooled to absolute zero, its gravity effects would all but vanish. Heating a body such as the one used in the Cavendish Experiment causes a slight increase in the gravitational force. Further heating would produce only very slight increases because the average frequency of the thermal radiations increases; and therefore, the gap between the gravity frequencies and the average thermal frequency widens.

It is important at this stage to mention a book concerning the hollow Earth, the finest that has yet been written. It not only contains more important factual material about the hollow Earth than any other book, but also goes far beyond them in other respects. This great book probably contains more profound metaphysical and scientific truths than any other book written up to the present. The book is entitled *Etidorhpa* and was first published in 1895. Some books are written in the form of a novel in order to present certain ideas or truths without inviting undue attack from various quarters. *Etidorhpa* is considered by most to be a science fiction book. Any intelligent and discerning reader realizes that it isn't.

**FIG. 3. GRAVITY ATTENUATION CURVE FOR THE EARTH'S SHELL**

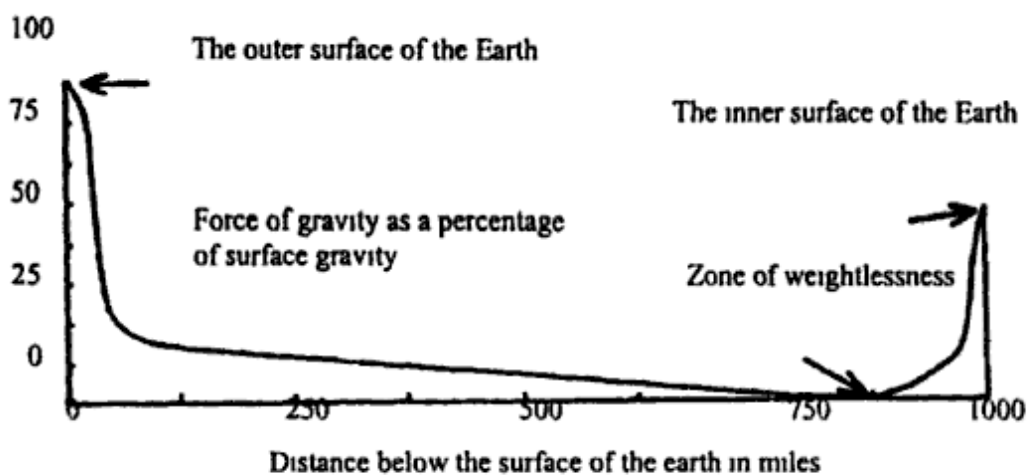

Gravity drops of rapidly in the first 25 miles due to the limited penetrating ability of gravity inducing radiations. From that point downward the rate of decrease becomes progressively less until it drops to zero about 750 miles below the outer surface. The force of gravity begins rising again in proceeding toward the inner surface. At the inner surface the force of gravity reaches a value which is somewhat less than that on the outer surface.

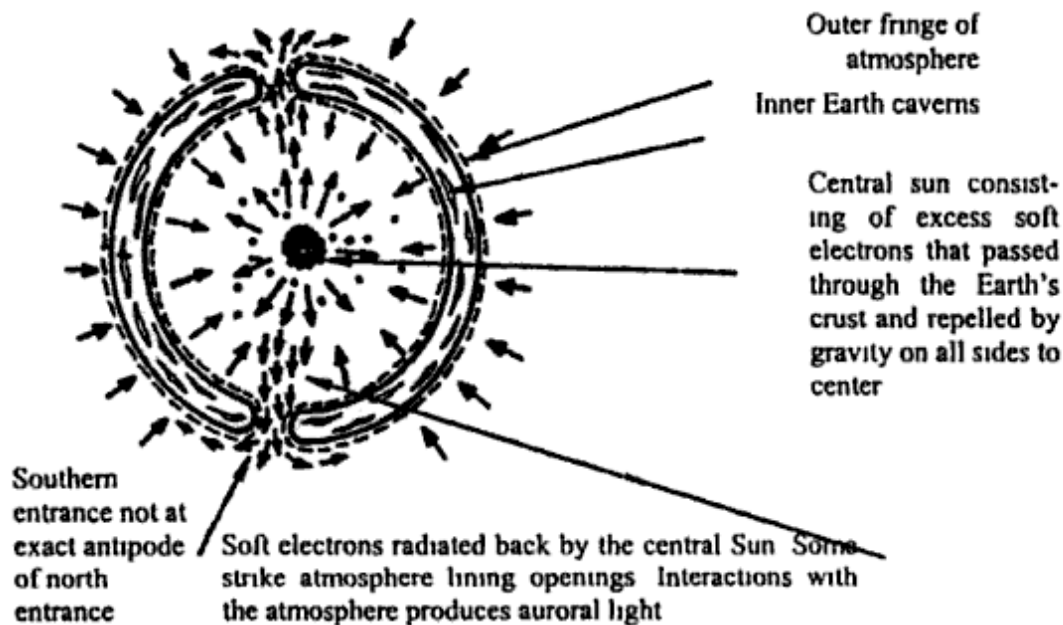

Large openings prevent excessive accumulation of soft electrons inside the Earth. They function as an exhaust system for the excess particles to escape into outer space. Where it not for this there would be a steady build-up of heat throughout the inner Earth and the crust with disastrous results.

**FIG 4 CROSS SECTION OF EARTH TAKEN THROUGH NORTH AND SOUTH OPENINGS**

The book concerns a story within a story. In Cincinnati, Ohio, during the 1860's, a young student of science had an unusual visitation from a mysterious stranger of striking appearance. This strange man, whose name was never revealed, extracted a promise from this student to publish a manuscript which the stranger was to read to him. The time of the publication was to be 30 years later. The manuscript was then read aloud over a period of time requiring many sessions. After the last reading the manuscript was presented to him along with sealed instructions to be opened at the prescribed time.

According to the subject matter of the manuscript, the stranger was taken into the hollow of the Earth through a cave in Kentucky during the early part of the Nineteenth Century. His guide was a cavern dweller who was a member of a secret organization whose objective was the preservation of vital knowledge for the future enlightenment of mankind. The objective of this trip was the inner shell of the Earth, where the nameless one was to receive advanced schooling in the mysteries of the universe. The book *Etidorhpa* described this amazing trip through the caverns of the inner Earth in detail. It also presented some of the philosophy and scientific truths the guide imparted to this man.

The author was astounded when he read the book, since it confirmed many of the new ideas he had already formulated. In fact, some of the factual material presented in the book enabled him to extend the new concepts to a more comprehensive view of the universe. It was then possible to explain many things not properly resolved in the book.

According to *Etidorhpa*, the shell of the hollow Earth is 800 miles thick, which an analysis of the satellite pictures partially confirms. Gravity at the 25-mile depth was one-third normal Earth gravity. From that level, gravity decreased gradually until it disappeared at the 700-mile depth. At that point, the narrative ended. The reasons for these conditions were not given, but they are to be expected from the principles already outlined. The protagonist was also taken on a boat ride for several thousand miles on a lake 150 miles below the surface. Evidently, this boat utilized gravity-inducing radiations for its motive power, since the occupants experienced no accelerating stresses, even though the boat accelerated from a standing start to 1200 miles/hour in a flash. They felt no rush of air, since the air surrounding the boat was carried along with them. The nature of this

propulsive force was not divulged, although the guide said that some day the outer world would utilize this principle. Another significant scientific truth revealed was that magnetic fields are the result of ether currents. This concept forms one of the principles to be introduced in Part III.

An outline of this nature cannot do justice to a book such as *Etidorhpa*. Limited space does not permit a more extensive summary. It is not surprising that *Etidorhpa* presented academic science in an unfavorable light. In this vein, a quotation from page 355 of *Etidorhpa* is congruous with the trend of this treatise: *Science has confined its labors to superficial descriptions, not the elucidation of the fundamental causes of phenomena*. This was actually a very charitable statement in view of what has been presented so far.

Seismologists believe their findings verify the conventional belief that the Earth is a solid ball consisting of an iron core 4000 miles in diameter tapped by an inner mantle of molten material and an outer mantle that is more solid. Over all of this is a relatively thin crust. They allegedly do this by tracking speeds of earthquake waves by a network of seismometers scattered around the globe which furnish a record of digital data which is fed into computers. When a quake occurs seismic waves spread through the planet from the center of the rupture. There are several points where travel times of seismic waves change considerably. Such zones are called discontinuities, and supposedly occur at the so called crust mantle boundary or "Moho" and at depths of 400 to 670 kilometers.

As is the case with other members of the scientific community, the seismologists lack the mentality to properly analyze their data and to realize that more than one interpretation can be placed on them. They display the peculiar mental process that is common in the world of academic science. It is known as reasoning in a circle. They start out with an assumption which they consider an incontrovertible fact which is treated as such in their subsequent analysis. By following this trend of thought they arrive at a final conclusion which is the same assumption with which they started!

One important factor seismologists fail to realize is that they have no reliable means of determining the exact path a given wave has followed when it reaches a certain point. The great network of great caverns and huge underground bodies of water throughout the shell of the hollow Earth would conform perfectly with the seismic data. Great masses of water could be interpreted as molten rock. Discon-

tinuities would be nothing else but boundary lines between solid portions of the shell and bodies of water along with caverns and also the inner parts of the shell. It is extremely significant that different groups in different places on the globe come up with different conclusions as to structural detail in regard to the inner Earth. On the basis of conventional beliefs concerning the structure of the Earth, this would be extremely difficult if not impossible to explain away by any rational approach. However, such results are to be expected from the information revealed thus far in this treatise. The caverns which make up the network in the Earth's shell vary considerably in their extent and distance below the Earth's surface. This would obviously create complex and variable seismic data over different parts of the globe.

Seismic data which directly refute the claims of a solid Earth have been conveniently ignored by seismologists. Earthquakes of inordinate magnitude, such as the Alaska earthquake of 1962, have caused the Earth to ring like a bell for several hours following the quake. This could not have occurred if the Earth were the solid ball that our obtuse scientists keep saying that it is. It is significant that seismic experiments on the Moon caused it to behave in a similar manner. Being of far less mass than the Earth, relatively small shocks would produce such an effect. Also the reverberation time would be less. However, the Moon did ring for nearly an hour following the experiments. This caused some scientists to speculate on the possibility of the Moon being a hollow space ship.

## **SUMMARY OF PART II**

Many of the facts and principles introduced in this part have not appeared in print before. It was shown that science has failed to explain any of the common everyday phenomena, such as tides, which are taken for granted. Further evidence was supplied showing that our planet is indeed hollow, with far better living conditions in the interior than exist on the outside. Additional steps were taken toward resolving the mystery of gravity. It was shown that popular theories in the field of cosmology are as devoid of sound thinking as many other debunked academic theories. Also, a new insight into the na-



ture of the ethers was introduced for the first time, laying the groundwork for a deeper understanding of a wide range of phenomena to be given in Part III and IV.

Greater surprises are in store for the reader in Part III. Some of the ideas introduced in Parts I and II will be developed still further and new concepts given, embracing the entire field of physics. This will also include the explanation for geomagnetism not discussed in Part II, since more groundwork in the nature of magnetism needs to be presented for a proper treatment of this subject.

## **PART III**

# **DEVELOPING A NEW PHYSICS OF THE UNIVERSE FROM THE UNIFYING PRINCIPLE**

### **INTRODUCTION TO PART III**

It has been indicated that the laws of the universe are basically simple. The operating functions, or laws of life and existence, can be defined by building upon the unifying principle to be introduced in Part III. The more attentive reader probably realizes that a powerful wedge has already been driven into the crack of the door leading to this evolution. This door will be torn asunder in the following pages. A number of surprises await the reader during this process.

This treatise has been written to appeal to the widest range of individuals. There is a considerable amount of highly technical material in this section on the new physics, and some readers may find it difficult. Part III also has something to offer those who do not comprehend much of the technical material.

Concepts presented in the first two parts will be expanded upon, and others will be introduced for the first time. The reader will be given a bird's-eye view of the fundamental particles of matter, and how they function within the atom. The nature and relationship between electrostatic and magnetic fields will be clearly shown. The properties of light and methods of propagation are part of this program. A complete analysis of the nature of gravity is given, followed by new interpretations of some of the revolutionary discoveries of Wilhelm Reich.

The last subject in Part III concerns "free energy" devices. Free energy is a misnomer since the conservation of energy must hold true. It is the heretofore misunderstood and unknown nature of the

universe which leads researchers to speculate on what is called "free energy".

All of the devices described herein obey the conservation law, even though the term "free energy" is associated with them. Also included is the description of a simple and practical self-sustaining electrical generator. It will be shown that the so-called "energy crisis" is a gigantic fraud thrust upon the world by mental degenerates in high places, and that many practical free energy devices have been suppressed for many decades by such miscreants.

One of the most significant aspect of the section on free energy is an analysis of the nature and growth of crystals, and a demonstration that they are the greatest potential source of energy. More of the shallow and faulty reasoning fostered by academic science is brought to a sharp focus as this section unfolds.

## CHAPTER 7

### FUNDAMENTAL WEAKNESSES IN CONVENTIONAL MATHEMATICS, INCLUDING A DISPROOF OF TWO OF THE MOST FAMOUS PREVIOUSLY UNSOLVED THEOREMS OF MATHEMATICS

Modern theorists have nearly always assumed that the phenomena of the universe cannot be explained in terms of mechanical models. Consequently, they rely on mathematical descriptions, as a proper treatment of the subject. This trend has been carried to such ridiculous extremes, they have come to believe such procedures constitute satisfactory explanations! Quantum mechanics is a classic example. An article on the subject, by the well-known physicist, Freeman J. Dyson, entitled, "Innovations in Physics", appeared in the September, 1958, issue of *Scientific American*. This article was revealing in a manner the author obviously never intended. It was stated on pages 77 and 78, that during the difficult learning period, the student finally discovers that there is really nothing to understand about quantum mechanics. He learns the subject when he becomes able to manipulate the mathematics so as to get the right answers! The training period to which Dyson alluded, was a perfect description of a brainwashing process. Also, it is similar to that described in Orwell's novel, *1984*, which enables one to become an artful "doublethinker".

This excessive dependence upon mathematics as a tool, probably, had its origin in the works of James Clerk Maxwell, generally considered the greatest theoretical physicist of the Nineteenth Century and rightly so. Maxwell had an extraordinary ability to use mechanical models to explain physical phenomena. In fact, he made his greatest discoveries in this manner. He coupled this with an unequaled ability to translate physical imagery into mathematics. Unfortunately, he then published his findings in terms of mathematics with the models left out. His predictions later proved to be so accurate in certain respects, that subsequent theorists assumed that mathematics was the only approach to understanding the mysteries of the universe. These

physicists were not Maxwell, and as such, lacked the imagination to use such models as well as Maxwell did. The many bizarre and nebulous ideas being expounded upon by today's "theorists" demonstrate that too much dependence upon mathematics can lead one into a dream world, with little bearing upon reality. There is always the hope that some unique solution to certain equations will bring about a new revelation concerning the mysteries of the universe, and thereby duplicate Maxwell's achievements. A simple fact many physicists do not seem to understand is that the validity and significance of a conclusion, derived from mathematics, is dependent upon the quality of the assumptions and thoughts upon which it is based, regardless of the mathematics employed.

There is no reason to believe mathematics has attracted any better minds than has conventional physics. It is reasonable to conclude that the quality of thinking among mathematicians, is generally no better than that demonstrated by physicists. It then follows, that mathematics should be steeped in blunders as egregious as those in physics. Just a little digging below the surface shows this conclusion to be thoroughly justified.

By following this process, the outstanding blunders crop up rivaling the Theory of Relativity and the Theory of Tides in vacuity. The first mathematical blooper to be considered concerns the work on so-called transfinite numbers by the Nineteenth Century mathematician George Cantor. His theory is considered a milestone in the history of mathematics and is still a part of college curriculums in higher mathematics. He allegedly proved by the most specious type of reasoning, that the real numbers are not countable. This laid the groundwork for his theory of transfinite numbers. Briefly, his "proof" called the "diagonal proof" consisted in the hypothetical arrangements of all the numbers in horizontal rows in successive orders of magnitude. He claimed that a diagonal path can be drawn through the list which contains a number that is not on the list. It seems very plausible on the surface but it happens to be a crass violation of the laws of permutations and combinations taught in high school math. The ten digits used in our number system can only be arranged in a finite number of ways if the number of digits in any number is less than infinity. The formula for this maximum number is  $10^n - 1$  where  $n$  is the number of places or digits in the number. This assumes that zero by itself is not a number. When  $n$  is 2 there are  $10^2 - 1$  or 99, of  $n = 3$  it is  $10^3 - 1$  or 999 and so on. Cantor's assertion violates this law.



Another flaw in his reasoning is that the real numbers can't be arranged in such a neat pattern since the number of places will vary. This means the path will pass through regions with no numbers. It follows this path cannot pass through a number that is not on his list. Since Cantor received a lot of "flack" from leading mathematicians of the day for his speculation it seems reasonable to assume at least some of them must have seen these obvious flaws. One of the numerous absurdities spawned by Cantor's speculations was his claim that all lines regardless of length have the same number of points. This means a line one centimeter long has as many points as one a thousand light years in length. It follows that for every point on the short line there will be an infinitude of points a centimeter apart on the other. Of course each has an infinite number of points but any statement that each has the same number of points is merely a play on words, far removed from reality.

This is a demonstration of how theorists and speculators of his caliber misuse the concept of infinity. Some functions approach infinity at a far greater rate than others as is the case above. For any value less than infinity there will always be disparities among all things that approach infinity. Since reality is always involved with things that are finite the complete nonsense contained in Cantor's theories becomes more than evident. In view of this it is incredible that Cantor's work is still a part of school curriculum in higher math.

## **FOUR-COLOR THEOREM**

The second mathematical blooper, centers around the famous Four-Color Theorem, which has been stumping mathematicians for the past 150 years. This theorem states that four colors are sufficient to color any map on a plane surface, so that no two adjacent regions are the same color. The consensus among mathematicians, is that this conjecture is valid, since no one had ever been able to disprove it by devising a map that requires more than four colors.

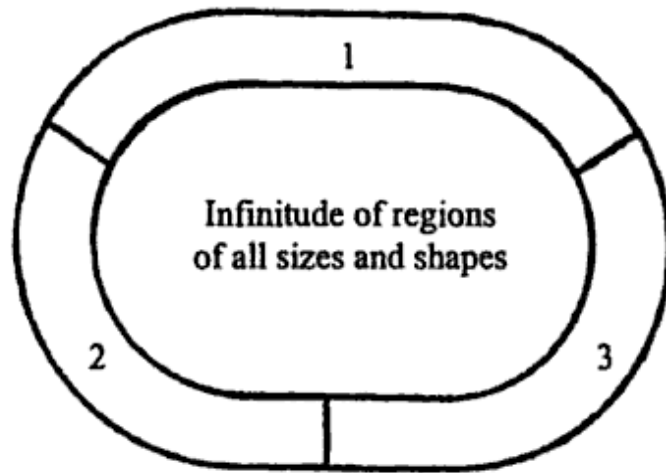

**FIG. 5. ILLUSTRATION SHOWING THE INVALIDITY OF THE FOUR-COLOR THEOREM**

Finally in the year 1977 two mathematicians at the University of Illinois announced to the world a proof of the validity of the four-color theorem. They allegedly achieved this monumental feat with the use of one of the nation's most sophisticated computers with a total of 1,600 hours of computer use and years of hard work. The October, 1977, issue of *Scientific American* featured an article about this milestone in the history of mathematics. Said article included a map of several hundred regions that had been four-colored. There was only one thing wrong with this map. Each of the four colors appeared a minimum of 12 times on the periphery of the map! This automatically renders it at least a 5-color map by surrounding this map with another region.

One might argue such a map can be converted into a four-color map by first using only three colors to color all the regions bordering the periphery. Indeed the outside can be three colored but this presents an insurmountable difficulty. If the coloring of certain regions are predetermined, a properly drawn map of even a few regions cannot be four-colored. The predetermining of colors greatly restricts subsequent

coloring and therefore more than four colors become mandatory in such a map as above.

In view of this it becomes obvious, that a 7-color map can be drawn, if the surrounding region mentioned above is divided into three equal parts each bordering on the other two. This will even render the map appearing in *Scientific American* a seven-color map since the colors are quite evenly distributed along the outside. To render the argument even more convincing consider a map of billions of regions once more surrounded with the three mutually bordering regions as shown in the diagram in Figure 5. It is immaterial where one starts the coloring process but for convenience assume the coloring starts near the center and proceeds outward. It is obviously an impossibility to color it without each of the four colors appearing countless times along the entire periphery. Each has the same likelihood of appearing on the outside. It follows the greater the number of regions the closer each will emerge on the outside an equal number of times percentage-wise.

An obtuse person might argue that the three outer regions of the above map can each border on three different colors the combination of the three color is different for each segment. For example, A could border on colors 1, 2 & 3. B on 2, 3 & 4 and C on 1, 2 & 4. In this manner only four colors are used. Once again this creates insurmountable difficulties in subsequent coloring. The inner coloring process will now be restricted in three different ways. Long before the coloring process is finished at least seven colors will be required and perhaps more. The coloring process starting in the center simply demonstrates the impossibility of coloring such a map with less than seven colors.

This puts the lie to the claim a Nineteenth Century English mathematician proved that a map in a plain can always be colored with just 5 colors. This alleged proof appears in a number of college text books. The author could no doubt put his finger on the flaw of this alleged proof but it is much easier and more convincing to present a counter example.

Does seven represent the maximum number of colors needed to color any map, or is there an upper limit? It is apparent that mathematicians and four-color enthusiasts have only considered maps, wherein the regions are all of nearly the same shape and order of magnitude in area. Under such restrictions, the four color theorem may well be valid when the border is not taken into consideration. However, when there is a tremendous range in relative sizes and

shapes, the four-color theorem quickly breaks down as has just been shown. Instead of just two categories, the very large and very small, as just discussed, consider an unlimited number of similar categories with each category, bordering on all categories below it in magnitude. There are great numbers of each category, bordering on each region, comprising all categories of greater magnitude. It is clear that as the number of categories increase, the number of colors required will also increase, if the above pattern is followed. It can be concluded that there is no limit to the number of different colors required, when maps of this type are considered. It does seem incredible that such a seemingly obvious counter example has been overlooked for so long by leading thinkers. It is simply another of the many examples already presented showing how the obvious keeps escaping the scientific world.

The two mathematical blunders just described, no doubt represent only the tip of the iceberg, so to speak. Careful probing would more than likely uncover many more, just as obvious. This, the author will not attempt. There are far more important and fruitful endeavors requiring attention.

Perhaps the most overlooked flaw in mathematics, which greatly restricts its areas of application, is the loose and indiscriminate use of the term, "equal", upon which equations are derived. Certain terms are substituted for others on the basis that they have one thing in common, during the derivation of an equation. This is done without considering the possibility that other aspects of these terms may have nothing in common with each other, and as such, might have a distinct bearing on the problem to which they are applied. Many equations are valid and useful when such a problem does not exist. This has been the case with the mathematics used in this treatise. For example, consider equations involving areas, volumes, and masses. The aspect of shape has not been considered, and has no significance in the final solution of the problems to which they have been generally applied.

The limitation of mathematics is fully demonstrated in a paradox involving the well-known kinetic energy equation:  $E = \frac{1}{2} mv^2$ . The paradox is discussed and resolved in Chapter 13 under the section "Why the Velocity of Light Equals the Ratio Between EMU and ESU Units of Charge".

Mathematicians of the past and present, have devoted an unbelievable amount of time to idle speculations and worthless pursuits. There are certain self-evident facts which cannot be proven,

at least within the framework of the present system of mathematical logic, and do not require proofs. As an example, consider the following hypothesis: First, *One and only one line can be drawn through a point, parallel to another line.* Second: *Two parallel lines will never meet, no matter how far they are extended.* Amazingly, many mathematicians have devoted a good portion of their lives, trying to prove or disprove these axioms. Many mathematical physicists have come from their ranks. Pure mathematicians have supplied the tools for modern theorists' excursions into impossible dream worlds. For example, the Nineteenth Century mathematician Reimann, invented the type of geometry Einstein employed to develop the General Theory of Relativity.

In this century, the trend has been to solve physical problems, using solely abstract mathematics. This approach violates an Hermetic Axiom, to be introduced shortly, the Law of Cause and Effect. Intangibles do not produce tangibles. Since we live in a mechanical universe, it follows that the underlying causes may best be shown in terms of mechanics. It seems logical to assume that this is the only way it can be done.

Before continuing to the next chapter, it should be mentioned that scientists have gone from one absurd extreme in regard to dependence on mathematics, to an opposite extreme. In the first case, mathematics has been overemphasized. Yet, in other instances, they have failed to take into consideration, even the most elementary mathematical principles. A prime example involves the relationship between surface area and volume. Volume increases as the cube of a linear dimension, while surface area increases only as its square. Entomologists have been mystified by the apparent strength displayed by insects in proportion to their size. In reality, this is only a demonstration of the mathematical principle. It does seem unbelievable, but much research is still being made in an effort to discover the secret of their physical prowess. The insect is actually very inept for its size. If an animal or a human were reduced to the size of an insect, and still retained its cellular structures, either one would far out-perform the insect. Evidently, mental ineptitude in the realm of science is not restricted to the physical sciences. The simple fact that animal tissues are much stronger than those of insects, was overlooked.

Assuming that physical or organic structure remains constant, the lifting ability, in proportion to weight, will vary inversely as the cub root of the weight. This is apparent in the lifting records among

weight lifters. The smaller men, in general are always lifting more in proportion to their weight than the bigger men. In fact, weight lifting records in the various weight lifting divisions, from Bantamweights to the Super Heavy Weights, closely follow this formula. An application of this formula shows that if a top lifter were reduced to the size of an ant, he would be able to backlift thousands of times his own weight. Has an ant, or any other type of insect, ever remotely approached such a performance?

“It will be shown later, that this same mathematical principle is the governing factor in the source of the sun’s radiant Energy.”

The best part of this chapter demonstrating the fallibility of famous mathematicians past and present has been reserved for the last part. It involves the most famous of all the previously unsolved theorems of mathematics.

### FERMAT’S LAST THEOREM

It has been a source of frustration to all of the world’s best mathematicians for 350 years, to say nothing for millions of others. It is the product and legacy of a 17th Century mathematician, Pierre de Fermat. He had a habit of scribbling mathematical information in the books he read. In one particular book, he wrote down an elementary theorem on whole numbers, to which he added the note, “I have discovered a truly marvelous demonstration which this margin is too narrow to contain.” The theorem is a generalization of Pythagoras’ work on right angle triangles, which states the square of the hypotenuse equals the sum of the squares of the other side. Stated algebraically, it is  $x^2 + y^2 = z^2$  where  $x$ ,  $y$ , and  $z$  are the sides of the triangle. There are triplets of whole numbers that satisfy this condition when the exponent is 2 such as 3, 4, and 5, since  $5^2 = 4^2 + 3^2$ . There are allegedly no whole numbers that satisfy the relation when the exponent is greater than 2, or in other words, for the relation  $x^n + y^n = z^n$  no whole numbers can be found that satisfied it when  $n$  is greater than 2.

Seldom has the author been highly motivated to tackle any puzzle or brain teaser that do not have useful or practical applications. Consequently, he cares little for games such as bridge or chess. In order to become effective the author must have great incentive. Therefore, he would not make a great chess or bridge player. Prior to



the solution of the two most famous unsolved problems in mathematics, the last time the author was sufficiently motivated to tackle a real brain-teaser with effect was over 40 years ago.

It involved another Fermat theorem which he had presented without proof. It is: The value  $(n^p-n)$  is divisible by  $p$  if  $p$  is a prime number where  $n$  is any whole number. This one is so difficult it remained unproven until Leibnitz, the co-inventor of the calculus with Newton, proved it many years after Fermat's demise. It was mentioned in E. T. Bell's *Men of Mathematics* as a super intelligence test. This writer also found a proof of it. Once the author was satisfied, the details of the proof were soon forgotten. Consequently, in order to replicate it this writer would have to start from scratch again. This he will not do.

An article in the Jan. '89 issue of *Discover Magazine* titled "Fermat Still Has the Last Laugh" motivated the author to tackle this most famous of all mathematical theorems. He decided a solution should go in this book. After some stumbling two solutions were found. Each solution clearly showed the theorem is false as is the case with the four color theorem!

Recently, Andrew Wiles, a British mathematician, announced to the world he had found a proof of Fermat's last theorem. It created a stir throughout the mathematical world. Major newspapers ran articles featuring this "monumental" event. The alleged proof was so profound and complex it was stated only about 1/1,000 of the world's mathematicians would be able to understand it.

Finally, the Oct. '93 issue of *Scientific American* went into more detail concerning this milestone with an article titled "The End of Proof". Therein it was revealed the proof covered over 200 pages and had it not been for the abbreviations used it could have covered 1,000 pages! The following is a letter the author sent *Scientific American*. As the reader can see it is self-explanatory and no more will be said about the theorem. Some of the things mentioned in this letter will be shown in more detail later on in this book.

Joseph H. Cater  
10-8-93  
1646 SE. Elliott Ave.  
Portland, Ore. 97214

Editors of Sci. American

Dear Sirs:

The article "The End of Proof" by John Horgan, in your latest issue, is a perfect example of your policy of foisting weird, irrational and inexplicable speculations of fuzzy thinkers like Wiles on the public. Nature's laws are basically simple. This means there is a simple explanation (and proof) of any phenomenon and things of a mathematical nature as I have shown time and again. It takes far more intelligence to find a simple solution than a complex one because there are fewer of them. The more complex the alleged solution the more likely it is to be false. Also the trend shows a progressive lack of insight and greater confusion. This is carried to dogmatic extremes when we get to Wiles' alleged proof. This is the work of a great fool not a great thinker.

Being a media publication, *Sci. American* will exhibit tunnel vision and will ignore any truth that is contrary to established "concepts" (that is if the absurd speculations of pseudo-theorists can be dignified to the extent of being considered concepts). It has been my experience that academic "scientists" in general will believe only what they want to believe and reject anything that confutes cherished beliefs. The corruption that permeates the scientific community is mind-boggling. The policy of your publication and all other media publications is to uphold that status quo at all costs. Truth has to take a back seat.

Mathematics per se is as steeped in bad logic and false proofs as is academic physics. I will give a few glaring examples before I get to Fermat's theorem. About 14 years ago an alleged proof of the validity of the four-color theorem created quite a stir. Two Ohio State mathematicians supposedly found one after 1,600 hours of use of one of the country's most sophisticated computers. Your publication celebrated this "monumental" event with a feature article. To demonstrate its validity a map of several hundred regions was four-colored. Instead of demonstrating its validity the reader had a potential 7-color map staring him in the face. Each of the 4 colors appeared at least 12 times on the periphery! All one had to do was surround this map with 3 regions, each bordering on the other two. There is no way one could color such a map with less than 7 colors. One might argue that one could first 4-color the outer regions. This procedure would result in the use of more than 7 colors because of the restrictions placed on subsequent coloring. What kind of problems would one have with an infinitude of regions of all sizes and shapes? Why did it

have to be me to recognize this discrepancy? I could write a large book on minor lapses of this magnitude committed by the scientific community.

One of the most horrendous misconceptions in the history of math was propagated by Cantor with his transfinite number theory. Incredibly it is still hailed as a monumental achievement. His alleged diagonal proof which established this monstrosity violated elementary principles of permutations and combinations! It is to be expected that conclusions derived from it consisted of nonsense of the worst kind. For example, a line of infinitesimal length is supposed to have as many points as one of any given length. Let's examine this inanity more. Take a line one cm long and one  $10^{20}$  cm long. For each point on the one cm line, there are  $10^{20}$  points on the other. As one proceeds toward infinity the same disparity exists. Obviously this line will always have  $10^{20}$  times more points than the other. What this great fool didn't realize is that he was treating infinity as a real number. The only realities that exist with infinity are:

$$\frac{\textit{Finite number}}{\infty} = 0 \qquad \frac{\infty}{\textit{Finite number}} = \infty$$

The above are only two of the many incredible fiascos that exist in mathematics. The most amazing of all centers around Fermat's last theorem. Here is a false theorem in which the proof of its fallacy is almost self-evident. Yet, it has escaped all of the world's leading mathematicians for about 350 years!

The key to understanding the problem lies in a very simple fact. Consider any two numbers  $a$  &  $b$ ;  $(a-b) < (a^2-b^2) \ll (a^3-b^3) \lll (a^4-b^4)$ , etc. when  $n = 1$  in the equation  $x^n + y^n = z^n$  the distribution of integer triplets that satisfies the equation is an absurdity. When  $n = 2$  this distribution thins out tremendously simply because  $(a^2 - b^2) > (a - b)$ . When  $n = 3$  this distribution thins out further to a mind-boggling degree. It obviously doesn't vanish because there are an infinite number of triplets out there that can produce an infinite number of combinations which includes any combination; most certainly those that satisfy the equation  $x^3 + y^3 = z^3$ . A most incredible oversight occurred in 1981 when integers were found that satisfied the equation  $x^4 = y^4 + z^4 + u^4$  or  $422,481^4 = 95,800^4 + 217,519^4 + 414,560^4$ . Mathe-

mathematicians weren't sharp enough to realize this was more difficult than finding a 4th power that equaled the sum of only two 4th powers, the fixation that Fermat's theorem is valid and therefore such a thing is impossible was no doubt the reason it escaped them. How much easier it would have been to find integers that satisfied the equation  $x^3 + y^3 = z^3$ !

For the more obtuse who must have equations to guide them in their thought processes the following proof will be given. Let  $x^n + y^n = (y + a)^n$  expanding with the binomial theorem it becomes:

$$x^n + y^n = y^n + n a y^{n-1} + \frac{n(n-1)a^2 y^{n-2}}{x^2} + \dots a^n$$

To shorten this demonstration numerous steps will be left out. Let  $y = x - b$ . Let  $x = C(a+b) = Db$ . The idea is to find a relation for  $x$  in terms of  $a$  &  $b$ . This will provide for the first time an algebraic overview of the entire problem. When this is done, the validity of the theorem boils down to assuming  $a$ ,  $b$  and  $x$  are integers. If they are then a contradiction will arise if the theorem is valid. If not there will be no contradiction. This is precisely what happens. It is found:

$$x = CD \sqrt[n]{\frac{[(a+b)^n - b^n] C}{b(D^n - C^n)}}$$

This is a general equation that holds for all values of  $x$ . Let  $x = b(a + b)$ . The value under the radical becomes unity &  $x = CD$  which means  $x$ ,  $a$  &  $b$  can be integers. It should be kept in mind values of  $x$  in this form will make up only a very minute portion of counter examples to the theorem.

What does this do to the reputation of mathematicians past and present who have allegedly proven the theorem holds for values of  $n$  from 3 up to 125,000? By the domino effect it will also immediately call to question many other alleged proofs in mathematics. As is the policy with the scientific community truth does not have a high priority. This fact will never be publicized as was the fact the 4-color theorem was confuted has been conveniently ignored. More than likely Wiles will be given credit for "proving" it valid and will be awarded the prize by the examiners at Göttingen to close the book on it. They were presented with the above proof but had one of their subordinates informed me it wasn't proven false. They, of course,

failed to give any reason or present any loophole which obviously they couldn't. It is standard procedure and good manners (if trouble is taken to write a contributor) to give a reason for a rejection not the infantile response I received. From the content of the letter it is obvious they tried to give the impression they hadn't read my manuscript and merely turned it over to a subordinate who deals with "non-professional mathematicians". It took almost two months to get this response. They were no doubt shaken up by my proof and did their best to protect the reputation of fellow mathematicians. Incidentally this writer has very good reasons to believe a computer search found a counter example some time back. In the interest of mathematics and mathematicians it had to remain a deep, dark secret.

There are basically two kinds of math: (1) math that deals with realities and (2) math that deals with fantasies that have no bearing on realities. The latter is the type employed by present-day pseudo-theorists such as Stephen Hawking and others who are championing such monstrosities as string theory. They continue to prate about the finding of a great unification that explains all. Such a breakthrough has been with us for a long time and has done everything that could possibly be expected of a valid concept. It is known as soft particle physics. Guess who developed it. No high powered math was used, just common sense. Math deals only with the quantitative aspects of the universe, not the qualitative. Therefore, math is the wrong approach toward finding a unifying principle. This should have been obvious to even the greatest fools among us. What is the difference between a great fool and an ordinary fool? The great fool has the ability to carry absurdities to greater lengths than can the ordinary fool. The greatest fool in physics of the present day is Hawking. He ranks with Einstein as the greatest fool in the history of physics. Einstein had the advantage because he was a paraplegic only from the neck up while Hawking is a paraplegic from the neck both ways. Wiles and Cantor are more than likely the greatest fools in the history of math.

Some years back this writer issued Hawking and his associates a challenge. They haven't seen fit to take it up because they know I could bury them.

Back in the 1930s the legitimate scientist Oscar Brunler developed a science and a fool-proof method of measuring the true mental potential. It rendered obsolete all current methods of determining intelligence which measure only a small and relatively unimportant

aspect of intelligence. It showed that many who were considered geniuses by the conventional method were far from the genius level. This science has been largely suppressed for obvious reasons. However, the U.S. government has been using it behind the scenes for some decades to get a line on everyone they are concerned with. This includes millions and, of course, yours truly. The potential is known as the Brunler number. It would be most interesting to get their list. Einstein, as to be expected, was far from the genius level. They found mine to be a bit scary. This explains why it is me who keeps finding all these discrepancies and who independently developed this new science.

Joseph H. Cater

The reader may wonder why such a simple solution to Fermat's theorem has been overlooked for well over 300 years. It is no more remarkable than many other seemingly obvious facts already uncovered in this treatise that have been overlooked for such a long time. The above constitutes perhaps the author's last venture into abstractions that have no practical value as far as comprehending natural laws and the nature of reality is concerned. Since this solution was presented to many in the math world would the reader care to make any large scaled bets that it didn't spark a computer search for a counter example which was found? Since it has been allegedly proved the theorem holds for all values of  $n$  up to 125,000, this would tarnish the reputation of many mathematicians past and present and also call to question other celebrated proofs in mathematics. In view of the lack of integrity displayed by the scientific community one should expect such eventuality to be covered up. Since nature's laws are basically simple, as is demonstrated throughout this treatise, a complex of mathematical equations does nothing to enhance one's understanding of the universe. Instead, they only obscure it. One can be certain that any treatise concerning natural phenomena accompanied by a network of complicated mathematics indicates the author is only trying to impress the reader with his profundity. The author has yet to run across any paper in which the mathematics contained within had any significant bearing on the subject matter. Mathematical abstractions churned out by mathematicians past and present supply pseudo-theorists with the tools they need for impossible excursions into dream



worlds that have no bearing on reality. The latest of these monstrosities is known as superstring theory. It seems the universe arises from oscillating strings about  $10^{-33}$  cm long that move around in tight loops. This movement produces particles. The more intense the movement, the heavier the particles. They are supposed to vibrate in more than three dimensions. They are allegedly of spatial dimensions and one time dimension. To make this picture even more grotesque, each string possesses another 16 dimensions within it!

Some of the mathematics used by these profound "theorists" who are stringing us along were supplied by the Hindu mathematician Ramanujan. He had an uncanny ability to churn out large numbers of theorems, mostly involving number theory. The facts indicate most of them were derived intuitively rather than by hard analysis. He had a unique ability to tune into cosmic computers (to be discussed later) and came up with theorems previously unknown by the world of mathematics. He was what could be termed one-dimensional since he seemed to be oblivious to anything outside of the abstractions that were his obsession. Other savants of this type can do calculations that outstrip the most sophisticated computers. One of them found the 17th root of a 206 digit number in only 50 seconds!

## CHAPTER 8

# NEW INSIGHTS INTO THE NATURE OF MATTER, INERTIA AND THE ETHERS WITH AN INTRODUCTION TO THE MEANING OF PLANCK'S CONSTANT

One of the most fundamental physical laws involves the relationship between the electrostatic and magnetic fields. It was indicated earlier that a magnetic field develops at the expense of an electrostatic field. One transforms into the other and vice versa. They are analogous to different sides of the same coin or another manifestation of the law of duality. Dualities cannot exist by themselves. It requires a third ingredient to give them reality. In order for a coin to have two sides, it must have thickness to give it substance or reality. Things manifest in terms of surfaces in two dimensions. It always requires a third dimension to make them a reality. This third factor is the fulcrum through which and by which dualities must manifest themselves. This is known as the law of the trinity or the triangle. Space, therefore, must only have three dimensions. The idea of fourth or higher dimensions is the product of badly confused minds, unable to comprehend the seemingly perplexing experiences they sometimes encounter.

Inertia, then, becomes the third factor involved in the relationship between the electrostatic and magnetic fields. Energy cannot manifest itself without forces being involved. Without inertia, forces do not exist. Inertia, therefore, is an intimate and inseparable part of all energy phenomena. The cause of inertia or the reason that mass has inertia has remained a mystery to the world's leading thinkers for the 300 years, or since Newton first defined it. A clue to understanding it can be found in Faraday's law stating that an induced electromotive force, is produced by a change in the flux. If we substitute "force" for electromotive force in the statement of this law and "velocity" for magnetic flux, which will be shown to concern

velocity, then the law can be restated: "the induced force produced by a change in velocity is always in such a direction as to oppose any change in this velocity". This is another definition of inertia.

The factors governing inertia can be derived from the following consideration: the kinetic energy of a moving charge is manifested in its magnetic field. This magnetic field develops at the expense of its electrostatic field in order for the law of conservation of energy to remain intact! The role of inertia and the conditions governing its magnitude are now apparent. The inertia of a body is dependent on its ability to generate a magnetic field when it is given a velocity. The greater its inertia, the greater is this ability.

The magnitude of the inertia of a body is directly proportional to the energy of the magnetic field the body develops for a given increase in velocity. It then follows that inertia is dependent on the total electrostatic charge of a body. This is also true for so-called "uncharged" matter. It will soon be shown that in the supposedly uncharged state, all atoms and molecules have a net positive charge. Therefore, even atoms and molecules develop a magnetic field when they are given a velocity. In order to demonstrate this, the ethers must be considered, as well as the nature of light, photons, and the basic structure of positive and negative charges.

## **THE NATURE OF THE ETHERS AND THE MEANING OF PLANCK'S CONSTANT**

A principle that makes possible the understanding and unification of a wide range of phenomena has been known for thousands of years. It is one of the Hermetic Axioms that is a part of esoteric teachings. It is usually stated "as above, so below". This boils down to the idea that the same basic principles underlie all phenomena and that all things interrelate in some way. From this come the laws of cause and effect. It follows that much of the nature of causes can be deduced from its effects, or that many of the properties of the unseen can be determined from that which is seen.

This great axiom is the second of seven principles upon which the entire Hermetic philosophy is based. It has come down to us after thousands of years from its founder, Hermes Trismegistus, who lived in ancient Egypt. All of the basic teachings embedded in the

esoteric teachings of every race can be traced back to Hermes. He was regarded by all advanced occultists and those of high learning as the Master of Masters.

His influence was so profound that, despite all the deviations from that which he taught, it has survived the centuries and today there is still a basic resemblance to his teachings which, along with conflicting theories, are still taught by metaphysical teachers of these various countries today. Students of comparative religions can recognize the influence of Hermetic philosophy in every major religion. The original truths expounded by Hermes have been kept intact in their original form by a few wise men in each generation. Consequently, they have been handed down from initiate to initiate and have been preserved for the few who are capable of comprehending them. This Second Axiom, known as the Principle of Correspondence, will be applied in this treatise toward the unfolding of mysteries never before resolved. However, this treatise embodies all seven of the Hermetic Principles and demonstrates the truth contained within them. In fact, the ancient Hermetic philosophy comprises the skeletal structure of this book.

Since the axiom suggests that the nature of the ethers can be deduced by certain aspects of our surroundings, the most logical one to consider is the property of a perfect gas. Although there must be significant differences between a gas and the ethers, there must be certain properties that they have in common. An object can travel through free space at a steady velocity and encounter no measurable resistance. Yet, it apparently does encounter resistance during an acceleration. A similar pattern occurs during passage through a gas or atmosphere but to a more pronounced degree. When inertia isn't a major factor, a hollow object, for example, will experience great resistance from the gas if there is a great and sudden change in velocity. After it attains a given velocity and this velocity remains constant, the resistance is greatly reduced. Therefore, it is logical to assume that the inertia exhibited by a material object is due to the presence of a subtle medium that possesses some of the properties of a perfect gas. If there were no medium present, it would be somewhat difficult, if not impossible, to account for inertial properties.

The analogy of, and similarity between, the behavior of a near massless hollow ball in a gas and that of a body of great mass in free space is an application of this all-important Hermetic Axiom. As will become increasingly evident, further application of this line of

thought leads to extremely fruitful results. It has been established that at the same temperature and pressure, all gases have the same number of molecules per unit volume. This means the average distance between molecules from center to center is the same for all gases, regardless of their molecular weight. Since they exert the same pressure, it follows that the average kinetic energy of the molecules is the same for each gas. This means the average velocity of a gas molecule varies inversely as the square root of its molecular weight.

Applying these conclusions to the ethers, it follows that the average distance between ether particles is a constant, as well as is their average kinetic energies, regardless of the ethers considered. Since particles of matter have inertia, ether particles must have inertia as well. The reasons a body traveling through a gas at constant velocity encounter resistance, yet the ethers offer none, will become apparent later. Ether particles, and atoms, or molecules must also have certain properties that are similar. It will be shown later that atoms and molecules have zones of attraction as well as repulsion. It is vital that ether particles also possess such zones with regard to each other. The zonal effects around atoms are the result of the interactions of the fundamental particles, the electrons and protons. Therefore, ether particles also consist of fundamental particles similar in structure to electrons and protons. This is a manifestation of the Law of Duality. Basically, there are only two kinds of fundamental particles, contrary to the viewpoint of particle physicists.

It follows that the particles of the highest ethers correspond to our hydrogen atom and the basic particles that comprise it are the basic ingredients of all the ethers in all the realms that concern us. The lower ether particles correspond to the largest and most complex molecules.

It will soon be shown here that ether particles combine to form particles known as photons of light. This combining, or sticking together, corresponds to the cohesive forces of atoms and molecules which makes possible the formation of matter. It is the zonal forces around atoms and molecules that are responsible for these cohesive forces. Likewise, zonal forces around ether particles enable photons to evolve. These same forces enable photons to combine to form the fundamental particles of each realm, as will be described in more detail later.



The behavior and function of ether particles is duplicated with other particles in the realms of matter. The more active the particles, the more stable they need to be. The particles of the ethers are far more active than the fundamental particles of matter, and it follows that they are correspondingly more stable. The greater stability is also apparent from the following considerations. When ether particles combine to form photons the areas of contact are minute compared with the surface area outline of the ether particles. When photons combine to form fundamental particles of matter, the combining or sticking forces are the cohesive forces of the ether particles as it was when ether particles combined to form the photons. It is apparent the areas of contact between photons are not greater than between ether particles themselves. Yet, the same net forces are required to hold together far greater masses. It is analogous to using a certain glue to bind together a group of marbles and then using the same amount of the glue to hold a group of huge boulders together.

As will be shown later, cohesive forces or zonal effects are due to electrostatic forces. Electrostatic forces are produced by the bombardment of ether particles against the fundamental particles. In turn, the fundamental units of ether particles generate their version of electrostatic forces as a result of bombardments due to a very special ether from which the fundamental units of ether particles are comprised. Once again the second Hermetic Principle is involved and also The Principle of Mentalism which states "The All is Mind; The Universe is Mental". It is the basic ingredient of all creations in the universe. As such, it is the common denominator of all manifestations and phenomena and is the channel by which all thought is transmitted. The manner by which the creative intelligence controls the particles of this ether is, of course, beyond the scope of this treatise. It is of little concern to us, as far as comprehending subsequent phenomena is concerned, and the material to be presented. It is convenient to think of all the basic ether particles as being interconnected by life lines or lines of communication through which the all pervading intelligence controls them.

Cohesive forces play only a small role during the combination of atoms to form molecules. As will be shown later, there is a partial and mutual interpenetration of atoms. The nuclei of the atoms tend to remain intact but the combination bears no resemblance to any of the atoms involved. This generally results in a stable combination. The same pattern applied, of course, with ether particles. Conse-



quently, they are extremely stable. The larger and more sluggish ether particles of the lower ethers correspond to cells of the physical realm. The numbers of different kinds of ether particles is at least as great as the number of different kinds of atoms, molecules and cells. The number is astronomical. The concept, the ethers are the essence of everything that manifests is unique and goes far beyond any previous ideas concerning the nature of the ethers. This will become increasingly evident as this treatise unfolds.

Since the electrostatic field around a particle changes with its velocity, velocity becomes very critical to the motion of the fundamental particles of an atom or molecule. For example, if the velocity of an electron in a stable orbit should increase due to the presence of another particle or particles in the vicinity, it would tend to escape from the atom. The electrostatic force holding it in orbit would decrease and it would move away from the nucleus. At the same time, this force which decreases in accordance with the inverse square law will contribute further to the loss of the electron. This means there are two vital factors which govern the stability. It follows that a decrease in velocity in a stable orbit would cause the electron to move closer to the nucleus until a new state of equilibrium is reached.

An orbital electron cannot maintain a steady velocity because of the presence of other orbital electrons whose distances apart are continuously fluctuating. This means that electrons are continually escaping from atoms and being recaptured by adjacent or nearby atoms. (Incidentally, such factors partially account for the number of free protons found in outer space and in the Van Allen Radiation Belt where atoms are widely separated). As a result, electrostatic field effects around atoms are rapidly changing according to a definite pattern. The greater the number of fundamental particles, the more complex this pattern. At the same time the greater the number, the more restricted the motions. It follows that as there are greater and more frequent changes in velocity, the average velocity of the particles will decrease. This means the negative electrostatic field intensity on the periphery of the atom will increase on the average! What effect does this have on the field zones outside the atoms? The nucleus consisting of positive charges are more closely bunched and the average velocity does not change as much as the number of particles increase. Therefore, the zonal effects around the atoms containing more fundamental particles are not as pronounced as with the

smaller atoms and consequently, are more electrically neutral. This accounts for the fact that the cohesive forces binding large atoms together are, generally speaking, no stronger than with smaller atoms, although the areas of contact are greater with the larger atoms.

The same principle can be applied to ether particles. It was shown that the average kinetic energy of the lower ether particles is the same as that of the higher ether particles. This means that collisions or near collisions of like particles tend to occur with the same force regardless of whether they are of the higher or lower ethers. This means that the zonal effects or field intensities around the larger ether particles are less than that around the higher ether particles. This is compensated for by the larger surface areas of the larger particles which results in the same total repulsive forces.

Ether particles of the same kind will interact with each other more readily than with other ether particles because they are moving at the same velocity. A given ether particle will encounter another like particle moving in approximately the same general direction as often as it will encounter one moving in the opposite direction, since the motions are random. This means there will be longer periods where mutual repulsions of great force will occur. As a result there will be more abrupt and greater changes in the direction of motion. Direct collisions never occur because repelling fields cause a sharp change in direction of motion of particles on a collision course. The interaction time of particles of different velocities will be of shorter duration and this time decreases as the difference in velocity increases. As a consequence, there are less abrupt changes in direction of motion. This means that higher ether particles have only slight influence on the motions of lower ether particles and vice versa. Direct collisions never occur between high and low ether particles because of their repelling fields.

This accounts for the ability of the various realms of high frequency matter being able to interpenetrate or occupy the same three-dimensional space with each realm seeming to have no influence on the other. This does not mean, however, that overall attraction forces are completely absent between realms. When huge concentrations of matter are present these minute forces or influences become great enough to bind the various realms together into the same space. This prevents the realms of high frequency matter around a planet from becoming separated.

The picture of the ethers just presented reveals a principle of widespread ramifications. The average distance or mean free path between ether particles of the same kind has been shown to be a constant regardless of the ethers involved. This represents the most basic unit of linear measurement in the entire universe. Also, since the average kinetic energy of all ether particles is a constant, the most fundamental unit of energy can be stated. In terms of gram-centimeter units, the average kinetic energy of an ether particle in ergs represents this basic unit. Since all manifestations of energy and energy interactions involve ether particle bombardments, it follows that all energy interactions including light will occur in whole number multiples of this unit! This means that energy exists in discrete amounts or bundles of energy instead of a continuous flow as the world of science believed prior to 1901. It was not apparent in ordinary measurements because of the minuteness of this constant. Finally, in 1901, Max Planck discovered this reality in an attempt to explain the distribution in frequency of the radiant energy in the cavity of a body (black body radiations) as a function of the temperature of that body.

Planck found that he could derive the correct law of distribution only by assuming that energy exists in discrete units of energy,  $Nh\nu$ , where  $N$  is an integer and  $\nu$  is the frequency of the light involved and  $h$  is some universal constant. In order for the energy equations to balance,  $h$  is expressed in terms of energy multiplied by time or erg-seconds and is known as Planck's constant. This happens to be the same constant mentioned above except that it is expressed in ergs instead of erg-seconds. The numerical value is the same in both cases. The value of this constant has been determined empirically to be  $6.6 \times 10^{-27}$  erg-seconds.

Einstein later used this constant to allegedly explain the photoelectric effect. It was found that the maximum kinetic energy of electrons dislodged from surfaces by light was not dependent on the intensity of the light, but was a function of the frequency. The kinetic energy was directly proportional to the frequency of the light employed. Einstein reasoned that a light photon gave up its energy to an electron, and, therefore, the energy of a light photon was directly proportional to its frequency, according to the relation  $E$  equals  $h\nu$  where  $\nu$  is the frequency of the light and  $h$  is Planck's constant. Indeed, this relation did fit the experimental facts and Einstein received the Nobel Prize about 20 years later for this specula-

tion. Although Einstein gave the wrong reasons, it is not surprising in view of the above conclusions that his photo-electric equations conformed with the facts. However, the type of reasoning Einstein employed showed that his scientific peccadilloes were not confined to the Theory of Relativity.

In fact, Einstein's conclusions were as usual, contrary to the facts. As will be shown later, the kinetic energy of a light photon is inversely proportional to the frequency. The lower frequency light, consists of larger and more massive photons traveling at the same velocity as the higher frequency photons. It is incredibly bad logic to assume that only one photon would collide with an electron. Each electron ejected, would be bombarded with a barrage of countless photons. The fact that the kinetic energy of the ejected electrons is directly proportional to the frequency of the bombarding light, is in perfect harmony with what has been presented in regard to the nature of the ethers, and other concepts to be presented later. Light of any given frequency, follows identically, the same pattern as light of any other frequency. This means that on the average, the number of photons in any given ray, and the number of soft electrons accompanying it, will be a constant, regardless of the frequency. This is in accordance with the conclusion that the average distance, or mean free path between ether particles of the same kind, is a constant, regardless of the ethers involved. The average number of photons comprising a soft electron, will also be independent of the frequency. This means the diameter of surface area of a soft electron, will be inversely proportional to the frequency. As will be shown in the next chapter, soft electrons accompanying light, travel at a velocity less than that of light. The soft electrons pick up speed, by bombardments of faster moving photons.

From a superficial glance, it seems that the average velocity of soft electrons should be independent of the frequency of the light associated with them. Such is not the case. The soft electrons associated with the higher frequency, travel at a higher velocity, and herein lies the key to the photo-electric effect. Although the lower mass of the higher frequency soft electrons, is offset by the lower kinetic energy of the bombarding higher frequency photons, the surface area is greater in proportion to mass. This means that in proportion to mass, the electrons associated with the higher frequency light will receive a greater bombardment of photons and thus a greater accelerating force. The ratio between surface area, and volume or

mass, is inversely proportional to the ratio between surface area, and volume or mass, is inversely proportional to the ratio between the diameter of two given spheres. Since the other factors balance out, it follows that the resultant average kinetic energy of soft electrons in proportion to mass, is directly proportional to the frequency of the light they are associated with. As soft electrons collide with a surface, the hard electrons they contain, are released and bombard the surface. It is these bombarding hard electrons, that produce the photo-electric effect. They will be traveling at the same velocity as the soft electrons that originally housed them. It follows that their average kinetic energy will be directly proportional to the frequency of light! Thus, hard electrons are ejected from the surface with a kinetic energy or voltage, directly proportional to the frequency of the impinging light.

At this point there is a need to clarify a paradox that may crop up later when it is revealed that the inertial properties of hard electrons tend to be nullified when captured by soft electrons. It is the more unstable soft electrons that produce the photo-electric effect, when they collide with the surface involved. Such particles disintegrate and release the hard electrons they contain. The inertial properties of hard electrons are not completely nullified when captured by the more unstable soft electrons. Consequently they acquire a kinetic energy of their own as the soft particles that house them are accelerated.

Planck's discovery and Einstein's speculation laid the groundwork for the development of quantum mechanics, considered the most monumental achievement of 20th Century physics. In view of the principles presented above, it is not surprising that mathematical juggling with Planck's constant would account for many experimental data in a quantitative sense. Quantum mechanics experts have enjoyed considerable success in this respect, especially in the realm of atomic spectra, without knowing why. In reality, quantum mechanics does not even qualify as a theory or a concept. It is merely an attempt to give mathematical descriptions of certain phenomena with Planck's constant and his valid assumption as a starting point. Modern "theoretical" physicists have absolutely no conception of why their mathematics agree with certain experimental results. Yet, they have led themselves to believe that by giving mathematical descriptions of such phenomena, they have actually explained them. This is as peculiar a mental process as "doublethink". They are like children playing with a sophisticated mechanical toy they do not understand.



Although the properties of a gas were employed to gain some of the insights into the nature of the ethers, it is expected there will be significant differences between the two mediums. In addition to being infinitely smaller than gas molecules, ether particles are also infinitely more active and are more scarcely distributed throughout space, proportionately speaking, than all but the most rarefied gases. It now becomes evident, why a mass can travel through space at a constant velocity, and encounter no decelerating force. The ether particles are so active, that the closing forces at the back of the moving body, tend to equal the resistive forces, encountered at the front. The rear portion creates a temporary void, which is rapidly filled in by the surrounding ether particles, producing an effect akin to the Coanda Effect, or cloud-buster effect, to be described later. During the filling-in process, the fundamental particles, comprising the rear portion of the body, are bombarded with ether particles, traveling at a higher velocity than is normal. Also, the ether particles of which the mass is comprised, are so sparsely distributed throughout space in a relative sense, a condition analogous to a great mass, traveling through a highly rarified atmosphere exists.

Despite this relatively thin distribution the total pressure they exert on a single electron is over 14 dynes. This will be shown in a later chapter. It represents a pressure almost incomprehensible, when the minute dimensions of an electron are considered. It will be come increasingly apparent in the pages to follow that the concept of the ethers just given makes possible simple and complete explanation of phenomena that would otherwise remain hopelessly unresolved.

Also, the relationship between Planck's constant, the charge on a fundamental particle and other values such as the velocity of light, which has long been the dream of physicists, will become evident. This chapter has demonstrated the power of the 2nd Hermetic Axiom. It demands that the properties of the ethers be reflected in the external universe or the planes of existence. This great axiom has been known for thousands of years but, unfortunately, it does not seem to have been employed with effect by thinkers of the past.



# THE PROPERTIES OF LIGHT

Although Maxwell was highly successful in predicting some of the properties of light, he made an erroneous assumption during the derivation of the famous Maxwell equations which are the foundations of his theory. One of his assumptions was that charges can be neither created nor destroyed, or that the charge on an electron or proton is a constant. It has already been shown that this result is a violation of the law of conservation of energy. This false assumption, in conjunction with the valid assumptions Maxwell made, resulted in a theory consisting of truths mixed with fallacies, some of which will be discussed shortly. The most remarkable aspect of the Maxwell Theory was the conclusion that the velocity of light is equal to the ratio between electromagnetic and electrostatic units of charge. The truth of this highly interesting relationship will be demonstrated later.

The means by which photons are produced will now be made clear. During the creation of a photon, the ethers in the vicinity are suddenly compressed. Some of the ether particles are forced close enough together to adhere to each other. This aggregate is then propelled outward with great force in a manner similar to a compressed spring being released. This process is shown in Fig. 6a and 6b. This photon reaches a maximum velocity, or the velocity of light, after this accelerating force has been expended, which is applied in a distance equal to the so-called wavelength. This process is repeated in the same region, and another photon is produced which follows the first one, just one wavelength behind. A wide range of ethers are periodically affected during the production of ordinary light. This results in a near countless variety of such particles being propagated in all directions with many different wavelengths. Figure 7 shows a typical light ray and beam of light.

Since many photons are projected in all directions, many collisions will result causing a significant portion to adhere to each other in aggregates.

The great majority of soft electrons are created during fluctuations in light velocity when passing through mediums of varying density and even in its passage through outer space. The slowing down produces a back-up of photons and a consequent combining into relatively huge aggregates.

These aggregates will move much more slowly in the beginning than the free photons. As a result, some photons created later catch up to them and attach themselves to the combinations. The aggre-

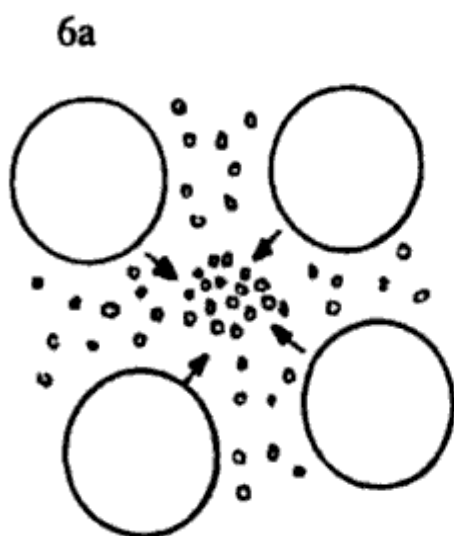

Photons produced by ether particles being crowded close together from all sides by the interaction of hard particles. The more rapid and violent the interactions, the higher the ethers that are affected with the production of higher frequency photons. At the same time lower frequency photons are indirectly created by the indirect disturbance of lower ethers.

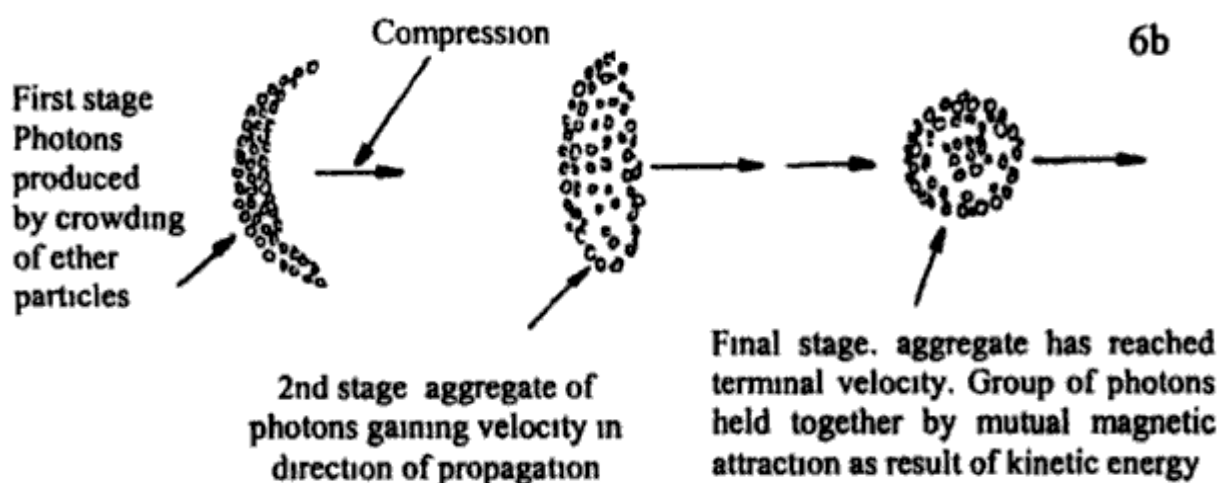

*FIG. 6a: THE CREATION OF PHOTONS*  
*FIG. 6b: THE CREATION OF A LIGHT RAY*

gates then grow larger, and in the process increase their velocity due to these collisions. This is the origin of the particles which always accompany light. It is apparent that the particles formed in this manner will vary greatly in size, stability, and penetrating ability. It has

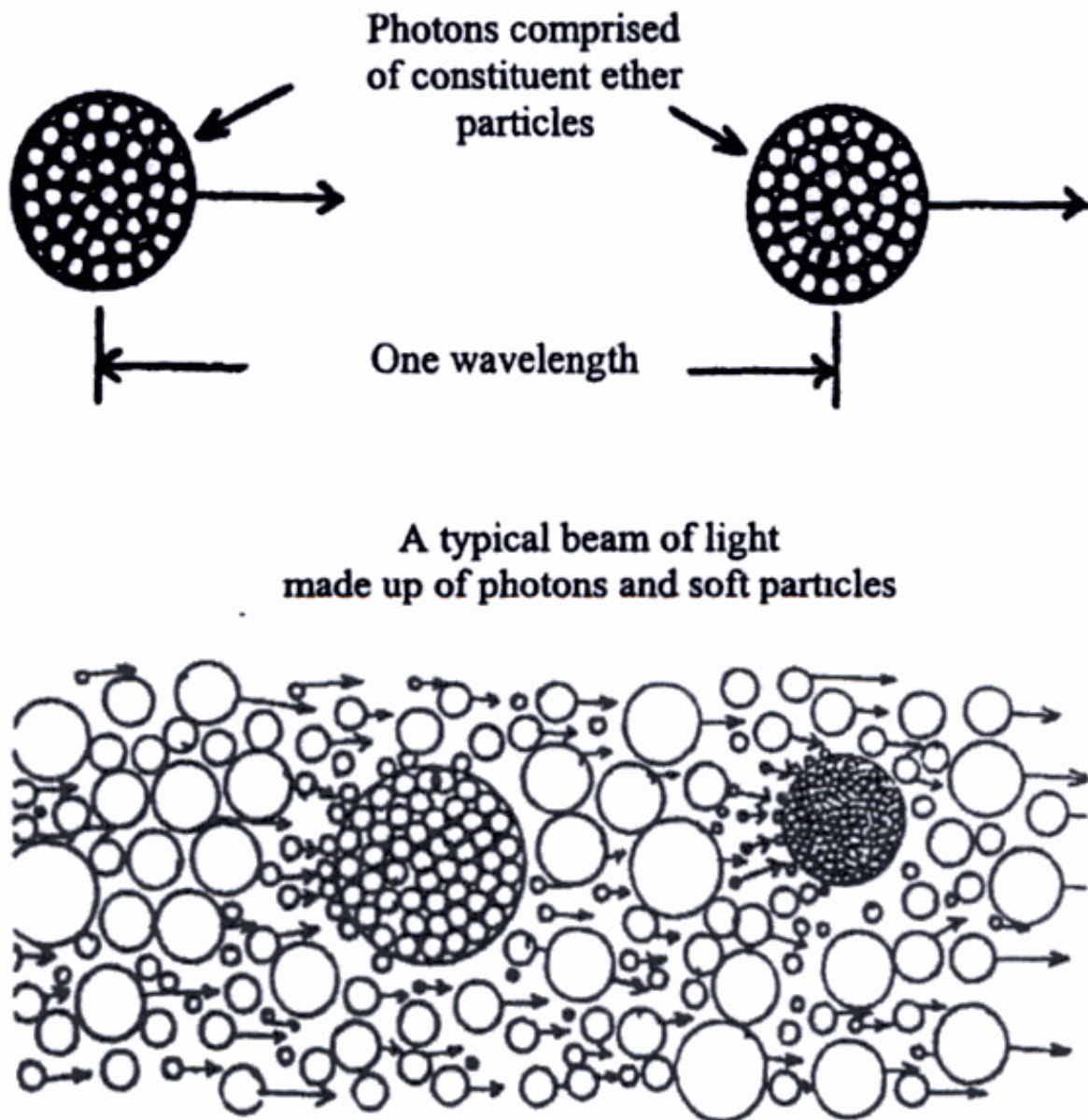
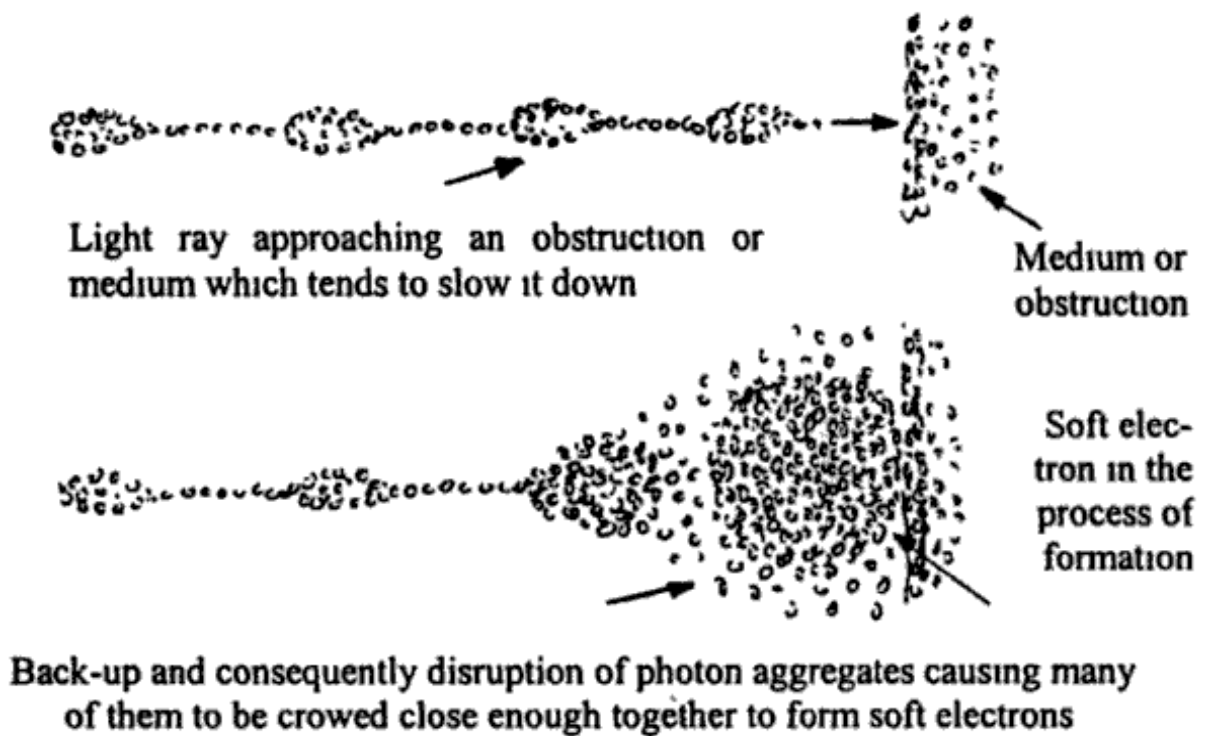

**FIG. 7: LIGHT RAYS, SOFT PARTICLES, AND PHOTONS**

*Soft particles are produced by collisions of photons. The soft particles traveling below light speed continue to grow when additional photons catch up and colliae with the aggregate. A typical beam of light consist of a conglomerate of photons of various sizes. It is produced by combinations of individual rays.*

been shown that soft particles will penetrate ordinary matter more readily than the hard particles.

In the interests of better clarification, the concept of zonal effects and the reason particles are comprised of photons instead of the direct combination of great masses of ether particles should be elaborated upon in more detail. The attractive zone between two particles such as atoms or ether particles is entered when the attractive forces



**FIG. 8: THE CREATION OF SOFT ELECTRONS**

*The above is a greatly simplified version of how a soft electron is produced. The converging of many different rays is no doubt involved in the production of a soft electron. In general any thing that tends to slow down the progress of electromagnetic radiations causes the necessary backup of photons aggregates which results in the formation of soft electrons. This is the manner in which all soft electrons are produced. Since there are any number of ways this can occur, from the reflection of light from mirrors to light encountering particle concentrations in outer space, there are any number of ways soft electrons are produced.*

between unlike charges existing in the particles exceeds the repulsive forces between the like charges comprising the particles. Conversely the repulsive zone exists in the region where the sum of the repulsive forces exceeds the sum of the attractive forces. The attractive zone occupies only a relatively small region of space close to the particles while the repulsive zone is extended for considerable distances beyond the particles involved.

The attractive zones around ether particles extend for a definite but very limited distances beyond the particles. When a small number combine, the attractive zones are expanded and more intense. In other words, the resultant field is expanded and has a higher intensity than that which exists around a single particle. However, as the aggregate becomes larger, this field intensity reaches a maximum and does not become any greater as the number of particles comprising the aggregate increases. The principle is identical to that of combining magnets. For example, consider wafer magnets magnetized through the thickness. The magnetic intensity at the surface of two such magnets joined together is greater than that which exists at the surface of a single magnet. As more magnets are added, the magnetic intensity reaches a maximum and remains a constant regardless of how many more are added. A large aggregate of such magnets will tend to break up into a series of aggregates, if disturbed or dropped, each of which is comprised of an optimum number of individual magnets. This principle is demonstrated in the domain structure of magnetic materials. It has been found that individual atoms or molecules of a magnetic material combine to form separate structures or aggregates which seem to function independently of the others. They behave like separate magnets and the material is magnetized by the alignments of these separate domains. After an optimum number of particles is reached, any increase in the number of magnets means a less stable structure because similar forces are required to hold together a far greater mass.

The domain structure of a magnetic material will find its counterpart in the combination of ether particles to form photons and the combination of photons to form light particles. Thus light particles will disintegrate into photons. Once again we see the Second Hermetic Axiom, underlying the similarity.

Atoms are comprised of hard particles, which are uniform in size and structure, and it is vitally important that they are. If there were no uniformity, matter would be unstable, and chaotic conditions would



result throughout the universe. This indicates that they were created by intelligent design, by the Logos. It follows that they were produced by an entirely different process than that by which the particles which accompany light are produced. The fundamental particles of matter were produced directly by great mind power, whereas the particles which accompany light, and those that are created by the interaction of the particles of matter, disturbing the ethers, are produced indirectly by same.

Although hard particles of matter must be uniform, it is equally important that the opposite be the case with soft particles, accompanying light, which are comprised of the photons of this light. A demonstration of this will be given later in the discussion of the role soft particles play in the life processes of a planet.

## **FALLACIES IN THE TRANSVERSE WAVE THEORY OF LIGHT**

A fact extremely adverse to the Wave Theory of Light involves the diffraction and interference effects which should confirm it. It is significant to note that white light produces interference and diffraction patterns when cast on screens. Since many different wavelengths are involved in each bundle, interference effects should compensate, and as such no dark areas should occur on the screen when white light is used.

However, the apparent interference phenomenon is made possible because the light employed is dim, and consists of a limited number of rays or bundles when it transits through small holes or narrow slits. This light also contains a higher percentage of soft particles because the conditions under which they are produced favors their creation. When light enters a diffraction grating or small hole, more photons tend to be crowded together, which forms unstable soft particles. When light rays approach each other near a screen, they tend to be drawn together by mutual magnetic attraction. This is due to the kinetic energy of the particles in the rays. This attraction, which produces a concentration of rays, also leaves a void on either side, because of the limited number of rays. Similar concentrations are produced nearby in the same manner. The interference effects of light are demonstrated in Figure 9.



This concentration effect exists to some extent with normal light propagation, but it is not as noticeable, since in those cases there is a random distribution, and smaller bundles are formed. We see here why it is extremely difficult to separate light into narrow frequency bands. The regular "diffraction" and "interference" patterns result from near equal angles of convergence of the light rays along definite lines. Hence, there is a critical angle beyond which converging rays will not join. This limits the areas in which the light patterns can develop.

Another significant phenomenon that confutes the Transverse Wave Theory but is in perfect harmony with concepts already introduced is the fact that light slows down in passing through a medium and immediately resumes its original velocity after leaving that medium.

When light enters a medium, it encounters a conglomerate of soft particles created by the activities of the fundamental particles of the atoms comprising that medium. (It will be shown later that it is these particles which enable matter to become visible). This slowing down of the light causes these particles of light to crowd together inside the medium. This action is analogous to a compressed spring released suddenly. If a light beam enters a medium at an angle, the portion entering first, will travel a shorter distance than the rest of the beam during the same interval of time. The beam would have almost completely dispersed if it were not for the mutual magnetic attraction of the particles comprising that beam. Hence, the portion of the ray entering the medium later is pulled toward the side which reached the surface first. This causes the ray, or beam, to be bent or to change its direction. This accounts for the refraction of light, which has never before been adequately explained. Higher frequencies of light are refracted more than the lower frequencies. The higher frequency light is more closely associated with the ethers which comprise the soft particles, impregnating that medium, than is the lower frequency light. As a result, the higher frequencies interact more readily with that medium and, consequently, lose more velocity.

As a ray of light passes a given point, it will experience a periodic rarefaction and condensation of photons and, to a lesser extent, soft electrons. This is analogous to sound traveling through the atmosphere. From this follows that light has the properties of longitudinal waves and not transverse waves.

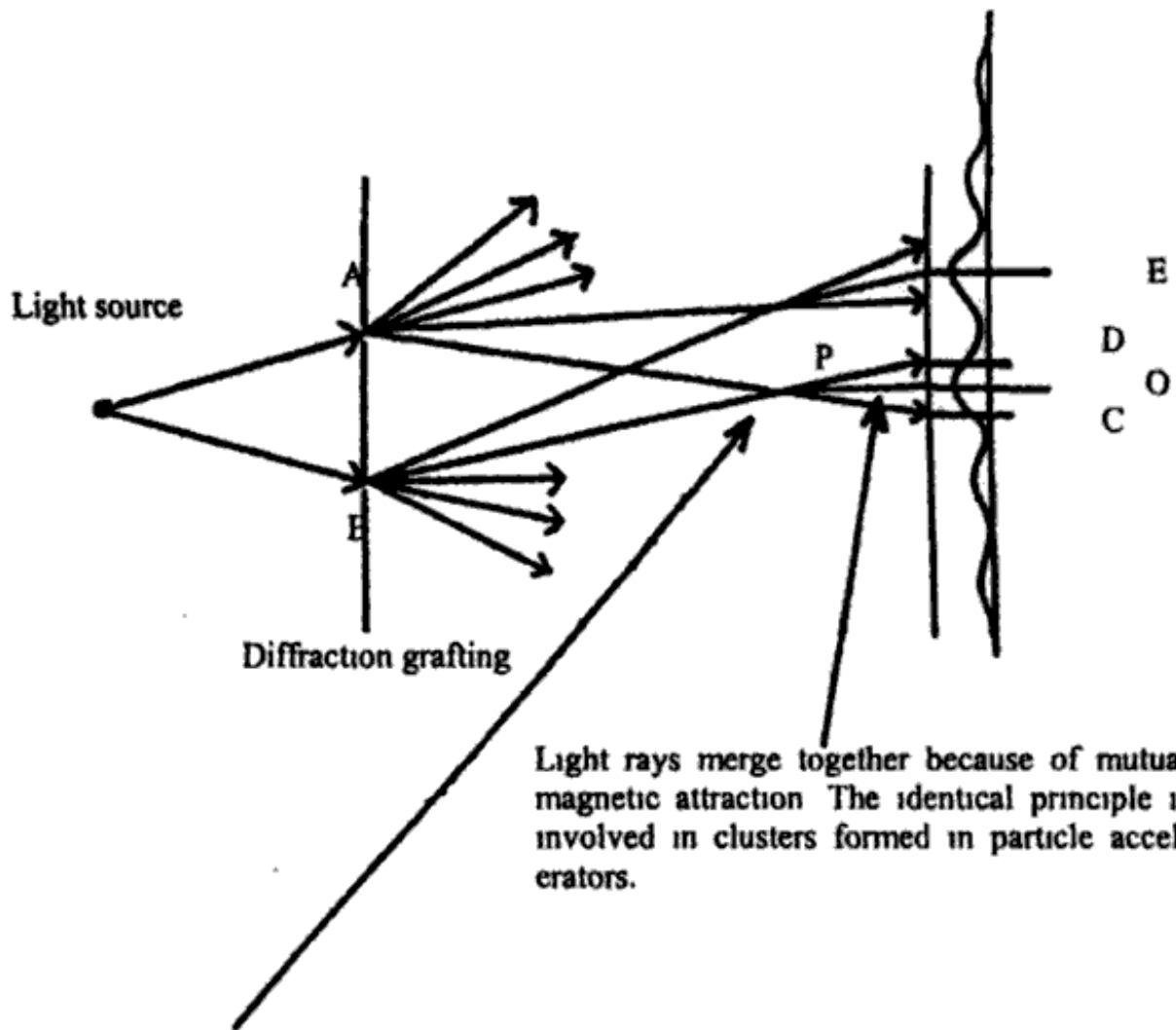

Point P, where the rays of light or soft particles from A and B merge at sufficiently acute angles so as to combine and hit the screen at point O. Points C and D indicate where separate rays would have collided had they not merged. Similarly, point E represents the point where the next bright area occurs due rays from A and B converging at sufficiently acute angles. This principle is involved in all interference and diffraction effects of light and particles. This effect is observed with light comprised of many different frequencies. If the wave theory were valid, interference effects would only occur with monochromatic light or light within a narrow frequency band.

**FIG. 9: THE INTERFERENCE EFFECTS OF LIGHT**

## **RESOLVING THE FAMOUS WAVE-PARTICLE PARADOX**

Beams of electrons, protons and even atoms produce the same interference and diffraction effects as light. This gave birth to the wave mechanics theory of orthodox physics and the electron microscope. The higher speed electrons give the illusion of shorter wavelengths and are more effective in electron microscopes than slower moving ones. This is because more of their electrostatic potential has been transformed. This reduces the repulsive forces between electrons in a given ray, causing them to be more closely associated. Also, such beams are not as easily diverted from their paths, and since they are much smaller than soft electrons, they will have much a greater resolving power. The wave-particle paradox turns out to be another of the many illusions modern theoretical physicists have been unable to properly interpret. The apparent interference and diffraction effects of various particle beams should have told them immediately that the Transverse Wave Theory of light was in error. This became obvious when cloud chamber experiments showed conclusively that electrons and protons, as well as atoms, were particles and only particles. But, as shown in Part II, the famous Michelson-Morely Experiments actually disproved the Wave Theory.

Despite the evidence of the cloud chamber experiments, physicists still cling to the belief that electrons and other particles can be both waves and particles, and that they have no definite location at any instant. This is in direct contradiction to the evidence staring them in the face. Consequently, an orbital electron is assumed to be only a cloud surrounding a nucleus. Here again, their peculiar ability in the art of doublethink has been clearly demonstrated. And as defined previously, doublethink is the ability to accept two mutually contradictory ideas simultaneously.

### **THE NATURE OF POLARIZED LIGHT**

The phenomena involved with polarized light also conform with the principles already stated. The simplest of these phenomena oc-

curs when light, after passing through certain types of crystals such as nicol, becomes almost obliterated when it encounters a similar crystal. Polarization of light has allegedly been explained by the Electromagnetic Theory of Light. This concludes that light consists of transverse waves vibrating in all planes perpendicular to the direction of propagation. It also concludes that light consists of a magnetic portion and an electrostatic part. These different portions are supposed to exist in planes perpendicular to each other. A conclusion is derived from Maxwell's equations, which is in error, because it is based upon the assumption that charges are neither created nor destroyed, and hence that their charges remain constant. This error of charge conservation becomes more apparent in the electromagnetic wave equations derived from this fallacy. It describes an impossible situation with regard to so-called light waves. They refer to the magnetic and the electrostatic portions being isolated from each other.

Polarizing crystals consist of layers of molecules laid down in an orderly fashion. The areas between these layers allow the visible portion of the light to pass through more readily than it does through the rest of the crystal. As with diffraction gratings, photons entering these areas are forced together, forming a much higher percentage of soft electrons than usually accompany light. The resulting sheets of light emerging tend to maintain this planar shape, since they contain a high concentration of soft electrons held together by their magnetic fields. It should also be noted that photons also produce magnetic fields since they are highly stable rotating particles traveling at light velocity, and thus play an important role in holding the sheet together. When this light encounters another crystal with layers of molecules, perpendicular to the plane of this crystal, most of the light is scattered and dispersed before it can emerge from the crystal. The soft particles formed in the manner described, are highly unstable, and, therefore, will be dispersed more easily when they encounter a crystal oriented in this manner. The photons comprising the sheet are also easily dispersed because of their relatively large surface area and low mass.

## CHAPTER 10

# THE NATURE OF ELECTRONS, PROTONS AND ELECTROSTATIC FORCES

It must be realized that nature's laws are basically simple. To gain a deeper understanding of the nature of electrons, protons, and electrostatic forces, it is necessary to look for an uncomplicated picture of the fundamental particles and the cause of their behavior patterns. In accordance with the Hermetic AXIOMS, the same rules apply in the realm of the microcosm, as in the macrocosm. Consequently, the collision laws involving the molecules of a gas can be applied to the ethers. Also, it can be deduced that electrostatic forces are the result of an imbalance of ether particles bombarding fundamental particles of matter.

As in a gas, the motion of ether particles in free space is random. In other words, there is no preferred direction of motion for any ether particle. The analogy with the gas ends at this point. The mean free path of the ether particles directly involved with the electrostatic forces is enormous compared to the diameter of the particles. The repulsive forces between ether particles are so great and their velocities so colossal they do not need to be tightly bunched together throughout space.

The random motion of the ethers is disturbed when they encounter a surface such as that of a fundamental particle. Consider, for example, the vertical surface A shown in Figure 10a. The presence of this surface disrupts the random motion of these particles due to collisions with the surface. The resultant disturbance of this random motion depends on the mean free path, or the average distance a particle will travel in free space before colliding with another particle. The greater the mean free path, the greater the random motion will be for the particles that have been disturbed for any given distance from the surface.

When two surfaces such as A and B are adjacent to each other, as shown in Figure 10b, each surface will receive a greater bombardment than it would if the other surface were not present. It would



then seem logical to assume that electrons and protons have a spherical shape, since the sphere is the most stable and efficient geometrical form. It also has the smallest surface area in proportion to volume. However, such an assumption leads to insurmountable difficulties. Electrons and protons have a preferred direction of spin in relation to their direction of motion. The electron follows the left hand rule, while the proton spins according to the right hand rule. With a perfect spherical shape they could not have any preferred direction of spin. But, the preferred directions can be readily accounted for, if the particles are pear or egg-shaped, and are also hollow. This will be discussed in more detail later in this chapter.

When ether particles have a preferred direction of motion away from the electrons due to reflections, a pulsating electric field results. The excessive flow away from the electron tends to reduce the bombardment of incoming ether particles. A temporary low ether pressure around the particle ensues due to the bombardments. Reflections are reduced, and the outside ethers then move in to compensate for this low pressure, and a sudden increase in ether bombardment is a result. This is something akin to the Coanda Effect. The cycle is then repeated. It is to be expected then, that an electrostatic field is no exception. In this respect the term "electrostatic" is a misnomer.

Two electrons in the vicinity of each other will repel each other with a fluctuating repulsive force. It is not likely that the fluctuations around any two particles would necessarily be in phase. The phase relationship depends on the previous history of the two particles in question, and their interactions with other particles, as well as their origination. The average repulsive force remains virtually the same, regardless of their phase relationship. This has been confirmed by an experiment which determined the charge on a hard electron. The force gives the illusion of being steady due to the ultra-high frequency of the cycles. Figure 10d depicts the fluctuating repulsive force between two electrons.

Since the proton was created by some highly intelligent design, it follows that the proton, as well as the electron, must be a masterpiece of precision. If it has the same basic outline as the electron, yet produces different electrostatic effects, it must have a different

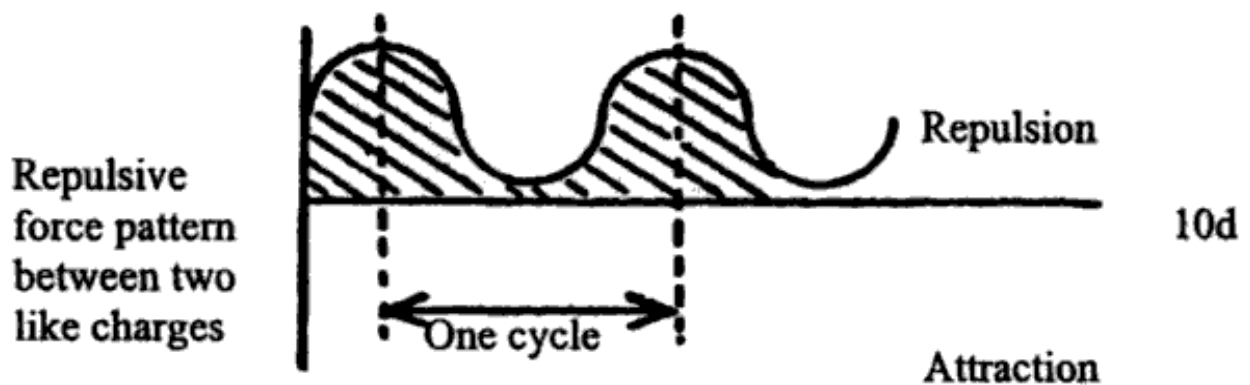
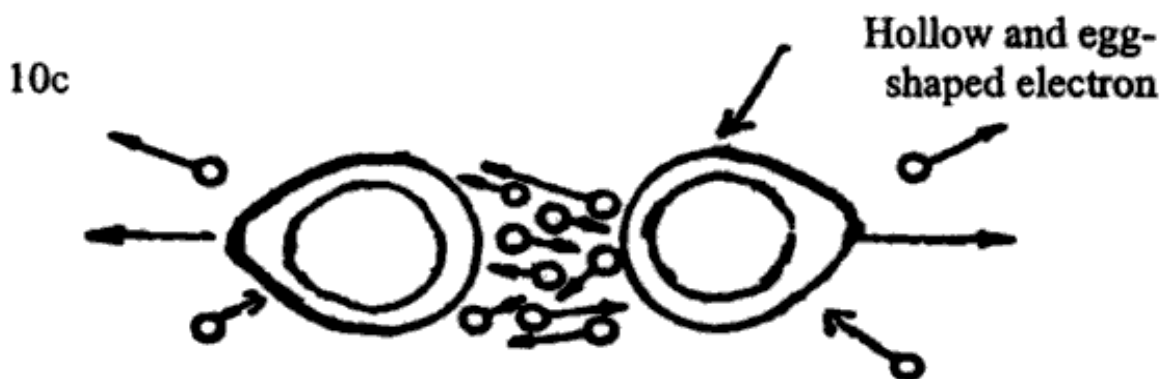
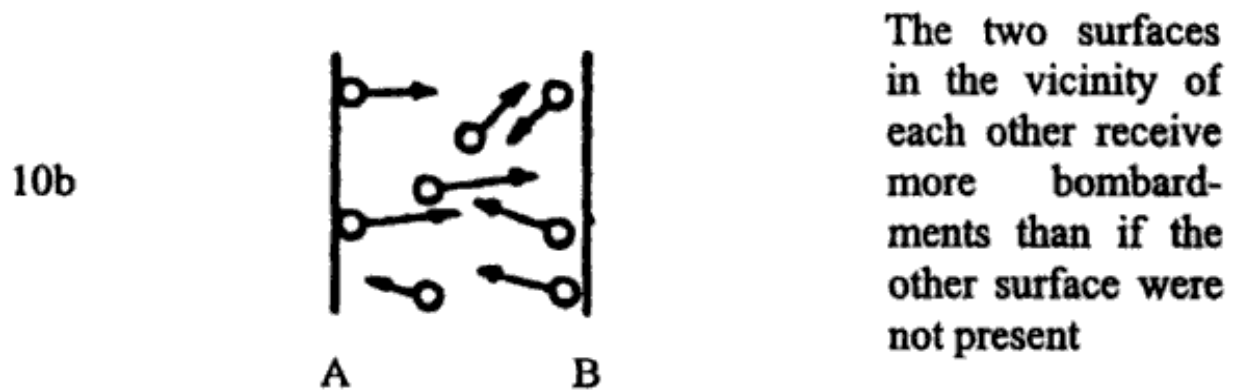
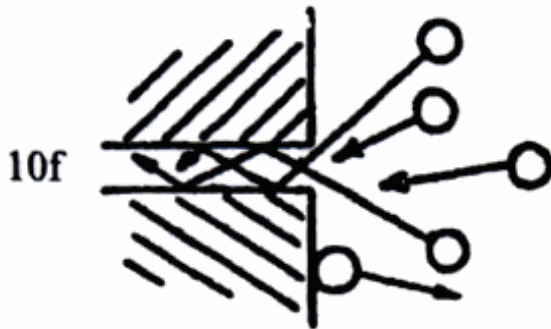

FIG. 10: THE STRUCTURE OF THE ELECTRON AND PROTON



Egg-shaped proton

The structure of the proton is depicted with a myriad of tiny holes. In this figure the proton is inhaling ether particles into its hollow core.



A surface with a hole disrupts the random motion of the ethers. Many ether particles are captured by the hole as indicated by the arrows.

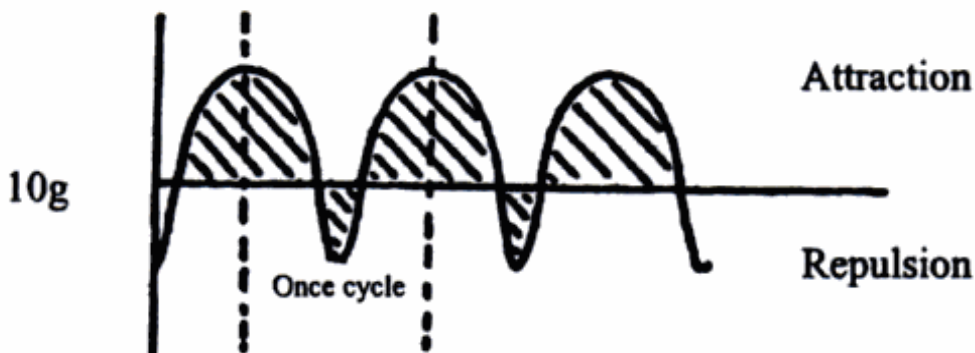

Attractive force pattern for unlike charges

**FIG. 10: THE STRUCTURE OF THE ELECTRON AND THE PROTON (CONTINUED)**

surface and internal structure. Economy and efficiency are two of the attributes of good design. A hollow condition for both electrons and protons would indicate such a plan. Less material would be required for their creation, and at the same time, they would be more maneuverable due to lower mass. The other reason for the hollow condition will be discussed shortly.

Figure 10e shows a cross-section of the proton and its effect on the ethers surrounding it. The diameter of the holes in relation to the proton diameter is somewhat exaggerated. The total area of holes is much greater than the reflective surface area on the outside. Also, the particle must have a hollow center. These properties were deduced in order to account for the behavior of the proton. These concepts are also necessary to account for the gravitational forces which will be explained in the next chapter.

It will now be shown that the field surrounding a proton is also cyclic. Consider a surface with a hole, as shown in Figure 10f. The random motion of the ethers is not only disrupted, but many ether particles are temporarily captured, as indicated by the arrows. It follows that most of the ether particles colliding with the proton will not be reflected, but will find their way into the interior. This continues until the concentration of ether particles in the interior reaches a critical stage. Then a sudden discharge of ether particles through the holes results. This is analogous to the function and behavior of a geyser. The field effect around the proton is therefore cyclic. During the build-up of ether pressure inside, there are relatively few reflections of ethers from the surface. The ether pressure around the particle is, therefore, comparatively low during this period.

The repelling force between protons can be resolved from the following considerations: The discharges produce a greater bombardment on other protons in the vicinity for a relatively brief period of time than they would normally receive from the surrounding ethers. The discharged particles between adjacent protons produce a greater pressure on the sides facing each other than occurs on the opposite sides. This is because they are temporarily trapped between the particles. The characteristics of phase relationship and average repelling force are the same as in the case of the electron depicted in Figure 10d.

Electrons and protons tend to attract each other. Therefore, the average ether pressure is less on the sides facing each other than on opposite sides. As previously stated, the proton can be likened to an entity that breathes in and exhales ether particles. The electron is drawn toward the proton during the inhaling process and tends to be repelled during the exhaling. If it were not for other factors to be considered, this would indicate that the repulsion and attraction forces would cancel out to a net average force of zero. But this is not

the case. The period of inhalation is considerably longer than the period of exhalation.

During the inhalation, many of the ether particles that would normally collide with the electron have been captured by the proton. This results in a very strong attraction of the electron toward the proton. A high concentration of ether particles is propelled toward

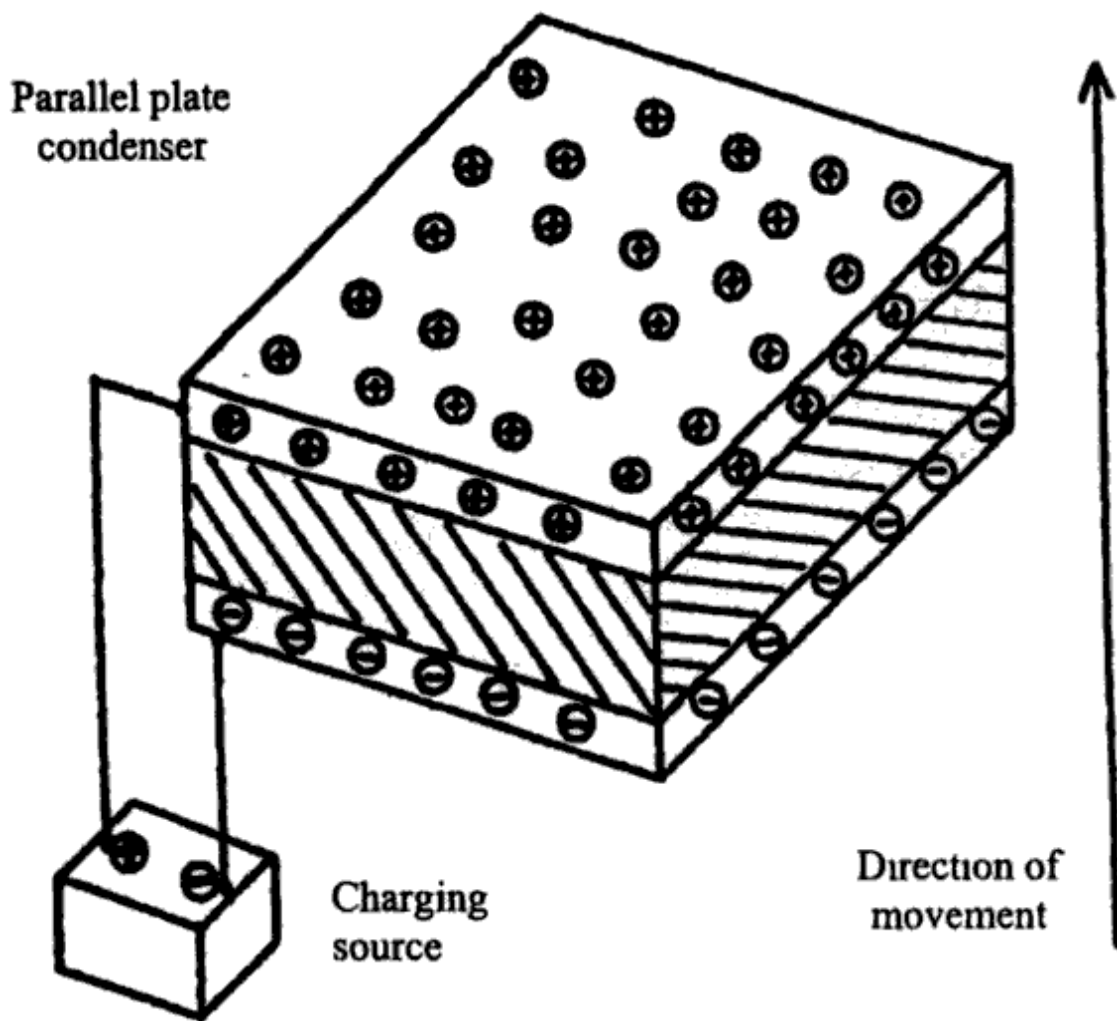

*FIG. 11: THE BIEFELD-BROWN-EFFECT*

*The Biefeld-Brown effect is due to the greater tendency for an electron to move toward a proton than vice versa. This causes a parallel plate condenser to have the tendency to move in the direction shown.*



the electron when the proton exhales. However, only a fraction of the ether particles ejected toward the electron actually collide with it. The high concentration causes many particles to collide with each other and scatter in directions away from the electron. This indicates the average repelling force, multiplied by the time during which it occurs. This is considerably less than the product of the average attracting force and its time of action. The total net average force is then that of the attraction, as depicted in Figure 10g.

The existence of the cloud of ejected ether particles between the electron and proton, during part of the cycle explains why the electron never makes contact with the proton to form an electrostatic dipole. Ejected ether particles exert a tremendous repelling force on the electron if it is too close, and the ejected particles are not as readily dispersed. Therefore, the zone of attraction for electrons and protons does not include areas close to the proton. There has been much speculation as to why protons and electrons never combine to form a dipole. It was assumed a mysterious repelling force existed that acted for very short distances. The neutron, or collapsed hydrogen atom, exhibits the closest approach of electrons to a proton.

Due to the structure of the electron and proton, it follows that the electrons have a far greater tendency to be drawn toward the proton, than the proton toward the electrons. This is because the ether pressure on the opposite side of the electrons is always greater than that on the opposite side of the proton.

This tendency means that in a charged parallel plate condenser, the negative charges will have a greater tendency to move toward the positively charged plate than vice versa. Therefore, an unbalanced force exists, causing the condenser to move in a direction from the negative plate, to the positive plate as shown in Figure 11. This phenomenon is known as the Biefeld-Brown effect. T. Townsend Brown was issued patent numbers 2,949,550, 3,022,430, and 3,187,206 for a possible space drive based on this effect. The author found this effect to be quite pronounced when he charged such a condenser to 50,000 volts. What has been the scientific community's reaction to this highly significant phenomenon? The average reader already knows without further elaboration. They ignored it. Is this due to a myopic vision and retarded awareness, or the obvious likelihood that they are more concerned about maintaining the status quo of science than in discovering truth? Perhaps it is a combination of both.



Several questions now arise concerning electrons and protons. Is there a great disparity in their relative sizes? Does the charge on the proton have the same magnitude as on the electron? Does the proton have about 1836 times the mass of the electron as physicists claim?

The behavior of beams of electrons and protons in strong magnetic and electric fields does indicate that protons have about 1836 times the inertial mass of electrons. In this rare case, the conclusions of the physicists are valid, but they lacked the insight to take advantage of this highly significant fact. It has already been shown that inertia is dependent on charge and that inertia is directly proportional to charge. This means that if the proton has 1836 times the inertia of an electron, then its total charge is 1836 times as great as that of the electron! Physicists have always assumed that the charges were equal and opposite. Interestingly enough, the charge on the electron has been measured directly, but this is not the case with the proton. They assumed this equality because of the apparent neutrality of the hydrogen atom. The idea that the hydrogen atom consists of one electron and one proton has never been questioned.

Another interesting conclusion can be derived from the above. The total energy of the magnetic field around a moving proton is 1836 times as great as that around an electron traveling at the same velocity. This means that the volume of space occupied by the magnetic field of the proton is at least 1836 times as great as that of the electron. It is logical to assume that for a given velocity, the proton, due to its perforated condition, must be considerably larger to produce a magnetic field of a given total energy than it would without the holes. It is then safe to conclude that the proton is more than 1836 times as large as the electron. All of this of course, is based on the assumption, that the "proton" used in the experiments were completely free of electrons. This is not the case. It is next to impossible to produce a beam of protons completely free of electrons. This has been unwittingly demonstrated by particle physicists, in cloud chamber experiments. To quote from a science magazine: "When protons crash into each other, they release showers of electrons, which suggests that protons are made up of particles more basic than themselves." It follows that the charge on a stripped proton is much greater than 1836 times that of an electron. It is still an unknown quantity.

On the basis of relative charge effects alone, it follows that a hydrogen atom, instead of having only one electron orbiting a proton,

there are at least 1836 orbiting electrons. However, since the proton has relatively little movement in comparison to the electron, a far greater percentage of the electrostatic field of the electron has been transformed. This means that in order for the hydrogen atom to have close to a neutral charge, there must be thousands of electrons comprising the hydrogen atom! This seems to create a paradox. The amount of electricity required to liberate a given amount of hydrogen in electrolysis indicates that only one electron is necessary for every atom of hydrogen. It apparently confirms the idea that the hydrogen atom has only one electron.

Scientists have never comprehended the source of the electricity that powers electrical equipment. Later, it will be shown that there are unlimited quantities all around us, and that they permeate all known space. This hard electricity is camouflaged by softer particles also distributed throughout space. The flow of this limitless source of electrons can easily be set into motion! The electricity employed in electrolysis merely triggers the flow of far greater quantities. Also, when a hydrogen atom is ionized, it only needs to lose a very small percentage of its electrons, instead of being reduced to only a proton.

Electrolysis, the process of ionization and dissolving of substances in a solvent, the difference between a chemical bond and cohesion, and other aspects of chemistry will be explained in more detail later.

It would be difficult, if not impossible, to account for the phenomenon that hydrogen continuously radiates soft electrons on the basis of steady and uniform electrostatic fields and also the idea that the hydrogen atom has only one electron. If this were the case, hydrogen could not radiate except by thermal agitation. The cyclic electrostatic fields and the myriad of orbital electrons produce oscillations, even if hydrogen is cooled to zero degrees Kelvin. This disturbs the ethers with the creation of soft particles.

Matter is rendered visible by the steady formation of soft particles, generated by the activities of the fundamental particles. It is then apparent that frozen hydrogen would be completely invisible if electrostatic fields were not cyclic and the hydrogen atom had only one electron! Cyclic electrostatic fields are largely responsible for the complex, spectral pattern of all the elements. The atom is not a lifeless entity, but a pulsating, living thing. It is guided by a creative intelligence as all things are.

A more detailed explanation of the manner in which soft particles are produced by the activities of the fundamental particles of atoms is in order. It seems a paradox that hard particles are able to disturb far lower ethers than those with which they are directly associated, since they are oblivious to direct interactions with those lower ethers. This disturbance of the lower ethers is produced indirectly by the hard particles. The normal frequency of interaction of hard particles is much too high to disturb the lower ethers sufficiently to produce soft particles. However, slightly lower ethers are directly disturbed, which in turn disturb ethers slightly below them. This pattern continues until the ethers are disturbed which correspond to the frequency of soft particle interactions. This results in the creation of soft particles associated with these lower ethers.

The cyclic pattern of hard-particle interactions is complex. This complexity increases rapidly as the number of fundamental particles in the atom increases. This means many different lower ethers are indirectly affected with the consequent production of many kinds of soft particles. Interestingly enough, there is a definite ratio between the frequency of the ethers associated with hard particles, and the ethers associated with the soft particles which render matter visible. Since soft electrons are produced continuously by the activity of the fundamental particles of atoms the spaces between atoms are always permeated with high concentration of soft electrons. Many of these soft particles are associated with the same ethers as those of visible and higher frequency light. Consequently this blanket of soft particles reflect incoming light. The picture of the proton just shown indicates that it will be relatively sluggish, and that in any proton-electron relationship, the electron will do most of the moving.

The charge on a particle is defined as the force it exerts on a like charge or known number of charges a unit distance away. In view of the pulsating characteristics of the electrostatic field around a particle, this definition should be modified by substituting "average force", for "force", in the definition. As stated previously, the frequency of the electrostatic cycle is so great that an illusion of a steady force is the result. This is the average force existing for one complete cycle.

## CHAPTER 11

# ATOMIC STRUCTURE AND THE NATURE OF MAGNETIC FIELDS

Since electrons move at much higher velocities in the atom than protons and cover much more territory, a higher percentage of their electrostatic charge is transformed into magnetic energy. This means that the positive charge in the atom will overbalance the negative charge, and give the atom an overall, positive charge. This explains why electricity tends to move toward ground, and the Earth must possess a positive charge.

The electrostatic field effects near the atom, in close proximity to the electrons, will be negative. Moving outward, this negative effect quickly diminishes and a zone of positive field effects exists. The position and intensity of these zones, therefore, determine in part the chemical and physical properties of the atom. There are regions where the atoms will attract each other and also where they will repel. By once again applying the 2nd Hermetic Axiom, it is seen that ether particles have a similar structure, and follow the same pattern.

The velocity of orbiting electrons in atoms is not uniform. There are periodic fluctuations resulting from mutual interferences within the atom itself and from adjacent atoms, in addition to the pulsating electrostatic fields. It must be noted that the properties of the atom are not observed individually, but as a collective group. The region of activity for the protons is relatively small, and a significant number of electrons are trapped here. This region is the origin of neutrons, which are actually collapsed hydrogen atoms. It is interesting to note that when hydrogen is subjected to ultrahigh pressures, it behaves like a high concentration of neutrons and passes through the container which is being pressurized, as though it didn't exist.

A more detailed discussion on the structure of the neutron is in order. The new concept of thousands of electrons comprising the hydrogen atom, (to say nothing of the other atoms), provides for the first time, a means of accounting for the properties of the neutron. When a cloud of electrons orbiting the proton is forced into close proximity with the zone of repulsion, as described earlier, their motions become restricted. As a result, there is a lowering of the average velocity with a consequent increase in their negative, electrostatic charge. This provides a stronger bond between the proton and the electrons. The orbital speed cannot be increased because of the zone of repulsion surrounding the proton, and the crowding of the electrons. The higher overall negative charge of the electrons almost completely cancels out the positive charge of the proton. The result is a particle that is electrically neutral, as far as most experiments can determine.

The electron cloud comprising the hydrogen atom is further removed from the proton, and the individual electrons are not restricted in their orbital motions. The average velocity is much higher and consequently, the hydrogen atom has a high positive charge. The atoms of the gaseous elements, such as hydrogen and oxygen, are highly magnetic. Therefore, two atoms combine in much the same way as two bar magnets to form a molecule consisting of two atoms. This is the reason the molecules of nearly all the gaseous elements consist of two atoms. The combination has a still higher overall positive charge than a single atom. As a result, the molecules have a strong mutual repulsion which keeps them widely separated at normal temperatures and pressures. Thus, they remain a gas even at extremely low temperatures.

The presence of electrons in the "nucleus", nullifying repulsive forces, and also the magnetic fields resulting from the motions of neutrons, is the major source of the so-called mysterious force, holding the nucleus together. It will be shown later in this chapter that the pinch effect of magnetic fields is the prime force that hold the atom together. Modern, orthodox physicists have complicated the picture by claiming that many different forces exist. This includes magnetic, electrostatic, gravitational, nuclear, and others to which they have assigned odd names. In reality, only electrostatic and magnetic forces exist. In addition, there are two, and only two, basic particles: electrons and protons. This conforms to the Law of Duality.



Since the electrostatic field effects around the electron and proton are cyclic, and the magnetic fields they generate will also exhibit an intensity that is cyclic. This cyclic pattern will be identical in frequency to the electrostatic one. This follows from the dual nature and relationship between electrostatic and magnetic fields.

Despite their stumblings, modern physicists finally managed to make one correct assumption concerning atoms. An atom does consist of electrons orbiting a concentration of positive charges, remaining relatively fixed in relation to the electrons. This, of course, is due to the comparative sluggishness of protons. An understanding of the nature of magnetic fields is mandatory in order to further analyze the structure of the atom.

## **THE NATURE OF MAGNETIC FIELDS**

The electron and proton start to spin in a definite direction when they are given a velocity, but neither one spins when it is at rest. This is contrary to the assertions of modern theorists, who talk about particle spin with reckless abandon. The electron always follows the left-hand rule, while the proton follows the right-hand rule. It is vitally important that these particles are consistent in their behavior, otherwise chaos would reign and matter could not exist.

As stated earlier, the left and right-hand spin characteristics of electrons and protons can be accounted for, if these particles are egg and pear-shaped, in addition to being hollow. When placed in an electrostatic field, they will move in such a manner that the large end is facing in the direction of their motion, regardless of their original orientation. The reason is not difficult to discern. If they are hollow and the shell is of a certain thickness in proportion to diameter, the larger end will have more surface area in proportion to its mass, than will the smaller end. The thickness of the shell at the smaller end will be much greater in proportion to its diameter. This means ether bombardment at the larger end will tend to give it a greater acceleration than that imparted to the smaller end. As a result, the larger end will always be forced ahead of the other portion in the direction of motion.

The picture is still incomplete. In order for the particle to have a preferred direction of spin, the frontal surface must be grooved in the manner of a right or left-hand screw. This design is not expect-



ing too much of the great creative intelligence which created them. Such a shape is consistent with recent experiments at the *Argonne National Laboratory*, which studied the scattering of proton beams aimed at target protons. The results indicated that protons were not spherical. A detailed account of such experiments can be found in an article "The Argonne Experiments and The End of Quarkery" by Eric Lerner which appeared in the Oct.-Nov. 1977, issue of *Fusion Magazine*. The article justifiably made a mockery out of a popular theory in particle physics concerning an ever growing family of hypothetical particles called quarks. This is another product of the mental transgressions of certain particle physicists. The article is well written and the author, as the title suggests, displays a sense of humor that is extremely rare among scientists. Unfortunately, he has not broken all of the shackles of orthodoxy, since he still apparently believes in many of the ideas of conventional physics, such as the existence of neutrinos and other non-existent entities. Despite all this, he has displayed a degree of mental acumen well above the great majority of his colleagues. He presented arguments which confuted some of the basic assumptions of quantum mechanics and showed them to be contradictory, such as the ridiculous idea of point particles, as is claimed for electrons. In other words, it is assumed they are infinitely small.

It has been noted that a magnetic field surrounds a moving charge. The magnetic lines are in the form of circles. An electron or proton tends to carry ether particles around with it in a circular motion as it moves through the ethers. This is due to the mutual repulsion between the ether particles and the ether particles comprising the particle. The action is identical in principle to that of a propeller free to rotate on its axis as it moves through the atmosphere. The reactive forces cause a particle to spin, which at the same time produce a vortex motion in the ether.

The greater the velocity of the particle, the faster it spins and the more ether particles are caused to flow around it in the direction of the spin. It is this flow of ether particles around a moving charge, which produces the magnetic field effects observed. A view of this magnetic field, from a three-dimensional standpoint, shows that it resembles a corkscrew spiral or vortex.

Now, consider two like-particles moving adjacent to each other in the same direction. When they were at rest they repelled each other, because of the unbalanced ether bombardments. As the particles

move, the magnetic flow of the ethers around the particles disrupts the normal electrostatic bombardment of the ethers. Many of the particles that had contributed to the repulsion, now tend to be diverted into a rotary motion around the particles to produce the magnetic fields. All the ethers that could produce a repulsive force are converted into a rotary motion, or magnetic field, by the time the particles reach the speed of light. This has been unwittingly demonstrated by the behavior of particles in an accelerator, as discussed in Part I. This same principle has also been demonstrated by the behavior of two adjacent wires carrying a heavy current moving in the same direction. The wires tend to be drawn together. Cancellation of magnetic flow between the particles tends to occur, and the particles are encircled by these same magnetic lines.

In addition, consider two unlike charges moving along together in the same direction. When they start to move, the unbalanced ether bombardments producing the attraction tend to be converted into a rotary motion, as in the case of the like charges. The direction of spin of the particles in this case are in opposite directions. The magnetic fields between the particles now tend to meet head on, as they try to encircle their respective particles. This produces a magnetic repulsion. This activity also has a tendency to cancel the magnetic effects of each particle when they are forced to remain in close proximity to each other, as is the case with the atom. It will be shown in the next section that this effect also greatly reduces the inertial properties of the atom.

An electron or proton moving in a magnetic field has two forces acting on it. One of these tends to force it down the magnetic lines of force, because of excessive ether bombardments in one direction of flow of the ether particles. The other is perpendicular to the lines of force. If the velocity of the particle is high, the latter force is by far the more significant. It becomes apparent here, by the application of the 2nd Hermetic Axiom, that this force is a result of Bernoulli's principle.

This tendency for particles both positive and negative to travel down magnetic lines is almost self-evident. A so-called magnetic line is the result of a flow of their particles in a preferred direction. It can be likened to a raging stream. Anything that encounters it is captured and swept along with it. Thus magnetic fields tend to capture large quantities of soft electrons. The stronger the field the greater this tendency.

Bernoulli's principle states that the pressure of fluid exerted on a surface decreases when it moves across that surface. The higher the velocity, the lower the pressure it exerts. The molecules of a fluid at rest will bombard a surface in a random manner. The components of these bombardments perpendicular to the surface, represent some resultant pressure. The original perpendicular components start to form acute angles with the surface as the fluid moves. This means that the new perpendicular components will result in weaker forces being exerted in this direction. The higher the velocity, the more acute the angle that the originally calculated perpendicular components make with the surface, and with a lower resultant pressure.

Bernoulli's principle will now be applied to explain the behavior of particles in the presence of magnetic fields, as well as the properties of the magnetic field. First, consider the behavior of a spinning baseball thrown by a pitcher. When the direction of spin is in a plane parallel to the direction the ball is moving, the ball will have a tendency to curve or deviate from its original path. The direction of spin on one side of the ball is in the same direction that it is moving, while on the opposite side the spin is in the opposite direction. This means that on this latter side, the velocity of air flowing across the surface is less than it is on the other side. The air pressure on the side with the lower, relative air velocity will therefore be greater than that on the adjacent side in accordance with Bernoulli's principle. This imbalance of forces causes the ball to deviate from its intended path.

The same identical principle is involved when an electron or proton moves between the poles of a horseshoe magnet, as shown in Figure 12. The direction of motion is into the paper. The direction of flow of the magnetic lines is indicated by the arrows. The reader can see from the direction of spin and the application of Bernoulli's principle that the electron will be forced to the left, while the proton will be forced to the right. This has been confirmed by laboratory experiments for many decades.

Bernoulli's principle is responsible for the pinch effect produced by magnetic fields. When a particle, such as an electron, is given a velocity, the magnetic field that develops around it tends to compress it, much in the same manner as a rope or string drawn tightly around a ball. The faster the electron moves, the stronger the field becomes around it, hence, the greater this tendency. Bernoulli's principle is the primary cause of this effect. The flow of ether parti-

cles around the particle causes a low pressure area outside the flow, and the surrounding ethers on all sides tend to compress the configuration of this flow into a smaller volume. The flow has no place to go except to press tighter against the electron, as shown in Figure 12.

The pressure exerted on the particles from the pinch effect is due to mutual repulsion between ether particles compressing the particle and those of the surrounding ethers. When there has been a complete transformation of electrostatic ether bombardment into a circular magnetic flow of ether particles around the electron or proton there is never an approach close enough for attraction forces to take over.

The pinch effect also explains the behavior of permanent magnets. Consider a bar magnet. Here is an identical situation to the flow of ethers around a moving particle. The ethers flow out of one end of the magnet and into the opposite end or pole. The pinch effect that results tends to compress the opposite poles together. Two bar magnets with opposite poles adjacent to each other create the same pinch effect tending to force the magnets together, as shown in Figure 12. It is like cutting a single bar magnet in two.

When like poles are adjacent, the flow of ether particles is in opposite directions, and these poles receive more than the normal bombardment, tending to force them apart. Identical bombardment occurs regardless of whether it is the north poles or south poles facing each other. (Fig. 13,14).

The resultant force exerted on the ferromagnetic material in these two cases does seem to present a paradox. Why are such forces present yet no resultant forces are exerted on non-ferromagnetic materials? This can only be resolved by considering the individual atoms of the ferromagnetic material. The individual atoms are actually tiny solenoids. The magnetic lines or ether flow out or into each pole forms a tubular configuration. There are few if any magnetic lines existing in the central portion of the tubes as it is a vortex. This means that although most of the ether particles coming in opposite directions will be scattered and dispersed into random motions (as shown by iron filings placed over like poles facing each other) many of the magnetic lines will enter the central portion of these minute tubes. As a result there will be a greater ether bombardment on one side of the ferromagnetic atoms than on the opposite side. A so-called diamagnetic atom has an outer magnetic configuration that is relatively uniform with no pronounced poles.

The direction of motion of the particles is into the paper. The surrounding ether particles move in the same direction as the spin. This ether movement is the origin of the magnetic field.

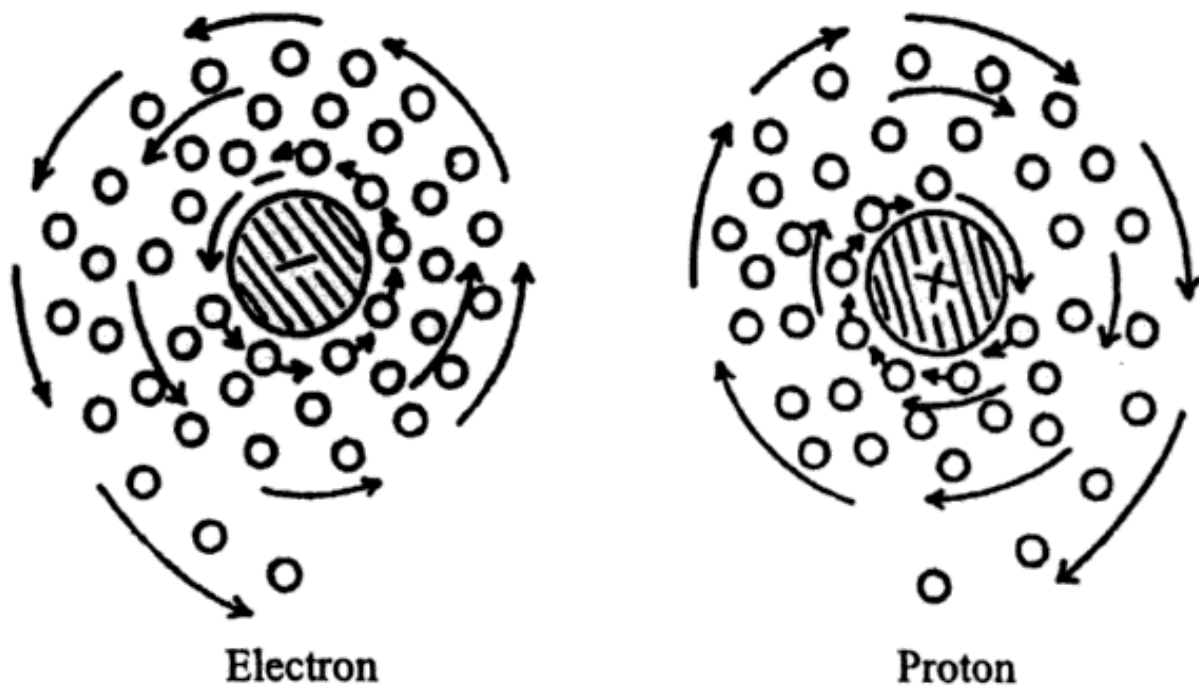

The direction of motion of the particles is into the paper.

The direction of spin is opposite to the magnetic flow on this side of the electron. This results in a lower ether pressure and a resultant force is exerted on the electron.

The direction of the force is toward the low pressure side.

The direction of flow of ether particles is from N to S

The direction of spin is opposite to the magnetic flow on this side of the proton. This results in a lower ether pressure and a resultant force is exerted on the proton

The direction of the force is toward the low pressure side.

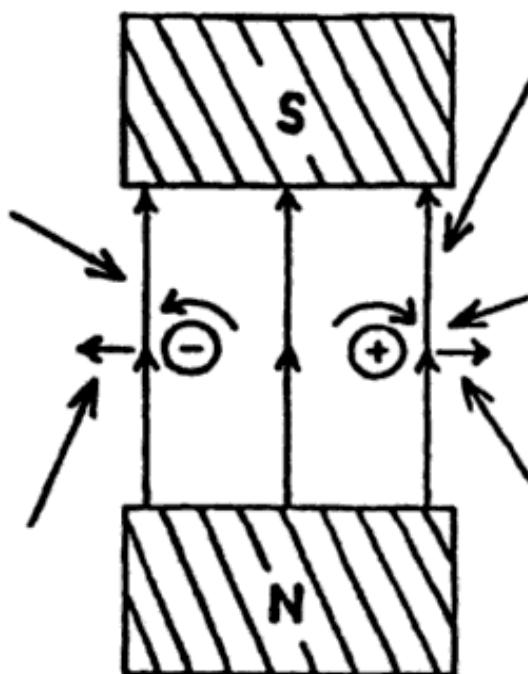

*FIG. 12: THE BEHAVIOR OF ELECTRONS AND PROTONS IN A MAGNETIC FIELD*



Consequently incoming ether particles comprising the magnetic flow are diverted from their paths before they can get past the tight magnetic shield surrounding the "diamagnetic" atoms.

It should be kept in mind that the total number of ether particles per unit volume in a magnetic field is no greater than that existing outside the field. Therefore, the ether bombardment on any one side of a diamagnetic atom is not changed when it passes in and out of a magnetic field. Thus there is a random ether bombardment on the diamagnetic atom while in the case of the ferromagnetic atom this randomness is disturbed and there is a preferred direction of ether particle movement toward the atoms.

The accepted explanation of the ferromagnetic properties of atoms such as iron fails as usual to explain any of the facts concerning their magnetic properties. The valid explanation is almost self-evident. A significant percentage of the orbital electrons have either common orbital planes or move in planes that are nearly parallel. (As will be shown later, all the orbital electrons move in the same general direction such as clockwise or counterclockwise depending on the viewpoint. This is necessary in order for the electrons to orbit the nucleus). This produces a net solenoid effect and thus the individual atoms behave like magnets. In the case of non-ferromagnetic atoms all of the orbital electrons move in different planes, none of which are parallel. This cancels out all solenoid effects. External magnetic fields cannot penetrate a material comprised of ferromagnetic atoms such as iron. The miniature solenoids are extremely mobile and readily align with an external field. This sets up a barrier which prevents the passage of the field through the material. It requires magnetic fields to affect magnetic fields. The situation is similar to that of two high speed jets of fluid. When they encounter each other the jet stream of the weaker one tends to be disrupted by any attempt to penetrate the stronger jet. The field encountered inside a ferromagnetic material by an external field is generally stronger than this field. Non-ferromagnetic, or so-called diamagnetic materials, offer only a slight resistance to the passage of external magnetic fields because only an insignificant magnetic field extends beyond the individual atoms and molecules. External fields encounter the fields of the orbital electrons but find clear pathways between the molecules. This minuscule resistance explains diamagnetism. Since the magnetic field inside a diamagnetic material is

The magnetic pattern of bar magnets is identical to that of magnetic field around a moving charge.

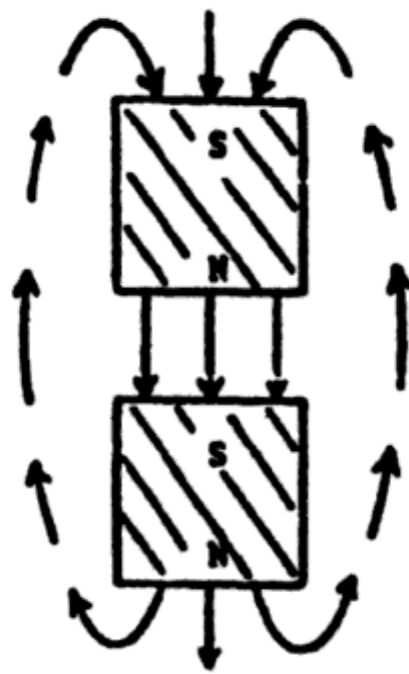

Unlike poles attract because of the pinch effect of magnetic fields.

The magnetic field around a moving particle tends to compress or pinch it as a result of pressures exerted by surrounding ethers. This is the result of Bernoulli's principle.

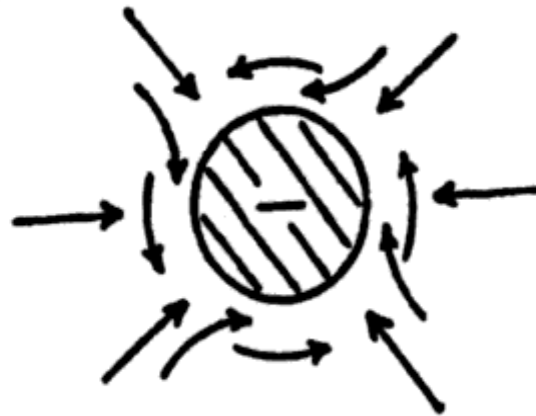

The surrounding ethers tend to move in toward low pressure areas initially created by the spin.

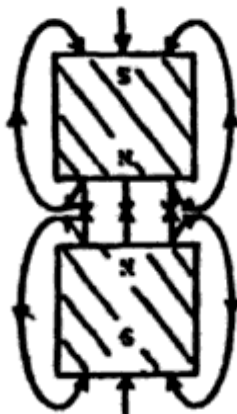

Like poles repel because of excessive ether bombardments against the material of the magnets

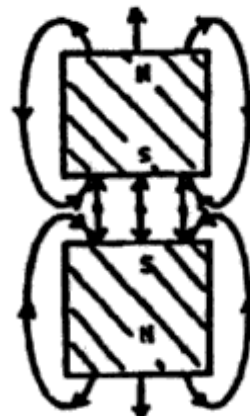
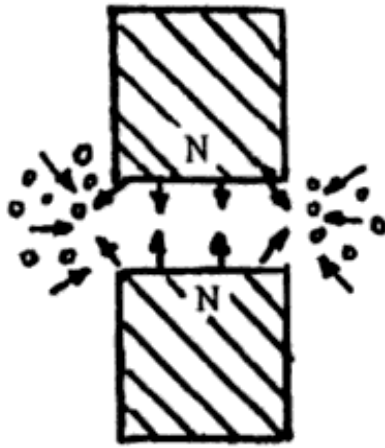
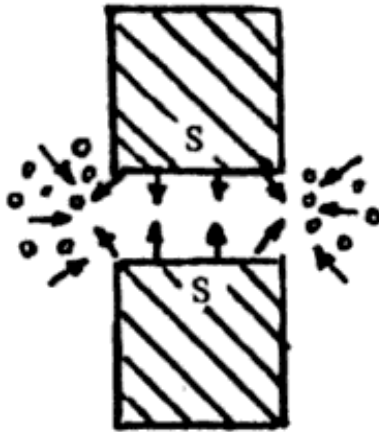

FIG. 13: THE PRINCIPLE OF MAGNETS



Two like poles in which the ether flow is outward produce a repulsion because of excessive ether bombardment into the magnets. This is helped along by the Coanda effect. The ether flow out of the magnets tends to create voids and the surrounding ethers move in to fill the voids. This results in higher concentrations of ether particles between the magnets and thus greater ether bombardment at this portion of the magnets.



When two like poles with the lines flowing in are adjacent, the Coanda effect becomes more pronounced, resulting in a greater flow of surrounding ethers to fill the voids. This produces the same excessive ether bombardments on the magnet as when two north poles are adjacent. The concentration of ether particles between the magnet is the same in each case.

*FIG. 14: REPULSION OF TWO LIKE POLES OF A MAGNET*

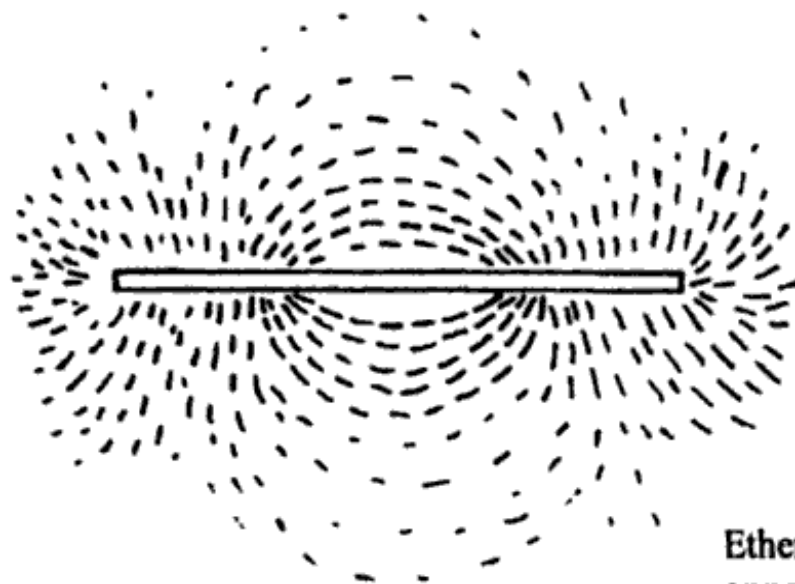

At nodal points ether particles enter and leave the surface of the magnet

Ether flow into opposite pole to fill void produced by alignment of atomic solenoids

*FIG. 15: THE PATTERN OF IRON FILINGS AROUND A MAGNET SHOWING NODAL POINTS AND FLOW OF ETHER PARTICLES*

slightly less intense than that of the external field, all materials other than ferromagnetic, display this characteristic. According to the accepted explanation, atoms of diamagnetic materials align themselves in a direction opposite to that of the external field. This is a very peculiar property since it violates all the rules of magnetic phenomena. This type of explanation is another example of the bad habit physicists have of using a manufactured, inexplicable mystery to resolve a lesser one, and, thereby, have created a greater mystery than existed before.

The analogy of fluid mechanics as applied to magnetic fields can also be employed to explain the properties of bar magnets. When iron filings are used to show the configuration of magnetic lines around a bar magnet it becomes evident there is a direct flow of ether particles out of one pole and into the other pole. The configuration is the same regardless of whether the lines are flowing in or out. When the magnet is very short the flow out of one pole creates a direct void behind it, resulting in a flow to the opposite pole. As the magnet becomes longer a new dipole begins to develop between the two opposite poles. This effect is enhanced by an ether flow toward

the sides of the magnet from the surrounding ethers as a result of a sink produced inside the magnet. When the magnet becomes longer, a complete dipole is produced inside the magnet between the opposite poles of the magnet. Since the flow is somewhat restricted, the direction of the ether flow follows an oval-like pattern. This dipole, of course, provides a sink for an ether flow into the opposite pole. Thus an illusion is created of a flow into one end of a bar magnet and out the other end. See Figure 15. It is significant that this ether flow into one pole is not the same flow as that which came out of the opposite pole!

Since the ether flow out of the poles has no opposition from the flows out of the inner portions of the magnet they will extend for greater distances beyond the magnet than the lines between the poles. Since the ether flow inside the magnet between the poles tends to follow oval patterns, nodal points will form along its length by the ethers flowing out of the one segment into another further down the magnet. There will be an even number of nodes. For example, a magnet of moderate length will have two nodal points. If the length becomes much greater, four nodal points will appear, etc. This property of magnets will be employed later to explain the six belts of prevailing winds that exist between the magnetic poles of the Earth.

The magnetic permeability of ferromagnetic materials is always greater than unity, while the permeability of diamagnetic materials is always less than unity. Magnetic permeability of a substance is defined as the ratio between the magnetic flux within a material and that of the external field to which the material is exposed. Since the atoms of a so-called diamagnetic material have no fields of their own to be aligned when exposed to an external field, the resultant field inside the material will have a lower intensity than that of the external field. This is because the individual atoms disrupt some of the magnetic lines that penetrate the material. Ferromagnetic atoms align themselves with the external field. This results in a much higher magnetic intensity within the material.

Some experimenters have allegedly demonstrated that non-magnetic metals, such as aluminum, can be converted into powerful permanent magnets by bombardment of certain kinds of energy. The permanency of the magnetic properties imparted to these metals depend on the length of time exposed. The induced magnetism was only temporary when the exposure time was brief. However, after a



long exposure, the metals become permanently magnetized. This provides a clue as to what has transpired. The soft particles bombarding the material have carried hard electrons with them, thus permeating the material. The soft electrons, being able to penetrate the atoms, enable the hard electrons enclosed within the soft particles to enter the atoms and assume orbit. These additional electrons create the solenoid effect.

It is evident that the properties of these magnetic fields and the pinch effect they produce are the greatest factors in maintaining stability in the atom. The motion of the electrons in all directions produce low pressure effects causing the ethers to move in from all directions. This confines the electron movements to very restricted areas with overwhelming forces.

The concept of thousands of electrons comprising the atom and the omnipresence of camouflaged, hard electrons, resolves many questions concerning atomic structure, which cannot be properly understood on the basis of the idea of equal numbers of electrons and protons. Many physicists have toyed with the idea of an electron occupying many different places simultaneously, in order to make the facts conform with the accepted picture of the atom. An electron was looked upon as a cloud surrounding the nucleus. This concept, of course, was not compatible with the results of cloud chamber experiments. Once again, the ability to doublethink enabled them to live with the dilemma.

With this newly established viewpoint, the differences between a chemical bond and a cohesive bond, as well as the reason that a chemical bond is many times more powerful than the cohesive bond, becomes clear. Cohesion exists when the outer electron shell of atoms and molecules are separated but are close enough so that the zonal effects become effective. In other words, the attractive forces are stronger than the repulsion forces. A chemical bond occurs when atoms are forced together close enough so that outer electrons are brushed aside by mutual repulsions, and the nuclei of adjacent atoms are separated by a relatively thin cloud of electrons. In this manner, atoms are bound together by the mutual attraction that their nuclei have for the same layer of electrons. This could not occur with the relatively few electrons previously attributed to atoms by orthodox science. Such a close proximity of nuclei is more likely to occur with dissimilar atoms. Under the right conditions, a similar pattern can be produced with atoms of the same element. This results in the

allotropic forms of an element, such as carbon atoms, combining to form a diamond. It is interesting to note that diamonds are created only under conditions of extreme temperatures and pressure, conducive to forcing the atoms into more intimate contact with one another. The excessive heat and pressure tend to drive off many of the outer electrons. This gives the atom a higher net positive charge. As a result, the atoms are not only able to come closer together, but they have a higher specific gravity than carbon in the amorphous form.

The ionization process tends to break the chemical bond as well as other processes, such as electrolysis, and the concept of valences, which will be analyzed later.

## **THE CAUSE OF GEOMAGNETISM**

The conventional theory of geomagnetism has about the same merit as some other theories already discussed. According to the accepted viewpoint, the major portion of geomagnetism is the result of electric currents in a molten iron core 2,000 miles below the surface. The theory is automatically destroyed, because an iron core doesn't exist. But even if one did exist, the conventional conclusion would be equally false. Scientists are somewhat vague as to how a magnetic field could extend 2,000 miles beyond an electric current. It requires a very powerful current to produce even relatively weak magnetic effects a very short distance above the flow. The electrical resistance of iron, at the alleged temperatures of the core, would be staggering. A steady flow of electricity requires constant potential differences. How are such potential differences produced and maintained in this hypothetical core?

The magnitude, width, and depth of such currents would have to be unbelievable to extend the magnetic field even a small fraction of the distance required, and the EMF required to produce it would be even more incredible. Where could such an EMF come from? So far, scientists seem reluctant to explain this, especially since these currents are confined to a ball and would therefore follow closed paths.

Another incredible demonstration of inconsistencies and contradictions in conventional physicists' thought processes is the case of Saturn and its magnetic field. For them, an iron core is essential for explaining a significant magnetic field around a planet. According to

astronomical data, Saturn is supposed to have a very low mass in proportion to its size. Yet all the evidence, including probes sent to its outer atmosphere, shows it has a powerful magnetic field. To account for its relatively low mass, physicists conclude the core must consist of liquid hydrogen. Evidently, the art of doublethink has come to the rescue again. The threat of this speculation to geomagnetic theory has apparently been ignored.

A great wealth of evidence supports the conclusion that geomagnetism is produced by the Earth's rotation. The intensity of the field is dependent on the concentration of negative charges in the atmosphere and the crust, and also the rotational velocity. As the Earth rotates, it carries the charges along with it. This is equivalent to a myriad of electrical currents, all moving in the same direction. This effect is identical to that of a great solenoid. Interestingly enough, the polarity of the Earth's field corresponds to that of a solenoid with a current flowing in the direction of the Earth's rotation. The charges in the atmosphere and crust are predominantly soft electrons. Soft electrons, without the specialized shape of hard electrons, have no preferred direction of spin. However, hard electrons are continually being released by the soft particles, particularly at the magnetic poles where the giant egresses from the Earth's interior are located. The hard electrons set the pattern of spin for all the other particles moving with the earth's rotation.

Physicists have always assumed that a magnetic field is apparent only when a charge is moving relative to the observer. This is very bad reasoning. It actually violates the laws of electromagnetic induction. It is a well known fact that a conductor that moves perpendicular to the magnetic lines produced by a permanent magnet or a solenoid will have an EMF induced in it. The EMF is directly proportional to the velocity. Assume a conductor is moved in the same direction as that of electrons flowing in a solenoid and that the velocity is the same as the velocity of the electrons. It will cut the magnetic lines produced by the flow of electrons in the solenoid and, therefore, have an induced EMF. According to the previously stated reasoning of the physicists, the conductor has no motion relative to the electrons, therefore, is not aware of any magnetic field. This means it could have no EMF induced into it.

Since the direction of the field is perpendicular to the direction of motion of the charges which produce it, the field will be evident even if the observer is moving with the current without relative mo-

tion, as is the case at the Earth's surface. Perhaps this oversight by the physicists is one of the main reasons the obvious cause of geomagnetism has escaped them.

Since the concentration of charges in the atmosphere fluctuates according to a 24-hour cycle, the magnetic field can be expected to fluctuate accordingly. This is an established fact. The field should increase during sunspot activity when the Earth receives more charges. This is another fact. The moon, with a small fraction of the earth's rotational velocity and receiving the same bombardment of charges from the sun, should have a correspondingly small percentage of the earth's field. The Apollo missions to the Moon and Moon probes have verified this. Jupiter and Saturn with their high rotational velocities should have fields much stronger than on Earth, despite being further from the Sun. NASA probes have detected fields in the upper atmospheres about eight times as great as at the Earth's surface. Every available bit of evidence supports the above viewpoint concerning geomagnetism.

An enigma that may arise is that the Earth has an orbital motion in addition to its rotation. Why doesn't the orbital velocity affect the Earth's field? The Earth's apparent field is produced by the hard electrons, released by the soft electrons as they approach the Earth and enter the atmosphere. During their trip to the Earth, the captured hard electrons are in a dematerialized state, therefore, have not acquired any kinetic energy by the time they reach the Earth, since they are in this state they have no inertia. After they are released, they are accelerated to the Earth's rotational velocity. Therefore, the only kinetic energy they display is that which is due to the rotational velocity of the Earth. It is the collision of soft electrons bombarding the molecules of the atmosphere and particles contained in the atmosphere that cause some of the soft electrons to release the hard electrons responsible for the Earth's magnetic field. The hard electrons are continually being released and recaptured again by soft electrons. Consequently, there are always hard electrons present in the atmosphere.

Obviously there is a lot more to the Earth's magnetic field than that produced by the motion of hard electrons. There are magnetic fields produced by the soft electrons permeating the atmosphere and are not detected by standard magnetometers.

An experiment that confirms the validity of what has been introduced concerning the nature of magnetic fields and gravity which

will be discussed in the next chapter involves the rates at which a strong magnet and another body of equal weight falls. It has been found that the body of equal weight falls faster than the magnet. In view of what has already been revealed the reason once again becomes almost self-evident. The magnetic field captures a high concentration of soft electrons which impregnate the magnetic material. This tends to reduce the weight of the magnet because gravity repels negative charges. This means that in order for the magnet to weight the same as the body it must have greater mass. Therefore, it boils down to the same accelerating force having to accelerate a greater mass than with the unmagnetized body. It follows that a magnetic material will weigh more before it is magnetized than it will after it is magnetized.



## CHAPTER 12

# THE NATURE OF GRAVITY AND RELATED PHENOMENA INCLUDING LEVITATION, MISSILE WEIGHT LOST IN SPACE, AND FASTER THAN LIGHT SPACESHIP PROPULSION

### THE NATURE OF GRAVITY

The prerequisite for understanding the gravitational process is the realization that supposedly uncharged atoms and molecules are not electrically neutral, but possess a positive charge. It has always been assumed, since the days of Newton, that inertia is directly proportional to mass. This has been shown to be incorrect. Inertia is dependent upon total charge; therefore, independent of mass. It follows that an atom has less inertia than any of the fundamental particles from which it is comprised! The small, overall charge of an atom is the result of the equalizing of positive and negative charges. Its slight ability to generate a magnetic field for a unit increase of velocity is due to electrons following the left-hand rule, while protons follow the right-hand rule. Its inertia is limited because of the cancellation of the magnetic fields of the constituent electrons and protons.

Practically all of the net positive charge field effects of a body are inside because of the minute positive field extension around each atom. This is because the field intensity does not follow the inverse square law due to cancellation effects of the plus and minus field effects. The plus charge effect drops off much more rapidly than if it followed the inverse square law. The field intensity within this small zone is very high.

Stripping electrons from an atom will give it a strong positive charge. This means it will have greater inertia than before, although less mass. Adding electrons will also increase its inertial properties,

if the total resultant charge is greater than the original positive charge. Otherwise, adding electrons will reduce the inertial properties, and, in this case, increasing the total mass would reduce its inertia.

After the author came to this conclusion, he was later gratified to learn that a former Nobel Prize winner, Gabriel Lippman, confirmed this principle in the late Nineteenth Century. Lippman found that bodies in the charged state offered a greater resistance to acceleration than in the uncharged state. He calls it "The inertia of static electricity". It is not surprising this monumental discovery was ignored, since it threatened to topple cherished physical concepts. Ironically, Lippmann later received the Nobel Prize for another comparatively insignificant discovery.

Sufficient groundwork has now been laid for a complete understanding of the nature and cause of gravitational effects. Gravity has always been the most baffling of all the common physical phenomena. Until now, no theorist has ever come close to presenting a theory in any way plausible, or which fits the facts. It will soon become evident that nearly all of the basic concepts introduced thus far are required in order to properly explain it properly.

It has already been shown that gravitational effects are produced by a part of the electromagnetic spectrum, somewhere between the lower portion of the infrared and the radar frequencies. This knowledge is still insufficient to give one some insight into the mechanics of the forces involved. Since matter behaves like a positive charge, it follows that gravity radiations accelerate positive charges in a direction opposite to that of the direction of its propagation.

It has been stated that a gravitational field repels negative charges. This has been shown to be the case. The RCA laboratories in Princeton, New Jersey, allegedly demonstrated this in 1959. They supposedly discovered that negative charges tend to fall upward instead of downward, as had been expected. It is readily apparent why nothing more has been heard about it.

Some of Reichenbach's experiments, to be discussed in Part IV, also indicate that such is the case. This effect was predicted on purely theoretical grounds by the author prior to the knowledge of these confirmations. A well-known phenomenon also demonstrates the fact that negative charges are repelled by a gravitational field. When the hair on one's head is given a strong negative charge it will have a tendency to stand straight up. This becomes especially pro-

nounced if one stands near a powerful Van de Graff generator when it is throwing out high concentrations of electrons. Many of the electrons become attached to the hair and tend to carry the hair with them as they are repelled upward. This simple fact alone is sufficient to invalidate all of the current theories of conventional theoretical physics.

This knowledge still leaves unanswered questions such as: "Why are the gravity-inducing radiations in this frequency range? How do they produce attractions and repulsions on positive and negative charges?" One important principle should be kept in mind before dealing with the mechanics of gravity. The more a given radiation, and the ethers with which it is associated, differ in frequency from other radiations and the matter and the ethers with which this radiation is associated, as well as the soft particles that permeate matter, the less it will be interfered with in its passage through matter. In other words, the more penetrating it will be.

The bulk of the radiations and soft particles of matter cover only a relatively narrow part of the electromagnetic spectrum. (Figure 16). They are produced by the interactions of the fundamental particles of the atom, in addition to the interactions of the atoms themselves. This range extends from the upper end of the infrared to the lower end of the ultraviolet. Most of the remaining frequencies are in the higher ranges and are radiated by Sun like bodies or created artificially in laboratories. Many of the particles resulting from higher-frequency radiations are absorbed by matter. It can be concluded from the principle mentioned above that infrared will be the most penetrating of the radiations mentioned.

Since infrared is at the lower end of the scale, the soft electrons associated with infrared will be less stable than harder electrons. This means the infrared will be more inclined to give up the harder electrons it contains when it penetrates matter. This and its penetrating ability are the reasons infrared is more heat producing than other radiations. It follows that the radiation's penetrating ability will increase as the lower range of the infrared is approached. Finally, the most penetrating radiation of all can be expected just below the lower infrared. Its frequency range and the ethers with which it is associated are further removed from the ethers associated with the particles of matter and the particles that interpenetrate matter, than that of any other radiation produced by physical matter. These are

the gravity-inducing radiations. They encounter the least resistance in passing through these concentrations of particles.

At this point, a question that no doubt comes to mind is, "Why aren't the radar frequencies penetrating?" They seem to be in a range which should make this possible. Since radar bounces off matter, it shows that it encounters concentrations of soft particles consisting of photons somewhere in the approximate range. Along with the frequencies produced by the normal activities of atoms and molecules, harmonics and beat frequencies also exist. These comprise only a small part of the energy produced by such reactions, but it results in the release of soft particles comprised of photons in the lower frequency ranges, which interpenetrate matter at all times. This is the reason radar and still lower-frequency radiations in the radio band have a limited penetrating ability. Incidentally, it is the soft particles comprised of photons close to and in the visible range which permeates matter, and thereby renders matter visible. If only the hard particles were present, solid matter would be invisible, although completely tangible.

Now that the frequency range of the gravity radiations has been logically established, the next step is an analysis of the mechanics of gravitation. Basically, the nature of gravity radiations is the same as that of other radiations, with the exception that they are the most penetrating. They consist of photons and soft particles comprised of such photons, which accompany the photons. The photons travel at a higher velocity than the accompanying soft particles, as in the case of other radiations. It is apparent that the leading portion of the gravity radiation front produces negative charge effects, while the trailing portion which has passed a given body must have substantially reduced negative-charge effects. If this were not true, there would be no gravity effects. From the superficial standpoint, it would seem that an impasse has been reached. The negative charge of the leading portion of the "wave" front produces the necessary effects, and the rear portion should have the same effects, which would result in a cancellation, and therefore no gravity result. This means that in order for gravity to manifest itself, the trailing portion of the soft particle wave must either have little or no electrostatic field effects, or a positive field. There are two factors which make

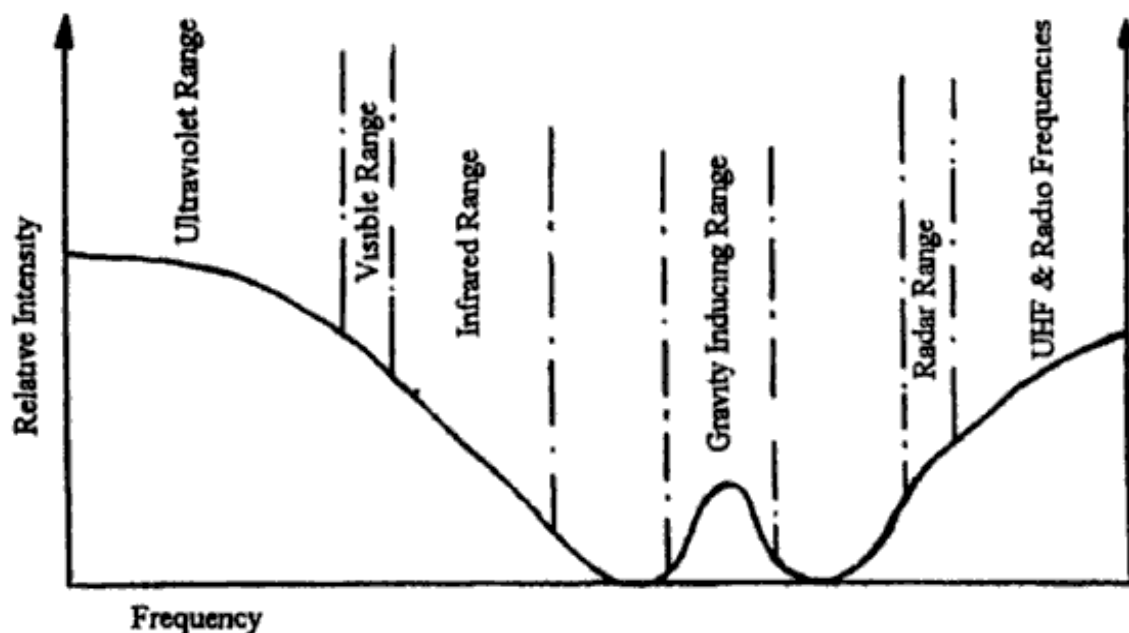

Curve represents intensities of photons and soft electrons corresponding to various frequencies which permeate matter. (Relative intensities and frequencies not in correct proportions).

**FIG. 16: THE REASONS GRAVITY INDUCING RADIATIONS ARE HIGHLY PENETRATING WITH LITTLE TENDENCY FOR ITS PHOTONS AND SOFT ELECTRONS TO BE SCATTERED DURING PAS SAGE THROUGH MATTER**

*It has been mentioned, the greater the difference in frequency between different radiations the less the tendency for them to interfere or interact with each other. From this graph it is evident the gravity radiations are unique. Their frequency differ widely from any of those associated with the soft electrons and photons that permeate matter. Consequently they are the most penetrating of any other radiation and pass through matter with minuscule scattering. It is also apparent why infrared is more penetrating than visible or ultraviolet light.*



this possible: first, it is the spin of the particles which produce gyroscopic effect, and keeps the particles oriented in the same position. Second, the photons of this radiation have little tendency to scatter.

The cause of gravity effects is now becoming apparent. The faster moving photons overtake the soft particles, and tend to adhere to them in irregular patterns as they collide. This creates a perforated and extremely rough surface on this portion of the particle, not unlike that of a positive charge. This has a tendency to cancel out much of the negative field effects on this portion of the particle. The bombardments accelerate the particles to such an extent that no more photons can adhere to them. Therefore, the rear portion maintains the positive charge, or at least a badly impaired or reduced negative charge. Figures 17 and 18 illustrates this principle.

Another important factor which contributes to a reduced negative charge effect at the rear, is that there is a far greater photon concentration in this region than exists at the frontal portion. This is a result of a backup of photons, resulting from the lower velocity of the soft particles accompanying the radiation. This photon concentration, tends to divert the normal ether bombardments, producing the electrostatic effects, from their usual paths.

Now it becomes apparent that gravity effects are consistent with the picture presented earlier on the structure and differences of positive and negative charges. The reason for the limited penetrating ability of gravity effects, also becomes evident. Since gravity radiations produce forces, it follows that there are interactions, which eventually disperse the radiation. This is in accordance with the law of conservation of energy.

The intensity of the electrostatic field produced by the gravity radiations is extremely minute due to the fact that they are highly penetrating and produce slight interactions. The following analysis will give the reader some idea of the magnitude of this field. An electrostatic field of even modest intensity can give an electron sufficient acceleration so that in the distance of about a foot, as in a cathode ray tube, it is traveling 15,000 miles/sec or  $2.5 \times 10^7$  cm/sec. Earth gravity could accelerate the same particle over the same distance to a velocity of about 8 feet/sec or about 250 cm/sec. The acceleration necessary to give a particle a velocity of  $2.5 \times 10^9$  cm/sec is about  $10^{17}$  cm/sec<sup>2</sup>. This means that the accelerating force, or intensity, of even a moderate electrostatic field is approximately  $10^{14}$  or 100 trillion times as great as the Earth's gravitational field!

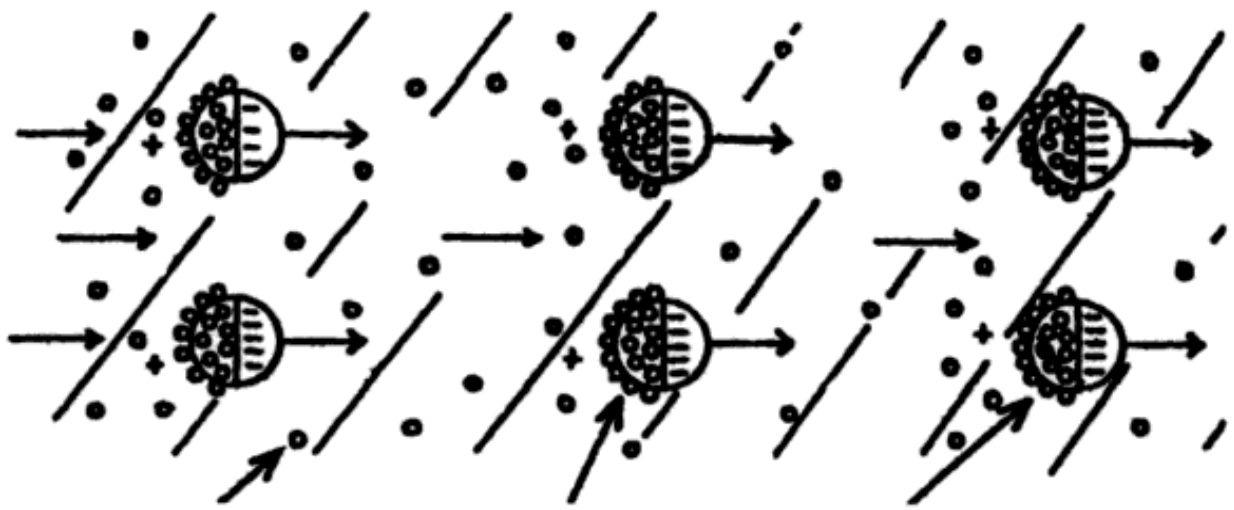

Photons of gravity-inducing radiations not appreciably scattered while passing through positive matter

Soft electrons comprised of gravity-inducing radiations

Photons of gravity-inducing radiations collide and attach themselves to the back portion of soft particles comprised of gravity-inducing radiations. This in part tends to nullify the negative charge effect on the back side of the soft electrons.

**FIG. 17: GRAVITY-INDUCING RADIATIONS**

*Clusters of photons regularly spaced to produce a ray of photons. This is typical of all electromagnetic radiations of all frequencies and indicates that light consists of longitudinal or compression waves similar to that of sound instead of transverse waves. Soft electrons, accompanying the radiation, travel at a lower velocity than the photons and their distribution does not follow a definite wave pattern.*

Higher photon concentration in this region because photons are moving toward soft electrons.

Lower photon concentration in this area because photons are moving away from soft electrons.

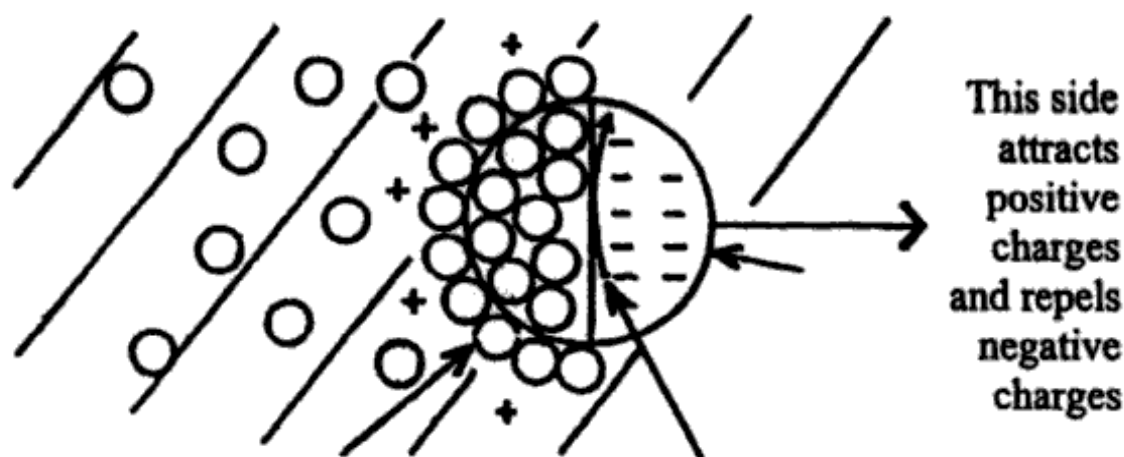

The spin of the soft electrons produces a gyroscopic action which enables the particles to maintain its charge orientation with respect to the direction of propagation.

**FIG. 18: ENLARGED SOFT ELECTRON  
COMPRISED OF GRAVITY RADIATIONS**

*The high photon concentration on one side of the soft electron tends to divert ether bombardments from paths which produce electrostatic effects. This tends to neutralize the negative charge effect on this portion of soft electron. As a result a net negative charge effect is produced in the direction of propagation which causes positive charges and matter to be given an attraction in a direction opposite to the direction of propagation and negative charges a repulsion in the same direction of propagation. This pattern is typical with all frequencies. The only difference between gravity-inducing frequencies and other frequencies is that the soft electrons of the gravity radiations are not scattered to the extend of others in different frequency ranges.*

Three major reasons exist for this incredible disparity between electrostatic and gravitational accelerations: First, the gravitational radiation affecting matter comprised of soft particles is associated with the lower ethers. Therefore, soft particles in this range can interact with the overall positive charge of matter to only an infinitesimal extent. The other reason is that of the low field intensity around soft particles. It was shown earlier that the field intensity around a photon or a particle is directly proportional to the frequency. This means that the field intensity is only about  $1/10^8$  or that of a hard electron since a gamma ray has about  $10^8$  or 100 million times the frequency of the gravity frequencies. This relative field intensity disregards the slight additional effects produced by the harder particles camouflaged by the gravity-inducing soft particles. The combined effects of the soft electrons and camouflaged hard electrons produce the field intensity around the gravity-inducing soft particle. These factors, combined with the very low net positive charge of atoms and molecules, result in the relatively minute acceleration gravity radiations imparted to ordinary matter.

A question which might arise at this stage is, "Why doesn't light passing through a transparent substance produce a gravity effect on it?" Light photons are quickly scattered and dispersed, even when passing through transparent substances. It is the soft electrons, continually disintegrating into light inside these transparent substances, that enable visible light to penetrate considerable thicknesses of transparent materials. When soft particles disintegrate, new photons are released. Even the most transparent substances soon disperse visible light completely. It is the complete scattering of photons, the disintegration of particles, and their scattering in all directions that render all radiations, except the gravity radiations, incapable of producing gravity effects!

It is not difficult to see how these concepts destroy the popular theory of Black Holes mentioned in Chapter 2 on Relativity. Incidentally the frequency range of the gravity inducing radiations corresponds to wave lengths between .3 and 4.3 millimeters.

## **THE PHENOMENON OF LEVITATION**

It is now apparent that gravity is an electrostatic effect, not some space warp or mysterious force with imponderable properties de-

picted by orthodox physicists. It follows that if matter is impregnated with sufficient quantities of negative charges, especially soft electrons, it will become weightless and even levitate. Some "adepts" in the occult arts have demonstrated this ability on occasion. In spite of this, and the experimental evidence showing that negative charges are repelled by a gravitational field, conventional theorists continue to ignore it, and assume that gravity reacts indiscriminately on all things alike. Once again, this is to be expected. If orthodox scientists recognized the reality of such things, they would automatically have to abandon nearby all the concepts they hold dear.

Some individuals seem to have the ability to do the reverse of levitation and impregnate their bodies with an abnormal positive charge by perhaps expelling large quantities of negative charges from their bodies. They make themselves inordinately heavy by this means. A certain dwarf who had a normal weight of 123 pounds could increase his weight to 900 pounds. He demonstrated this ability on television programs under rigorous fraud-controlled conditions. In fact, one famous strong man who lifted him up was unable to hold him, when he decided to increase his weight to 900 pounds. During this perilous turn of events, our scientists once again showed admirable composure and resourcefulness. They remained silent.

## **MISSILE WEIGHT LOSS IN SPACE EXPLAINED**

The physics of levitation was demonstrated in part when missiles were found to have lost most of their original weight after traveling through the Van Allen Radiation Belt and returning to Earth. The mystery deepened when this weight loss continued for a time, and containers in which pieces of the missile were placed also lost weight. This event was hushed up in keeping with standard policy concerning things which are damaging to orthodox concepts. The radiation belt contains high concentrations of negative charges of all kinds, from hard electrons to the very soft ones.

The missile became impregnated with negative charges as it passed through this region. Since they are of varying types, it was able to absorb an abnormal quantity. The more penetrating softer particles opened the door for the harder particles to enter. A similar principle is involved in the operation of a transformer and will be



discussed later in Part III. Because the missile continued to lose weight, and was evidently losing particles that originally caused it to lose weight, a paradox arises. The loss of weight of the container, in which pieces of the missile were placed, which would mean that the pieces were discharging some of the negative charges they had picked up in the radiation belt, and were then absorbed by the container.

Paradoxes are actually a blessing, instead of being an annoyance to be kicked under the rug, as scientists have the bad habit of doing. They enable one to gain a better insight, if the brain is up to it. The first part of the above enigma is taken in stride. The absorption of the negative charges reduced the overall positive charge of the missile, and thereby reduced the gravitational attraction. Only one other conclusion can be derived from the subsequent phenomena. The number of negative particles expelled by the mass was small compared to the number of orbital electrons in the body. After it was impregnated with the conglomerate of particles, a readjustment of activity in the original particles began to take place. This had to continue until a new state of equilibrium within the atoms was reached. Although soft particles were being ejected continuously, those left behind were constantly disintegrating and depositing hard electrons within the atoms of the material. They, of course, assumed orbit around the nuclei of the atoms. The additional electrons captured by the atoms reduced the overall positive charge and, consequently, the weight, despite the particles being ejected. This process was actually producing allotropic forms of the elements comprising the material. This phenomenon is confirmation that there are thousands of electrons to every proton in the atom. Such a process could not occur on the basis of the conventional picture of the atom.

## **MISSILE WEIGHT LOSS IN SPACE POINTS THE WAY FOR DEVELOPMENT OF NEW MATERIALS OF EXTREME LIGHTNESS AND STRENGTH**

Missile weight loss shows that a practical method of producing materials of unprecedented lightness and strength is entirely possi-

ble. A reproduction or simulation of the Van Allen radiations on the Earth would demonstrate this. Evidently, the type of electrons required are combinations of such particles that are comprised of photons from gamma rays down to lower frequencies, but still far above those of ultraviolet. Softer particles comprised of X-ray photons and slightly above would readily penetrate matter and carry still harder particles with them into the atom. The tensile strength of cohesion between atoms and molecules could be increased with the right combination of particles locked between the molecules. They would have to differ slightly in degrees of hardness in a progressive manner so there is an interlocking and interpenetration. A method of generating large quantities of soft particles of any frequency will be presented later on in Part III.

## **THE POSSIBILITY OF FASTER THAN LIGHT SPACESHIPS BY MEANS OF GRAVITY- INDUCING RADIATIONS**

In Part I, it was shown that gravity-inducing radiations can be used as a highly sophisticated means of propulsion. In addition, such an application would account for the amazing performances of UFOs. It will be shown that this means of propulsion can produce almost unlimited velocities. The conditions of spaceships are different from those imposed on particles inside an accelerator since in this case the accelerating force travels with the mass being accelerated. There is also the consideration that atoms are accelerating instead of fundamental particles, which have a much lower velocity potential than atoms.

It was shown earlier that fundamental particles have far greater inertial properties than the atom. Therefore, when an atom is accelerated to a given velocity, a much lower quantity of electrostatic energy has been transformed than in the case of an electron or proton accelerated to the same velocity. The alleged reports about space visitors claiming that some of their ships can travel thousands of times the speed of light has a valid scientific foundation. By applying the gravity beam type of propulsion, a spaceship can easily exceed the speed of light with little change in its physical structure. At

ultra-high velocities, or at a state where most of the electrostatic potential of matter has been transformed, cohesive forces will tend to break down and the material will become fluidic. It may be interesting to note that the late Gloria Lee, in her book entitled *Why We Are Here*, quoted one of the space beings as describing identically this phenomenon, when spaceships travel at velocities equal to hundreds or thousands of times that of light.

The velocity potential of a spaceship could be greatly increased by impregnating the ship and all the occupants with the right combination of negative charges. This could be carried to such an extent that the overall charge could be almost completely eliminated. The inertial properties would be greatly lessened and much higher velocities could be attained without transforming much of the electrostatic mass into magnetic energy.

When a body is traveling at such speeds, why don't ether particles attach themselves to the body in ever increasing numbers? How do they manage to escape? It is the very sudden changes in velocity which cause the particles to jam close enough together to combine with each other or anything else. As long as the acceleration is below a critical value, a mass of ether particles tends to form ahead of the moving object, closer together than normal, but not close enough to generate attractive forces. This mass affects other ethers in the path further ahead, but in lesser degrees. The result is that other ethers are moved out of the way. As the velocity increases, the region of affected ethers increases in extent.

At ultrahigh velocities, the closing forces on the rear no longer compensate for the forward resistance, so it requires a steady application of accelerating forces to maintain velocities many times that of light. This is probably the reason aliens have allegedly stated that some of their ships are much faster than others.

There are a number of reasons why a body traveling in free space at a steady velocity will encounter practically zero resistance. It has already been shown that ether particles of differing frequencies have little tendency to interact. This means the only ethers that could offer resistance to a body moving at a steady velocity are those associated with the fundamental particles of which the body is comprised. Such ethers are relatively rarefied compared to solid matter and light. When this is coupled with an ultrahigh concentration of such ethers in a single body, a situation arises analogous to an extremely

dense and massive body passing through an almost non-existent atmosphere.

The tendency for the ethers to offer resistance to the passage of a body is reduced to the vanishing point by the extreme activity of the ether particles, whose average velocity is many times that of light. As a result, the trailing part of the body is bombarded by ether particles almost to the same extent as the leading portion. This is accentuated by the Coanda effect. The rear portion tends to create a void as it passes through the ether. The rush of ether particles to fill the void produces a bombardment that offsets the frontal resistance. This means that a resultant force of near zero is exerted on a body traveling at a steady velocity.

The evidence concerning spaceship propulsion demonstrates that the famous Einsteinian equation  $E = mc^2$  falls far short of representing the energy potential of matter. From the kinetic energy equation  $E = \frac{1}{2} mv^2$  it follows that a body traveling only one and one-half times the speed of light, which isn't even a cruising speed for most spaceships, has a kinetic energy exceeding the value indicated by this celebrated equation. At this velocity, only a minuscule part of the energy potential of the mass has been released. The meaninglessness of the famous relation is also evident, because inertia is dependent only on net charge and not necessarily on mass or quantity of material. The mass factor in the equation is based only on quantity of material, with the ordinary uncharged atom as a standard.

## **FLUCTUATIONS OF THE GRAVITATION CONSTANT G**

The author has recently uncovered another item which demonstrates the validity of concepts introduced in this chapter and elsewhere in this book. It is the fact that determinations of the so-called gravitation "Constant" G, is always significantly higher when measured in mines, than those made in surface laboratories. From what has already been shown, this is to be expected. The soft electron concentration below the surface of the ground, is much higher than that above the surface,

for reasons already elaborated upon, therefore, the gravitating bodies used in the experiments will be impregnated with a higher concentration of soft electrons in mines, than they would on the surface. This means they will radiate a higher concentration of soft electrons, and thus a higher concentration of gravity-inducing soft electrons. This effect is enhanced by the fact that soft electrons at these levels will also contain a higher percentage of gravity-inducing soft electrons by the redistribution law. The overall positive charge of the masses is not affected, because these soft electrons are not locked within the atoms. Otherwise, they would not escape so readily. It is not surprising that the scientific community has been very quiet concerning these developments.

Another fact disturbing to physicists and consequently given little publicity, is that objects at the bottom of deep mine shafts, weigh significantly less than they should, according to the Newtonian concept of gravity. This is just another of the many confirmations of the validity of concepts introduced in Chapter 6.

In addition to this disturbing fact is another enigma which is damaging to the academic viewpoint. Experiments indicate that gravity doesn't impart the same acceleration to all substances. The physicists' attempt to explain away these two anomalies are entirely predictable. To complicate still more is the grotesque picture they have painted, they postulate a mysterious 5th force to be added to the four that already adorn their world system, which includes gravity, electromagnetism, and the weak and strong forces within the atom. This 5th force is supposed to be an extremely feeble repulsive force with a limited range. It is supposedly more prevalent in some substances than in others. At the bottom of mine shafts, strata is encountered which radiates more of this weak, repulsive force. The obvious explanation involving the limited penetration of gravity effects escaped them.

The slight differences in the acceleration gravity gives to different substances is consistent with concepts already introduced and is to be expected. Different atoms and molecules have different total positive charge effects in proportion to the number of fundamental particles comprising same. Consequently they will not be given the same acceleration. Equal weights of two different substances simply means that the one comprised of atoms and molecules with a lower net charge will contain more molecules than the one comprised of molecules with a higher net charge.



## CHAPTER 13

### A CLOSER LOOK AT THE PROPERTIES OF LIGHT

The fundamentals of physics have now been fairly well outlined; however, this presentation is still far from complete. There are still many details which need to be filled in. This is especially true concerning the properties of light, despite the fact that the real meaning of Planck's constant has already been presented and its relationship to light has become apparent. How does the law of redistribution of energy work? What are the real principles behind color perception? Why is the velocity of light independent of its frequency? Why is this velocity equal to the ratio between an electromagnetic and electrostatic unit of charge? The answers to such questions have never been given before. Great fluctuations occur in the velocity of electrons in their orbits when materials are subjected to high temperatures. This, in turn, creates interactions and interference effects between electrons moving in opposite directions inside atoms and between electrons in adjacent atoms. These interactions generate changes in the electrostatic field effects of the electrons, which will cause regular and distinct changes in their so-called orbits. This is because the charge on the electron varies with its velocity. Abrupt changes in the velocity of a particle disrupt the ethers, which, in turn, results in the formation of photons. In one respect, the theorists did make a lucky assumption, but the "quantum jumps" of the electrons were the effects, along with the light produced, and not the cause of the spectral lines.

The larger the atoms, the more complex the interactions, and consequently, the more intricate the spectral pattern. The photons comprising the electrons determine the range of the ethers that can be disrupted. These ethers are intimately connected with the electrostatic field intensity of the electrons. Thus it follows from this new definition of Planck's constant, just why this definition must be taken into consideration in all of the calculations concerning the



frequency of light produced in interactions. This even holds for the discursive mathematical jugglings by mathematical physicists, and why they were able to account for some of the spectral lines from a quantitative aspect.

The definition can be clarified still more by keeping in mind the following: the electrostatic field effects around an electron are dependent upon the range and level of the ethers deflecting off the sides of the particles. This range is not necessarily the same as the range of ethers affected by sudden changes in the velocity of the electrons, but there is a direct correlation between the two. When electrons interact, some of the ethers deflected from the electrons will, in turn, interact directly or indirectly with other ethers that cannot contribute to the electrostatic field effects of the electron. In this manner, a tremendous range of ethers below that from which the electrons originated can be indirectly disturbed by the electrons, and Planck's constant plays a role throughout the procedure, since all ether particles have the same kinetic energy. Electrons cannot disturb ethers higher than those with which they are associated to the extent of producing harder photons and electrons because of the ultra-high frequencies required. This is in accordance with the fact that energy cannot flow uphill.

## **THE LAW OF REDISTRIBUTION OF ENERGY**

A more penetrating look at the law of redistribution of energy discussed earlier is now in order. Briefly, it states that when light interacts with matter, new light results with a lower average frequency than the original light. One of the simplest demonstrations of this law is done with the use of light filters. For example, a light beam in the blue or violet end of the visible spectrum, after passing through a series of filters, regardless of the types, will always emerge from the last one as red light, providing a sufficient number of them are used. These filters could be all blue, violet or any other combination.

It was shown in the previous section that when an electron or proton is activated, successively lower ethers are indirectly disturbed, resulting in the production of lower frequency photons. This is in accordance with the universal law which states that energy can only flow from a high potential to a lower one. The law of redistribution of energy is based on this principle. When light interacts with mat-

ter, many of the photons scatter and are dissipated, while others recombine during reflections to form soft particles.

These soft particles further interact with matter resulting in some of the original light being repropagated. It is the production of photons by the indirect disturbance of ethers that produces the lower frequency light resulting from the interactions of light with matter. The lower frequency light produced in turn interacts with matter to produce indirectly still lower frequency light. However, the intensity of such light rapidly decreases as the lower frequency levels are approached. It is the interactions of soft particles and their disintegrations which are the greatest factors in the direct and indirect disturbance of the ethers to produce new photons. The soft particles release hard electrons during disintegration and their interactions with matter and with each other disturb the ethers. In some instances the release of hard electrons can be violent enough to produce higher frequencies than those of the original light, as is indicated by the Raman effect.

It should be noted that the principles mentioned above are also responsible for inertia. This results when a change in velocity disrupts the normal flow of ethers around and through a body, which normally offers no resistance to steady motion below critical velocities, since the closing forces equal the forward resistance. The ethers are far more fluidic than anything experienced with matter. A disruption brought about by a change of motion tends to produce photons. This requires force or energy and inertia is an integral part of the manifestation of energy. It is natural for the ethers to resist any change in motion of an object, with just one exception. The exception occurs when a body has a net zero charge after being impregnated with a certain combination of energies. In this case, cancellation effects result and no magnetic field is produced when the body is accelerated; hence, there is no disruption of the ethers. As a result, the body will have zero inertia. This occurs during teleportation, which will be discussed in Part IV.

## **THE PHENOMENON OF COLOR**

All of the colors we normally see are combinations of different frequencies of photons. This follows from the discussion in the last section. When light is produced, a wide range of ethers is disturbed. The soft particles vary considerably in the type of photons which

combine to produce them. Each type is not uniform in size or stability, therefore, there is a continuous disintegration back into photons because of various interactions. This tendency for soft particles to group together is the primary reason for the difficulty in separating light into narrow frequency bands. As a result, a wide frequency range of soft particles and photons will tend to be grouped together. This means that bands of light in the blue, indigo, and violet ranges will contain other colors down to the reds, although the reds will make up only a very small portion. The eye sees only the dominant color and prisms cannot separate them. The famous color experiments of Edwin Land, about 40 years ago, proved this to be the case. This wasn't recognized at the time and different interpretations were placed on the results of these experiments.

An article written by Land, describing his experiments, appeared in the May, 1959, issue of *Scientific American*. These experiments destroyed a number of popular theories on color perception. Briefly, the Land experiments consisted of two black and white transparencies produced from black and white film, exposed to filtered light from two different parts of the spectrum. For example, one film might have been exposed to light in the upper part of the green portion, while the other was activated by a longer wavelength in the green. When the light which had exposed each film was passed through these transparencies, and the resulting images were then superimposed on a screen, the original scene which had been photographed by the different films appeared in full color.

Of course, it required certain conditions to produce the true color reproductions. For example, if the two wavelengths were too close together, the results would be different. If the longer wavelengths passed through the transparencies produced from the shorter wavelengths, and vice versa, the color reproduction would be reversed. In other words, objects that should have been red would be colored blue, green, etc. This shows these different colors were present in each part of the spectrum, and that the variations in the different parts of the transparencies did what normal attempts at separation of colors failed to do.

The experiments also show that it requires subtle combinations of frequencies for the eye to perceive color, when the light isn't in a narrow frequency band. Otherwise, the eye will see things in various shades of black and white. Shades of black and white contain all the colors, but in the wrong combinations to be seen as colors. This has

its parallel and analogy in sound. The blacks and whites or shades of gray correspond to dissonance and noise, while the colors correspond to harmonies and tones. The ratios of frequencies producing colors in light are the same as in the realm of sound which produce the tones and harmonies in music. This is just another demonstration of the 2nd Hermetic Axiom. This is why certain musicians, composers of the past, and some connoisseurs of music experience music in terms of color. This is natural, since the same consciousness and awareness is involved in the interpretation of each medium.

The Land experiments were completely baffling to everyone, since they seemed to violate all the rules of color perception. Land attributed the results to previously unsuspected abilities of the eye, and to reactions of the psychological nature, rather than to something having physical reality. Physicists, of course, remained silent. Land should have received a Nobel prize for his work, which was of far greater significance than many other contributions for which this prize was awarded. This is no mystery. Nobel prizes are not awarded for work that is disturbing to the scientific community.

It is evident there are a myriad of colors in the near monochromatic category, never seen on this planet. It is likely many such colors are visible in the Earth's interior. Many of the soft particles formerly bound together become separated and disintegrate during their passage through the Earth's shell. Some particles in a cluster will disintegrate before others do. This would produce color effects not observed on the surface. In addition, this will occur to a slight extent during the passage of light through the atmosphere, but not to a degree that will be perceptible. The book, *Etidorhpa*, described such a phenomenon in the Earth's interior. The term "primary color" is a misnomer. Each of the three primary colors covers a broad band of the spectrum, and is so situated that different combinations can produce all of the common colors of the visible spectrum. This is because each one contains all such colors in abundance.

## THE NATURE OF LASER BEAMS

Under certain conditions light reflected from a mirror is of greater intensity than the incoming light if it is of a sufficiently high intensity. It is simply a marvelous demonstration of the process described earlier

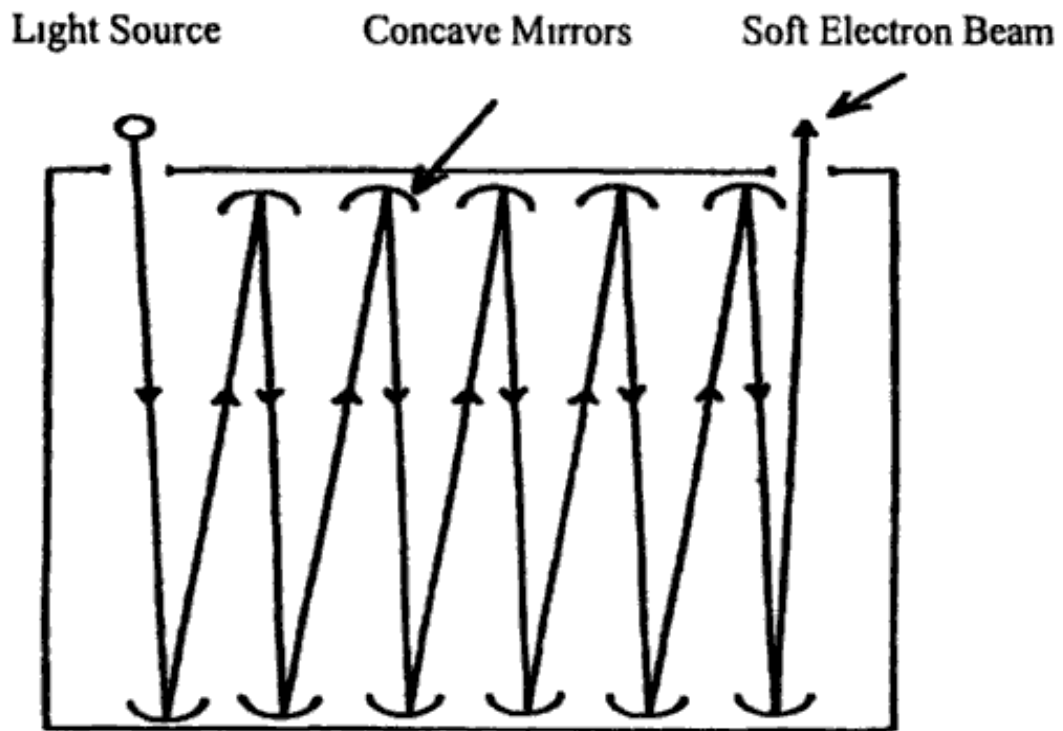

*FIG. 19: DEVICE TO CONCENTRATE SOFT ELECTRONS*

*A soft electron beam is generated by positioning mirrors so as to create multiple reflections. As the number of reflections increase, a higher percentage of the original light is converted into soft electrons. The type of soft electrons produced depends on the frequency of the original light.*

by which light photons are created. When the particles of the incoming light collide with the mirror, those that are reflected are instantly brought to a halt. This produces a tremendous disturbance of the ethers which results in the creation of new photons. They are added to the light that is reflected. In addition, many of the photons reflected and created combine during the process to create soft electrons. Consequently, light reflected from a mirror contain a higher percentage of soft electrons than the incoming light.

The above principle is also demonstrated by the introduction of a multifaceted reflecting surface in a room illuminated by a given light source. The room becomes illuminated to a far greater degree than it would with the light source alone.

It follows that repeated reflections of a light source such as the Sun would result in a highly lethal laser-like beam. This has been



demonstrated on numerous occasions. Perhaps the most notable occurred near White Sands, New Mexico, in the early 50s. It was witnessed by an acquaintance of a personal friend of the author, and it was something he wasn't supposed to have seen. About 35 four-foot mirrors were arranged such that after the 35th reflection from the Sun, the resulting beam was directed to the rock wall of a mountain. It immediately blazed a neat hole through 200 feet of solid rock!

An associate of the author recently found that by putting a strong negative charge on the mirrors, their reflective power is considerably increased. He charged a series of metallic mirrors to 20,000 volts and found that after 10 repeated reflections from the Sun, the resulting beam became very lethal. This shows that it is the negative charges deposited on a mirror surface that enables it to reflect most of the light that impinges on it. Incoming light immediately deposits negative charges on the surface, which repels the rest of the light. The more intense the incoming light, the higher the concentration of negative charges placed on the surface. This accounts for the fact that highly lethal beams reflecting from the surface do not destroy the mirror. A similar process is involved in fire walking discussed in Part IV.

The type of mirrors used in such an experiment must be metallic and preferably concave. Glass mirrors will not work. Much of the incoming light energy is lost during passage through the glass before it reaches the reflecting surface. Also some of the energy is lost due to reflection from the glass surface. Much of the shock effect of the light reflection is lost because of the slowing down of light passing through the glass. It is apparent the incoming light must hit the mirror in as near a perpendicular direction (or head on) as possible.

A soft electron beam is produced by positioning mirrors so as to create multiple reflections. After each reflection new photons (and subsequently new soft electrons) in addition to those in the incoming ray are created if the reflectivity of the mirror is adequate. When the incoming beam strikes the mirror the ethers are disturbed with the creation of new photons in the manner described in the text. If the reflectivity of the mirror were 100% each photon of the incoming light would create a new one during reflection. As a result, the reflected beam would have twice the intensity of the incoming beam. The reflectivity of the mirrors can be greatly increased by putting a strong negative charge on the mirrors. The incoming light tends to deposit a layer of soft electrons on the mirror, which enhances the reflection. The greater the intensity of the incoming light, the higher the

concentration of soft electrons deposited on the mirror. This means that if the intensity of the light source is below a critical value coupled with an inadequate reflectivity of the mirrors, the reflected rays will become progressively weaker instead of stronger. This is why repeated reflections inside two long mirrors facing each other will not work. During each reflection, the negative charges deposited on the mirror by an incoming ray is distributed over the entire mirror surface instead of being concentrated in a small area the size of the cross sectional area of the beam.

When an incoming light is of a relatively low intensity, the reflected light is not increased by as high a percentage as is the case with higher intensity light because the surface is impregnated with a far lower concentration of negative charges.

When a surface is rough, a protective layer of negative charges cannot accumulate on the surface to produce a significant reflection. The irregularities on the surface cause a scattering of photons and soft electrons in all directions which will dislodge particles that would otherwise stick to any given portion of the surface.

It is more than likely that Archimedes applied the above principle to set ships on fire with his "burning mirrors" when his homeland was being invaded.

The insight just presented points the way to a device of revolutionary significance. Mirrors placed in the proper positions inside a box can transform the light from any source of sufficient intensity into a beam of soft electrons of any desired degree of intensity. The range of application for such a machine would be mind-boggling. For example, soft electrons associated with colors known to be highly beneficial could be concentrated to produce rapid healing. This could render obsolete other healing devices proven to be effective. Also such a device could be used to rapidly curve out tunnels. Any kind of beam could be obtained for any type of job, depending on the frequency range of the light used. The intensity of the soft electrons can be regulated by controlling the number of reflections. Figure 19 illustrates this principle. It should be emphasized that the original light must be above a critical intensity in order for the reflected light to be of a higher intensity than the original.

## WHY THE VELOCITY OF LIGHT IS INDEPENDENT OF ITS FREQUENCY

Here is another aspect of light which physicists have seen fit to ignore. It is implicit in the Maxwell equations, but it still isn't explained. When the ethers are disturbed to produce a photon, a fraction of them are compressed and a great number are forced close enough together to adhere. This is analogous to the cohesive forces of atoms. The higher the ethers affected, the more rapidly and suddenly this temporary displacement must occur in order to form a photon. Otherwise, the ether particles will escape this compression since they are very active. This momentary compression of the ethers quickly returns to normal, much like a compressed spring that is released. This rebound hurls the aggregate or photon forward at the speed of light. The distance of this rebound of the ethers is equal to the so-called wavelength, or the distance in which the photon is accelerated to the speed of light.

The same identical pattern occurs when still lower ethers are disturbed to produce a lower frequency photon, except that the rebounding of the ethers takes place over a greater distance with a lower average acceleration of the photon produced. Since the warped condition in both cases follows identically the same pattern, the use of average acceleration can be applied in the following analysis to show that both photons reach the same velocity.

In the following derivation, let (a) represent the average acceleration of the larger and lower frequency photon while (a') is that of the higher frequency photon. Let (t) be the time required for the larger photon to reach its maximum velocity and (t') the time required for a smaller or higher frequency photon. Now (a') equals (na) where  $n > 1$ . From elementary mechanics, the distances through which the restoring forces operate in the case of both the lower and higher frequency photons are  $\frac{1}{2} at^2$  and  $\frac{1}{2} a't'^2$ , respectively. Since the average restoring force or acceleration is a linear function, the conclusion is that it is directly proportional to the frequency of the light produced; therefore, inversely proportional to the so-called wavelength. This of course is in keeping with Planck's constant. Now,  $\frac{1}{2} at^2 = n (\frac{1}{2} a't'^2)$ . Substituting (na) for (a') in this relation, it follows that  $at^2 = nat'^2$  or  $t = nt'$ . Since a't' and at are the terminal velocities attained by the higher and lower frequency photons  $t = nt'$  and  $a =$

$a'/n$ . It follows that  $a't' = at$ , which means that any two photons will always reach the same velocity in free space regardless of their frequency.

## THE BASIC PROPERTIES OF LIGHT

It was stated earlier that photons of light are produced when the ethers are disturbed in such a way that ether particles are forced close enough together and for a sufficient period, for them to adhere to each other. During the process, other ether particles in the vicinity are crowded more closely together than normal. The tendency for the ethers in the region affected to return to the normal state causes an unbalanced force on the photon just created. As a result, it is propelled at a high velocity. Since ether particles are extremely active, the action which produces photons must be correspondingly rapid and of short duration. The more active the ether particles, the higher the frequency required for the formation of photons.

In the external universe it is a well established fact that every object has a certain natural frequency. In other words, there is a certain frequency of vibration that it responds to. The greater the mass, the lower the frequency of response. The same pattern applies to the ethers. The lower ethers, consisting of larger and more massive particles, will respond to a lower frequency pattern than will the higher ethers. For a given force, the acceleration imparted to a given mass is directly proportional to the magnitude of that mass. Since the velocity of light is independent of its frequency or so-called wave length, the relative masses of the ether particles comprising photons of different frequencies can be determined. Light of a given frequency consists of moving photons separated by intervals of a certain length. The length of this interval plus the diameter of a photon is what is known as the "wave length". This is the distance through which the photon is accelerated by the restoring forces of the ethers which gives it light velocity. Since light is produced by the interactions of the fundamental particles of the atoms which are the same in all cases, it follows that the average accelerating force disturbing the ethers is also the same. Therefore, the lower ether particles having a great mass will be accelerated at a lower average rate than the higher ethers. From this fact, it would follow that the acceleration time is

inversely proportional to the average acceleration of the photon. The distance through which the photon is accelerated is equal to  $\frac{1}{2} at^2$ , where  $a$  is the average acceleration and  $t$  is the time of acceleration. This means that if the mass of the photon is doubled becomes half as great while  $t$  is doubled. Therefore, the "wave length"  $\frac{1}{2} at^2$  doubles. It can be concluded that the frequency of light is inversely proportional to the mass of its photons or the mass of the ether particles comprising the photons.

## **WHY THE VELOCITY OF LIGHT EQUALS THE RATIO BETWEEN EMU AND ESU UNITS OF CHARGE**

The behavior of electrons or protons in an accelerator shows that at the speed of light all of their electrostatic potential has been transformed into magnetic energy. From the law of conservation of energy, it follows that the total kinetic energy of the ethers that produced the magnetic field is the same as the total kinetic energy of the bombardment of the ether particles producing the electrostatic field, when the particle is at rest. Now it is possible to understand why the velocity of light relative to its source is the ratio between the EMU and ESU units of charge.

The electrostatic unit of charge (ESU) is a charge which will produce an electrostatic force of one dyne on a like charge one centimeter away. The electromagnetic unit (EMU) is a charge which, when traveling at a velocity of one cm/sec, will produce a magnetic field that will exert a magnetic force of one dyne on a unit pole or a similar charge traveling at one cm/sec at a distance one centimeter away in its equatorial plane. This is purely a hypothetical case, since two such charges one cm from each other would exert an electrostatic force of  $10^{11}$  tons on each other.

It is evident that the total energy of the magnetic field around one EMU of charge, traveling at one cm/sec is equal to the electrostatic energy potential around one ESU of charge; since they exert similar forces and are capable of doing the same amount of work. They are merely in different forms, as has already been shown. It follows from the relationship between electrostatic and magnetic fields that the EMU charge, traveling at one cm/sec, will have an equivalent of



one ESU of its charge transformed into magnetic energy. Since the electrostatic charge moves with the particles or mass of particles having the charge, the amount of electrostatic energy transformed will be directly proportional to the velocity attained.

This is analogous to a spaceship propelled by rocket fuel in free space. Assuming the mass of the fuel is negligible when compared to the mass of the ship, the fuel will be expanded at a constant rate to give the ship a constant acceleration. This means that the velocity attained at any moment will be directly proportional to the amount of fuel consumed.

As mentioned before, the behavior of particles in accelerators shows that when all their electrostatic energy is transformed into magnetic energy, they will be traveling at the speed of light relative to their source. This can also be deduced from the manner in which light is produced. At that moment the ethers that are disturbed to produce a photon start to rebound, they begin to accelerate the photon. The ether bombardments on the photon represent the electrostatic force. By the time the ethers return to normal, this electrostatic potential has been transformed into magnetic energy of the photon traveling at light velocity.

An ESU of charge, with all of its electrostatic charge transformed into magnetic energy, will be traveling at the speed of light. An EMU of charge with only one ESU of this charge transformed will be traveling one cm/sec. Since the velocity attained is directly proportional to the amount of the electrostatic potential transformed when two ESUs of its charge are transformed, it will be traveling two cm/sec. When  $c$ , or  $3 \times 10^{10}$  ESUs of its charge are transformed, it will travel at the velocity of light, or  $3 \times 10^{10}$  ESUs of charge will equal the energy of one EMU of charge at light velocity. Therefore, the velocity of light relative to its source in cm/sec equals the ratio between an EMU and ESU of charge or  $EMU/ESU = c = 3 \times 10^{10}$  cm/sec.

This highly interesting fact is an outgrowth of the relationship between electrostatic and magnetic fields and is one of the most important laws in the universe. It is indeed incredible that this conclusion was derived from Maxwell's equations which are in part based on an assumption diametrically opposed to the relationship between electrostatic and magnetic fields. It shows a theory can be wrong, yet still hit the truth occasionally, as quantum mechanics has in regard to atomic spectra. The Maxwell equations are perfectly

compatible with the Lorentz transformation equations of Special Relativity. This is one of the major reasons Relativity has been universally accepted by physicists. This compatibility is not surprising. Both the Maxwell and Lorentz equations conform with the idea that the charge on a particle is constant.

In the above demonstration it was stated the velocity attained during the transformation of electrostatic energy into magnetic energy was directly proportional to the amount of electrostatic charge transformed into magnetic energy. This is in accordance with the principle that the kinetic energy of a moving body is manifested in the magnetic field developed around it. It is assumed a body of mass,  $m$ , has a certain amount of its charge transformed to give it a velocity,  $v$ . The velocity, of course, is directly proportional to the amount of charge transformed. For the sake of simplicity, it is assumed that the transformation is taking place at a constant rate, i.e. the acceleration is constant. Let  $(t)$  be the time required for this transformation. The velocity  $v = at$  and the average velocity during this period is  $\frac{1}{2} at$ . The distance covered  $= \frac{1}{2} at \times t = \frac{1}{2} at^2$ . The energy or work required to accelerate the mass to velocity  $v$ , or to transform the electrostatic charge equals the force exerted on the mass  $m$ , acting through the distance  $\frac{1}{2} at^2$ . This force  $= ma$ . Therefore, the energy required is  $ma(\frac{1}{2} at^2) = \frac{1}{2} m(at)^2 = \frac{1}{2} mv^2$ . This is the kinetic energy of the mass,  $m$ , and it is also the energy of the magnetic field around it. In order for the energy conservation law to hold, it must be concluded that the kinetic energy is manifested in the magnetic field.

This can also be shown from entirely different considerations. Within certain limits, the intensity of a magnetic field around a moving charge varies inversely as the square of the distance from the center of the charge. This distance is in a direction perpendicular to the direction in which it is moving. Let  $E$  represent the amount of charge transformed. Then the magnetic intensity at distance  $r = E/r^2$ . As  $E$  increases, how much does the extension of the field increase? Let  $r$  represent the outer limit of the field for the value,  $E$ . When  $E$  increases by a factor of  $n$ , we have  $E/r^2 = nE/r'^2$  where  $n$  is the outer limit when  $E$  increases to  $nE$ .

$$\text{Therefore, } r'^2 = r^2n \text{ or } r' = r\sqrt{n} .$$

As the body moves through the ethers, the vortex disturbance has a radius represented by the above relation. The ethers set into a vortex

motion by the passage of the body do not return to normal immediately after it has left the region disturbed. There is a definite time lag. This means the length of the vortex is directly proportional to the velocity of the body. Therefore, as  $E$  increases by a factor of  $n$ , the volume of space affected or occupied by the magnetic field increases by a factor of  $n(\sqrt{n^2})$  or  $n^2$ . Since  $E$  is directly proportional to the velocity, it follows that the volume of the field varies as the square of the velocity.

The average field intensity within the volume is independent of the velocity since  $E/r^2 = nE/r'^2$ . Since the energy of the field equals the average field intensity multiplied by the volume, it can be concluded that the total energy of the magnetic field produced by the motion of the body varies as the square of its velocity. This provides, for the first time, a graphic illustration of the mathematical formula for kinetic energy. When any mass is given an acceleration, all of its fundamental particles are given a certain additional spin perpendicular to the direction of motion of the body. This is compounded with their normal motions within the atoms and molecules of the mass. The additional magnetic field resulting permeates the entire mass.

It also becomes evident that the rotational velocity of a particle producing a magnetic field is directly proportional to its translational velocity. The analogy represented above regarding the rocketship and fuel expended to give it a velocity represents a paradox impossible to resolve with conventional science. During the acceleration of the ship, kinetic energy is increasing with the square of the time, while the amount of energy expended to produce the kinetic energy varies directly with the time. From the standpoint of orthodox science, there is a definite violation of the law of conservation of energy. A lot more energy is derived from the kinetic energy of the ship than was used to generate it. This paradox has never been resolved, and physicists cope with it by ignoring it.

When an electrostatic field is transformed into a magnetic field, the total energy of the ether particles involved is not changed. All energy in the universe is a result of the motion of ether particles. The energy of motion of the ether particles, before the spaceship is accelerated, is the same as the total energy afterwards. Only the direction of motions has been changed. Therefore, there is no violation of the law of conservation of energy. The reader can see this paradox

substantiates the existence of the ethers described, and also the nature and relationship of electrostatic and magnetic fields.

The principles regarding the relationship between an EMU and an ESU of charge provide a means of calculating the ether pressure exerted on a single hard electron at rest. Obviously, the percentage of total ether pressure on the particles transformed into an electrostatic force is dependent on their relative distance from each other. The inverse square law for electrostatic force is valid only within certain limits. More than likely, a single electron will induce zero force on another electron one centimeter away.

An EMU charge traveling at one centimeter per second will have one ESU of its charge transformed into magnetic energy. This is equivalent to an ESU charge traveling at the velocity of light. In this case, the normal ether pressure or ether bombardment has been entirely transformed into a rotary motion around the particles comprising the charge. This means that the ratio EMU/ESU of the total ether pressure exerted on the charges comprising the EMU charge traveling at one cm/sec has been transformed to produce a magnetic force of one dyne on an ESU charge one centimeter away traveling at light velocity. The energy involved is identical to the electrostatic force an ESU charge exerts on a like charge, one centimeter away. From the law of conservation of energy it follows that the ratio EMU/ESU of the total ether bombardment on the particles comprising an ESU charge has been transformed into the electrostatic force! This means that the ratio EMU/ESU dynes, or approximately  $3 \times 10^{10}$  dynes total ether pressure is exerted on the particles composing the ESU charge. The charge on a single electron has been measured at  $4.8 \times 10^{-10}$  ESU. This means that there are  $2.08 \times 10^9$  electrons in an ESU charge. Therefore, 14.4 dynes total pressure is exerted on a single electron by the surrounding ethers. This represents a pressure beyond normal comprehension when the minute size of an electron is considered.

## **CHAPTER 14**

# **THE ROLE OF SOFT ELECTRONS IN PROMOTING CHEMICAL CHANGES AND MAINTAINING LIFE, AND THE PYRAMID PHENOMENON**

## **SOFT ELECTRONS, MAGNETIC FIELDS, AND CHEMICAL CHANGES**

Much has already been said about the importance of soft particles in all phases of our existence. However, a more extensive treatment of this subject needs to be given. It has been repeatedly confirmed that magnetic fields have considerable healing properties and will stimulate plant growth. What has not been realized is that it is not the magnetic fields themselves which are responsible, but the soft electrons they capture and concentrate. Another phenomenon of magnetic fields puzzling many is that one pole of a permanent magnet has beneficial effects for certain ailments, while the opposite pole is not as effective.

For open wounds and sores the pole into which the lines flow seems to produce deteriorating effects while the opposite pole produces the opposite. In such cases one pole draws the vital energies away from the surface while the opposite pole pushes them in. For deeper afflictions, the pole into which the lines flow seems to work better. Something akin to the Coanda effect is produced which produces a rapid flow.

One of the most significant properties of soft electrons is their ability to promote chemical changes. As mentioned previously, the electrostatic zonal effects around atoms and molecules determine, in part, their chemical and physical properties. A change in a molecule is not likely to take place without lessening the chemical bond or attraction among its constituent atoms. Soft particles interpenetrating the molecule will bring about this condition by carrying harder electrons in with them, which in turn will weaken this bond by off-



setting the positive charge effects of the nucleus. Soft particles tend to camouflage a variety of harder particles. This is a vitally important property because, in this manner, other atoms, which are going to take part in the chemical change, also have their zonal effects temporarily altered, so they can come into more intimate contact with the reaction. The soft particles tend to act as catalysts for the reacting particles. This has a tendency to disintegrate the soft particles involved. The release of energy then expedites the reaction. The disintegration of the soft particles also allows the normally powerful electrostatic field effects within the atom to return to their original state.

For any type of charge, the right kind and concentration of soft particles can accelerate the reaction hundreds, even thousands of times faster than the rate at which it would normally take place. The disintegration of soft particles involved in chemical changes and the release of hard electrons is the source of much of the heat produced during chemical reactions.

## **THE PROPERTIES OF WATER**

Special types of particles radiated by catalysts, such as platinum, are responsible for their ability to promote chemical changes. It should be mentioned that the chemical properties of atoms and molecules are, in part, governed by the soft particles they radiate. Water is a universal catalyst, because of its unique ability to collect and concentrate an enormous quantity of soft electrons of all kinds. This is the reason water has the highest specific heat of any known substance.

The great amount of energy contained in water, in the form of soft particles, has been unwittingly demonstrated by experimenters on many occasions. For example, there are a number of reports of internal combustion engines running on water treated with a minute quantity of some undisclosed chemical. The engines in each case performed as well as they would have on gasoline. Such a demonstration was supposedly witnessed under controlled conditions by the Navy Department during World War I. Franklin D. Roosevelt was also allegedly involved. The man who had the secret was named Andrews. He disappeared after the demonstration under mysterious circumstances. There have been many rumors of others. It doesn't

require much imagination to realize what happened after such discoveries were made known. The universal application of such discoveries would have wrecked the petroleum industry.

Of course, no reasonable explanation could be given for this phenomenon, since it seemed to be contrary to all the rules of chemistry. The explanation is apparent in light of the principles involved. The chemical was the deciding factor in triggering the disintegration of the more unstable soft particles contained in the water when the atomized solution was subjected to compression and ignition inside the engine.

Recently an associate sent the author a copy of an article a newspaper reporter, Tom Valentine, wrote for a newsreel series. According to the article, this reporter personally witnessed an incredible demonstration by an eccentric individual named Guido French in April 1973. The reported was allowed to pour nearly a gallon of water that he, himself, had obtained, into a clear glass jug. French then dumped a teaspoon of tiny, evergreen granules into this jug. The granules quickly dissolved, followed by a rush of air from the opening which French claimed were oxygen molecules. The mixture in the jug became a light evergreen shade. French then stated that this liquid would not mix with water any more. To prove his point, he mixed water and some of the green liquid in a test tube. They wouldn't mix and the green liquid floated on top of the water showing that a tiny amount of powder had lowered the specific gravity of the water. French then showed that the green compound would burn clear, leaving no residue. French, it seems has given hundreds of such demonstrations over the past 40 years, but will not divulge his secret. He has conned hundreds of "investors" out of large sums of money.

The experiment given by French is a demonstration of principles already discussed in this treatise. For one thing, it showed that specific gravity is dependent on the charge of the atom or molecule. Not enough oxygen escaped to account for any significant loss in weight from a conventional viewpoint. This means that a number of water molecules combined with a molecule of the green powder to form a new molecule with the release of an oxygen atom. The overall positive charge of the new molecule was lessened with the loss of the highly, positively charged oxygen atom. However, the soft electron concentration was unchanged. Since the new liquid did not have the capability of water to hold the soft electrons it contained, high concentrations of them could be released with little provocation. Consequently, this

would result in the disintegration of large quantities of soft electrons with the production of much heat. In other words, the green liquid would be highly flammable.

A seeming paradox may come to mind, concerning the properties of water. Since water contains a high concentration of these particles, then why isn't the weight and inertia of water affected? The concentration of soft electrons fluctuates considerably, yet the weight and inertia don't. This question is appropriate, and once again the answer is simple. Water contains vast quantities of soft electrons of all kinds, from the ultra soft (comprised of very low frequency photons) to the much harder comprised of photons of the ultra-violet and beyond. The softer particles tend to gobble up and camouflage the harder ones. This means that the soft electrons that can change the weight and inertia of water have been absorbed by softer electrons that have little or not effect on the weight or inertia of water. Such particles, however, are highly unstable. When water is agitated, these particles readily disintegrate and release the harder particles. This accounts for the phenomena to be described later in this chapter.

A paradox seems to exist with regard to clouds. They consist of small water droplets that do not fall. From the standpoint of the properties of water just presented, they should fall. Every water droplet is attached to a dust particle. This dust particle absorbs a high concentration of negative charges from the water. The particle would levitate upward, were it were not for the water droplet holding it down. If the amount of water around this dust particle exceeds the critical amount, the droplet will fall as rain. Outer space is permeated with fine dust that continually replaces the dust taken out of the atmosphere by precipitation. This dust is vital to sustaining life on a planet. Without it, there would be little or no precipitation.

Under certain conditions, water can lose weight and even levitate. Experiments have shown that water, when ejected in the form of fine jets, will start to levitate after falling a certain distance. Also, the fine spray resulting from waterfalls often has a tendency to levitate upwards. This phenomenon has puzzled many observers. By now the reason is obvious. Such conditions cause the water droplets to be impregnated with an inordinate concentration of soft electrons. Also, the turbulence causes a greater number of hard electrons to be released within the water.

The reason water has a great affinity for soft electrons must be made clear. Water is a unique substance. It is comprised of two elements among the most chemically active and are gases. In fact, it is the only stable compound which is a liquid at normal temperatures, and whose molecules consist exclusively of gaseous elements. The fact that three oxygen atoms can magnetically combine to form an ozone molecule indicates that the oxygen atom is extremely magnetic. This means that a higher percentage of its orbital electrons are moving in approximately the same plane. This leaves fewer orbital electrons tending to offset the positive charge of the nucleus and other portions of the atom. Consequently, two sides of the oxygen atom possess an inordinately strong overall positive charge. When the hydrogen atoms combine with an oxygen atom, the electrons on the side of the hydrogen atoms adjacent to the oxygen atom are brushed aside. (This is on the segment of the oxygen atom where most of the electrons of the oxygen atom are orbiting). The normal flow of electrons around the proton of the hydrogen atom are diverted to a flow which encircles the oxygen atom and the outer periphery of the hydrogen atoms. This results in a powerful bond between the hydrogen atoms and the oxygen atom which is both electrostatic and magnetic. The electron flow around the hydrogen atoms is extremely rapid. As a result, the overall positive charge of the hydrogen atoms in this case is very high. Since there is a very strong mutual repulsion between them, they will line up on opposite sides of the oxygen atom. Thus the water molecule has the structure H-O-H.

The molecule created from this combination has strong and extensive positive zones. The attraction zone is consequently a considerable distance from the molecules relatively speaking. This is why the specific gravity of water is low despite the strong positive charge of the molecules.

The great affinity of water for soft electrons is now apparent. The large, positive zones between molecules are havens for soft electrons, drawn there by the attenuated, but significant, attraction of the hard electrons captured by the soft electrons. Although soft electrons are large compared to hard electrons, they are still very small compared to an atom. Therefore, the spaces between water molecules can harbor large quantities of soft electrons, without their being bound to the water molecules.

Other properties of water can be more readily understood, when the conditions determining whether a substance is a gas, liquid or solid is analyzed. Two given atoms or molecules will attract each other, when the electrostatic forces favoring attraction overbalance the repulsive forces. At any relative position, there are repelling forces tending to counteract the attractive forces. It follows there is a position in which the resultant attractive force is at its zenith. This means there is a zone around any two atoms or molecules where the attractive forces are greater than the repulsive forces. All other areas are repulsive zones. A substance is in the gaseous state when the average kinetic energy of all the molecules is sufficient to carry them past the zone of attraction, regardless of their relative positions. The molecules of a substance which is a gas at normal temperature have attractive zones that are relatively weak and of limited extent. When the substance becomes a liquid, the average kinetic energy of the molecules is not great enough to take them beyond the zone of attraction when they are grouped close together. The attractive zone, however, is not great enough to confine them to a small area and, as a result, they have a relatively wide range of movement. Due to the Maxwell distribution law, a certain percentage of the molecules, at any instant, have a velocity that enables them to escape from the surface of the liquid, and evaporation is the result. In the completely solid state, the kinetic energy is too low to allow any molecule to move a significant distance after it enters the zone of attraction, and its motion is confined to an extremely limited area. Evaporation can, and does, take place under certain conditions when molecules occasionally reach sufficient velocity to escape from the surface, as in the case of ice.

At extremely low temperatures all substances, especially under pressure, become solid and brittle, since practically all molecular activity ceases. A slight displacement of molecules at any portion of the substance, due to stress, produces a break, since the molecules at this point of stress are not moving far enough or fast enough for a significant portion to stay in the zone of attraction, before a break can occur. Any substance, regardless of how brittle it may be, will stretch a certain amount before a fracture occurs. The distance of stretch depends on the extent of the zone of attraction. A ductile and flexible substance consists of molecules with relatively large zones of attraction, and the molecules have a wide range of movement.



If a substance receives no soft electrons from the exterior, those contained within it either escape or disintegrate. Soon all molecular activity dampens, and finally ceases, as the temperature is reduced to absolute zero. The soft electrons produced by the activity of the fundamental particles leave the material without disintegrating, therefore do not contribute to any molecular activity.

Perhaps the property of water that has been the most baffling, is that it expands as it freezes. It is unique in this respect. The principles introduced above easily resolve the mystery. The high concentration of soft electrons greatly weakens the repulsive and attractive forces between the molecules. Therefore, the average kinetic energy of the molecules at the freezing point are still of sufficient magnitude to enable the molecules to move in and out of the zones of repulsion and attraction, without being confined in the attraction zone. The cooling process must proceed until the soft electron concentration reaches the stage where the attractive forces become strong enough to confine the molecules to the attractive zone. When this occurs, the water becomes a solid. Since the attractive zone is an inordinate distance from the molecules, the average distance between molecules becomes greater than it was when the water was in the liquid state. At the freezing point, the molecular activity is low enough to permit soft electrons to enter or leave the substance without disintegrating. This means, in order for the water to be transformed from a solid back to a liquid, the same quantity of soft electrons must be injected into it as were removed, when it changed from a liquid to a solid. Both processes occur without a change in temperature, because the disintegration of soft electrons is minimal at this stage. When the concentration becomes greater, the disintegration rate increases sharply, and the temperature rises as a result.

There is another phenomenon concerning water and other substances, which has not been widely discussed or written about, let alone explained. It is that the melting and freezing points are not constant, but fluctuate considerably, depending on conditions. For example, water can still be a liquid at temperatures considerably below 0° Centigrade, the temperature which nearly everyone believes is the freezing point. As a matter of fact, this temperature was accepted as the official freezing point, because it was found to be the maximum temperature at which water freezes without being subjected to high pressures.

The soft electron concentration in a given area can vary without the temperature changing. A residual pocket with a high concentration of stable, soft electrons can reduce the normal repulsive and attractive forces between the molecules of water at 0° centigrade and below to the extent it is still a liquid. This means the thermal agitation of the molecules must be reduced further in order for the water to freeze.

Another phenomenon concerning water, never explained and thus ignored by science, is that in cold weather hot water pipes have a greater tendency to freeze than cold water pipes. The heating of the water drove off many of the soft electrons, normally harbored within the water. Due to the low temperature of their surroundings, the soft particles were not replaced. Therefore, when the water in the hot water pipes approached the normal freezing point, it did not have to go through the process that the unheated water had to, in order to transform from a liquid to a solid at the freezing point.

Of all the strange properties of water, its expansion as it freezes is something conventional science has been unable to ignore. The accepted "explanation" is that as the water freezes, the molecules arrange themselves to form crystals. This particular arrangement is in a geometrical configuration, supposedly resulting in fewer molecules per unit volume. As usual, the conventional explanation consists only of descriptions without any consideration of the causes.

The properties of water as a solvent, ionizer, and catalyst have now become understandable. When a soluble substance is placed in water, the cohesive bond between the molecules is broken by the presence of the high concentration of soft electrons carried in the water. The zones of attraction disappear, and the individual molecules are free to move around like the molecules of a gas.

A similar condition exists when a compound is ionized by water. Not only is the cohesive bond broken, but a chemical bond is also broken. With the two portions of a molecule separated, one part has a stronger affinity for orbital electrons than the other. Potentially, it then has an overall negative charge, while the other part losing some of its electrons to the other has a potentially positive charge. These charges are camouflaged by the high concentration of soft electrons in water. The condition is similar to the capture of hard electrons by softer electrons. Electrostatic attraction and repulsion between ions is almost completely nullified.

One generally thinks of colloids as the ultra-small particles of solid matter. However, molecules of water can adhere to each other to form aggregates of water molecules. Such aggregates are essentially colloids also. Colloids have strong electrical properties as indicated by the fact they are not affected by gravity. The field zones around a water molecule are not uniform and there are positions water molecules can assume in relation to each other by which they can cohesively adhere to each other to form a colloid of water. By the additive process as described in Chapter 9, the fields around such particles will be much stronger than around a single molecule. It follows that water with a high percentage of such colloids will be more potent than ordinary water since it will capture greater quantities of soft electrons. Abnormal conditions in certain portions of the Earth can favor the creation of water colloids. This can account for the healing properties of water found in some regions such as Lourdes in France.

As mentioned previously, soft electrons make chemical changes possible. It then follows that a catalyst supplies soft electrons necessary for chemical reactions. Metallic catalysts such as platinum supply the soft electrons needed to promote chemical reactions in two ways. First by the soft particles that continue to radiate and by the soft electrons that are drawn to and concentrate around metals especially those such as platinum whose atoms have abnormally high positive charges. Therefore, water which contains soft electrons of many different kinds should be a great catalyst. In fact, the property of water to capture and concentrate these soft electrons renders it the most versatile of catalysts. It is this property of water that gives its life-sustaining ability. In fact, any living organism can survive and actually thrive without water if it is continuously bombarded with the right type and right concentration of soft electrons.

## **HOW HARD PARTICLES ARE CAPTURED BY SOFT PARTICLES**

The capture of hard particles by softer particles has been discussed throughout this treatise. This fact is of transcending importance. It is deeply involved in a wide range of phenomena, from the transmission of heat and electricity to the formation of clouds. A detailed analysis of this process will now be presented.

Ether particles have zones of attraction and repulsion, as do atoms and molecules. This is in accordance with the 2nd Hermetic Axiom, and makes possible the formation of photons from ether particles. Since photons are comprised of ether particles, they will in turn possess zones of attraction and repulsion. In the case of ether particles, these zones will be correspondingly smaller in proportion to the diameter of photons. When photons combine to form electrons or protons, the same zones are present between these particles. However, the zones of attraction are minute, when compared to the diameter of the electron or proton, and like particles seldom, if ever, get close enough together at sufficiently low velocities for the attractive forces to become effective. The situation is entirely different when two like particles comprised of photons approach each other with widely differing frequencies. Electrostatic repulsion or attraction is considerably lessened, because each is associated with ethers which differ considerably from each other. When they are in direct contact with each other, electrostatic repulsion tends to vanish, since there can be little or no ether bombardments on the sides facing each other. Since each particle associated with ethers is somewhat different, they will tend to interpenetrate. This means they will be completely within the ether attraction zones of one another. As a result, the harder particle is captured by the softer one.

In like manner, the captured harder particles will, in turn, capture still harder particles, and they will likewise capture still harder particles. This process continues until the hard electrons normally associated with electricity are confined. This combination of particles tends to nullify the electrostatic forces which are normally produced by the confined particles. This tendency to nullify electrostatic forces will tend to camouflage the captured harder particles, so that their presence is not readily apparent.

The ether particles normally bombarding the hard electrons and protons which produce electrostatic field effects tend to be diverted from their normal paths by the presence of softer particles, or mediums between the repelling like charges, or the attracting unlike charges. The interpenetrating softer particles produce an ultra-high concentration of ether particles around the hard particles. The motion of these ether particles is greatly restricted. This offers a barrier to the higher ether particles that normally bombard the hard particles. This has a tendency to slow them down, and those that do collide with the hard particles do so with considerably less impact than

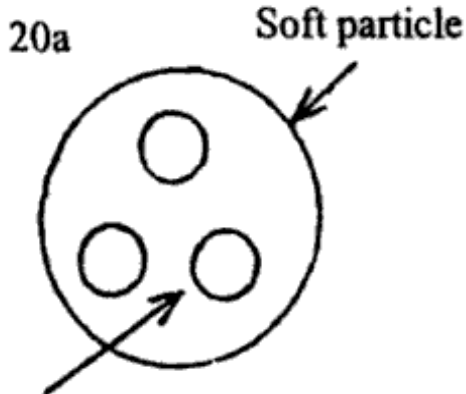

Harder particles

Two particles differing greatly in the frequency range of photons of which they are comprised have little tendency to repel or attract each other. Therefore, they tend to interpenetrate.

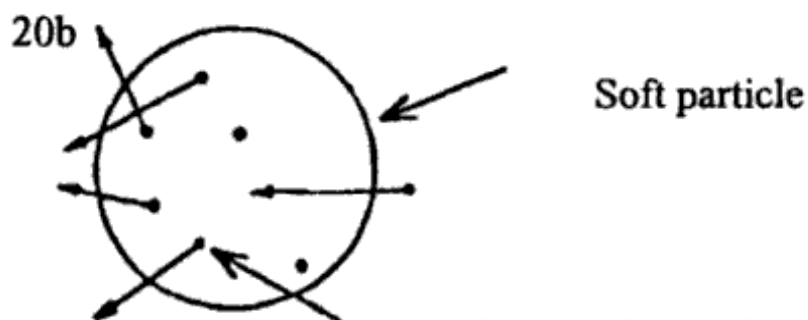

Extremely hard particles pass through without being captured

Since there are zones of attraction and zones of repulsion between ether particles, it follows that when two like charges are close enough, they will attract each other. Charged particles have the same properties as other particles because they are comprised of photons which are in turn comprised of ether particles. Normally, particles comprised of the same frequency photons never approach each other close enough for a long enough time to attract. However, particles which differ considerably in the frequency range of the photons of which they are comprised satisfy the conditions for entering the zone of attraction. There is a slight attraction upon reaching this zone which increases as the particles interpenetrate. Finally, the softer particle tends to capture and hold the harder one. If the frequency difference is too great, the soft particle is unable to hold on to the harder one, and the harder particle passes readily through it without being captured.

*FIG. 20: THE MANNER IN WHICH SOFT PARTICLES CAPTURE HARDER PARTICLES*



20c



Harder particles captured  
by the original soft one

Still harder  
particles  
captured by  
the previous  
captured  
particles

If the hard particles shown in 20b encounter particles which have already been captured by the soft particles, they will tend to be captured because the frequency difference of the constituent photons is not as great.

20d

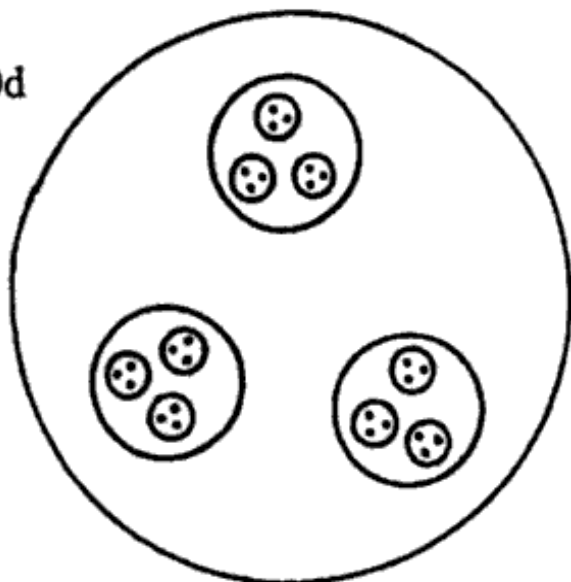

The process in 20c continues with the capture of still harder particles until a conglomerate of particles within particles exists.

The capturing process tends to nullify the electrostatic field effect of the captured particles. Electrostatic forces are the result of a disruption of the random movements of ether particles. The combination described above partially restores this randomness in the vicinity of the particles. When the disintegration of a soft particle occurs, a chain reaction generally takes place. The soft particle destruction releases the captured particles and the energy released results in their destruction. In turn, still harder particles are released and so on down the line.

*FIG. 20: THE MANNER IN WHICH SOFT PARTICLES CAPTURE HARDER PARTICLES (CONTINUED)*

normal. Therefore, they tend to become electrically neutral and their motion nearly slows to a halt. Soft particles also permeate matter, as well as the spaces between matter, yet they do not to any great extent neutralize the electrostatic field effects of the fundamental particles, because they are more concentrated, and also their rapid motion tends to prevent capture. However, additional concentrations of soft particles of the right kind, injected into matter, can render the elementary particles within the atom electrically neutral and the matter becomes what is known as "dematerialized". This is discussed in more detail in the chapter on teleportation in Part IV. The conglomeration of soft and hard particles, also by the above process, renders the soft particles electrically neutral.

It should be noted that only hard particles or the fundamental particles of the atom are hollow. All other particles, including photons, do not have this tendency because of the nature of their formation. If the softer particles were hollow, they would be unable to capture harder particles. Hard particles entering a hollow, soft particle would, of course, maintain their charges and force a mutual repulsion. Therefore, they would immediately escape. Photons, if hollow, would tend to be less stable, and the probability of forming other particles would be lessened.

When a soft particle disintegrates, a chain reaction ensues. The disintegration releases the confined, harder particles. The energy released during the disintegration is generally sufficient to disintegrate the weaker hard particles it originally captured. This, in turn, results in the disintegration of still harder particles, until the very hard and stable electrons of electricity are released. It was mentioned that the hardest particles were directly created by the great mind power of the Logos. They, therefore, possess far greater stability than do the other particles, and will not disintegrate during the process which started with the disintegration of soft particles. Figure 20 depicts the capturing process.

Highly interesting experiments performed in Poland during the summer of 1927 by two scientists, Howsky and Groot, demonstrated the ability of soft electrons to house and camouflage harder electrons, and to release them under certain conditions. These experiments also were a great confirmation of other principles which have been elaborated upon in this treatise, and especially those involved with levitation.

A small quartz crystal was attached to an oscillator which transmitted radio frequencies of several kilowatts. During the transmission, the quartz crystal lost its transparency and increased its volume 800 percent. The crystal then levitated and carried the oscillator, as well as a 55 pound weight suspended from it, to a height of two meters above the floor of the laboratory. An account of this incident appeared in an issue of *Science and Invention* magazine. A photo showing the experiment and the levitating process was included.

The levitation occurred when the crystal was subjected to vertical oscillation pressure, via direct electrode contacts and transverse oscillation, via non attached electrodes, broadcasting radiation, with the crystal interposed between them. The experiments were performed at low temperatures.

The properties of a crystal are discussed in Chapter 21. A crystal is essentially a glorified condenser. When the small crystal, mentioned above, was bombarded from all sides by low frequency photons and soft electrons from the oscillator, it was impregnated with an overcharge of hard electrons associated with a wide range of ethers. These electrons resulted from the disintegration of the soft electrons, penetrating the crystal. The overcharge forced the molecular layers of the crystal further apart, causing it to expand. At the same time, the crystal was given an abnormally high negative charge throughout its structure. As a result, the Earth's gravity would repel it with considerable force. Conceivably, this force could be as much as about 1000 G's. The crystal originally weighed one ounce and the gravitational force would enable it to lift a 55 pound weight. More than likely, the weight itself was also impregnated with a high concentration of very soft electrons which, when disintegrating, would give it a gravity nullifying, negative charge.

The impregnation with hard electrons would tend to produce high temperatures. Undoubtedly, Howsky and Groot found this to be the case. Therefore, in order to prevent overheating, the parts involved had to be subjected to low temperatures. Attempts to explain the results of the experiment, as expected, were pitifully vague and inept. The reader can see that all aspects of these results were in perfect harmony with concepts already presented.

Experiments involving similar principles, which were promoted by the *Chicago College on Gravity Research*, show that a 60 cycle alternating current, imposed on a solenoid, will cause an aluminum plate to levitate nearly a foot when placed over the solenoid. It is

significant and expected that the plate was heated during the process. A solenoid subjected to AC will radiate very low frequency and unstable photons and soft electrons. They will, of course, penetrate an aluminum plate and disintegrate, releasing a high concentration of hard electrons in the material. Naturally, it would tend to levitate and heat at the same time.

## **THE PYRAMID POWER PHENOMENON**

Pyramid experiments are gaining wide publicity. So much has been written on the subject that little space will be devoted herein describing the effects produced. Perishables placed inside a pyramid generally show little, if any, tendency to decay or spoil. The energies experienced are extremely beneficial to humans, and prolonged stays over extended periods of time have resulted in some degree of rejuvenation. More about the pyramid's effect upon humans will be discussed in Chapter 32. In many instances, plant growth has been accelerated, and so on. It is not surprising that satisfactory explanations have not come to light. Physicists steeped in orthodoxy have remained silent. The mystery vanishes in light of the new insights already presented.

Soft particle bombardments from outer space, and especially from the Sun, concentrate inside the pyramid. Some, passing through the surface of the pyramid, are slowed down to such an extent that the Earth's gravitational field, repelling the negative charges, tends to keep them inside until collisions from other particles drive them out. Most of the particles collected by the pyramid concentrate along the edges. This is to be expected. Electricity on any charged body tends to do much the same thing with concentration at points and along edges. In fact, pyramid frames have been found to be nearly as effective as the closed pyramid if, and only if, there is a continuity in the framework or no breaks in any of the joining parts. This is also to be expected, since a break in the framework is similar to an open circuit. Figure 21 depicts the pyramid phenomenon.

The soft electrons collected on a pyramid frame or closed pyramid soon reach a saturation point, and continuous bombardment causes the excess to drop down inside the pyramid. This, coupled with the gravity repelling forces, results in a high concentration inside.

Soft electrons ejected from apex by Earth's gravity by funnel effect

Soft electrons radiated from the sun and outer space encountering the pyramid.

When edges becomes saturated, excess particles are forced inside the pyramid

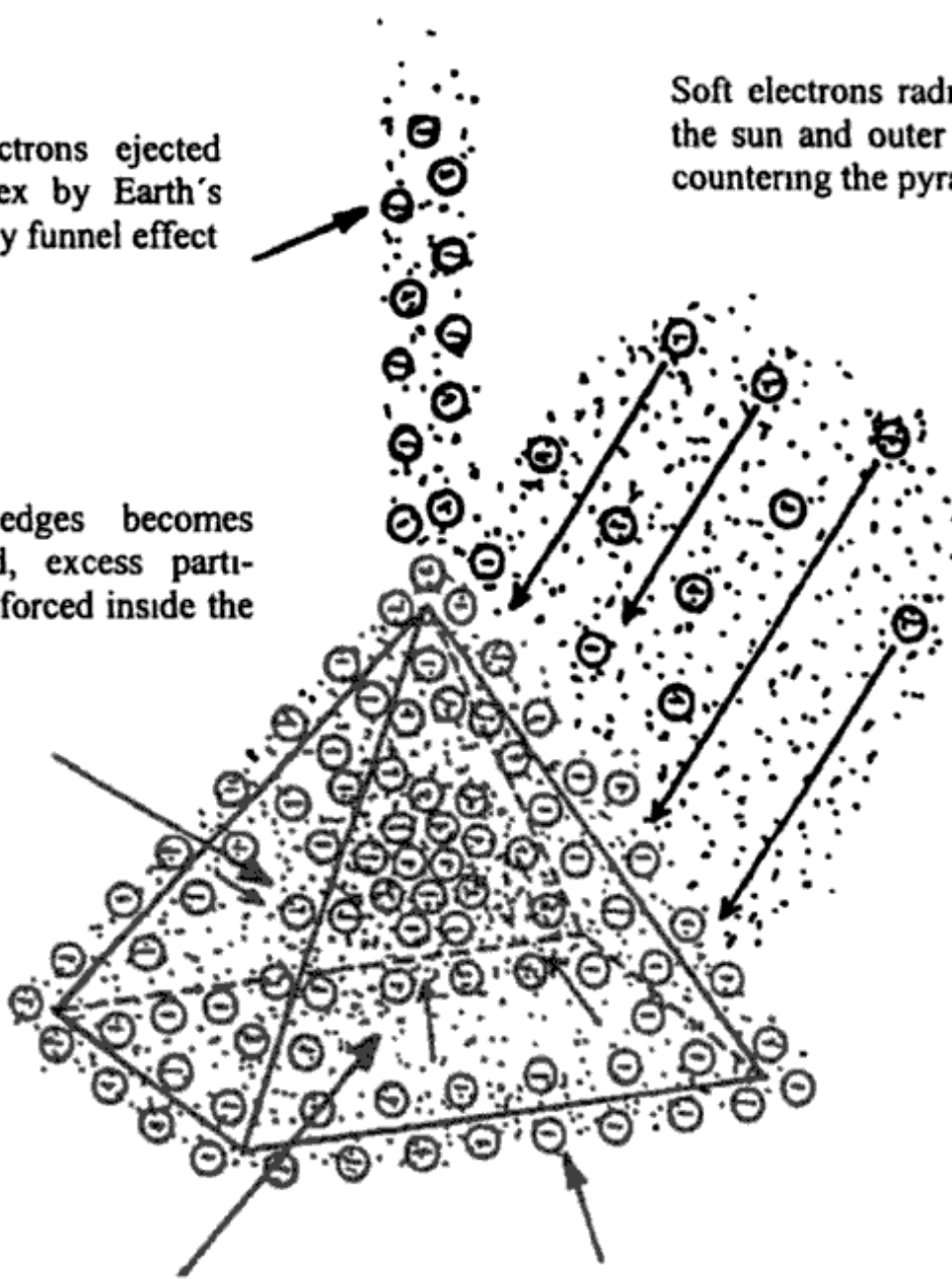

Earth's gravity tends to repel negative charges. This helps to maintain a high concentration of soft electrons inside the pyramid.

Soft electrons are captured along the edges of pyramid in a manner observed with ordinary electrical phenomena.

*FIG. 21: THE PYRAMID PHENOMENA*

The proportions of the pyramid are apparently a factor in its performance. If the sides are too steep, many of the soft electrons will move along the edges into the ground outside, instead of being forced inside the pyramid. If the slope is gradual, the angles are too obtuse to



allow many particles to collect. Also, the particles will tend to strike the surface at nearly a right angle and pass straight through, with only a small reduction in velocity. If they strike at a sharper angle, there is a greater tendency for them to be retained by the material.

If the two sides of the base of a four-sided pyramid are aligned with magnetic north, it is allegedly more effective. Since particles tend to travel down magnetic lines of force, the flow of soft particles inside the pyramid is directed more towards a side than an edge. This reduces the tendency of the particles along the edges to be dislodged before sufficient quantity accumulates. At the same time, particles attached to the sides tend to be forced to the edges, allowing a greater charge to build up.

If a razor blade is placed with its edges pointed in the direction of the Earth's magnetic field, a slow honing action occurs along the edge. The soft particles affect the cohesive forces of the molecules of the blade, and render it more plastic for a short distance below the surface. The constant flow redistributes the molecules which will be more affected at the thinner part of the blade. The blade, being metallic, will also attract and concentrate soft electrons along its surface. It has also been found that this honing action can even take place outside a pyramid, but at a much slower rate.

Although when ordinary materials are used, frame pyramids are nearly as effective as those with sides. Pyramids can be rendered more potent by lining the interiors of a non-metallic enclosed pyramid with metal foil such as aluminum or copper. The foil allows a greater quantity of soft electrons to accumulate around the non-metallic outer portion because the soft particles do not pass through the metallic substance as easily. This causes a backup of soft particles. During the process, the foil absorbs large quantities of soft particles, before many of them can enter the pyramid. Pyramids also radiate soft electrons upward from the peak. Many of the soft particles that are momentarily stopped on the outside of the pyramid are repelled upward by the Earth's gravitational field, and also by soft electrons attached to the pyramid. A funnel effect is the result with the ejection of soft electrons from the apex. The Earth's gravity accelerates soft particles at a far greater rate than it does ordinary matter. Soft particles are associated with ethers much closer to those of the gravity-inducing particles than is the case with ordinary matter. After the pyramid becomes saturated, a greater quantity of soft particles than ever will concentrate inside. The foil will continue to radiate a high concentration of soft particles

during the night when the number of particles bombarding the pyramid is considerably reduced.

It is found pyramids work better during the summer than any other time of the year. They are also more effective in the lower latitudes, than similar ones located in the higher latitudes. This is because most of the energy concentrated by the pyramid comes from the Sun. There are conflicting opinions as to the effectiveness of pyramids because of this, since there is little understanding of the principles involved. For example, those who experiment with pyramids in Canada may claim they don't work, while those in Southern California will contradict them. Hyper-sensitive people have found the energy around a permanent magnet has the same "feel" as that inside a pyramid. This is understandable since they are both concentrating the same kind of energies.

A pyramid does not increase the flow of soft particles through the area covered by the pyramid since the same concentration flows outside the area. What a pyramid (and also an orgone accumulator to be discussed later) does is impede the general flow of soft particles and produces a back-up of particles inside and below the pyramid and consequently, a higher concentration of soft electrons in these regions. The material used in a pyramid is of great importance. This was demonstrated recently when a wealthy man in the Midwest built a pyramid-shaped house five stories high, which was then covered with gold-plated iron. The phenomena produced were completely unprecedented. For example, ground water was forced to the surface and flooded the first floor. The orgone or soft particle concentration inside and below the pyramid was so great and extensive, ground water was impregnated with such an abnormal concentration of negative charges it was repelled upward by the Earth's gravity.

Gold atoms have extremely high positive electrostatic field effects that are more extensive than that of any other atom. This is why gold is the most malleable of all substances. This means that soft electrons will have a greater affinity for gold than for any other metal. As a result, abnormally high concentrations of soft electrons will concentrate around gold. This effect is greatly enhanced when gold is in contact with iron. The dissimilar metals produce an EMF which, in turn, causes a flow of electricity or eddy currents resulting in the iron being magnetized. The magnetic field produced captures additional soft electrons. A higher concentration of soft electrons is created by this combination than could be produced by a similar thickness of gold

foil alone. It follows that by far the most effective material that could be used for pyramids or for orgone accumulators is gold-plated sheet iron. (Galvanized iron should not be used). It is not difficult to see how the condition would greatly impede the flow of soft particles through the pyramid with a consequent increase in concentration inside and below the pyramid. The Earth's gravity plays an important role in the process by its tendency to repel soft electrons upward. In fact, it is responsible for the radiation of soft particles from the apex of an upright pyramid. Soft particles that are nearly brought to a halt inside the pyramid and those sticking to the edges are repelled and funneled upward through the apex by gravity, as well as being repelled by other negative charges which are not dislodged by this force. When a pyramid is held upside down the radiation through the apex is still pronounced. Incoming particles are funneled and concentrated at the apex which are then forced outward by the incoming particles.

What has not been mentioned before concerning pyramids is the role size plays in its performance. With everything else being the same, the greater the size, the better the performance. (This is also the case with orgone accumulators, to be discussed later). The reason is almost self-evident. The thicker the layer of concentrated soft electrons incoming soft particles must pass through, the more they are slowed down in passing through this concentration. This results in a greater back-up of soft electrons and an increase in the concentration. A large pyramid offers a greater thickness of concentrated soft electrons in its interior than a smaller one. (The manner in which pyramids and accumulators concentrate soft electrons will be given in more detail in Chapter 18)

Another reason the larger pyramid and accumulator are more effective than the smaller ones (and of equal importance) is the ratio between volume and surface area. Soft electrons are continuously bleeding from the surface of pyramids and accumulators. Since the surface area of the larger ones is much smaller in proportion to volume than is the case with the smaller pyramids and accumulators, a much lower percentage of the soft electron content of the larger ones is lost. This results in a greater build-up of orgone concentrations. Consequently very small pyramids and accumulators are ineffective.

## THE GREAT WORK OF VIKTOR SCHAUBERGER

The groundwork has been laid for the proper understanding of the researches of the great naturalist, Viktor Schauberger (1885-1958). While a forester in the mountains of Austria after World War I he observed many phenomena that completely violated the accepted laws of conventional physics. For example, he was puzzled by the fact large mountain trout could stand motionless for an unlimited period in the most violent mountain streams but when disturbed they escaped with fantastic speed against the stream and never with the stream. He also wondered why they could levitate up high waterfalls, then shoot up in the air and land several yards further upstream.

Another puzzling phenomenon he noticed was the behavior of rocks at the bottom of a pond two meters deep in a mountain stream. Some of them which were egg-shaped and the size of a man's head were moving around and colliding with each other. Finally they started moving in circles toward the surface in dancing movements where they swam around. The ones which remained on the bottom without moving had rugged and angular forms.

Schauberger also noticed that water flowing in a stream becomes purified and charged up by a vortex motion as it swirls around rocks and boulders. He also noted a drop in temperature after passing over these obstacles. By applying this knowledge, he achieved awesome results in cleaning up polluted environments of the time. Despite all of this his achievements have been ignored. This has been the basis of a more recent invention which transforms ordinary tap water into a water that is wetter (a lower surface tension) with a considerably improved taste. It is also softer. In Australia, farmers who experience serious hard pan soil problems have reported that this conditioned water breaks away the bonding agent from the mineral leaving the soil soft and pliable within two weeks of installing one of these units. This device called the "Care Tree" water conditioner consists of only a piece of glass pipe with a specially designed core of 16 metal alloy forms shaped to create the effect Schauberger observed when water is forced through it. Attached between the water meter and one's home all of the water used has been treated. All of the impurities and chemicals previously in the water are removed without fouling the device. It has never been adequately explained as to what happened to it. The accepted explanation is the unwanted particles are somehow

suspended and can never again cling to the water molecules or the sides of the pipe.

Previously Schauberger developed a similar device for water purification. It consisted of a spiral-wrenched copper pipe shaped like the kudu horns of an antelope. Water passes through this at a high velocity. The water from this was not only free of contaminants but had a better biological effect on living organisms. The spiraling water was counter clockwise (following the left hand rule). Interestingly enough if the water flow followed the right hand rule it did not produce this effect. It was also noted that a straight pipe of glass offered more resistance to the flow of water than did a straight copper pipe. With a spiral-wrenched copper pipe the friction decreased still more and at a high velocity suddenly became negative. A similar principle is involved with fish remaining motionless in a raging mountain stream. The spiraling motion also produces a temperature fall of a few centigrades in the water. Also in a dark room a weak corona is seen around the tube. Schauberger applied these principles in the building of an implosion motor which produced an electrical output energy which was 9 times the input energy necessary for rotating the device.

Another type of experiment that demonstrates the principle outlined in this chapter is as follows: A pressure of 73 p.s.i. forced tap water through a pipe. The jet at the bottom of the pipe had a diameter of about 2.5 mm. (The higher the pressure the better the results). About 30-40 cm beneath the jet a metal container insulated on the outside with paraffin (overlapping the top edge) was placed; it is important to have the container isolated from the ground. A wire led from the container to an electroscope.

When a paraffin plate was held in an angle a short distance from the thin water thread, the electroscope registered a charge of 10,000 volts! Connecting the wire to a neon tube would make it glow. Later this experiment was extended by using a second jet at a distance of 60 cm from the first. The result was a double charge. This was accomplished by crossing isolated conduction from one water thread to the container of the other and vice versa. The loop through which the water thread goes must be horizontal and of a certain height. As soon as the static electric field reached a certain density, the water thread beneath the loop split and each single thread of water reversed its course and rose upward (even with 73 p.s.i. behind it) and danced around in the air.



The above phenomena are not only thoroughly accounted for by the concepts already introduced but provide a marvelous confirmation of the validity of this new science. First consider the fish in a raging mountain stream. The water is highly agitated and thus gives up large quantities of hard and soft electrons of varying degrees of hardness to the fish. The skin and outer scales are given a high negative charge which tends to repel the outer electrons of the water molecules. This totally eliminates drag and since this effect covers the entire fish the net forces exerted on the fish by the flow of water is practically zero. This effect is even more enhanced if the fish moves upstream, far more so in fact than if moved with the current. The reason the fish is able to levitate up the falls now becomes almost self-evident. At the bottom of the falls, the water is far more agitated than at any other place. Therefore, a much higher concentration of hard and soft electrons are given up by the water and absorbed by the fish. Thus the entire body acquires an overall negative charge which is then repelled upward by the Earth's gravity.

The answer to the total elimination of aerodynamic drag becomes apparent. If the entire surface of a body is given an adequate negative charge consisting of the right combinations of hard and soft electrons it will experience no drag moving through the atmosphere at any velocity. UFOs continually demonstrate this principle by moving through the atmosphere at any velocity without heating up and with no sound effect.

The floating rocks Schauberger noticed was merely a case of the rocks acquiring a sufficiently high negative charge to levitate to the surface. The rocks with the rugged and angular forms didn't acquire as high a charge as the rounded ones because charges tend to concentrate around points and edges. This lessens the amount of charge accumulated in the main mass.

The explanation of purification and the charging of water swirling around rocks and boulders also becomes clear. The softer and more unstable soft electrons given up and disintegrated by the turbulence eliminate the impurities by two different processes, transmutations and dematerialization. A portion of the soft electrons enter the nuclei of the atoms comprising the impurities changing the nuclear structures by depositing hard electrons. This effects a transmutation. The transmutation process is explained in more detail in a later chapter. The atoms and molecules that are not transmuted are dematerialized by the proper concentration of soft particles comprised of light

photons of the right frequencies. (The dematerialization process is also analyzed in a later chapter). As a consequence the impurities either vanish by dematerialization or are converted into an inert and harmless substance that does not precipitate.

The charges in the water are released by the softer and more unstable soft electrons disintegrating and releasing harder and more beneficial soft electrons. It should be noted that water contains an extremely wide variety of soft particles. The lower water temperature results from the more unstable soft electrons having been removed from the water leaving the more stable brand. This means fewer disintegrations with the consequent release of fewer hard electrons that produce thermal agitation.

Incidentally the "Care Tree" water conditioner mentioned above was effective only when the water passed through it at a high velocity.

The reason a glass pipe offered greater resistance to the flow of water than a copper pipe is that the glass surface had a lower negative charge than the copper. The copper being more positive had a tendency to collect a higher negative charge at the surface. The spiral tube produced a greater turbulence in the water causing it to give up more hard and soft electrons to the copper surface. The corona seen around the tube was the result of a very high concentration of soft electrons inducing many of them to disintegrate into their constituent light.

The spiraling flow of water following the right hand rule (clockwise) was not effective because the normal flow of negative charges follows the left hand rule. All known space is permeated by soft electrons of all kinds. When the vortex flow is counter clockwise the surrounding sea of soft electrons move in to fill temporary voids created by the water flows. In other words an entrainment takes place. This involved the Coanda effect and what the author has always called the cloud-buster effect to be explained in more detail later. This incoming flow of soft electrons of course is a vortex moving counterclockwise. When the flow of water is clockwise cancellation effects take place with the soft particle flows. It should be kept in mind that the surrounding soft electrons keep the soft particle concentration in the water at a high level. Without it the water loses much of its properties.

By now the explanation of the effect produced by water forced through the tubes with an I.D. of 25 mm at the bottom at a pressure of 73 p.s.i. becomes self-evident and needs no further explanation. It

merely demonstrates that water can easily be made to give up huge quantities of negative charges.

Only a portion of Schauberger's achievements have been outlined. He certainly ranks as one of the greatest scientists and naturalists of his age and far above many who have received much greater acclaim.

These properties of water in conjunction with the Coanda effect can be utilized in the building of a revolutionary self-sustaining electric generator that is the ultimate in simplicity and performance. This has been covered in Chapter 21.

## **BROWN'S GAS**

(If this were not a scientific treatise the above title could have misleading implications)

Another puzzling phenomenon concerning water is a substance known as Brown's Gas. It was developed by a research professor Yull Brown. This amazing substance is gaining world-wide applications. Supposedly he had found a way to separate hydrogen and oxygen from water yet at the same time form a non-explosive mixture that can be stored under pressure. It can be used for a wide variety of welding purposes. The Brown's Gas flame can sublime tungsten at a temperature of nearly 6000° C and steel can be welded to brick. It can also be used with lower temperature requirements.

This gas can also be used for nuclear radiation dilution and clean-up. It has reduced this radiation by as much as 96%. Perhaps the most amazing property of this gas is yet to be mentioned. In the production of this gas one unit of water produces about 1867 units of Brown's Gas. When the volume of gas is ignited using a spark, a low decibel ping is heard and the entire volume is immediately converted back to one unit of water!

As will now be shown the properties of Brown's Gas are a confirmation of principles elaborated in this treatise. As indicated there the water molecule has vast havens for soft electrons in addition to those already present in water. Brown did not separate water into hydrogen and oxygen, he merely added additional soft electrons to the water molecules. These additional electric charges greatly weakened the cohesive forces between the molecules, converting the water to an unstable gas. All of the properties of Brown's Gas naturally follow.

Under welding conditions the vast concentrations of soft electrons supply the release of sufficient quantities of hard electrons to produce the needed heat. In addition the soft electron concentrations would enable iron atoms to partially interpenetrate brick molecules to produce a bond of brick and iron. With the ultra-high concentration of soft electrons the gas could readily neutralize the positive charges of nuclear radiation. The spark introduced to a volume of the gas would produce a chain reaction with the escape of all the excess soft electrons used to produce the gas thus breaking the weak bonds between the water molecules and the excess soft electrons they harbor.

# CHAPTER 15

## THE NEW COSMOLOGY

### THE SOURCE OF THE SUN'S RADIANT ENERGY, AND THE CAUSE OF NOVAS AND SUNSPOTS

One thing that all suns seem to have in common is their great size in comparison to planets. The astrophysicists speak of white dwarfs of planetary size and less. It is apparent from the evidence that has been presented throughout this treatise that any claims made by astronomers or astrophysicists pertaining to celestial determinations have about the same degree of merit as the other scientific claims that have been mentioned previously. There is nothing to justify the existence of a white dwarf. For one thing, due to its allegedly small size and its limited gravitational influence, it could only hold very small bodies of asteroid-size in orbits, and then only for a short distance away. According to the fallacious theories of orthodox science, a white dwarf consists of atoms with practically all their electrons stripped away, and hence possesses enormous gravity. It will be shown that astrophysicists have no way of accurately determining the distance or the size of any celestial body.

The larger the body, the greater its mass or volume in proportion to its surface area. This means that as the size increases, it is less probable that the energies produced by the normal activity of the atoms in the body's interior will escape from the surface, without a resultant increase in the temperature at its surface. The energy radiated from the surface will be in the form of photons and other particles of all types. Below a critical size, the surface area is sufficient to allow all of the radiant energy created in its interior to escape without an increase in temperature. In fact, such a body will lose heat unless it receives sufficient energy from its surroundings.



As a body increases in size, its surface area becomes increasingly inadequate to allow the radiated energy in its interior to escape without a build-up of heat at and below the surface. The surface will not radiate the heat or energy outward as quickly as it is created in the interior. The rate at which energy is radiated from a surface increases rapidly with a resultant increase in surface temperature. This varies as the fourth power of its absolute temperature. For example, within a certain temperature range, if the temperature is doubled, the rate at which energy in the form of photons and soft particles is radiated increases by a factor of 16.

The critical size of such a body will depend on its composition. For example, if it contains a high concentration of mildly radioactive substances, this critical size will be less. If the body has a hollow condition, the outside dimensions would have to be greater. The red giants, if they are even close to the dimensions claimed, would have to be hollow with relatively thin shells; otherwise, they wouldn't be red. Their surface temperatures would be astronomical.

The actual source of the energy that is finally radiated into outer space is the soft particles and photons normally radiated by the atoms of the material inside a sun; this is due to the activities of the fundamental particles. Because of the great mass of the sun, an abnormal concentration of these soft particles is always present in the interior. This concentration is greatest near the surface. There is a steady increase in intensity from the center toward the outside. This results in a continuous disintegration of a high percentage of those particles near the surface which is accompanied by a great increase in temperature, which in turn, results in a greater rate of disintegration with the release of harder particles which produce the higher temperatures. At the same time, the rate at which the soft particles are created increases. A state of near equilibrium exists when the rate at which the soft particles are created in the interior approximately equals the rate at which they disintegrate. It would follow, then, that the highest temperatures exist at the surface and steadily decrease with the distance below the surface. This means that any sun has a relatively cool interior!

The principle that size is the major factor in a celestial body's ability to radiate is confirmed by the behavior of very large planets such as Jupiter and Saturn. An application of this principle indicates that bodies of such size should start radiating more energy than they receive from outside sources. Recent determinations indicate that both

Jupiter and Saturn do, in fact, radiate more energy than they seem to receive from the Sun. A recent probe showed a surprisingly higher temperature in Jupiter's upper atmosphere than was formerly believed to exist.

It now becomes apparent that the conventional theory which states that the radiant energy of the Sun is produced by thermonuclear reactions is complete nonsense. One thing to consider is that if this were the case, the Sun's radiation would be so lethal that no life could exist on any of the planets in the solar system. The deadly and highly radioactive radiations resulting from this kind of reaction would be simply too much for nature to cope with on a daily basis. The high concentrations of ultra-violet rays are potent enough, but this has been mitigated by the atmosphere and the law of redistribution of energy.

Although the interior of the Sun is relatively cool, the temperature gradually builds up over eons of time. The effects of the disintegration and dispersion of soft particles generated by the activity of the fundamental particles, slowly increase the temperature throughout the interior. Much of this effect is contributed by less stable particles that don't travel very far from their point of origin before disintegration occurs. As the temperature increases, the rate of disintegration of particles increases. This greater activity also results in more particles being created. The more stable particles concentrate near the surface because they travel further before disintegration. When this concentration reaches a critical state, an explosion results, causing an abnormal quantity to be ejected from the surface. This is the cause of the sunspots which function as relief valves. This condition has its parallel on Earth in the form of volcanoes.

Occasionally throughout the universe this heat build-up in stars is much greater than normal due to a combination of factors which might include an increase in the quantity of radioactive elements in the interior caused by transmutation. In such cases, relief valves in the form of sunspots no longer take care of the excess energy increases and large portions blow apart, releasing astronomical quantities of radiation. After the explosion, the supernova becomes a burned out body in comparison to its former state. Considering the countless billions of stars within our vision, and that only a few supernovas have been observed down through history, it is logical to conclude that it is not the fate of the great majority of stars.

One of the phenomena concerning the Sun, which completely baffles all of the scientists, is that it seems to rotate faster at the

equator than it does in the higher latitudes. The sunspots in the vicinity of the equator make a revolution about the Sun in less time than those in the higher latitudes. This is an annoying paradox which can't be pushed aside by these scientists because it is out there for all to observe.

The part of the Sun that we see is a highly fluidic blanket. The portion around the equator could rotate faster if, and only if, a steady external pull is exerted on this region of the Sun. Otherwise, internal friction would eventually produce a uniform motion. This means that bodies in orbit near the equator and close to the surface are generating a high concentration of gravity-inducing radiations. It becomes evident that such bodies could not consist of normal matter. If they are not a group of UFOs, or special satellites comprised of unique materials, then they must be composed of atoms and molecules made up of softer particles which are affected very little by the Sun's radiation. Such bodies could generate a concentration of gravity radiations considerably out of proportion to their masses. Being constructed of this kind of material, they would be practically invisible.

## **ASTRONOMICAL ERRORS IN DETERMINING PLANETARY SIZES AND DISTANCES**

Charles Fort cited many instances of fiascos that belied the astronomers' claims of extreme accuracies in determining stellar and astronomical distances. In the process, his revelation did little to enhance their reputations as paragons of integrity. He also presented evidence indicating that the stars and planets are much closer than is commonly believed. The following discussion will show that Fort was right in many respects except for the planets being closer and the source of error in astronomical determinations will be analyzed.

The principles employed by astronomers in their measurements are essentially the same as those used by surveyors in measuring elevations and distances. Some of the surveyors' instruments are scarcely less sophisticated than those of the astronomers. Yet, according to Fort, some of the experts admit that they are unable to determine the height of mountains with any degree of precision, and, in fact, their calculations can be off by as much as ten percent. This is

reflected in the inconsistent heights attributed to various mountains over periods of time. There are significant fluctuations. Different surveys give different results. The author recently had an opportunity to check the above with an altimeter. It was adjusted for sea level, and then a trip was made which finally culminated in a drive to the top of a lookout mountain, which is supposed to have an elevation of 9,269 feet. It rises abruptly out of a plain that has an elevation of about 4,300 feet. The altimeter agreed very closely with established elevations along the way such as those of towns with elevations varying from 1,000 feet to over 4,000 feet. At the top of the mountain, however, the altimeter registered only 8,800 feet. The author then readjusted the altimeter to register the 9,269 feet, which was the height attributed to that mountain, and returned. At every spot on the return trip, the altimeter consistently indicated elevations more than 400 feet higher than before. Even after several months, the altimeter still showed an elevation more than 400 feet higher than it should. It is significant to note that all phases of the trip took place during fair weather, and therefore fluctuations in barometric pressure were kept to a minimum. Later a similar check was made with a better altimeter. This time it indicated a height of 8,900 feet for this mountain. A similar check was made on another mountain with a given elevation of 4,078 feet. It rose about 3,500 feet above the surrounding country, at the top the altimeter registered 3,750 feet; yet it agreed with other established elevations much lower.

The fact that the altimeter was accurate at all places except at the top of the mountain whose height was found by triangulation, shows that the methods employed by surveyors and astronomers are far from being accurate. The altimeter showed that there was an error of about ten percent in the measurement of the height of the mountain above its base. If surveyors with their fine instruments cannot determine the height of a mountain only a few miles distant, one can only marvel at the discrepancies that would occur when one is observing an object at planetary or stellar distances.

The height of mountains determined by triangulation will always be considerably more than the true value. There are two factors involved. First, the atmosphere becomes steadily denser as one descends from the top of the mountain to the base. Also, the orgone concentration becomes greater closer to the ground. This means that light rays from a mountain top will be refracted toward ground level and will appear to an observer at ground level to be originating from a point well

above the top of the mountain. This has been confirmed by the author as mentioned earlier in this chapter. A more recent confirmation came from an expedition to the top of Mt. Everest. The barometric pressure at the top was nearly 250 millimeters of mercury, whereas the predicted pressure was 235 according to the surveyed value. This shows that the elevation of Mt. Everest is only about 27,500 feet instead of the 29,000 plus attributed to it. The scientific community came to the rescue with another of their absurd explanations. The following is a quote from the Feb. 1986 issue of *Science Digest*: *The reason for the higher reading on Mt. Everest is that from 13,000 to 52,000 feet above sea level barometric pressure fluctuates with latitude. This is due to a large, cold mass of air in the stratosphere above the equator that squashes the air below. At latitude 28 degrees north, Everest climbers enjoy more oxygen than they would on mountains farther to its north.* This inane explanation violates all the rules governing the properties of a gas. How this mass of air could squash the air at selected elevations and not affect the air at lower elevations has not been made clear. Also why would such a cold air mass exist near the equator where it would receive more heat from the Sun than air in the higher latitudes? What about the mountain the author mentioned above which is located at about 42° 30' north latitude? For similar reasons given above, topographic maps made from aerial surveys will show the same errors. For example, the author recently found that a railroad on a topographic map is actually hundreds of yards farther north of a certain highway than the map indicated. Recently, an acquaintance of the author had his property surveyed to determine the acreage. After it was finished, he checked with a tape measure some of the distances determined by triangulation and found significant errors. It is indeed incredible that after well over a century of mapping by the standard surveying methods, refraction effects of light have seemingly never been taken into consideration. The bulk of the refraction effects are due to orgone concentrations. Surveying methods give accurate elevations for plateaus and large areas because all measurements are taken close to the ground where refraction effects are kept to a minimum. Variations in the measurement of mountain elevations taken at different times are due to fluctuations in orgone concentrations, they are higher on hot sunny days than on cloudy cool days. Also they are generally higher during summer months than during spring, winter or fall months.



The above examples showing the unreliability of results obtained by triangulation is obviously only a tip of the iceberg, so to speak. The reader can only marvel at additional factors astronomers are faced with when they apply triangulation. Consider the Van Allen Radiation Belt, varying concentrations of orgone throughout space, etc. and then wonder how astronomers have the temerity to claim they can determine planetary and stellar distances with great precision.

There are several factors which astrophysicists and astronomers have not taken into consideration in their calculations. Perhaps the most important of these is the fact that all electromagnetic radiations, including gravity in free space, suffer an attenuation affect, well above that due to the inverse square law. It has already been shown that all space occupied by the material universe is permeated with soft and hard particles of all kinds, that have been radiated by planetary systems for countless ages. This principle is demonstrated by fluctuations in the velocity of light to be discussed soon and the gravity attenuation that prevents the roofs of giant caverns deep inside the Earth from caving in. It also follows that there is a steady decline in the velocity of light as it travels through space. The reasons become apparent from the following considerations.

Normal light, or light which has traveled relatively short distances from its source, immediately resumes its original velocity, after passing through a dense medium, such as glass or water. As shown earlier, this is due to the close bunching of photons and soft electrons in any given ray. The concentration of particles in a ray of light tends to decrease after traveling great distances. The farther it travels, the more attenuated the ray becomes. This means that its ability to increase its velocity after passing from a medium of a given density, to one less dense will be reduced. This of course, is due to the scattering and dissipation of particles within the ray, as it encounters the conglomeration of particles, moving in random directions throughout space.

Since conglomerations of soft particles permeate all known space, and the distribution is not uniform, it follows that light will experience refraction effects, even when passing through free space. Therefore, even under the best conditions with observations beyond the atmosphere, astronomical observations cannot be made with any degree of accuracy. The difficulty, of course, is compounded when they are made inside the atmosphere. It is a small wonder that Charles

Fort found a wealth of evidence that completely debunked the astronomers' claims of great precision.

The fluctuation in soft particle distribution and the refraction effects of the atmosphere rules out the possibility of averaging out errors by making many observations and applying the mathematical method of least squares, developed by the mathematician Gauss. Conventional statistical theory obliterates actual small variances and distorts data by such averaging out processes. The gross errors that crop up despite these methods speak for themselves.

In order to measure the orbital distance of the various planets, it was necessary to find the distance of the Earth from the Sun. Originally, this was allegedly found by measuring the angles that two widely separated observation points on the Earth made with the Sun. It is known as the parallax method. The distance to the Sun was calculated from these angles and distances between the points. The size of the Sun could then be determined and, knowing the orbital period of the Earth about the Sun, the Sun's mass and surface gravity were calculated, by applying the false Newtonian concept of gravitation.

More recently, the distance to the Sun known as the "astronomical unit" was supposedly determined with a high degree of "precision" by measuring the distance of the body Eros by the parallax method when it was closest to the Earth. Knowing the period of Eros' orbit, the distance to the Sun was calculated by the use of Kepler's law, which states that "the square of the periods of any two planets are proportional to the cubes of their mean distances from the Sun." Since the orbital periods of the planets are known with a reasonable accuracy, most of the other unknowns within the solar system could be calculated by knowledge of the Sun's alleged mass and surface gravity. By now, it should be apparent that it would be a miracle, or at least one of the strangest coincidences ever, if the actual distances coincided even approximately with the calculated values.

If the Newtonian concept were valid, and the planets were held in orbit by only the effects of the Sun's surface gravity, then the orbital periods of the planets would be a reliable means of determining planetary distances. Since it has been proven that the concepts on which these calculations were made are false, it can be safely concluded that the size of the orbits is considerably different from what the astronomers claim. As a result of dissipation effects of radiation, well beyond that which can be expected from the inverse

square law, it follows that planetary distances are very much different from the accepted values.

This excessive attenuation of the gravity effects of the Sun is reflected in the alleged rapid increase of orbital distances of the outer planets. For example, the Earth is one orbital unit from the Sun. Mars is supposed to be 1.52, the Asteroids 2.76, Jupiter 5.2, Saturn 9.58, Uranus 19.16 and Neptune 30.24. It is interesting to note the manner in which the orbital distances increase. From Earth to Mars the difference is .52 units. Mars to Asteroids 1.24, Asteroids to Jupiter 2.44, Jupiter to Saturn 4.38, Saturn to Uranus 9.68, Uranus to Neptune 11.08.

Planetary systems are a result of intelligent planning. This means that orbital distances will be kept to a minimum. The orbital differences will be great enough to prevent excessive perturbations when planets are in conjunction with each other. The larger the planet, the further removed it must be from adjacent orbits. Even with this taken into consideration, a big discrepancy in the alleged planetary distances becomes apparent. The outermost planets Uranus and Neptune have the greatest orbital difference, and they are not the largest planets.

It does not even follow that the longer the orbital period, the greater the planetary distance. For example, within certain limits, to be discussed shortly, the larger and more massive the planet beyond a certain critical amount, the slower it must move in order to stay in a given orbit. This is because the total gravity effects of the Sun are unable to permeate and affect the entire mass to the extent that they would a smaller planet. For example, a planet like Saturn could be placed in a stable orbit inside that of Earth. Yet, it would have to move so slowly in its orbit that its orbital period would be much greater than that of the Earth. This means that orbital periods are not a reliable gauge for relative orbital distances.

A satellite too small to transform the Sun's higher frequency radiations will depend only on the Sun's surface gravity to be held in orbit. This means that such a body would have a much lower orbital speed than that of the Earth in order to maintain an orbit comparable to that of the Earth. The situation is similar to that of a body of extreme mass.

An interesting question arises in regard to the Asteroid Belt. It supposedly consists of thousand of fragments, ranging from less than a mile in diameter to over 500 miles in diameter, in orbits between Mars

and Jupiter. Any object over thirty miles in diameter could transform a significant portion of the Sun's higher radiations into gravity effects. Astronomers have no way of measuring either distance or these objects or their sizes. Also, it is not likely that the orbital periods of more than just a few of the larger ones have been determined with any degree of accuracy. Therefore, in regard to the principles just introduced, the Asteroid Belt offers no paradox.

Another factor that would help resolve any paradox that might develop in regard to the outer planets is that there is overwhelming evidence our Sun is a binary, as most stars happen to be. The Earth-Moon system is in such an orbit that our visible Sun is always between us and its twin. The other planets in the solar system would then be exposed to the entire binary. Some of the more intelligent members of the scientific community have long suspected that our Sun is a binary. The other planets seem to be much brighter than they should be, on the assumption that our visible Sun is the only one in the solar system. Also, the solar prominences and outbursts seen during total eclipses seem much too violent to be coming from just the Sun we are aware of. Other strong evidence is the case of Mars. The great polar caps melt during the summer months and patches of green advance toward the equator. This shows vegetation. This means that the temperature in the polar regions gets well above the melting point at times. If our Sun were not a binary, the temperature on Mars based on accepted concepts would never rise above sub-zero temperatures at any time or place on its surface.

Assume that Mars is 1.3 times as far from the Sun as the Earth is. This is much closer than the distance claimed by the astronomers. This means that Mars would receive only  $1/1.3^2$ , or 59 percent of the heat from the Sun, than we do. The highest temperature recorded on the Earth is about 135° F or 64.3° C or 337.3° absolute. On this assumption, the temperature on Mars should never rise above .59 (337.3) degrees absolute or 199 degrees. This is 74 degrees Centigrade below freezing or -101.2° F! Even if Mars were only 1.2 times as far from the Sun as the Earth, its temperature at any place on the surface would never rise above -38° F! These calculations are based on the principle that the heat content of a body is directly proportional to its absolute temperature. A picture sent back from Mars on June 7, 1979 by Orbiter 1 shows a landscape covered with snow. The snow had obviously drifted in places which belied statements that we were only observing extremely thin coatings of ice on the rocks and soil. It was

admitted that a similar coating, one Martian year previous to this, was observed and it lasted 100 days. This had to have been taken during the late winter or early spring on that portion of Mars. It is extremely significant that it melted before the summer months. It is apparent from this that the temperatures on Mars are about the same as those on Earth. This can be accounted for if it were based on the conclusion that our Sun is a binary. Further evidence that Mars has a warm climate will now be given.

An incredible contradiction that appeared in an article on Mars was contributed to the 1978 edition of the *Encyclopedia Americana*. Articles on subjects of a scientific nature are not likely to be solicited by such publications unless the contributors have a high standing in the scientific community. Therefore, it is safe to conclude that the author of this article was such an individual. He stated that Mariner flights have shown that the north and south polar caps on Mars consist of very pure dry ice or frozen carbon dioxide at a temperature of  $-128^{\circ}\text{C}$  or  $-198.4^{\circ}\text{F}$ . Yet, further on, he also stated that the temperature at the South Pole may, on occasion, rise to  $32^{\circ}\text{F}$  ( $0^{\circ}\text{C}$ ), but that the average temperature is about  $20^{\circ}\text{F}$  ( $-7^{\circ}\text{C}$ ). The North Pole is supposed to be colder where the temperature may get down as low as  $-120^{\circ}\text{F}$ . From this information, it would appear that the polar regions of Mars experience about the same temperatures as the Earth's polar regions. Yet, they are supposed to turn vast areas and quantities of carbon dioxide into dry ice at  $-198.2^{\circ}\text{F}$ !

Where all this carbon dioxide could come from on a planet devoid of vegetation, with an atmosphere of about one percent of the density of ours, was not explained. If this author is not an academic scientist, then we are faced with a real paradox. He has demonstrated an ability for "doublethink" that one should expect only from an honored member of the scientific community.

According to NASA, recent calculations have shown that the Martian atmosphere has only about one percent the density of the Earth's. This contradicts other findings concerning cloud formations. Dense and very extensive clouds are often detected on Mars. Pictures of the volcano Olympus Mons have shown clouds hovering close to the summit of the mountain, which is supposed to rise 15 miles above the surrounding countryside. It is claimed that clouds are often found at an elevation of 90,000 feet! This is much higher than any water vapor and ice clouds found on Earth. The fact that they move shows that the air is sufficiently dense at such altitudes to produce winds



capable of moving clouds. This indicates that Mars actually has an atmosphere denser than that of the Earth at such elevations.

Another factor that confutes the claim of a thin atmosphere is the tremendous dust storms that often occur. Some of them dwarf any that have ever been experienced here on Earth. The experts try to surmount this difficulty by assuming wind velocities of over 300 miles per hour. How sustained wind velocities of this magnitude could be achieved has never been made clear. In addition, extensive areas of fine dust necessary to produce such a condition could not exist in an atmosphere as thin as that which has been attributed to Mars.

Another of the alleged findings of NASA that is open to question is the claim that the magnetic field of Mars is about the same as that of the Moon. Mars has a relatively high rotational velocity and, therefore, should have a strong field. There are two possible reasons for this discrepancy. First, it is likely a recent attempt to discredit the geomagnetic theory of planetary rotation which is in direct conflict with orthodox concepts and is gaining favor, or the weather conditions on Mars are such that the negative ion content in the atmosphere is often very low. It has been found that in many areas of persistent winds, the negative ion count is very low. The measurable field of a planet is dependent on the concentration of hard electrons in the atmosphere. The most likely explanation as shown later on is that the Martian atmosphere is permeated with very high concentrations of stable soft electrons. The magnetic fields they create would not register on a standard magnetometer. The integrity of NASA officialdom has consistently proven to be much less than impeccable.

Radar pictures recently taken of Venus show two almost perfectly round depressions that are antipodes of each other. One has a diameter that is 40 percent as great as that of the planet itself. The other has a diameter nearly 30 percent as great. Incredibly, these were explained away as being impact craters. It is difficult to believe that even the scientific community has any members of sufficient mental vacuity to endorse such an explanation. Yet, the author knows an honored member intimately (in fact an older brother) who insists this is what they are. As anyone who has even a modicum of intelligence should realize, an impact crater will have a depth that is a reasonable percentage of its diameter, especially if the missile does not bounce off or sink below the surface. An impact capable of producing a crater with such a diameter would completely shatter even a solid planet.

The impossible coincidence that a planet would have two such craters nearly the exact antipodes of each other has been cheerfully ignored.

The only possible explanation is that these "depressions" are giant openings into the hollow interior. The energies being radiated from these openings would deflect radar, to the extent of creating the illusion of them being shallow sinks. Venus, being closer to the Sun and in full view of the binary, would require much larger openings to dissipate the heat that would build up in the interior.

Other claims by NASA with regard to Venus which are steeped in contradictions, are those of the dense clouds surrounding Venus, consisting of sulfuric acid, and that the surface temperature is about 1000° F. Early pictures of Venusian terrain sent back by a probe which soft-landed on the surface, show a landscape very similar to that of the Earth or Moon. Rocks were shown with sharp edges and there was the usual evidence of normal ground erosion. The type of erosion that would be produced by a combination of high concentrations of sulfuric acid and 1000° F would reduce everything on the surface to a blob. The clouds on Venus, undoubtedly, consist of a tremendous mantle of water vapor and droplets which would protect the surface and promote earth-like conditions.

Evidently, NASA has been unable to get its act together properly. In addition to the above, some reports have indicated that the Martian polar caps are a mixture of dry ice and frozen water, while others give the impression that they are comprised only of common ice. Such inconsistencies on the part of NASA could be attributed to the fact that NASA officials consist of various kinds of liars. Apparently, few, if any, of them are clever enough to be consummate liars. If it were not for the "double and triple thinking" ability of academic scientists, the credibility of NASA might be seriously questioned by more individuals.

Another factor that leads astronomers astray is the fact that higher frequency light is refracted more by a lens than the lower frequencies. As a result, an image is magnified to a greater extent if the object is illuminated with higher frequency light. Light that is attenuated, in the manner described earlier, such as losing velocity, being scattered, and being brought to lower frequencies by the redistribution law, will have a tendency to be refracted less, the farther it travels. Each of these three factors is, by itself, sufficient to produce this effect. Together they compound it. Consequently, the image of a distant planet will not be magnified by a telescope, to the extent that the power would

indicate. As a consequence, the planet will seem to be more distant than it actually is.

The eye, which contains a lens, will play the same kind of trick and produce the same effect, but to a lesser extent, than with a telescope. A telescope then will only perform up to its expectations when closer objects are being observed.

Since electromagnetic radiations have a tendency to lose velocity after traveling great distances, it follows that the method of bouncing radar off planets is not reliable. This, including the determining of the Earth's velocity in its orbit by the alleged precise measuring of the aberration of light from stars, has supposedly enabled astronomers to calculate the astronomical unit to an extreme degree of precision. Allegedly, all of the various methods of determining this unit were in close agreement with each other. One can only speculate as to how much juggling of figures has taken place during the process in order to achieve such confirmation, since the integrity of the scientific community has proven to be less than admirable. All that can be said about all of these distances is that they differ from the accepted values.

Although planetary and stellar distances are completely unknown as far as astronomers are concerned, and there are no reliable means available (at least at the present time) of determining them, the diameters of some of the inner planets, including Jupiter and Saturn, can be calculated far more accurately than any of the other values in the realm of astronomy. The orbital distances of the planetary satellites in proportion to planetary diameters as well as their periods can be accurately determined. The determination of these constants are not affected to any significant degree by the dissipating factors of light mentioned above since a planet and its satellites are about the same distance from the Earth.

When a planet is viewed through a powerful telescope its diameter, and the relative distance of a satellite from its surface can be laid out along the scale. The main factor that renders it possible to approximate the diameter of any of these planets is the knowledge that they have practically the same surface gravity as the Earth.

If a satellite is very small as is the case with Mars' satellites, a planetary diameter can be calculated with a high degree of accuracy. In fact, Mars is the only planet in the solar system whose diameter can be reliably determined from the following relations:

$$\frac{v^2}{d} = \left(\frac{r}{d}\right)^2 g$$

$$\frac{2\pi d}{v} = t$$

Where  $d$  is the radius of the orbit in miles,  $r$  is the radius of the planet in miles. The diameter is  $2r$ ;  $g$  is the acceleration of Earth gravity in terms of miles per hour,  $t$  is the period of the orbit in hours, and  $v$  is the velocity in miles per hour. From the two known values,  $g$  and  $t$ , the others can be readily determined. The results are quite astonishing. Mars turns out to have a diameter of about 11,300 miles. Recent confirmations that the 11,300 mile calculated diameter for Mars is valid, has been unwittingly supplied by NASA. Measurements of surface detail by radar can be accurately determined. They show the diameter of the giant volcano, Olympus Mons is about 375 miles and the diameter of other giant volcanoes is in the vicinity of 400 km or 250 miles. Included in surface detail measurements is a great rift valley over 2,800 miles long. Radar pictures of the entire planet, including these prominent landmarks show that the diameter of Mars is indeed over 11,000 miles. Perhaps, the most accurate yardstick is the great rift valley whose length is slightly less than  $\frac{1}{4}$  the diameter of the planet! A radar picture of Mars, including this rift valley and one of the 250-mile diameter volcanoes appeared in the January 1985 issue of *National Geographic*. This 11,000 mile diameter is a far cry from the 4,200 mile diameter the astronomers claim. It also provides a dramatic proof by the domino effect, the validity of nearly all the concepts introduced thus far in this treatise.

The great disparity between the surface gravity effects of one large body of planetary size on another and its total gravity effects make it impossible to determine the size of the other planets in this system with any degree of accuracy by the above method. It has already been shown the total gravitational influence of the Sun on the Earth is about 50 times as great as that due to its surface gravity alone. There is another approach for determining these values that would be frowned on by the narrow and ossified minds of the scientific community. This approach is similar to the one used by the great Reichenbach to be discussed in Part IV by which he made many of his great discoveries.

The method used by the author in helping to find these values is known as dowsing. In the hands of one highly adept in this art, it has proven to be an extremely accurate and often reliable tool. It is analyzed and discussed in Part IV.

The author was fortunate to engage the services of one of the best in this field. He is a mineral processor and dowses out the chemicals he needs for any process with uncanny accuracy. He has had little formal academic training, which made him ideal for this project since he had no preconceived notions to influence his results. Planetary sizes and distances, including the astronomical unit (the distance to the Sun) had no meaning to him. Inaccuracies in his findings would have resulted in contradictions in some of his answers to the type of questions put to him by the author. As a test question, the author asked for the diameter of Mars. He determined this value to be between 11,000 and 11,500 miles! This was highly encouraging and convinced the author he was on the right track toward uncovering facts about the solar system that cannot be determined by conventional methods!

The author had already come to the conclusion the Sun must be much larger than is claimed in order for it to radiate as it does. This master dowser found its diameter to be over 2,500,000 miles. Once again, he was put to the test when the author asked for the Earth's average distance from the Sun. He found it to be about 277,000,000 miles. This coincides almost exactly with the established diameter. If the Sun is 2,500,000 miles in diameter, it would have to be this far away in order for it to have its apparent diameter. The attenuation effects of light cause distant objects to appear slightly further away than they are, does not apply to the Sun at this distance to as high a degree as is the case with planets. This is due to the ultra-high intensity of the Sun's radiation and the wide range of frequencies emanating from its surface.

The well-established 11,000 plus mile diameter of Mars by radar mapping also provides a fine confirmation of the validity of the 2,500,000-mile diameter of the Sun. By observing the retrograde motion of Mars, the ratio between the orbital diameters of Mars and the Earth can be determined with reasonable degree of accuracy because of the size of the retrograde angle. Since the true diameter of Mars has been found, its distance from the Earth can be readily calculated. It immediately follows that the distance of the Earth from the Sun is indeed about 277,000,000 miles, which shows the Sun is about 2,500,000 miles in diameter.

The next set of questions involved the Moon. From the principles established earlier, it follows that much of the Earth's gravitational influences on the Moon is not a result of its surface gravity. Much of the infra-red and especially that in the lower fringes radiated by the



Earth, are converted into gravity radiations as they penetrate the Moon. This means that the Moon must be much further away than the astronomers claim and, consequently, much larger! The dowser maintained his consistency when he determined the diameter at 5,200 miles and its average distance at 578,000 miles. This distance is as it should be if the diameter is 5,200 miles. However, this is in direct conflict with strong evidence indicating otherwise. For example, the umbra of the Earth's shadow on the Moon during lunar eclipse at the distance of the Moon is much larger than the Moon. In fact, this diameter as determined from the curvature of the shadow cast on the Moon, has allegedly been found to be 2.17 times the diameter of the Moon. This conforms with the claimed 2,160-mile diameter and 240,000 mile distance. There are significant facts cheerfully ignored by astronomers which detract from such a nice confirmation. Different eclipses show considerable variations in the curvature of the umbra. In fact, in one series of photos of the same eclipse, the curvature varied, and at one stage the curvature indicated the diameter was only about 1.50 times the diameter of the Moon. One photo of an eclipse indicated a diameter much greater than 2.17 times the diameter of the Moon. There are other discrepancies. Some photos of the earlier stages of an eclipse show absolutely no defined outline of a shadow, but only dark smudges on the portion of the Moon being eclipsed. All of this seems to violate all the standard rules of optics. As has already been shown, these rules cannot be successfully applied in astronomy. Variations in the concentration of soft particles throughout space produce refraction effects. In the case of lunar eclipses, this effect becomes abnormal. The portion of space cut off from the radiation of the Sun by the Earth has a much lower soft particle concentration than the surrounding space. This produces a flow of soft particles from all directions to fill the void. As a result, there is a concentration gradient of soft particles surrounding what would be the normal cone of the umbra that becomes progressively less as the cone is approached. A state of equilibrium is never reached because of the Earth's motion through space. This causes the light from the Sun to be refracted away from an imaginary line connecting the Earth and the Moon. Consequently, the umbra of the Earth's shadow will usually be much larger than the Earth at the Moon's distance. Fluctuations in soft particle concentration throughout space and changes in the amount of radiation from the Sun such as during sunspot activity will result in fluctuations in the size of the umbra. This can even occur during the progress of an

eclipse as some of the sequence of photos of an eclipse sometimes indicated. If these changes are great enough, and sufficiently abrupt, there can be no sharp outline of a shadow on the Moon.

It now becomes clear that the size of the umbra is a very unreliable means of determining the size of the Moon. That the dowser's determination of the Moon's diameter is realistic, can be gleaned from other information. Howard Menger, in his book, *From Outer Space*, stated that the mountains on the Moon make those on Earth look like ant hills. This could not be if the Moon were only 2,160 miles in diameter. Astronomical measurements of its mountains by the height of shadows cast, indicate they are scarcely higher than those on Earth. These measurements, of course, are based on the assumed diameter of 2,160 miles for the Moon. Menger is a man of integrity and many of the things stated in his book are in accordance with what has been revealed in this treatise. Shortly after his book came out, he was silenced by the CIA. Despite the relative closeness of the Moon, the methods used to determine its alleged distance required too great a degree of precision for any reliable calculation of its true distance because of the multiple refraction effects already described.

The above-mentioned dowser also determined the thickness of the Moon's shell to be only 115 miles and that the surface gravity is 98% of Earth gravity. This, of course, is in conformity with what has already been revealed. The author was shocked when he asked for the atmospheric pressure at the surface of the Moon. His dowsing indicated between one and two percent that of Earth's atmospheric pressure! He did, however, find the Moon had more atmosphere per unit area than the Earth possessed. The author, after some thought, realized these findings are in harmony with other principles revealed in this book. Much of the soft electrons radiated by the Sun pass right through the relatively thin shell of the Moon without disintegrating and concentrate in the atmosphere on the side opposite the Sun. Such particles are quickly dispersed throughout the Moon's entire atmosphere. As a result, the Moon has an abnormally high negative ion content in its atmosphere. This simulates conditions that exist deep inside the Earth. The high negative charge carried by its atmosphere results in a low pressure at its surface. The Moon maintains its atmosphere because individual molecules are continually losing and regaining negative charges. During the periods the molecules have a high positive charge, they are gravitationally pulled back to the surface of the Moon. This, coupled with the Moon's high gravity and

much greater size than claimed, enhances its ability to retain a dense atmosphere despite a low pressure at the surface. Consequently, breathing would be no problem on the Moon. Also, because of the high negative ion content, one would not have to breathe as much as is required on Earth. Oxygen has a tremendous affinity for soft electrons. This is why oxygen must be in the air we breathe.

An interesting question now arises: Why is the umbra of the shadow the Moon casts on the Earth during solar eclipses so tiny in comparison to the Moon's diameter? The Moon's shell is ultra-thin compared to that of Earth. Also there are no large openings to dissipate excess particles that collect in the interior as is the case with Earth. As a result, large concentrations of soft particles that are not absorbed in its atmosphere, travel in the general direction of the Earth. Also, a large percentage of these particles are comprised of light in the visible range as a result of the redistribution law. Such concentrations of particles refract visible light more readily than other particles. Therefore, light from the Sun is refracted toward the imaginary line connecting the Moon and Earth to an abnormal extent as it grazes the periphery of the Moon.

Since the umbra of the Earth's shadow on the Moon varies considerably in size, it is to be expected that the umbra of the Moon's shadow on the Earth during solar eclipses should also fluctuate to a degree that cannot be explained by variation in the Moon's distance from the Earth. This happens to be the case. Charles Fort cited a memorable instance where the Moon's shadow was much larger than it was supposed to be.

Another indication this 5,200-mile diameter for the Moon is valid came when the astronaut Armstrong was apparently caught off-guard. An associate of the author had an opportunity to ask him how big the Earth looked from the Moon. (There were no others around). His answer was "about the same as the Moon looks from the Earth!" This associate immediately concluded he was lying.

From the above data, the size of Mercury and Venus can be closely approximated. Since the diameter of the Earth's orbit is nearly three times as great as is claimed, the orbital diameter of Mercury and Venus are correspondingly about three times as great as the listed values. From their apparent diameters, it can be concluded that the diameters of Mercury and Venus are approximately three times as great as the astronomers claim. It follows that Venus has a diameter of about 23,000 miles and Mercury over 8,000 miles.

The retrograde motions of Jupiter and Saturn are large enough to allow a reasonable approximation of the ratio between their distances from the Sun and that of Earth. It follows that the discrepancy between the alleged diameters of these planets and their real diameters is about the same as that involving Mars. Therefore, Jupiter has a diameter of about 230,000 miles while Saturn's is approximately 200,000 miles. This conforms with the results obtained by the dowser.

It is ironic that some of the astronomer's own data have been used to confute much of their alleged findings. This is because some of the measurements didn't require a high degree of precision in order to gain a good approximation of their true values, while others that did require great precision such as the determination of the astronomical unit could not even be approximated by standard procedures. The retrograde motions of Uranus and Neptune are too small for a reliable approximation of their sizes. Also, orbital periods are no guide.

Since any values obtained by dowsing cannot be substantiated by other means, the author has declined from giving any estimate of their sizes or distances. It is logical to conclude, however, that planetary orbits will only be far enough removed from each other to prevent excessive perturbations when any planets are in conjunction. This would place Uranus' and Neptune's distance from the Sun as somewhat less than claimed and correspondingly closer to Earth. It follows that their diameters are less than they are supposed to be.

Since astronomers have no reliable means of calculating planetary distances, it is charitable to consider any claims of accurately determining stellar distances as merely gibberish. The distance of the closer stars is allegedly found by measuring their parallax with the diameter of the Earth's orbit as a baseline. Two observations are made with six-month intervals. There is supposed to be a slight apparent displacement of the stars as the Earth moves from one part of the orbit to the opposite side. The nearest star is supposed to be four light years away and the diameter of the orbit is allegedly about 185 million miles. This would produce a displacement of about 1.5 seconds of arc. It is like viewing a nickel from a distance of two miles. The margin of error is compounded because the observations are six months apart. The variation in concentrations of soft particle in outer space is sufficient to render the measurement of any parallax an impossibility, even if the observation could be made from two points simultaneously. This is to say nothing of the fluctuating refraction effects of our atmosphere. The parallax of mountains only a few miles

away are made with a surprising margin of error, as has been shown above.

Even without consideration of the disrupting factors in outer space and the atmosphere, the degree of precision required to determine such minute displacements as claimed by astronomers, is truly astounding. One can only marvel at the type of magic astronomers must employ in their profession. It is the author's opinion that the moral character attributed to them by Charles Fort transcends their intellectual integrity.

It seems that, according to a logical cosmic plan, star systems should not be any further removed from each other than is necessary. That is to say, the radiation effects from each have minimal effects on any of the others. It does not require separations of light years. One need only look at constellations and star clusters objectively and logically to realize that they are relatively close together. For example, two stars about the size of our Sun, one light year apart, would be about 3,500,000 diameters from each other. Consider two fairly close stars in a given cluster or galaxy that are about the same distance from the observer. Could they possibly be much over a few thousand diameters apart, let alone three and a half million?

Early astronauts reported that the stars are not visible above the atmosphere. They are made visible in the atmosphere because their light is diffused, producing greatly enlarged and distorted images of their discs. Diffusion of such magnitude does not occur in outer space, and geometric optics would apply. As a result, the stars are too distant for their outlines to be resolved by the naked eye. This does not mean that they are light years away. They can be seen easily with moderate size telescopes. This has been demonstrated by small observatories placed in orbit above the Earth. If they were as far away as is claimed, none could be seen by even the most powerful telescope in the world.

It is evident there are minimum and maximum sizes a star can be. They cannot be much larger than our Sun. A reasonable estimate of a maximum diameter would be about 3,000,000 miles. At four light years away, such a star would have an apparent diameter of about .022 seconds of arc. About 1.5 minutes of arc is the minimum resolution of the human eye. This means that a telescope would require resolving power 4,000 times that of the eye to make such a star visible at the distance of four light years. This, of course, is not taking into account the massive attenuation effects mentioned above. When this is taken



into consideration, the value 4,000 would likely have to be increased several times for such a distance.

With the principles which have been introduced in this chapter, the maximum distance of many of the stars can now be very roughly estimated. The apparent diameter of a given star as viewed through an orbiting telescope of known power can be determined. With the knowledge that its maximum diameter is about 3,000,000 miles, the distance can then be approximated. This is based, of course, on the assumption that light follows only the inverse square law.

## **THE ROLE OF GIANT UFOS IN COSMOLOGY**

Some of the "stars" astronomers have thought to be solar systems are no doubt giant space ships of planetary sizes relatively close to us. As mentioned in Chapter 1, Fort cited instances of stars suddenly changing positions and even vanishing. A notable case of the present day is a "star" that has been observed for decades by many observers including the author. It is of the first magnitude and continuously fluctuates in color. Its position in relation to other stars has changed considerably on numerous occasions during the past 25 years. As is to be expected, astronomers have conveniently ignored this phenomenon. The most notable case of a giant UFO mentioned by Fort occurred during the last century. A spindle-shaped object, perhaps larger than the planet Venus, passed through the solar system. During its passage it came close to the Sun and seemed to be immune to the gravitational field of the Sun or of any of the planets. After it was reported by some astronomers, the incident was treated in the same manner in which all such anomalies are treated by the scientific community. Large spaceships passing close to the Earth would account for large areas on the Earth which have been blacked out for hours during the day. There have been several such occurrences recorded. Fort even mentioned a few cases.

It is more than likely that giant UFOs have been deeply involved in notable events of the past which have never been explained. For example, the great flood of Noah's day seems to defy all the rules of elementary physics and common sense. It was supposed to have been produced by a rain that pelted the Earth for 40 days and nights. How could such a rain cover entire mountain ranges? The hardest rain on record, going continuously for 40 days and nights, could not

account for more than about 200 feet of water. Yet this flood covered Mt. Ararat, which rises three miles above the surrounding country. In any event, where would all the water come from that could produce a violent rainstorm lasting for 40 days? Interestingly enough, records kept by other peoples on other parts of the globe mention a similar flood, and geological evidence confirms it. Rain could account for only a small percentage of the water involved in the flood. Where did this extra water come from and where did it go after it receded?

The only answer is giant spaceships, with levitation beams that can move planets from one place to another and to different orbits. A levitating beam or beams of sufficient magnitude to move the Earth to a different orbit would displace large portions of the oceans, causing land masses to be inundated. After the moving process was completed, the displaced oceans would return to their former positions.

No doubt prior to the flood the Earth was in a different orbit, in full view of the binary Sun, and perhaps closer to the Sun than it is now. Its surface would be protected by a great mantle of water vapor as is the case with the planet Venus. When the Earth was moved into its present orbit, this mantle of water vapor quickly condensed as rain.

There are other types of catastrophic events that cannot be explained by natural means. These include polar shifts, earth upheavals that produce mountain ranges and earth magnetic polarity shifts due to changes in the direction of the Earth's rotation and changes in the axis of rotation. The evidence is overwhelming that these changes took place in a very short time. All of this has been adequately covered in the books written by the great scholar Emmanuel Velikovsky such as *Worlds in Collision* and *Ages in Chaos* and *Earth in Upheaval*. He researched ancient literature in various parts of the world and found consistent accounts of a global catastrophe, as a result of the Earth tumbling on its axis. This included records of the Sun and Moon rising in the west and setting in the east. The annals of ancient Egyptians state that the course of the stars had changed direction four times since they had kept records. They also mention that the Sun set twice in the sky where it now rises.

There are also accounts of the Sun and Moon standing still for periods of time. There are other records of the remote past that state that the night did not end for four days. In other words, there is cor-

roborating recorded evidence in various parts of the world that there was either a prolonged day or a prolonged night.

From the explanation already given for geomagnetism, such changes would reverse the polarity of the Earth's magnetic field. This has been confirmed by polar magnetic records in rocks which show magnetic reversals. Other evidence of sudden polar changes is that of preserved ancient mammoths unearthed in Siberia in a standing position. They had undigested food between their teeth and in their stomachs which consisted of temperate flora. Also, much tropical coral is found in arctic regions. As would be expected, evidence of glacial deposits are also found in tropical areas near the equator. There is also a great deal of geological evidence that some of the higher mountain ranges such as the Himalayas were formed very quickly. Mayan literature tells about the face of the Earth changing, mountains collapsing, and other mountains growing. Velikovsky also found evidence that the Himalayas did much of their growing in historical times.

The logic employed to explain polar flips and changes in the direction of the Earth's rotation is not only tenuous but infantile. The standard explanations involve meteor impacts, great earthquakes and the thickening of the ice caps in the polar regions. The analogy of the spinning top with melted wax dropped on it to produce a wobble has been given. The gravitational pull on the Earth by the Sun is much too feeble to cause even a relatively slight unbalanced condition brought about by increases in ice caps to cause polar flips within billions of years. If it did occur in this manner, then a rotation on a new axis would be mandatory. Otherwise, one part of the Earth would always face the Sun while the rest of it would experience permanent darkness. A change in rotation on a new axis would require a great coupling force. It is indeed incredible that none of the distinguished writers and authorities who recognize the reality of such Earth changes in the past have not seen the gross inadequacies in these explanations.

Once again, the only manner in which the Earth could have been manipulated to produce these recorded Earth changes is by giant gravity-inducing beams emanating from spaceships. Great precision is required in such an endeavor. Due to the limited penetration of such gravity beams, the forces needed to move the Earth in the above manner would be concentrated only in the outer layers of the Earth's crust, and only on a small percentage of the surface area.

The stresses produced in such areas of the crust would be colossal. It is analogous to throwing a bull around by only grabbing its tail. The tail and areas around the base would take up all the stress. The source of the tremendous earthquakes and great movements of land masses to form mountains now becomes apparent.

The question remaining is why there are periodic manipulations of the Earth with accompanying cataclysmic events. According to geologists, magnetic polarity has changed at least 171 times in the past 76 million years. When farm land is overworked, it must lie fallow for awhile, in order to recuperate. Was this same pattern applied to the Earth in general? The inhabited portion of the Earth and the temperate zones that support vegetation become depleted after thousands of years, much in the manner of overworked farm land. The desert areas, land covered by ice and portions of ocean bottom were once inhabited and supported a great deal of vegetation. They are now like a field lying fallow, slowly being rejuvenated and cleansed by radiations from the Sun and outer space. Not only is the land depleted in inhabited areas, but pollution in various forms including inimical energies and thought forms accumulates in intolerable amounts.

There are other reasons for manipulating planets and even changing their orbits on occasion. Ancient records, including testimony from outer space aliens, tell of a planet in the solar system that was destroyed in interplanetary war. It was in the orbit occupied by the Asteroid Belt. Debris from this blown-up planet has imperiled the entire solar system. Since a planet would scatter debris in all directions after it blew up, the Asteroid Belt would represent only a fraction of the material that comprised the original planet. The rest of the fragments would be orbiting the Sun in a myriad of orbits and orbital planes. If a planet happened to be on a collision course with some of the more dangerous concentrations, it would have to be moved out of the way and its orbit changed; very likely such an incident with Mars and Venus, as described by Velikovsky in his book *Worlds in Collision* occurred. This book gives an account of these planets coming dangerously close to the Earth and both of them almost colliding with each other before they assumed their present orbits. Prior to this, Venus was not seen as a morning and evening star. It was described as a comet that came from outer space. If the gravitational field of Venus had captured some of the debris from the destroyed planet as it was towed out of its previous orbit, it

would have given the illusion of being a comet. Overwhelming evidence that something akin to this has happened to Venus again is an obvious recent change in Venus' orbit.

## RECENT AND OBVIOUS CHANGES IN VENUS' ORBIT

The maximum angle of separation between Venus and the Sun when viewed from Earth is the ratio of the arc sine of radius of Venus' orbit and the distance of the Earth from the Sun. According to the text books this angle is  $47^\circ$ . Until recently this has been the case since the ratio between the size of Venus' orbit and that of Earth can be determined with a reasonable degree of accuracy although, as has already been shown, there is a great disparity between astronomical determinations and the real value. During the late '70s the author noted that Venus at times was much higher in the sky after the Sun set than it should have been. On March 31, 1988 Venus set 4 hours 15 minutes after the Sun! This is a whopping 64 degrees. Interestingly enough after Venus' return as an evening star in 1990 this maximum angle was less than 45 degrees.

Observations made in June 1993 again show these obvious abnormalities. On rarely occurring clear evenings in the Portland, Ore. area where these observations were made Venus was seen setting over four hours after sunset. Evidently this angle had not yet reached a maximum. During the last check-up Venus again set 4 hrs. 15 minutes after the Sun. It may or may not have reached a maximum. Even more amazing, Venus was much higher above the horizon than the Sun reached during the day and set much further along the horizon than did the Sun. This means the plane of Venus' orbit is now considerably different from that of the Earth. All the orbits of the planets are supposed to be in nearly the same plane.

As to be expected astronomers including the scientific community have seen fit to ignore one of the most amazing astronomical events in history. In fact a recent edition of *Astronomy*, stated (in the face of all this) that Venus' separation from the Sun never exceeds  $47^\circ$ ! Once again this demonstrates the total lack of integrity in the scientific community and its refusal to face facts that are damaging to its accepted dogmas.



Perhaps the most convincing fact that confutes the astronomers claim that Venus has a consistent orbit is the alleged 588 day cycle. It is supposed to take Venus 588 days to gain one revolution around the Sun on the Earth. In other words, from the time Venus reaches a maximum distance above the horizon after sunset, it requires another 588 Earth days for this to occur again. On March 31, 1988 Venus reached its maximum distance above the horizon. The next or last time it reached this maximum was about March 1994. (The author has not made any subsequent observations of Venus). According to the 588-day cycle this should not have occurred until Sept. 1994. It is also interesting to note Venus never got more than  $30^\circ$  above the horizon during the last maximum. What more evidence does the reader need to realize this writer's contempt for the scientific community is more than justified.

According to old records dug up by Velikovsky and others, it is indicated that we didn't always have our present Moon. It is a comparatively late arrival and was likely a Moon of the planet that was disintegrated. This planet, incidentally, was known as "Maldek".

## **RESOLVING OLBER'S PARADOX, THE RED SHIFT AND RELATED PHENOMENA**

There is a paradox associated with cosmology which has never been resolved by conventional scientists, despite their claims to the contrary. It is known as Olber's paradox and is based on a principle of elementary mathematics. It assumes that the average distribution of stars remains about the same throughout the universe. Although the distribution is not uniform, the average number of stars in space within a certain distance of us varies directly as the cube of the distance, since the volume of the space involved varies in this manner. From a conventional standpoint, the light intensity from any star varies inversely as the square of its distance from us. This means that the amount of light received from the stars within a given distance varies directly with that distance. For example, the total amount of light received from all of the stars within 100 light years will only be one-half as great as the amount received from all the stars within 200 light years. If the universe extended beyond the four

billion light years in which astronomers claim to have recorded stars, the sky should actually be blinding in all areas, instead of being black. Scientists have been consistent and provided a solution to this dilemma, which shows the same bad logic as many of their other theories.

Their explanation is that the more distant stars are receding from us at higher velocities, as indicated by the red shift. Even if this were true, the implications of Olber's paradox still hold. The most distant stars photographed still project as much light to us as before. While the visible frequencies are shifted toward the red, the ultra-violet must be shifted toward the visible and, therefore, the red shift does not resolve the paradox.

Some of the principles already discussed resolve Olber's paradox and explain the red shift at the same time. Space is permeated with soft and hard particles of all kinds, which stars have been continually radiating for millions and even billions of years. Light continually interacts with these particles when passing through space and the law of redistribution of energy takes over. In this manner, light from any star is steadily brought down to ever lower frequencies. It follows that the more distant the star the greater the average frequency decreases. The astronomers guessed right in this instance. The more distant the stars, the greater the red shift. Their conclusion was correct, but their explanation was wrong. The red shift is merely due to the law of redistribution of energy. At the same time the light is dispersed and attenuated to a degree far more than can be attributed to the inverse square law.

Therefore, light from the more distant stars is either dispersed or transformed into frequencies below the visible range. The starlight, which barely shows up on photographic plates, has been so thoroughly dimmed, which is in accord with the redistribution law and normal dispersion, that an illusion is created that the stars are far more distant than they appear to be. It now becomes apparent that Olber's paradox is no longer a paradox.

As stated earlier, stars are made visible in our atmosphere by the diffusion of light, which forms greatly enlarged but distorted images of these disks. Light from distant objects, which subtend very small angles, is diffused outward from the original light rays after they enter the atmosphere by an amount which deviates very little from a certain constant. For a closer body such as a planet, whose disk subtends an angle much greater than that of a distant star, this con-

stant does not magnify or distort the diameter by nearly as great a factor as that same constant added to a very minute apparent diameter.

The fallacies of the "Big Bang Theory" and the conventional interpretation of the red shift have come into evidence by an enigma known as the quasar. Quasars are celestial objects with abnormal red shifts. If they were as far away as the red shift indicates, then in order for them to be visible to the extent they are, some of them would have to be 1000 times as bright as the entire Milky Way galaxy! An astronomer by the name of Halton C. Arp, with obviously better mental acumen than his illustrious colleagues, has shown by a brand of logic and intelligence uncommon for a man in his profession that quasars must only be a minute fraction of the claimed distance from us. He has found a surprising number nestled in the spiral arms of some spiral galaxies which are relatively close. Statistical analysis shows an overwhelming probability they are a part of such galaxies. To assume otherwise would be stretching coincidence much too far. As is to be expected, this has not endeared Arp to most of his fellow astronomers. It is indeed refreshing for a professional astronomer to finally appear in modern times with at least a modicum of intelligence coupled with integrity. Charles Fort would have been rendered speechless. The exact antithesis of Arp is an astronomer who has received a lot of publicity in recent years. He is a "famous" popularizer of the fallacies and dogmas of academic astronomy and cosmology. He is to these subjects what Asimov is to the other realms of orthodox science. The reader already knows his identity. He is, of course, none other than Carl Sagan.

A quasar is undoubtedly a moderate sized radiating body of a size approximating that of our own Sun. The abnormal red shift can be attributed to an inordinate concentration of soft electrons or rarefied gases of great thickness surrounding that body. The light from such a body would consequently experience a considerable red shift as a result of the redistribution law.

Spectral lines by which the red shift is determined do not experience as great a change in frequency as does the rest of the light radiated by such a star. This is because the light comprising a spectral line is more concentrated than the other frequencies. The rays of light of which a given spectral line is composed are far more numerous. Consequently, the light from a star will travel a greater distance

before all of the rays of that line experience a drop in frequency. The laws of probability play an important role in this process.

## FLUCTUATIONS IN THE VELOCITY OF LIGHT

It was shown earlier that light passing through concentrations of soft particles will tend to lose velocity, as it does when going from one medium into a denser one. The concentration of soft particles throughout space, and especially around planetary bodies such as the Earth, is not uniform. Therefore, measurements of the velocity of light will fluctuate. This fact was unwittingly demonstrated by physicists with the Mossbauer effect, which they thought was a confirmation of General Relativity. Accurate determinations of this velocity will find not only 24 hour fluctuations, but also seasonal ones and significant changes during sunspot activity. The velocity will be found to be less during the day than at night and also during the summer and, especially, during sunspot activity. This, of course, is because the concentration of soft particles is greater during these periods.

Countless determinations made during the 1930s with a mile long evacuated tube indicated that there were fluctuations much greater than could be attributed to experimental error. Reports were not explicit in stating whether the velocity fluctuated according to the rule mentioned above, but they did state that there were daily and seasonal variations. This fact was too damaging for the world of official science to tolerate, since the velocity of light heretofore was supposed to be the universal constant. What have the physicists done about it? Perhaps the reader has guessed it.

Present day encyclopedias do not mention these embarrassing deviations. The list of measurements and their dates in chronological order suggests ever more precise determinations over the years, which have been progressing toward the final exact measurement of this "universal constant". They conveniently left out all the data which occurred between these dates, which don't fit this pattern. One might wonder how soundly physicists sleep at night. Perhaps not as well as the astronomer Charles Fort wrote about. An older physics textbook on optics which was used about thirty years ago, entitled *Physical Optics*, by Robertson, mentioned these various discrepancies. Robertson disposed of the anomaly by suggesting that

the fluctuations were probably "more instrumental rather than real". What the author meant by this nebulous and contradictory statement was not made clear. He had already stated that these fluctuations were greater than those which could be attributed to experimental errors, which naturally includes instrumental errors. Evidently, Robertson was one of the great masters of the art of doublethink.

It would seem that if the Michelson-Moreley Experiments were to be performed on the outside of a small spaceship traveling in free space at a very high velocity that positive results could be obtained. It would not show ether drift, but it would show soft particle drift. A large body like the Earth with a dense atmosphere and a far greater concentration of soft particles at its surface than exists in outer space would prevent such a result. The Earth tends to carry all of the soft particles in the vicinity along with it. Therefore, no soft particle drift would be detected. As mentioned in the chapters on Relativity, no ether drift would be detected because the ethers offer no resistance to the passage of light.

As indicated earlier, faster moving light produces effects similar to that of higher frequencies moving at a lower velocity. Conversely, light traveling at lower velocities behaves in a manner similar to that of lower frequencies moving at higher speeds. This is what creates the Doppler effect of light. For example, the rotation of the Sun produces the red shift on the side of the Sun moving away from us, and the blue shift on the opposite side which is moving toward us. In the latter case, the light is moving faster, because it has the rotational velocity added to its velocity relative to the source. In the former case, the rotational velocity is subtracted from the velocity relative to its source and therefore it is moving at lower velocity, since the light source is moving away from us.

The reasons on the basis of concepts introduced earlier is not difficult to understand. The higher frequency light is comprised of photons and soft electrons associated with the higher ethers than that of lower frequency light. For a given velocity the photons and electrons of the higher frequency light will interact with matter more readily than those of the lower frequencies. So, within certain limits, the lower frequency photons and soft electrons will interact in a manner similar to that of the higher frequencies, when they travel at a higher velocity.



## THE ORIGIN OF MOON CRATERS

The consensus seems to be that Moon craters are caused by the impact of meteors. This is consistent with the quality of logic displayed in other areas of orthodox cosmology. The diameter of most of these craters is disproportionally great compared to their depth. A true impact crater has a depth commensurate with its diameter. An impact great enough to produce a crater with a diameter of some size on the Moon would shatter the entire Moon, since it is hollow with a relatively thin shell. To wit: some craters have a mountain in the center. It is significant that, in all cases in which the crater has a mountain, the mountain is always in the center. How did it ever escape destruction?

The only logical answer is that the craters were produced by particle beam weapons during the great interplanetary war. This, no doubt, was the one mentioned earlier, when the planet Maldek was destroyed. Other planetary bodies show similar craters, for instance, Mercury, Mars and the moons of Jupiter.

A concentrated beam of high speed positive charges, preferably protons, can have devastating effects, if directed against a specific target. The beam by itself does relatively little damage. It is the after effects that are destructive. While in motion, the positive charge effects of the particles comprising the beam are minimal. After they strike the target, they lose their velocity and a tremendous positive charge is concentrated at the point of impact. This charge is maintained by incoming particles. A high concentration of soft and hard electrons converges on the area from all directions, creating a void in the regions originally occupied by these particles. Others rush in to fill the void and a chain reaction, or domino effect, is produced which affects the regions of space at ever increasing distances around the target area. The number of electrons that converge on the area is far out of proportion to the number of protons concentrated in the area.

The ramifications are not difficult to imagine. The soft electrons congregating there disintegrate and release the hard electrons they contain. An inordinate concentration of hard electrons is the result, and is far more than can be absorbed by the protons. First, an implosion and then an explosion of electrons of colossal proportions are created. Most of the energy of the explosion is directed outward,

since it follows the lines of least resistance. The number of particles involved and the amount of energy released can far exceed that of any nuclear device. Since the energy is directed outward, extremely wide but relatively shallow craters in a planet's surface result. The principles involved in such destructive forces are similar to those employed by Wilhelm Reich's cloud-buster, which will be discussed later. The center of the craters produced would experience a relatively small disturbance and, consequently, any mountain in the path of the proton beam would be left standing.

The fallacies in universally accepted cosmological dogmas have now been made apparent. One fallacy which has been gaining some popularity and acquiring a wider acceptance among astronomers and astrophysicists in recent years is the Big Bang Theory. According to this misconception, the universe began with a giant explosion billions of years ago and the universe which resulted has been flying apart and expanding ever since. Of course, all life came about by the chance combinations of various atoms and molecules. The outermost portions are receding from the center of this explosion at a higher velocity than those which are closer to the center. The famous red shift is the main basis for this concept, which is a very worthy concept, and as such capable of taking its place among the other celebrated theories of academic science such as Relativity, tidal theory, concepts in particle physics and other products of the "fertile" minds of modern physicists. The Big Bang theory at least demonstrates consistency in the quality of thinking among orthodox scientists.

## **ADDENDUM TO CHAPTER 15**

As mentioned in this chapter, the evidence that Mars has an extremely dense atmosphere (in fact much denser than that of Earth), is overwhelming. This would account for its red color. Much of the visible light reflected from its surface that reaches us, is brought down to the lower frequencies by the redistribution law since it must pass through a dense and extensive atmosphere. Its color will resemble that of its sky. It is interesting to note that astral travelers who have visited Mars (and the author knows one personally) claim that its sky is red. This principle would also account for the Moon's yellow appearance.

There is sound evidence, as will be shown further in Chapter 18, that the Moon has much more atmosphere than the Earth. Howard Menger claimed that the Moon has a yellow sky. Interestingly enough, the Earth has a blue tinge when viewed from outer space. Its sky, of course, is blue.

The fact that the color of the sky and the color of the planet as seen from outer space, and even through the atmosphere of another planet, is the same, seems to present a paradox. Since the light must travel through the atmosphere twice and again through the atmosphere of another planet, as is the case of Mars and the Moon as seen from the Earth, it follows those bodies should have a color representing light brought down to the lower frequency ranges according to the law of redistribution.

The paradox is resolved when the following is considered. When the photons and soft electrons of which light is comprised, interact with matter the more unstable particles including photons, disintegrate. During the process, ethers are disturbed with the creation of new photons with a lower average frequency than the original photons. (It should be mentioned at this point that the more unstable photons consist of ether particles with a wider range of frequencies or sizes than the more stable ones). As the light from the Sun reaches the lower levels of the atmosphere, the average frequency of the incoming light becomes progressively lower. When this light collides with the surface of the planet, the more unstable particles disintegrate and are not reflected. The light that is reflected consists of the more stable particles which are little affected in passing back through the atmosphere and through that of another planet.

A recent and very excellent book by Daniel Ross titled, *UFOs and The Complete Evidence From Space* confirms what has been shown in this treatise concerning conditions on Venus, our Moon and Mars. It seems Ross had access to close-up pictures of these bodies taken by NASA, which were never made available to the American public. He obtained them outside the United States. Some are clearly duplicated in his book. One of them shows vegetation extending nearly to the top of Olympus Mons, thereby indicating a tremendously dense and extensive atmosphere on Mars. The same picture showed a cloud high above the summit. A close-up photo taken on the other side of the Moon displays large bodies of water and even forests in the higher latitudes. This book also gives unmistakable evidence of earth-like conditions on Venus. Ross has stated that Adamski was informed by

space visitors the Moon had an atmospheric pressure of 6 p.s.i. This differs slightly from the findings of the dowser mentioned earlier. However, dowsing is not always 100 percent accurate, and even the best dowsers sometimes stumble a bit. The 6 p.s.i. seems more realistic and still indicates a very high negative ion content in the Moon's atmosphere. This means more healthful conditions exist on the Moon than on the Earth. The author has heard Ross lecture and despite the fact he is very knowledgeable and an intelligent and dedicated researcher, it is evident he is still too young for the full magnitude of "Sciencegate" to have dawned on him. His book is gaining great favor and it is hoped it becomes an international bestseller, as it deserves to be.

Evidence shows that information damaging to establishment science and old dogmas is withheld from the American public far more than from people in other countries, as is proven from Ross' experience. This is only part of the evidence. As mentioned in Chapter 1, Canadian newspapers published accounts of Astronaut's conversations with their superiors on the Earth that were suppressed in the United States. Also back in the 50s, the author saw a photo of the Moon taken by our 200-inch telescope, showing a large man-made structure. It had been sent to an associate of the author by a friend in Germany! Such a picture has never been released in this country.

Evidence shows that the Moon does not experience the extremes of temperature one would expect from the long days and nights. This can be readily accounted for because of two factors, the extremely high concentration of soft electrons in the atmosphere and their degree of stability. The particles that accumulate in the atmosphere are the more stable ones. This means fewer disintegrations which release hard electrons and also a tendency to absorb excess hard electrons that are released. This blanket along with the dense atmosphere, tends to minimize the escape of heat from the surface during the long nights. A similar process prevents temperature extremes on Mars. Mars undoubtedly has a relatively thin shell like the Moon since it does not seem to have large openings into the hollow interior. The resulting high negative ion content would prevent gravity from compressing the atmosphere to the extent the Earth does its atmosphere. Consequently, the air density would not drop off with increase in elevation as rapidly as it does on the Earth. As a result, ideal temperatures and atmospheric densities would exist at extreme elevations, as is shown on Olympus

Mons at about 75,000 feet. Similar conditions would exist on the Moon.

Despite the fatuous conclusions of astronomers and cosmologists, it is logical to assume all planets in our system support intelligent life. In fact, far more intelligent as a whole, than life on this planet. According to their specious arguments, conditions on all of the planets except Earth are too severe to support life as we know it. Planetary systems are created according to intelligent design. This rules out the possibility of dead planets orbiting the Sun. The late Ufologist and contactee, George Adamski, wrote several books describing his experiences with aliens and outer-space trips he took in their spaceships. Since this occurred long before outer-space exploration by the present so-called civilization of this planet, it is remarkable that the things he saw and described were later confirmed in every detail by NASA as related in Daniel Ross' book. This included, of course, earth-like conditions on the Moon. This adds credence to other claims by Adamski that he was informed all of the planets in this system except Earth, have advanced civilizations. The reasons given to him for the inner and outer planets being habitable unfortunately ranged from the very tenuous to complete nonsense. For example, it was said that if planets did not have sufficient atmosphere to offset internal pressures they would all have disintegrated and returned to the elements of space long ago. Let's consider the Earth, for example. Our atmosphere exerts an average pressure over the Earth's surface of about 14 p.s.i. This is supposed to offset internal pressures tending to expand the Earth outward and causing it to explode. Assuming such an inner and outward pressure exists (and the author has already shown that the hollow planets do have a tendency to expand), the pressure of the atmosphere would contribute only an infinitesimal portion of the force tending to offset this compared to many miles of Earth crust pushing in the same direction. This also includes the average two-mile depth of the oceans, tending to do the same thing.

As for the outer planets having earth-like conditions at the surface as claimed by Adamski, the fact that their surfaces reflect a lot of sunlight adds support to this claim. This is a fact astronomers tend to ignore. Through powerful telescopes Uranus, Neptune and Pluto appear as bright spots or discs. According to the inverse square law, Pluto should only receive about 1/1000 as much light per unit area as Mars, which would indicate its surface would be only 1/1000 as bright. This means it would be too dull to have ever been discovered



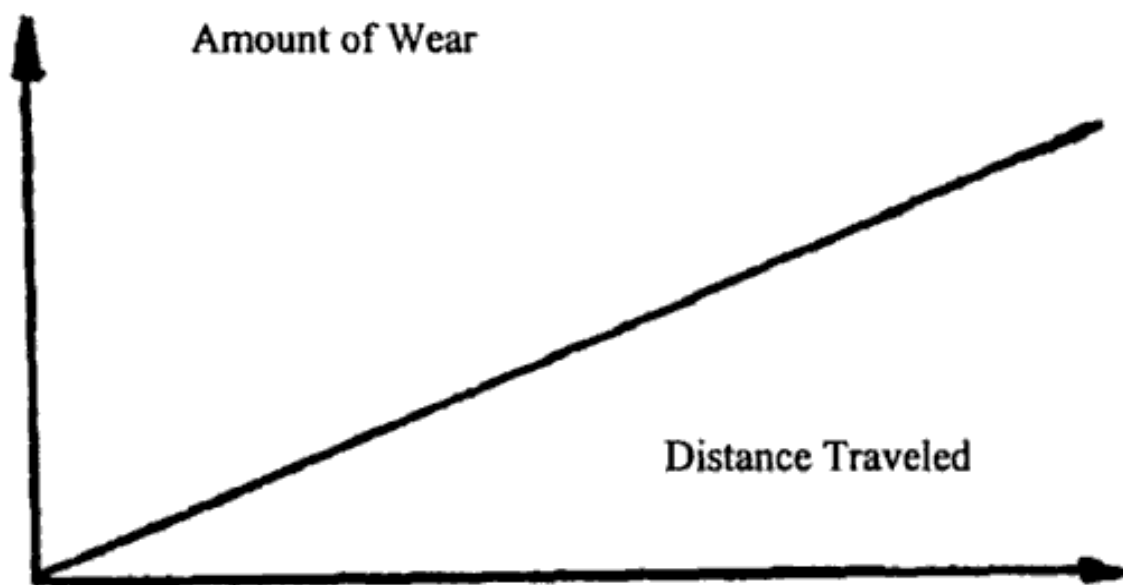

**FIG. 22: GRAPH SHOWING AMOUNT OF WEAR VERSUS DISTANCE TRAVELED**

*A relationship can be derived between the distance the light travels and the percentage of the light particles that become worn enough to disintegrate while passing through an atmosphere.*

in the first place. When the discs of the outer planets are resolved by telescopes to the same number of degrees of arc they are all of about the same degree of brightness.

Adamski's explanation for this dilemma as given to him, leaves a lot to be desired. According to this explanation, the Asteroid Belt acts as a dielectric, which stores electrical energy by trapping a portion of the Sun's energy and at the same time giving energy to particles passing through. The alternating current action is supposed to make the Asteroid Belt a transmitter of electromagnetic energy. This effect is supposed to supply the outer planets with the additional light and heat. The additional energy imparted to the "positively charged particles" from the Sun would register as higher kinetic energy (temperature) by

a space probe passing through the zone. This effect was confirmed in 1978 by a space probe. The space people knew of this effect and explained it by increased kinetic energy of solar particles. This explanation is false since the space people evidently had no comprehension of soft particle physics or the true nature of the light radiated by the Sun. These particles are a combination of negatively charged soft electrons and photons, as described earlier. When they collide with the fragments of the Asteroid Belt many of them disintegrate releasing high concentrations of hard electrons which produce the heat effects measured by the space probe. The particles and fragments comprising the Asteroid Belt are so sparsely distributed, only a very minute portion of the radiation from the Sun is trapped. Therefore, even if the effects claimed by Adamski's space contacts were valid, additional radiation transmitted to the outer planets would be too minute to make any significant difference. The theory collapses completely when it is considered that the Asteroid Belt is the remnant of a planet called Maldek that was destroyed.

That all the planets in our system have Earth-like conditions on their surfaces seems to present an insurmountable paradox. The inner planets should be too hot to support life as we know it, while the outer ones would be too cold. The paradox is readily taken in stride by the concepts elaborated upon in this treatise. As stated earlier, outer space is permeated with soft electrons of all kinds. Particles radiated by the Sun steadily experience attrition or wear as they encounter these soft particles during their passage through space. This attrition renders them less stable and more likely to disintegrate when they enter an atmosphere. The radiation from the Sun received by Mercury is largely of the more stable variety than that which reaches the outer planets. Consequently, a far lower percentage of the soft particles radiated from the Sun disintegrate as they pass through Mercury's atmosphere than the radiation that reaches the other planets. It should be remembered that it is the particles that disintegrate which produce light and heat.

It can be assumed that the degree of wear is directly proportional to the distance traveled. Therefore, the degree of attrition is a linear function, as shown by the graph in Fig 22. At the present time, there are too many factors to determine the rate of attrition or the slope of the line. It is not necessary anyway. The area under the line or curve represents the amount of soft particles that will disintegrate while passing through an atmosphere. It can be seen that this will vary as the

square of the distance traveled. This means that although the intensity of the radiation from the Sun drops off inversely as the square of the distance the percentage of the radiation remaining capable of producing light and heat increases as the square of the distance. It follows that the amount of heat and light per unit area received by any of the planets is nearly a constant. Of course, beyond a certain distance this won't hold because the intensity becomes too small to produce sufficient light and heat even if 100% of it is converted.

There is one enigma that remains. If our Sun is a binary, then it appears our planet receives only about  $\frac{1}{2}$  as much light and heat per unit area as the other planets, which would be in full view of the binary. A belt consisting of an abnormal concentration of soft electrons surrounding the Earth would accomplish this. This belt would render the soft electrons radiated from the Sun to a more unstable condition by the time they reach the Earth. Perhaps this is the purpose of the Van Allen Belt. Consequently, if the Earth were in full view of the binary Sun, it would receive more heat than the outer planets. This in turn would be compensated for by the rapid formation of a dense mantle of water vapor produced by the boiling of the oceans. It follows that the Earth would be the only planet in the system with such a belt unless some of the outer planets have large bodies of water like the Earth. For the same reasons the Moon should also have a similar belt. This has been confirmed.

The above analysis demonstrates the power of the new science revealed in this book which easily resolved a paradox beyond the capability of even the space visitors. It is also another demonstration of the fact no adequate understanding of any phenomenon is possible without the concepts of soft particle physics. The author also has other excellent reasons to conclude the teachings expounded upon in this book are well beyond those available on even the most advanced planets. This presents another enigma since this new science had its origin on one of the most backward of planets!

## **JULY '98 ISSUE OF SCIENTIFIC AMERICA "MAN'S PATHFINDER MISSION"**

A recent great confirmation to what has been revealed concerning Mars' atmosphere and its size was unwittingly presented by an article that appeared in the July 1998 issue of Scientific America. The title is "Man's Pathfinder Mission." A computer enhanced photo showed a sunset on the terrain. The sky was red and the light from the sun was far more diffused that it would be on Earth. Since Mars is much larger than Earth, the horizon is much further away. This means the light must pass through a lot more atmosphere. This coupled with the fact Mars has more than three times as much atmosphere per unit area than Earth compounds the situation. It looked as if the sun were peeking through a cloud formation. Sunset was the "ideal" time to take the photo since the other part of the binary had already dipped below the horizon.

Another computer enhanced photo showed blue clouds in the sky. It was stated that of all the water in the clouds condensed as rain it would produce a layer of water less than 1/100 of a millimeter thick. This demonstrates the kind of intelligence prevalent among our venerated scientists. How could such an infinitesimal amount of water produce a cloud, let alone ones as prominent as those shown in the photo.

## CHAPTER 16

# AN EXPLANATION FOR CONDUCTIVITY OR THE RULES GOVERNING THE TRANSMISSION OF HARD AND SOFT ELECTRONS THROUGH VARIOUS MATERIALS

### CONDUCTIVITY AT NORMAL TEMPERATURES AND ATOMIC FIELD ZONES

Hard electrons travel through metals more readily than through nonmetals. This indicates that they encounter more extensive positive electrostatic fields between atoms and molecules than in nonmetals. At the same time, the atoms in metals are usually more mobile or free to move around than is the case with solid nonmetals. This is why the best conductors of electricity are also the best conductors of heat. It is significant that all of the heavier atoms are metals with the exception of radon, which is a gas. This means that such atoms have a higher net positive charge, which causes a stronger mutual repulsion for greater distances on atoms which are not directly attached to each other. This greater extension of the positive zone around such atoms gives them more freedom without breaking the bond which holds them together. The repulsive forces of nearby atoms increase the mobility of any given atom.

The heavier atoms contain more protons and neutrons bunched together. The outside pressure necessary to hold a group of mutually repulsive particles together is independent of the number of particles present. This principle can readily be demonstrated from a one dimensional standpoint. Consider a group of identical springs of a given length. Let  $F$  represent the average force applied over the distance  $L$  in order to compress the spring completely. Assume that there are  $N$  springs independently distributed over a surface. The amount of work required to completely compress all of the springs is



NFL. All of these springs are now arranged in tandem or along a line in order to represent  $N$  mutually repulsive particles. The average force required to compress all of the springs is the same as that required to compress only one spring since this force is transmitted equally to all of the springs. This time the force will act over a distance of  $NL$ . In accordance with the law of conservation of energy, the work required to compress the springs in this case is still  $FNL$ . This means that the pressure required is independent of the number of springs. The same analogy can be extended to three dimensions.

From the above argument, it is apparent that large numbers of protons are as easily contained in a group, as are smaller numbers. This becomes even more evident with the consideration that the larger groups generally contain a higher percentage of neutrons. This means that the activities of most of the protons in the heavier atoms are restricted. This in turn indicates that a lower percentage of their electrostatic potential is transformed into magnetic energy, resulting in a higher net positive charge of the atom. Generally, the elements with the higher atomic weights have a higher specific gravity. There are slight deviations from this rule, however. In some cases the zones of repulsion around atoms can be more extensive and at the same time the zone of attraction less than normal, which results in fewer atoms per unit volume. This accounts for lead having a much lower specific gravity than gold despite the lead atom being heavier than the gold atom.

One might conclude that the heaviest atoms make the best conductors, but this is not the case. Silver, copper, and aluminum are the best conductors. Although their positive field zones are not as extensive, they have less inertia and thus are more easily pushed out of the path of a flow of hard electrons. The arguments presented thus far are not the only factors involved in accounting for small variations in the general rules outlined. The overall atomic pattern is too complex to be covered by this treatise.

Electrons which flow along conductors are continually colliding with atoms in motion. Therefore, it requires a steady application of force or EMF at the ends of the conductor to keep them flowing. The atoms of nonmetals are more firmly locked into position and therefore do not have that much of a tendency to move out of the way. This is why they make good insulators. Electrons, which follow the lines of least resistance, tend to move on the surface of the conductor where there is less a tendency to collide with atoms.

The rules concerning the conductivity of soft electrons are somewhat different from those of hard electrons. Soft electrons are enormous when compared to hard electrons. This is apparent when considering that the average diameter of a particle is directly proportional to the so-called wavelength of the light comprising it, or inversely proportional to the frequency. The ethers associated with atoms and their fundamental particles are much higher than those associated with soft particles. This means that atoms will offer little resistance to the passage of soft electrons. However, the magnetic fields resulting from thermal agitation of certain atoms and molecules are involved with ethers which are closer in frequency to the ethers directly associated with soft electrons. Therefore, soft electrons will interact with these fields. This explains why metals in general offer a greater resistance to the passage of soft electrons than do nonmetals. The atoms or molecules of metals have a greater range of motion.

## **THE PARADOX OF THE TRANSFORMER AND THE SOURCE OF ELECTRICITY IN ANY CONDUCTOR**

The ordinary electrical transformer presents an enigma. The secondary of the transformer continues to pour out or eject electrons indefinitely from a seemingly unlimited source. There is a limited quantity of free electrons in conductors which should be quickly exhausted. The standard argument used to account for the source of current is that free electrons in the circuit supply the electrons and are used over and over again. A simple calculation demonstrates that free electrons in conductors are not the source of electricity.

Consider a wire two millimeters in diameter which carries about 10 amperes of current. The electron flow is concentrated near the surface of the wire. Since the electricity in a conductor travels at about the speed of light, such a wire 186,000 miles long would have 10 coulombs of electricity distributed over its surface at any instant. The surface area of this wire is  $1.84 \times 10^6$  square meters. A parallel plate condenser having a plate of this area with a separation of one millimeter would have a capacity of .016 farads. Even with a potential across its plates of 100 volts, it would still only be able to concentrate an equivalent of 1.6 coulombs, and a good part of this elec-

trostatic charge would be due to the displacement of the electrons and protons of the atoms. This voltage is far more than enough to concentrate all of the free electrons in the plates on the surface. Similarly, all of the free electrons in the wire example would be involved if the current were maintained with 100 volts. Of course, a wire this long would have too much resistance to carry any appreciable current with 100 volts, but this has nothing to do with the argument just given. As a matter of fact, even 6 volts is much more than enough to produce a current of 10 amps in a wire 2 mm in diameter. This can be demonstrated by connecting the poles of a large capacity 6 volt battery with such a wire. Therefore, there aren't enough free electrons in any conductor to supply an appreciable current. This means that the source is from other than free electrons. Since the secondary of a transformer or any insulated wire continues to furnish electrons, the conclusion is that the hard electrons somehow manage to get through the insulation from the outside.

Since a current has inertia, any change in the primary current of a transformer produces a force in the opposite direction in the secondary by the law of action and reaction. This reactive force is manifested by a disturbance of the ethers which produce the EMF. The voltage or EMF is the result of an increase of ether bombardment which has been shown to be the source of electrostatic forces. The EMF induced in the secondary creates a temporary electric void in the wire. This draws negative charges of all kinds to the wire. The softer electrons quickly penetrate the insulation and stop at the surface of the wire since they do not travel as readily through a hard electron conductor. These softer electrons absorb most of the electrostatic forces in the insulation which impede the flow of hard electrons. This opens the door for the hard electrons to pass through the insulation and enter the wire.

Electrical charges, comprised of photons in nearly all the frequency ranges, permeate all space, since they are continually being radiated by stars throughout the universe. They are not so easily detected since they are in the form of conglomerates in which the harder particles reside inside the softer ones. The resulting combinations are highly penetrating and it takes something like an EMF induced in a conductor to separate the harder particles from the softer ones. The performance of a transformer can be greatly impaired by completely shielding the secondary with a good conductor of electricity such as copper or pure aluminum. An associate of the

author has performed this experiment, which verifies the principles just outlined. The shield tends to impede the flow of soft particles to the secondary.

The terms EMF (electromagnetic force) and voltage need further clarification. The true nature of the phenomena associated with these terms has never been fully understood. All that has been known is that if a conductor is exposed to an EMF a flow of electricity is produced. Also voltage is associated with the amount of energy or work a current is capable of producing. An EMF of a given value can induce a current with a definite voltage. The voltage produced is directly proportional to the EMF impressed on the conductor. Also the energy of the current is directly proportional to its voltage. The amperage of a current is a measure of the number of electrons passing through each segment of a conductor per unit time. Since wattage, or the total kinetic energy of this current flow, is equal to the amperage multiplied by the voltage, it follows that the amperage is also directly proportional to the energy of the current flow. Therefore, voltage is a measure of the average kinetic energy of the electrons flowing along the wire. This in turn is directly proportional to the square of the average velocity of the electrons. This simple definition of voltage is sadly lacking in all standard textbooks.

An EMF induces an accelerating force on an electron. What is the nature of this force? Basically there are two methods of producing an EMF. One is by subjecting the conductor to a fluctuating magnetic field or by having the conductor cut through magnetic lines of force. The result is the same. The other is by exposing the conductor to a difference of potential such as connecting it to the opposite poles of a battery. In this case one pole has a negative charge while the opposite pole is positive. The flow of electrons is the result of an electron concentration at one point tending to flow to an area where there is a shortage. The EMF is produced by direct electrostatic force, which in turn is of a dual nature. There is the tendency for negative charges to be attracted to positive charges as well as the mutual repulsion of negative charges. The voltage attained is directly proportional to the difference of potential existing between the poles of that battery. The difference of potential is equal to the kinetic energy gained by the electrons in moving from one potential to the other.

The EMF produced by a fluctuating magnetic field gives the same results but the process is different. When a conductor is subjected to

a fluctuating magnetic field, as with the secondary of a transformer, the "free" electrons of the conductor and the outer electrons of the atoms which are not as intimately associated with the atoms are exposed to differential ether bombardments. It is equivalent to an electrostatic force. When a magnetic field changes, the change does not take place simultaneously throughout that volume of space occupied by the field. It progresses from one portion to another. This creates differential electrostatic ether particle bombardments on electrons within the field. When a conductor cuts magnetic lines as with an AC generator, the electrons are subjected to the same conditions experienced by electrons moving between the poles of a magnet described in Chapter 11. The accelerating force will be in a direction perpendicular to the direction in which the electrons in the conductor are found to move.

If there were even a small fraction of the free electrons existing in the matter as is believed by our physicists, the negative charge effects of matter would be so great that these bodies would be unable to get close to each other. Much of the charge on condensers comes from outside the condenser, as is the case with the flow of electricity in conductors. Actually, free electrons in a conductor are practically non-existent. Hard electrons which are not a part of the atoms are captured by soft particles which permeate matter. The soft particles release hard electrons when subjected to the EMF in a current, or the voltage across the plates of a condenser.

The current in a straight wire is evenly distributed along the surface where the electron flow encounters the least resistance. The released hard electrons that are directly affected by the EMF tend to move as a unit partially held together by mutual magnetic attraction. This unit leaves a temporary void behind it which is quickly filled by surrounding hard electrons. Many such groups are started almost simultaneously in a conductor at about the speed of light, although the electrons, themselves, travel at a much lower velocity. When an EMF is applied to a conductor, something akin to the domino effect is set up in the ethers. This effect travels at the speed of light since it is produced in a similar manner.

The source of electricity flowing in power lines as well as that produced by generators comes from soft particles which permeate and surround the area has been proven during auroral displays. When aurora activity is unusually high, large transformers in Canada have been known to burn out and even explode. At the same time,



increase of current flow in power lines has been great enough to trip circuit breakers as far south as Texas. As explained earlier, the concentration of soft electrons in the atmosphere is greatly increased during auroral phenomena. Some areas, of course, receive much higher concentrations than others at the same latitude.

A loop of wire, or coil, offers impedance to an alternating current. This property of loops or coils is known as inductance. Since a single loop of wire has inductance, it follows that it can be explained in terms of one loop.

Electrons tend to travel along the surface of a conductor. This is the path of least resistance. The major source of this electricity is the high concentration of soft electrons that gather around a conductor and permeate the material. This is due to the relatively high positive charge of the conductor. The greatest concentration is found at the surface and a short distance below the surface. When an EMF is applied to the conductor, free electrons are set into motion. During this process, soft electrons concentrated at and below the surface tend to disintegrate and release more hard electrons. This is enhanced by the concentration of soft electrons, which in turn causes an agitation of the soft particles which causes them to become highly unstable.

In a straight wire, most of this disintegration and nearly all the electron flow takes place below the surface. This condition greatly shortens the mean free path of the electrons and the flow stops immediately after the applied EMF is shut off. Consequently, an alternating current will encounter the same ohmic resistance in a straight wire as will a direct current. However, the situation is different when the conductor is looped.

When an EMF is applied to a loop, the free or released hard electrons below the surface are forced to the outside by centrifugal force, whence a still greater disintegration of soft electrons occurs because the greatest concentration is at the surface. The mean free path of the electrons is greatly increased and the flow continues for a brief period after the EMF traveling in the direction of the flow ceases. When the EMF continues in the opposite direction, as in the case of an alternating current, the force must oppose the momentum of the electron flow in the direction opposite to that of the applied EMF. The explanation of the impedance or inductance that a coil offers to an alternating current is now apparent. It follows that this impedance will be directly proportional to the number of turns and to the fre-

quency of the AC. It is logical to assume that the deceleration rate of the electron flow is a constant when the EMF is zero. This means that the more quickly the EMF is applied in the opposite direction of flow, the higher the velocity of flow that will be encountered. It will be a linear function.

It would now seem evident that when the AC is rectified or has been changed to a pulsed DC, the coil will produce an increase in amperage where a straight wire will not. Experiments have proven this to be the case. It was found that the input amperage of a current was greatly increased after it passed through a coil. The increase was greatest during the initial stage of the applied EMF and soon dropped to a lower value as the concentration of soft electrons around the wire was reduced. It follows that a coil will offer impedance only to an AC current! It follows that pulsed DC has numerous advantages over AC. It can be used to operate transformers as well as AC without suffering impedance. Also ultrahigh frequencies for certain frequencies can be used that would be impossible with AC. These are facts that Tesla apparently overlooked.

A steady direct current experiences the same resistance in a coil as it does in a straight wire of the same length. The fluctuating EMF produces extreme agitation of the soft electrons around and inside the wire resulting in the disintegration of a high percentage of them, and the release of a high concentration of hard electrons. This does not occur during the flow of DC. There is more of a flow outside the wire where less resistance is encountered. This is offset by the fact that it requires more force to divert the electrons from their tendency to flow in straight lines. During the initial application of the DC, there is a surge of additional current during the build-up of the EMF for those reasons already given. When the current is shut off, there will be a momentary surge of current in the opposite direction. The excess of electrons, on the surface of the conductor and in the coil, will naturally flow toward the void outside the coil and in the opposite direction to which the current was flowing. The concepts just outlined can be applied when building a self-sustaining electric generator, which will be presented in Chapter 21.

When an alternating current is applied to a coil, the EMF must overcome the impedance each time the EMF changes direction. The greatest amount of resistance occurs at the beginning of each change, and steadily decreases as the current builds up. The resistance will be at a minimum when the current reaches its maximum.

This is because the EMF changes direction more frequently and encounters the maximum resistance for a higher percentage of the time.

The magnetic characteristics of a solenoid will now be explained. The flow of electrons in a wire results in a circular magnetic flow around that wire. As mentioned previously, the magnetic effects between electrons moving together tend to cancel each other out. They are drawn together and the resultant ethers, or magnetic flow, encompass the entire group. This also occurs between adjacent wire segments in a coil. The magnetic effects are canceled out between the segments and a continuous ether flow, encompassing the entire coil, perpendicular to the direction of the current flow, will result. The solenoid then will behave like a bar magnet with continuous lines of force moving into one end and out of the other.

The Earth's atmosphere produces geomagnetism in much the same manner that a solenoid produces a magnetic field. Charges in the atmosphere move along with the Earth in a circular motion. Although there is little motion of the charges relative to the surface, a magnetic field is still created. Magnetic lines, or ethers, flow from the south magnetic region to the north magnetic region as the result of these rotating charges.

## SUPERCONDUCTIVITY

Until the late Fifties, the phenomenon of superconductivity was considered one of the great unsolved mysteries. Then three physicists, Bardeen, Cooper, and Schrieffer, came up with a "theory" that allegedly resolved the anomaly. According to the accepted viewpoint, an electric current moves through an ordinary conductor as a stream of electrons flowing through a fixed crystal lattice. Electrical resistance results when, from time to time, the electrons smash into the lattice losing energy. In a superconductor, according to this theory, a strange (and inexplicable) thing happens. The electrons become attached to each other, and instead of traveling one by one, they travel in pairs and become mirror images of each other so that when one bangs into a lattice, the second ricochets, regaining the energy the other one lost. The net result is that the pair neither gains nor loses energy as it travels through the conductor. As is usually the case with modern

theoretical physicists, the theories they project pose greater mysteries than the one they are trying to resolve. By what strange process do electrons suddenly violate all the rules of electrostatics and become attached to each other in pairs as soon as they encounter a superconductor? To compound the outrage, they brought quantum mechanics into the picture with a mathematical monstrosity consisting of vague and inexplicable descriptions. They were awarded a Nobel Prize and showered with nearly every scientific honor for this speculative malfeasance. It has become more than evident the probability of a legitimate theorist existing among academic physicists is about the same as that of finding a female celibate in a red-light district. Their theories have about as much to stand on as a sky diver whose chute has failed to open.

The recent discovery of ceramic materials that exhibit superconducting properties at considerable higher temperatures than previously known materials, has created considerable excitement throughout the scientific world. As to be expected, attempts to explain the phenomenon have been pathetic. These substances, allegedly become superconductive at temperatures up to  $90^{\circ}$  above absolute zero or at about the temperature of liquid nitrogen. This necessitates a deeper look at superconductivity than has been given before by the author.

One of the necessary conditions for superconductivity is that the flowing electrons encounter no resistance or that equivalent to a flow in a vacuum! This means the electrons encounter no air molecules or the molecules of the conducting material. A powerful clue toward understanding what is taking place is the fact that a disc of the material can be cooled down to the temperature of liquid nitrogen and then a small magnet placed over the disc will remain suspended. This means that the current induced in the disc by the magnetic field produces a field that repels the magnet. In order for the current to start, a repelling force must be exerted on the free electrons comprising the flow. This is supplied by the electrons captured by the magnetic field. It is significant that the small magnet must be inordinately powerful. Since the magnetic field produced by the induced current is strong enough to propel the magnet upward, it follows that the amperage is enormous. Another important fact is that the ceramic molecule consists of several metals in combination with an oxygen atom. This produces a molecule that has a tremendous affinity for soft electrons. The picture is now becoming clear. A material with a strong affinity

for soft electrons coupled with the low surrounding temperature means a potentially powerful sink for soft electrons since low temperatures cannot exist without a shortage of soft electrons.

The electrons initially set into motion along the surface of the conductor initiate a chain reaction with an inordinate flow of surrounding soft electrons to the areas as a result of the combination of conditions just mentioned. This produces an abnormal disintegration of soft electrons releasing the hard electrons which constitute the flow. Since the flow follows circular paths, practically the entire flow is on the surface of the ceramic. They could not flow inside without bombarding the molecules. Also, the electron flow tends to encounter near vacuum conditions on the surface due to the ultrahigh soft electron concentration tending to dematerialize air molecules. They have little tendency to capture the hard electrons because of their rapid motion.

It follows from the above analysis that the essential difference between conductors which exhibit superconductivity only at temperatures near absolute zero, and those who have it at higher temperatures, is that the latter have a higher affinity for soft electrons. There still remains a few unanswered questions. For example, why is it that some materials which are not good conductors at room temperature become superconductors while others that are good conductors at normal temperatures never become superconductive? An important fact to consider is that electron flow in the case of superconductivity is entirely on the surface of the superconductor. Since a poor conductor does not permit an easy flow of electrons in its interior, there is a tendency for any flow to occur only on the surface. Soft electrons having a high affinity for good conductors, have a tendency to enter the conductor when there is an ultrahigh concentration near the surface tending to release hard electrons within the material. This tends to disrupt the electron flow at the surface. Consequently, metal conductors must be near absolute zero for so-called superconductivity to occur since at such temperatures a greater sink for the flow of soft electrons and electrons at the surface is produced.

The famous Meisener effect shows that electron flow in superconductivity is exclusively outside the conductor. Meisener discovered in 1931 that magnetic fields do not penetrate below the surface of conductors in the superconductive state. This is actually a confirmation of what has already been stated. The magnetic field



produced by the electron flow will repel any external field. What Meisener and others failed to realize is that any external field applied to a superconductor immediately sets up a current at the surface that produces a field which repels the applied field. Although the magnetic field is extensive outside the surface, it paradoxically does not extend below the surface. This means that the bulk of the electron flow is well above the surface of the conductor. This is to be expected because of the tremendous influx of soft electrons from surrounding areas. Soft electrons which concentrate at the surface repel incoming soft particles producing a turbulence that releases hard electrons well above the surface. It is not surprising that "explanations" of the Meisener effect are extremely vague and meaningless. It also becomes evident so called superconductors are in reality non-conductors.

Scientists are excited about the possible applications of the new "superconductors". However, they can all be obviated by the devices analyzed in Chapter 21.

## CHAPTER 17

# PECULIAR AND UNEXPLAINED ANOMALIES OF NATURE

## THE PROPERTIES OF HELIUM AT LOW TEMPERATURES

Helium at low temperatures exhibits strange properties which have never been explained by science. The assertions of quantum mechanics experts are contrary and highly misleading. They have never explained anything satisfactorily, despite all of their vaunted claims. Such efforts are no better than the practice of tacking a name on some phenomenon and thereby claiming that it has been explained.

Liquid helium below 2.2 degrees Kelvin is known as helium II. It demonstrates the characteristic of superfluidity at such temperatures. It readily passes through extremely narrow slits and capillaries with no evidence of retardation in the process. The well-known "creeping film" effect is displayed when it is in this condition. The liquid tends to climb up the walls of a container and if that container is not partially submerged in a liquid helium bath, it is soon emptied.

Helium I also shows dualistic properties. It will deflect vanes submerged in a moving liquid while demonstrating superfluidity, or a lack of viscosity, at the same time. Yet, the deflection of the vanes indicates that there is viscosity. These and other paradoxes of helium actually demonstrate the validity of some of the principles already introduced in this treatise.

The interactions of protons and neutrons in the nucleus of helium result in greater activity of the protons, with the consequent transformation of a greater portion of their electrostatic potential into magnetic fields. The number of protons and neutrons in the helium atom is the optimum number for the greatest amount of proton activity. As a result, the net positive charge of helium extends farther beyond the electron zone of activity than normal and is consequently weaker. Therefore, helium has little tendency to combine with other

atoms. The zonal effects practically disappear when helium is reduced to temperatures below  $2.2^{\circ}$  K, because none of the soft electrons produced by interactions of the fundamental particles are disintegrated by thermal agitation of the molecules. This results in higher negative charge effects throughout the mass. Helium atoms have no affinity for each other in this state, and helium at  $0^{\circ}$  K will remain a liquid unless it is subjected to high pressures.

The near absence of zonal effects means that the negative field around the atoms extends for greater distances. This readily accounts for the creeping film effect. Since the walls of the container holding helium II behave like a positive charge, the helium atoms acting like negative charges under these conditions will distribute themselves over the walls in a manner similar to that of a conductor. If the container is out of the bath, the mutual repulsion of the atoms will cause nearly all of them to be ejected from the container, since the repulsions are stronger than their affinity for the sides of the container. There is, however, a weak positive field which exists a considerable distance beyond the confines of the atoms of helium II. This and the almost complete absence of kinetic energy of the individual atoms enables helium to remain a liquid. The overall positive charge also enables helium II to be affected by gravity.

Some of the molecules of helium II have appreciable velocities at any temperature above absolute zero or  $0^{\circ}$  K. Such atoms have magnetic fields around them. This completely resolves the mystery surrounding the dual properties of helium II. The helium molecules of low velocity display the superfluidic effects, while at the same time the molecules with the higher velocities have stronger magnetic fields around them. These higher velocity molecules interact with the outer molecules of the vanes immersed in the liquid causing them to be deflected. It is to be expected that the portion of helium II which passes through narrow slits and capillaries is at a lower temperature than the rest of the liquid. This has been confirmed. Here is an actual demonstration of Maxwell's demon separating the low velocity molecules from those of a higher velocity!

Helium II exhibits a property which even the quantum mechanics experts surprisingly admit they have no means of explaining. The superfluidity of helium II is lost if it is allowed to flow too rapidly. When helium has a rapid flow, significant magnetic fields develop around all the atoms which are extremely feeble, but are strong enough to produce interactions with each other and with the mag-

netic fields generated by the kinetic energy of molecules of other substances. This consequently destroys superfluidity. It should be kept in mind that the magnetic fields, due to the thermal agitation or motion of the helium atoms, are similar to the magnetic fields produced by the motion of the atoms of other substances. This fact makes the interactions possible. Superfluidity is a very delicately balanced condition which is easily upset.

An isotope of helium, called helium III, having fewer fundamental particles, produces fewer soft electrons than normal helium. In addition, the presence of fewer particles in the nucleus causes the protons to be less active. As a result, helium III has more pronounced zonal effects around the atoms, and, due to this fact, it was not expected that helium III would exhibit superfluidity at any temperature. This has since been proven to be the case. There is an optimum number of particles in the nucleus of the helium atom which produces the greatest proton activity. If that number is high, the protons are restricted and mutual repulsion cancels out. If the number is low, the interactions are greatly reduced.

## **"MYSTERY SPOTS" INCLUDING THE FAMOUS OREGON VORTEX**

There are a number of well-known areas called "mystery spots" or "magnetic anomalies", where unusual phenomena occur and nature's laws are said to have gone awry. The best known of these is called the Oregon Vortex, located near Gold Hill in southern Oregon. It is situated near the fault line which runs along the West Coast, and still another vortex in southern Oregon and one in southern California. The following analysis will be restricted to the Gold Hill, Oregon Vortex. Most of the peculiarities of this particular vortex are confined within an area 165 feet in diameter. Within this area, sudden changes in a person's height seem to occur. It is also significant that gravity effects fluctuate within that area. Gravity may be as much as ten percent below normal in some cases. This means that a 200 pound man would weigh only 180 pounds.

These phenomena do not occur uniformly within the vortex area, but follow lines or tubes which run north to south and east to west. These lines or tubes are called terralines and are about five feet

wide. They also seem to exist outside the vortex area, in a regular grid pattern covering many thousands of square miles. However, the effects of these terralines above the surface are more pronounced and warped within the vortex. Smoke blown in the path of a terraline tends to move spirally along the terraline. A pendulum consisting of a heavy iron ball suspended by a chain swings abnormally when the direction is along the terraline. The swing is much longer in one direction past the point of rest than it is in the opposite direction. A broom inside the vortex stands upright with little persuasion. Everything in this area, including the broom, tends to lean toward magnetic north.

According to John Litster, in a pamphlet entitled *The Oregon Vortex*, the vortex area expands and contracts periodically. He also indicates that although the terralines outside the vortex do not oscillate, the portions which intersect the vortex do. The following passage is taken from this booklet on page 3: "The lines within the area move, or oscillate, with a period of 22.329 seconds." Litster failed to divulge his method of determining this period to such a degree of refinement. Atomic clocks weren't readily available at the time he wrote the booklet.

A valid explanation for the vortex will now be presented. The vortex and terralines consist of beams of soft electrons traveling at very high velocities. Figure 23 illustrates the phenomenon. The types of particles cover a wide range with a significant percentage comprised of high frequency photons in the upper ultraviolet range. The conclusion that they have a high velocity and a wide range of frequencies is the only way to account for the phenomena observed.

The apparent sudden increase in size when a person walks from one region to another is due to refraction effects of light. Photographs verify this effect. This is the only explanation offered by scientists for any of the phenomena observed which shows any degree of rationality. Of course they are somewhat vague as to what produces the refraction effects. It is the ultrahigh concentration of soft particles and the associated variations in their intensity resulting from the terralines and the main vortex shell which cause the light rays to bend. When light encounters a terraline, it is refracted and lens effects are produced. The beams of soft particles contain a high percentage of particles which are comprised of photons whose frequency range is not far removed from the photons of visible light. The distribution of particles in these beams is such that the bending



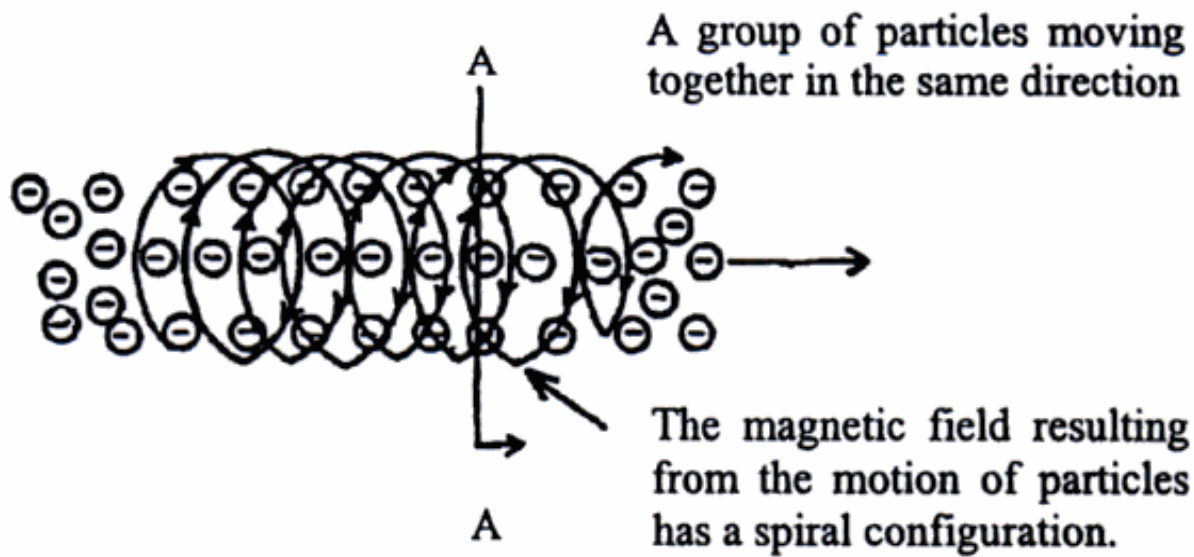

Cross Section A-A



Particles have a tendency to travel down magnetic lines. Individual particles of a large group tend to follow a path which forms a spiral or vortex. The vortex motion follows the left hand rule for negative charges.

The Oregon Vortex

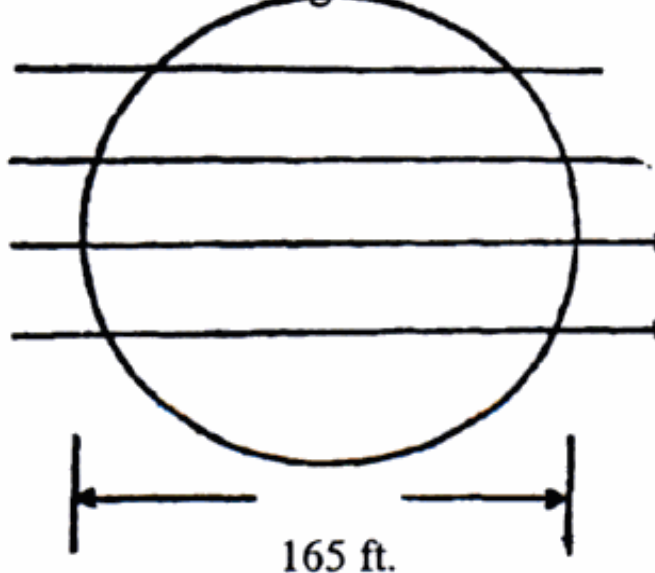

The Oregon Vortex consists of a great beam of high velocity soft electrons emerging from the Earth. Terralines consist of smaller beams of soft electrons which intersect the main vortex and travel parallel to the earth. Smoke and small bits of paper tend to move upward with the stream of emerging particles in a vortex motion.

FIG. 23. THE OREGON VORTEX

of light rays is not sufficiently abrupt to indicate the outlines of the terralines or the changes in intensity.

When an object enters the vortex, it immediately becomes impregnated with these soft particles. This reduces the weight to some extent, because of the reduction in the overall positive charge. Another factor contributing to the weight reduction is the bombardment of high speed particles, flowing upward in opposition to the Earth's gravity. Two of the well established phenomena have now been accounted for. Several more aspects remain. Objects in some parts of the vortex tend to roll uphill. This is due to a terraline running parallel to the ground. The bombardment of the particles produces a force on the object in the direction of flow. This is also responsible for the behavior of pendulums or plumb bobs in some parts of the vortex. The direction of swing is along a terraline. The swing in one direction is moving with the flow, while in the opposite direction the bob or pendulum moves against the flow. This effect is enhanced by the fact soft electrons have a tremendous affinity for metals. The metallic ball at the end of the chain concentrates a high percentage of the flow along the terraline to the ball such that it receives a much greater bombardment than would a non-metallic ball of the same size.

The flowing soft electrons by themselves would produce little if any force. It is the hard electrons they periodically release and also which are not entirely camouflaged bombarding the atoms and molecules of a body which produce the force. This is something akin to the photo-electric effect explained earlier.

The force of bombardment of these high speed particles is demonstrated when smoke is blown into the vortex or terraline, or when small pieces of paper are released. They tend to move around in spirals, traveling down terralines and moving upward in the vortex, as though they had encountered a whirlwind. This phenomenon is responsible for the term "vortex" being applied to the area. A flow of the charges assumes a vortex pattern. This is due to the configuration of magnetic fields resulting from the motion of these charges. The magnetic field, as previously mentioned, assumes a corkscrew motion. This corkscrew pattern of magnetic fields is the pattern for the general motion of these particles as a group, since these particles have a tendency to move down magnetic lines of force. It will be noted that this vortex motion will follow the left hand rule since the particles are predominately negative.

The author does not know whether magnetometer measurements have been made in the area. It is probable that they would show a substantial increase in the Earth's field since standing objects tend to lean toward magnetic north, indicating a strong, concentrated field. This is in accordance with the principles of terrestrial magnetism. The tendency to lean toward magnetic north is a result of the increase in the Earth's field and, more importantly, that objects placed in the vortex are saturated with soft particles. This renders the body more susceptible to the Earth's field since the particles occupying the body tend to travel down magnetic lines of force toward the north. There is little tendency to fall over because of the tremendous bombardment of particles moving up from the ground, which accounts in part for the gravity reduction. It also explains why a broom in the area can be made to stand upright without support. It has been noted (and the author has confirmed it) that the weight of a body at a given point fluctuates over a period of time.

The behavior of these terralines, at the point where they intersect the vortex, and the tendency for the network to assume a hemispherical shape, is also to be expected. The influence and bombardment of the great flow emanating from the ground forces the terralines upward and distorts them at the same time. The lines are moving in a horizontal direction while the vortex moves in a direction perpendicular to them. The concentration of the charges in the vortex should increase from the outer edge toward the center. This pattern would produce a displacement of the terraline network in a hemispherical configuration.

It is probably apparent to the reader at this point that phenomena observed in the vortex confirm principles and concepts already discussed. All that needs to be done now is to account for the origin of the energies in the vortex. A powerful clue is already at our disposal. The intensity of the energies in the vortex greatly lessened immediately following the great Alaska earthquake of 1962. A broom could no longer be made to stand upright. Whether or not the terralines were affected is not clear. It was not until some time later that the vortex resumed its old behavior. This seems to eliminate the possibility that some manmade device placed underground in the distant past is the cause.

The apparent conclusion is that the vortex energies are somehow connected with the bombardment of energies from the Sun. There are great fault lines in the region of Alaska and the Aleutian Islands

which have also been a region of great volcanic activity. The solution is not difficult considering the discussion of the origin of earthquakes and related phenomena. It is possible that the alternate charging and discharging of energies in underground faults creates the oscillatory pattern. The presence of giant underground caverns may also contribute to the periodic discharge of soft particles through certain relief points on the surface. The discharged particles are readily conducted away by underground channels, which come close to the surface in the vortex area. Apparently, the entire Earth pulsates in response to the cyclical pattern of the Sun, much like the nature of the fundamental particles. The 2nd Hermetic Axiom necessarily connects the phenomena.

Many scientists have visited and studied the area over a long period of time. A variety of theories has been advanced by them to explain the phenomena. As the reader should expect by now, such theories have varying degrees of merit, ranging from the idiotic all the way on up to the moronic.

The most recent attempt to explain away the phenomena in the Oregon Vortex was described in an article entitled "Magic Man," by Scott Morris, in the May 1981 issue of *Omni* magazine. The protagonist of this article was the famed magician Jerry Andrus. As a master of illusion, Andrus has no peers among his fellow magicians. He is able to create illusions that baffle all of his colleagues. Recently Andrus and Morris visited and studied the phenomena in the Oregon Vortex. The final conclusion of this illustrious gentleman was that the phenomena of the vortex were illusions and nothing else.

To support this conclusion the author apparently falsified some of the findings. Consider the case in which the height of an individual suddenly changes when he moves from one area to another. There is a line of demarcation at which the change is instantaneous when that line is crossed. A plank is centered on one of these lines. When a camera is placed so that it is centered between the two ends and at right angles to the base line, it will definitely record a change in height of at least four inches when a person moves from one end of the plank to the other. The pamphlet, *The Oregon Vortex* by John Litster, shows a series of photos which prove that this phenomenon is real. One can measure the change from these photos. Perhaps the most interesting of these photos is that of three levels placed at the line of demarcation. Two are in a vertical position a certain distance



apart at their bases and the other is in a horizontal position. According to the bubbles, they are all level, yet the ends of the vertical levels appear to be (and measurements confirm this) farther apart at the top than at the bottom, and according to the photos, they are also wider at the top. They appear to be badly warped.

It is highly significant here that the apparent change in size is not readily apparent when viewed from all directions and under the same conditions in any of these areas. This shows that the phenomenon is produced by light being refracted as it passes from an area of high soft electron concentration to one of a lower concentration or vice versa. This produces what is known as a lens effect.

According to Scott Morris, his camera did not show a change when it was placed in the manner described above. He did mention the heavy weight suspended from a chain. From its normal position at rest, as described earlier, it definitely swung further in one direction than it did in the opposite direction. It does require less force to move it in the direction of greater swing than in the opposite direction. This author personally confirmed this. Yet Mr. Morris denied it. He stated that the force required was the same in each case. Andrus and Morris ignored other significant facts such as the broom standing without support, which at the same time leans away from the vertical. This was determined by a plumb bob, the change of weight in various parts of the vortex, the strange curving of Madrona trees where they come in contact with the terralines, and other phenomena.

The author wrote *Omni Magazine* and stated that Morris had lied. Very shortly this writer received a registered letter from Morris threatening to sue the author and demanding an apology and also proof the phenomena in the vortex is real. He stuck by his statements while at the same time averring his personal integrity. The author responded immediately with photographic proof and he made statements to the effect Morris' letter convinced him still more that he is indeed a liar. The author never heard from him again.

At this point it should be emphasized again and again, Morris' and Andrus' reaction is not unique in regard to the vortex or any phenomenon when academic trained minds are exposed to such things beyond their comprehension. An older brother steeped in the academic tradition reacted in even a more irrational and less than admirable manner when he visited the Oregon Vortex. When confronted with the photographic proof he insisted the photos were faked.



This illustrates once again the devious tactics to which many individuals will resort in order to support their pet dogma, and that they will conveniently ignore certain facts that are a major threat to that dogma and often difficult to explain away. No doubt Andrus is a very clever man along certain lines of endeavor, but his cleverness seemed to desert him when he was confronted with facts outside his domain. How often has this pattern been repeated among the members of the scientific community? It seems that lack of intellectual integrity is not confined to this group. Ultimately, it is left up to the reader to decide to which portion of the scale mentioned above the Morris-Andrus theory of the Oregon Vortex belongs.

## GRAVITATIONAL ANOMALIES

There are a number of little publicized gravitational anomalies which seem to refute the Newtonian and Einsteinian dogmas. One of the most baffling of these is that the force of gravity over oceans and large bodies of water is greater than over land masses. In addition, the deeper the water, the greater the force. This is the opposite of what should be expected. The new concept of gravity easily resolves this paradox. Water contains high concentrations of soft electrons of all kinds, some of which correspond to the lower infrared range, and are not far removed from the gravity range. These soft electrons are more readily affected by gravity radiations and many of them tend to be repelled and move upward in the same direction as the gravity radiations. Some of the photons associated with the gravity radiations attach themselves to the trailing portion of these very soft electrons. This promotes a slight nullifying effect on the negative charge effects on that trailing portion of these particles. This enables some of the soft electrons in the lower infrared region to produce weak gravity effects in addition to the normal gravity. The result is higher than normal gravity over oceans than over land masses.

The behavior of matter ejected by explosions on the Sun's surface defies all of the popular laws of gravity. This matter occasionally rises to altitudes of several hundred thousand miles. It does not follow a trajectory in descending as it is supposed to. Also, its speed of descent does not follow the law of falling bodies at any time. In fact the velocity of fall is much lower than should be expected. One of

the reasons is the low surface gravity of the Sun. Another reason is the variable quantity of negative charges which impregnate these masses.

On occasion, large hailstones have been known to fall much more slowly than the conventional law of gravity would allow. It is extremely significant that after they hit a roof, the rate of descent greatly increases. From what has been shown, the explanation is obvious. The hailstones formed during an abnormal concentration of orgone energy in the atmosphere. As a result, the hailstones contained a higher than normal concentration of negative charges. After hitting a roof, many of the negative charges would be jarred loose.

## **THE ORIGIN OF THE VAN ALLEN RADIATION BELT**

The Van Allen Radiation Belt consists of high concentrations of charged particles and is centered around the Earth's equator. It has a crescent shaped cross section. The upper fringes extend to about 60° north and south latitude. The lower limits of the inner portion are several hundred miles above the Earth's surface. The outer portion extends to about 28,000 miles above the Earth. The highest concentration of charges is in the inner portion at an average distance of several thousand miles above the Earth. It is confined to the lower latitudes. Figure 24 depicts the Van Allen Belt.

As usual, the conventional explanation is totally misleading. The claim is that the Van Allen belt consists of electrons and protons, which are captured by the Earth's magnetic field. This shows the usual bad logic. Particles captured by a magnet have their greatest concentration around the poles. The opposite is the case here. Also, if they were captured by the Earth's field, why are they so far above the Earth? If geomagnetism were produced according to conventional theory, its highest intensity would be close to the Earth's surface. Therefore, the Van Allen Radiation Belt, instead of being a great distance above the Earth, would concentrate near the surface, if its presence were due to particles captured by the Earth's magnetic field.

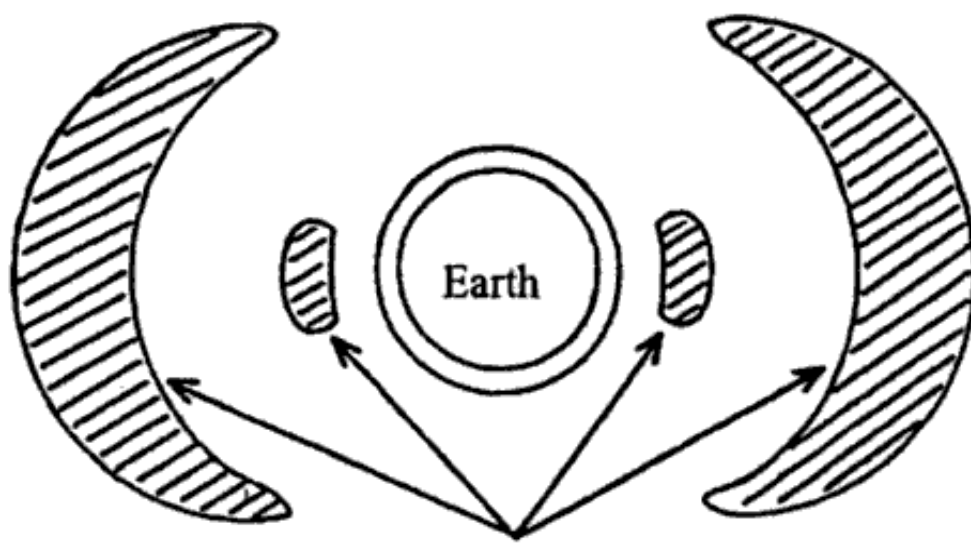

Zone of highest concentration  
of electrons and protons

*FIG. 24: THE VAN ALLEN RADIATION BELT*

*The position and distance of the Van Allen Belt from the Earth demonstrates that the particles are not captured by the Earth's magnetic field.*

Since the Van Allen Radiation Belt does not consist of charges captured by the Earth's magnetic field, why do they assume the configuration of the belt? Nearly all of the particles in the belt are particles which have been ejected by the Sun. These particles consist mainly of soft electrons of various kinds. Their penetrating ability, as is indicated by their effects upon satellites, have given the false impression that they are high energy particles. Soft particles which penetrate solid matter release hard electrons and protons in the process. It was assumed that these hard particles could only have penetrated matter if they had extremely high initial kinetic energy. The Earth's magnetic field must be already saturated with particles since its field is of limited intensity and can capture no more. Additional particles coming in tend to be repelled by the field back toward outer space. The highest concentration of particles in the Earth's field is in the higher latitudes. Therefore, the greatest repulsive forces must

exist in that region. That is why the belt is concentrated closer to the equator.

Cosmic dust, which permeates all of the space occupied by the physical universe, plays an important role in the formation of the Van Allen Belt. Were it not for the presence of these dust particles, the Earth's gravitational field would prevent a belt from forming around the Earth. Particles ejected by the Sun tend to lose much of their initial velocity due to collisions as they approach the Earth. The lower velocity, negatively charged particles tend to collect around dust particles, which have a net positive charge. This produced a neutralizing effect by which the combination is neither attracted nor repelled by the Earth's gravitational field. Charges with a much higher velocity reach the Earth and penetrate it. This neutral combination is not stable and particles are continually being dislodged from dust particles by collisions with other particles. The lower portion of the radiation belt encounters the zone of particles captured by the Earth's field. This is one reason that it does not get closer to the Earth. The presence of the cosmic dust enables a very high concentration of these particles to be near the center of the belt.

Many of the soft particles permeating the cosmic dust tend to dematerialize it. This accounts for the dust which always collects on completely enclosed surfaces in a supposedly dust-free atmosphere. When the dematerialized dust encounters a surface, some of the dematerializing energies tend to be drawn out or disintegrate, leaving materialized dust on the surface.

## CHAPTER 18

### NEW INSIGHTS INTO THE RESEARCH OF WILHELM REICH

Wilhelm Reich is one of the few men in this century who is completely worthy of the appellation "scientist". His contributions to various fields of science are staggering. He has been pilloried by the world of science for his efforts. His persecution by members of the AMA, its henchmen in the U.S. Government, as well as some others eventually brought about his demise in a federal prison in 1957. Although his books were burned by government agents, fortunately most of his work escaped their attention, and some of it is now being reprinted. This chapter is mainly concerned with Reich's research on what he termed "orgone energy" and related phenomena. As will be shown, his discoveries in this field are a marvelous confirmation of principles upon which we have already elaborated. In fact, the author has learned about some of the more important details of Reich's experiments after much work had already been completed on this book.

#### ORGONE ENERGY, BIONS, AND SOFT ELECTRONS

Reich first became aware of a mysterious radiation he later called "orgone energy" while experimenting with bions. Reich's definition of a bion, taken from his book entitled, *The Cancer Biopathy*, on page 15, is as follows:

*Bions and energy vesicle designate one and the same microscopically visible, functioning formation. The term "bion" refers to vesicles into which all matter disintegrates if made to swell. These vesicles represent transitional forms between non-living and living matter. The bion is the elemental functioning unit of all living matter*

He even produced bions by heating substances to incandescence such as coal, earth crystals, and ocean sand, and then subjecting them to chemicals which induced swelling in completely sterile containers. Living matter such as bacteria emerged from these sterile preparations! This, of course, violates all orthodox biological



concepts, and was one of the discoveries which led to Reich's persecution.

Reich experienced a tendency for his eyes to smart while examining bions under a microscope. The longer the period of observation, the more his eyes hurt. In the *Cancer Biopathy*, on page 86, one of his experimental subjects exposed to the same radiation stated, *I feel as if I had been staring in the Sun for a long time*. This energy also fogged photographic plates through shielding. In a dark room, the bion cultures emanated blue and violet light. The room also became saturated with these energies, and it seemed to come from the walls and objects around the room. This energy even produced a reddening of the skin like a sunburn. A deep tan eventually developed over the entire body under constant exposure, although there was no exposure to the Sun.

Reich later performed experiments with electroscopes in the presence of high concentrations of this energy. He put on a pair of rubber gloves which had been exposed to the Sun. When he moved his hands toward the electroscope, there was a strong deflection of the leaves. The rubber gloves had not been charged in a conventional sense. When the gloves were placed in the shade for a time in the open air, they no longer influenced the electroscope. It is extremely significant that after the gloves had been exposed to the Sun, they influenced the electroscope again! Other objects, such as paper, cotton, wool, etc. exposed to the bion cultures, also influenced the electroscope. This was also the case when an organic substance was placed in contact with living tissue, such as the human body. The more active or healthy the individual, the greater the resistance on the electroscope. It is also significant that when the electroscope was exposed directly to the radiation from the bions there was no reaction.

Reich later found this energy was everywhere, but in varying concentrations. It would readily penetrate everything, including lead shielding, but was more easily absorbed by organic and non-metallic substances than by metal. He built orgone accumulators consisting of boxes with alternating organic and metallic material for its siding. He also found the immediate source of this energy was the atmosphere, which in turn, received it from the Sun. The concentration of energies in these boxes, or accumulators, depended on the time of day and weather conditions. The concentration was at its lowest during the night. It was somewhat lower on cloudy days than on clear days.

The nature of the energies with which Reich was dealing is probably growing apparent to the reader from what has already been revealed. The greatest portion of the transformed energies from the Sun, reaching the lower levels of the atmosphere, is still in the lower ranges of the ultra-violet and the blue and violet part of the visible range. Much of the radiation is in the form of soft electrons, comprised of photons, in these frequency ranges. This is the orgone energy Reich discovered. The blue and violet light Reich observed in the dark room was the result of the more unstable of these particles breaking up into their constituent light. This is also the reason for the blue sky. The disintegration of soft particles in the atmosphere produces scattered photons moving in all directions. The concentration is much lower at night, and there is a lessened tendency for disintegration by collision with air molecules, since very little are being radiated from an external source. As a result, the sky becomes black. During the day, a lower percentage of the radiation from the Sun has been transformed into the lower frequencies in the upper atmosphere, according to the law of redistribution. Consequently, the photons of violet light outnumber the blue photons. This explains why the sky takes on a violet shade in the higher elevations.

It is also interesting that the sky is a deeper blue at the zenith than near the horizon. The radiation from the Sun is transformed into the lower frequencies at the lower elevations. Therefore, there is more visible light and a greater quantity of other light frequencies which tend to blend into white light, mitigating the blue. When one's line of sight is along the horizon, only the lower portions of the atmosphere are viewed where these transformations are taking place.

According to physicists, the blue results from the scattering of blue light by dust particles in the atmosphere. If this idea were valid, then all dust particles would have to be nearly uniform in size to be so partial to blue. This would be a most extraordinary coincidence, violating all of the rules of probability. At any rate, why doesn't the remaining light from which the blue was extracted create odd color effects? And why doesn't the spectrum produced by rainbows and prisms indicate a shortage of blues? Of course, there is the other difficulty in explaining the process by which light can collide with any particle and scatter only the blue light.

Reich's conclusion was that orgone energy is responsible for the blue sky, and he gave a logical argument to support this idea. He noticed on clear days distant mountain ranges and hills were blue. Yet,

right after a rainstorm or during extremely cloudy conditions, the blue disappeared. Most of the orgone energy in the atmosphere between the viewer and the hills had been washed away by the rain or absorbed by the clouds. As was pointed out earlier, soft electrons have a tremendous affinity for water. It is because of the orgone is absorbed by water. The blue is the light released by the disintegration of a portion of the orgone.

Before continuing with Reich's researches, the present trend of thought concerning the color of the sky in relation to the density of the atmosphere at or near the point of observation should be discussed further. If the quantity or density of Earth's atmosphere were to increase, it follows that the color of the sky would change from blues to colors associated with the lower frequencies. A point would soon be reached at which the sky would become yellow and the horizon would take on a saffron hue. Much of the blue of the lower atmosphere of the Earth is a mixture of the yellow and green. As the atmosphere becomes denser, the yellow, being lower in frequency, starts to dominate. It is highly significant that Howard Menger, in his book, *From Outer Space*, described such a sky on the Moon. (It was suggested in Chapter 1 that large areas on the Moon have considerably more atmosphere per unit area than is experienced any place on Earth). According to this book, Menger was taken to the Moon and allowed to walk around on its surface. All aspects of Menger's book have a ring of truth. They are in harmony with what the author knows concerning the subject matter discussed in the book. For example, Menger encountered a highly advanced alien known as a space master, who made the following statement concerning the nature of time: *There can be no time without motion, nor motion without time and neither without thought.* This is essentially the same definition already presented in this book, which the author formulated long before reading Menger's book.

There have been others prominent in the UFO controversy who claim to have been taken to the Moon and who became aware of earth-like conditions on the Moon. These include the late Buck Nelson and George Adamski. Their claims have all been in agreement with each other. In fact, as early as 1950, Buck Nelson claimed the Moon had Earth gravity. The author apologizes for this digression.

Reich's experiments with the electroscope demonstrated the nature of soft electrons and the nature of light presented earlier. They also demonstrated the presence of high concentrations of hard electrons

existing everywhere, camouflaged by softer electrons. It was shown earlier how soft electrons create electric currents in conductors and make other phenomena possible. Organic materials absorb large quantities of orgone energy and at the same time absorb significant quantities of hard electrons which are carried into the material by the orgone. This creates electrostatic field effects around the material, and hence strongly affects the electroscope. Since sunlight produced a similar charge on organic substances, it is apparent that light consists of negative charges, mostly soft electrons, moving with the photons. It has yet to be explained why the direct radiations from bions did not affect the electroscope. It has been shown previously that the intensity of the electrostatic field around a particle is directly proportional to the frequency of the light photons of which it is comprised. This means that the electrostatic field intensity around soft particles, or orgone energy, is only about 1/3000 of that around hard electrons. The direct radiation from the bions had little chance or time to absorb any hard electrons. Their effect on the electroscope, without the presence of hard electrons, was consequently minuscule. When they absorb electrons, their field effects are much greater, although they are still much less than if the hard electrons alone were present.

The more cogent reader may have become aware of another paradox by this time. It has been stated with complete justification that it is the soft electrons accompanying light which are responsible for the chemical changes produced by it, and not the photons. Yet, if a photographic film is covered, it will not be exposed even when subjected to direct sunlight, and the soft electrons accompanying the light readily penetrate the cover. This paradox reveals an important property of soft electrons in their promotion of chemical changes. However, it has not yet been satisfactorily resolved.

Chemical changes are expedited during the disintegration of soft electrons when they release great quantities of harder electrons. The normal field intensity around soft electrons alone is insufficient to promote chemical changes. When a film is exposed to direct sunlight, it encounters a large quantity of very unstable soft electrons which immediately disintegrate and release hard electrons. These hard electrons cause the film to be fogged. The more stable, soft electrons pass on through the material without interacting. The more unstable, soft electrons of light, impinging on shielded film immediately disintegrate at the shield.



Reich demonstrated that bions could fog photographic film through thick shielding. In this instance, the soft electrons emitted by the bions were stable enough to penetrate the thickness of the shield without disintegrating, yet insufficiently stable to go through the remaining film thickness intact. The film was, therefore, fogged. The reader may see by now why it is the soft electrons and not the photons which are responsible for the chemical changes produced by light. The range and combination of hard electrons housed by light are dependent on the frequency and hence the type of soft electrons accompanying light.

The demonstration by Reich and others of the seeming spontaneous generation of life from "inert" matter is in agreement with the principles introduced in the chapter on the Pyramid of Life which is to be presented in Part IV. All intelligences are potential creators in varying degrees, regardless of their position on the pyramid. This creativity manifests itself in projecting simple bodies into realms below that in which their creators exist. Reich's experiments in the creation of bions provided the ideal conditions for elemental intelligences, in a realm slightly above the physical, to start the projection of a body into the physical realm. Bions were the first step in this creation. It is expected that bions would generate high concentrations of these energies, since soft particles play a vital role in all of the life processes in this realm. This happened to be the frequency range Reich called orgone energy. These elemental intelligences are, in turn, created by a higher order of intelligence.

One of the characteristics of living tissues and organs is its ability to generate large quantities of orgone energy and other kinds of soft particles. This ability is considerably lessened in an impaired or unhealthy organ. Consequently, such organs have a higher positive charge than a normally functioning one. This is why orgone energy concentrates around these afflicted areas when an individual is exposed to this energy in an accumulator. This puzzled Reich since he was unaware of the true nature of orgone energy. Soft particles in relatively high concentrations are radiated by living tissues, thereby creating the aura seen around plants, animals, and people by sensitives and psychics.



## THE ORANUR EXPERIMENT

One of the most remarkable aspects of Reich's research was called the Oranur Experiment. He placed a small quantity of radium in an orgone accumulator with near disastrous results. A high concentration of what was called deadly orgone energy quickly permeated the area and spread to considerable distance beyond the accumulator. This energy produced all the symptoms of radiation sickness, and nearly killed Reich and his assistants. Reich's conclusion about the results of the Oranur Experiment is taken from his book, entitled, *Selected Writings*, on page 358:

*It was found, beyond any reasonable doubt, that so-called radiation sickness is not, as heretofore assumed, a direct result of NR radiation upon living tissue; but an immediate expression of a severe reaction of organismic OR energy against the action of NR radiation.*

He also found that when radium was placed inside heavy lead shielding, and this, in turn, was placed in a heavy safe, functioning as an orgone accumulator, unexpected results occurred in the radiation count. Although a Geiger counter showed an abnormally high count in the vicinity of the safe, the radiation proved to be harmless. When the radium was removed from the shielding and safe and tested in the open, the counter gave a relatively low reading.

Once again, all of the phenomena related to the Oranur Experiment are easily understood in light of concepts and principles already introduced. Radium supposedly emits alpha particles, which are helium nuclei supposedly made up of two protons and two neutrons. The deadly orgone energy consisted of abnormally high concentrations of soft electrons clustered around the positively charged alpha particles and also soft electrons that captured concentrations of protons. In other words, the difference between what Reich called deadly orgone and the normal orgone energy is that in the former case, the soft electrons housed predominately positive charges instead of negative charges. Positive charges and ions are inimical to living organisms. The harder electrons associated with gamma rays are also ejected and captured by the soft electrons. These particles are different from the hard electrons of normal electricity. They have no preferred direction of spin, and are relatively unstable and destructive. This combination results in considerable excitation and a high rate of

orgone disintegration with the sudden release of these particles within the living tissues.

Alpha particles are attracted to high concentrations of orgone energy. In turn, lower concentrations move in to fill the void when the higher concentrations cluster around the alpha particles. This explains what Reich thought was a violation of the standard law of basic physics, stating that a high potential will always move toward a lower one, instead of vice versa. The lower concentrations of orgone, in the case of the Oranur Experiment, always had a greater affinity for the higher concentrations of orgone energy.

When radium was placed in lead shielding and then put in the safe, the alpha particles were largely confined to the region inside the safe. However, the orgone energy was not restricted and reacted with the concentration of alpha particles inside the safe. This affinity of negative charges for the positive, caused a large accumulation of orgone in the vicinity. The orgone, which permeated the walls of the safe and the shielding, opened the door for some alpha particles to escape. In turn, some deadly orgone energy was produced outside the safe, but not in lethal concentrations. The abnormally high count outside the safe was the result of the break-up of quantities of orgone energy releasing great numbers of harder electrons which reacted with the counter. The interactions of the orgone energy, with the very high concentration of positive charges inside the safe, caused an inordinate degree of disintegration of soft electrons. The undisturbed orgone allowed the hard electrons released to escape to the outside. It is now apparent that the unshielded radium did not produce a high count, because alpha particle concentration was not allowed to build up.

The radium used in the Oranur Experiment was then placed in lead shielding and buried in a place miles from the site of the experiment. It was exhumed after five years and tested. Surprisingly, it was found that the radium had lost much more than was expected. This was in direct violation of the established "laws" of nuclear physics. The continuous presence of high concentrations of orgone energy had transformed the radium atoms in a manner which was described in the chapter on the transmutation of elements.

Another phenomenon associated with orgone which Reich believed was a violation of the second law of thermodynamics, is that the temperature above an orgone accumulator is always higher than its surroundings. A deeper analysis shows the law is not violated. Gravity

tends to repel negative charges. Since orgone energy consists of soft electrons, a higher concentration appears at the top of the accumulator. The Earth's gravity then forces some of the soft electrons to escape outside the accumulator, resulting in a high concentration in this area. The increased concentration at the top, coupled with the bombardment from particles coming in, results in interactions and disintegrations. A general rise in temperature in this region is inevitable. (Figure 25 shows how the orgone accumulator functions).

It is interesting at this point, to note Einstein's reaction to this phenomenon. Reich gained an audience with the "great" man and brought with him an accumulator. When it was shown that the region at the top of the accumulator was at a higher temperature than its surroundings, Einstein admitted that it could be a "bombshell to physics". At his request, Reich left the accumulator with him for a series of tests with the understanding that it would be returned. After a period of several weeks, Reich received word from Einstein that someone had "explained" the phenomenon. The details of this "explanation" however, were never forthcoming and neither was the accumulator, although Reich repeatedly sent requests for its return.

It has been found the bottom of an accumulator becomes warm when suspended over running water. As mentioned before, soft electrons have a tremendous affinity for water. The orgone energy near the surface of the water is quickly absorbed. This creates a void automatically filled by orgone directly above. A chain reaction results with a rapid flow from the bottom of the accumulator to the water. The bottom vicinity of the accumulator is a focal point for this flow, and heats up in a manner similar to that of a short in an electric circuit. If the water were not flowing, it would soon become saturated; and the action would stop before much heating could occur. The flowing water provides a continuous outlet for the flow of orgone energy.

A new and recent discovery can revolutionize the building of accumulators. This discovery was revealed earlier in chapter 14. It is the use of gold-plated iron for the metal layers in accumulators. The reason for its superiority over any other metallic layer was also revealed in chapter 14. As stated before, all an accumulator or pyramid does is slow up the flow of soft electrons bombarding the Earth continuously. (They travel at a respectable percentage of light velocity). This produces a backup of particles inside the accumulators and pyramids and, thus, an increase in concentration.

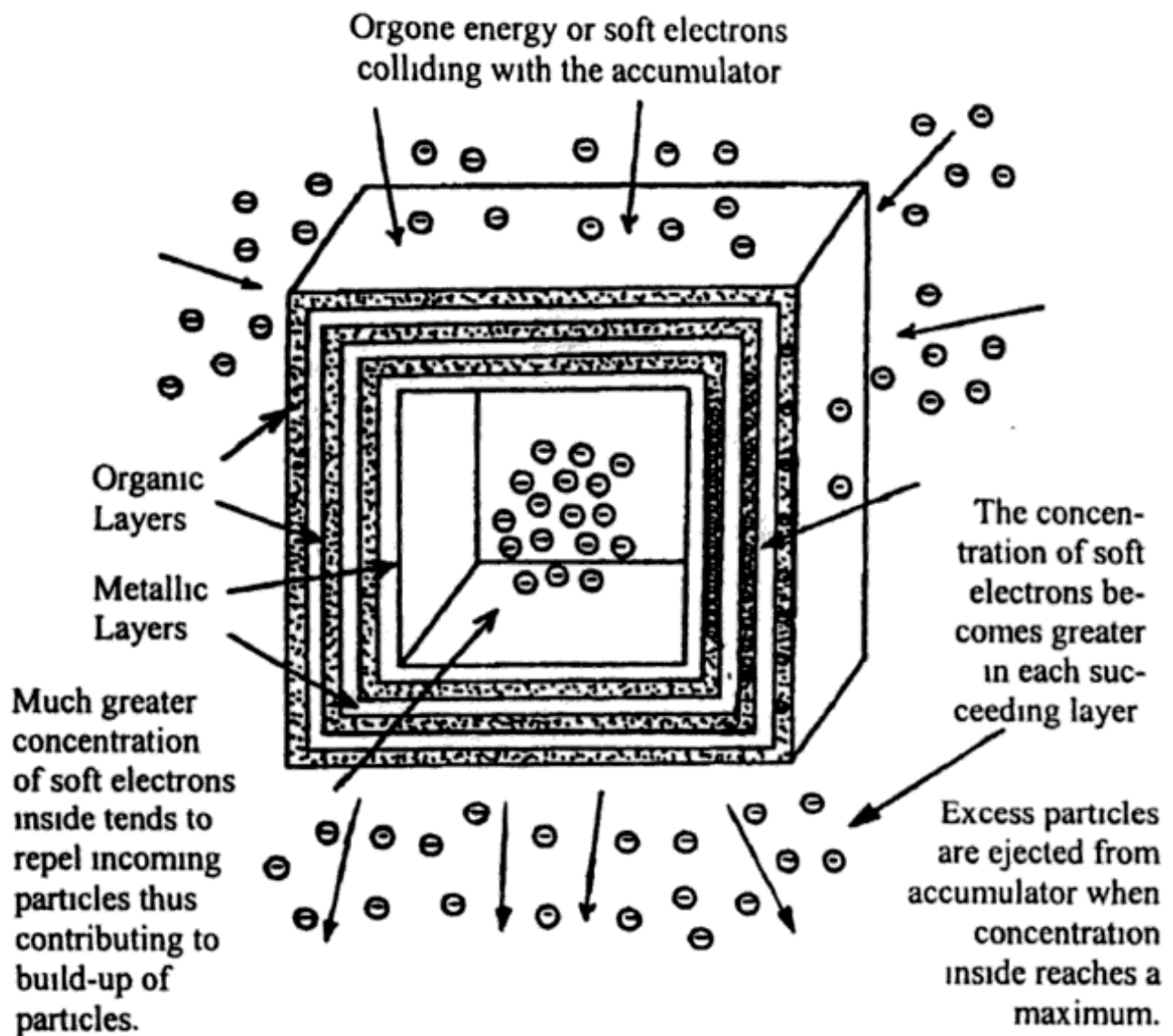

FIG. 25: REICH'S ORGONE ACCUMULATOR

Accumulators consist of alternate layers of organic and metallic materials. Basically, they tend to slow up the flow of soft electrons from outer space. This produces a backup and consequently increase in concentration inside. The organic material tends to absorb soft electrons since mutual repulsion between particles is reduced when they enter the material. Metal has a strong attraction for soft electrons. A thick layer forms on the surface, which repels incoming soft electrons, producing a backup and increase in concentration in the organic material. Particles which bleed through the metal have a lower average velocity than the incoming flow. Consequently, a higher percentage of them tend to be captured by the next organic and metallic layer. As a result, increasing concentrations of soft electrons build up around successive layers. There is an optimum number of layers that produce this effect because when the concentration reaches a critical level, repulsive forces become too great to permit a further backup of particles. Organic or metallic layers alone cannot produce this effect to any significant extent. In the case of organic materials particles leave the material with nearly the same velocity as before with no metallic layer to absorb and to slow them down. In case of metallic layer there is no organic layer to mitigate repelling forces which end to eject particles that get through the metal. Gold-plated iron makes by far the best metallic material for accumulators.

Metals or non-metals, by themselves, don't accomplish this to any significant degree in accumulators. In the case of metals, they soon become saturated with high concentrations throughout the metal and along the surfaces. Additional particles are ejected by mutual repulsion from the metal in the direction of flow at about the same velocity as that of the incoming flow. However, when the metal is in contact with a non-metallic, the repelling force tends to be dampened. Non-metals have positive field zones that are less intense while the negative zones are more so than in the case of metals. Also, non-metals more readily absorb soft electrons since the mutual repulsions of soft electrons are weaker inside the non-metallic substance. When the non-metallic becomes saturated, additional incoming particles are ejected in the direction of flow at a much lower velocity than that of the incoming flow. By itself, the non-metallic does little to slow the incoming particles. There are no concentrations of soft particles at the surface as in the case of metals. Even though there is an absorption of soft particles, repelling forces are too weak to appreciably slow up the incoming particles, and they readily pass through the material with small loss of velocity. What velocity is lost is regained by the relatively weak repelling force at the inside surface of the non-metallic.

From the above analysis it follows that for any given material, there is an optimum number of layers of metal and non-metal beyond which the addition of more layers does not significantly improve the performance. After the concentration reaches a critical value, repelling or ejecting forces become sufficiently great to prevent a further backup of incoming particles.

Expert dowsing indicates that the optimum number of layers of copper or aluminum foil and non-metals is about 20. Experiments seem to confirm it. According to a top dowser, gold-plated iron is over 100 times as effective as either copper, aluminum, or iron of the same thickness and even two layers of gold-plate iron and a non-metallic will be many, many times as effective as any number of layers of any other material. When only two layers of gold-plated iron is used, relatively thick layers of a non-metallic should be used. Up to a point, the thicker the materials used, the more effective the accumulator.

The question now arises. What is the best non-metallic to use? A membrane filled with water for the non-metallic layers would be more effective than anything else. This becomes apparent when the amazing properties of water are taken into consideration. Since an accumulator



is enclosed on all sides, it will, in general, concentrate soft electrons more effectively than a pyramid. The author has been informed that extensive experiments carried out in Italy has confirmed it. With the same materials and numbers of layers employed, a pyramid-shaped accumulator (completely enclosed) would, of course, be the most effective of all. It would incorporate the features of both the pyramid and an accumulator. It is more than likely that by charging the metallic layers of our accumulator in the manner of a condenser (alternately positive and negative) the performance can be significantly improved.

## **THE CLOUD-BUSTER**

The Orgone Principle just described is also the basis for an invention of Reich for controlling the weather, called a cloud-buster. Incidentally, the operation of the cloud-buster was known in ancient times and employed by Egyptians for weather control. This is, and has been, part of the teachings in mystery schools. The principle of its operation is depicted in Figure 26. It consists of a combination of parallel, hollow metal tubes. One end is grounded in water, preferably running water. The tubes are mounted so they can be pointed in any direction. When pointed at a cloud, the cloud-buster draws orgone energy out of it in the same manner like running water. The metal tubes have a positive charge which attracts the orgone and starts a flow of orgone along their surface toward the water.

It should be kept in mind that the orgone, or soft electrons, by themselves, do not have a strong attraction for metals because of the ethers with which they are associated. Some have not completely camouflaged the hard electrons they contain. Therefore, they will be quickly drawn to the metal. This creates the void that will be filled by other particles. The resulting excitation causes many to disintegrate and others to lose some of their ability to camouflage the hard electrons they contain.

Not all of the soft electrons comprising the orgone completely camouflage the hard electrons they have captured. Therefore, a significant number of orgone particles coming in contact with the metal are conducted in the manner of ordinary electricity. This produces voids along the conductor and a rush of orgone toward the metal tubes. There is more than enough water vapor in the atmosphere at any time or place to produce clouds. Water molecules have a strong

positive charge, and tend to collect negative charges or move toward high concentrations of them. Orgone is attracted to dust particles having positive charges, and water molecules, in turn, congregate around the combination of orgone and dust particles. If there is a high enough concentration of negative charges, water molecules will concentrate in sufficient numbers to form water droplets.

It is apparent that a cloud will quickly dissipate when the orgone energy is drawn out of it. The water molecules simply evaporate again, with nothing to hold them together. Thunder clouds contain a higher concentration of orgone energy than normal. The damaging and lethal effects of lightning are not due to the discharges of orgone energy itself as Reich thought, but to the hard electrons it releases when the orgone disintegrates. Lightning bolts consist of discharges of hard electrons, not soft ones. Reich was only partially correct when he concluded that lightning was a discharge of orgone energy. Thunder clouds are more likely to occur in the lower latitudes because these regions receive more orgone energy directly and indirectly from the Sun. They are more likely to build up over land masses than over large open bodies of water.

As it is the case with all natural phenomena, conventional science has never given a legitimate explanation for the behavior of lightning bolts. It has been determined that the flash moves from the ground to the cloud. During an electrical storm, an abnormal concentration of orgone is built up at ground level because of the tendency of negative charges to move to ground. This concentration is not uniform and at the point where the concentration is highest, soft particles will be repelled upward at great velocity. This creates a void in this area of ground level with the resultant rush of concentrated orgone in that region to fill the void. The tremendous agitation of soft electrons along the path causes the disintegration of soft electrons rushing toward the cloud.

Reich's cloud-buster can also enlarge clouds, and even create them when pointed toward an open area near a cloud. This again draws orgone energy away from that region, producing a strong positive charge. This, in turn, causes a rush of orgone from all directions to the affected area, and a chain reaction occurs. More electrons are attracted or set into motion than can be drawn off by the cloud-buster. The cloud-buster must then be pointed in a new direction, or the reverse process occurs.

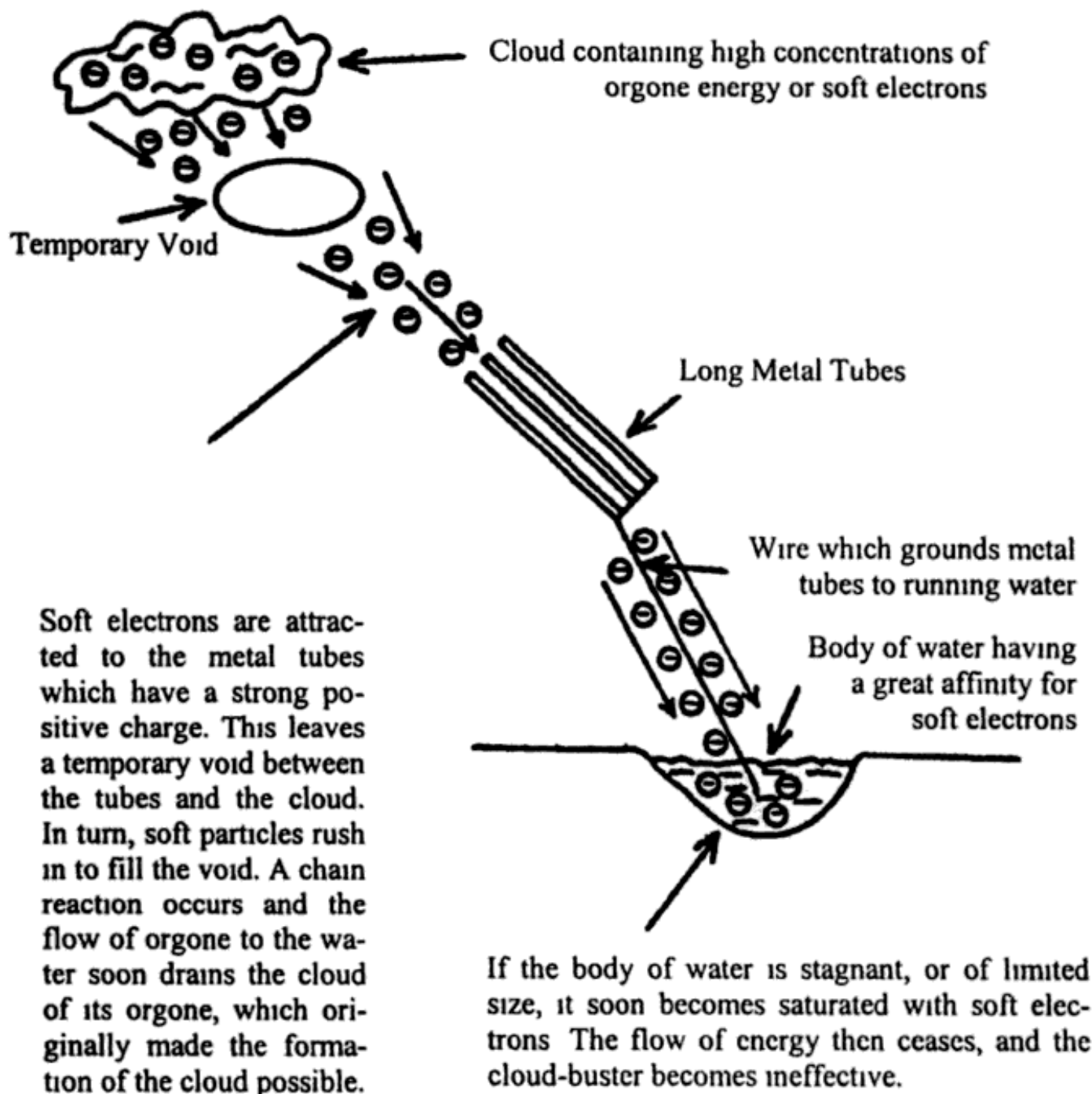

*FIG. 26: REICH'S CLOUD-BUSTER*

Reich's method of producing rain was far more effective than the popular one of seeding clouds with silver iodide crystals. Unwittingly, our present rainmakers are utilizing the same principle as Reich, but in a crude way. The tiny crystals have a positive charge. When they are dumped into a cloud a flow of orgone energy to the area follows, slightly increasing the concentration of orgone.

The principles described above also explain how UFOs interrupt the flow of electricity in power lines and auto ignition systems. UFOs probably employ sophisticated devices for drawing off and lessening the concentration of soft electrons around electric conductors. By drawing soft electrons away from the conductors, the source of hard electricity is cut off.

It should be mentioned that there is a minimum length for the tube employed in a cloud-buster if it is to be effective. There is a critical velocity or kinetic energy of the flowing orgone or soft electrons below which a general flow cannot be maintained because of frictional forces. The same principle is involved in the flow of electricity through conductors. Up to a point, the longer the tubes, the higher the velocity of flow which can be achieved.

Reich allegedly employed the cloud-buster to disable hostile UFOs in the area around his laboratory. The cloud-buster disrupted the electrical systems of these ships much in the same manner UFOs have stopped the flow of electricity in power lines. Reich and others have had experiences suggesting that many UFOs do not have the best interests of this planet in mind. The principle of the cloud-buster action underlines a wide range of phenomena to be discussed in later chapters. The ability of a cloud-buster to stop the flow of electricity in power lines is, of course, a dramatic proof of the validity of what has been discussed concerning the source of electricity. Other phenomena produced by the cloud-buster show the validity of other concepts presented in this treatise and will be revealed later.

The principle of the cloud-buster effect is demonstrated by a device which is known as "Transvector Air Flow Amplifiers" which utilize the Coanda Effect to produce large flows of air from a small primary flow of compressed air. The Coanda Effect is in principle essentially the same as that involved in the cloud-buster. The initial flow of air produces a low-pressure across openings by the Bernoulli Principle. This sets in motion relatively large volumes of air and a consequent flow up to 20 times as great as the primary flow. This 20 to 1 ratio is, of course, minuscule compared to orgone flow produced by the same principle, because of the near infinity greater activity of the particles involved. It is also another demonstration of the 2nd Hermetic Axiom. This same principle is deeply involved in a tremendous range of phenomena throughout the universe. For example, it plays a vital role in the formation of magnetic fields, in nuclear and atomic process, electrostatic forces, etc.

Another interesting phenomenon which is associated with the orgone energy Reich investigated, is the presence of tiny particles resembling spots of light darting about in the atmosphere. Anyone with normal eyesight can see them at almost any time. They are not figments of the imagination or optical illusions, since lenses will magnify them. Reich built an instrument called the orgonoscope for studying them. In fact, they consist of dust particles combined with orgone energy, and are not affected by gravity since the positive charge is neutralized by the negative charges.

The cause of other atmospheric phenomena may be apparent by now. A low barometric reading indicates an excess of negative charges in the atmosphere and an impending storm. An high barometric reading means a lower concentration of orgone in the atmosphere and a small likelihood of clouds forming. The concentration of negative charges is not uniform. This is a major factor in the changing weather. Ionized air molecules in the atmosphere will tend to rush toward concentrations of soft electrons. This sets up a chain reaction, affecting the atmosphere for great distances and generates winds.

Occasionally and under rare conditions, a combination of large quantities of orgone, or soft electrons, and positively ionized gas molecules is formed. The highly ionized gas molecules are almost completely camouflaged by the orgone. This is known as ball lightning. It is not affected to any extent by gravity, due to the balancing effect of positive and negative charges. The conclusion that it is largely a conglomerate of soft particles is demonstrated by its ability to pass readily through any metallic or non-metallic material and carry the gas molecules with it. It can be extremely dangerous, since it houses and camouflages large quantities of hard electrons along with the ionized molecules.

## **ADDENDUM TO CHAPTER 18**

Contrary to what the public has been led to believe, the big reason Reich was persecuted and murdered by the U.S. Government was his experiments with the cloud-buster. The potential of the cloud-buster is mind-boggling among other things, it can render modern warfare obsolete. Guns will not fire, bombs will not explode, engines will not function, any fire will be snuffed out, large armies can be destroyed,



etc. when a cloud-buster is trained on any of them. A small community with an arsenal of cloud-busters would be invulnerable to attack by the greatest war machines in the world. The Government was fully aware of this when it went after Reich.

Many have wondered how and why the author's two books, *The Awesome Force* and *The Awesome Life Force* ever saw the light of day in view of the fact all of this is exposed, especially in the latter book. As a matter of fact an all out effort was made by the power elite to suppress the first book. The CIA even planned to have this writer charged with treason if the book came out. When the time has come for a great idea to be unleashed on the world there are no powers on Earth great enough to stop it. It quickly becomes apparent these malefactors were not dealing with another Wilhelm Reich. The CIA soon regretted having even contemplated such a move. The fact both books came out and have had a wide reading speaks for itself.

There have been attempts to mitigate the damage done to the establishment by these books. One method has been publications in the guise of "revolutionary exposés" to draw attention away from the cloud-buster. The most recent is a book titled *The Montauk Project* by Preston B. Nichols. The book is about a secret government project he was a part of. It was linked with the famous Philadelphia Experiment which will be discussed in a later chapter. The experiments centered around the paranormal including mind control and so-called time anomalies. Many alleged mind-boggling phenomena were observed including so called time travel often employed in science fiction. Interestingly enough, there was a chapter devoted to Reich's experiments with orgone energy. As is to be expected the chapter was highly misleading and steeped in lies and misconceptions. It was stated he could take the violence out of storms with a "simple" electromagnetic device. No mention of the cloud-buster was ever made or the fact he could not only take the violence out of storms but could eliminate them entirely.

As has already been made more than evident the idea of time travel is nonsense of the worst kind. Yet, he claimed it was actually accomplished! His expounding on the nature of time is the most egregious this writer has yet encountered. The most efficient way to propagate lies is to mix truths with fallacies as has been done with this book.

## CHAPTER 19

# THE NATURE OF RADIOACTIVITY AND NUCLEAR DEVICES

## POPULAR MISCONCEPTIONS OF ATOMIC AND PARTICLE PHYSICS

To switch from the research of Wilhelm Reich to academic science in the realm of particle physics is like going from the sublime to the ridiculous. Ordinarily, no space would be devoted to such vacuous endeavors, if it were not for the vast sums of money and resources being poured into the construction and operation of worthless particle accelerators. One of these giant accelerators consumes as much electricity as an entire city. The purpose of this chapter is to expose the thought processes of physicists who have spawned the building of such monstrosities, and to evaluate what takes place in them.

The host of new particles observed by experimental physicists is produced by unnatural means, and has nothing to do with the operation of the atom. Their lifespan is so fleeting no rational person would call them particles. "Phantom particles" would be a more appropriate term. Perhaps the most remarkable of these phantoms is the neutrino. It is a true figment of the imagination, since it has never shown up in cloud chambers. Physicists continually invent these particles, which possess special properties, to enable them to surmount difficulties. Such is the case with the neutrino.

A few decades back, theorists were apparently confronted with a violation of the law of conservation of mass energy, as determined by the Theory of Relativity. This was really because of a faulty interpretation of certain nuclear experiments and the fallacy of the relation  $E = mc^2$ . The discrepancy was blamed on some hypothetical and illusive particle they called a neutrino. They had to assign it impossible properties to make it conform with their other misconceptions. They assumed it must have a rest mass of zero and a charge of zero!

The next step was to design some experiment to detect this wraith. Success was finally announced to the scientific world, after many years of frustration. However, an aspect of this great achievement was soft-pedaled. It was the reluctant admission the experiment only gave indirect, and hence inconclusive, evidence of the existence of the neutrino. Such a "minor" detail, and the consideration that any number of interpretations that could have been placed on the results, would not stand in the way of progress of modern physics for long. Their enthusiasm was not to be denied after such a long period of suspense and frustration. Consequently, these annoying facts were pushed out of the way, as many others have been. The neutrino is now given the same status of reality as the electron, proton, and even the atom itself. They can now discuss the neutrino with reckless abandon, without displaying any sign of remorse or guilt.

Physicists picked out the most illogical of all the various interpretations that could have explained the experiments, allegedly confirming the existence of the neutrino. Ironically, the neutrino was invented to salvage conservation, but it was assigned properties which violated the law! How could a particle with a rest mass of zero and a zero charge ever acquire any momentum or produce any energy effects without creating something out of nothing?

This is an example of the quality of thinking in which academic physicists indulge. Is there any reason to expect anything better in their present lines of research, which cost billions of dollars? The comedy centering around particle physics and its participants is too preposterous to have been conjured up by any dramatists prior to the advent of atomic physics. Instead of comedy, perhaps burlesque would be a more fitting description.

An alleged theorist will dream of some weird drama which should take place with certain particles. This, in turn, necessitates the involvement of a previously unknown particle with peculiar and unique properties. It is then decided what type of path it should produce in a cloud chamber. A long series of experiments follows with high-speed particles produced by accelerators. Thousands of photographs are examined to see if such paths can be found. Almost invariably, such diligent efforts are finally rewarded with success; and another grotesque theory has been "confirmed". What usually follows is great rejoicing and a celebration among the brotherhood. They have come a step closer to understanding the universe. There is an enigma usually connected with these events. It is indeed strange

that right after the discovery nearly everyone starts finding them, although, prior to this, multitudes had been engaged in the search for weeks or months without success.

Their greatest ally in such endeavors is the law of averages. One can usually find any kind of path one wishes to find when a sufficient number of interactions is recorded. The conclusion that the illusion of increase of mass with velocity is only a cluster held together by magnetic fields has been demonstrated in some of these experiments. High-speed protons meeting head on seem to produce a large number of new particles, which scatter in various directions. In reality, this is what happens when clusters of protons collide. The collision causes the clusters to break up into many of the protons, which were captured by the magnetic fields of the aggregate. The end of a path in a cloud chamber is frequently interpreted as the destruction of a particle. In many cases, it only indicates the particle lost its kinetic energy, or was captured by an atom or molecule or by soft electrons. The names assigned to the fantasy particles are congruent with the odd thinking of the physicists working on these projects. Examples of these are quarks and charms. The real tragedy is the wasted time, effort, material, and astronomical sums of money poured into these worthless projects, which only test out intellectual excursions into dream worlds, which are far removed from reality.

A typical article, supposedly justifying all of this nonsense, appeared in the February, 1978, issue of *Scientific American* entitled "Supergravity and the Unification of the Laws of Physics." This article brings one up to date on the work being done in theoretical physics and paints a rosy picture for the future. The following passage is taken from this article on page 131:

*The present understanding of the fundamental laws of nature arose from three principles: Special Relativity, General Relativity, and Quantum Mechanics. Each of them resolved an experimental or theoretical conflict, and each went on to predict new phenomena subsequently verified by experiment. Today there can be little doubt about their validity.*

## A NEW LOOK AT THE PHENOMENON OF RADIOACTIVITY

The conventional picture of the atom is that of electrons moving around a tightly packed nucleus of protons and neutrons in certain prescribed orbits. This nucleus is supposedly held together by some mysterious binding force. This is not the case. There are only two forces to consider: electrostatic and magnetic. This is in accordance with the 7th Hermetic Axiom. It is the neutralizing effects of electrons intermingling with protons, and the pinch effect of magnetic fields, which hold the atom together. The activity region of the protons is small compared to the electrons, since electrons are more active. The interaction of electrons with protons is the origin of neutrons, and in the larger atoms they constitute the majority of the particles in the nucleus.

Neutrons play an important role in keeping protons confined within certain boundaries, by moving between repelling protons. Zonal effects, as described previously, have actually been detected around neutrons, which of course was baffling to physicists. This is an excellent confirmation of the principles discussed earlier.

The chances for an electron to collide head-on with protons and neutrons in an atom will increase as the number of particles comprising the atom increases. If the electron and nucleus are moving in opposite directions, the collision can result in the disintegration of one or more of the particles, and the release of gamma rays. Sometimes, a combination of protons and neutrons can be ejected completely from the atom in the form of alpha particles, as well as neutrons.

The hard electrons associated with gamma rays have no preferred direction of spin, as is the case with softer electrons. Consequently, many of them can follow the right hand rule and be mistaken for positive charges and be called positrons. The alleged annihilation of a positron and an electron, when they collide with each other, is no doubt the collision of an unstable hard electron of a gamma ray following the right-hand rule. Such events have given rise to bizarre speculations about antimatter.

Antimatter has become such a widely discussed subject that even science fiction writers have gotten into the act. The theory of antimatter considers the possibility of matter existing in the universe



which consists of atoms with positive charges orbiting a negative nucleus. Such an arrangement is impossible. It is the nature of negative charges to be far more active than positive charges comprised of the same frequency photons. Therefore, a nucleus will always be positive, surrounded with negative charges.

It is the occasional collision of electrons with a particle, or particles, of the nucleus that produces the type of radiation which is known as radioactivity. For a given radioactive atom, the probability of such an event is infinitesimal. However, when great numbers of atoms are combined, the probability of this occurring in any given time interval increases in direct proportion to the number of atoms present. When the number becomes great enough, the concern is not about the probability of one such event, but how many during a certain time interval. The half life of a given radioactive substance is not difficult to understand.

After a definite period of time, one-half of the atoms will have experienced this event and have thus been transformed. This leaves one-half of the atoms, which means that such events take place with half the frequency. Therefore, in the same amount of time, one-half of the remaining atoms will have transformed, and so on. This idea of half-lives has been used to determine the age of various rocks and minerals, but it is extremely unreliable. The presence of high concentrations of soft electrons can greatly alter the half-life of radioactive materials, as demonstrated by the late Wilhelm Reich.

## **THE SOURCE OF THE ENERGY RELEASED IN NUCLEAR EXPLOSIONS**

Despite the fact that our illustrious physicists have managed to develop as highly a destructive device as a nuclear bomb, they still have no concept of the nature and source of the energy released after a detonation. As with all other well-known phenomena, they try to create the illusion that they comprehend and have explained. As a matter of fact, academic science has not yet supplied satisfactory explanations for any of the simplest and most common everyday phenomena. The energy released by nuclear devices is explained away by stating that it is a conversion of matter into energy in accordance with the false Einstein relation  $E = mc^2$ . Many readers,

especially those steeped in orthodoxy, may be shocked to learn there is no conversion of mass into energy during such a process, nor by any process in which energy is released! The tremendous heat produced in a nuclear blast means that an abnormal quantity of hard electrons were suddenly released by the complete disintegration of all the soft electrons within the area of the explosion. The intense light that accompanies the blast is the result of the photons set free by the disintegration of those soft electrons.

The key to the triggering of the reaction is the neutron. As indicated earlier, a neutron is equivalent to a collapsed hydrogen atom, and yet it is more than this. A hydrogen atom has a strong net positive charge, while the neutron has no net charge. This means that a neutron has collected far more hard electrons than a hydrogen atom. Since a neutron has no charge, it cannot add to the weight of an atom, as is commonly believed.

The concepts introduced in this treatise render all of the old beliefs concerning atomic structure invalid. The weight of an atom is dependent almost entirely on the number of orbital electrons and the number of protons in its nucleus. This will be discussed in more detail later. There is an exception or two to the above rule in the case of certain radioactive elements where the presence of neutrons can actually reduce the weight of an atom. An interchange of excess electrons between protons and neutrons within the nucleus, and thus transformations of protons into neutrons and vice versa, can occur. The neutrons greatly outnumber the protons in the heavier atoms, especially those that are radioactive. During the interchanges between neutrons and protons, excess neutrons disintegrate into protons and hard electrons are ejected from some of the atoms. This results in a transformation of such atoms. Simultaneously, the tremendous interactions between electrons released in this manner as well as from the disintegration of soft electrons in the vicinity cause the higher ethers to be disturbed, ultimately resulting in the production of gamma rays.

The isotope of the more common uranium 238 atom known as U235 is lighter yet it is fissionable and more radioactive than the uranium 238. It is lighter because it supposedly has fewer neutrons than the ordinary uranium atom. The opposite is actually the case. The U235 having more neutrons is more radioactive. The greater interactions within the nucleus result in more hard electrons being released, which reduces the overall positive charge of its nucleus.

There is a continuous interchange of ejected protons transforming back into neutrons and vice versa among the U235 atoms. A similar but less violent interchange takes place among the atoms of U238. A low percentage of the U238 atoms receive more than their share of these interchanges and thus transform into U235 atoms. Most of the hard electrons released which contribute to such interchanges and transformations is the result of the disintegration of soft electrons which permeate the atoms. It follows that the main contributing factor of radioactivity is the presence of soft electrons which house the hard electrons! Therefore, if the soft electron concentration throughout the vicinity of a radioactive substance is reduced, it will lose much of its radioactivity. By now it has no doubt occurred to the reader that a Reich cloud-buster pointed at a radioactive material would cause it to lose its radioactivity! This has been proven to be the case. For example, a glowing piece of radium stops radiating when it is placed in front of a cloud-buster.

The source of the energy released during a nuclear blast is now becoming clear. When a fissionable material like U235 or plutonium is bombarded with additional neutrons, the increased activity in the nuclei causes even the most stable soft electrons in the vicinity to disintegrate. A chain reaction of soft electron disintegration in areas well beyond the confines of the fissionable material results. All of the hard electrons and protons originally camouflaged by the soft particles are suddenly released. A tremendous gamma ray production also occurs. Adequate quantities of fissionable materials suddenly brought together can result in a sufficient increase of neutron bombardment of the interior atoms to produce such a result. It is known as the critical mass. The proper fusion of hydrogen atoms can also cause enough soft electron disintegration to produce a similar result. It is now apparent there is no conversion of mass into energy during the process. All of the fundamental particles of the atoms involved remain intact. In fact, there is even more mass following a blast than there was previously, as a result of the additional hard electrons and protons released. Once again it is obvious that the Theory of Relativity is in no way concerned.

The monstrous hoax fostered on the public by the defense department of the Government now becomes more than obvious. A Reich cloud-buster can completely deactivate nuclear devices for great distances by drawing away the soft electron concentration from the vicinity of such device. In fact, a cloud-buster can be used for

downing fleets of planes carrying nuclear weapons. Combustion is also dependent on soft electron concentrations which of course includes jet engines. Therefore jet engines or missiles cannot function in an area affected by a cloud-buster. For a mere several thousand dollar investment any country can be rendered invulnerable to any missile and nuclear weapon attack! The fact that a simple cloud-buster can deactivate a nuclear reactor from a great distance has been proven on numerous occasions. For example, during the time Reich was carrying out intensive experiments with a cloud-buster in Arizona in the early 1950s, a large reactor several hundred miles to the southeast quit functioning. This means that hundreds of billions of tax dollars are being funneled every year to support a multibillion dollar nuclear industry and other related industries which are rendered obsolete by the device used by Reich.

It is evident that the proper use of the cloud-buster could throw modern warfare back to the stone age. Combatants would be reduced to the use of clubs, rock throwing, bows and arrows and the catapult. Invasion fleets would consist of sailboats, canoes, rafts and balloons. The cloud-buster could even nullify this kind of hostilities. Obviously the drawing of soft particles away from any group would completely enervate each individual and even turn him into a block of frozen flesh. Although a cloud-buster could not completely deactivate a particle beam weapon it could bring down any craft carrying such a device before it could get into position. Since officialdom in Washington, D.C., including the defense department, is fully aware of the potential of the cloud-buster, one can only speculate as to what kind of moral degenerates have been dictating the policies of this country and the enormity of crimes they have inflicted upon humanity. A discussion on the nature of radioactive contamination and the remedy has been reserved for Chapter 34 for reasons that will become apparent later.

The potential of the cloud-buster is perhaps greater than even Reich himself realized. Since heat is transferred from one body to another by soft electrons which release harder electrons, the cloud-buster can be used as a highly efficient refrigeration system by drawing soft electrons away from a body. It has been made apparent that this simple device can render present fire fighting techniques obsolete. By use of the cloud-buster in the proper manner, the loss of life and property from fire and storms could become a thing of the

past. It also provides dramatic proof of the validity of many of the new concepts introduced in this treatise.

Radioactivity was the subject of a ridiculous, if not amusing, fiasco more than two decades ago when two physicists, Lee and Yang, received the Nobel Prize in 1957. The incident, which was given wide publicity, concerned an error in the parity principle. The parity principle has been defined as "a mathematical concept impossible to define in physical terms". How such a concept could have any bearing on physical reality is not made clear. Generally, anything relating to reality can be defined in terms of reality, which is in conformity with the Law of Cause and Effect.

Incredibly, an experiment was devised to test the validity of this great revelation. It was based on the idea that a radioactive substance should eject more particles in one preferred direction, than in any other. Radioactive cobalt was chosen. It was cooled down to near absolute zero and exposed to a powerful magnetic field produced by a solenoid, in order to align the nuclei. Another physicist, a Dr. Wu, had devoted six months of hard work setting up the experiment. Indeed, it was found that more particles were ejected out of one pole of the solenoid than the other. Which pole was it? Of course, it was the pole out of which the magnetic lines flowed. Naturally, the experiment merely demonstrated that particles tend to travel down magnetic lines of force. The excess of particles that came out of the pole were those barely ejected from the atom. They had such a low initial velocity that, regardless of what direction they happened to be traveling initially, the magnetic field would dictate their final direction of travel.

Lee and Yang were accorded every scientific honor, including the Nobel Prize, as a result of this experiment. Instead of giving them the Nobel Prize, the awarding of an Oscar would have been more appropriate. Accompanying the extensive publicity given this comedy act was a photo appearing in a prominent magazine showing one of the recipients pointing to a grotesque mathematical equation containing over 100 terms! He was allegedly explaining the reasoning behind their great revelation. Outside of the mathematical equation, the most amazing aspect of this performance was that he was able to keep a straight face throughout the demonstration. If the true significance of her experiment should ever dawn on Dr. Wu, a likely reaction could conceivably be (excuse the pun) "Wu is me!" This



event is another indication of how much so-called theoretical physicists lean on mathematics in their attempts to discover the secrets of the universe.

In view of the new concepts introduced in this treatise such as: the nature of gravity; that neutrons are virtually weightless and can even have a negative weight and therefore do not add to the atomic weight; that charge varies with velocity; there are thousands of electrons to every proton in an atom; etc., it becomes evident that the conventional picture of the atoms is completely false. Our venerated scientists have had no way of determining the number of neutrons and protons in any given atom. The number of orbital electrons in a given atom can vary considerably while the atom remains perfectly stable. The only differences will be in the physical properties of the materials comprised of these atoms. The chemical properties, however, will be unchanged. This presents an interesting paradox. The actual weights of the individual atoms will vary, but the determined atomic weights will be the same, which becomes evident from the fact that allotropic forms of a given element, including the isotopes, have the same chemical properties. It should be kept in mind that an allotropic form is produced by changing the number of orbital electrons. A question which arises at this point is: What is the difference between an isotope and an allotropic form of an element, since the conventional explanation is false?

The logical picture of the atom which emerges from these new concepts is as follows: The orbital electrons consist of concentric shells surrounding the nucleus. Each shell is comprised of electrons moving at the same velocity but in different orbital planes and in the same direction clockwise or counterclockwise, depending on the point of view. The electrons in each of these shells have the same general orbital direction. The velocity is such that the mutual electrostatic repulsion is offset by magnetic attraction. This is why all orbital motions must be in the same general direction. It also tends to prevent collisions between electrons. All orbital velocities must be well below light velocity, since it is electrostatic attraction which keeps the electrons in orbit. The outer electrons, of course, travel at lower velocities. They can be easily stripped off an atom because mutual electrostatic repulsion is greater. It is only the outside pinch effect of magnetic fields that tends to hold them in orbit.

An allotropic form of an element is one whose atoms contain more or fewer orbital electrons than the common form. The chemical

properties of an element is dependent almost entirely on the nucleus of the atoms comprising it. Consider what happens when an allotropic atom with more than the normal quantity of orbital electrons combines with another atom to form a molecule. During the process, soft electrons which are vital to all chemical processes absorb the excess outer orbital electrons which are more easily captured. The compound formed from the combination has all the physical properties of that produced by the combination with the common form of the element. There is, however, one subtle difference between the two compounds. The one produced with the allotropic form will contain soft electrons locked into it which are overloaded with the captured hard electrons and are thus relatively unstable. Most processes which reduce the compound to isolate the original element will also cause the captured orbital electrons to be released, and they will tend to resume their original orbits. The result is usually the original allotropic form. The author once witnessed a demonstration of this principle with an allotropic form of gold. Incidentally, there are many allotropic forms of elements which conventional science has never recognized or even suspected had an existence. This particular type of gold was in the form of a clay with about one sixth the specific gravity of saleable gold. The gold chloride produced from this clay had all the properties of normal gold chloride which formed an extremely heavy yellow precipitate. When heat was applied to the precipitate to reduce it, the result, instead of being gold as we know it, was the original clay!

Compounds produced from allotropic forms with fewer than the normal orbital electrons will have the same properties. In such cases, soft electrons involved in the process supply the additional electrons to make up the shortage. This form of the element has a higher net positive charge which draws more soft electrons to the area.

The question as to the difference between an isotope of an element and its allotropic form will now be presented. A true isotope of an element is radioactive, yet has the same chemical properties. A clue to understanding the difference between the radioactive form of an element and the normal form is that a certain percentage of the radioactive atom is always mixed in with the aggregate. Any given radioactive isotope atom has a limited life span before it transforms back into the usual form. This means that if normal atoms were not continually being transformed into the radioactive form within the aggregate, all the isotopes would eventually disappear and there would

be none left by now. Another clue is that the radioactive isotope radiates gamma rays continuously and is also heavier than the standard form. This has been attributed to the atom having additional neutrons. This is false. Another clue to understanding the difference is that when the orgone concentration in the vicinity of the isotope is removed by a cloud-buster, radioactivity ceases.

Since radioactive isotopes are produced within the aggregate, it follows that it cannot be due to protons being added to the nucleus. This conclusion is supported by the fact that the atom radiates gamma rays. This can only be done by the tremendous interaction of trapped electrons which are not in stable orbits. Since protons are relatively sluggish, their interactions would not produce a high enough frequency to create gamma rays. Since orgone concentrations are necessary for radioactivity to manifest, it follows that soft electrons are continually bringing in hard electrons past the orbiting electron shell and depositing them in the vicinity of the nucleus. Once a group of hard electrons are placed in the vicinity of the nucleus, their tremendous interaction tend to strip electrons off the protons in the nucleus. (It was shown earlier that it is next to impossible to strip all the electrons from a proton. Thus, what have been considered protons are actually highly ionized hydrogen atoms). The electrons stripped off the protons in the nucleus are quickly gobbled up by the soft electrons present. The highly agitated electrons are more difficult to capture. The electrons stripped from the protons in the nucleus give it an overall higher positive charge than it had before. This results in a heavier atom. When the orgone concentration is removed, the positive charge on the nucleus increases still more to the extent the agitated electrons are then captured by the electron starved protons, thus transforming the atom back to the standard form.

The picture is now complete. The more stable soft electrons are continuously depositing electrons in the nucleus of a certain percentage of the atoms in an aggregate. In any given such atom these electrons eventually escape and the atom transforms back to the normal state while others are being impregnated.

Chemists have mistakenly attributed the increased weight of a "heavy" isotope to additional neutrons in the nucleus instead of stripped protons. The picture is different when atoms that are naturally radioactive, such as radium, are concerned. Such atoms contain abnormal concentrations of neutrons, electrons, and protons in the nu-

cleus. Consequently, an aggregate of such atoms continuously radiates not only gamma rays but positive charges which are also inimical to living tissues. The role of soft electrons in this phenomenon has already been presented.

The structure of the nucleus has not as yet been properly analyzed. A group of protons by themselves would obviously fly apart in all directions. It follows that only the presence of particles with opposite charges could offset this. The neutron is the key. As mentioned earlier the neutron is equivalent to a collapsed hydrogen atom with far more than the usual number of orbital electrons. When a group of neutrons is clustered around each other the number of orbital electrons attached to any given neutron can fluctuate considerably. Outer electrons of a neutron can be stripped off by interactions with adjacent neutrons and then recapture electrons from another neutron with an excess of electrons. Soft electrons which permeate all matter can be disturbed sufficiently by these interplays to disintegrate and release additional electrons among the aggregate. Some electrons will escape the combination continuously but are replaced by disintegrating soft electrons, discharging new ones. The overall effect produced by this combination is a strong negative charge. Since the aggregate is relatively immobile, the protons will tend to orbit this combination. The mutual repulsion of the protons tends to be offset by magnetic attraction resulting from their motion. This in conjunction with the pinch effect produced by the surrounding ethers and the attraction of the protons to the negative charge holds the nucleus together.

Large fluctuations in the negative charge effects produced by the aggregate of neutrons result in corresponding changes in the velocity of the protons. This in turn affects the motion of the orbital electrons. The overall result is the creation of photons covering a complex range of frequencies. The greater the number of particles in the nucleus, the more complex the frequency pattern or the spectra.

## CHAPTER 20

### ATMOSPHERIC PHENOMENA

There are several factors which have not been considered in the academic explanations for winds and other atmospheric phenomena. It is significant that the Moon has a substantial atmosphere, and receives about the same intensity of radiation from the Sun as the Earth, yet relatively minor winds occur. Unlike the Earth, the Moon has a feeble magnetic field. This is one of the keys for interpreting atmospheric currents. Other factors include the hollow condition of a planet, the thickness of its shell in relation to its diameter, and the Coriolis effect. Winds, tornadoes, and cyclones can only be adequately explained by taking into consideration the nature of orgone energy, or soft electrons, and their interactions with air molecules. These explanations for atmospheric phenomena will be followed by suggested methods of weather control, based in part on the research of Reich and others.

Air currents seem to be generated from electrostatic forces caused by the presence of concentrations of hard and soft electrons in the atmosphere. The rush of these charges toward lower potential areas creates a charged particle stream. This stream generates wind, because the ionized air molecules tend to be drawn along with it. Since soft electrons are continually disintegrating and releasing camouflaged hard electrons contained inside, the electrostatic forces will primarily be the result of hard electrons.

It has been demonstrated that a bar magnet which is long in proportion to its width has a number of nodes distributed along its length. These nodes result from the magnetic lines which tend to follow oval or circular paths. The magnetic lines flow out of one pole and back into the side, instead of flowing into the opposite pole. This point of entry generates a node, which becomes the starting point for another flow out of the side and back into the magnet at a second node.

Geomagnetism was explained in a previous chapter as the result of charges in the atmosphere moving with the Earth in its rotation. In addition, the shell of the Earth should act then as a bar magnet. It was shown that particles bombarding the Earth tend to slow down as



## CHAPTER 20

### ATMOSPHERIC PHENOMENA

There are several factors which have not been considered in the academic explanations for winds and other atmospheric phenomena. It is significant that the Moon has a substantial atmosphere, and receives about the same intensity of radiation from the Sun as the Earth, yet relatively minor winds occur. Unlike the Earth, the Moon has a feeble magnetic field. This is one of the keys for interpreting atmospheric currents. Other factors include the hollow condition of a planet, the thickness of its shell in relation to its diameter, and the Coriolis effect. Winds, tornadoes, and cyclones can only be adequately explained by taking into consideration the nature of organic energy, or soft electrons, and their interactions with air molecules. These explanations for atmospheric phenomena will be followed by suggested methods of weather control, based in part on the research of Reich and others.

Air currents seem to be generated from electrostatic forces caused by the presence of concentrations of hard and soft electrons in the atmosphere. The rush of these charges toward lower potential areas creates a charged particle stream. This stream generates wind, because the ionized air molecules tend to be drawn along with it. Since soft electrons are continually disintegrating and releasing camouflaged hard electrons contained inside, the electrostatic forces will primarily be the result of hard electrons.

It has been demonstrated that a bar magnet which is long in proportion to its width has a number of nodes distributed along its length. These nodes result from the magnetic lines which tend to follow oval or circular paths. The magnetic lines flow out of one pole and back into the side, instead of flowing into the opposite pole. This point of entry generates a node, which becomes the starting point for another flow out of the side and back into the magnet at a second node.

Geomagnetism was explained in a previous chapter as the result of charges in the atmosphere moving with the Earth in its rotation. In addition, the shell of the Earth should act then as a bar magnet. It was shown that particles bombarding the Earth tend to slow down as

they penetrate the shell. A cross section of the Earth would look like two curved bar magnets 1,000 miles thick and 12,000 miles long (Fig. 27). This configuration should result in multiple nodes, since it fits the pattern of a long, narrow bar magnet. At each nodal point or line, there should be a magnetic flow into and out of the outer surface of the shell, which carries a high concentration of soft electrons. The Earth's gravity would then tend to repel the ejected negative soft electrons out beyond the confines of the magnetic flow, so that they would tend to move north and south of the nodal line by mutual repulsion.

Magnetometers may not show great deviations in the Earth's field in these regions, because they only measure the fields produced by hard electrons. The majority of the particles ejected at these nodes will probably be the more stable soft electrons, which do not readily disintegrate to release the hard electrons contained inside. Sufficient groundwork has now been laid to explain the prevailing atmospheric winds, which are broken into six discrete bands from the north to the south pole.

Since the Earth has polar egresses, there should be a rapid flow of electrons of all kinds from both poles, in addition to those particles ejected from the nodal areas. Although the magnetic flow is into the north polar magnetic region, particles ejected out of the northern egress tend to spread out and flow in a southerly direction. The Coriolis effect then comes into play as particles move toward the south. This causes an additional accelerating force on the particles relative to the Earth's surface because the rotational velocity of the Earth increases as one moves toward the equator. The flow of the particles will be in a southwesterly direction since the Earth's rotation is toward the east. This produces a tendency for the Earth to move away from the particles, thus giving them a motion relative to the surface and toward the west. The flow will tend to carry ionized air molecules with it, creating the belt of westerly winds in the higher northern latitudes.

The six prevailing wind belts suggest the existence of two magnetic nodal lines between the north and south magnetic poles. Ejected particles at the first nodal line below the north pole will tend to move both north and south from the belt, as explained previously. Those that flow north will tend to move in a northeasterly

Cancellation of air currents occur between magnetic nodal lines as a result of air masses moving in opposite directions and converging at such points.

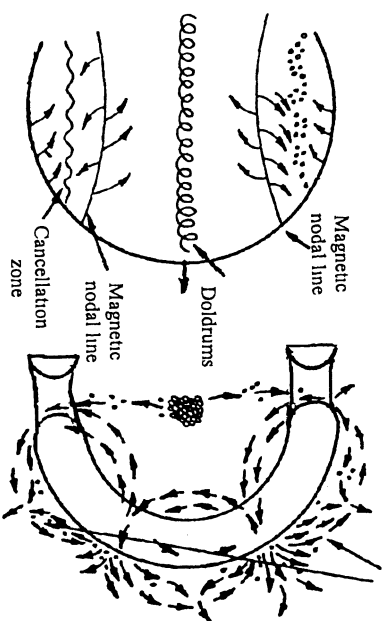

Coriolis Effect weakens rapidly as one moves from north or south to equator. Consequently, the accelerating force is not enough to compensate for frictional forces as equator is approached. As a result, prevailing winds become weaker in lower latitudes and vanish near equator.

Particles moving with magnetic flow coming out of Earth will have a higher velocity than those in the magnetic flow going into the Earth since they have added velocity due to gravitational repulsion. Consequently, they will tend to escape the Earth's magnetic field. Because of mutual repulsions some of them will be pushed south and some north.

direction because of the Coriolis effect. They will be given an acceleration relative to the Earth's surface in an easterly direction because they are going where the Earth's rotational velocity is lower. A cancellation effect is produced between the first nodal line and the north pole because the air masses moving in a northeasterly direction encounter the air masses moving in a southwest direction, nearly at the midpoint.

The particles that move south from the first nodal line produce the westerlies in the lower latitudes. The Coriolis effect weakens rapidly as one moves from the higher to the lower latitudes. As a result, the accelerating effect is less able to offset frictional forces as they approach the equator. Consequently, prevailing winds become weaker in the lower latitudes and vanish near the equator. This produces the doldrums or zones of calm along the equator. The same explanation that was mentioned above applies to prevailing winds in the southern hemisphere.

The pattern presented above will also be affected by land masses and the angle of inclination of the Earth in the plane of its orbit about the Sun. If the Earth were spinning in a plane perpendicular to the orbital plane and were completely covered with water, these wind belts might completely surround the Earth without any changes. However, the existing situation tends to disrupt this pattern and, as a result, produce a very complex weather picture.

The parallel belts on Jupiter may also be explained using these arguments. Recent space probes have indicated that the Jovian belts consist of high-velocity winds, which move in alternating directions similar to those on the Earth. Since Jupiter has a very strong magnetic field, its lines and belts are quite pronounced and relatively stable.

Since the Earth's shell seems to act like a bar magnet, due to the high concentration of rotating soft electrons in that shell, it is probable that the previously mentioned terraines running along the Earth's surface are the result of this magnetic field. In addition, pyramids of the past may have been constructed over areas ejecting large numbers of soft particles in order to take advantage of these natural concentrations and their various properties.

During an eclipse, there seems to be a significant flow of soft electrons from the lighted portion of the Earth to the shadow. It has been noted that animals are noticeably affected during a total eclipse in the same way they behave prior to an earthquake. This has been

FIG. 27. CROSS SECTION OF EARTH BETWEEN OPENINGS SHOWING CONFIGURATION OF EARTH'S MAGNETIC FIELD AND HOW SIX ZONES OF PREVAILING WINDS ARE PRODUCED

direction because of the Coriolis effect. They will be given an acceleration relative to the Earth's surface in an easterly direction because they are going where the Earth's rotational velocity is lower. A cancellation effect is produced between the first nodal line and the north pole because the air masses moving in a northeasterly direction encounter the air masses moving in a southwest direction, nearly at the midpoint.

The particles that move south from the first nodal line produce the westerlies in the lower latitudes. The Coriolis effect weakens rapidly as one moves from the higher to the lower latitudes. As a result, the accelerating effect is less able to offset frictional forces as they approach the equator. Consequently, prevailing winds become weaker in the lower latitudes and vanish near the equator. This produces the doldrums or zones of calm along the equator. The same explanation that was mentioned above applies to prevailing winds in the southern hemisphere.

The pattern presented above will also be affected by land masses and the angle of inclination of the Earth in the plane of its orbit about the Sun. If the Earth were spinning in a plane perpendicular to the orbital plane and were completely covered with water, these wind belts might completely surround the Earth without any changes. However, the existing situation tends to disrupt this pattern and, as a result, produce a very complex weather picture.

The parallel belts on Jupiter may also be explained using these arguments. Recent space probes have indicated that the Jovian belts consist of high-velocity winds, which move in alternating directions similar to those on the Earth. Since Jupiter has a very strong magnetic field, its lines and belts are quite pronounced and relatively stable.

Since the Earth's shell seems to act like a bar magnet, due to the high concentration of rotating soft electrons in that shell, it is probable that the previously mentioned terralines running along the Earth's surface are the result of this magnetic field. In addition, pyramids of the past may have been constructed over areas ejecting large numbers of soft particles in order to take advantage of these natural concentrations and their various properties

During an eclipse, there seems to be a significant flow of soft electrons from the lighted portion of the Earth to the shadow. It has been noted that animals are noticeably affected during a total eclipse in the same way they behave prior to an earthquake. This has been

attributed to a psychological effect produced by the darkness. The author personally experienced a definite physiological effect, which was exceedingly pronounced, during the February 26, 1979, eclipse. The effect was the same as produced by a magnet, an orgone accumulator, the Oregon vortex or a pyramid. The author does not believe he is particularly more sensitive than many other individuals, but was likely more observant and attentive to these effects. Due to the short duration of a total eclipse, and the excitement it causes, it appears most people might ignore the physiological effect the author experienced. What actually happens seems to be that the Moon momentarily blocks out the flow of soft electrons to the eclipsed area. This creates a void, which creates a subsequent flow of soft electrons to the area from all sides. This quickly results in a higher concentration of soft electrons in the eclipsed area than existed before the eclipse. Apparently, the duration of an eclipse is not long enough for large masses of air to be set into motion and generate winds.

A number of factors are required for a cyclone to develop. One of these factors is an abnormal concentration of soft electrons in an area. When this occurs, a rapid flow of soft electrons to the surface of the Earth takes place. This effect is enhanced over a large body of water, such as the ocean. A condition analogous to pulling the plug out of a drain is the result. Winds accompanying this effect produce a gigantic vortex. Once started, it increases and can continue to increase for a long period. The vortex creates a low potential in that area, and therefore causes a continuous flow of soft electrons to rush in from surrounding areas. It is extremely significant that most cyclones originate over oceans.

Tornadoes are more widespread and frequent than cyclones, and can be either clockwise or counterclockwise. The major cause, as with cyclones, is an extremely rapid discharge of soft electrons to the ground. A cloud with an abnormal accumulation of relatively stable soft electrons will seek out a channel of least resistance to ground. The flow of soft electrons through this channel produces a vortex consisting of a combination of highly ionized air molecules and soft electrons. This is accompanied by the rapid disintegration of soft electrons, which results in electrical discharges and lightning. A number of witnesses have seen the inside of a twister and attest to the continuous lightning discharges. Tornadoes occasionally lift off the ground when they encounter an area with a strong negative

charge. This repels the concentration of negative charges in the vortex. Once a tornado starts, the cloud that feeds it receives an increased flow of orgone energy from all directions, which perpetuates it. The tornado will burn itself out when it cannot draw in enough soft electrons to maintain the flow to ground.

Scientists are constantly seeking methods for stopping or preventing cyclones and tornadoes. Wilhelm Reich provided them with the fundamental means of weather control through his cloud-buster. Areas prone to cyclones could be monitored for abnormal concentrations of orgone, and these concentrations would be dissipated with giant cloud-busters on ships before they could attain destructive size. If a cyclone develops, these same cloud-busters could be placed around it and might be effective in eliminating it before it reached a land mass. On land, tornadoes could be stopped or prevented with cloud-busters, if a substantial quantity of running water were available to act as an orgone sink. If running water is not available, a device known as the Searl generator could be used to disrupt the abnormal concentration of soft electrons. The Searl generator can produce the low potential necessary to drain orgone from the cloud which feeds the tornado. The Searl generator will be discussed in detail in Chapter 22. Such devices could be set up in every area that is likely to experience a tornado. Such devices could be set up in every area that is likely to experience a tornado. Another fact that tends to confirm the principle outlined above is that tornados and cyclones do not occur in the higher latitudes. In view of what has been presented, this is to be expected. The atmosphere receives lower concentrations of soft electrons from the Sun.

This chapter has presented some of the basic rules governing atmospheric phenomena. At times, the weather pattern may be affected by nature spirits which are projections of the planetary Logos. These intelligences help to render a planet habitable and will be discussed in Part IV.



## CHAPTER 21

# PRACTICAL "FREE ENERGY" DEVICES WHICH COULD REVOLUTIONIZE OUR WAY OF LIVING

A free energy device can be defined as a machine that extracts or puts out more energy than it draws from its surroundings, or is put into it, to obtain this energy. The world of academic science has always considered this to be an impossibility since it supposedly violates the law of conservation of energy. Despite continual and undeniable proof to the contrary, the vast majority of orthodox scientists still refuse to recognize such realities. In view of the type of minds possessed by these men as has been revealed throughout this treatise, it would be completely out of character for them to behave in any other manner.

Many such discoveries have been made in this century. They have passed every test designed to prove them fraudulent. In each instance, the invention was suppressed and lost to the world by the underhanded tactics of such vested interests governed by unscrupulous malefactors whose only interests are the acquiring of money and power. Their success in preventing the widespread use of these devices was facilitated by afflictions which all but a few of the inventors seemed to have in common. These included acute cases of laryngitis and writer's cramp, at least where the details of their inventions were concerned.

In the pages to follow, some devices of this nature will be described and analyzed in detail. One in particular is a innovation of the author.

With the exception of magnetic motors, all of these various devices, are based on a principle and a fact that has been discussed repeatedly in this treatise. The principle is that all known space is permeated with soft electrons which, in turn, harbor enormous quantities of hard electrons. Essentially all such inventions consist of various methods of exiting these soft electrons to the extent they give up the hard electrons they contain. Less energy is required to disintegrate a soft electron than the energy released in the flow of hard electrons as a result of the disintegration. This is not a violation of the energy

conservation law since the total energy of the ethers involved remains constant.

## THE SELF-SUSTAINING ELECTRIC GENERATOR

With one possible exception to be discussed later, perhaps the most practical and useful free energy device is the self-sustaining electric generator. Many have been developed by different individuals at different times. The most famous and spectacular of these was demonstrated at Seattle, Washington in 1919 by an inventor named Hubbard. His invention was supposedly 14 inches long and 11 inches in diameter. It powered a 35 H.P. electric motor, which pushed a boat continuously around the bay for several hours. This demonstration was witnessed by thousands. A former associate of the author was one of those who claimed to have seen it. He stated that the most significant part of the spectacle was the tendency for the boat to levitate. The reason isn't difficult to discern. The generation of the electricity created such a high negative charge in the vicinity by the Coanda Effect that the boat was impregnated with an inordinate quantity of soft electrons. Hubbard soon afterwards abandoned his experiments and became silent with regard to his invention. It is not difficult to surmise what happened.

During the time of his demonstrations, Hubbard made a sketch of one of his smaller generators used for ordinary electrical appliances (see Fig. 28). It was approximately six inches long and about five inches in diameter. It consisted of eight coils in series, wound on iron cones which, in turn, surrounded a slightly larger central coil. The central coil was wound on a hollow tube which contained many small rods. They were, undoubtedly, comprised of soft iron. Four terminals extended from the unit. Two of them represented the outer coils which received the input current, while the other two came from the central coil.

It is highly significant that both wires used in the generator appeared to be of heavy gauge, like those used in telephone or power lines with the same kind of insulation. Each core had only one layer of this wire. This means that only a moderate number of turns were used in the entire generator.

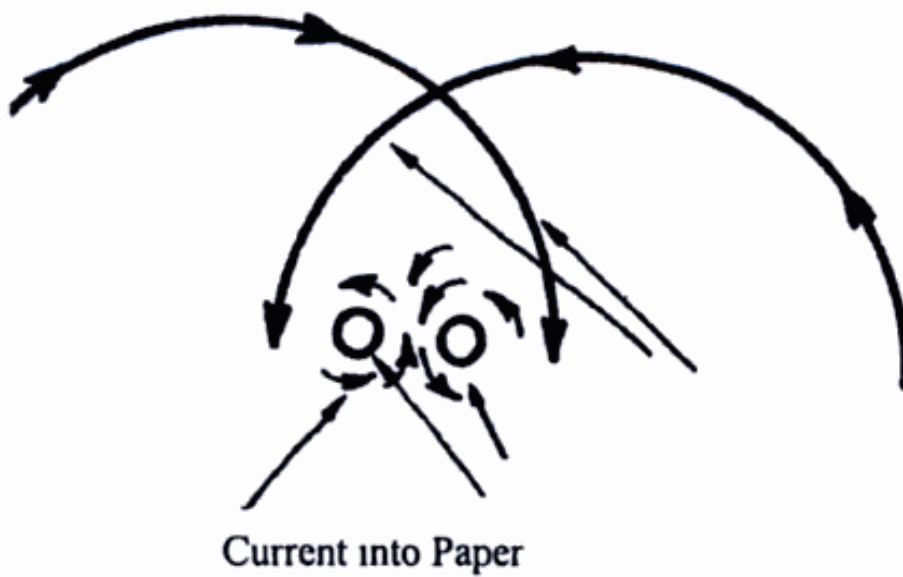

Magnetic field between wires tends to be canceled. As a result the total energy of field is greatly reduced and consequently inertial properties of flowing electrons

Only the weaker outer portion of the field envelopes both wires and tends to pull them together by the pinch effect.

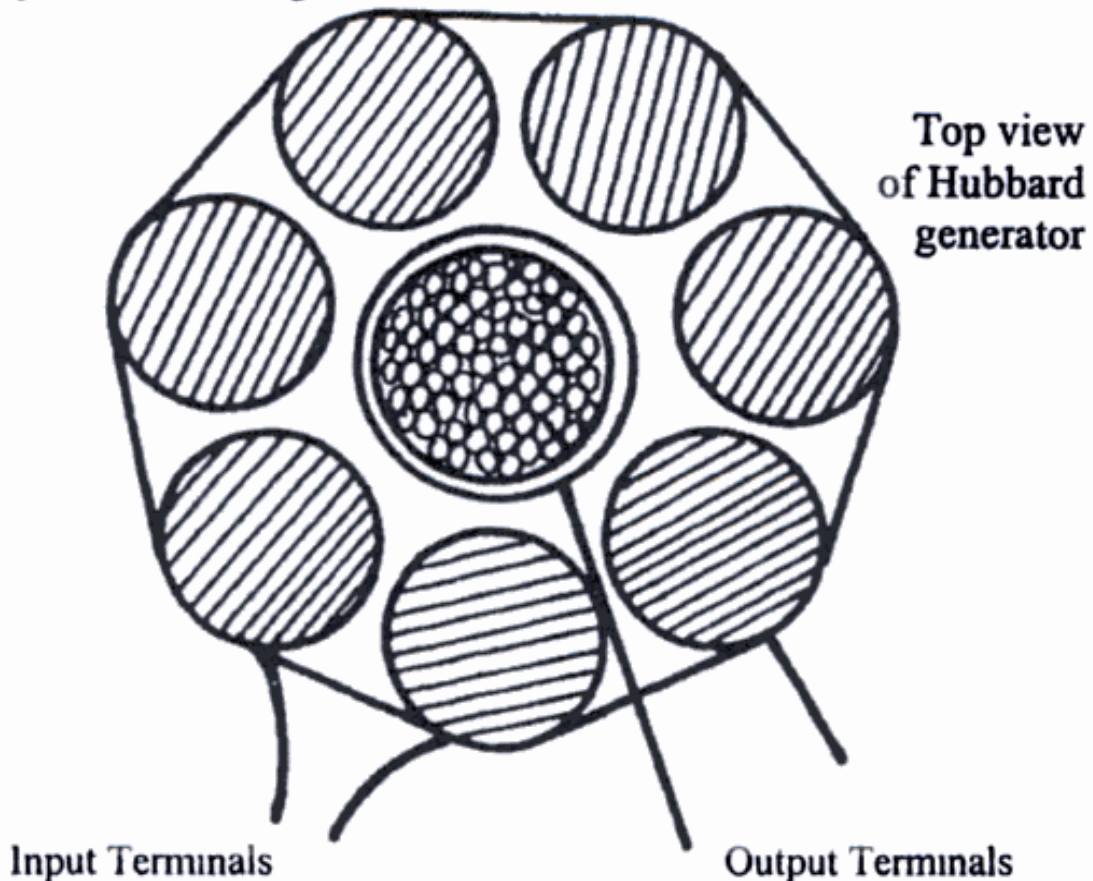

***FIG 28: DIAGRAM SHOWING HOW MAGNETIC AND CONSEQUENTLY INERTIAL EFFECTS OF FLOWING ELECTRONS ARE CANCELED IN ADJACENT SEPARATED SEGMENT OF COIL IN HUBBARD GENERATOR***

It is known that the generator produced a fluctuating current of an undisclosed frequency and had no moving parts. The basic principle on which the generator operated is apparent.

A small current passed through a coil with a moderate number of turns per unit length will magnetize an iron core to a surprising degree. This principle is utilized to a great advantage in electromagnets. What apparently hasn't been realized is that during the brief interval in which the current builds up after it is turned on, an induced EMF is produced in the coil by the changing magnetic flux, which is in the same direction as the current. This induced EMF is the result of the magnetic field produced by the magnetization of the iron core. If this induced EMF were in the opposite direction of the current, a sizeable current could never be produced in the coil. The EMF opposing the current would automatically cancel it before it could increase.

Figure 29 shows a graph of the magnetization of an iron core plotted against ampere turns per unit length. The term, "ampere turns" is the number of turns of the coil per unit length times the number of amperes of current flowing through the coil. For example, a current of one ampere flowing through a coil of 100 turns will produce the same effect as two amperes flowing through a coil of the same length which has only 50 turns. There is a section on the curve where a slight increase in ampere turns will produce a tremendous increase in the magnetization of the iron core.

The cause of this phenomenon should be analyzed. It seems paradoxical that a modest number of ampere turns can produce extensive and significant magnetization of the iron core. Yet, the observable magnetic field produced by the current without the magnetic core is minuscule in comparison. A similar field, produced by a permanent magnet, would be unable to induce a noticeable magnetization of the iron. This is something conventional science has found convenient to ignore. The solution to the dilemma becomes apparent in view of concepts already introduced. The normal flow of current in a wire is accompanied by an extensive flow of soft electrons in the same direction. This flow of soft electrons also permeates the iron core. As this flow of soft electrons passes through the iron, many of them tend to disintegrate, which tends to create a hard electron flow in the iron. This induces magnetism in the iron a considerable distance from the coil. The magnetic field produced by a permanent magnet does not produce a flow of soft electrons to the extent of that produced

by an electric current flowing in a conductor. When the ampere turns exceed a critical value, the soft electron flow in the iron reaches an intensity that results in a sudden and inordinate degree of disintegration of the soft electrons. The great increase in the hard electron flow in the iron creates a sudden increase in the magnetization of the iron.

If an alternating current is passed through an electromagnet and the ampere turns exceed this critical point, a chain reaction will take place in the coil which will result in a tremendous increase of current in the coil. This principle is responsible for transformers which occasionally burn out during current surges. The sudden increase in current is sufficient in some cases to put the ampere turn value over into this critical range. Strangely, such effects have baffled electrical engineers. The chain reaction results from an increase in the magnetization of

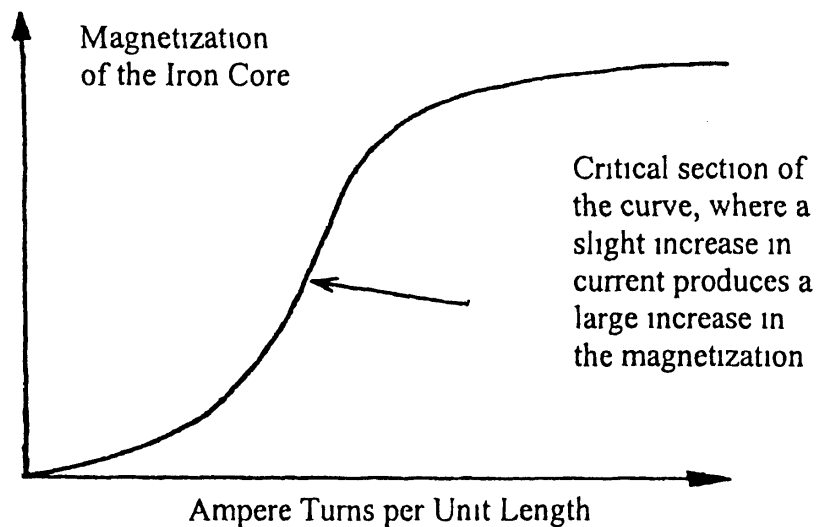

*FIG. 29: THE CURVE OF MAGNETIZATION OF AN IRON CORE VERSUS TURNS PER UNIT LENGTH*

the iron which produces an increase in the current, which in turn, produces an additional large increase in magnetization, and so on. This ends when the iron reaches its maximum degree of magnetization.

The above process occurs during the first half of the cycle. The EMF is flowing in the direction opposite to that of the current after it reaches its maximum value, and the second part of the cycle begins.



This EMF, which is of the same magnitude as that which brought the current to its maximum value during the first part of the cycle, now acts as a brake and stops the current. The applied alternating EMF then starts the current in the opposite direction, and the same identical process described above occurs with this current flowing in a new direction.

The normal operation of transformers involved ampere turns well below this critical point. The additional EMF induced in the coils by the magnetization of the iron offsets the natural inductive impedance of the coils. This is why transformers have such a high degree of efficiency. If any material other than iron or special steel were used for the core, the efficiency would drop significantly.

The author tested this principle of current or voltage increase during a cycle. A pulsed DC current from a battery source could be passed through an electromagnet. The voltage from the battery source should be considerably increased after passing through the coil. This is equivalent to stepping up the voltage of the battery when the portion of the circuit coming from the coil is used in conjunction with the opposite pole of the battery. The author tested this theory by placing about 2,000 turns on a steel bolt one-half inch in diameter and joining the ends of the wire to the opposite poles of a six-volt battery. A severe shock was felt when the circuit at the negative pole of the battery was opened and closed. It required about 70 volts for an individual, other than a sensitive, to get anything resembling a shock from an electric current under normal conditions. This means that, during the interval the circuit was opened or closed, the voltage increased from six volts to at least 70 volts and possibly well beyond 100 volts!

The author and an associate then tried the experiment with a pulsed current operated by an electric motor to pulse the current from a 12-volt battery. This produced several hundred pulses per second in the manner of the distributor on a car. The voltage increase from the single coil was sufficient to produce severe shocks if one touched the wire and pole of the battery. Paradoxically, the voltage and amperage increase would not register on a voltmeter or ammeter. The reason is clear. The current pulse was in the form of a square wave. The opening and closing of the circuit was instantaneous. The current during these infinitesimal intervals of time was increased tremendously in both voltage and amperage. However, the current produced consisted only of large bunches of electrons of high voltage, separated by relatively great time intervals with no current flow,

except for residual electrons which would register only a small current on the instruments. This means the total amount of current, during a significant interval of time, was small. Consequently, the instruments could not record these sudden increases. They didn't have sufficient time. However, the needles did vibrate, showing these sudden increases.

It is now clear that a normally pulsed DC current cannot be used in such a device. The experiments mentioned above only demonstrated the validity of the principle. This means that a pulsed current in the form of a sine wave must be employed. Since the induced EMF in a coil is directly proportional to the rate of change of magnetic flux, the higher the frequency of this pulsed current, the better. A sine wave pattern means that the changes will not be so abrupt, as was the case with the square wave. Therefore, the rate of change of flux to which the coil is subjected, will be much less for the same number of turns, than with a square wave.

There is possibly another factor which could contribute to the success of the Hubbard device of which even Hubbard, himself, could not have been aware. At that time, the only insulated wire available was that with the thick and heavy insulation similar to that used in power lines. This means that adjacent segments of the wire in the coils were separated by a distance equal to twice the thickness of the insulation. This, consequently, resulted in a cancellation of magnetic effects produced by electrons flowing in the wire. Since inertia is dependent on the ability to generate a magnetic field, the inertial properties of the electrons would be almost nullified. There is an optimum distance between the wires which would produce the maximum effect. Evidently, the insulation provided this optimum distance. Most of the resultant magnetic field was that which encircled both wires and would be the weaker part of the field. This means that a relatively low EMF could accelerate a larger number of electrons to a high velocity during a very short period of time. As the electrons leave the coil, inertia returns. This would result in a backup of a high concentration of electrons in the coil. Since electrostatic repulsion is not affected, electrons would be ejected from the coil at a high velocity despite their increased inertia. This would result in a high voltage and amperage output.

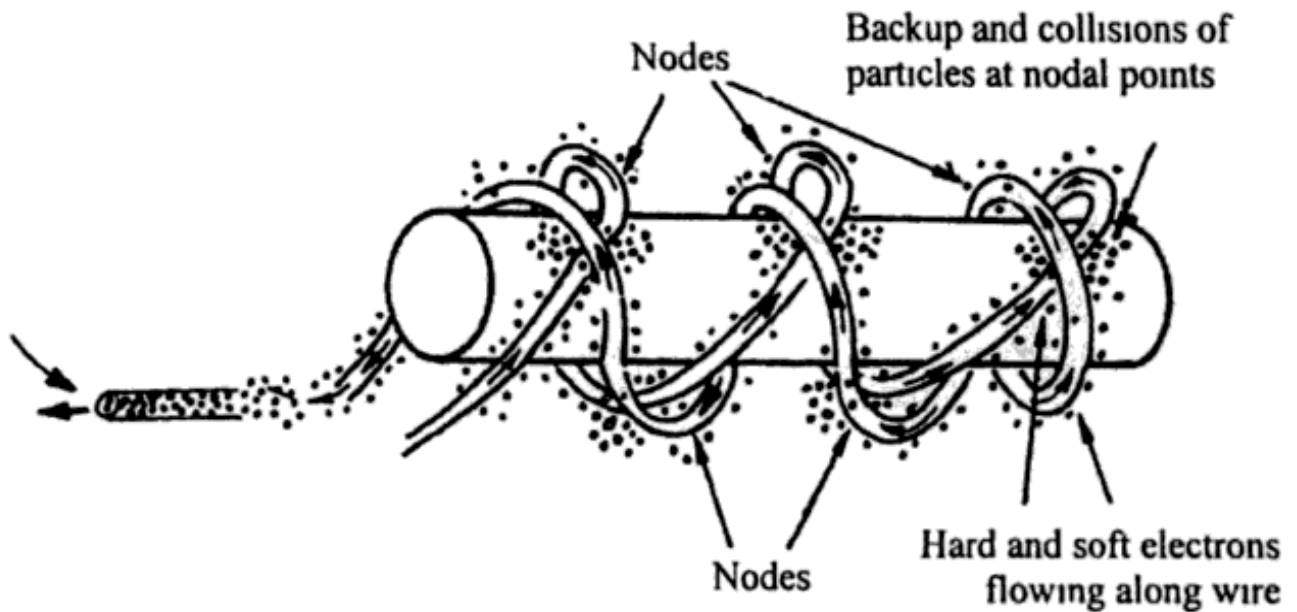

A laser-like pulsed beam of soft electrons is ejected from coil. The frequency pattern of the pulses is dependent on frequency of AC or DC, the input voltage and amperage and the characteristics of the coil. (The nodes should lie along a straight line for best operation)

Collisions of soft electrons also occur where segments of wire converge at nodes with the resultant release of large quantities of hard electrons.

FIG. 30: THE CADUCEUS COIL

*Due to cancellation of magnetic effects between nodal points both hard and soft electrons have lost much of their inertial properties. Therefore, a small EMF can produce a high velocity. They regain their inertia momentarily at the nodal points and lose their velocity. This produces a backup and collision of particles. Although inertial properties of particles are greatly reduced between nodes, electrostatic effects are unchanged. As a result the periodic backup of particles in the coil produces tremendous repulsive forces and great quantities of both hard and soft electrons are ejected from the coil at high velocities. A laser-like beam of soft particles is pulsed or radiated from the coil. It will have a longitudinal-wave pattern.*

As mentioned previously in this treatise, magnetization of an iron core is largely the result of magnetic fields produced by the flow of soft electrons which are far more extensive than that produced by hard electrons. The soft particles captured by such fields permeate the iron and disintegrate, releasing the hard electrons which magnetize the iron. Therefore, despite the extremely weak magnetic field produced by the near inertia-less hard electrons, the iron core will still be magnetized.

The above effect also accounts for the strange properties of caduceus coils which have long baffled researchers. The caduceus coil wound in the manner shown in the diagram in Fig. 30 shows no tendency to heat up with high amperages and has virtually no impedance. At high frequency AC, it has a tendency to levitate. As the reader will notice, adjacent segments of the wire are separated except at the nodal points where they cross along the length of the core on which they are wound. There is a tremendous concentration of hard and soft electrons at these nodal points where the inertia momentarily returns, causing a backup in the flow. A high frequency AC produces sufficient agitation of electrons, both hard and soft, to result in the release of hard electrons inside the core. This produces levitation. Since the hard electrons flowing in the wire have little or no inertia, they are unable to produce thermal agitation in the wire. Since impedance is due to inertia, it follows that impedance will all but vanish.

The reason for Hubbard using many iron rods in the central core rather than a single large iron bar should be made clear. A stronger magnetic field can be produced along the periphery of the hollow tube if it contained a myriad of individual soft iron rods, than would occur if the coil were wound on a solid iron core. It would have required a large number of ampere turns to completely magnetize a large core uniformly. However, in the case of individual rods, this is not necessary. The outer layers can be magnetized before the inner portions. Therefore, it is logical to assume that the hollow tube was also of soft iron.

During Hubbard's demonstrations, he claimed that his invention took the energy out of the air. Many years later, he contradicted himself and claimed that radium was the source of the current produced. This was an insult to the intelligence of the more discerning members of the population. He was an employee of the *Radium Company of America* at the time of his later disclosures. Evidently, his

later claims had a tendency to discourage experimentation with generators of the configuration shown in his sketch. He was no doubt coerced by vested interest into lying about his generator.

The most likely factor that contributed to the performance of the Hubbard generator is the possibility he used ultra-high frequency pulsed DC. Pulsed DC is vastly superior to AC in all respects. For one thing coils offer no more impedance or resistance to it than would a straight wire of the same ohmic resistance, yet it can be used in transformers more effectively than AC. The ignition coil is a good example. Since induced EMF is directly proportioned to the frequency for a given amperage it follows that an input current with a frequency in the 25,000 to 50,000 range would far more than offset a limited amperage input. A simple oscillator with no moving parts would accomplish this. A high induced EMF in the coils would automatically produce a comparable amperage as per Ohm's law.

Thomas Henry Moray, of Salt Lake City, developed a self-sustaining electrical generator which could produce a kilowatt of electricity for every pound of weight. This was about the same output as the Hubbard device. Apparently, he did not use the principle of changing magnetic flux to generate his current. Nearly one million dollars was spent in developing the device. A government agent accidentally, or perhaps on purpose, destroyed his device one day when he came into Moray's shop to examine it. Before Moray could stop him, he did things entirely contrary to the safety rules laid down by Moray for its safe operation. Lack of funds prevented him from ever rebuilding it. This was the story Moray told a former classmate of the author. As with all the others, it means that the complete secret of Moray's device died with him.

The Moray free energy device was quite complex and operated by ultra-high frequency charging and discharging of condensers in resonance with transformers. The key to the successful operation of the device was the use of special tubes he called ionic, cold cathode tubes. Interestingly, the wires carrying the high amperage never heated up. Undoubtedly, he applied the principle described above involving the Caduceus coil and the original version of the Hubbard device. Two or more wires running parallel to each other with the right separation and carrying currents moving in the same direction would offer no resistance to a heavy flow of inertia-less electrons. When they entered an electrical appliance the immediate backup of electrons in the wires would produce sufficient repulsive forces to force the electrons into



the circuit with adequate voltages. The major drawback to Moray's generator was its complexity and delicate balance which also made it susceptible to damage if improperly handled. Because of this, it was definitely inferior to Hubbard's generator.

Moray had a remarkable intellect. He developed sound detection devices and radio receivers which were vastly superior to any in operation today, and completely static free. All parts of his devices remained cool during their operation. He was also able to transmute elements. He had no peers in the field of metallurgy. He produced metals with abnormal melting points. One of his alloys had a melting point of 13,000 degrees Fahrenheit! Unfortunately, it seems that none of his discoveries is being utilized today.

Wilhelm Reich also developed a free energy device. He was supposedly able to draw enough electricity from concentrations of orgone energy to operate a 25-volt electric motor. In the book, *The Cosmic Pulse Of Life*, on page 325, Trevor James Constable specifies some of the parameters involved in this discovery. Even Reich kept the details of his methods to himself and one other assistant for reasons as yet undisclosed. The assistant disappeared, and sadly, as has always been the case, Reich's secret died with him. Reich utilized the concept that orgone energy houses vast quantities of hard electrons. A high concentration of orgone could be maintained in an accumulator. The orgone could then be made to disintegrate periodically in a manner similar to that of a lightning bolt. This was the source of the hard electrons. This ability of orgone to release hard electrons must have led Reich to the erroneous conclusions that orgone is the source of all matter.

Many years ago the author designed a greatly improved version of the Hubbard device. A prototype (according to information imparted to the author by an individual who knew one of the individuals involved in the experiment) produced sensational results. It was supposed to have put out so much current the output coil disintegrated. This particular design will not be given here because the application of a new principle can render all of the above mentioned devices obsolete. This particular type of generator was hinted at in Chapter 14.

The experiments of Schauburger and others have confirmed the enormous and almost unlimited quantities of electricity housed in water. The following is an absurdly simple and practical method of extracting this energy. It employs the Coanda or cloud-buster effect. A plastic tube about 14" to 16" long and about 2,5" in diameter is filled

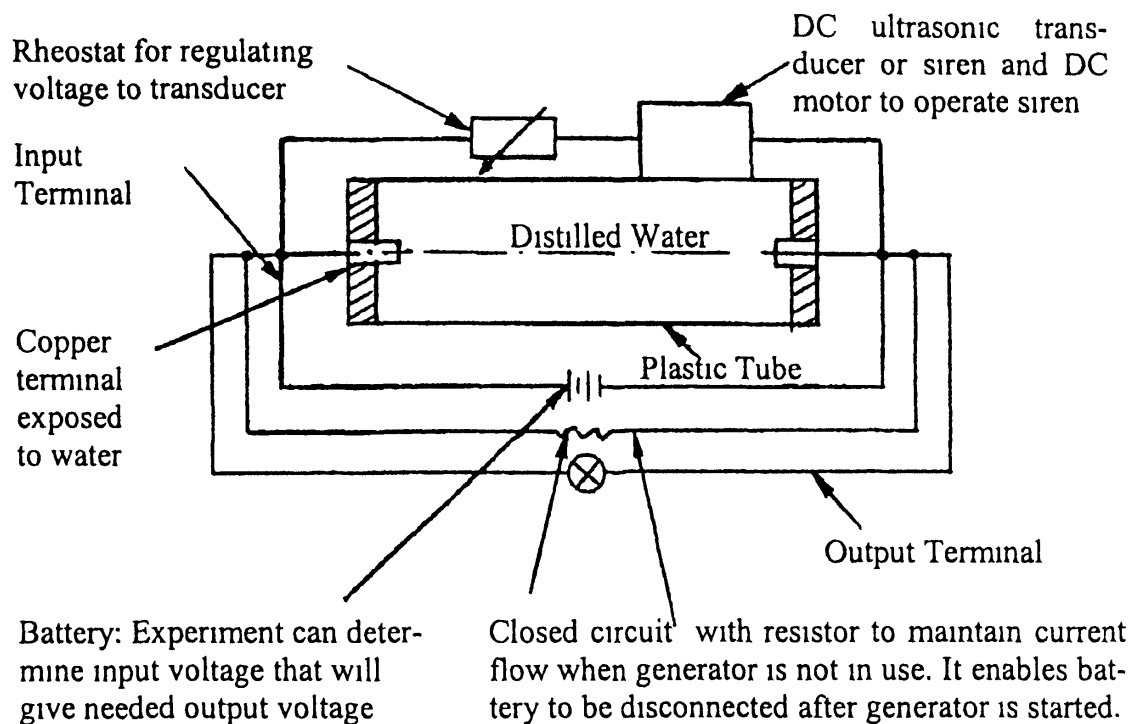

*FIG. 31: SELF-SUSTAINING ELECTRICAL GENERATOR EMPLOYING THE CLOUD-BUSTER EFFECT*

with distilled water. At each end exposed to the water are two copper terminals for both the output and input. Rechargeable dry cells of suitable voltage are hooked up in series to the input terminals. When the two output terminals are shorted or hooked up to a load electricity starts flowing. This is current entrained by the input current. When high voltage is applied the output voltage is almost as great as the input voltage. However, the amperage is inadequate. The answer to the dilemma is ultrasonics. It is an experimental fact ultrasound of 600,000 cycles and focused on a vial of water can cause it to boil. This means sound of this frequency disintegrates large quantities of soft electrons in the water. The sudden release of hard electrons produces tremendous thermal agitation of water molecules. A DC ultrasonic transducer attached to the tube would produce sufficient free electrons to be entrained for the unit to have almost unlimited output potential. The tube functions like a sounding board. The author has been given powerful evidence two different individuals who received the above information from him got sensational results with the generator. They

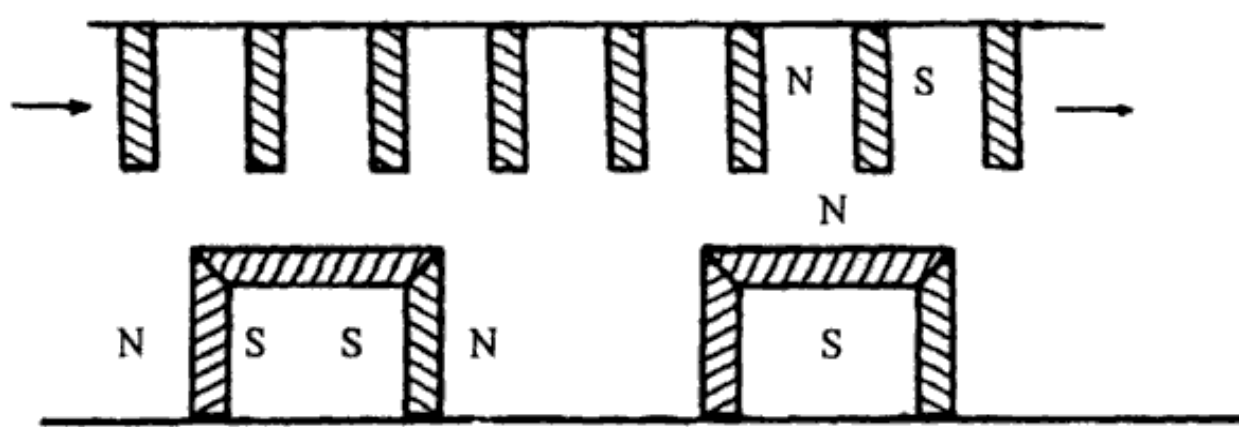

*FIG 32: ARRANGEMENT OF  
MAGNETS FOR A MAGNETIC MOTOR*

had access to such a transducer. Unfortunately, the power elite who have had this writer monitored 24 hours a day have so far managed to prevent him from acquiring one.

As for the two individuals mentioned above, greed and ego evidently took over. In any event the vested interests moved in and put them out of business. They have remained incommunicado ever since. An associate of the author built a siren about the size of a large fist that generated a frequency of 600 000 cycles! When focused on a small container of water, the water boiled! Obviously it could be used instead of a DC transducer on the water generator. A small DC motor could operate the siren. It would be far more effective than a transducer since the sound produced would have a higher intensity. There is also another advantage. With the siren the generator could be produced at a lower cost. Transducers are expensive. The diagram in Fig. 31 shows how the described generators can be built.

Motors powered by permanent magnets are another source of free energy. Several inventors have found a way of building such devices during this century.

The author has also designed a magnetic motor. Tests have proven that the principle involved is valid. It makes use of unipole magnets so that a net force is exerted at all times on armature magnets in one direction only. The unipole magnets consist of wafer magnets

magnetized through the thickness, and arranged and beveled in such a way that a unipole is the result.

The accompanying cross-section diagram in Fig. 32 shows the direction of the force exerted on the armature magnets by the unipole stator magnets which consist of wafer magnets magnetized through the thickness. In all positions the force exerted on the stator is in only one direction. However, it has been found that if stator and armature magnets are arranged in a complete circle, the force disappears. The reasons for this will not be given here. The optimum portion of a circle for which this force is effective is about 30 degrees. The difficulty can be surmounted by arranging a series of stators and armatures along a shaft which are each 30 degrees out of phase with each other. The armatures are all attached to a long shaft, which is free to rotate. Each combination of stator and rotor comprising 30 degrees of a circle is magnetically shielded from all the others. In each section the rotor magnets are far enough removed from the shields to prevent magnetic drag. This arrangement will produce a constant torque throughout the entire 360 degrees. There are any number of ways such a device can be controlled. Despite this, the author feels that DC electric motors used in conjunction with self-sustaining electric motors would be more practical than magnetic motors.

## **THE GREAT POTENTIAL OF CRYSTALS IN THE OBTAINING OF FREE ENERGY**

Crystals may have played an important role in the technology of ancient civilization which were far advanced over the present one. According to many testimonies, including that given by the late George Adamski, crystals are a vital part of the operation of UFOs. However, the reason crystals are employed in these advanced technologies have not been mentioned. The reasons will be outlined for the first time.

Crystals are basically a vast network of parallel plate condensers of unbelievable capacity. Incredible quantities of hard electrons, not a part of the fundamental particles of the atoms of the crystals are stored within them at all times. They are camouflaged by the soft electrons which permeate the crystals. Reichenbach supplied clues to the true

nature of crystals when he found they had a definite polarity. One end of a crystal exhibits a positive charge while the opposite end has a negative charge. A crystal consists of an orderly arrangement of atoms and molecules. The molecular arrangement of them is in the form of sheets or layers. It is the camouflaging or mitigating effects of the soft electrons which prevent the polarities from being more pronounced than they are.

The approximate energy capacity of a one cubic foot crystal will now be calculated on the basis that the dielectric constant between the layers is unity. The presence of soft electrons produces a dielectric effect of mammoth proportions. The distance between the layers is of the order of  $10^{-10}$  cm. This means that there are about  $2.25 \times 10^8$  square meters. The formula for the capacity, C, of a parallel plate condenser is  $C = Ake / d$ .

Where C is the capacity in farads, A is the area in square meters, K is the dielectric constant between the plate,  $e = 8.85 \times 10^{-12}$  coul<sup>2</sup>/Nm<sup>2</sup>, d is the distance between the plates,  $k = 1$ , and  $A = 2.25 \times 10^8$  m.

$$C = \frac{(2.25 \times 10^8)(8.85 \times 10^{-12})}{10^{-10}} = 4 \times 10^7 \text{ farad}$$

If the dielectric effects of the soft electrons are taken into consideration, it could conceivably be  $4 \times 10^{10}$  farads! A farad is defined as the capacitance of one coulomb of electricity contained in a capacitor with only one volt of potential between the plates. The voltage between successive layers of molecules is beyond normal comprehension. Two plates of one square cm separated by one centimeter with a charge of one ESU have a potential of one volt. This potential varies inversely as the distance between them. The amount of charge on a layer of molecules in a crystal and the potential between the layers is astronomical. The mind of the reader will not be boggled any further by bringing these considerations into the calculations. If only one volt exists between the layers of molecules in such a crystal described above, it would contain enough free electricity at any instant to supply a 100-amp current continuously for about 10 years!

It follows from the above consideration that crystals contain practically an unlimited quantity of electricity, which is not locked up



in the atoms. Civilizations of the past and builders of UFOs have found a practical way of drawing off some of the electricity from these crystals, whose store of electricity is replenished as quickly as it is tapped. It has also been shown that the physical universe is impregnated with a vast ocean of conglomerates of particles comprised of photons which cover the entire frequency range.

The fundamental reason for the electrical properties of the crystal will now be given. Consider two adjacent layers of molecules. The electrons in one layer tend to repel those in the adjacent layer. This produces a partial displacement of the electrons in these layers from their normal isolated positions. The protons are likewise displaced toward the electrons in the adjacent layers with no chance for any of the particles within the atoms to jump across. These great fields are mitigated by the soft particles permeating the crystal. An interesting effect results from this. The hard electrons contained within the soft particles tend to concentrate along the positive side of the layers. This produces a stress on one side of the soft particles with a tendency for the hard electrons to escape from them. This renders the soft electrons more susceptible to disintegration with the consequent release of hard electrons. This suggests a method for discharging large quantities of hard electrons from crystals.

If crystals were caused to resonate by sound of the right frequencies great numbers of the soft electrons within the crystal would disintegrate. This would release great quantities of hard electrons. The flow could be regulated by the intensity of the sound and also by periodically chopping off the sound. This is one possible source of power utilized by UFOs. The crystal could also be employed as a lethal weapon by altering the sound so that the crystal would project beams of particles of any desired intensity both hard and soft. The origin of the expression, "the terrible crystal" may have been from this application.

Perhaps the best way of tapping the energy concentrated within a crystal is by utilizing the principle described earlier, involving repeated reflections of a light beam from a combination of mirrors. A light ray, after many reflections, is converted into a beam consisting of a high concentration of soft electrons. If light traveling inside a transparent medium, such as glass or a crystal, hits the outer surface at the correct angle, it will be reflected back inside the material. This principle is employed in prism binoculars to make them more compact.

Assume the outer surface of a crystal is cut into a myriad of smooth facets at the proper angle to each other, so a light beam introduced at one of the facets will be reflected back and forth many times within the crystal before it escapes from a certain facet. If this beam experiences a sufficient number of reflections inside the crystal before it escapes, it will emerge as a potent laser. The concentration of soft electrons near the point of exit will be so intense that soft electrons housed by the crystal which are in the path of this ray will disintegrate, releasing a flow of hard electrons from the crystal. The disintegration of soft electrons and the subsequent flow will create a void which will tend to be filled in by surrounding concentrations. A constant flow of high voltage electricity accompanying the laser will be the result.

Crystals seem to have more of the characteristics of what is considered a life form than that of "inanimate" objects. Electron microscopes show a cellular-like structure. The size of the crystal also appears to be predetermined. A crystal grows by the orderly arrangements of atoms and molecules. There are three-dimensional constructions which cannot assume their final shape until the building process is complete. For example, one cannot start out with a replica of the complete structure in miniature and by building on this miniature replica, end up with an enlarged version of it. The size must be predetermined and the building process must proceed with this in mind.

The conclusion that the size of a crystal is predetermined seems to be inescapable. This means an external intelligence builds the crystal in a manner analogous to an embodiment. A parallel case is the creation of bions from inert matter, as mentioned in Chapter 18, which covered Wilhelm Reich's experiments. There is one essential difference between the embodiment of an intelligence with inorganic matter and that with organic matter. The opposite situation exists with organic life. This makes it possible to start out with a miniature replica of the final body and steadily increase its size while maintaining the original proportions.

Pure iron crystals are the strongest substance known to science. Whiskers of iron crystals have a tensile strength of over 500,000 pounds per square inch. Scientists have failed to explain why these crystals possess such strength. Once again, the explanation is practically self-evident. Since these crystals consist of pure iron, the individual iron atoms are in closer contact with each other. This results in a more complete, magnetic orientation of the atoms. The normal

cohesion added to the powerful magnetic attraction is a far greater factor than the cohesive forces alone. No comments were made public in regard to the magnetic properties of the crystals. Evidently, the whiskers were so fine that this aspect was not observed. Impurities normally found in iron prevent close mutual contact of the iron atoms, reducing the magnetic attraction of the atoms.

A demonstration witnessed by a personal friend and associate of the author clearly showed the validity of the concepts involving the property of crystals as outlined above. A quartz crystal the size of an average man's thumb was able to disperse clouds in the manner of the Reich cloud-buster. According to the man doing the demonstrating, the crystal was subjected to about 20,000 volts of electricity. A word of caution followed the experiment. A mirror must be placed in front of the "business end" of the crystal when it is not in use and during the charging process. What happened during the charging is apparent. The high voltage electrons ejected some of the outer electrons of the atoms comprising the crystal from the entire mass of the crystal. This they were able to do because of the partial separation of the outer electrons and the positive charge of the atoms resulting from the condenser structure of crystals. Consequently, the crystal was given a strong positive charge which was focused at one end of the crystal. Obviously, this would give it a powerful affinity for soft electrons. This, coupled with the crystal's almost unlimited capacity, provided a continuous sink for orgone energy. Large quantities of orgone absorbed by the crystal would do little to replace the hard electrons dislodged from the crystal and so the crystal would retain its charge for a long period. However, after large quantities of soft electrons are captured, disintegrations would increase by the charging process. The crystal, thus, loses its charge. According to this individual, a good crystal will hold its charge for about a month of use. The function of a mirror is obvious. It will reflect incoming soft electrons and prevent them from entering the crystal.

This friend of the author has heard of others who have utilized this process with crystals. One of them allegedly froze an entire swimming pool with a properly charged crystal! It was suggested that a crystal could be charged by bombarding the crystal with the current of the spark plugs of a car. This was later tried but with minimal results. The author exposed a quartz crystal for a long period to a 200,000 volt Van de Graff generator. The crystal was only charged to the extent of being able to slightly affect a thermometer and to produce a cooling

sensation when directed to the skin. It is more than apparent this demonstrator did not reveal all of his secrets. Few, indeed, are those that would under such circumstances. When the enormous capacity of a crystal is taken into consideration, it follows that not only are high voltages required but also high amperages are needed to charge a crystal to the extent of the one used in the demonstration. The amperage produced by an ignition system and a Van De Graff generator is extremely minuscule. The question remaining is "How was that crystal charged?" The only answer is that it was exposed to a power line which carries about 20,000 volts.

An enigma concerning power lines is that they are heavily insulated to the extent that the hard electrons they carry cannot penetrate the insulation. Yet, many have been electrocuted without even touching the wires. In fact, an individual, an associate knew, committed suicide by climbing a pole and throwing his hat at the lines. He was burned to a crisp. Such phenomena, of course, are beyond the ability of conventional science to explain, yet it is in perfect harmony with the concepts of soft particle physics. A power line produces a tremendous sink for the influx of soft electrons. If the voltage is high, a great turbulence of soft electrons is produced and, especially, if the current is AC. An extremely high concentration of highly agitated orgone is produced for significant distances from the wires, much of which is close to disintegration. Anything in this field with an affinity for soft electrons will result in a concentrated flow of orgone to the object with a discharge of hard electrons. Consequently, it is not the hard electrons carried by the wire that electrocutes, but the disintegration of soft electrons drawn to the wire. Charging a crystal by a power line can be extremely dangerous unless proper caution is taken. A crystal attached to a long, adequately insulated pole, could be one way of accomplishing it. Another way is the use of the self-sustaining electric generator described in this chapter. The output coil can be attached to a step-up transformer to bring the voltage up to 20,000 or more. At this voltage, the amperage would still be high enough to charge a crystal to the desired extent in a very short time.

Obviously, such crystals in the wrong hands could produce horrendous problems. However, the positive aspects would greatly overbalance the negative. Fire-fighting problems of all kinds would become a thing of the past, as well as tornadoes and other types of storms. Also, individuals in positions of authority, including police

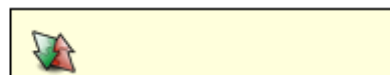

forces, lawmakers, judges, etc., would find it necessary to become more benevolent and responsible.

The frequent behavior of Diesel trucks when they run out of fuel during operation demonstrates principles already outlined in this treatise. Sometimes the engine runs wild and, at times, even disintegrates before the engine can be stopped. An investigation into this matter shows that this always occurs on hot, sunny days and never at night or on cloudy days. This is highly significant. The orgone concentration in the atmosphere is higher on clear, hot days than at any other time (except during auroral displays in the higher latitudes). From what has been introduced in this treatise, the explanation of the phenomenon becomes almost self-evident. The combination of the relatively high orgone concentration in the atmosphere, the ultra-high compression ratio of Diesel engines, and the heat already built up in the engine causes the more unstable soft electrons to disintegrate during the compression of the air. This doesn't occur when atomized fuel is present because much of the orgone is absorbed by the fuel. This produces a cushioning or dampening effect and prevents excessive agitation of orgone particles.

Recent verifications of the validity of the principle described above has been made in Australia, and by inventors in this country, with the development of fuelless air engines. An air engine consists of an air compressor that feeds air compressed to 2,000 P.S.I. to a piston chamber. At the top of the engine is a valve operated by a cam to inject a burst of compressed air to drive the piston. After the engine has run for awhile, a strange thing happens. The valve can be lifted and the engine will still run despite the fact that full pressure, 2,000 P.S.I. is being applied to the piston chamber at all times. As far as conventional science is concerned, it violates all rules of mechanics and the conservation of energy. From the standpoint of soft particle physics, the explanation is simple. During the initial stages of the operation of the engine, the more unstable soft electrons permeating the air are agitated to the extent they disintegrate. After the engine runs for awhile, sufficient heat builds up such that the more stable, soft electrons begin to disintegrate. Finally, when the valve is lifted, momentum will force the piston to the top of the cylinder, thus compressing a large volume of air already at 2,000 P.S.I. During this process, tremendous pressure, way beyond 2,000 P.S.I. results during compression. This, coupled with the heat already built up in the chamber, causes a high percentage of soft electrons to disintegrate by



the time the piston reaches the top of the chamber. The condition is identical to that in a Diesel engine which has run out of fuel during operation. It is to be expected that such engines develop far more power than that required to operate the compressor.

It is not surprising that the quietus was put on such experiments by vested interests. Threats and sabotage made it next to impossible to continue.

During the course of these experiments with air engines, an amazing thing occurred. The author will now quote from a letter received from one involved with the experiments:

*When this previous gentleman tested a Victor two stroke mower engine, he instructed a mate to turn the air on at the compressor room. He was holding the frame firmly to the floor when the motor increased to an extra-ordinary RPM A pink haze developed and all that could be seen was the piston. The rest of the engine was invisible! There were 3 or so other witnesses and they freaked out of their minds. It seems they won't talk about it now, probably due to the threats. The gentleman holding the motor tried to tell his mate to turn off the air, but he couldn't. He felt he was in some kind of a 4th dimension, a very strange happening. The fly wheel of the engines have magnets and I wonder if the rapid spinning magnets have anything to do with it? Any ideas you have would be appreciated!*

The phenomenon described above is deeply involved with the Searl effect to be analyzed in the next chapter along with the effects produced by spinning magnets. The Searl effect promises a highly effective means of producing unlimited quantities of electricity from a relatively small input of energy. The principles involved with the invisibility have been elaborated upon in a later chapter.

## **THE WORK OF TESLA WITH FREE ENERGY**

This chapter would scarcely be complete without some mention of the work of Nikola Tesla. Of all his many inventions and ideas, it seems only one of them was oriented toward what is termed "free energy". It is his much talked about wireless transmission of electrical energy. The idea incorporates the Earth as part of a resonating circuit. The Earth is treated as a terrestrial conductor which is allegedly thrown into resonance with electrical oscillations impressed upon it by

a resonant circuit which was grounded. Tesla assumed the Earth would behave like a perfectly smooth or polished conductor of inappreciable resistance with capacity and inductance uniformly distributed along the axis of wave propagation, and transmit low frequency electrical oscillations with scarcely any distortion or attenuation. Any given conductor would have a certain natural frequency to which it would respond and produce resonance.

A receiving device could allegedly be set up any place on Earth, and draw off any desired quantity of electrical energy (that is, within certain limits). The system would amount to so-called standing electrical waves of very low frequency being set up in the Earth. The degree of success Tesla had with this system in his experiments at Colorado Springs during 1899-1900 is questionable. His principle is not feasible in the light of concepts already introduced.

Tesla had no conception of soft particle physics which is vital to the understanding of any phenomenon. Also, since the Earth is largely comprised of non-conducting materials, it will not behave like a perfectly smooth conductor of inappreciable resistance.

Because of the range of ultra-soft electrons and photons concentrated in the ionosphere and the Earth, there should be more than one resonant frequency. Experiments with ELF radiations (extremely low frequency) have indicated the Earth resonates at 8, 14, and 20 cycles per second. Tesla predicted that these frequencies would be 6, 10, and 30 cycles per second.

The photons and soft electrons associated with ELF radiations are gigantic when compared to those associated with visible light. The ELF photons are of the order of  $5 \times 10^{13}$  times the diameter of the photons of visible light. Consequently, ELF photons and electrons house gigantic quantities of hard electrons. The disintegration of an ELF photon or electron starts a chain reaction. The harder particles they contain disintegrate with the release and progressive disintegration of still harder particles until the subsequent release of the hard electrons themselves. By repeated reflections, the ELF radiations which are unstable to begin with, become excited to the extent that they can easily be made to cough up the hard electrons they camouflage.

It was shown earlier during the discussion on the properties of light that it is difficult, if not impossible, to obtain 100-percent monochromatic light. Any light ray of a given alleged frequency consists of a conglomerate of photons of different frequencies. They

tend to be bound together by mutual magnetic attraction. The famous Land experiments demonstrated this fact. This same pattern applies to all electromagnetic frequencies down to, and including, ELF radiations. The frequencies assigned to any radiation generated by an oscillator are the average frequencies of the photons comprising the radiations. The majority cluster around this average. Some of them are of a higher frequency and some are of a lower. This makes the tuning of a radio receiver easier. If the incoming signal consisted entirely of monochromatic radiations or of only one kind of photons, extreme precision in tuning would be required. In fact, such precision might be beyond the capabilities of most radios.

Certain types of shielding can strip off some of the photons and soft electrons furthest removed from the average frequency of a radio signal of an ELF radiation. Physicists and technicians interpret this effect as stripping off the magnetic or electrostatic component of an electromagnetic wave. As stated earlier, the Maxwell Electromagnetic Theory erroneously states that a so-called electromagnetic wave consists of magnetic and electrostatic components, each at right angles to each other. This, of course, is contrary to the relationship between electrostatic and magnetic fields.

The main drawback to Tesla's idea even if it worked is that everyone would be dependent upon a central power source. In case something went wrong with it, everyone would be out of power. In any event, the populace would be at the mercy of a utility company as they are today. Ironically, Tesla is the father of the present system of electric transmission which is controlled by huge vested interests. As indicated earlier, these same interests have prevented the utilization of free energy devices. Had it not been for Tesla's contributions in this field, devices like that of Hubbard or Moray would likely have been in widespread use long before now. Consequently, the public would be independent of corporations for all their energy needs. The petroleum industry would not have the power and influence it has today, as well as many other corporations which are controlled by the same unconscionable people.

The Tesla patent on wireless transmission of electrical energy involves the use of pancake coils. A primary coil of a few turns surrounds the secondary pancake, one end of which is grounded and the other end attached to an antenna. An AC or pulsed DC put through the primary induces a tremendous flow of soft photons and electrons throughout the secondary, which are radiated outward by the antenna.

Tesla claimed a great amplification of current in the secondary by this process. From the standpoint of hard electricity, he was wrong. The production of hard electricity in the secondary was marginal. However, the production of soft particles by this process is startling. This is a highly effective method of disturbing the lower ethers in order to create soft photons by the implosion process. An associate of the author duplicated this experiment with the hope of producing a high output of hard electricity from the secondary pancake coil, since Tesla claimed it would. The results were impressive. The "electricity" produced could not be contained by the coil. It was highly penetrating and its effects were evident at considerable distances from the device. The electricity would not produce a significant shock, yet it would create the illusion of high voltage. The hard electricity induced in the secondary was minimal. The associate was both puzzled and disappointed with the result.

This strange phenomenon associated with pancake coils led Tesla to the erroneous conclusion he had discovered a new kind of wave, which he called a longitudinal wave, and to which the term "scalar wave", is attached. He attributed to it a weird set of properties including a velocity far beyond that of light. He was extremely vague about how he arrived at these conclusions, especially the velocity in which he used precise figures (292,890 miles/sec.). This is in keeping with other wild claims he made throughout his life concerning his discoveries, many of which were allegedly made when he had no means at his disposal to carry on experiments that required any sophistication. All he had was a hotel room.

Simple analysis involving soft particle physics shows that the end result was nothing more than an electromagnetic radiation with its greatest intensity in preferred directions traveling at light velocity. Visible light, of course, can be made to do the same thing. A wire carrying an alternating current will tend to radiate ELF frequencies (soft electrons and photons) outward from the wire uniformly in all directions. When the wire is wound in the form of a flat spiral with many turns, a number of things happen that don't occur with ordinary coils. The effects of centrifugal forces involving soft and hard electrons flowing in the wire and on its surface are compounded. Soft particles ejected from the inner portions of the coil interact and collide with those ejected from the outer portions. Those thrown off the inner part of the coil travel at higher velocities than those ejected from the outer layer because of greater centrifugal forces and soft electrons

from surrounding areas moving in to fill the void left by disintegrating particles, increases the interactions with the release of vast quantities of harder particles.

It also becomes clear that a higher percentage of the ELF radiations will be projected outward along the plane of the coil. Since they are basically produced in the same manner as other electromagnetic radiations, it follows they will have the same properties. It is illogical to assume otherwise. Since the concentrations of ultra-soft electrons would be extremely high along this plane due to the extraordinary quantities of electricity Tesla poured into his coil near Colorado Springs, it is not surprising that Tesla was able to tap considerable quantities of energy from these radiations at considerable distances from his coils. The soft electrons associated with ELF radiations would be very unstable, especially under such conditions. They could easily be made to give up the harder electrons they contained. There is nothing to justify Tesla's belief he had set up standing waves throughout the planet, and that these energies could be tapped to the same degree at any place on the Earth. The effect he observed were only localized.

His idea of the wireless transmission of electrical energy was a very poor one to begin with. Why go to all the trouble and expense to build a transmitter when unlimited quantities of such energies exist everywhere just waiting to be tapped by devices such as that of Hubbard, Moray and the author? It indicates that Tesla was either unaware of this fact, or was unable to conceive a practical self-sustaining electric generator. This alone puts the lie to a widely circulated story that he built such a generator in his hotel room when he was 77. He allegedly built it from electrical equipment that could be purchased in radio repair shops and the like. He supposedly used vacuum tubes in his device. It is claimed this generator was used to power an 80 horsepower AC (alternating current) electric motor, which was installed in a Pierce Arrow. According to the report Tesla drove this car at speeds up to 90 miles per hour. The AC motor was said to be 30" in diameter and 40" long (an AC motor would have to be of this size to put out 80 horsepower).

The entire story falls apart when rationality is applied. A motor of such dimensions could never fit in the engine compartment of any car of that time, and scarcely any car of the present day could hold it. It would also weigh about three tons and that much weight in the front end of a Pierce Arrow with no power steering would require a very



powerful man to operate, let alone a frail 77-year old man. Not even a man of Tesla's aberrations would use an AC motor. It would have been a DC (direct current) motor which is superior in all respects to an AC motor. It can operate at any R.P.M. (Revolutions Per Minute) and torque, and can generate far more power in proportion to size and weight. Interestingly enough, the description of the generator allegedly used fits perfectly the Moray generator. Most certainly if Tesla had built such a generator he never would have continued to advocate wireless transmission of electrical energy to the end of his life. The above is a perfect example of how Tesla's alleged achievements have been blown up way out of proportion to reality.

Since Tesla did not comprehend the principles of soft particle physics, he misinterpreted the results of many of his experiments. He was not producing voltages even approximating the magnitude he and others believed he was producing even though the soft particles created by his experiments gave the illusion of high voltage. Many of the soft particles would travel considerable distances before disintegrating and releasing harder particles. The misconceptions are identical in principle to the fallacies involving cosmic rays. The low frequency photons and soft electrons produced by Tesla experiments are relatively enormous and are capable of absorbing hard electrons.

Tesla was a good but not great electrical engineer and inventor. His ability was tremendously enhanced by a photographic memory and strong psychic and mediumistic abilities. By his own admission, etheric images, or thought forms of something he was trying to invent would appear in front of him, showing all the working parts. All he needed to do was reconstruct it, as it was shown to him. His invention of the AC electric motor came about in this manner. Exterior intelligences, no doubt, projected these images that could not be seen by anyone other than a psychic with clairvoyance.

Despite these special abilities, Tesla was neither a theorist nor a profound abstract thinker. He was at odds with Einstein in regard to the Relativity Theory, but for the wrong reasons. He didn't believe matter could be converted into energy or vice versa until the splitting of the Uranium 235 atom in 1939 with its consequent release of energy. He then changed his mind. It is ironic that Tesla was unwittingly correct in his original assertion concerning Relativity, but was unable to see that the experiment with U235 did not demonstrate the conversion of matter into energy. He was also taken in by the false and highly illogical theories and teachings of Walter Russell, as many

others were. He thought Russell's ideas were too advanced for the time, and the world would not be ready for them for at least 100 years. (The evaluation of Russell's scientific ideas will be given in Part IV). Tesla's lifestyle and the manner in which he handled personal problems were not what one would expect of a great intellect.

As with any well-established myth such as the Einstein myth, the Tesla Myth will not die easily. There are many Tesla zealots and worshippers who will not be convinced by what the author has presented thus far. Therefore, even more convincing proof that Tesla was far from being the savant he is universally claimed to be and in reality had a distorted view of the universe will be presented.

To Tesla's credit, he did not believe that light and all electromagnetic radiations consisted of transverse waves. His conclusion was based on the idea that the ethers are comprised of a gas and as such would not transmit transverse waves. He concluded that light was actually sound transmitted through the ethers as longitudinal waves. He was correct as far as the nature of the waves is concerned. From that point on, he had no conception of the nature of light. The following extract taken from the January 1919 issue of the *Electrical Experimenter* of an article written by Tesla demonstrates this fact:

*It is held that the Hertz waves emanating from a transmitter, get to the distant spot by successive reflections. The utter impossibility of this will be evident when it is shown by a simple calculation that the amount of energy received even, if it be collected in its totality, is infinitesimal and would not actuate the most sensitive instrument known, were it magnified many million times. The fact is these waves have no perceptible influence on a receiver if situated at a much smaller distance.*

Tesla believed that the signals picked up by the receiver is by a current passing through the Earth. This is explained by a further quote. *When a circuit connected to ground and to an elevated capacity oscillates, two effects separate and distinct are produced. Hertz waves are radiated in a direction at right angles to the axis of symmetry of the conductor and simultaneously, a current is passed through the Earth. The former propagates with the speed of light, the latter with a velocity proportionate to the cosecant of an angle, which from the origin to the opposite point of the globe varies from zero to 180° Expressed in other words at the start, the speed is infinite and di-*

*minishes first rapidly and then more slowly until a quadrant is traversed when the current proceeds at the speed of light. From that point again the velocity gradually increases, becoming infinite at the opposite point of the globe. ... In the near future many wonderful results will be obtained by taking advantage of this fact.*

If Tesla were correct then radio or Hertzian wave communications from outer space would be impossible, and radio and TV communication during the Apollo missions could never have happened. It has already been made clear that radio transmission is made possible by the soft electrons accompanying the transmitted waves, which tend to disintegrate when interacting with the receiver. This, of course, releases the hard electrons, which produce the signal. The above explanation is an example of absurdity in the extreme. This is another of many instances where Tesla has made ridiculous and wild claims he never substantiated. The absurdity of this idea has already been clearly shown.

He also concluded that the current from his transmitter passed over and through the Earth at a speed of 292,890 miles per second. He never revealed the "method" of determining this velocity, especially to such a degree of precision. It is incredible that no one even questioned any of his absurd claims, or how he ever arrived at his conclusion he had set up standing waves over the entire planet. The truth of the matter is Tesla merely deluded himself. The effect he produced were only localized and did not encompass the Earth as he believed. It has already been shown the giant pancake coils he built along with the tremendous quantities of electricity he put into them (which taxed the facilities of the entire city of Colorado Springs) produced ordinary electromagnetic radiations which had a tendency to radiate in preferred directions instead of equally in all directions. This does not make it a new kind of electric wave. Light, of course, can be made to do the same thing. The enormous quantities of electricity he used produced spectacular results. The pulsating field he produced with the pancake coils not only produced vast quantities of photons and soft electrons associated with the frequencies he used, but also agitated similar soft electrons in the surrounding ethers for considerable distances. It is not surprising that at times large quantities of relatively unstable soft electrons would disintegrate producing chain reactions causing the disintegration of other soft particles in the area with the release of vast quantities of hard electrons and visible light. This was

the spectacular lightening discharges Tesla described. It is to be expected that incandescent lamps could be made to light up a few miles from the transmitter. Powerful radio transmitters can do the same thing.

It now becomes clear that Tesla's system for the wireless transmission of energy is impractical. This is the reason J. P. Morgan withdrew his financial support for Tesla's experiments in this vein on Long Island. The popular belief among Tesla zealots has always been that the reason for this withdrawal was the disagreement between Tesla and Morgan, and to how the system would be used toward the betterment of mankind. This is complete nonsense. People generally believe what they want to believe. Morgan and the powerful interests he represented realized that by controlling energy they could control the people. Had Tesla's system been proven feasible they would have latched on to it and used it instead of the crude methods already in operation. Morgan and associates did not finance Tesla for altruistic reasons, but with the hope of employing Tesla's idea for a worldwide monopoly on energy.

The most fatuous reason advanced for Tesla's loss of support has been given by a leading propagator of Tesla's dogmas and fallacies, Thomas E. Bearden. (More about him later). The following is a quote from Bearden's *Solutions to Tesla's Secrets and The Soviet Tesla Weapons*:

*Thus by transmitting a scalar standing wave into the Earth, he could easily tap the energy scalar fields produced in the molten core of the planet itself, turning them into ordinary electromagnetic energy. In such cases, a single generator would enable anyone to put up a single antenna and extract all the free energy desired. When Tesla's alarmed financial backers discovered this was his real intent, they considered him a dangerous madman and found it necessary to ruthlessly stop him at all costs. The hope and belief that Tesla could accomplish something of this nature was why he was funded in the first place.*

For the rest of his life, Tesla lived in almost complete seclusion and poverty, surfacing each year at his annual birthday party for members of the press, to announce some recent marvelous discoveries and the perfection of his wireless transmission of energy. If members of the press and Tesla worshippers had been more gifted with ordinary common sense, they would have realized that Tesla was living in a dream world. He did not have the funds or the facilities necessary to make all of those wonderful discoveries he was describing to the press

each year at his birthday party. Tesla's extraordinary mental aberrations are well-known, but there has been a tendency to sweep them under the rug.

He always believed his "unique wave" could be used for interplanetary communication and also for interplanetary transmission of energy. Had his comprehension of the nature of the universe not been so minuscule, he would have realized there are unlimited quantities of energy everywhere ready to be tapped by a properly designed self-sustaining electric generator, as described in this treatise. This completely obviates the absurd wireless transmission of energy (even if it were possible) he harped on most of his life.

A quote from Ratzlaff's Reference Articles for Solutions to Tesla's secrets once again showed Tesla's ignorance of natural laws. *He held that all energy an atom exhibits is received from its environment and does not come from itself. Accordingly, he explained radioactivity as a result of the shattering of atoms by sub-atomic particles.* Tesla concluded that radioactivity is a result of cosmic ray bombardment. The results produced by the splitting of the U235 atom in 1939 put a crimp in Tesla's theory and forced him to do some reconsidering of past statements.

Undeniable proof that Tesla had a tendency to fabricate his achievements was his claim that he had produced electromagnetic waves of one millimeter wave length and had observed their actions at a distance. In fact, he stated he could send them around the world! Radiation of this wave length falls in the middle of the gravity-inducing range! Had Tesla been telling the truth, he would have found they could in no way be deflected, let alone be sent around the world. He would have discovered the secret of gravity and would have immediately announced to the world by far his greatest achievement.

Sufficient space has been devoted to exposing Tesla's shortcomings. Enough has been done to demonstrate beyond any question that Tesla was a long way from being the super-genius so many believe him to be. He was not a genius. He was not even bright enough to recognize the scientific gibberish (carried to dogmatic extremes) of Walter Russell for what it is, let alone the basic fallacies of Relativity. After reading the chapter on Walter Russell in the Part IV, it is left up to the reader to decide which of the three, Russell, Einstein, or Tesla is the most overrated figure in history. All three are worthy candidates. Of the three, Tesla was undoubtedly the most mentally unbalanced, as



well as being the most colorful. It is also more than evident there was a bit of the con-man mixed with these traits.

Since the author's stand on Tesla is a very unpopular one, it would be well at this point to review and clarify still further the case against Tesla. The tearing down of false gods and idols has never been an endearing process and it is not this writer's policy to compromise the truth in order to please the reader. It was stated earlier and clearly proven throughout this treatise that no adequate explanation of any phenomenon is possible without the concepts of soft particle physics. Therefore, anyone who tries any theorizing without it is going to fall flat on his or her face. This has been the case with Tesla since he had absolutely no understanding of the soft particle concept and the fact that soft particles house and camouflage vast quantities of hard electrons.

As stated in Tesla's writings, radio transmission is picked up by waves traveling through the Earth instead of by atmospheric reception. His argument was that the signals moving through the atmosphere were much too feeble to produce any energy effects on radio receivers, especially after traveling for great distances. If there were no such things as soft particles housing hard electrons, his argument would be valid. However, it has been clearly shown that radio reception is made possible by relatively unstable soft electrons and photons associated with radio frequencies disintegrating and releasing the hard electrons which are picked up by the antennas of the radios. Another simple fact that escaped Tesla and others and confuted his theory about radio waves passing through the Earth, is that radio transmission ceases when one is in a tunnel or a mine. Also, if his theories were valid, radio contact with the astronauts during the Apollo missions would have been an impossibility!

The colorful effects produced by his pancake coils and clearly explained in this treatise, led Tesla and others to the false conclusion he had discovered a new kind of wave with extraordinary properties. It supposedly suffered no attenuation effects in its passage through space and had a velocity much higher than that of light. Tesla, of course, never experimentally verified any of this nonsense and had no facilities to do so even if his contentions were valid. It was called a scalar wave. It has also been clearly shown this so-called scalar wave was nothing else but an ordinary Hertzian or electromagnetic wave. This becomes clear when it is realized that each and every segment of his pancake coil was independently radiating so-called Hertzian

waves. Thus, the combined effects couldn't have been anything else but plain electromagnetic radiations. Any other conclusion is nonsense. It follows he did not set up standing waves throughout the Earth as he had thought. They did not travel through the Earth, they traveled through the atmosphere and suffered the same attenuation effects as any other electromagnetic radiations. This would have been proven had Tesla set up his receptors a considerable distance, say a hundred miles, from his transmitter. It is more than likely this was done during his association with J. P. Morgan, it should be remembered that Morgan had a very sharp intellect with a scientific bent. At the university he attended, he showed an extraordinary aptitude for mathematics and debated whether to follow mathematics as a career or high finance before he chose the latter. It seems inconceivable that he would have dropped the project concerning the radio transmission of energy without having tested its feasibility after pouring a lot of money into it. After the radio tower on Long Island was built, which was the greatest expense, it would be highly illogical to drop the project before the pancake coils were installed and tested. This would be the easiest part of the project and the least expensive. Tesla's experience at Colorado Springs would have been a great asset during this part of the program. It also follows that a man of Morgan's intellect would have insisted on receptors placed at varying distances from the transmitter to test out the idea there were no attenuation effects. The results would certainly have proven there were. Morgan had an intellect that was uncommon among financiers and thus it is conceivable he did possess some degree of compassion, especially when it is realized he was interested in metaphysics and the occult. In any event, the situation involved in his dropping of the project was never revealed and only speculation surrounds his reason for cutting off his financial support. Perhaps he did not want to embarrass Tesla by publicly stating his reasons. It is also highly significant Tesla had no bitterness toward Morgan, which he more than likely would have had if the support had been withdrawn before any tests had been made.

Since that time and for the last 30 years of his life, Tesla lived in a dream world. He continued to harp on amazing new discoveries he was making. Discoveries the validity of which he had no way of verifying. Many of them are sheer nonsense in the light of this new science. A strong indication he was mentally unbalanced or at least a con-man or both is that he tried to give the media the impression he

had experimentally verified them! It is certainly incredible that scarcely anyone from that time up to the present ever questioned his outlandish claims or has taken an intelligent and objective look at the whole picture. Today everything Tesla ever said is taken as gospel and not to be questioned. Consequently, like any rumor, his alleged achievements have continued to grow until by now he is given credit for laying the foundation for just about every technological development of the present day. Yet, his best inventions suffer a bit when compared to those of such innovators as Moray, Abrams, Rife, Drown and a number of others.

In view of the above it becomes clear Tesla's contributions did even more to retard the advance of civilization than they did to advance it. The use of AC instead of pulsed DC has been a major liability. His AC motor is inferior in nearly all respects to the DC motor. It must operate at a constant RPM or it will burn up. The AC motor, of course, was developed to utilize the abominable AC. DC motors have now been developed that produce more power per unit weight than any internal combustion engine.

As mentioned earlier, one of the foremost promoters of the Tesla myth is Thomas E. Bearden, perhaps the premier scientific "double-talker" and "double-thinker" of the present time. No space would be devoted to him if it were not for the great following he is enjoying coupled with the horrendous scientific nonsense he is propagating. Bearden would have the world believe the Russians have utilized Tesla's secrets to develop fearsome weapons which threaten world peace. This is an example of Bearden's adeptness at "double-think." He stated that Tesla announced in the 1930s bizarre and terrible weapons, a death ray, a weapon to destroy hundreds or even thousands of aircraft at hundreds of miles range, and his ultimate weapon to end all war, the Tesla shield. Also, that Tesla died in 1943 without ever revealing the secret of these "great" weapons and inventions. If these secrets were never revealed, then the Russians could never have had any access to them. As a matter-of-fact, all these "great inventions" were merely a figment of Tesla's imagination, which he enjoyed entertaining the press with during his annual birthday parties. His basic understanding of nature's laws has been proven to be a big fat zero. This has also proven to be the case with Bearden, as can be readily shown from his writings. The following are quotes from his *Solutions to Tesla's Secrets and the Soviet Tesla Weapons*. It should

be noted that he referred to this "new wave" Tesla allegedly discovered as a "scalar wave".

*In my pursuit of Tesla's secrets, it gradually became apparent to me that present electromagnetic theory is seriously flawed in some fundamental respects. One of these is in the definition and use of  $\phi$ , the scalar electrostatic potential. It is this error which has hidden the long sought unified field theory from the theorists. (Bearden claimed to have uncovered 22 errors in present electromagnetic theory when in reality he never put his finger on one of them). The scalar electrostatic potential is therefore the instantaneous stress on space-time itself and a measure of the intensity of the virtual state flux through a 4-dimensional space-time point. .. This assumes a constant immutable rate of flow of time, which need not be true at all if we believe Relativity. Such a spatial point intensity is actually a line in 4-space, and not a 4-dimensional point at all and electromagnetic theory today is accordingly a special case of the real 4-space electromagnetism that actually exists! Note also that charge is a 4-dimensional concept.*

*Now mass is a spatial 3-dimensional concept. Primarily mass does not exist in time .. mass-time exists in time. Mass and charge are thus of differing dimensions! The scalar wave also violates one of Einstein's fundamental postulates for the speed of our "new kind of light" waves is not limited and need not be the same to every observer. Thus, Tesla's scalar waves lead to a new "super-relativity" of which the present Einstein Relativity is only a highly special case!*

The above quotes show conclusively Bearden is one of the greatest masters of scientific "double-talk" and at the same time his comprehension of reality is distorted beyond recognition. His writings show he believes in the absurd concept that the Earth is a solid ball with a molten core and that Einstein was correct as far as he went. These facts alone are sufficient reasons to dismiss all of his ridiculous and incomprehensible theories if one cares to dignify them to the extent of calling them such. This is only part of it. He shows he hasn't the foggiest notion of the true nature of time as clearly shown in this treatise. Also, he has failed miserably to properly define any of his grandiose and meaningless terminologies. Instead of clarifying anything, all he has done is convert an already extremely vague pseudo-science into something incomparably worse. He indulges in a lot of weird, zany, and highly impossible speculations as to the type of secret weapons Russia has developed from Tesla's secrets. He cites a

number of strange phenomena seen around the world in recent years as evidence Russia has such weapons, such as strange glows over mountain ranges, fireballs, etc. There could be any number of explanations for such phenomena. During his nebulous and inexplicable explanations of how such weapons could be built, he is at his best as a scientific "double-talker."

There is about the same likelihood of the phenomena described as being produced by Russian technology as was that horrendous blast over Siberia in 1906 that leveled trees for a radius of over 30 miles, and also the recent strange behavior of the planet Venus.

In view of the realistic analysis of Bearden's contributions to the mish-mash of scientific misconceptions, which comprise the attempts of present-day would-be theorists to comprehend the universe, the following excerpts to the foreword of Bearden's book, become even more extraordinary: *The long-searched for Tesla secrets have been solved by Tom Bearden. ... The explanations represented by the author provide clarity and understanding to Tesla writings and patents. .... Bearden's solutions are truly a major breakthrough, and an absolute necessity to the understanding of existing Tesla writings. It is also important that more should be known of this extraordinary individual, Thomas E. Bearden.*

Bearden's background raises a number of questions. It is stated he is a nuclear engineer, war games analyst, and military tactician, a Lieutenant Colonel (retired). He has over 26 years experience in air defense systems, tactics, and operations, technical intelligence, nuclear weapons employment, etc., etc. He has a Master of Science degree in Nuclear Engineering from *Georgia Institute of Technology* and a B.A. degree in Mathematics from Northeast Louisiana University. He belongs to many organizations including Mensa and holds a number of positions too numerous to mention. In addition, he is supposed to be a theorist and authority on a wide range of subjects including the paranormal, UFO, psychotronics, etc. These seem indeed to be impressive credentials, but in reality, have little meaning. As a matter of fact, they are more inclined to be stigmas instead of honors in view of the degree of confusion prevalent in these various fields. To list Bearden as a legitimate theorist on any esoteric subject is laughable, in view of what has been shown. Even being a member of Mensa does not add to his credibility. Isaac Asimov mentioned earlier was also a member. In view of the alleged scope of Bearden's activities, it seems



he is a prime example of that old maxim "A Jack of All Trades and a Master of None."

Bearden has authored a new book, *AIDS, Mankind's Great Threat* in which he continues the old harangue about Russia being by far the greatest menace to world peace, with a wide assortment of terrible weapons -- most of them based on Tesla's secrets. He would also have the public believe that the USSR has also rendered itself invulnerable to any counter measures. This is complete nonsense. It has become more than obvious the "power elite" have a stranglehold on the governments of both countries, and dictate their policies. This means neither country has "secret" weapons the other doesn't have. What Bearden has avoided pointing out is that our greatest and most dangerous enemy is in our own backyard. In fact, there is actually a greater suppression of realities in this country than elsewhere. This was proven when Daniel Ross had to go outside this country in order to obtain NASA photos which proved that Mars, Venus, and the Moon have livable environments.

Bearden is doing exactly what the "power elite" want: to create a "dangerous enemy" for more excuses for an arms build-up of exotic weapons and to divert public attention away from the real menace, also by propagating a pseudo-science from which nothing of any value can be spawned. This brings up an interesting question. Is Bearden an innocent pawn in this monstrous conspiracy, or is he in collusion with the "power elite"? In view of the fact that he has read the author's previous book and is an honored member of the military establishment, among other things, it would be somewhat naive to assume the former. The recent collapse of the Soviet Union and subsequent events bring into sharp focus the absurdity of Bearden's claims about Russia's amazing weapons.

## THE SEARL EFFECT AND RELATED UFO PHENOMENA

The Searl effect was discovered by an English electronic technician named John Searl in 1949. He noticed a small EMF or voltage was induced in rotating metal objects. The negative charge was on the outside, and the positive charge was around the center of rotation. He reasoned that free electrons were thrown outward by centrifugal force, leaving a positive charge in the central portion. It followed that an electrical generator might be built utilizing this principle.

He constructed his first generator in 1952, and tested it outdoors. Its performance and behavior far exceeded his expectations. The armature was rotated by a small engine. It produced a powerful electrostatic effect on nearby objects, accompanied by crackling sounds and the smell of ozone. Beyond a critical rotational speed, the armature continued to accelerate without the aid of the engine. The generator finally lifted off the ground, while still accelerating, and rose about 50 feet, breaking the connection between it and the engine. It remained at this height for a brief period, while still increasing its rotational velocity. At this time, a pink halo surrounded it, indicating ionization of the surrounding atmosphere at an extremely low pressure. It also caused local radio receivers to go on of their own accord. While still accelerating, it apparently reached another critical rotational velocity, at which stage it rapidly gained altitude and disappeared.

Since 1952, Searl and others have constructed numerous generators of varying sizes from 3 to 30 feet in diameter. Some of them have been lost in a similar manner. They claim to have developed a means of controlling them in the process.

Explanations for the phenomena are easily determined from the new concepts presented. When the armature rotated, soft particles impregnating the material were thrown outward leaving a low concentration around the center. Although Searl's reasoning was partially correct, he was wrong in assuming that free, hard electrons were affected by the centrifugal force. A similar effect is demonstrated by drag racers. It enables them to accelerate an average of about two G's, and as much as 6 G's at the beginning, over the quarter-mile course. The coefficient of friction between rubber and pavement is somewhat less than one, yet the performance of drag racers seems to

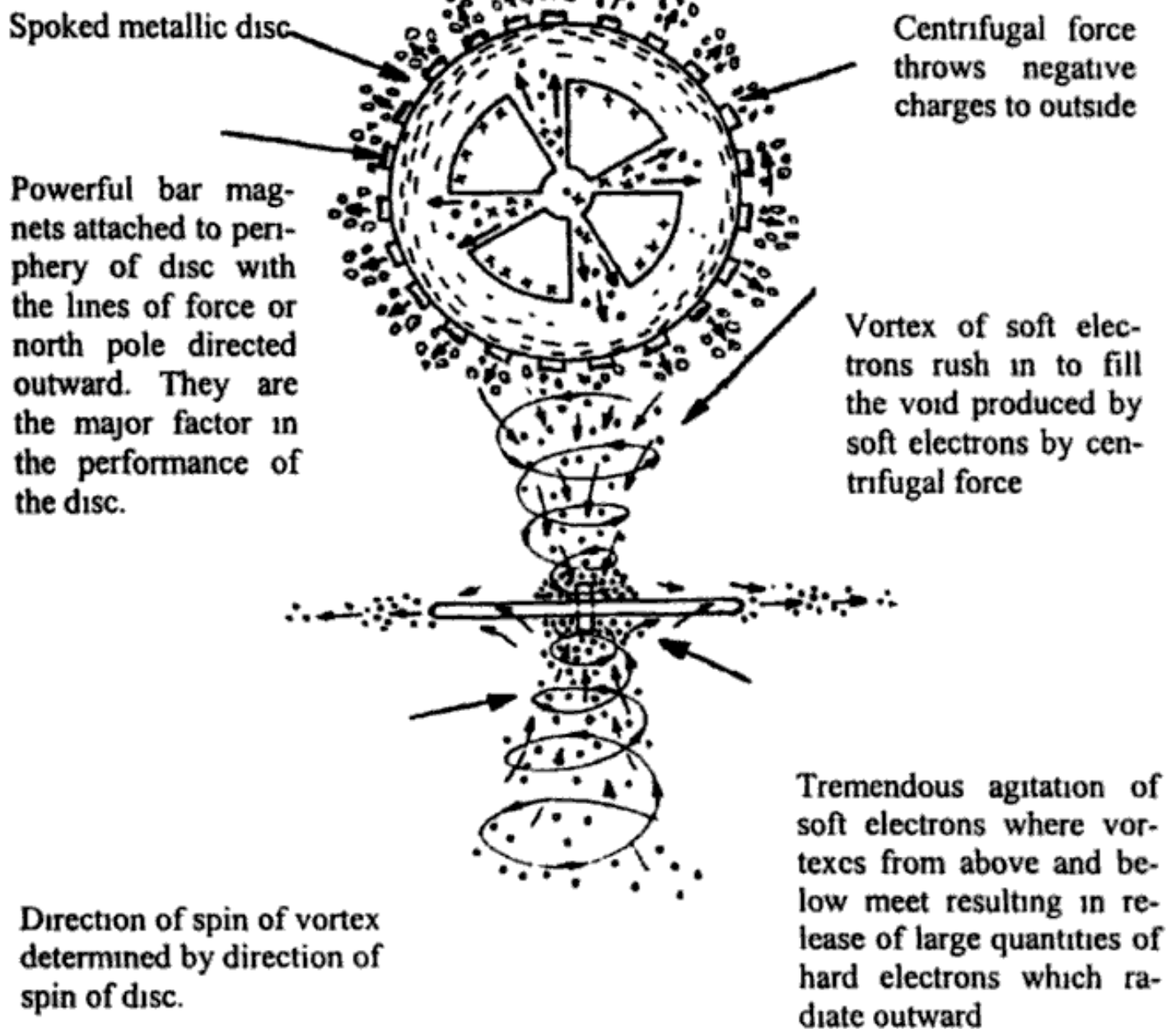

FIG. 33: THE PRINCIPLE OF THE SEARL GENERATOR

*Spokes enable torque to be exerted on disc by vortex of soft electrons which concentrate in spaces in between spokes. The rush to fill the void on one side of spoke due to spin produces unequal bombardments on opposite sides of spoke resulting in net force or torque in one direction. This force is enhanced by soft electrons disintegrating and releasing hard electrons which bombard spokes in on preferred direction. The magnets capture vast quantities of soft electrons which are thrown outward by centrifugal force. This creates the void for the rush of surrounding soft particles.*

indicate that this coefficient is much greater than two! Soft electrons are forced outward by the centrifugal force and readily penetrate the tire, producing a strong negative charge around the tire. This results in a bond between the tire and the road surface of sufficient strength to prevent slippage. It is interesting to note that there is considerable wheel spin before the dragster takes off. The wheels need to attain a sufficient rotational velocity before the bond between tire and road surface is enough to compensate for the power surge applied to the wheels.

The low concentration of soft electrons at the center of the Searl generator (see Fig. 33), due to the centrifugal force of the rotating armature produced a rush of soft electrons from surrounding areas toward the center. This was expedited by the metallic construction of the armature. The principle is similar to that involved in Reich's cloud-buster. Since the armature was not a solid disk, but consisted of spokes like a wheel, a vortex motion of soft electrons above and below it was generated. Ionized air molecules tended to be carried along with this motion of soft particles by electrostatic forces. The vortex motion was in the same direction as that of the armature. The abnormal activity of soft electrons permeating the armature released a high concentration of harder electrons throughout the material of the armature. This, in turn, lessened the inertial properties.

The combination of the reduced inertia and the torque induced by the vortex soon enabled the armature to turn without the aid of the engine. The overall charge of the armature became slightly negative because of the presence of the additional electrons released in the material. As a result, it was repelled upward by the Earth's gravitational field. The highest concentration of soft electrons is close to the ground. When the generator rose above this concentration, there was a temporary reduction or loss of its negative charge, causing it to stop rising temporarily. Since the rotational velocity was steadily increasing, the negative charge finally increased again to the extent that it continued its ascent.

The concentration of soft particles ejected laterally from the generator was so great that many disintegrated, thereby releasing enormous quantities of hard electrons. This drove most of the air molecules away from the periphery of the generator. This produced a heavily ionized section of rarified air. The pink halo around the generator was evidence of this. It was also noticed that the generator carried some of the ground with it as it rose. This was a result of the

powerful electrostatic forces produced in the generator by the hard electrons released from disintegrating soft electrons.

The automatic turning on of local radio receivers was caused by the flow of hard and soft electrons in all directions. Many of the soft particles were rendered partially unstable by collisions with air molecules and the soft particles. When they entered the circuits of radio receivers, they released hard electrons having a wide range of voltages. The concentration in the circuits was sufficient to produce the necessary amperage and voltage to operate the receivers.

Many researchers believe that the Biefeld-Brown Effect mentioned earlier is a major factor in the behavior of the Searl generator. From the analysis just presented, it is apparent that this is not the case. The Biefeld-Brown Effect has also been erroneously termed the electro-gravitational effect. This is a misnomer, since the Biefeld-Brown Effect is the result of the greater affinity electrons have for protons than do protons for electrons. This effect has no more relationship to gravity than does the rocket principle. However, it can be utilized as a highly sophisticated means of space propulsion in conjunction with the Searl generator. This might be superior to the method suggested earlier, using gravity-inducing radiations for space travel! When the inertial properties of a spaceship and its contents have been nullified by the Searl effect, only a slight force exerted on its exterior could give it unlimited acceleration. Condensers attached to the outside of a ship could be used to exert a force in any desired direction, utilizing the Biefeld-Brown Effect.

Interestingly enough, the phenomena associated with the Searl Effect are similar to those observed around many UFOs. It is more than likely that most UFOs employ this principle. According to information received by the author about 30 years ago, which supposedly came from the Air Force, UFOs have been clocked by Doppler Radar accelerating as much as 1500 G's. This might be difficult to achieve with gravity-inducing radiations alone. UFOs may also use crystals to generate the concentration of charges needed for the above-mentioned purposes. Perhaps they can be utilized even more effectively than the Searl Effect for this.

Several other well-known types of phenomena associated with UFOs need to be explained. UFOs have been known to freeze large ponds of water or ground over which they have been hovering. They have also accomplished the opposite, and burned or dehydrated areas



of ground and vegetation. An analysis of heat transfer and generation is mandatory in order to understand such phenomena.

The temperature of a body increases when it receives more soft particles than it is radiating. The temperature increase is the result of the soft particles which disintegrate inside the body and release the hard particles they contain. The sudden presence of hard particles and especially electrons which are not a part of the molecules, then agitate them. This generates an increase in temperature. Incidentally, it is the disintegrating soft particles releasing hard electrons that are responsible for thermionic emission.

If a body of moderate size receives no soft particles from outside sources, it will soon reach a state in which all of its molecules are in equilibrium with each other, and all relative motion ceases. This is a condition known as absolute zero or zero degrees Kelvin. Practically all the soft particles generated by the body pass through it, and are radiated outward without disintegrating. If a body is of sufficient size, most of the soft particles it generates disintegrate before they can reach the surface and a radiating body like the Sun or the larger planets is the result.

The reason for the burning and freezing effects of UFOs is now apparent. UFOs employing the Searl Effect can quickly draw all of the soft particles away from a given area or body, and a rapid drop in temperature occurs. The same principle is unwittingly applied by physicists and technicians in achieving extremely low temperatures. A magnetic field is employed. When the correct polarity is used, it draws soft particles away from the material being cooled. UFOs produce the burning effect by discharging great concentrations of soft particles at high velocities into a given area. It has also been noticed that UFOs passing over bodies of water cause water directly below them to move upward in a series of wavelets. The same principle was involved when Searl's generators carried chunks of ground with them as they moved upward.

The Searl effect is deeply involved with the behavior of everything that spins on an axis. Consider the spinning top or gyro. Conventional science has never come up with anything even remotely resembling an explanation concerning its behavior. Physicists try to create the illusion that they understand it and camouflage their ignorance with nebulous descriptions of its action accompanied by meaningless equations. A precessing gyro actually confutes the basic foundations

of conventional physics. For example, as it precesses, its center of mass extends well beyond its point of contact with the surface. It should tip over according to all the rules of academic physics. What force prevents it? Also the moment of inertia increases with the RPM, a property which is utilized for stabilizers. According to the "laws" of orthodox physics, the moment of inertia is a constant.

The explanation becomes almost self-evident in the light of principles already expounded upon. At a critical RPM, the outer rim becomes heavily charged negatively while the portion closer to the center of mass begins to take on a positive charge. The rim tends to be repelled upward by the Earth's gravity. The total effect is a counter-clockwise moment about the point of contact,  $O$ , which counter-balances the clockwise torque tending to tip it over.

The greater tendency for a rotating body to maintain its plane of rotation which produces a stabilizing effect is the result of the increase in the moment of inertia. The outer portion is given a total negative charge which is greater than that of its original positive when it was at rest. This means that the mass comprising the outer portion has a greater overall inertia than it had before. This portion of greatly increased inertia is also further removed from the center of mass than the rest of the body, which accentuates the moment of inertia and also the portion closer to the center of mass or rotation has a higher net positive charge than it had before. This means that its inertial properties have also increased, which also adds to the moment of inertia.

The precession of a gyro is another property in which explanations by "scientists" consist only of descriptions. The moment of the momentum of a precessing top about the point of contact,  $O$ , is the key. The moment of the portion of the disc further removed from  $O$  in a horizontal direction is in the direction of rotation. The moment of the portion on the opposite side of the disc is closer to  $O$  in a horizontal direction, and is also in the opposite direction to the other half of the disc. The result is a net torque about  $O$ , in the direction of spin. When the spinning gyro or top is vertical the moments of momentum on opposite sides about the point of contact balance out. Hence, there is no resultant force exerted on the mass in any preferred direction. However, when the axis of spin deviates from the vertical, the equilibrium is disturbed. Since momentum has the potential to produce a force, a resultant force in one direction causing a torque about,  $O$ , in the direction of spin is the result. This produces a wobble

or precession. It is, in principle, equivalent to taking the counter weights off a crankshaft or spinning an out-of-balance wheel.

As the RPM increases, the greater is the repelling force on the rim of the gyro. This results in a greater tendency of the gyro to assume a vertical position. The difference in the clockwise and counter-clockwise moment of momentum become less, and thus the rate of precession decreases.

The British scientist, Eric Laithwaite, demonstrated in 1974 the validity of what has just been presented. He had two electronically driven gyroscopes, each of which was placed on a hinged metal arm fixed to a central pivot. He made the gyroscopes rotate at high speeds and they rose in the air on the arms until they reached a curved rail that pushed them down again. The process was then repeated. When the gyros were motionless the entire assembly weighed 20 pounds. With the gyros spinning, the contraption weighted 15 pounds. The gyros rose on the hinged arm because of mutual electrostatic repulsion, produced by the strong negative charge caused by the Searl Effect. The strong, mutual repulsion would also impregnate the gyros to their center with negative charges. When they reached the curved rails they lost much of their rotational velocity and charges and consequently, dropped back to their original positions. Despite the fact that this demonstration was made at the *Royal Institute* at London in front of distinguished "scientists", it received little publicity because it was too damaging to accepted theories.

With a single gyro the situation is entirely different. As the gyro spins, negative charges are thrown out from the edge until a strong negative charge builds up and maintained along the periphery and a region close to the outer edge. At the same time most of the mass of the gyro is positively charged. The question which arises is "Does a gyro weigh more or less than it does when it is not spinning?" The author weighed a gyro before it was spun and while it was spinning. Repeated tests produced identical results. There was about a 10% increase in weight when the gyro was spinning. This is not surprising and is a confirmation of the principles elaborated upon. The percentage of increase is of course dependent on the shape or geometry of the gyro as well as the RPM.

The validity of this experiment is demonstrated by a little known fact. It is that a spinning gyro falls faster than it will when at rest. Having a higher overall positive charge when spinning than at rest, the Earth's gravity will give it a higher acceleration. It is to be

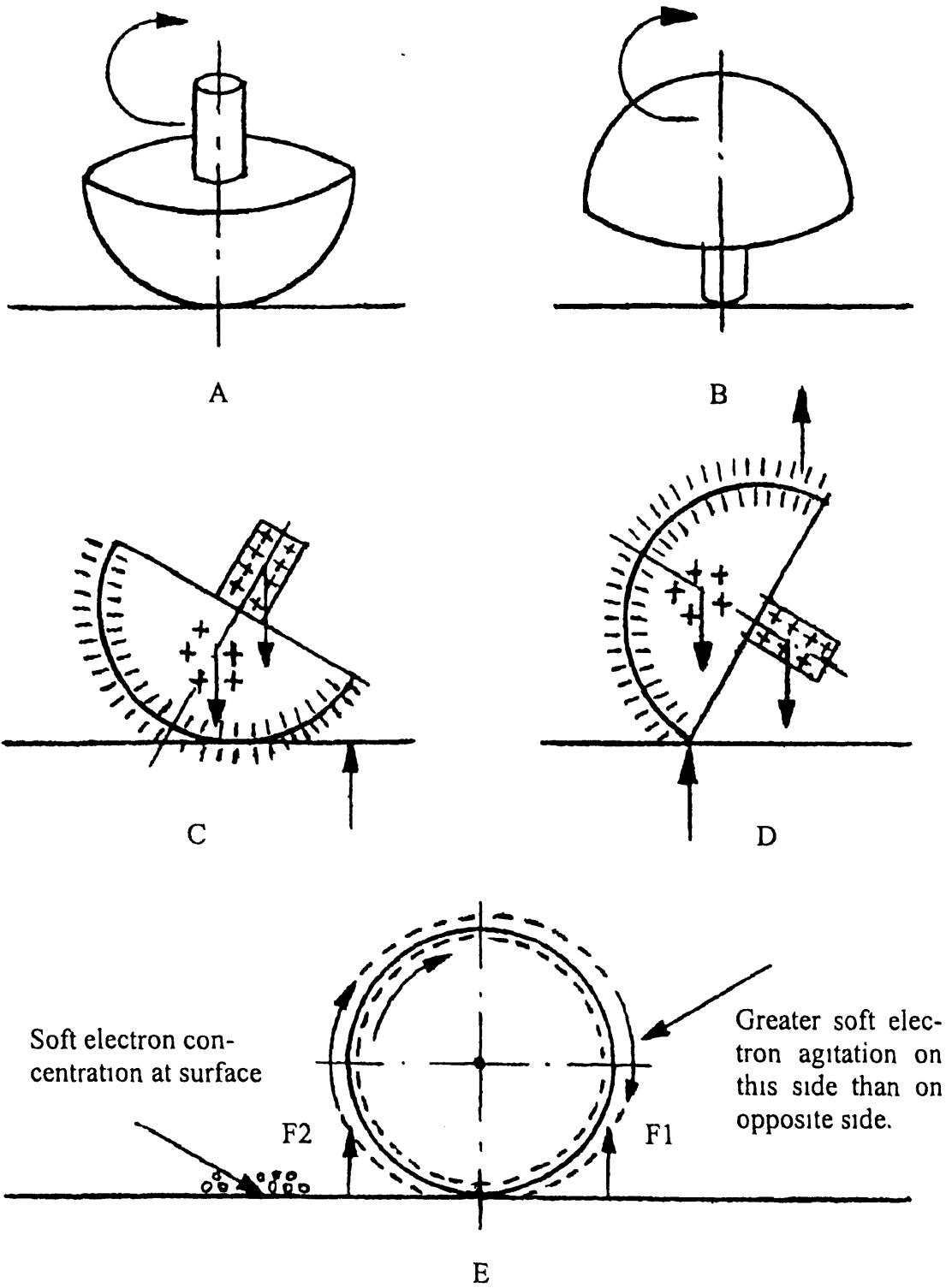

FIG 34: PRINCIPLE OF THE TRIPPS TOP

expected this particular property of a spinning gyro has been ignored by the scientific community. This is not because they were unaware of the phenomenon. Tesla and others used it to support some of their bizarre and illogical theories.

The principles elaborated upon in this chapter are demonstrated by an enigmatic toy known as the Tripps Top. Its behavior has completely baffled everyone, including the prominent physicists, although they are reluctant to admit it. They try to cover up their ignorance with an assortment of vacuous explanations, none of which are in agreement. This top consists of a mass attached to a stem as shown in the accompanying diagrams in Fig. 34. When it is with the hemisphere resting on the surface, it quickly flips over and starts with the stem as a base. More surprisingly, the direction of rotation of the top is now reversed. This means that from a top view the direction of rotation has changed. This violates all of the conventional rules of academic physics and the energy conservation law, since the center of mass in the second stage is higher than it was initially.

The following explanation may perhaps be the least odious of all the explanations offered by the physicists. Jearl Walker, in *Scientific American*, claims the simplest explanation ("simple minded" would be a more apt terminology) is that the flip over "arises from friction between the top and the surface on which it spins." That is, whenever the spin axis tilts away from the vertical, the top slides on part of its spherical surface. The friction creates a torque that precesses the top to an inversion.

This is in keeping with the standard explanation of why a spinning top precesses. "Precession results from the torque due to gravity." It has not been made clear how a given force can directly produce another force in a direction perpendicular to that of the original force. Such explanations as above are an affront to the intelligence of even a semi-rational person.

Diagrams C and D clearly show how the Searl Effect, in conjunction with gravity, produces the flip-over. The hemispherical base has a strong negative charge around its outermost periphery. The resultant levitation effect reduces the weight of the top. The centrifugal force around the stem is much weaker than that around the hemisphere. Consequently, there is little change in gravity effects in this region. This results in a net torque about the center of mass in the direction of the flip. This torque increases as the angle of tilt increases.



The change in direction of rotation remains to be explained. The reason is evident from diagram E, which shows an end view of the hemisphere in conjunction to the surface. The side moving toward the surface experiences a greater braking effect than the opposite side moving away from the surface. It is analogous to an object moving against the wind and one moving with the wind. There is always a concentration of soft electrons at a surface. The negative charges at the periphery will encounter greater repulsive forces at the side moving toward the surface than that moving away from it. There tends to be a greater compression of soft electrons on one side than on the opposite one. It should also be considered, that as the rotating slows down and stops, a residual negative charge remains around the outside long enough for it to be given an impetus in the opposite direction. A greater number of hard electrons have been released on the one side at the surface than on the opposite side because the soft electrons at the former location have experienced greater agitation. Thus  $F_1$ , in the diagram is greater than  $F_2$ . The effect is similar in principle to a compressed spring being released or a ball thrown against a wall bouncing back.

Another version of the Searl Effect can be produced by rotating magnets. If the stator of a generator or electric motor is rotated instead of the armature, it has been found that strong, magnetic effects are produced as much as 100 yards or more from the motor. The high concentration of soft electrons normally captured by the rotating magnets are propelled outward in abnormal concentrations by centrifugal force. This, coupled with the tendency of the magnets to capture additional soft electrons rushing in to fill the void, produces a still greater sink for the influx of soft particles from all directions. This is what happened with the air engine experiment described in the previous chapter. In this case, the concentration of soft electrons became so colossal, it produced the invisibility effect to be analyzed in Chapter 25.

It is evident that the rotating disc or magnets mentioned above can be utilized for a self-sustaining electric generator of almost unlimited capacity. The outer rim can be enclosed by conducting sheets to collect the electricity thrown outward by centrifugal force. It is then passed through a transformer for any desirable voltage. One terminal is hooked up to the axis while the other is connected to the collector. The current produced would be DC, which can be converted to pulsed DC, so that a transformer can be applied.

The above material indicates all of the details of Searl's disc were never revealed to the public. Many experiments with discs modeled after descriptions and photos of Searl's disc have failed to produce the results obtained by Searl. This indicates Searl perhaps used magnets placed at the rim of the discs.

An interesting phenomenon involving spinning wheels has been publically demonstrated with a bicycle with an extra frame combining two wheels in tandem free to rotate in either direction clockwise or counter-clockwise depending on the point of view. When they are set spinning in the same direction the stability of the bicycle is greatly enhanced. When they spin in opposite directions stability is lost. Of course this phenomenon was far from being adequately explained. The explanation becomes clear in the light of principles already elaborated upon. As already shown the inertia of a body is dependent on its ability to generate a magnetic field when in motion. The magnetic fields produced by spinning wheels are those produced by both soft and hard electrons in motion. The magnetic fields generated by moving soft electrons which cannot be detected with a magnetometer are far more extensive than those created by the hard electrons and also play a far more significant role in the moment of inertia of the spinning wheel. When the two wheels spin in opposite directions the magnetic fields tend to cancel and the inertial properties are lost. It should also be mentioned that the stability of the bike is enhanced only when the wheels spin in the same direction as the wheels in contact with the road.

## SUMMARY OF PART III

Part III developed new ideas introduced in Part I and Part II to a higher degree. It presented revolutionary concepts which will enable the more astute reader to comprehend some of the most baffling, borderland phenomena known to man, which will be presented in Part IV. Fundamental, weaknesses and limitations of present mathematical techniques were outlined. The nature of the ethers, light, soft particles, gravitation, electrostatic and magnetic fields, and the structure of the fundamental particles were explained and integrated by the unifying principle, for the first time in the entire history of this civilization.

These new insights made simple explanations possible for well-known anomalies which had never before been explained. These included the properties of helium at low temperatures, the Oregon vortex, certain gravitational paradoxes, and others. Some of the great research work of Wilhelm Reich was explained for the first time. It was shown that the Reich cloud-buster can be used to deactivate all modern weaponry yet hundreds of billions are extorted from the American public each year to support a multibillion dollar nuclear and armament industry and also a parasitic military organization for our alleged "protection". The effects of a cloud-buster are a wonderful confirmation of principles elaborated upon which show that soft electrons are vital to all the chemical and life processes. By drawing soft electrons away from a given region no chemical changes can take place in that area. The technology for the complete prevention of loss of life and property from fire and storm has been known for a long time but miscreants in positions of authority have managed to suppress it until now. Finally, a number of free energy devices were explained and descriptions given for practical inventions which can be built by the more enterprising researcher.