



carry
freedom

[Home](#). [Products](#). [Info](#). [Reviews](#). [Dealers](#). [Gallery](#). [About](#). [Blog](#). [Links](#)
[introduction](#)- [get plans](#)- [help](#)- [origins](#)- [links](#)

Bamboo bicycle Trailer

Bamboo bicycle trailer

Build a DIY bicycle trailer from these free plans.
There is no welding to be done, and no tube bending.
Make it any size, from any material, even bamboo.

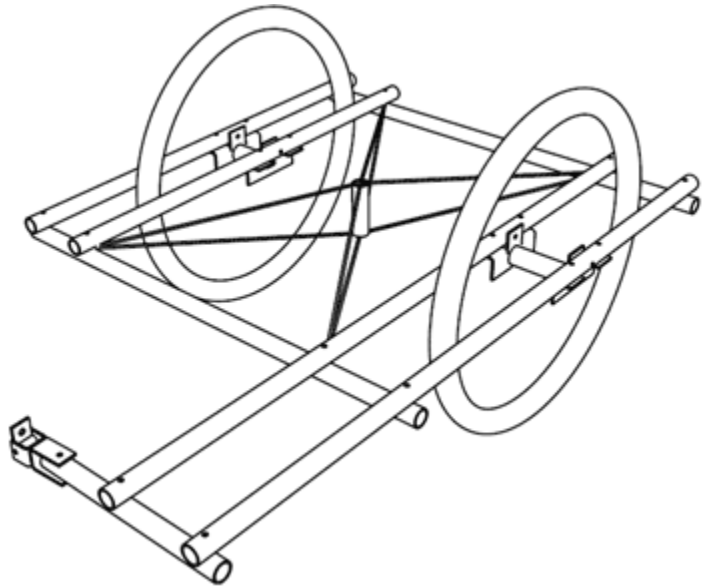

The problem - A bicycle trailer is a great way to carry things by bicycle, but many people simply cannot afford to buy a bicycle trailer like my [Y-Frame](#). It is often the people with the least money who would

benefit the most from a bicycle trailer.

A Solution - I designed the Bamboo Trailer to be easy to make from cheap materials, without too much skill or too many tools. Its easy to adapt the basic trailer to fit a wide range of cargo and materials.

Why - By making a trailer yourself you are taking control, what it can be is only limited by your imagination and enthusiasm. The value is not in the trailer itself, but in the knowledge of how to make a trailer. In a sense you will always have a bicycle trailer in your head if you ever need one. This knowledge makes you a richer person, and the world a richer place.

How - The first time you make a trailer will take 2-3 days as you gather materials, make mistakes, and learn. The next time you make one it will take about a day, and it will work much better.

But - Bamboo Trailers are generally less reliable, heavier and less efficient than a shop bought trailer, and if you put a price on your time they often work out more expensive.

Get Plans. [top](#)



To get the free plans email me, and tell me what you hope to use the trailer for.

Email bamboo@carryfreedom.com

Phone +44 1560 600 369

Skype n_lobnitz

If you complete the trailer please send me photos of it.

Telling me what you plan to use it for helps me build a picture of who is using the trailers

and for what. In itself this is nice to know, but it also helps me refine the plans to more accurately reflect who is using them. I post the photos up to a Flickr site, this library helps others greatly when it comes to building their trailer, as they can see how you did it and build on your ideas.

If I ever find the time I will start posting up on the internet your emails to me, to help share what the trailers are used for. If I ever get round to this I will be stripping out your email addresses and second names to preserve your privacy.

I can help. [top](#)



You can help this project along by sharing it with others, teaching people, and suggesting to me ways to improve the plans or the design. I am only one person, and most of my time is taken with earning a living manufacturing [beautiful bicycles](#) and [tough trailers](#), so any help you can give is greatly appreciated.

Origins [top](#)



The original idea for these plans came from Cass Gilbert, a Journalist with Cycling Plus.

Cass was in Nepal leading a guided cycling tour, he left his Y-Frame in a Village for a few months. It was endlessly used for carting rice and many other things between villages. But while the villagers loved the trailer they could not copy it or repair it locally.

This got me thinking about how it would be possible to make a cheap trailer for poor villagers. Poverty is many things, but fundamental to wealth is the freedom for people, goods and ideas to move. By making it easier for villagers to move things around their world becomes a richer, bigger place.

To simply parachute a finished trailer in does not help, it is a dead and alien object. Far better to spread an idea that will grow and adapt and take a life of its own. The plans could not make any assumptions about materials, tools, purpose, language skill or literacy. Especially important was to make sure it was easy and obvious to copy, normally an anathema for a designer. Ideally the basic form of the trailer should be dimensionless, so it can be built around the object it needs to carry. And lastly it would be good if the bicycle trailer did not strictly need a bicycle to be useful, as it is the Bamboo Trailer is good as a hand or donkey cart.

I find truth in the idea that simple objects are often the most difficult to design. For this I am proud of the Bamboo Trailer because it achieves so much with so little. Its factory can be anywhere, and its supply chain is simply the blowing of an idea on the wind.

Build something beautiful.

Nick

Other free bicycle trailer s [top](#)

You might also want to have a look at these other DIY trailers, there are plenty more out there but these are the ones I know about.

[Re-Cycle bicycle trailer](#) A bicycle trailer from welded angle iron, and bits of dead bike, including the sweet hitch.

[Econologia's Bike Frame Trailer](#) A trailer cunningly crafted from an old bicycle frame, among other things

[The IBike Trailer](#) Steel trailer plans from the International Bicycle Fund

[Bolted conduit trailer](#) Another clever trailer made from conduit.

[Aaron's \\$30 brazed conduit utility trailer](#) This is the man who got the bamboo bicycle trailer rolling



Carry Freedom gets their graphics done by done by [Do Good Advertising](#)